

462 SELECTORIZED LEG PRESS ASSEMBLY INSTRUCTIONS

20. LOOSELY attach one (1) 4-1/2 O.D. X 1 IN. BUSHING PULLEY between the FLATS at the BOTTOM of the MAIN FRAME, using one (1) 3/8 x 2-1/2 IN. BOLT, two (2) 3/8 IN. WASHER, one (1) 3/8 IN. LOCK WASHER, and one (1) 3/8 IN. NUTS. (SEE DETAIL C)
21. LOOSELY attach one (1) 4-1/2 O.D. X 1 IN. BUSHING PULLEY between the FLATS at the TOP of the MAIN FRAME, using one (1) 3/8 X 2-1/2 IN. BOLT, one (1) CABLE RETAINING CLIP, one (1) 3/8 IN. WASHER, one (1) 3/8 IN. LOCK WASHER, and one (1) 3/8 IN. NUT. (SEE DETAIL D)
22. AT THIS TIME TIGHTEN ALL LOOSE FRAME CONNECTIONS MADE TO THIS POINT.
23. Attach the WEIGHT STACK LABELS (15-205) to the WEIGHT STACK PLATES. (SEE DETAIL B)
24. Use the WEIGHT STACK PIN to adjust the desired number of WEIGHT PLATES on the WEIGHT STACK.
25. Attach the SEAT PAD to the SEAT PLATES on the PENDULUM FRAME, using two (2) 3/8 X 1-1/4 IN. BOLTS, two (2) 3/8 IN. LOCK WASHERS, and two (2) 3/8 IN. WASHERS.
26. Attach the SEAT BACK PAD to the BRACKET FLATS of the BACK REST TUBE on the PENDULUM FRAME, using two (2) 3/8 X 1-1/4 IN. BOLTS, two (2) 3/8 IN. LOCK WASHERS, and two (2) 3/8 IN. WASHERS. (SEE DETAIL E)
27. To install the CABLE ASSEMBLY, start by attaching the SWIVEL CONNECTOR of the CABLE to the TAB on the end of the SEAT ADJUSTMENT TUBE, using the CLEVIS PIN and the WIRE RING of the SWIVEL. (SEE DETAIL E)
28. Route the CABLE under and around the back side of the LOWER PULLEY, and up and around the back side of the UPPER PULLEY. (REMOVE PULLEYS FOR EASE OF INSTALLATION)
29. Pass the CABLE through the hole of the UPPER CROSS TUBE and down to the HEAD PLATE. Attach the CABLE to the HEAD PLATE ASSEMBLY by threading the STUD into the WEIGHT STACK SHAFT and tighten completely. (SEE CABLE ROUTING DIAGRAM) (DETAIL E)
30. TIGHTEN ALL LOOSE PULLEY CONNECTIONS MADE TO THIS POINT.
31. Slide two (2) 1-1/4 X 5 IN. GRIPS over the HANDLES of the PENDULUM FRAME. (NOTE: IF A LUBRICANT IS REQUIRED, RUBBING ALCOHOL THOROUGHLY COATING THE INSIDE OF THE GRIP IS THE BEST MATERIAL TO USE)
32. Attach the two (2) 2-1/2 X 9 IN. NON SKID STRIPS to one end of the GLUTE KICK TUBE. (WRAP EACH SKID STRIP AROUND OPPOSITE CORNERS AS SHOWN ON DRAWING) Also insert one (1) 1-3/4 IN. SQ. END CAP into the same end. Then insert the opposite end of the GLUTE KICK TUBE into the RECEIVING WELL on the BACK CORNER of the MAIN FRAME.

PARABODY INC.

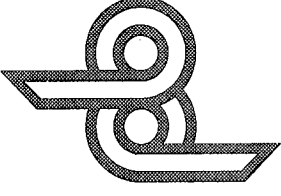

SELECTORIZED LEG PRESS

462

PRODUCT ASSEMBLY INSTRUCTION SHEETS

TOOLS REQUIRED FOR ASSEMBLY

- 3/4 INCH SOCKET
- 9/16 INCH SOCKET
- ADJUSTABLE WRENCH
- 5/32 ALLEN WRENCH
- HAMMER or RUBBER MALLET

REVISION: B

If you experience any problem with the assembly of this product, please contact your dealer or your PARABODY Customer Service Representative at:

1-800-328-9714

462 SELECTORIZED LEG PRESS ASSEMBLY PARTS LIST

SORT AND COUNT ALL PARTS BEFORE BEGINNING ASSEMBLY

HARDWARE:

ITEM	NAME/DESCRIPTION	QTY
1.	1/2 X 3-1/4 IN. BOLT	4
2.	3/8 X 2-1/2 IN. BOLT	2
3.	3/8 X 1-1/2 IN. BOLT	1
4.	3/8 X 1-1/4 IN. BOLT	5
5.	1/2 IN. WASHER	8
6.	3/8 IN. WASHER	8
7.	1/2 IN. LOCK WASHER	4
8.	3/8 IN. LOCK WASHER	8
9.	1/2 IN. NUT	4
10.	3/8 IN. NUT	3
11.	WEIGHT STACK PIN	1
12.	KNOB	1
13.	PLUNGER	1
14.	SPRING	1
15.	SPACER	1
16.	COTTER PIN	1
17.	5/16 IN. SET SCREW	2
18.	3/4 I.D. FLANGE BEARING	2
19.	CABLE RETAINING CLIP	1
20.	CLEVIS PIN	2
21.	2 IN. SQ. END CAP	6
22.	1-3/4 IN. SQ. END CAP	1
23.	RUBBER O-RING	2
24.	CAP PLUG	2
25.	WEIGHT PLATE BUSHING	40
26.	WEIGHT STACK CUSHION	3
27.	1-1/4 X 5 IN. GRIP	2
28.	4 X 17 IN. NON SKID STRIP	4
29.	2-1/2 X 9 IN. NON SKID STRIP	2
30.	LUBRICANT	1

NOTE: BOLT LENGTH IS MEASURED FROM THE UNDERSIDE OF THE HEAD OF THE BOLT.

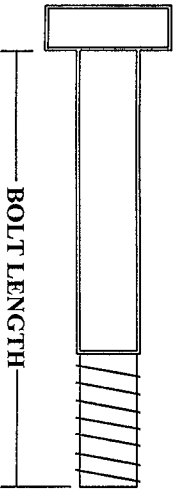

BOLT LENGTH RULER:

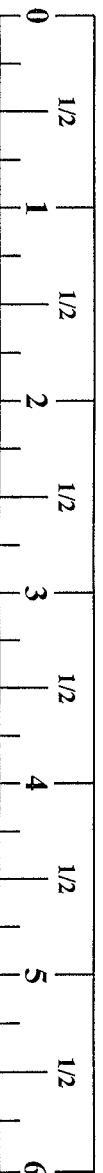

462 SELECTORIZED LEG PRESS ASSEMBLY INSTRUCTIONS

7. Insert one (1) 2 IN. SQ. END CAP into the end of BACK REST TUBE on the PENDULUM FRAME.
 8. Insert two (2) 3/4 I.D. FLANGE BEARINGS into each end of the PIVOT TUBE on the TOP of the PENDULUM FRAME. (THIS STEP MAY BE PRE-ASSEMBLED)
- STOP: BEFORE BEGINNING STEP 9, THE SEAT ADJUSTMENT TUBE MAY BE PRE-ASSEMBLED, IF SO REMOVE IT FROM THE FRONT END OF THE PENDULUM FRAME. TURN IT SO THAT THE TAB AT THE FRONT OF THE SEAT ADJUSTMENT TUBE IS FACING UP. RE-INSERT IT INTO THE FRONT END OF PENDULUM FRAME. SEE DETAIL E.**
9. Insert the SEAT ADJUSTMENT TUBE into the FRONT end of the PENDULUM FRAME. Pull back the SPRING PIN ASSEMBLY, and advance the SEAT ADJUSTMENT TUBE all the way in. (MAKE SURE TAB AT THE FRONT END OF THE SEAT ADJUSTMENT TUBE IS UP SEE DETAIL E)
 10. SECURELY fasten one (1) 3/8 X 1-1/4 IN. BOLT, one (1) 3/8 IN. LOCK WASHER, and one (1) 3/8 IN. NUT to the hole in the REAR of the SEAT ADJUSTMENT TUBE, on the UNDER SIDE of the PENDULUM FRAME between the SLOT. (SEE DRAWING) (SEE DETAIL G)
 11. Insert one (1) 2 IN. SQ. END CAP into the end of the PENDULUM FRAME below the BACK REST TUBE.
 12. Attach the PENDULUM FRAME to the MAIN FRAME, by sliding the PIVOT AXLE through the COLLARS on the PIVOT TABS of the MAIN FRAME, and through the PIVOT TUBE at the TOP of the PENDULUM FRAME. Thread two (2) SET SCREWS into both COLLARS and tighten. (SEE DRAWING) (THIS STEP MAY BE PRE-ASSEMBLED)
 13. Press two (2) WEIGHT PLATE BUSHINGS each, into the TOP of twenty (20) WEIGHT PLATES. (FORTY BUSHINGS TOTAL) (SEE DETAIL B)
 14. Place each of the two (2) WEIGHT STACK CUSHIONS (RADIUS EDGES FACING UP) over the guide rod holes on the MAIN FRAME. Insert each of the two (2) GUIDE RODS through the WEIGHT STACK CUSHIONS and into the MAIN FRAME. Apply a thin film of LUBRICANT to the GUIDE RODS.
 15. SECURELY assemble the WEIGHT STACK SHAFT to the HEAD WEIGHT PLATE, using one (1) 3/8 X 1-1/2 IN. BOLT, one (1) 3/8 IN. LOCK WASHER, and one (1) 3/8 IN. WASHER. (SEE DETAIL F)
 16. USING EXTREME CARE, slide each of the twenty (20) WEIGHT PLATES down over the GUIDE RODS and onto the MAIN FRAME. (NOTE: THE KEY HOLE OF THE WEIGHT PLATES SHOULD ALL BE FACING THE FRONT OF THE UNIT. SEE DRAWING)
 17. Slide the HEAD PLATE ASSEMBLY down over the GUIDE RODS onto the WEIGHT STACK. Also slip two (2) RUBBER O-RINGS over the ends of the GUIDE RODS.
 18. Press two (2) CAP PLUGS into the top of the two (2) GUIDE RODS.
 19. Insert two (2) CLEVIS PINS through the holes of the UPPER CROSS TUBE on the MAIN FRAME, and into the CAP PLUGS on the ends of the two (2) GUIDE RODS. Then slide the RUBBER O-RINGS up to the top of the GUIDE RODS.

462 SELECTORIZED LEG PRESS ASSEMBLY PARTS LIST

SORT AND COUNT ALL PARTS BEFORE BEGINNING ASSEMBLY

ITEM	NAME/DESCRIPTION	QTY
1.	MAIN FRAME(6305502)	1
2.	BASE(6304102)	1
3.	SEAT ADJUSTMENT TUBE(6304301)	1
4.	PENDULUM FRAME(6304702)	1
5.	PIVOT AXLE(6308101)	1
6.	GLUTE KICK TUBE(6308601)	1
7.	GUIDE ROD(6306401)	2
8.	WEIGHT STACK SHAFT(6284501)	1
9.	HEAD WEIGHT PLATE(6223001)	1
10.	WEIGHT PLATE(6214501)	20
11.	CABLE ASSEMBLY(6307401)	1
12.	WEIGHT STACK LABELS(6246801)	1
13.	SEAT PAD(6307801)	1
14.	SEAT BACK PAD(6308001)	1
15.	4-1/2 O.D. X 1 IN. BUSHING PULLEY(3116101)	2

WELDMENTS/PARTS:

462 SELECTORIZED LEG PRESS ASSEMBLY INSTRUCTIONS

IMPORTANT:

- THE PARABODY SELECTORIZED LEG PRESS MUST BE ASSEMBLED ON A FLAT LEVEL SURFACE TO ASSURE ITS PROPER FUNCTION.
- PARABODY, INC. STRONGLY RECOMMENDS THAT THIS PRODUCT BE ASSEMBLED BY TWO PERSONS TO AVOID POSSIBLE INJURY.

*** IMPORTANT ***

KEEP ALL LOOSE FRAME CONNECTIONS

LOOSE UNTIL INSTRUCTED IN THE ASSEMBLY STEP SEQUENCES TO SECURELY TIGHTEN

1. Insert two (2) 2 IN. SQ. END CAPS into the ENDS of the BASE SECTION.
2. LOOSELY assemble the MAIN FRAME to the BASE SECTION, using four (4) 1/2 X 3-1/4 IN. BOLTS, eight (8) 1/2 IN. WASHERS, four (4) 1/2 IN. LOCK WASHERS, and four (4) 1/2 IN. NUTS.
3. Insert two (2) 2 IN. SQ. END CAPS into the top of each ANGLED FOOT PLATE TUBE on both sides of the MAIN FRAME.
4. Attach four (4) 4 X 17 IN. NON SKID STRIPS to the ANGLED FOOT PLATE on the MAIN FRAME, as shown on drawing.
5. Slide one (1) WEIGHT STACK CUSHION over the PIN STOP at the BASE of the MAIN FRAME.
6. Assemble the SPRING PIN ASSEMBLY to the PENDULUM FRAME, using one (1) KNOB, one (1) PLUNGER, one (1) SPRING, one (1) SPACER, and one (1) COTTER PIN, using the following steps:
 - A. Assemble the KNOB to the PLUNGER.
 - B. Insert the PLUNGER through the first HOUSING and through the first hole of the second HOUSING.
 - C. Slip the SPRING and the SPACER over the end of the PLUNGER, (IN THAT ORDER)
 - D. Insert the PLUNGER through the second hole of the HOUSING.
 - E. Pull back the SPACER on the PLUNGER and insert the COTTER PIN through the hole. (SEE DETAIL A)
 - F.

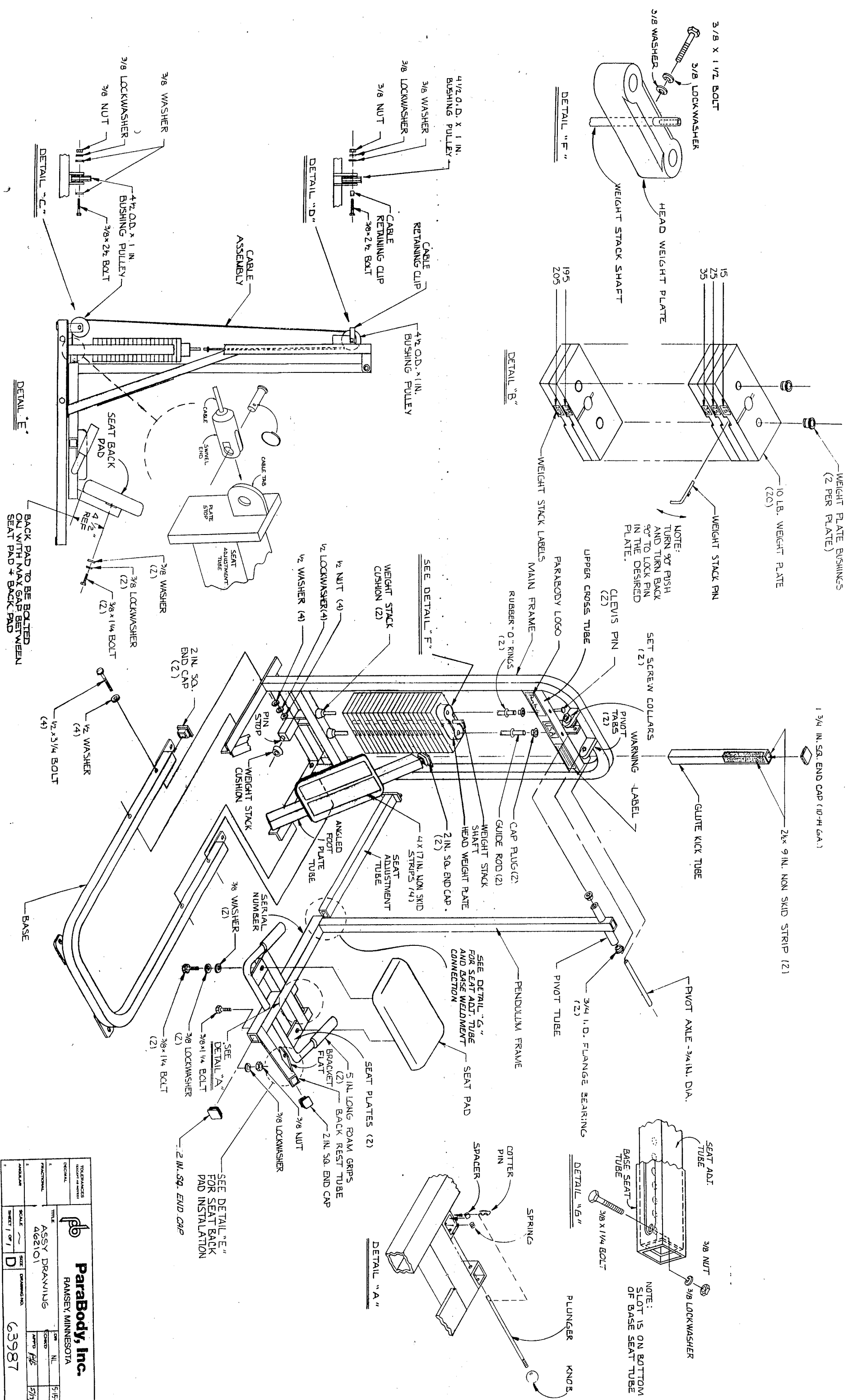

TOLERANCES UNLESS OTHERWISE SPECIFIED		FRACTIONAL		DECIMAL	
FRACTIONAL		DECIMAL		TITLE	
SCALE		DATE		DRAWING NO.	
SHEET 1 OF 1		D		63987	
ParBody, Inc.		RAMSEY, MINNESOTA		DATE	
5-15-72		5/17/72		APP'D	
462101		462101		CHK'D	

Free Manuals Download Website

<http://myh66.com>

<http://usermanuals.us>

<http://www.somanuals.com>

<http://www.4manuals.cc>

<http://www.manual-lib.com>

<http://www.404manual.com>

<http://www.luxmanual.com>

<http://aubethermostatmanual.com>

Golf course search by state

<http://golfingnear.com>

Email search by domain

<http://emailbydomain.com>

Auto manuals search

<http://auto.somanuals.com>

TV manuals search

<http://tv.somanuals.com>