

PARABODY

Serious Steel

**843101
POWER RACK
ASSEMBLY INSTRUCTIONS**

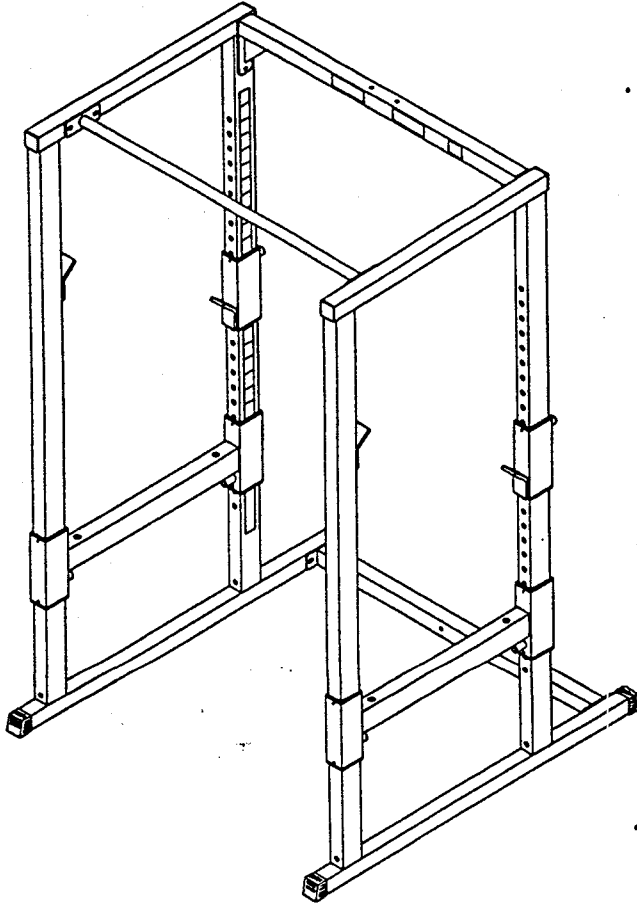

**ParaBody, Incorporated
14150 Sunfish Lake Boulevard
Ramsey, MN 55303
1-800-328-9714**

Part # 6612301

1

Revision: 06/25/96

843101 POWER RACK ASSEMBLY PARTS LIST

SORT AND COUNT ALL PARTS BEFORE BEGINNING ASSEMBLY

HARDWARE:

ITEM	NAME/DESCRIPTION	QTY
1.	1/2 X 4 IN BOLT	4
2.	1/2 X 3 IN BOLT	12
3.	1/2 IN WASHER	20
4.	1/2 IN LOCK NUT	14
5.	SPRING PIN ASSEMBLY	6
6.	2 IN SQ END CAP	4
7.	2 IN SQ COVER CAP	4
8.	3 X 2 IN INSERT GUIDE	12

WELDMENTS/PARTS:

ITEM	NAME/DESCRIPTION	QTY
1.	UPRIGHT WELDMENT(6641503)	2
2.	UPRIGHT BASE WELDMENT(6641802)	2
3.	SAFETY RAIL WELDMENT(6605702)	2
4.	BAR SUPPORT WELDMENT(6605802)	2
5.	CHIN BAR WELDMENT(6605902)	1
6.	LOWER CONNECTOR WELDMENT(6606002)	1
7.	UPPER CONNECTOR WELDMENT(6606102)	1

NOTE: BOLT LENGTH IS MEASURED FROM THE UNDERSIDE OF THE HEAD OF THE BOLT.

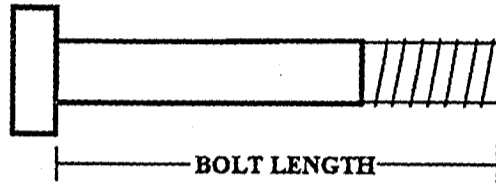

BOLT LENGTH RULER:

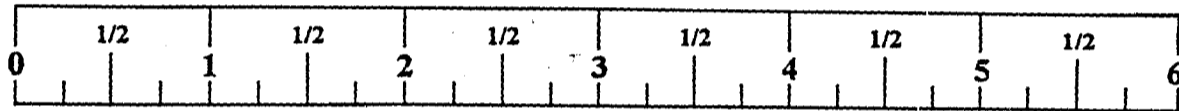

843101 POWER RACK ASSEMBLY INSTRUCTIONS

THANK YOU

FOR PURCHASING THE **843101 POWER RACK**. PLEASE SAVE THESE ASSEMBLY INSTRUCTIONS FOR YOUR PERSONAL REFERENCE, AND ADDITIONAL SERVICE INFORMATION.

*****IMPORTANT*****

- **THE 843101 POWER RACK MUST BE ASSEMBLED ON A FLAT, LEVEL SURFACE TO ASSURE ITS PROPER FUNCTION.**
- **PARABODY STRONGLY RECOMMENDS THAT THIS PRODUCT BE ASSEMBLED BY TWO PEOPLE TO AVOID POSSIBLE INJURY.**
- **IF YOU EXPERIENCE ANY PROBLEM WITH THE ASSEMBLY OF THIS PRODUCT, PLEASE CONTACT YOUR DEALER OR YOUR PARABODY CUSTOMER SERVICE REPRESENTATIVE AT: 1-800-328-9714**
- **TOOLS REQUIRED: RATCHET, 3/4 SOCKET and WRENCH, and RUBBER MALLET or HAMMER**

1. Slide four (4) 2 IN SQ COVER CAPS over the ends of each UPRIGHT BASE WELDMENT as shown on drawing.
2. **LOOSELY** assemble the LOWER CONNECTOR WELDMENT between each UPRIGHT BASE WELDMENT as shown on drawing.
3. Insert twelve (12) 3 X 2 IN INSERT GUIDES into the ends of each SAFETY RAIL WELDMENT and each BAR SUPPORT WELDMENT as shown in (DETAIL A). **NOTE: MAKE SURE THE INSERT GUIDES SNAP INTO THE HOLES OF THE WELDMENTS.**
4. **SECURELY** assemble the six (6) SPRING PIN ASSEMBLIES to the SPRING PIN BARRELS on each SAFETY RAIL WELDMENT and each BAR SUPPORT WELDMENT as shown in (DETAIL A).
5. Slide one (1) BAR SUPPORT WELDMENT and one (1) SAFETY RAIL WELDMENT (IN THAT ORDER) onto each UPRIGHT WELDMENT as shown on drawing.
6. Insert four (4) 2 IN SQ END CAPS into the ends of the UPRIGHT WELDMENT as shown on drawing.
7. **LOOSELY** assemble each UPRIGHT WELDMENT to the UPRIGHT BASE WELDMENTS as shown on drawing.
8. **LOOSELY** assemble the UPPER CONNECTOR WELDMENT and the CHIN BAR WELDMENT between the UPRIGHT WELDMENTS as shown on drawing.
9. When all components are assembled, **SECURELY** tighten all bolt connections.

DASH NO	DESCRIPTION
01	AS SHOWN

2 IN SQ END CAP (4)

LABEL, RISK/USA

CHAIN BAR WELDMENT

SEE DETAIL A

SAFETY RAIL WELDMENT (2)

SEE DETAIL A

LOWER CONNECTOR WELDMENT

1/2 IN LOCK NUT (4)

3 X 2 IN INSERT GUIDE (2)

SPRING PIN ASSEMBLY

SPRING PIN BARREL
SAFETY RAIL WELDMENT
BAR SUPPORT WELDMENT

DETAIL A

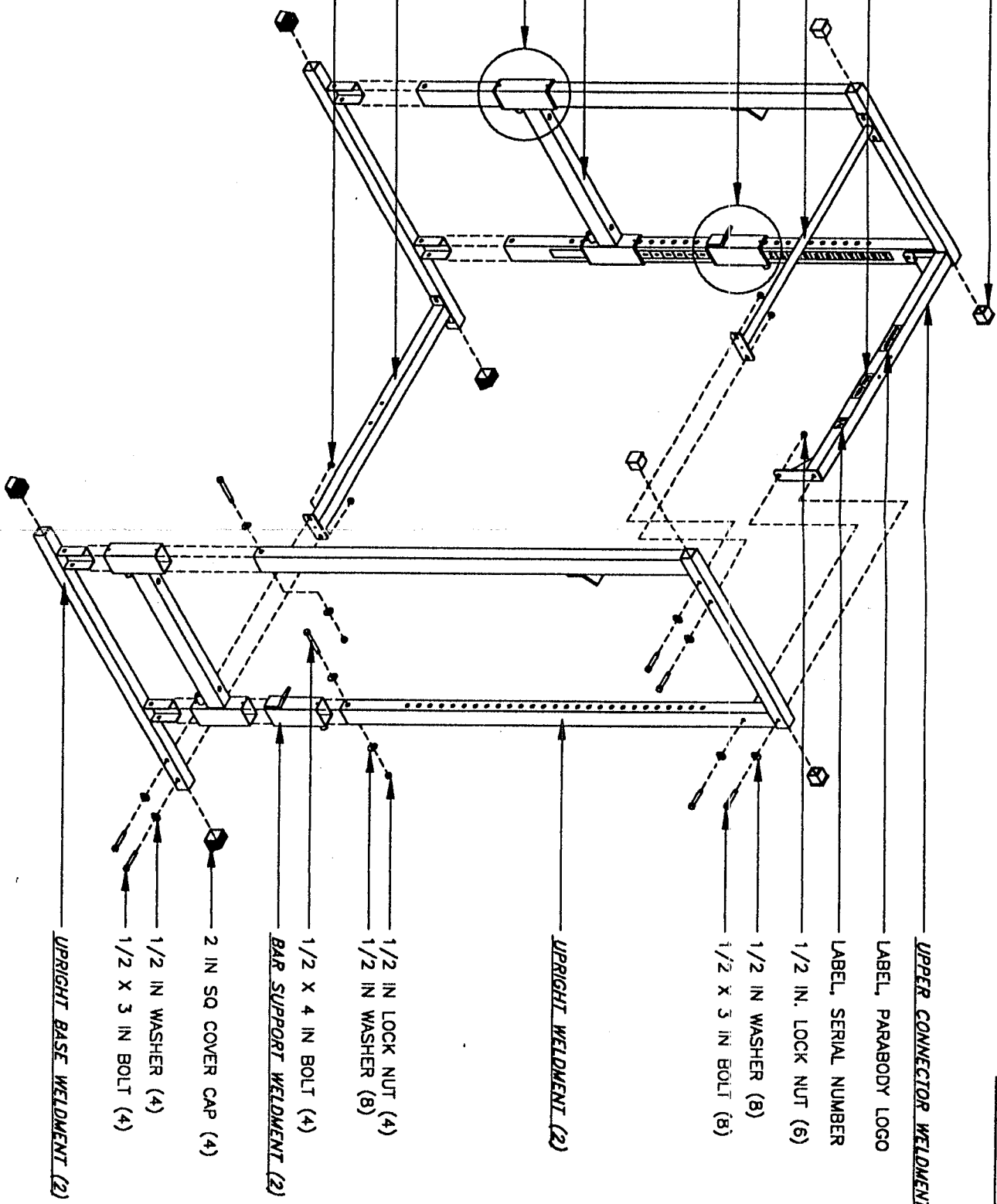

REVISIONS

REV	DESCRIPTION	CHG NO	APP'D	DATE
A	REMOVE DETAIL B	2775	MGN	6/96
B	LOWER HOLE LOCATION	2775	MGN	6/96

TOLERANCES
(EXCEPT AS NOTED)
DECIMAL

~

FRACTIONAL

~

ANGULAR

~

PARABODY, INC.
RAMSEY, MINNESOTA

TITLE
ASSY INST, 843101

SCALE 1/24 SIZE B DRAWING NO. 66123
SHEET 1 OF 1

DR	MGN	4/96	CHK'D	MGN	4/96	APP'D	MGN	4/96
----	-----	------	-------	-----	------	-------	-----	------

Free Manuals Download Website

<http://myh66.com>

<http://usermanuals.us>

<http://www.somanuals.com>

<http://www.4manuals.cc>

<http://www.manual-lib.com>

<http://www.404manual.com>

<http://www.luxmanual.com>

<http://aubethermostatmanual.com>

Golf course search by state

<http://golfingnear.com>

Email search by domain

<http://emailbydomain.com>

Auto manuals search

<http://auto.somanuals.com>

TV manuals search

<http://tv.somanuals.com>