

PARABODY

Serious Steel

950 ST 950102 ASSEMBLY INSTRUCTIONS

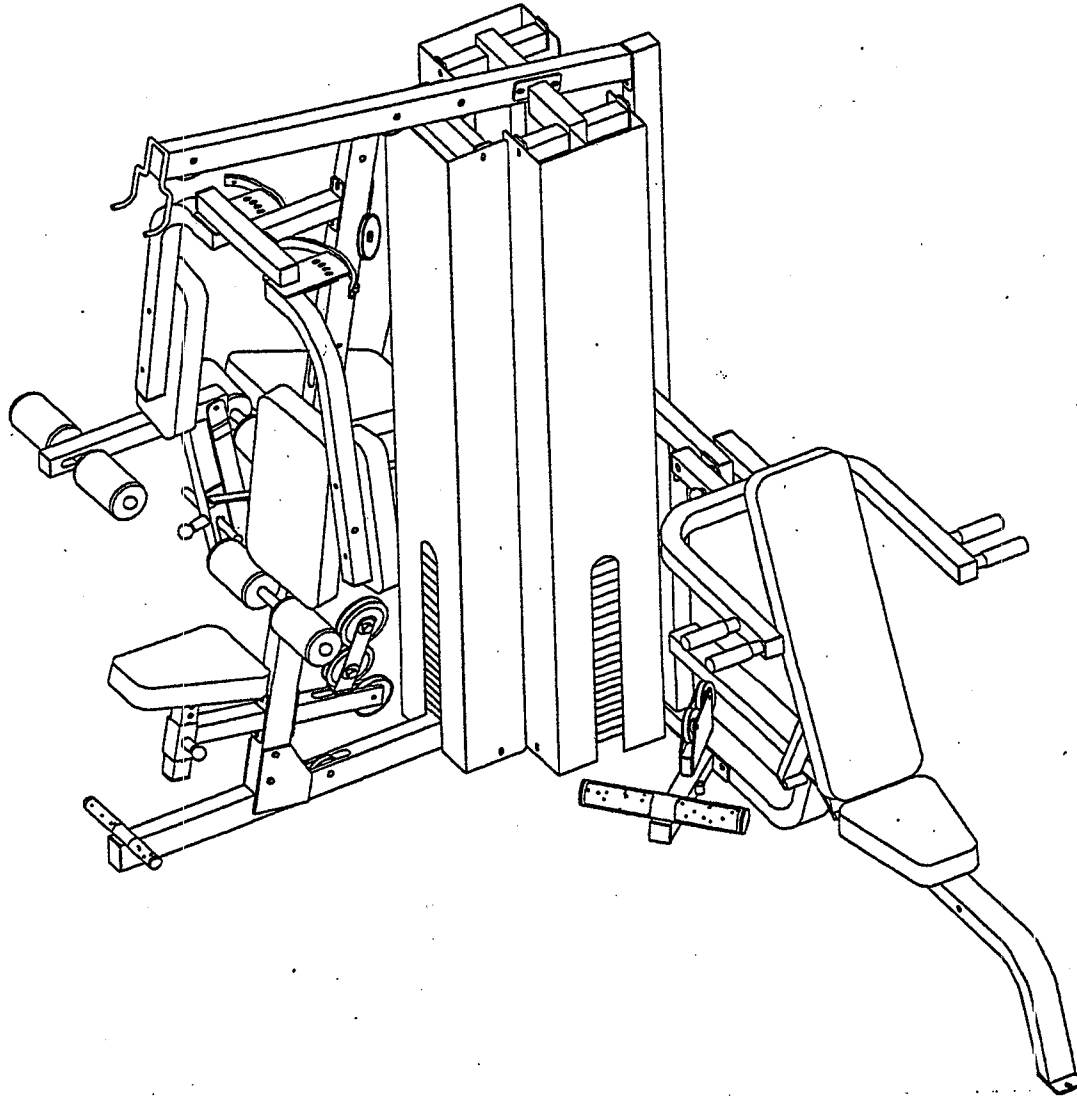

NO PLASTIC STHANDS. — ONLY WITH METAL LEFT FOR 8500.
SO ONLY 8500 FITTED.

Part # 6705001

1

Revision: 08/04/97

!!! ATTENTION !!!

UNLESS OTHERWISE SHOWN, ALL CONNECTIONS WILL CONSIST OF ONE (1) BOLT, TWO (2) WASHERS, AND ONE (1) LOCK NUT.

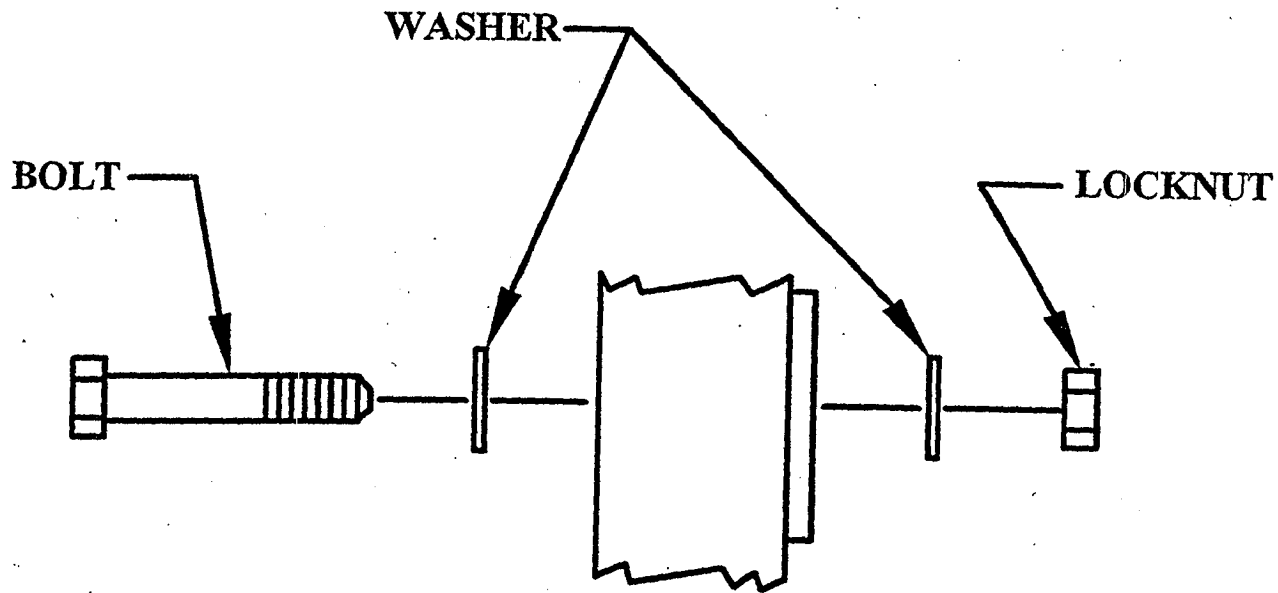

NOTE: BOLT LENGTH IS MEASURED FROM THE UNDERSIDE OF THE HEAD OF THE BOLT.

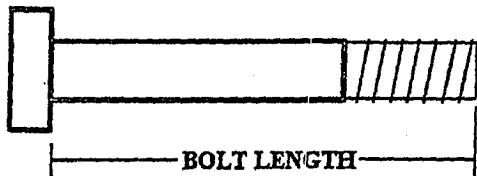

BOLT LENGTH RULER:

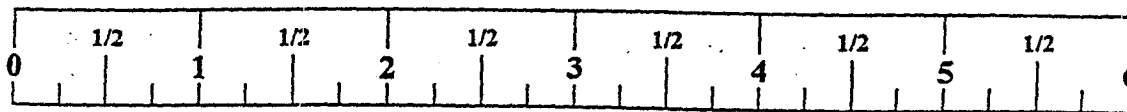

950 ST Parts List

KEY	PART #	DESCRIPTION	QTY	KEY	PART #	DESCRIPTION	QTY
1	6623603	PRESS WT STACK BASE WHT	1	62	6412001	ASSY SPRING PIN 3/8 DIA	6
2	6624202	BACK PAD ANGLE LEFT BLK	1	63	6416601	GLIDE 1-1/2 X 3/4 UHMWPE QTY8	2
3	6624302	BACK PAD ANGLE RIGHT BLK	1	64	6466901	ASSY SPRING PIN 1/2 DIA	2
4	6622903	PEC ARM RIGHT WHT	1	65	3103801	LINK SNAP 5/16 DIA	4
5	6623003	PEC ARM LEFT WHT	1	66	3104901	BEARING FLG 3/4 ID X 1 OD	6
6	6623503	PRESS ARM WHT	1	67	6214501	WEIGHT PLATE	60
7	6624502	CALF/LOW ROW BLK	1	68	3109602	NUT PAL 1/2 ID	1
8	6624603	LEG CURL/EXT WHT	1	69	6020601	BEARING FLG 1/2 ID X 5/8 OD	4
9	6625203	LEG CURL HANDLE WHT	1	70	6075906	CHAIN 12 LINK	1
10	6625303	REAR LEG BASE WHT	1	71	6166701	BRKT L 2-7/8 X 1 X 1	2
11	6625402	LEG BACK PAD ADJ BLK	1	72	6214401	PIN WEIGHT STACK SELECTOR	3
12	6625502	LEG BACK PAD SUPTBLK	1	73	6406401	HINGE TAB 3/16 X 1-1/4 X 6	4
13	6692903	PRESS BASE WHT	1	74	6480301	SPACER FLANGE 3/8 ID X 5/8 OD	28
14	6692003	LEG FRAME WHT	1	75	6533501	BRKT L 2-3/8 X 1 X 1	3
15	6617903	BASE WHT	1	76	6618901	AXLE 3/4 DIA X 2-9/32	1
16	6621001	LAT BAR CHROME	1	77	6619501	BEARING SLV 3/4 ID X 1-1/8 OD	2
17	6623903	PRESS FRAME WHT	1	78	3102501	WASHER FLAT 3/8 ID	69
18	6704903	LEG WEIGHT STACK BASE WHT	1	79	3102502	WASHER FLAT 1/2 ID	49
19	6705501	ROLLER PAD PU 3/4ID X 4OD X 7	8	82	3102801	NUT NYLOCK 1/2-13	22
20	6616703	TOP BOOM WHT	1	83	3102802	NUT NYLOCK 3/8-16	39
21	6617103	REAR UPRIGHT WHT	1	84	3102804	NUT NYLOCK 1/2-13 LOW HT	8
22	6622503	BEARING HOUSING WHT	1	85	3202101	BOLT, 1/2-13 X 1-1/4	2
23	6623402	PRESS ARM ADJUST BLK	1	86	3114502	WASHER LOCK 3/8 ID BZ	5
24	6621503	PRESS GUIDE ROD SUPPORT WHT	1	87	3102910	BOLT, 1/2-13 X 3	3
25	6621603	LEG GUIDE ROD SUPPORT WHT	1	88	3102917	BOLT, 1/2-13 X 4	4
26	6686802	PULLEY BRACKET	1	89	3102918	BOLT, 1/2-13 X 3-1/4	6
27	6704501	ROLLER PAD SHAFT, 16-3/4 IN.	3	90	3102937	BOLT, 1/2-13 X 4-1/2	4
28	6523401	GUIDE ROD	6	91	3102943	BOLT, 1/2-13 X 3-1/2	6
29	6529702	PEC CAM BLK	2	92	3102949	BOLT, 1/2-13 X 5-1/2	1
30	6594702	FLOATING PULLEY BLK	1	93	3102954	BOLT, 1/2-13 X 7-1/2	1
31	6617303	FRONT UPRIGHT WHT	1	94	3102925	BOLT, 1/2-13 X 6-1/2	1
32	6620903	FLOATING PULLEY STOP WHT	1	95	3102904	BOLT, 3/8-16 X 3	5
33	6691803	SEAT SUPPORT WHT	1	96	3102905	BOLT, 3/8-16 X 3-3/4	2
34	6624903	ROLLER PAD ADJUSTER WHT	2	97	3102909	BOLT, 3/8-16 X 1	14
35	6662203	LEG EXT HANDLE RHT WHT	1	98	3102915	BOLT, 3/8-16 X 3-1/4	8
36	6625903	CENTER PULLEY BRKT WHT	1	99	3102922	BOLT, 3/8-16 X 2-3/4	23
37	6628302	PLATE 1/8 X 2 X 8 BLK	1	100	3102933	BOLT, 3/8-16 X 2	9
38	6692402	PAD SUPPORT BLK	1	101	6375801	STRAP AB CRUNCH	1
39	6623702	WOLFF SLEEVE BLK	1	102	6382301	ASSY PLATE BUSHING 10 CT	12
40	6662303	LEG EXT HANDLE LFT WHT	1	103	6409101	STRAP ANKLE STANDARD	1
41	6624402	SWIVEL PULLEY BRKT BLK	1	104	6535601	CABLE ASSY BE-BE 77-5/8	1
42	6704601	ROLLER PAD SHAFT, 19-1/4 IN.	1	105	6627401	CABLE ASSY WS-NB SE 221-1/4	1
43	6621203	PEC GUIDE ROD SUPPORT WHT	1	106	6707801	CABLE ASSY WS-NB,SE 60-3/4	1
44	66371XX	PAD ASSEMBLY, 22 X 10-1/2	1	107	6627601	CABLE ASSY WS-NB SE 273-1/2	1
45	66186XX	PAD ASSEMBLY, 13-1/2 X 10-1/2 T	1	108	6704701	CABLE ASSY WS-L 171	1
46	66377XX	PAD ASSEMBLY, 16 X 6	2	109	3108002	CUSHION WEIGHT STACK 3/4 ID	6
47	66370XX	PAD ASSEMBLY, 15-3/4 X 15-1/2 T	1	110	3116101	PULLEY 4-1/2 OD X 3/8 ID X 1	6
48	66373XX	PAD ASSEMBLY, 22 X 10-1/2	1	111	3116201	PULLEY 3-1/2 OD X 3/8 ID X 1	18
49	66353XX	PAD ASSEMBLY, 13-1/2 X 10-1/2 T	1	112	3202301	BEARING PILLOW BLOCK 1 ID	2
50	66363XX	PAD ASSEMBLY, 33-1/2 X 10-1/2	1	113	6284501	SHAFT SELECT 3/4 DIA 20 HOLE	3
51	6533301	SHROUD ASSY 950 PEC STATION	1	114	6389701	BAR LOW ROW CHROME	1
52	6636101	SHROUD ASSY 950 LEG STATION	1	115	6619301	PIN U 1/2 DIA X 6-1/8 X 3-7/8	1
53	6636201	SHROUD ASSY 950 PRESS STATION	1	116	6651602	PLATE, 1/2 X 2 X 15-1/2"	2
54	3105401	STARLOCK 3/4	8	117	6714601	PTD ASSY, HEAD PLATE BLK	3
55	3108901	WASHER PLASTIC 2 OD X .755 ID	14	118	6189501	WEIGHT STACK LABELS	3
56	3116001	BUMPER RUBBER 1-1/4 SQ	2	119	3102902	BOLT, 3/8-16 X 2-1/4	1
57	3117401	CAP PLUG #6X	6	120	6122704	SPACER, 3/8 ID X 5/8 OD X 1/4	1
58	3118401	CAP VINYL 7/16 ID X 4	1	121	6705001	950 ST ASSEMBLY INSTRUCTIONS	1
59	3202401	CAP SCREW BTN HEAD 3/8-16 X 1	13	122	3102901	BOLT, 3/8-16 X 1-1/4	3
60	6140701	GLIDE 1 X 1	4				
61	6177001	STRIP NON-SKID 2-1/2 X 5-1/2	4				

Frame Assembly Instructions

Use this procedure to assemble the frame of the ParaBody 950ST

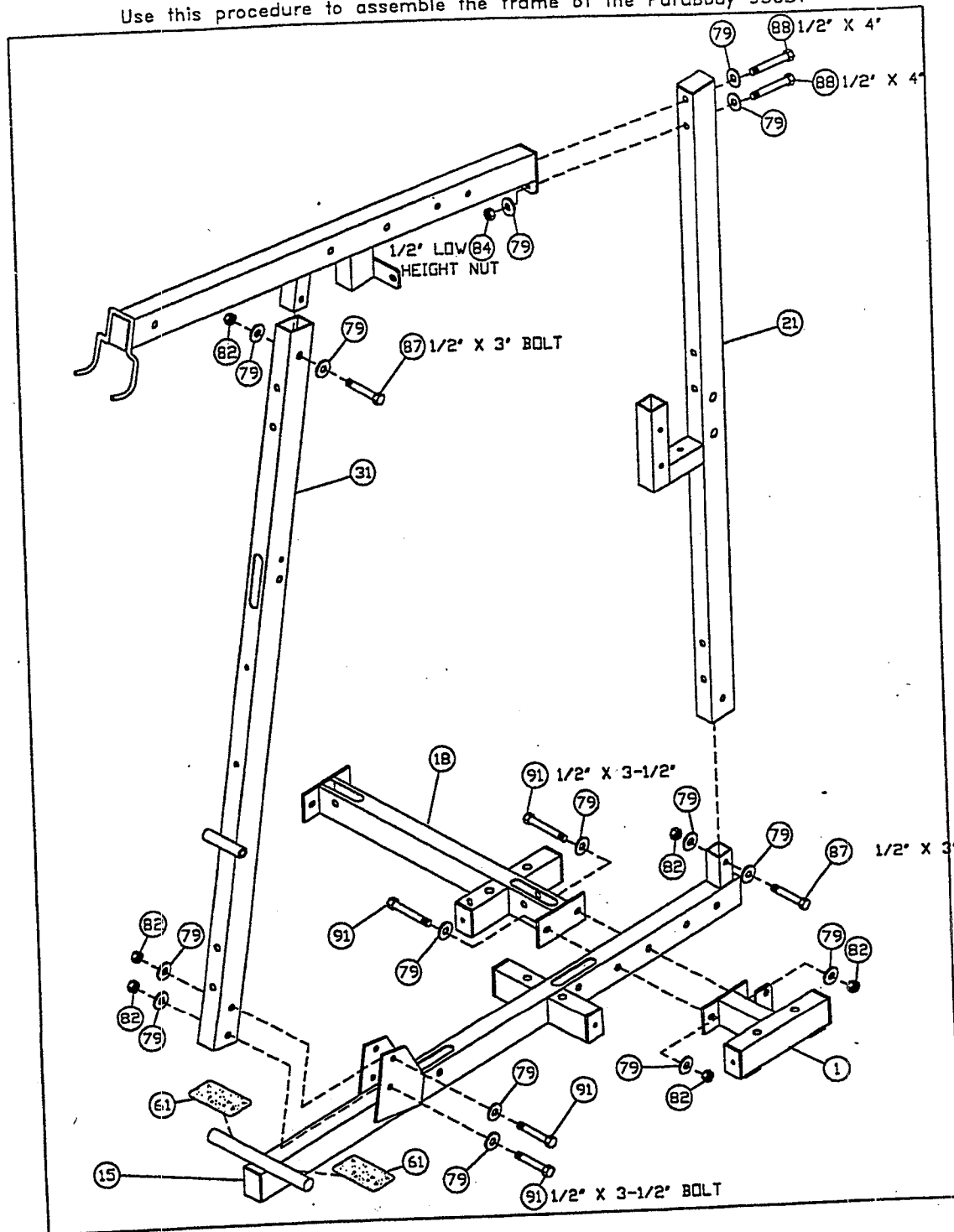

Step 1

- A. Loosely assemble the leg weight base (18) and the press weight stack base (1) to the base (15) using two 1/2 x 3-1/2" bolts (91), four 1/2" washers (79), and two 1/2" nylock nuts (82) as shown. Apply two non-skid strips (61) to the base as shown.
- B. Loosely assemble the front upright (31) to the base (15) using two 1/2 x 3-1/2" bolts (91), four 1/2" washers (79), and two 1/2" nylock nuts (82) as shown.
- C. Loosely assemble the rear upright to the base (15) using one 1/2 x 3" bolt (87), two 1/2" washers (79), and one 1/2" nylock nut (82) as shown.
- D. Loosely assemble the top boom (20) to the front upright (31) using one 1/2 x 3" bolt (87), two 1/2" washers (79), and one 1/2" nylock nut (82), and to the rear upright (21) using two 1/2 x 4" bolts (88), three 1/2" washers (79), and one 1/2" low height nylock nut (84) as shown. Tighten all frame connections.

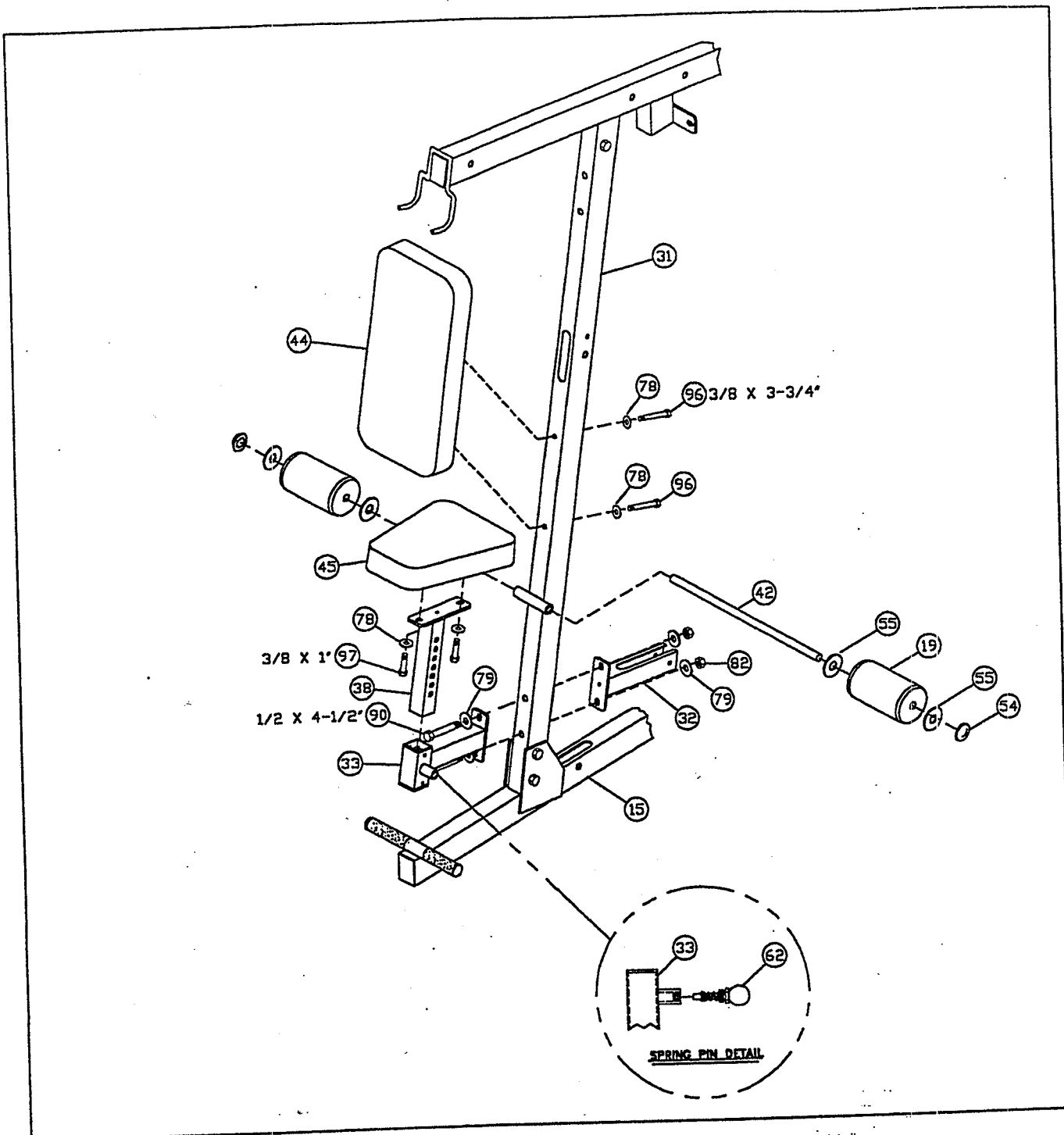

Step 2

- A. Securely assemble the floating pulley stop (32) and the seat support (33) to the front upright (31) using two 1/2 x 4-1/2" bolts (90), four 1/2" washers (79), and two 1/2" nylock nuts (82).
- B. Securely assemble one 3/8" spring pin (62) to the seat support (33) as shown.
- C. Securely attach one seat pad (45) to the pad support (38) using two 3/8 x 1" bolts (97), and two 3/8" washers (78) as shown.
- D. Carefully insert the pad support (38) into the seat support (33) and engage spring pin into one of the holes.
- E. Securely attach one back pad (44) to the front upright (31) using two 3/8 x 3-3/4" bolts (96), and two 3/8" washers (78).
- F. Attach two roller pads (19) to the front upright (31) using one 19-1/4" roller pad shaft (42), four plastic washers (55) and two 3/4" starlock collars (54) as shown.

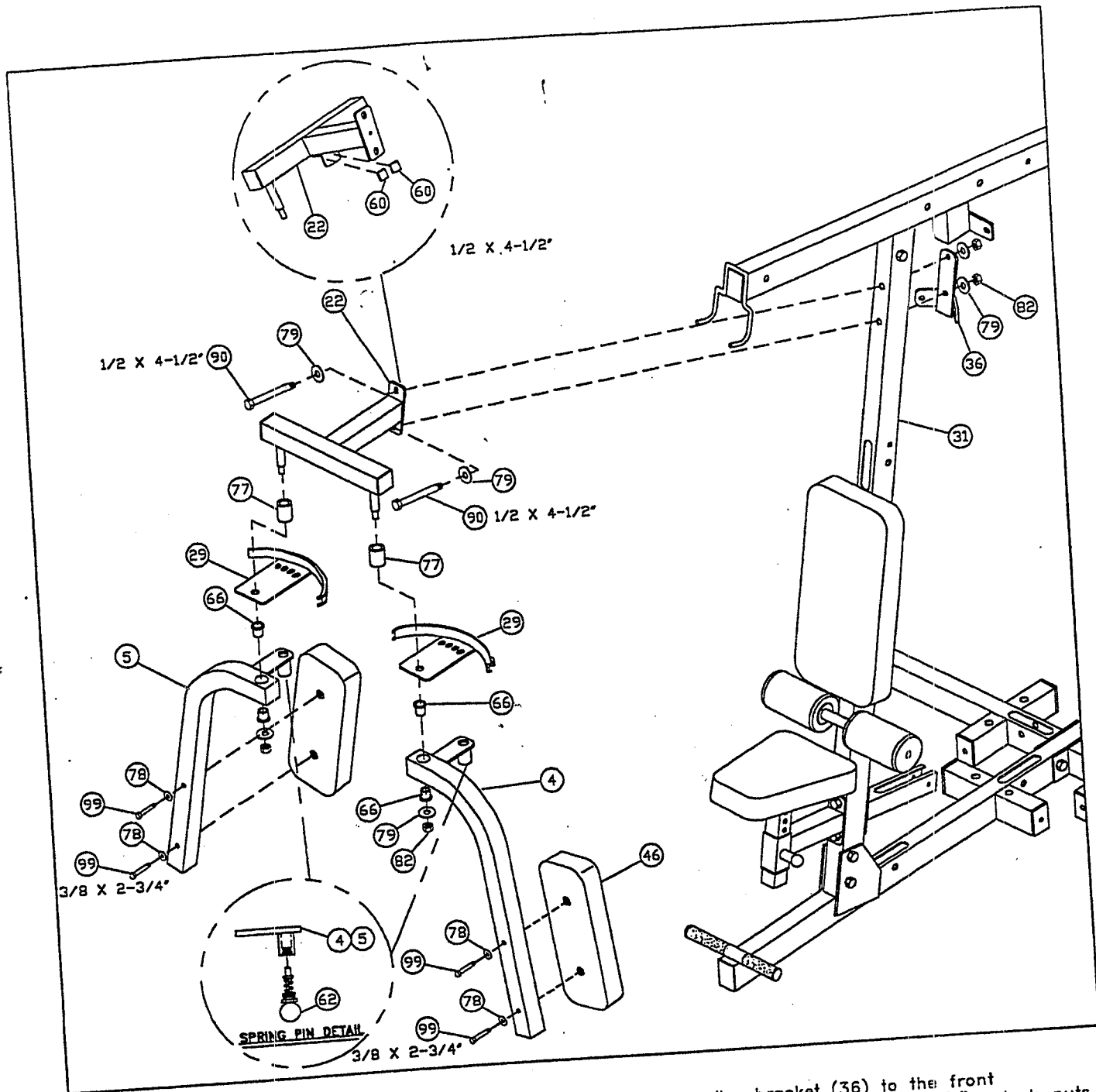

Step 3

- A. Securely assemble the bearing housing (22) and the center pulley bracket (36) to the front upright (31) using two 1/2 x 4-1/2" bolts (90), four 1/2" washers (79), and two 1/2" nylock nuts (82). (Note: Push bearing housing up as high as possible before tightening.)
- B. Assemble the right pec arm (4) and one pec cam (29) to the bearing housing (22) using one sleeve bearing (77), two 3/4" flange bearings (66), one 1/2" washer (79), and one 1/2" nylock nut (82). (Note: Securely tighten, then back nut off 1/4 turn to allow the pec arm to rotate freely.)
- C. Assemble the left pec arm (5) and one pec cam (29) to the bearing housing (22) using one 3/4" sleeve bearing (77), two 3/4" flange bearings (66), one 1/2" washer (79), and one 1/2" nylock nut (82). (Note: Securely tighten, then back nut off 1/4 turn to allow the pec arm to rotate freely.)
- D. Securely assemble one 3/8" spring pin (62) to both the right pec arm (4) and the left pec arm (5) as shown.
- E. Apply two 1" x 1" glides (60) to the bearing housing (22) where the pec cams (29) come in contact with the bearing housing as shown.
- F. Securely attach one pec arm pad (46) to both the right pec arm (4) and left pec arm (5) using four 3/8 x 2-3/4" bolts (99) and four 3/8" washers (78).

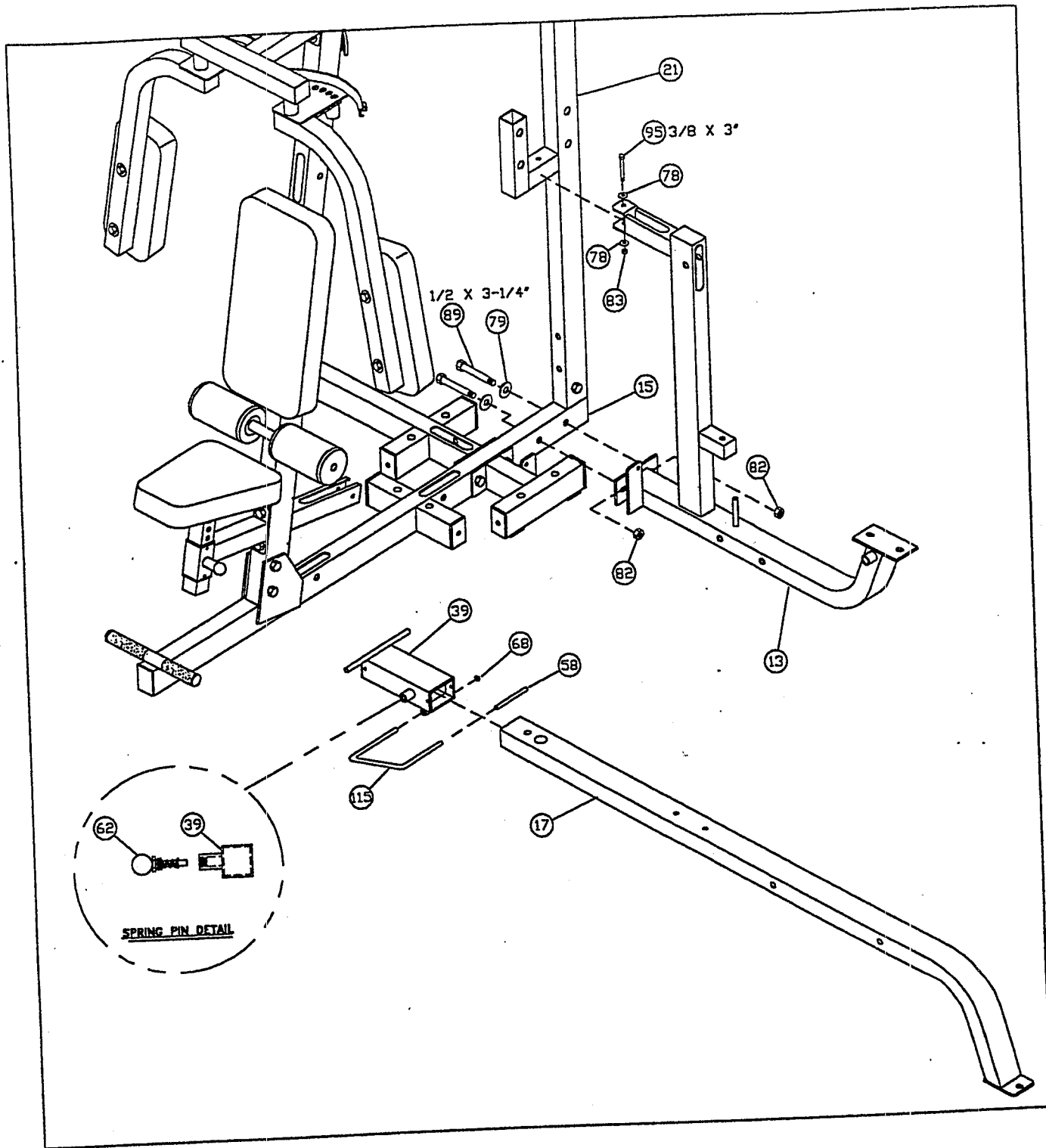

Step 4

- A. Securely attach the press base (13) to the base (15) using two 1/2 x 3-1/4" bolts (89), two 1/2" washers (79) and two 1/2" nylock nuts (82), and to the rear upright (21) using one 3/8 x 3" bolt (95), two 3/8" washers (78) and one 3/8" nylock nut (83).
- B. Securely assemble one 3/8" spring pin (62) to the wolff sleeve (39) as shown.
- C. Attach one u-pin (115) to the wolff sleeve (39) using one 1/2" pal nut (68). Slide one 4" vinyl cap (58) onto the u-pin as shown.
- D. Carefully slide assembled wolff sleeve (39) onto the press frame (17) until the spring pin engages in one of the holes.

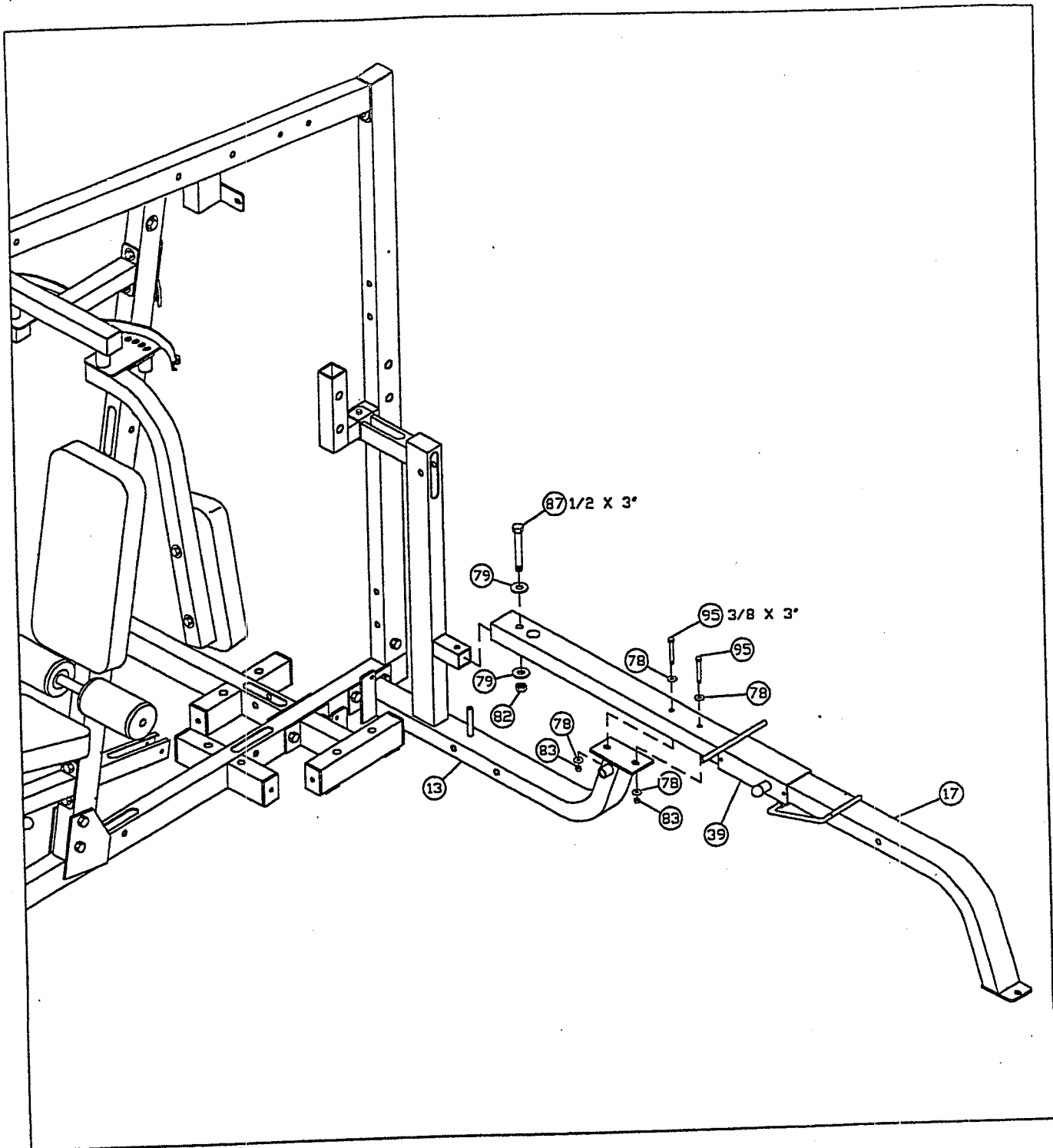

Step 5

- A. Securely attach the press frame (17) to the press base (13) using one 1/2 x 3" bolt (87), two 3/8 x 3" bolts (95), two 1/2" washers (79), four 3/8" washers (78), one 1/2" nylock nut (82), and two 3/8" nylock nuts (83). (Note: Make sure 3/8" bolts are facing down.)

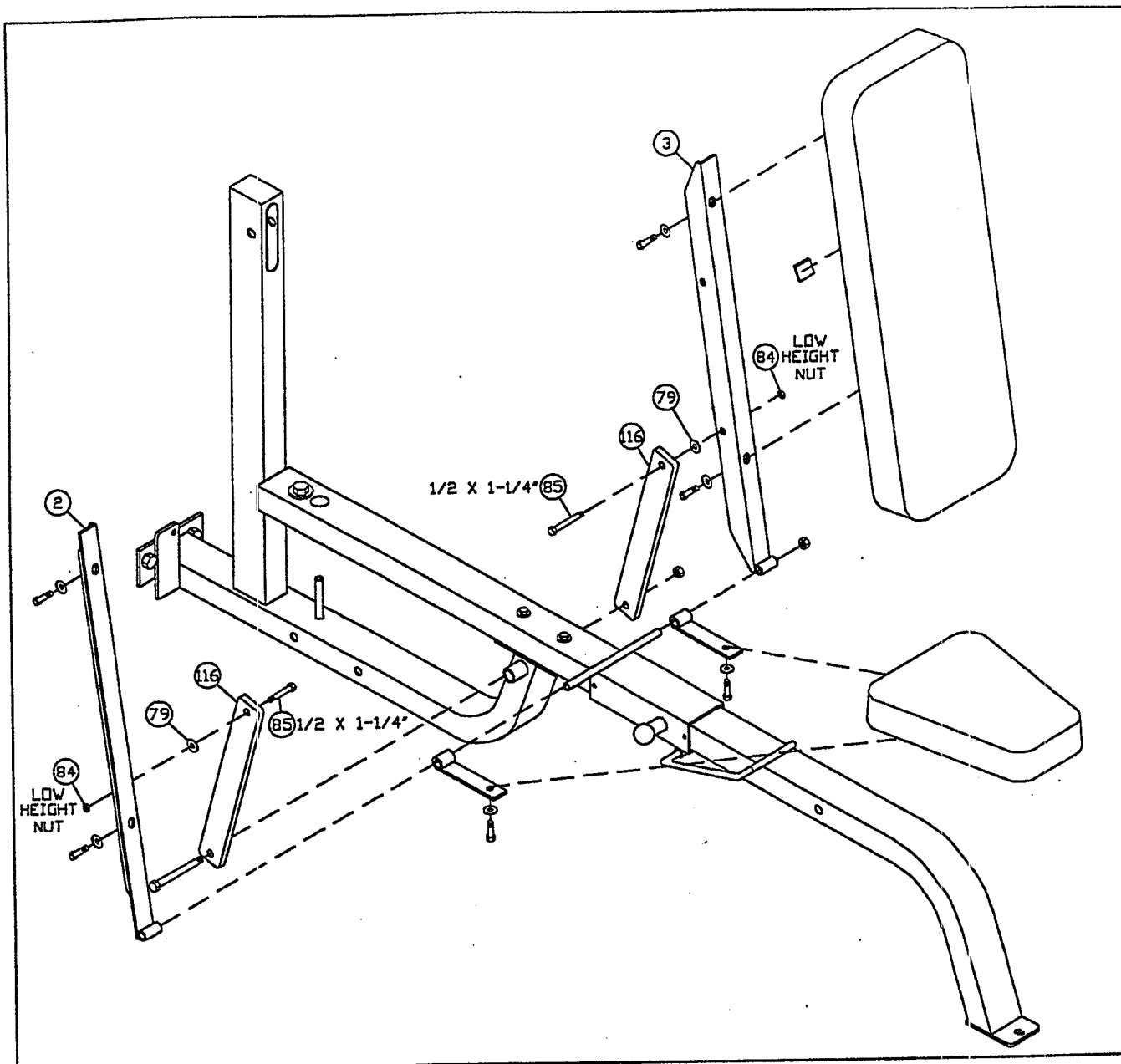

Step 6

- A. Slide two hinge tabs (73) onto the wolff sleeve (39) and securely attach press seat pad (49) using two 3/8 x 1" bolts (97), and two 3/8" washers (78). (Note: The "hinge" part of the hinge tab should face upward.)
- B. Slide the right back pad angle (2) and left back pad angle (3) onto the wolff sleeve (39) and attach the press back pad (50) using four 3/8 x 1" bolts (97), and four 3/8" washers (78).
- C. Secure the 1/2 x 2 x 15-1/2" plate (116) to right back pad angle (2) and the left back pad angle (3) using two 1/2 x 1-1/4" bolts (85), two 1/2" washers (79), and two 1/2" low height nylock nuts (84). Secure nuts, then back off 1/4 turn.)
- D. Secure the 1/2 x 2 x 15-1/2" plate (116) to bushing in press base (13) using one 1/2 x 6-1/2" bolt (94) and one 1/2" nylock nut (82). Secure nut, then back off 1/4 turn.
- E. Apply one rubber bumper (56) to the back of the press back pad (50) where the pad comes in contact with the rear bolt.

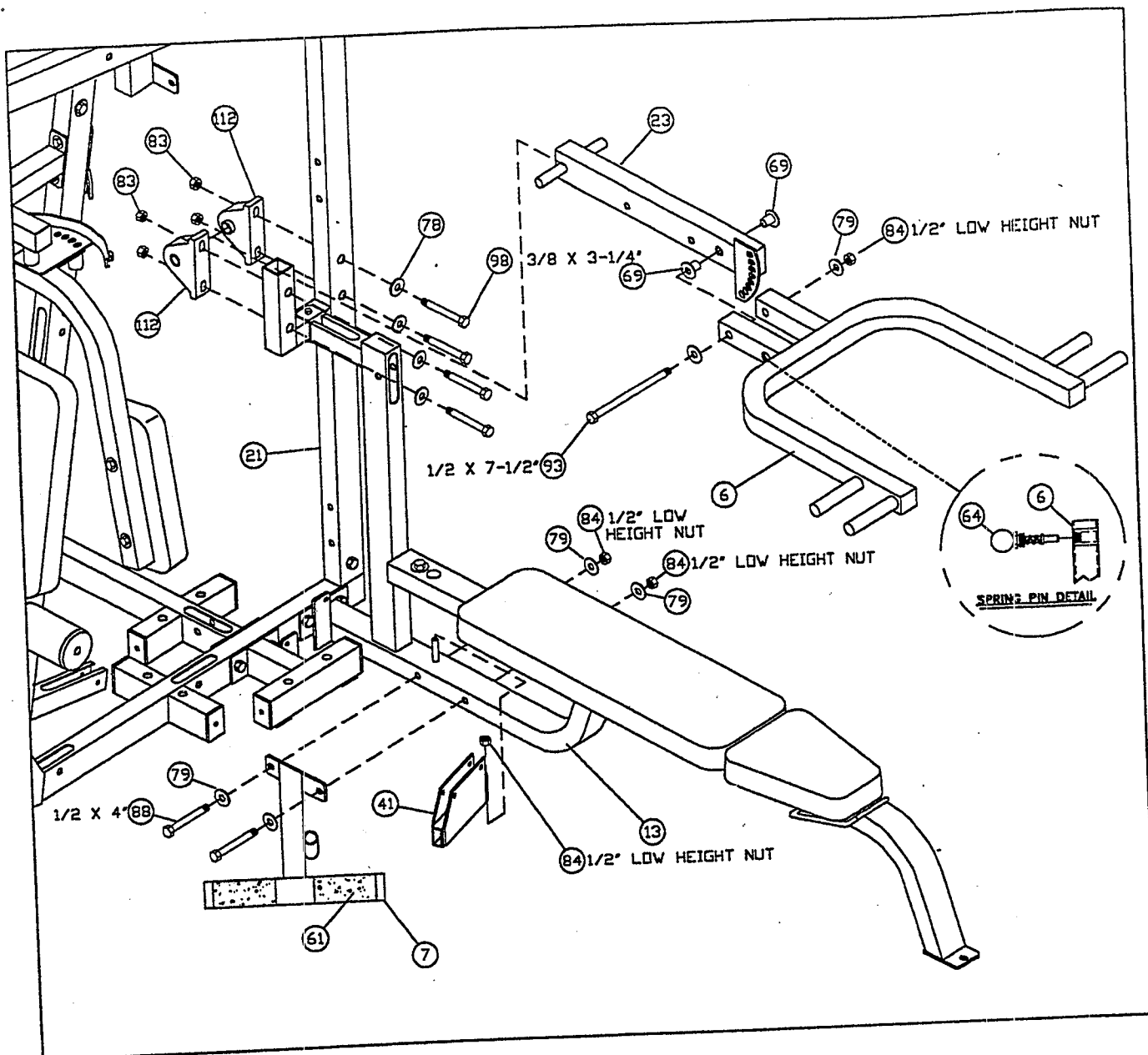

Step 7

- A. Loosely attach the press arm adjust (23) to the rear upright (21) using two 1" pillow block bearings (112), four 3/8 x 3-1/4" bolts (98), four 3/8" washers (78), and four 3/8" nylock nuts (83). (Note: Attach pillow block bearings (112) so the set screws are on the inside, this will allow more adjustment.)
- B. Center press arm adjust (23) to line up with the post on the press base (13) and securely tighten set screws on the pillow block bearings (112).
- C. Adjust pillow block bearings (112) until the press arm adjust (23) is level and securely tighten bolts.
- D. Securely assemble one 1/2" spring pin (64) to the press arm (6) as shown.
- E. Securely attach the press arm (6) to the press arm adjust (23) using one 1/2 x 7-1/2" bolt (93), two 1/2" washers (79), two 1/2" flange bearings (69), and one 1/2" low height nylock nut (84). (Note: Securely tighten, then back nut off 1/4 turn to allow the press arm to rotate freely.)
- F. Securely attach calf/low row (7) to the press base (13) using two 1/2 x 4" bolts (88), four 1/2" washers (79), and two 1/2" low height nylock nuts (84). Apply two non-skid strips (61) to the calf / low row as shown.
- G. Attach swivel pulley bracket (41) to the press base (13) using one 1/2" low height nylock nut (84). (Note: Securely tighten, then back nut off 1/4 turn to allow the swivel pulley bracket to rotate freely.)

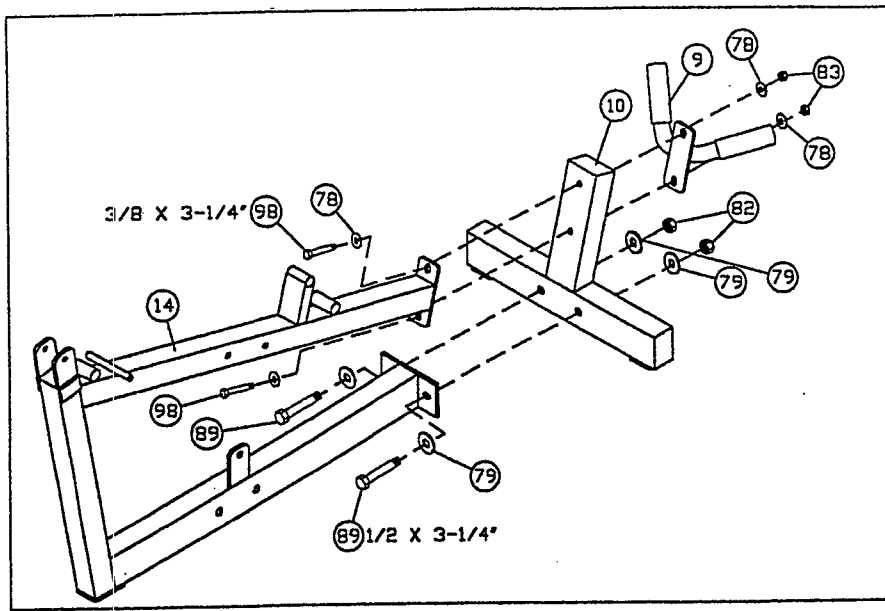

Step 8

- A. Securely attach the rear leg base (10) and the leg curl handle (9) to the leg frame (14) using two $1/2 \times 3-1/4$ bolts (89), two $3/8 \times 3-1/4$ bolts (98), four $1/2$ washers (79), four $3/8$ washers (78), two $1/2$ nylock nuts (82), and two $3/8$ nylock nuts (83).

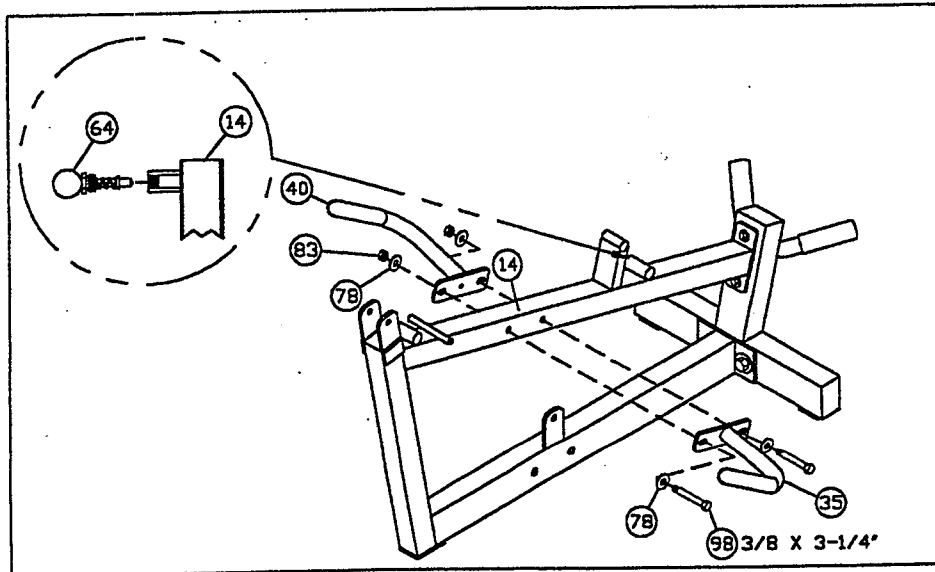

- B. Securely attach the right (35) & left (40) leg extension handles (35) to the leg frame (14) using two $3/8 \times 3-1/4$ bolts (98), four $3/8$ washers (78), and two $3/8$ nylock nuts (83).
- C. Securely assemble one $1/2$ spring pin (64) to the leg frame (14) as shown.

- D. Securely attach one $1/8 \times 2 \times 8$ plate (37) to the leg seat pad (47) using two $3/8 \times 1$ bolts (97), and two $3/8$ washers (78).

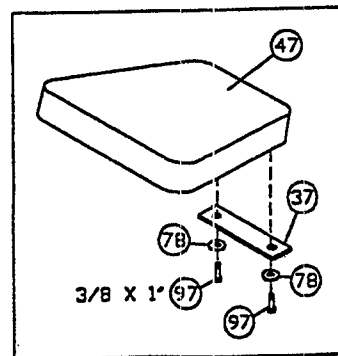

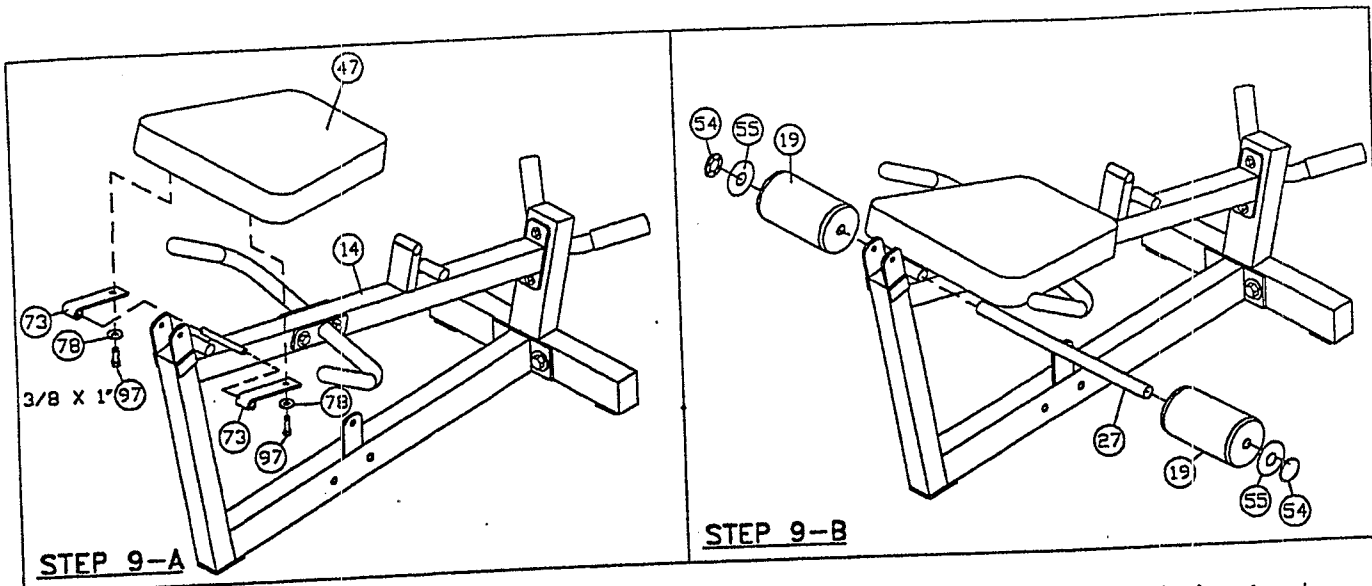

STEP 9

- Slide two hinge tabs (73) onto the leg frame (14) and securely attach leg seat pad (47) using two 3/8 x 1" bolts (97), and two 3/8" washers (78). (Note: The "hinge" part of the hinge tab should face downward.)
- Attach two roller pads (19) to the leg frame (14) using one 16-3/4" roller pad shaft (27), two plastic washers (55) and two 3/4" starlock collars (54) as shown

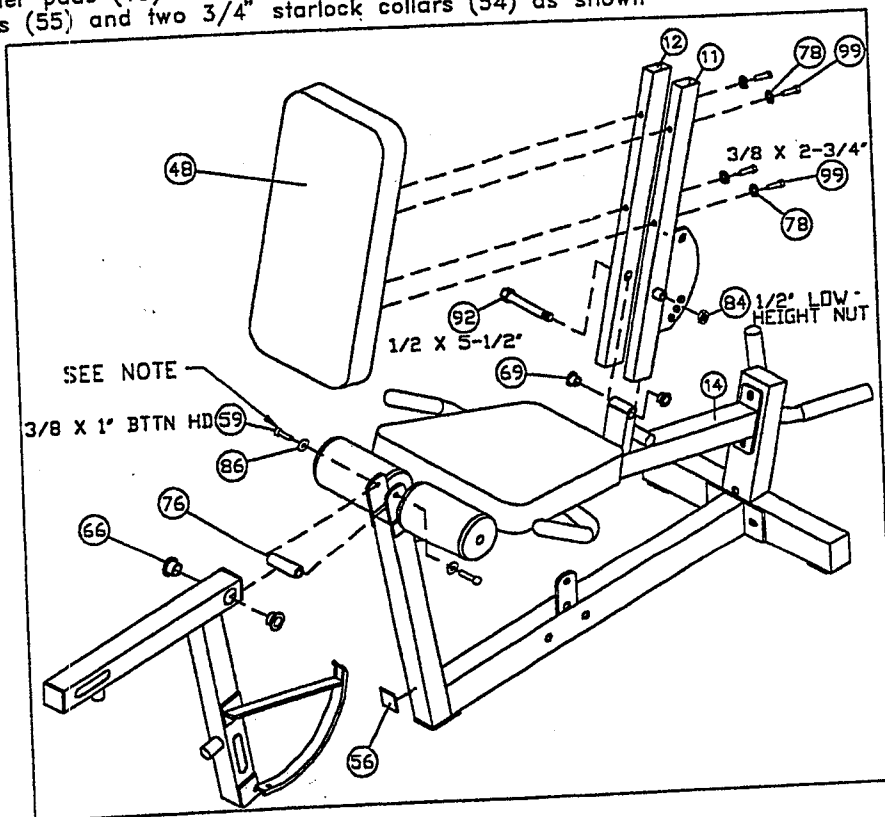

STEP 10

- Attach leg back pad adjust (11), and leg back pad support (12) to the leg frame (14) using one 1/2 x 5-1/2" bolt (92), two 1/2" flange bearings (69) and one 1/2" low height lock nut (84) as shown. (Note: Securely tighten, then back nut off 1/4 turn to allow the two parts to rotate freely.)
 - Securely attach the leg back pad (48) to the leg back pad adjust (11), and leg back pad support (12), using four 3/8 x 2-3/4" bolts (99) and four 3/8" washers (78).
 - Securely attach leg curl/extension (8) to the leg frame (14) using two 3/4" flange bearings (66), one 3/4" tapped axle (76), two 3/8" black lock washers (86), and two 3/8 x 1" black button head cap screws (59).
- NOTE: BOTH CAP SCREWS MUST BE TIGHTENED AT THE SAME TIME USING TWO ALLEN WRENCHES.**
- Securely attach rubber bumper (56) between contact point of leg curl/extension (8) and leg frame (14) as shown.

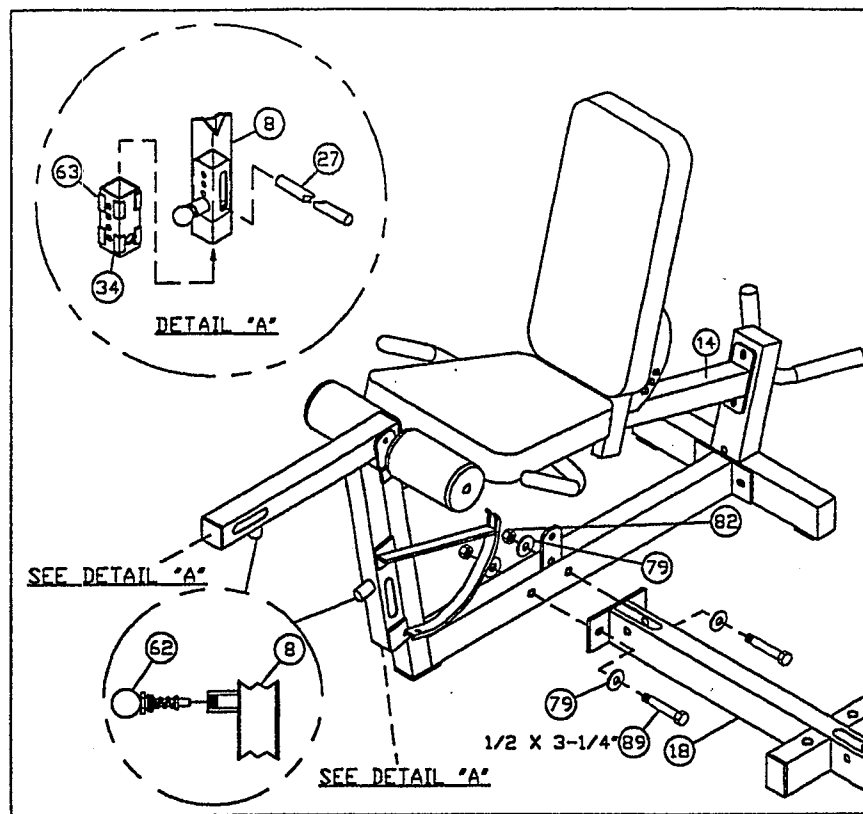

STEP 11.

- A. Securely assemble two 3/8" spring pins (62) to the leg curl/extension (8) as shown.
- B. Apply eight 1-1/2 x 3/4" glides (63) to the outside surfaces of each roller pad adjuster (34) as shown, and insert roller pad adjusters (34) into the leg curl/extension (8). (Note: The end caps will need to be temporarily removed.)
- C. Securely assemble leg frame (14) to the leg weight stack base (18) using two 1/2 x 3-1/4" bolts (89), four 1/2" washers (79), and two 1/2" nylock nuts (82).

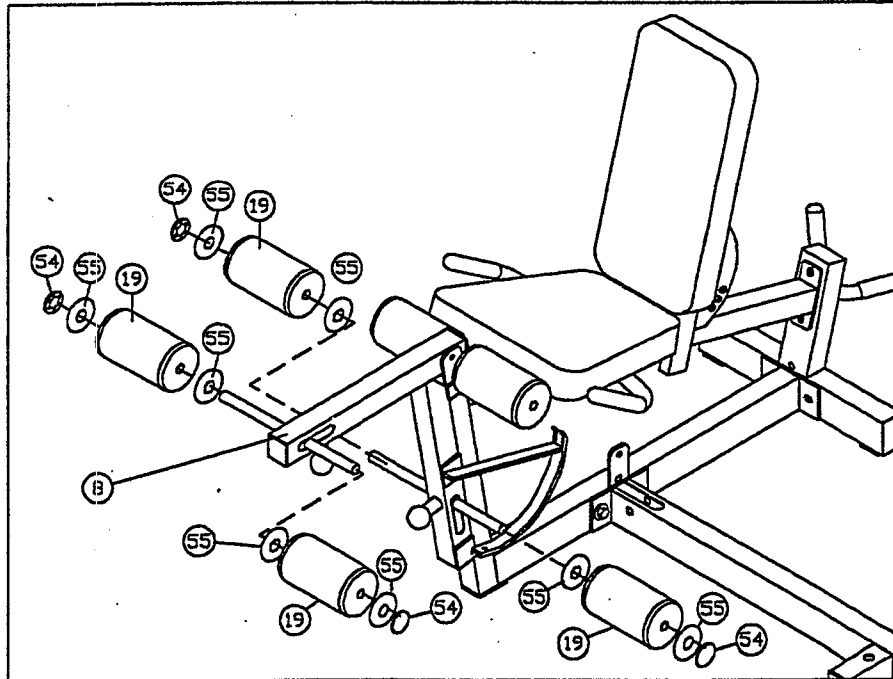

- D. Attach four roller pads (19) to the leg curl/extension (8) and roller pad adjusters (34) using two 16-3/4" roller pad shafts (27), eight plastic washers (55) and four 3/4" starlock collars (54) as shown.

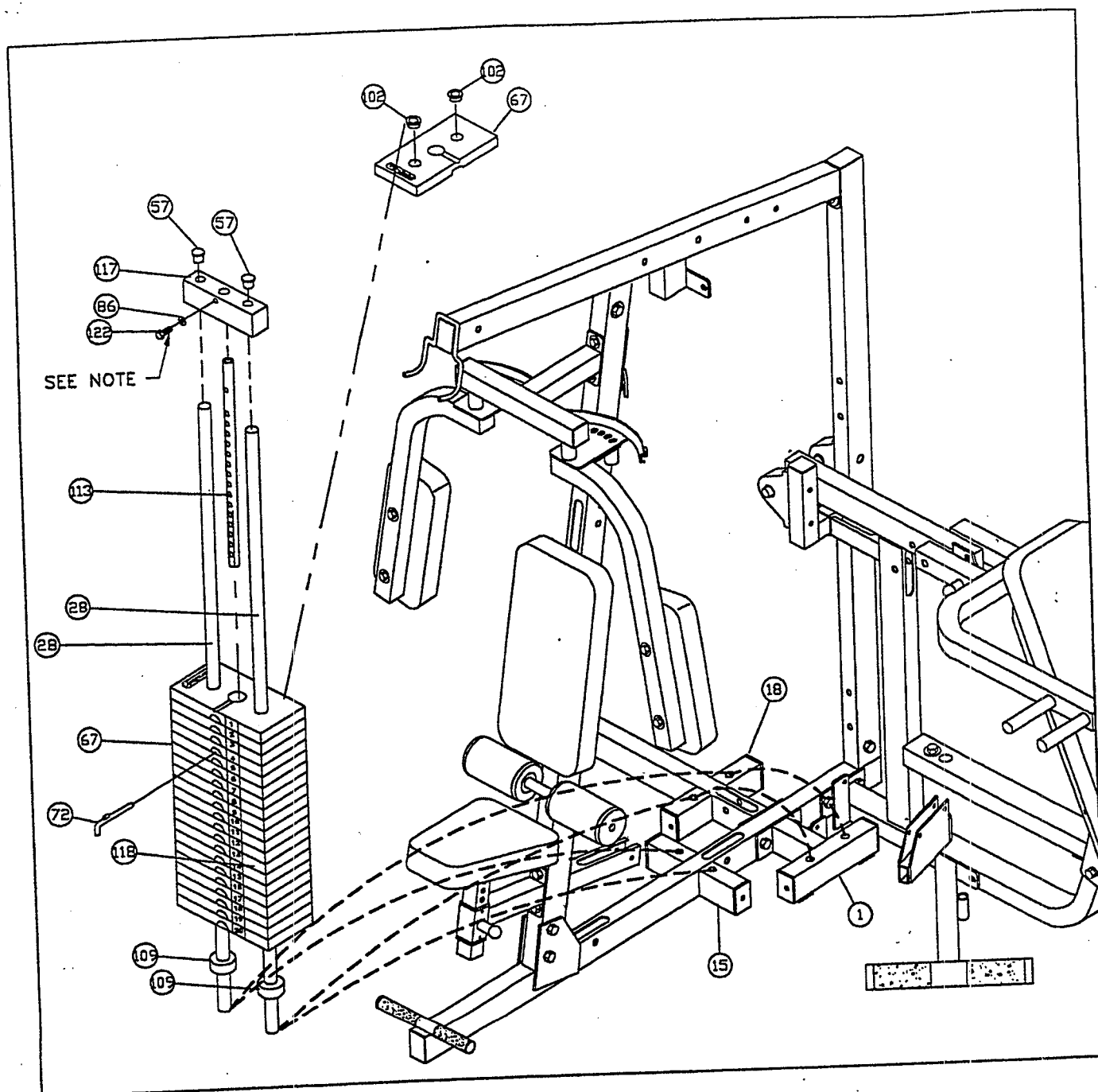

Step 12

- A. Insert two plate bushings (102) into the "ParaBody" side of each of sixty weight plates (67) as shown.
- B. Insert one guide rod (28) through one weight stack cushion (109) and into each of the large holes in the base (15), the leg weight stack base (18), and the press weight stack press (1) as shown.
- C. Carefully slide twenty weight plates (67) onto each set of guide rods (28) with the "ParaBody" side up and the center key-hole facing outward.
- D. Securely assemble one selector shaft (113) to one head plate (117) using one 3/8" black lock washer (86), and one 3/8 x 1-1/4" bolt (122). Repeat this step for the other two head plates. **(NOTE: THE BOLT HOLE IN THE HEAD PLATE SHOULD BE ON TOP)**
- E. Carefully slide one head plate assembly over each set of guide rods and onto each top weight plate as shown.
- F. Insert one cap plug (57) into each guide rod (28).
- G. Apply one weight stack label (118) onto each weight plate (67) as shown. Labels 1 through 20 should be applied from top to bottom of the weight stack and close to the key-hole.

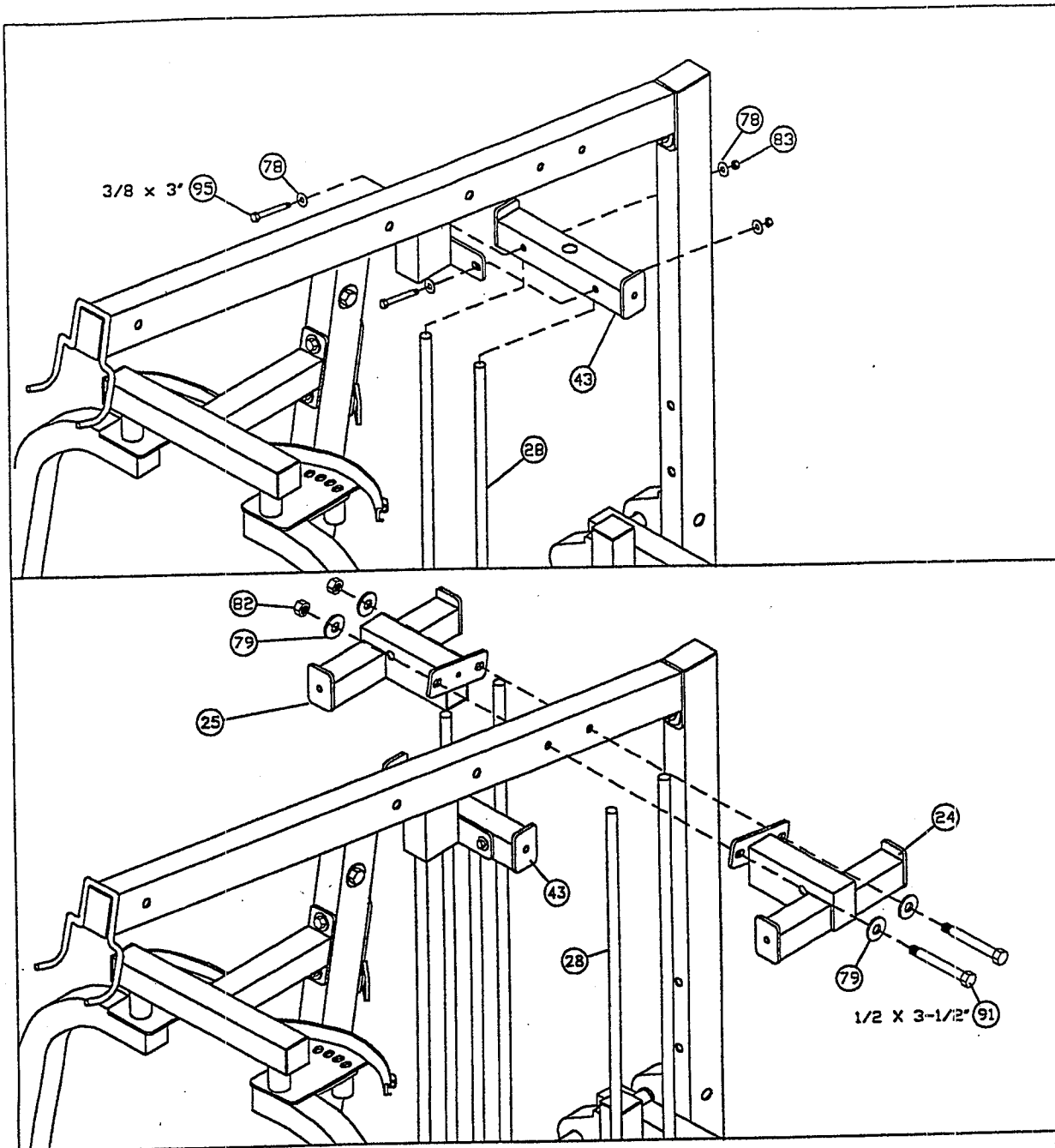

Step 13

- A. Slide pec guide rod support (43) onto the pec weight stack guide rods and loosely attach it to the boom using two 3/8 x 3" bolts (95), four 3/8" washers (78), and two 3/8" nylock nuts (83). (Note: This connection will be secured in a later step after the pulleys are assembled.)
- B. Slide press guide rod support (24) and leg guide rod support (25) over their respective guide rods and securely assemble them to the boom using two 1/2 x 3-1/2" bolts (91), four 1/2" washers (79), and two 1/2" nylock nuts (82).

CABLE GUIDE

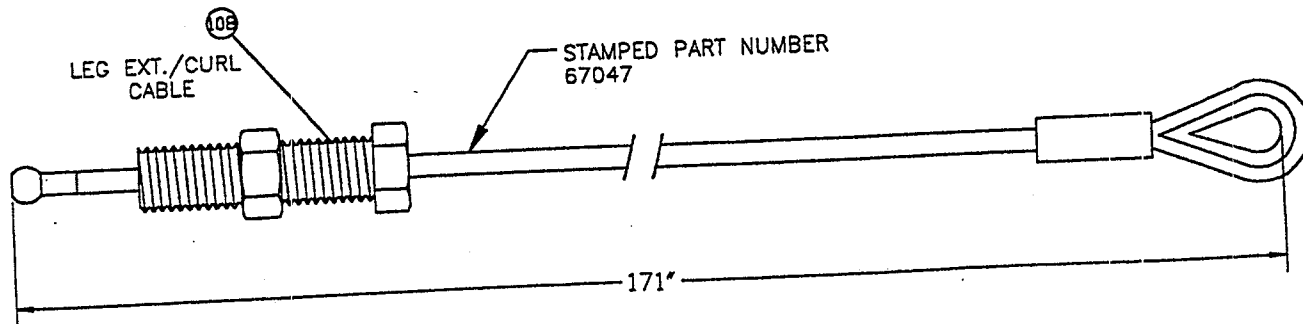
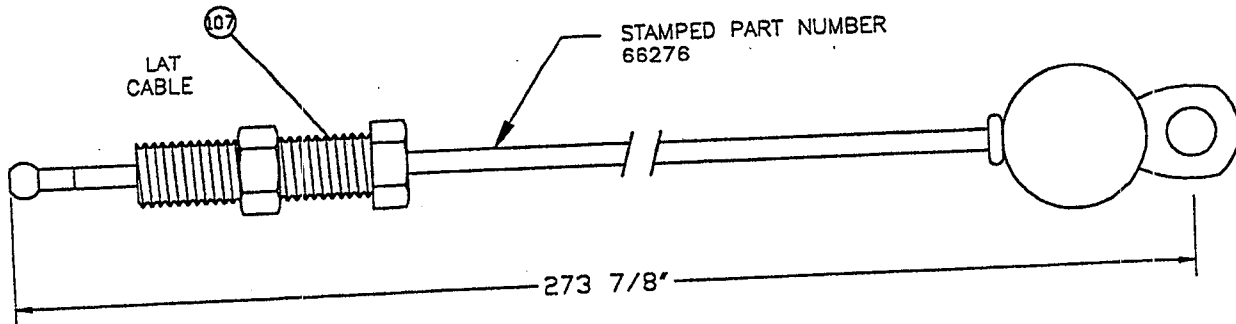
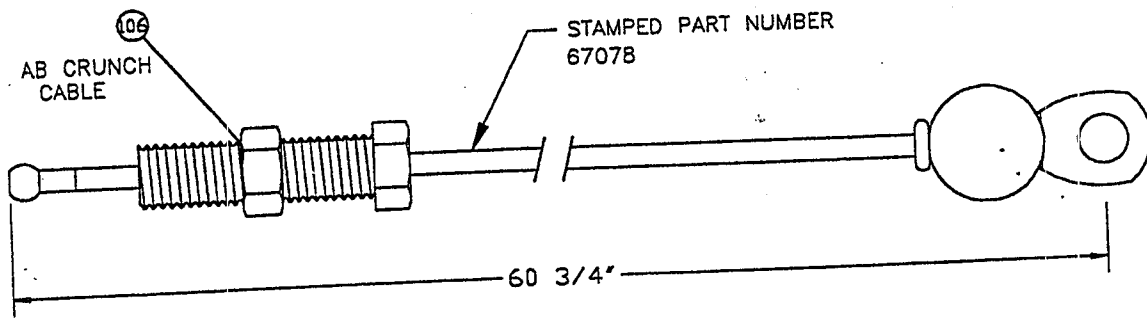
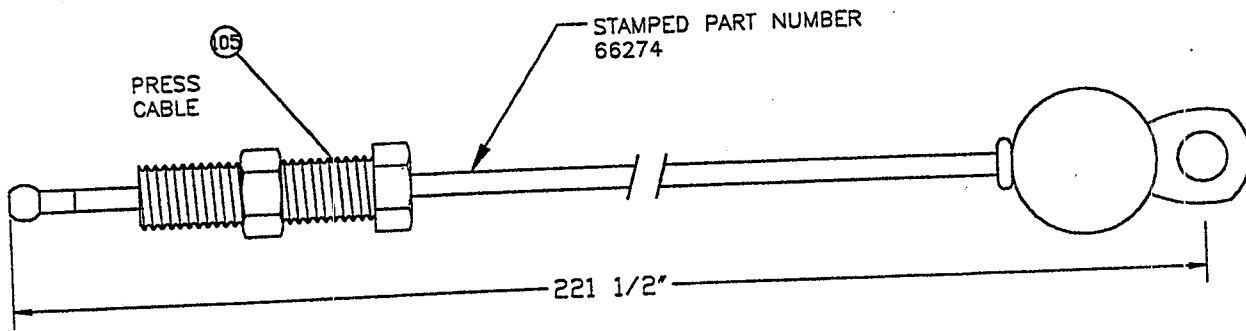
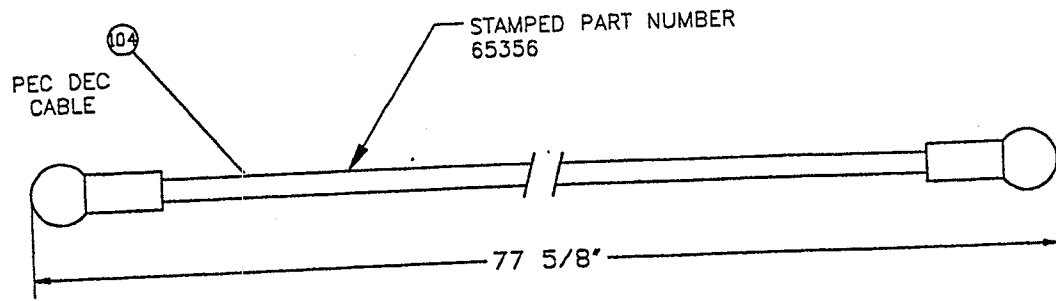

Pec Dec Cable Assembly Instructions

Use this procedure to assemble the pec dec cables of the ParaBody 950ST

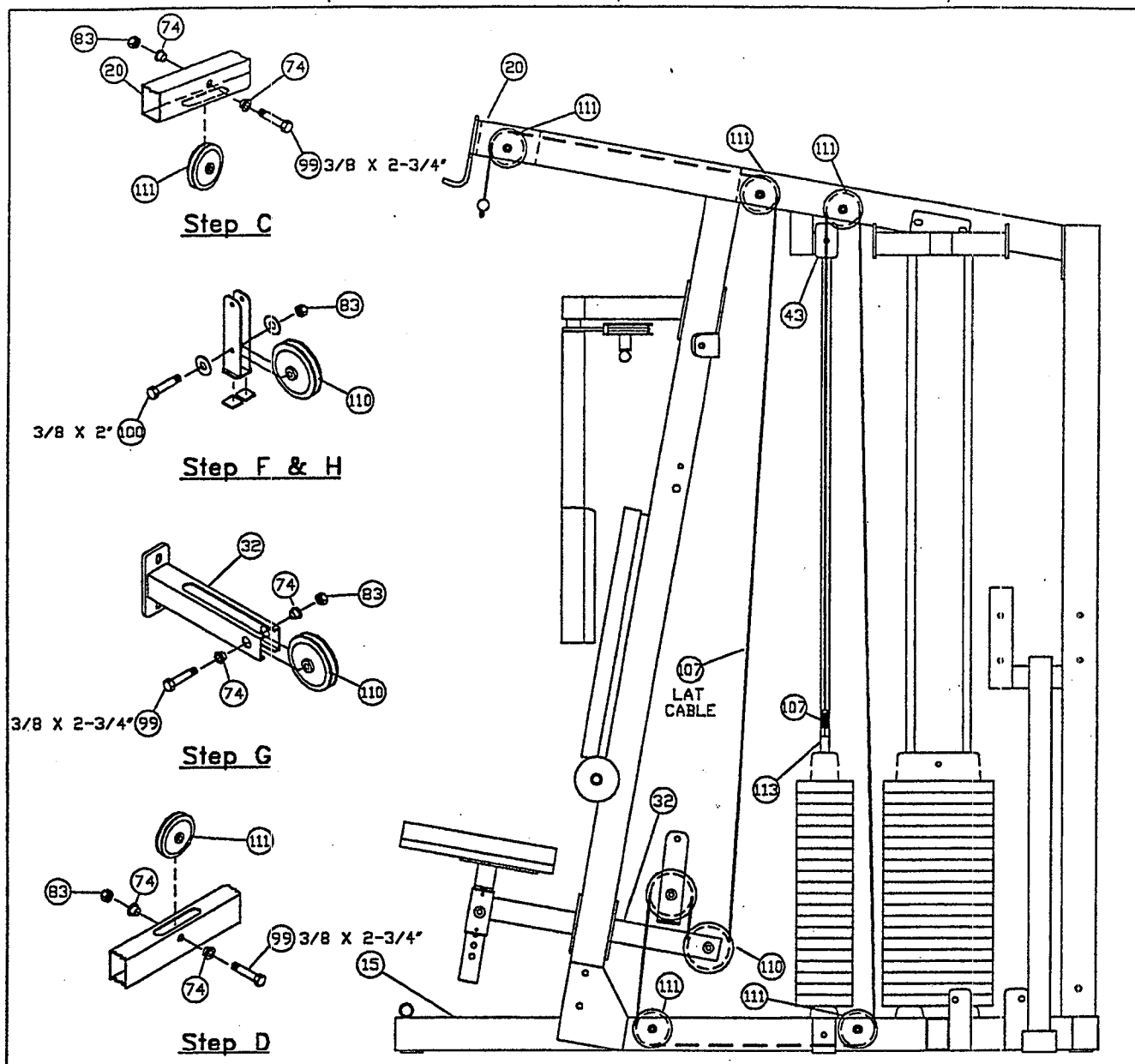

Step 1

- A. In this order, route the threaded end of the lat cable (107) through the top boom (20), the base (15), and the large hole in the pec guide rod support (43).
- B. Screw the threaded end of the lat cable (107) approximately 3/4" into the end of the selector shaft (113) and tighten jam nut securely as shown.
- C. Securely assemble three 3-1/2" pulleys (111) into the slots of the top boom (20) using three 3/8 x 2-3/4" bolts (99), six 3/8" Flange Spacers (74), and three 3/8" nylock nuts (83). (Note: Loop the cable around each pulley prior to inserting it into the slot.)
- D. Securely assemble two 3-1/2" pulleys (111) into the slots of the base (15) using two 3/8 x 2-3/4" bolts (99), four 3/8" Flange Spacers (74), and two 3/8" nylock nuts (83). (Note: Loop the cable around each pulley prior to inserting it into the slot.)
- E. Securely tighten the bolts of the pec guide rod support (43) and top boom (20) connection at this time. (Note: Center the pec guide rod support horizontally and vertically before tightening.)
- F. Apply two 1" x 1" glides (60) to the floating pulley (30), as shown.
- G. Securely assemble one 4-1/2" pulley (110) to the floating pulley stop (32) using one 3/8 x 2-3/4" bolt (99), two 3/8" flange spacers (74), and one 3/8" nylock nut (83).
- H. Securely assemble one 4-1/2" pulley (110) to the floating pulley (30) using one 3/8 x 2" bolt (100), two 3/8" washers (78), and one 3/8" nylock nut (83). Loop cable around pulley and place the floating pulley (30) onto the floating pulley stop (32).

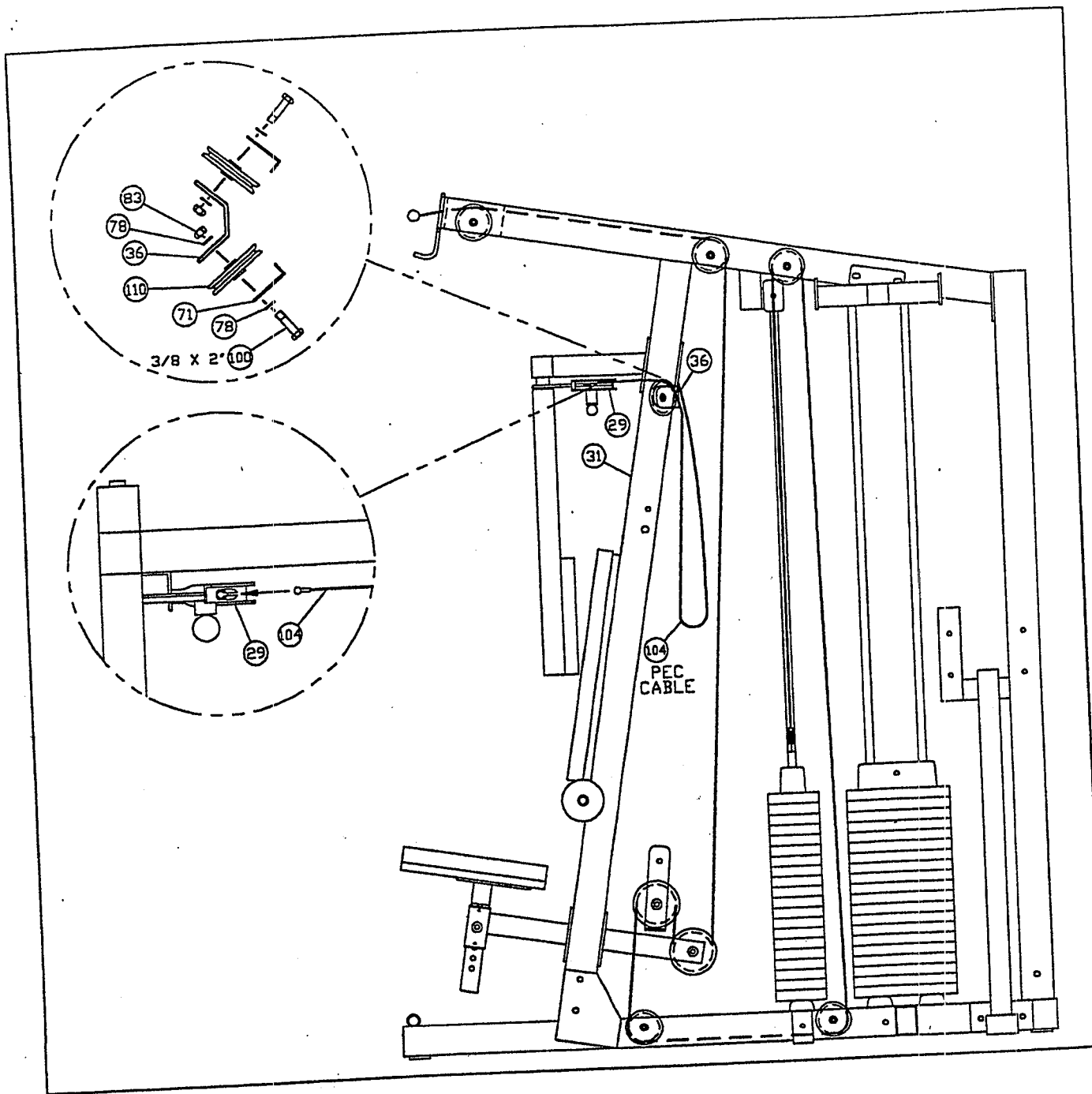

Step 2

- A. Connect one end of the pec dec cable (104) to the slotted bushing on the right pec cam (29). Route the other end of the pec dec cable around the front upright (31) and connect it to the slotted bushing on the left pec cam (29).
- B. Securely assemble the pec dec cable (104) and two 4-1/2" pulleys (110) to the center pulley bracket (36) using two 3/8 x 2" bolts (100), two 2-7/8" 'L' brackets (71), four 3/8" washers (78) and two 3/8" nylock nuts (83). (Note: The pec dec cable should be routed underneath the short leg of the 'L' bracket. Also the 'L' brackets should be positioned at a 45 degree angle to function properly.)

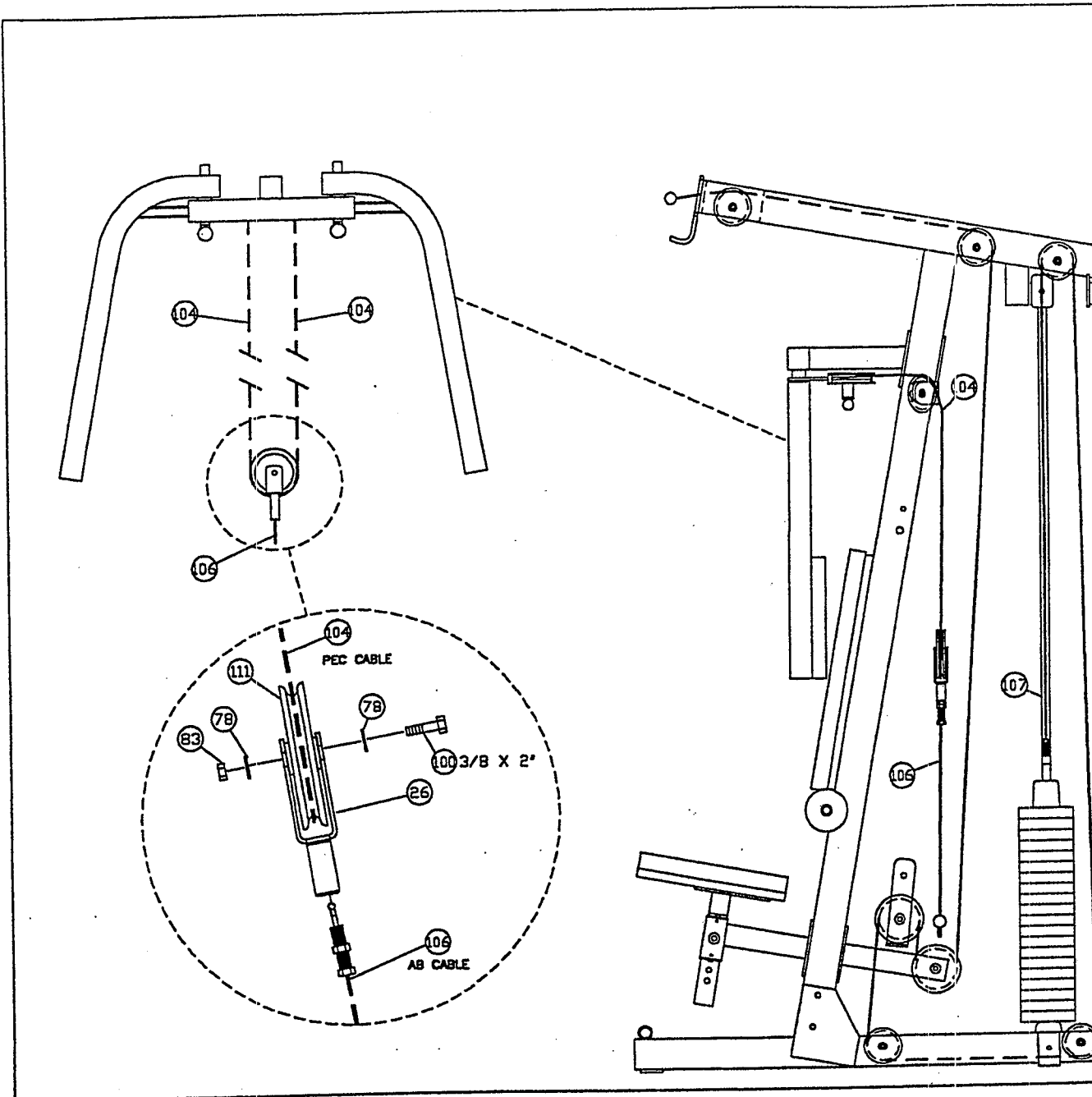

Step 3

- A. Securely assemble the threaded end of the ab crunch cable (106) approximately 3/4" into the end of the pulley bracket (26) and tighten jam nut securely.
- B. Securely assemble the pec dec cable (104) and one 3-1/2" pulley (111) to the pulley bracket (26) using one 3/8 x 2" bolt (100), two 3/8" washers (78), and one 3/8" nylock nut (83). (Note: Loop the cable around the pulley prior to inserting it into the 'U' bracket.)

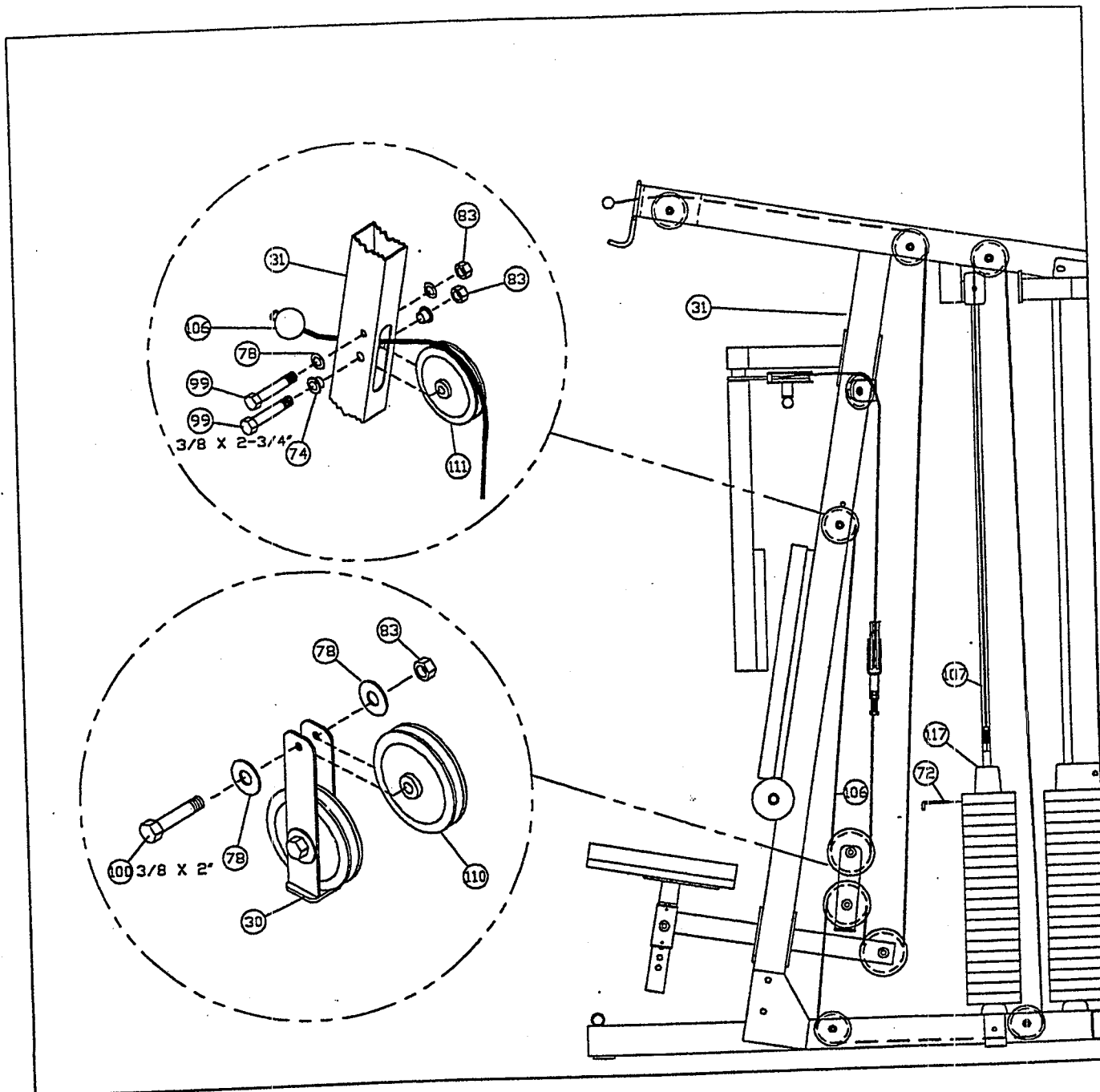

Step 4

- A. Securely assemble the ball end of the ab crunch cable (106) and one 3-1/2" pulley (111) to the front upright (31) using two 3/8 x 2-3/4" bolts (99), two 3/8" flange spacers (74), two 3/8" washers (78), and two 3/8" nylock nuts (83). (Note: The ab crunch cable should be routed underneath the retaining bolt as shown.)
- B. Securely assemble the ab crunch cable (106) and one 4-1/2" pulley (110) to the floating pulley (30), using one 3/8 x 2" bolt (100), two 3/8" washers (78), and one 3/8" nylock nut (83). (Note: Loop the cable around the pulley prior to inserting it into the floating pulley.)
- C. If upon completion of assembly, the head plate (117) does not sit on top of the first weight plate (67), push the head plate down, insert the selector pin (72) and perform several repetitions at the station. This will relax the cable system and prevent the head plate from lifting up.
- D. If after completing step E. the head plate still does not sit on top of the first weight plate or if there is excess slack in the cable system, adjust the threaded end of the lat cable (107) accordingly and retighten the jam nut.

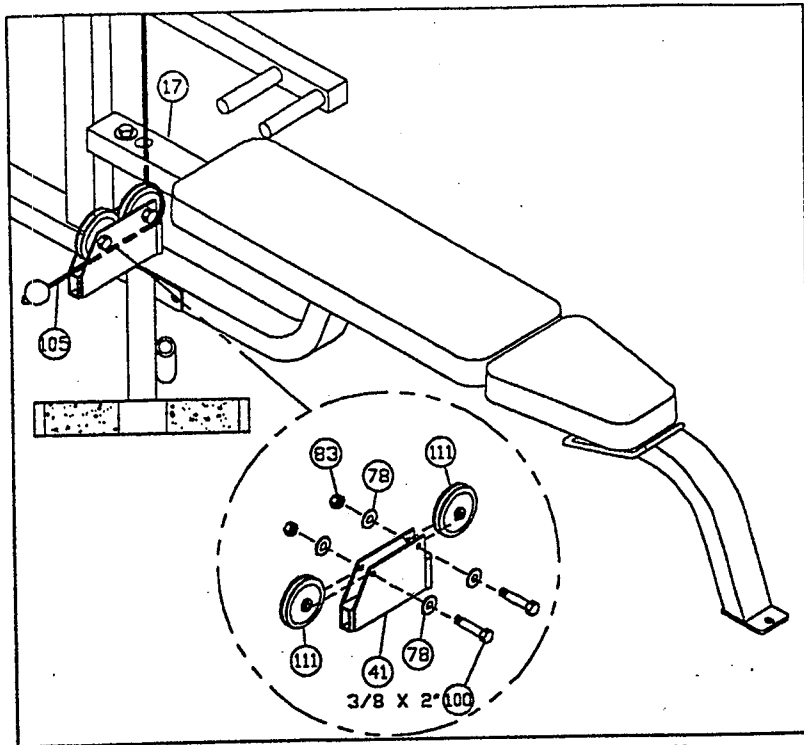

Press Station Cable Assembly Instructions

Use this procedure to assemble the press station cable of the ParaBody 950ST

Step 1

- A. Secure the ball end of the press cable (105) and two 3-1/2" pulleys (111) to the swivel pulley bracket (41) using two 3/8 x 2" bolts (100), four 3/8" washers (78), and two 3/8" nylock nuts (83). (Note: Loop the cable around the pulley prior to inserting it into the swivel pulley bracket.)
- B. Route the threaded end of the press cable (105) through the large hole in the press frame (17) and secure to the front slot of the press arm adjust (23) using one 3-1/2" pulley (111), one 3/8 x 2-3/4" bolt (99), two 3/8" flange spacers (74), and one 3/8" nylock nut (83). (Note: Loop the cable over the pulley prior to inserting it into the slot.)
- C. Secure the press cable (105) and one 4-1/2" pulley (110) to the press base (13), using one 3/8 x 2-3/4" bolt (99), two 3/8" flange spacers (74), and one 3/8" nylock nut (83). (Note: Loop the cable under the pulley prior to inserting it into the slot.)
- D. Secure the press cable (105) and one 3-1/2" pulley (111) to the rear slot of the press arm adjust (23), using one 3/8 x 2-3/4" bolt (99), two 3/8" flange spacers (74), and one 3/8" nylock nut (83). (Note: Loop the cable over the pulley prior to inserting it into the slot.)

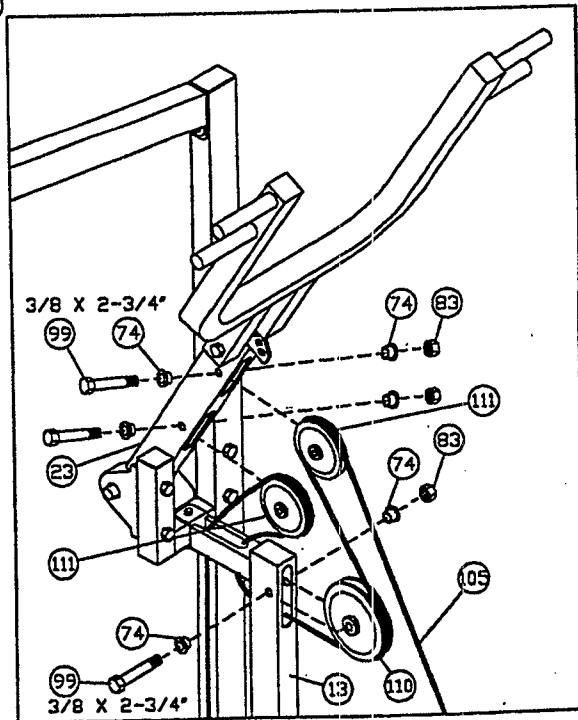
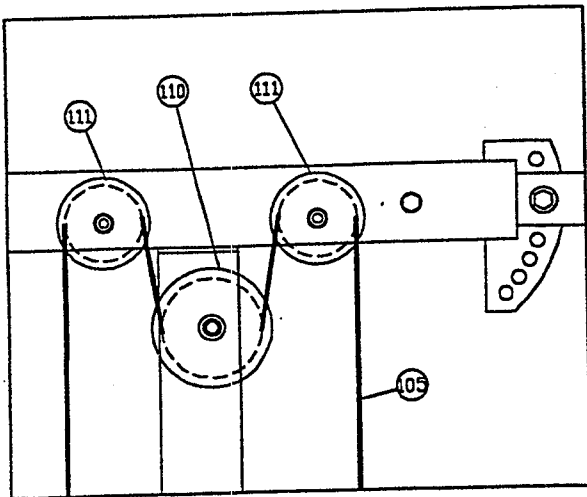

Step 2

- A. Secure the press cable (105) and two 3-1/2" pulleys (111) to the pulley flats on the press base (13) and the press weight stack base (1) using two 3/8 x 2" bolts (100), two 2-3/8" 'L' brackets (75), four 3/8" washers (78), and two 3/8" nylock nuts (83). (Note: The press cable should be routed underneath the short leg of the 'L' bracket. Also the 'L' brackets should be positioned straight down to function properly.)

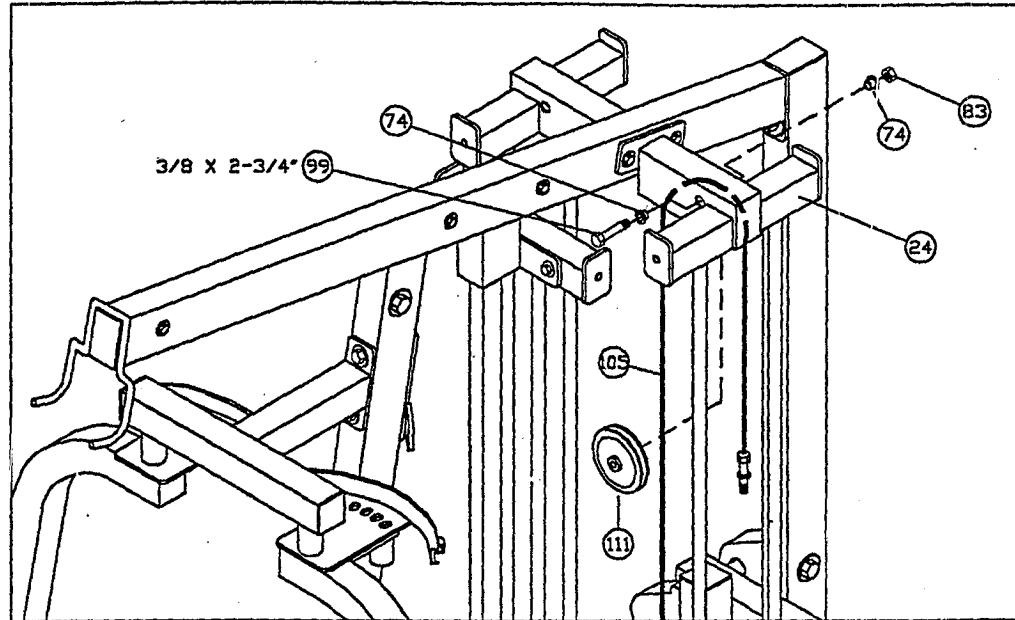
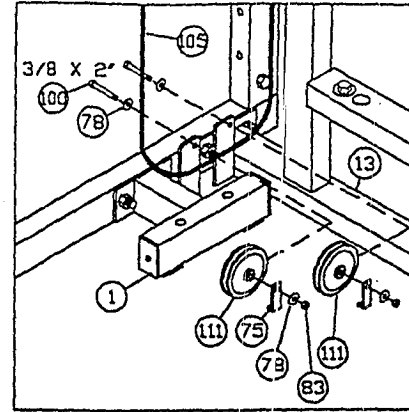

- B. Secure the press cable (105) and one 3-1/2" pulley (111) to the press guide rod support (24) using one 3/8 x 2-3/4" bolt (99), two 3/8" flange spacers (74), and one 3/8" nylock nut (83). (Note: Loop the cable over the pulley prior to inserting it)

- C. Screw the threaded end of the press cable (105) approximately 3/4" into the end of the selector shaft (113) and tighten jam nut securely as shown.

- D. If upon completion of assembly, the head plate (117) does not sit on top of the first weight plate (67), push the head plate down, insert the selector pin (72) and perform several repetitions at the station. This will relax the cable system and prevent the head plate from lifting up.

- E. If after completing step D. the head plate still does not sit on top of the first weight plate or if there is excess slack in the cable system, adjust the threaded end of the cable accordingly and retighten the jam nut.

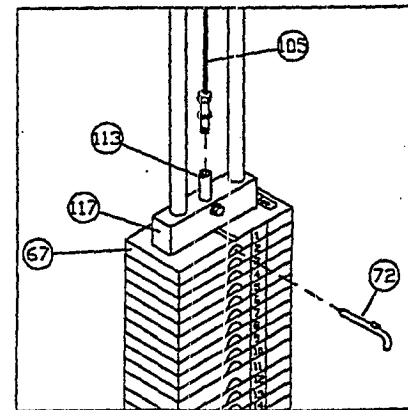

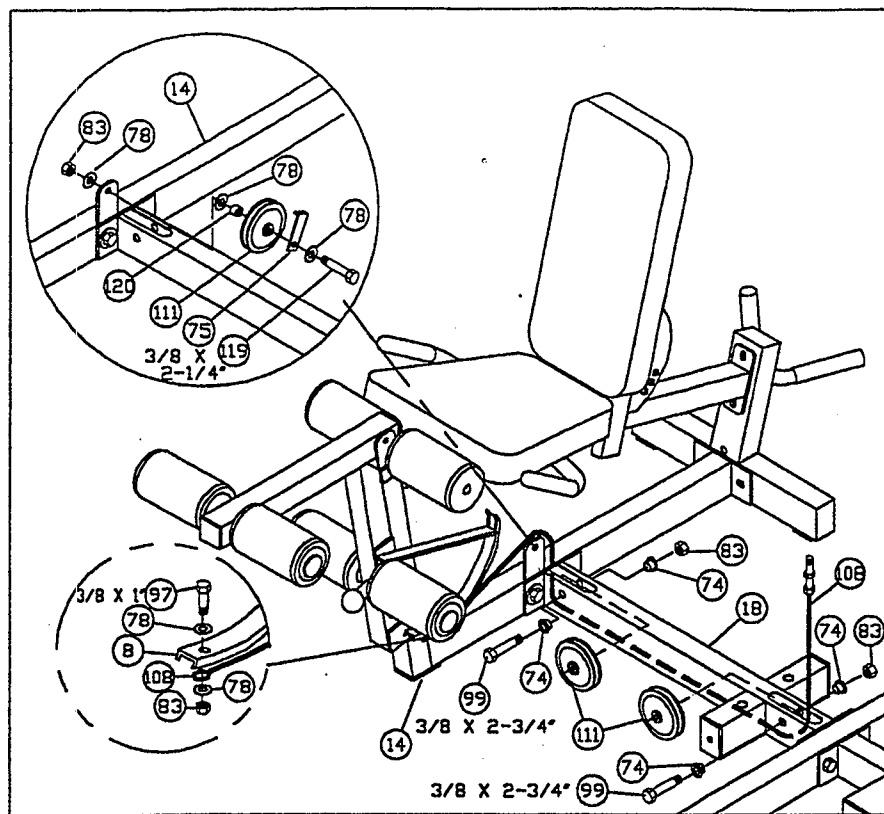

Leg Station Cable Assembly Instructions

Use this procedure to assemble the leg station cable of the PARABODY 950 ST

STEP 1

- A. Route the "loop" end of the leg cable (108) into the rear slot of the leg weight stack base (18) behind the weight stack, and out through the slot near the leg station.
- B. Securely attach the "loop" end of the leg cable (108), to the cam on the leg curl/extension (8), using one 3/8 x 1" bolt (97), two 3/8" washers (78), and one 3/8" nylock nut (83).
- C. Secure the leg cable (108) and one 3-1/2" pulley (111) to the pulley flat on the leg frame (14) using one 3/8 x 2-1/4" bolt (119), one 2-3/8" 'L' bracket (75), three 3/8" washers (78), one 1/4" spacer (120), and one 3/8" nylock nut (83). (Note: The leg cable should be routed underneath the short leg of the 'L' bracket and over the top of the pulley. Also the 'L' bracket should be positioned at a 45 degree angle to function properly.)
- D. Secure the leg cable (108) and two 3-1/2" pulleys (111) to the leg weight stack base (18) using two 3/8 x 2-3/4" bolts (99), four 3/8" flange spacers (74), and two 3/8" nylock nuts (83). (Note: Loop cable under the pulley prior to inserting it into the slot.)
- E. Secure the leg cable (108) and one 3-1/2" pulley (111) to the leg guide rod support (25) using one 3/8 x 2-3/4" bolt (99), two 3/8" flange spacers (74), and one 3/8" nylock nut (83). (Note: Loop the cable over the pulley prior to inserting it in the slot.)

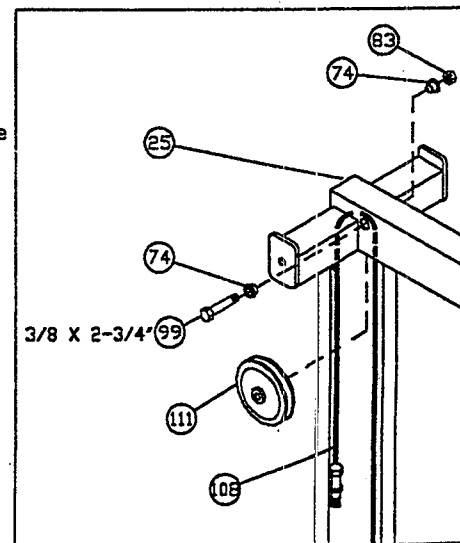

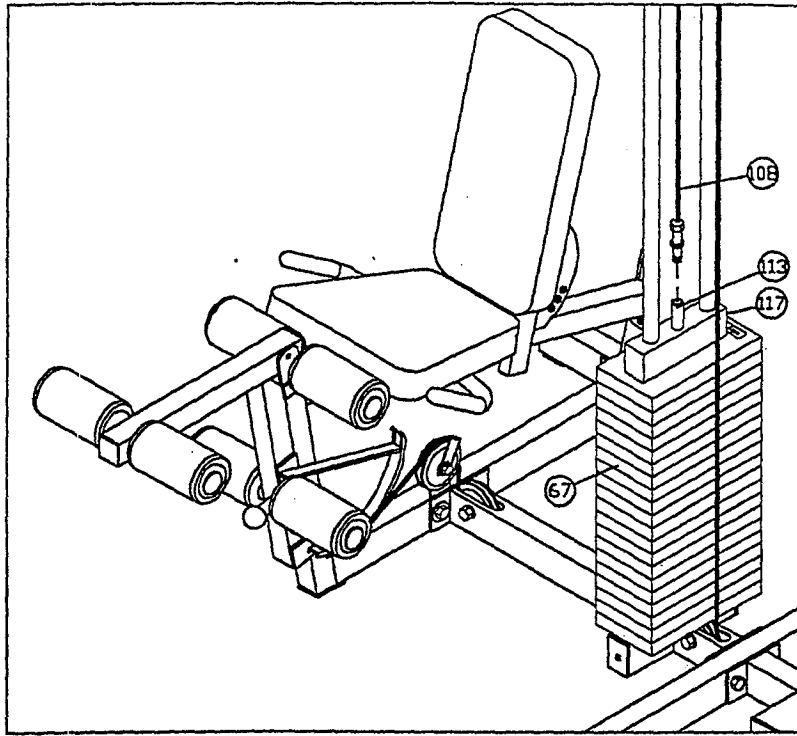

STEP 2

- A. Screw the threaded end of the leg cable (108) approximately 3/4" into the end of the selector shaft (113) and tighten jam nut securely as shown.
- B. If upon completion of assembly, the head plate (117) does not sit on top of the first weight plate (67), push the head plate down, insert the selector pin (72) and perform several repetitions at the station. This will relax the cable system and prevent the head plate from lifting up.
- C. If after completing step B. the head plate still does not sit on top of the first weight plate or if there is excess slack in the cable system, adjust the threaded end of the cable accordingly and retighten the jam nut.

Shroud Assembly Instructions

Use this procedure to assemble the shrouds of the ParaBody 950ST

- A. Securely assemble the pec station shroud (51) to the pec guide rod support (43) and the base (15) using four 3/8 x 1" black button head cap screws (59).
(Note: The pec station shroud has no labels.)

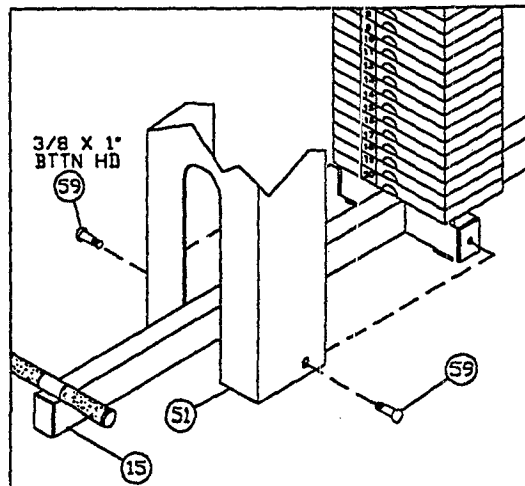

- B. Securely assemble the press station shroud (53) to the press guide rod support (24) and the press weight stack base (1) using three 3/8 x 1" black button head cap screws (59) and one 3/8 x 1" bolt (97). (Note: The press station shroud has the press exercise diagram.)

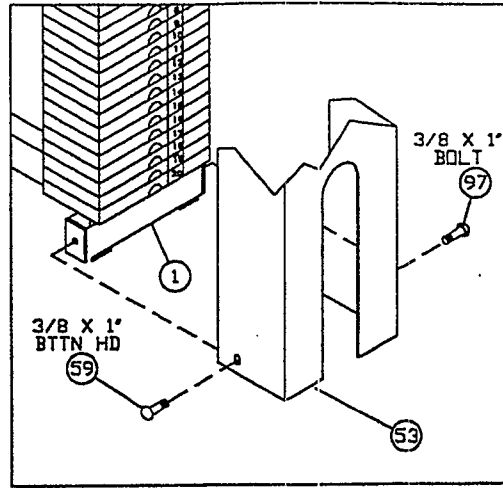

- C. Securely assemble the leg station shroud (52) to the leg guide rod support (25) and the leg weight stack base (18) using four 3/8 x 1" black button head cap screws (59). (Note: The leg station shroud has the leg exercise diagram.)

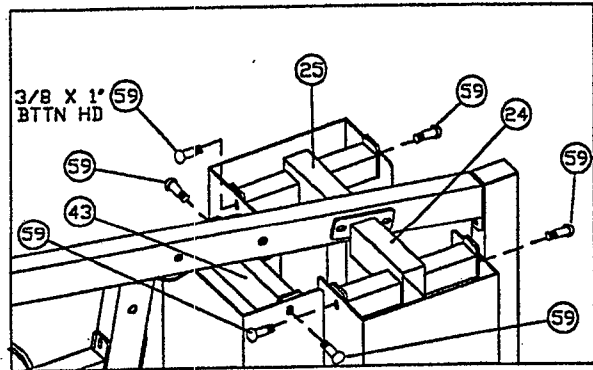
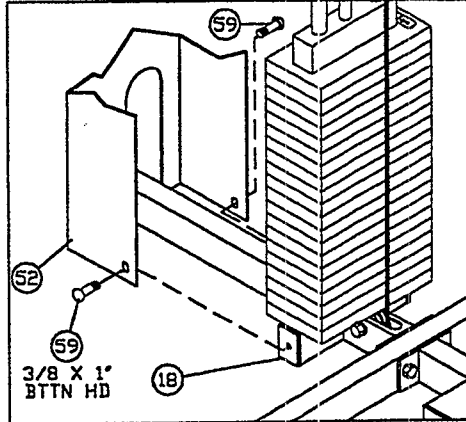

THIS CONCLUDES THE ASSEMBLY OF THE PARABODY 950 ST GYM.
Please refer to the exercise diagrams for proper use of this product.

Free Manuals Download Website

<http://myh66.com>

<http://usermanuals.us>

<http://www.somanuals.com>

<http://www.4manuals.cc>

<http://www.manual-lib.com>

<http://www.404manual.com>

<http://www.luxmanual.com>

<http://aubethermostatmanual.com>

Golf course search by state

<http://golfingnear.com>

Email search by domain

<http://emailbydomain.com>

Auto manuals search

<http://auto.somanuals.com>

TV manuals search

<http://tv.somanuals.com>