

Replacement Fan Tray Assembly for the 8820 Broadband Loop Carrier Model 8820-S3-900

Installation Instructions

Document Number 8820-A2-GZ48-00

January 2005

Fan Tray Assembly

The fan tray assembly is a dedicated cooling device installed in the chassis of the 8820 Broadband Loop Carrier (BLC) to provide forced-air cooling of the chassis. The fans, located at the top of the BLC chassis, draw cooling air upwards from the bottom of the chassis, through the circuit cards or card cage, forcing the air out the opening, located at the top rear of the chassis.

The fan tray assembly consists of six fans, a metal bracket, and a printed wiring board (PWB) with a press-fit connector and five status LEDs. Each fan provides a sense wire that indicates the status of the fan. The sense wires are connected to the backplane via the fan tray's PWB and its connector.

The rated airflow is 900 cfm (based on 6 fans at 150 cfm each) at zero back pressure.

The fan tray is powered by -48 or -60 VDC from the backplane of the 8820 BLC. Nominal power consumption is less than 100 watts.

An LED is on the fan tray so that if a fan failure occurs, a signal is sent to the SCP card or MCP card and the yellow Fan ALARM LED on the chassis lights. Removal of the fan tray also causes the SCP card or MCP card to sense an alarm.

The fan tray assembly weighs 10 lbs (22 kg). It is secured by two fan-locking brackets located on the right and left front of the assembly.

Removing the Existing Fan Tray Assembly

You will need a Phillips screwdriver to remove the vent cover and fan tray.

► Procedure

To remove the existing fan tray assembly:

1. Remove three screws from the fan cover plate, and then remove the cover plate from the chassis, taking care not to damage the LED protruding through the cover plate.

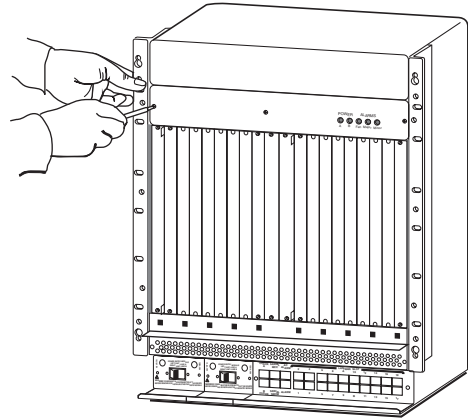

00-16792

2. Loosen (but do not remove) the two screws on each locking bracket, and use them to slide both locking brackets toward the middle of the front panel until the ends clear the slots in the side plates.

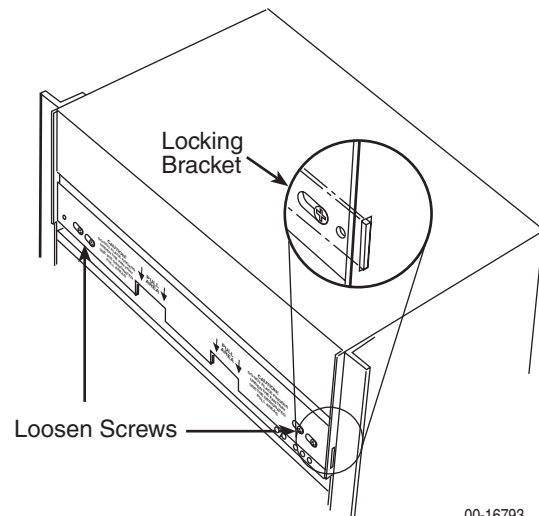

00-16793

NOTE:

There are two cutouts in the front face of the fan tray labeled PULL AREA. This is where you place your fingers to pull the fan tray out of the chassis.

▲ WARNING:

A MECHANICAL HAZARD EXISTS DUE TO ROTATING FAN BLADES. KEEP HANDS AND FINGERS AWAY FROM FAN BLADES DURING REMOVAL OF FAN TRAY. USE ONLY THE DESIGNATED PULL AREAS TO DISENGAGE THE FAN TRAY.

⚠ ATTENTION:

UN RISQUE MÉCANIQUE EXISTE EN RAISON DE LA ROTATION DES PALES DU VENTILATEUR. GARDER LES MAINS ET LES DOIGTS LOIN DES PALES DU VENTILATEUR PENDANT LE DEMONTAGE DU CACHE DU VENTILATEUR. UTILISER UNIQUEMENT LES ZONES INDIQUÉES DE TRACTION POUR DÉMONTÉ LE CACHE DU VENTILATEUR.

⚠ VORSICHT:

VERLETZUNGSGEFAHR AUFGRUND ROTIERENDER VENTILATORFLÜGEL. BEI ABNAHME DER VENTILATOR-ABDECKUNG ODER AUSBAU DES VENTILATORS NICHT IN DEN ROTATIONSBEREICH DES VENTILATORS GREIFEN. BEI AUSBAU DES VENTILATORS FESTE UND BEWEGLICHE TEILE NUR AN DEN GEKENNZEICHNETEN STELLEN BERÜHREN.

3. Using both hands, place your index fingers in the PULL AREA openings and pull forward about an inch to disconnect the fan tray's connector from the backplane. The spinning fan blades will now be visible.

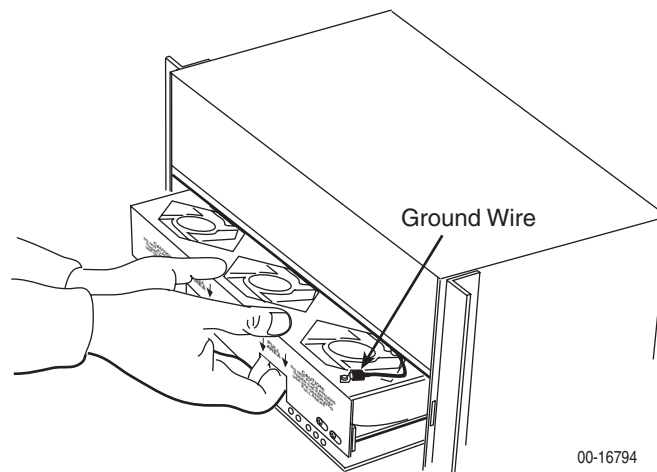

4. **Wait until the fan blades stop spinning** (which should be less than a minute). Disconnect the ground wire from the quick connect terminal on the chassis.
5. Remove the fan tray from the chassis.

Installing a Replacement Fan Tray Assembly

You will need a Phillips screwdriver to install a replacement fan tray.

► Procedure

To install a replacement fan tray:

1. Hold the replacement fan tray horizontally and guide its tabs into the two card guides located inside the right and left side plates.

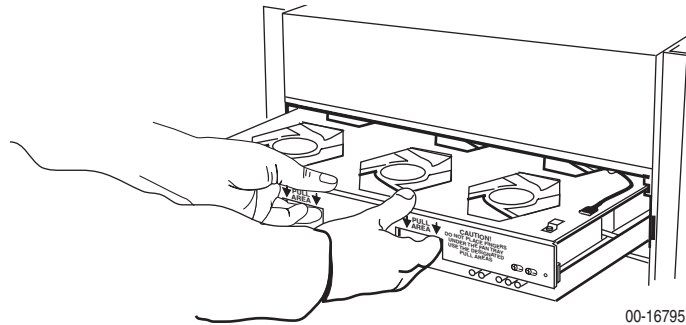

▲ WARNING:

If the chassis is powered on, when the fan tray's connector is seated in the backplane, the fan blades start spinning. Proper care should be taken to prevent contact with the spinning fan blades.

2. Pressing on the front of the fan tray bracket, push the fan tray half way in and attach the ground wire. Then, fully seat the fan tray.

NOTE:

When the fan tray is running at full speed the Fan ALARM LED will go out, indicating that all fans are operating properly.

3. Loosen the two screws slightly on each locking bracket and slide the locking brackets outward until they engage the slots located on the left and right side plates.

NOTE:

When properly extended or locked, the brackets should be extended into the slots on the side plates and a threaded insert on the locking bracket should be aligned with (and visible through) the two outermost holes of the fan tray.

4. Tighten the two screws on each bracket, making sure that the bracket's inserts stay aligned with the holes in the fan tray.

-
5. Replace the fan cover plate, aligning the five holes at the bottom with the five status LEDs.
 6. Replace and tighten the three screws removed earlier to secure the fan cover plate to the chassis.

Warranty, Sales, Service, and Training Information

Contact your local sales representative, service representative, or distributor directly for any help needed. For additional information concerning warranty, sales, service, repair, installation, documentation, training, distributor locations, or Paradyne worldwide office locations, use one of the following methods:

- **Internet:** Visit the Paradyne World Wide Web site at www.paradyne.com. (Be sure to register your warranty at www.paradyne.com/warranty)
- **Telephone:** Call our automated system to receive current information by fax or to speak with a company representative.
 - Within the U.S.A., call 1-800-870-2221
 - Outside the U.S.A., call 1-727-530-2340

Product Documentation Online

Complete documentation for Paradyne products is available at www.paradyne.com. Select *Support* → *Technical Manuals*.

To order a paper copy of a Paradyne document, or to speak with a sales representative, please call 1-727-530-2000.



8820-A2-GZ48-00

Free Manuals Download Website

<http://myh66.com>

<http://usermanuals.us>

<http://www.somanuals.com>

<http://www.4manuals.cc>

<http://www.manual-lib.com>

<http://www.404manual.com>

<http://www.luxmanual.com>

<http://aubethermostatmanual.com>

Golf course search by state

<http://golfingnear.com>

Email search by domain

<http://emailbydomain.com>

Auto manuals search

<http://auto.somanuals.com>

TV manuals search

<http://tv.somanuals.com>