

Linear actuators

HLE with timing belt drive

HLEZ with rack-and-pinion drive

Catalogue: 192-510011N7

Version 7 / May 1999

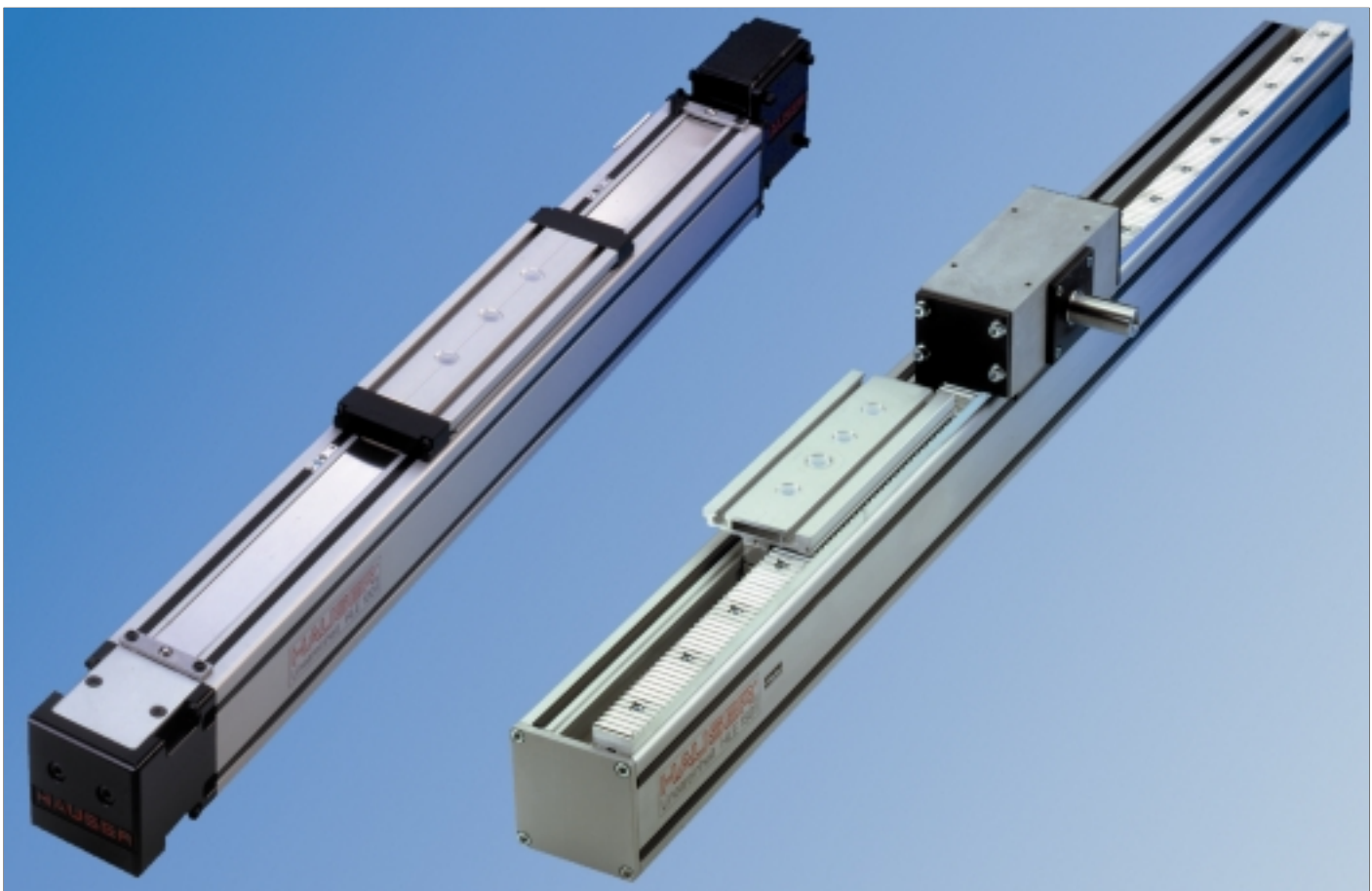

HLE linear actuators with timing belt drive - for guiding, transporting and positioning -

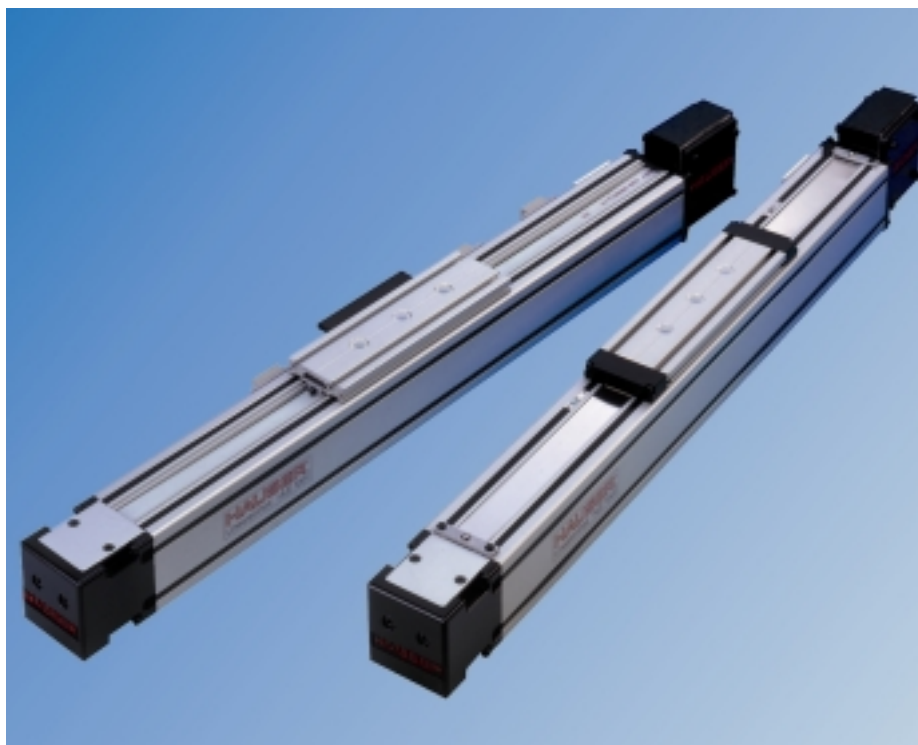

Contents:

The HLE - a proven technology.....	4
Construction of the HLE.....	5
Technical data.....	6
Dimensional drawings.....	8
HLE 80.....	8
HLE100.....	10
HLE 150.....	12
Idler unit.....	14
Carriage with bar.....	14
Order code.....	15
HLEZ linear actuators with rack-and-pinion drive.....	17
Mechanical accessories.....	25
Assembly angle plate.....	25
Clamping profile.....	26
T-nuts and bolts.....	26
Link shaft bearing.....	27
External buffer stop.....	27
Cable carrier.....	28
Longitudinal flange connection set....	30
Attachment of position sensors.....	31
Tripping plate.....	32
Mechanical limit switch.....	33
Electrical limit switch.....	33
Distribution box.....	34
Other accessories and software.....	34

The dynamic linear unit

for guiding, transporting and positioning, even over long distances, offers:

- ◆ High speeds in practical applications of up to 7 m/s
- ◆ Up to 108 Nm permitted driving torque
- ◆ Long travel distances, up to 20 m
- ◆ High load capacity, horizontal up to 1000 kg /, vertical up to 300 kg
- ◆ Repeatability, up to ± 0.05 mm
- ◆ High mechanical efficiency of 95 %
- ◆ Three profile sizes: HLE80, HLE100 and HLE150, can be combined in a modular system
- ◆ Simple, rapid installation and start-up

Typical fields of application

as part of advanced, cost-effective construction of machines and handling systems:

- ◆ **Materials handling** e.g. palletization, feeding, withdrawal
- ◆ **Textile machinery building** e.g. cross-cutting, slitting and stacking, quilting, seam stitching
- ◆ **Process engineering** e.g. painting, coating, bonding
- ◆ **Warehouse technology** e.g. picking, storage
- ◆ **Construction** e.g. formwork, placing reinforcing steel
- ◆ **Clean room technology** e.g. wafer transport, wafer coating
- ◆ **Machine tool building** e.g. loading with workpiece, tool changing
- ◆ **Testing technology** e.g. guiding ultrasonic sensors

Proven technology

proven in numerous applications, offers the following advantages:

- ◆ Low-friction running guaranteed:
 - ◆ Low particle generation (clean room suitability to class 10)
 - ◆ low wear
 - ◆ zero maintenance
 - ◆ quiet running
 - ◆ high efficiency and
 - ◆ long service life
- ◆ High dynamic performance due to low-mass, play-free wheels
- ◆ Simplified inspection with long inspection intervals.
- ◆ Longitudinal grooves integrated on all sides of the profile for mounting attachments or for use as a cable duct
- ◆ Timing belts can be replaced without dismantling load attachment plate.
- ◆ Flexible installation options provided by longitudinal grooves in the load attachment plate.

HLE – Linear actuators with timing belt drive

The HLE - a proven technology

The universal one

The HLE linear actuator offers an appropriate solution for all motion tasks. It is ideal for use as a single axis, or as a component in a multiple axis system. It has been developed for rapid linear movements over long stroke distances. The HLE provides a simple machine and system element and can be used without the need for any specialised knowledge. Installation and starting up only requires a small amount of effort from the user. The HLE is supplied in many different configurations with numerous options and many accessories.

Our experience

You can have confidence in our experience and skill because over 6000 axes are already in use throughout the world - be it in automatic textile equipment, handling systems, packaging machines, automatic painting and binding equipment ...etc.

The HLE can be found in a wide range of applications: in clean rooms, in the food industry, production plants in the chemical industry or in the manufacture of prefabricated concrete components.

We work together with a wide range of different industrial sectors including the automobile industry, machine tool manufacturers, microelectronics manufacturers - and hopefully soon with you ...

Examples/applications

- ◆ Mercedes Benz, Sindelfingen, Germany: supporting cockpit parts in the S-class
- ◆ IBM, Böblingen, Germany: wafer transport in chip production
- ◆ Bosch-Siemens Hausgeräte GmbH, Traunreut, Germany: handling cookers
- ◆ SEL, Stuttgart, Germany: picking electronic components
- ◆ Bayer, Bitterfeld: palletising folding cartons (flatpack boxes) for pharmaceuticals
- ◆ LT Engineering, Switzerland: shelf-picking unit for small parts stores
- ◆ Braas, Steinfeld: handling roof tiles
- ◆ Philips, Holland: handling screen masks
- ◆ Weckenmann, Dormettingen: setting shell profiles in the concrete branch.

The HLE drive principle

The HLE consists of an extruded, self-supporting aluminium profile, inside which a backlash-free wheeled carriage is moved by a timing belt.

The steel cord tensile strands integrated into the belt provide the necessary stiffness and effectively prevent belt stretching.

Special pulleys ensure play-free drive, ensuring high repeatability even with long travel paths and high speeds.

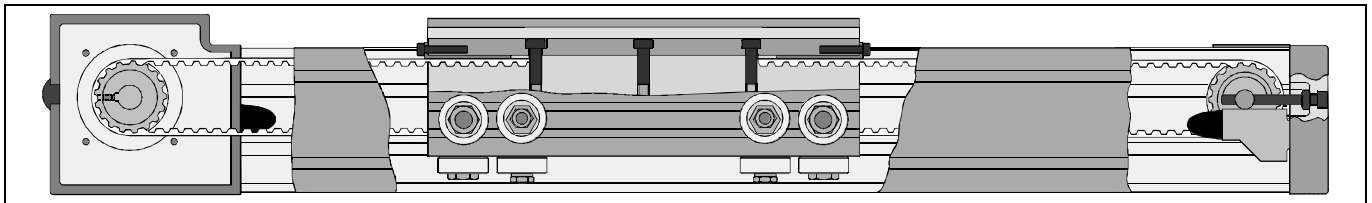

Optional steel strip cover

A totally new steel strip cover concept applies fully to the HLE-design. It reliably

protects the timing belt, wheels and the bearing surface of the profile

against dirt (protection class IP30).

The T-grooves of the load attachment plate and the basic HLE profile are suitable for T-nuts in accordance with DIN508 and T-bolt in accordance with DIN 787 (T-nuts and bolts: refer to page 26)

Steel plate integrated in the carriage plate serves as switching plate for home & limit sensors.

Protective caps ensure that no dust enters the interior of the HLE

A spring-loaded felt insert reliably keeps dirt away

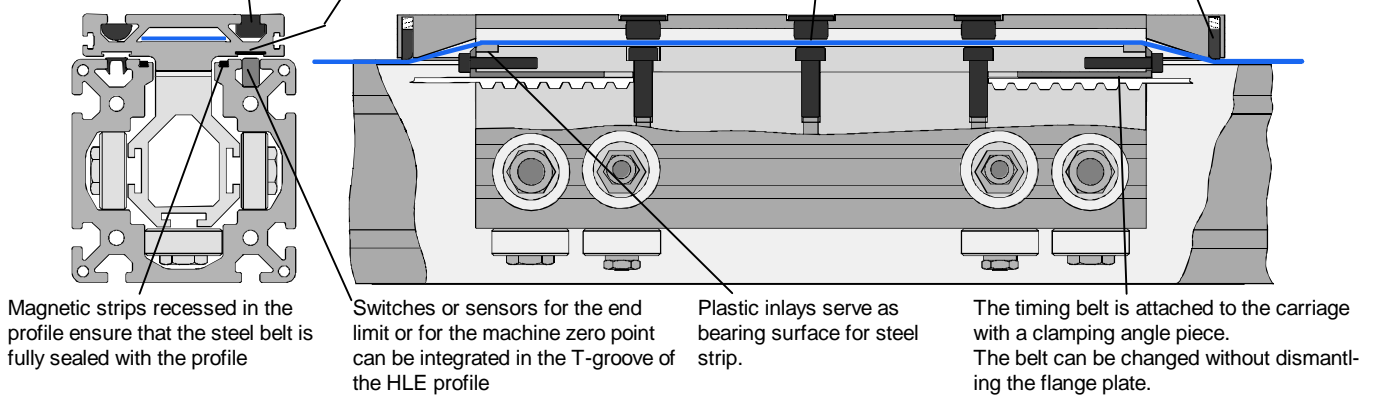

Magnetic strips recessed in the profile ensure that the steel belt is fully sealed with the profile

Switches or sensors for the end limit or for the machine zero point can be integrated in the T-groove of the HLE profile

Plastic inlays serve as bearing surface for steel strip.

The timing belt is attached to the carriage with a clamping angle piece. The belt can be changed without dismantling the flange plate.

Construction of the HLE

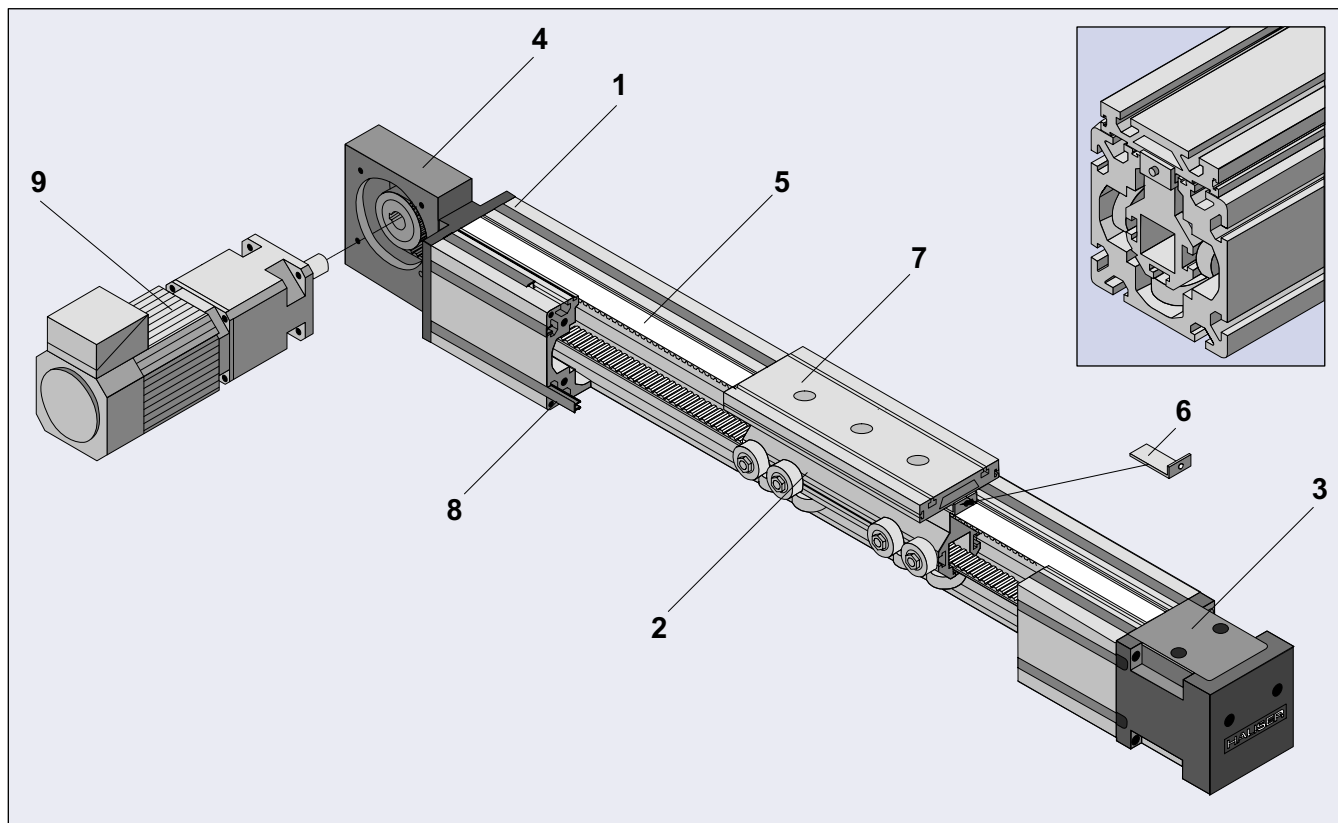

The profile (1)

Light, compact and self-supporting aluminium profile construction. Available in the following cross-sections:

80x80 mm	(HLE80)
100x100 mm	(HLE100)
150x150 mm	(HLE150)

All profiles feature a total of eight longitudinal clamping grooves for the attachment of additional mechanical components and for the connection of several HLE units. These grooves also serve as attachment and mounting points for initiators and mechanical switches.

Together with the HAUSER cover profiles (8), these can be used as cable ducts.

The carriage (2)

Light, rigid carriages with plastic rollers mounted on roller bearings and eccentric axles for play-free carriage settings on all sides. Overall, this results in high mechanical efficiency and virtually wear-free operation. The carriage can be supplied in two lengths, either standard or extended.

We can also produce special carriages for customised applications.

The tensioning station (3)

An easily maintained and assembly-friendly tensioning station for setting the tension required for the timing belt and its orientation (parallelism of pulleys).

The drive station (4)

Robust cast casing with standard flange. Many gearboxes can be directly flange-mounted (for bore pattern, refer to dimensions). On request, this can be supplied with the drive shaft on the right, on the left or on both sides.

The timing belt (5)

The timing belt has no play and is reinforced by integral steel wires, thereby ensuring maximum travel speeds and repeatability.

Clamping of timing belt (6)

The timing belt clamping angle guarantees a secure connection between the timing belt and the carriage.

The clamping system allows the timing belt to be replaced without the load attachment plate having to be dismantled. This means that attachments do not normally need to be removed.

The load attachment plate (7)

- ◆ The longitudinal grooves integrated on the top of the plate offer many options for the assembly of attachments.

When used in conjunction with the clamping profile (page 26) this allows for simple incorporation in a multi-axis system.

- ◆ Simple and adjustable attachment of operating cams or switch lugs by means of longitudinal grooves on the sides and on the underside of the plate.
- ◆ Height and bolt points are unaffected when the steel strip cover is attached at a later date.

Special designs are also available on request.

The optional drive motor (9)

Parker servo motor with resolver and an appropriate planetary gearbox form an optimum drive for dynamic and accurate applications. When used together with the COMPAX compact servo controller, the HLE becomes a complete, ready-to-run automation system for single and multi-axis travel and continuous path controls.

The V2A version (option V)

Minimum particle emissions and high levels of resistance to water and various cleaning agents make the V2A version the number one choice for use in clean rooms or the food industry.

The steel components are made of V2A material and the rollers and pulley mountings are fitted with corrosion-resistant bearings.

HLE – Linear actuators with timing belt drive

Technical data

HLE size	Unit	80		100		150	
		Standard	Steel strip cover	Standard	Steel strip cover	Standard	Steel strip cover

Weight and moment of inertia

Weight of basic unit without stroke							
HLE with standard carriage S	kg	7.1	7.9	11.5	12.7	28.6	31.2
HLE with extended carriage E	kg	8.4	9.9	14.6	15.8	35.9	38.5
Weight of standard carriage + load attachment plate S	kg	1.5	1.7	2.5	2.8	6.7	7.3
Weight of extended carriage + load attachment plate E	kg	2.5	2.8	4.1	4.4	10.9	11.5
Weight per meter of additional length	kg/m	6.4	6.4	9.9	10.0	21.0	21.1
Moment of inertia related to the drive shaft							
Standard carriage S	kgcm ²	18.1	20.3	22.3	24.6	114.0	123.3
Extended carriage E	kgcm ²	27.5	29.7	34.1	36.4	174.4	183.6

Travel paths and speeds

Maximum travel speed ¹	m/s	5.0		5.0		5.0	
Maximum acceleration ¹	m/s ²	10.0		10.0		10.0	
Maximum travel path, standard carriage S/T ² with one profile bar	mm	5350	5260	6300	6210	9150	9060
Maximum travel path, extended carriage E/F ² with one profile bar	mm	5200	5110	6150	6060	9000	8910

Geometrical data

Cross-section	mm x mm	80 x 80		100 x 100		150 x 150	
Moment of inertia I _x	cm ⁴	152		383		1940	
Moment of inertia I _y	cm ⁴	177		431		2147	
Moment of inertia I _t	cm ⁴	24		117		391	
Modulus of elasticity	N/mm ²	0.72*10 ⁵					

Pulley data, torques and forces

Travel distance per revolution	mm/rev	190		170		240	
Pulley diameter	mm	60.479		54.113		76.394	
Nominal drive torque	Nm	17.5		15.7		51.4	
Maximum drive torque ³	Nm	32		40		108	
Nominal belt traction (effective load)	N	580		580		1350	
Max. belt traction ³ (effective load)	N	1058		1478		2827	
Repeatability ⁴	mm	±0.2		±0.2		±0.2	

Please contact HAUSER in the event of the following deviations from the standard technical data:

¹ Travel speeds over 5m/s and acceleration over 10m/s².

² Longitudinal flange connection possible for longer travel distances. This does lead to limitations with regard to: maximum permitted load, drive torque, speed, acceleration and repeatability (refer to page 30)

³ Increased timing belt tension required.

⁴ Repeatability up to ± 0.05 mm



Technical data, issued 06/99, safety factor taken into consideration S=1. Data applies for a temperature range of between -10°C and +40°C

HLE – Linear actuators with timing belt drive

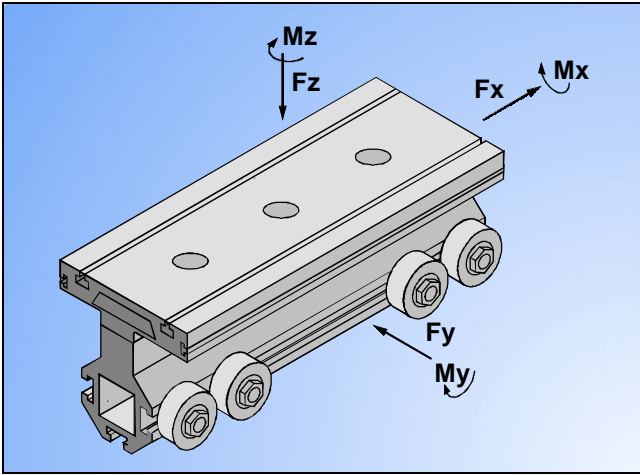

The forces and torques the carriage and the timing belt are capable of transferring are speed-dependent.

The curves shown in the graphs apply to a standard carriage (S/T).

With the extended carriage (E/F), all the values apart from F_x (load-bearing capacity of timing belt) can be doubled if the load is applied equally to both halves of the carriage or distributed uniformly along its entire length.

The curves show the maximum load-bearing capacity of a carriage in one direction of force or torque. If several loads are applied in different directions, the values given by the curves **must be derated**, i.e. the load or speed should be reduced if necessary.

For precise carriage dimensioning, our software "DimAxes" is available (Refer to "Other accessories and software", page 34).

F_x [N] (load-bearing capacity of timing belt)

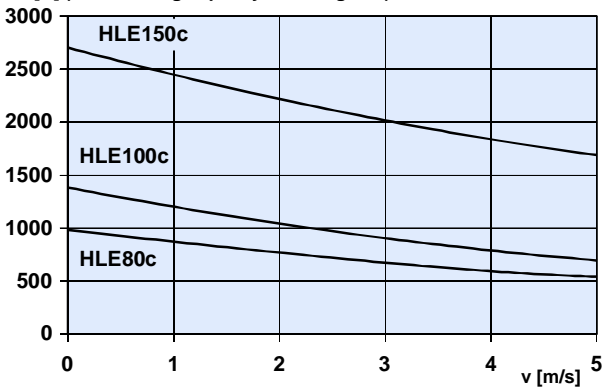

M_x [Nm]

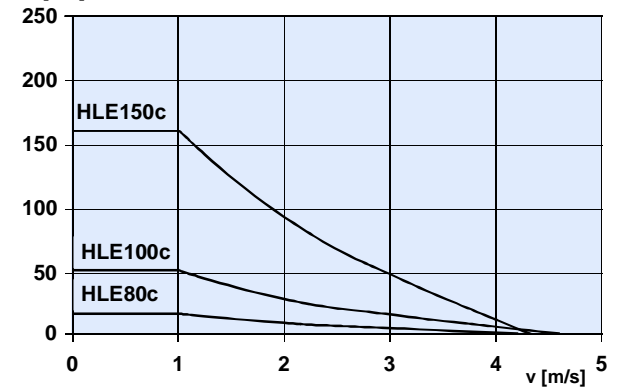

F_y [N]

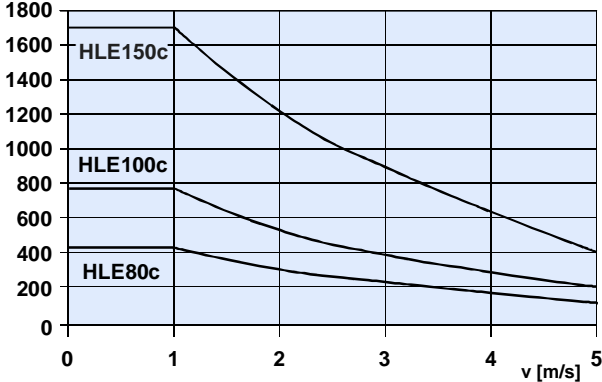

M_y [Nm]

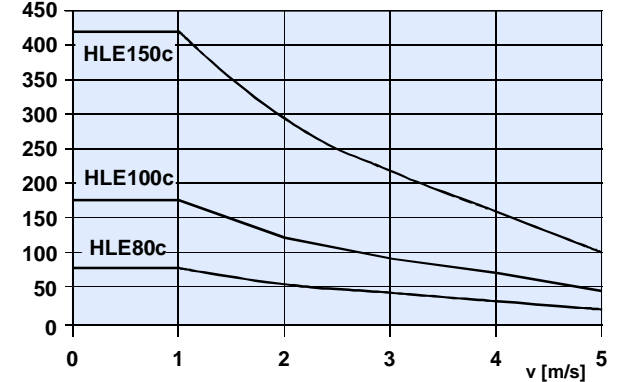

F_z [N]

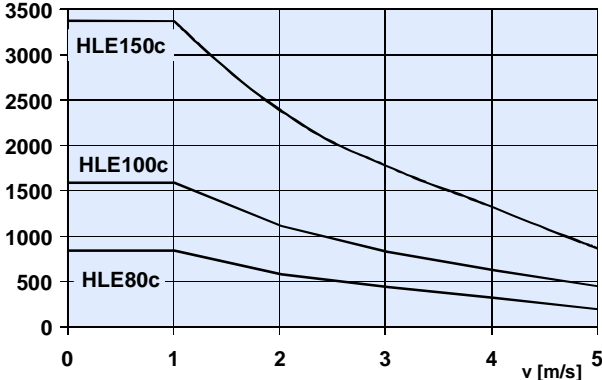

M_z [Nm]

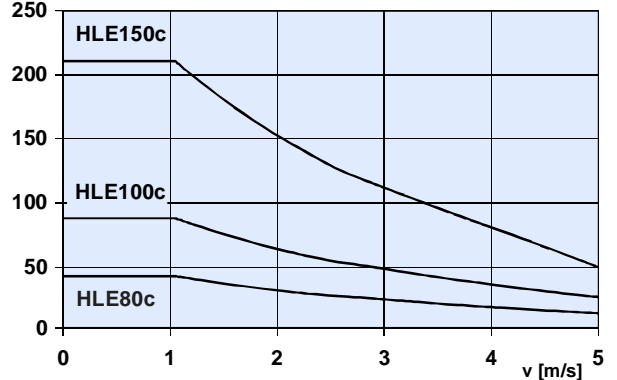

Dimensional drawings

HLE 80 single axis

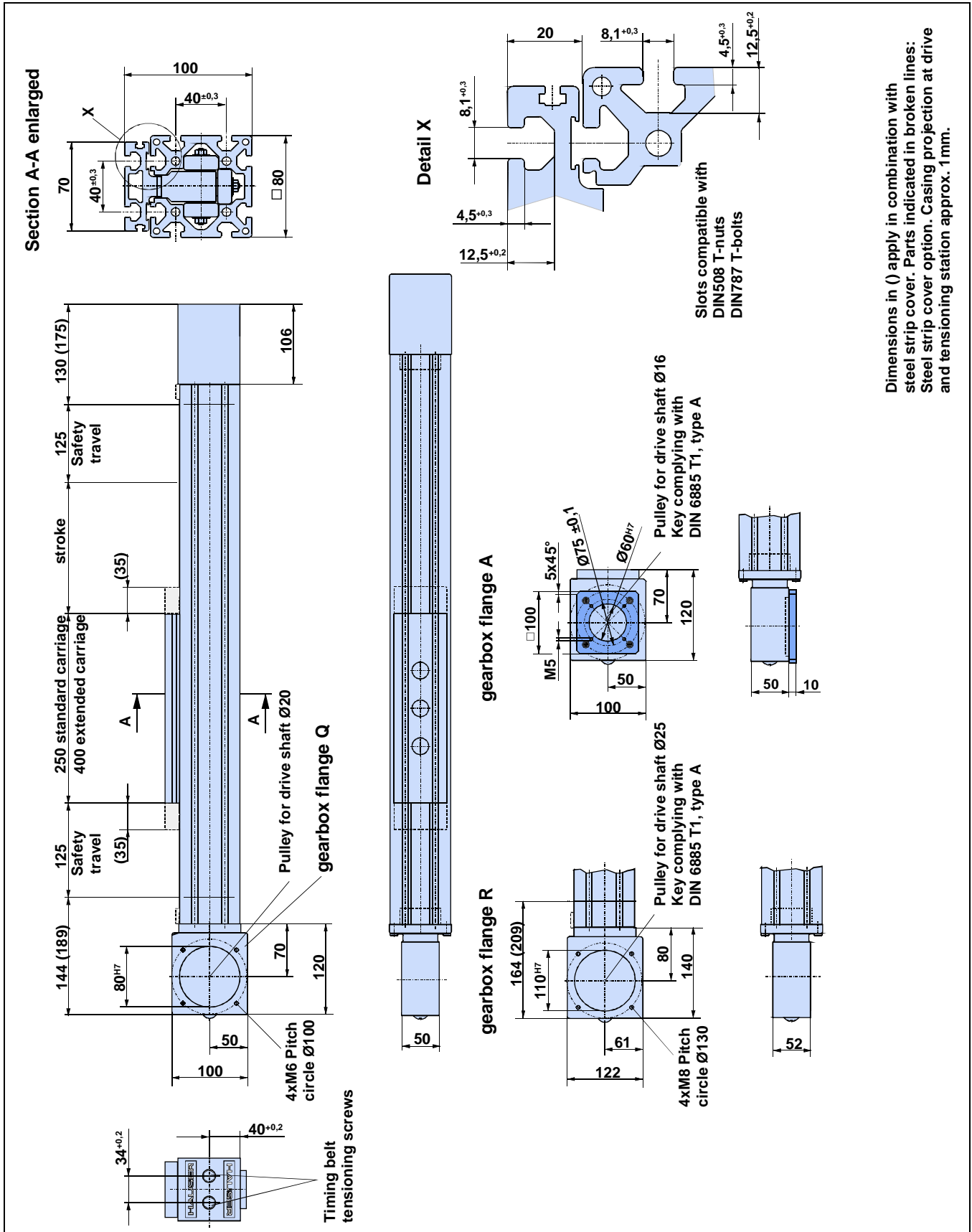

HLE – Linear actuators with timing belt drive

HLE80 drive housing with drive shafts

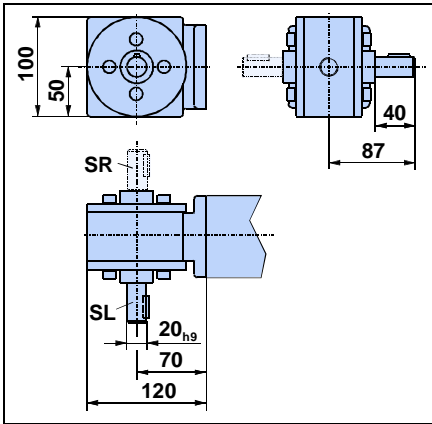

SL: shaft on left
SR: shaft on right

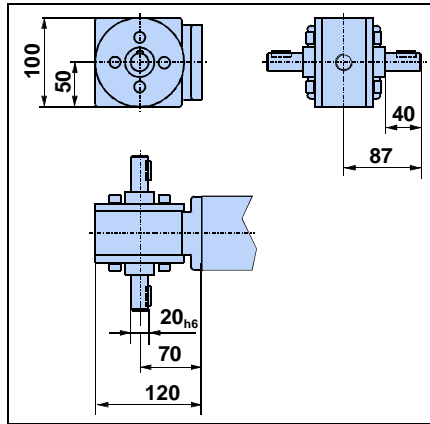

SB: shafts on both sides

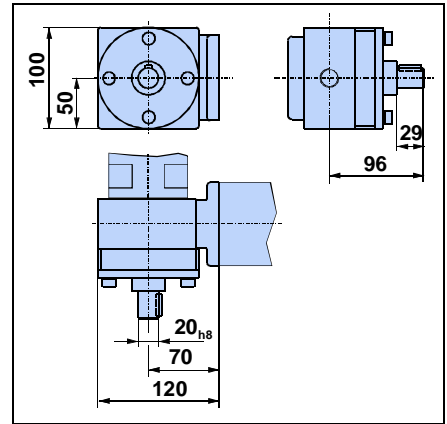

RL: gearbox on right and shaft on left
LR: gearbox on left and shaft on right

HLE 80 dual axis with gearbox flange Q

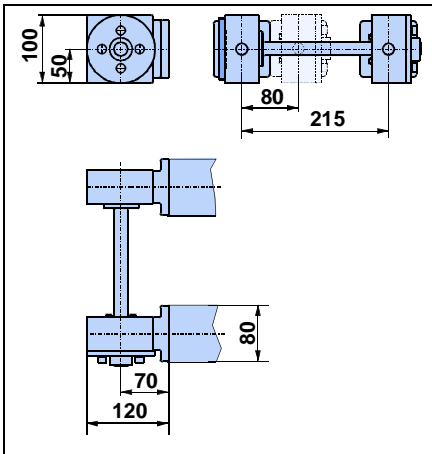

Centre distance A between 80-215 mm

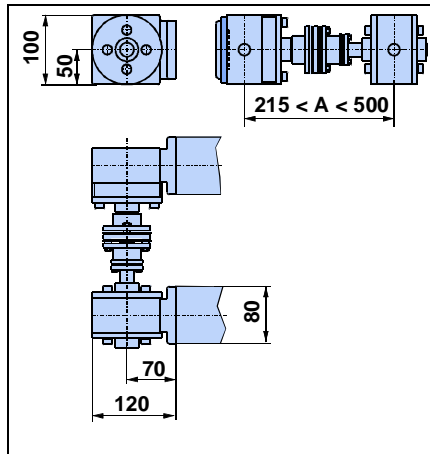

Centre distance A between 215-500 mm

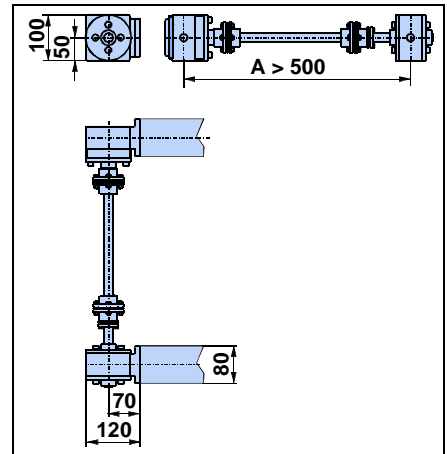

Centre distance A greater than 500 mm

HLE 80 dual axis with gearbox flange R

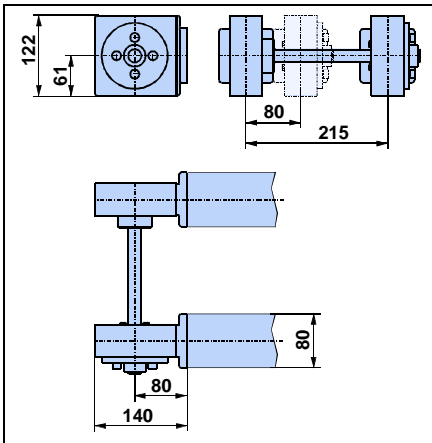

Centre distance A between 80-215 mm

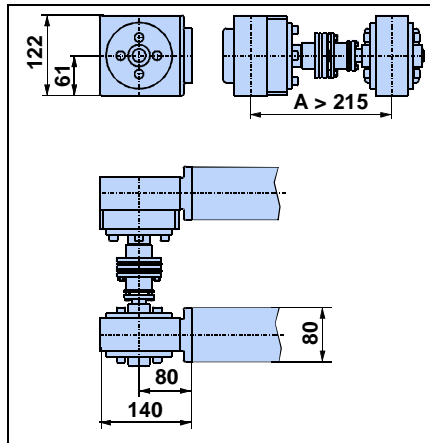

Centre distance A between 215-500 mm

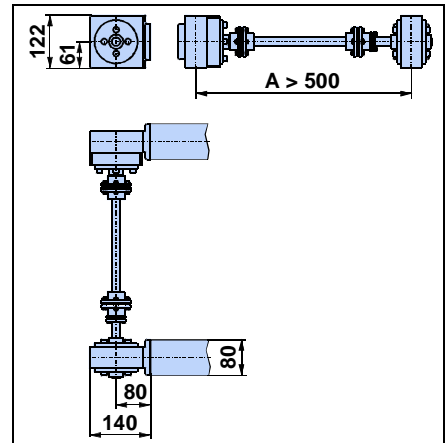

Centre distance A greater than 500 mm

HLE – Linear actuators with timing belt drive

HLE100 single axis

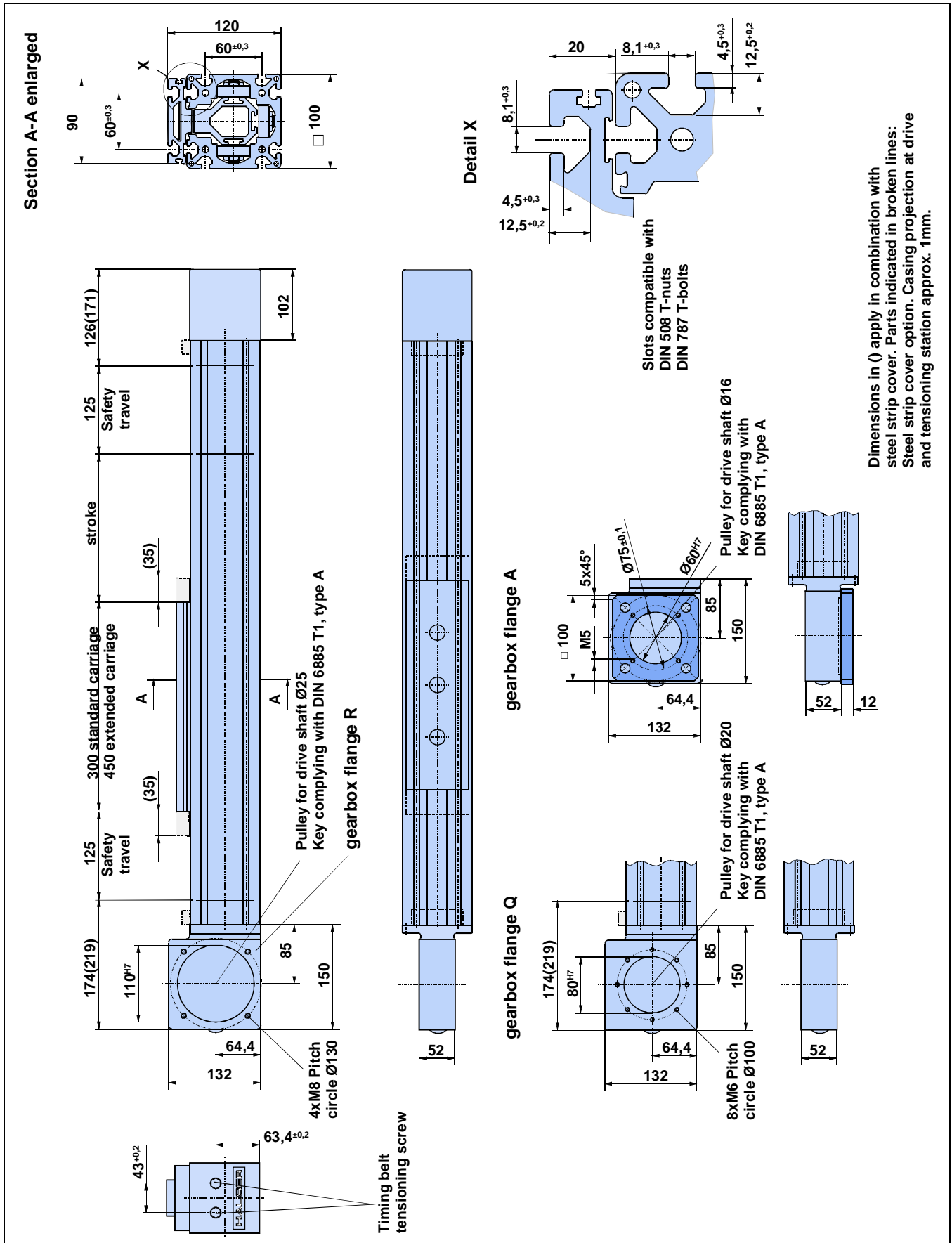

HLE – Linear actuators with timing belt drive

HLE100 drive housing with drive shafts

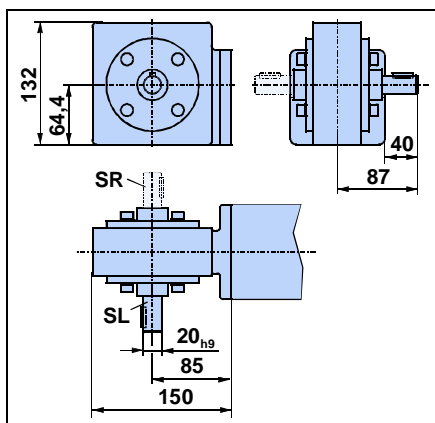

SL: shaft on left
SR: shaft on right

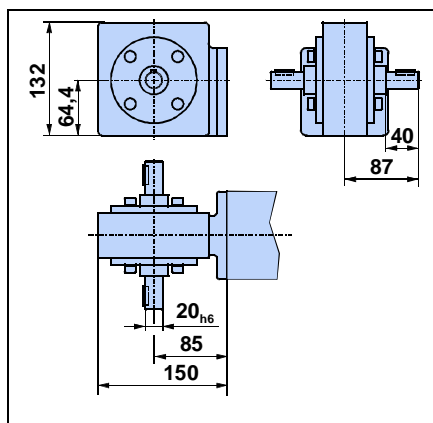

SB: shaft on both sides

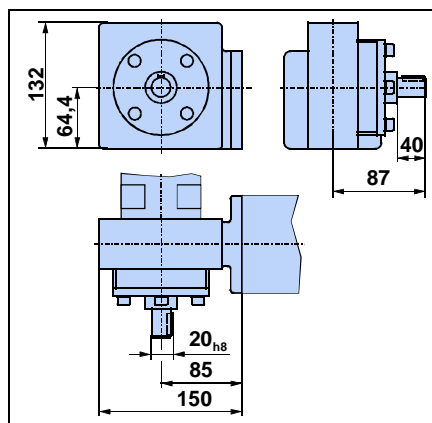

RL: gearbox on right and shaft on left
LR: gearbox on left and shaft on right

HLE 100 dual axis with gearbox flanges Q and R

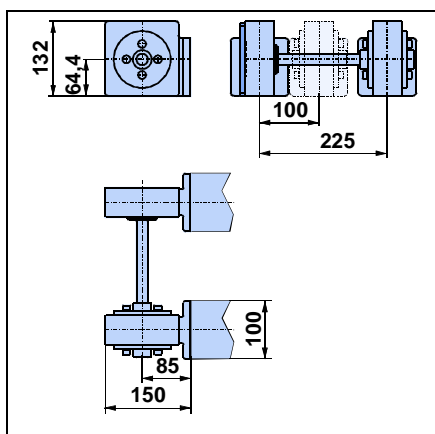

Centre distance A between 100-225 mm

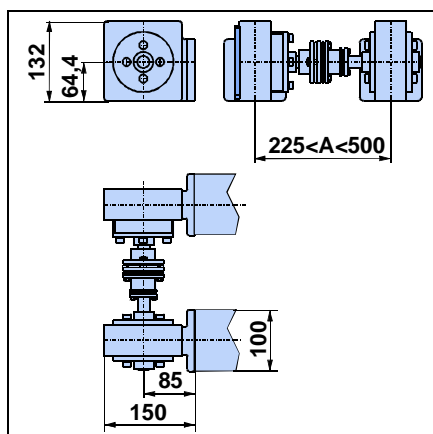

Centre distance A between 225-500 mm

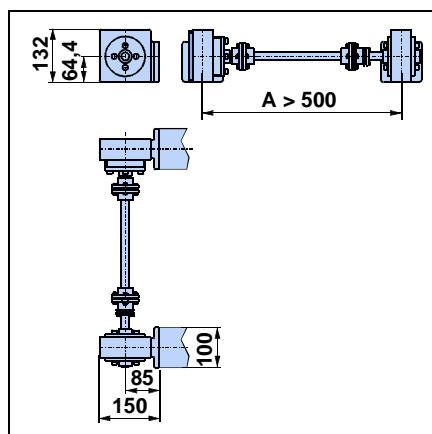

Centre distance A greater than 500 mm

HLE – Linear actuators with timing belt drive

HLE 150 single axis

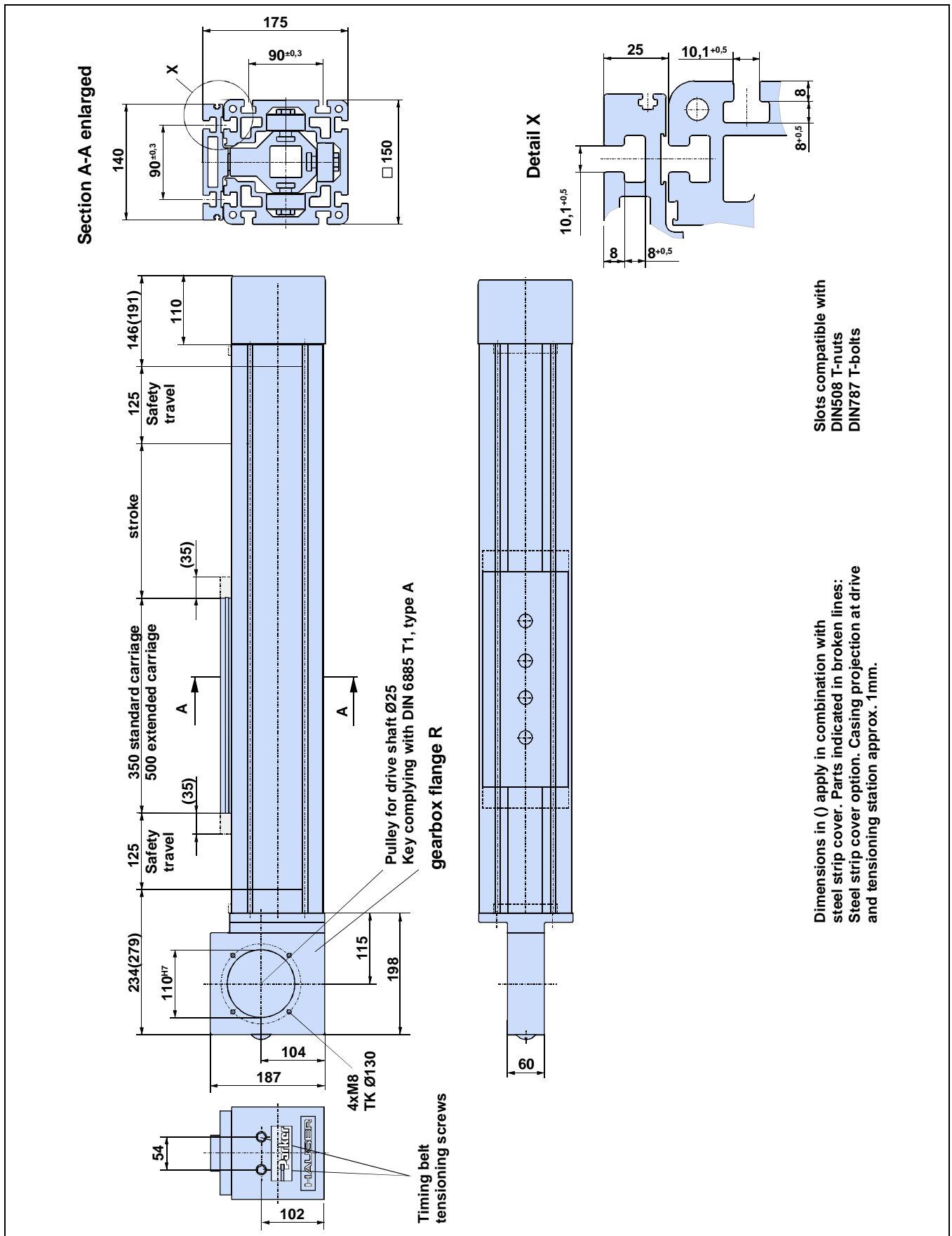

HLE – Linear actuators with timing belt drive

HLE150 drive housing with drive shafts

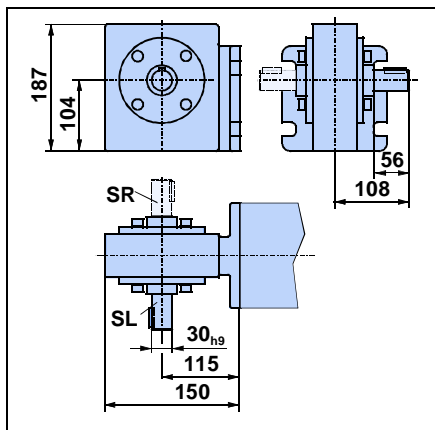

SL: shaft on left
SR: shaft on right

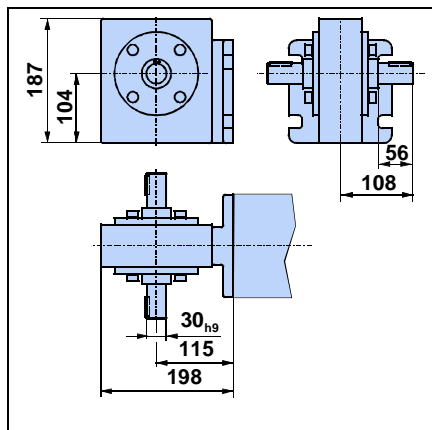

SB: shaft on both sides

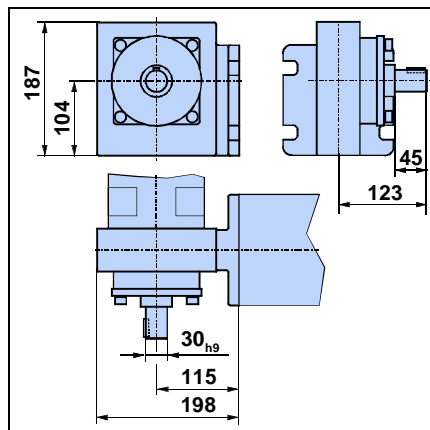

RL: gearbox on right and shaft on left
LR: gearbox on left and shaft on right

HLE 150 – dual axis with gearbox flange R

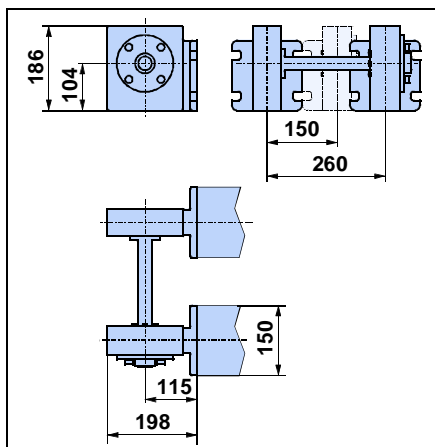

Centre distance A between 150-260 mm

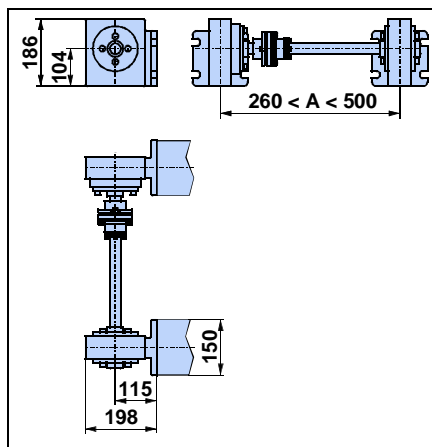

Centre distance A between 260-500 mm

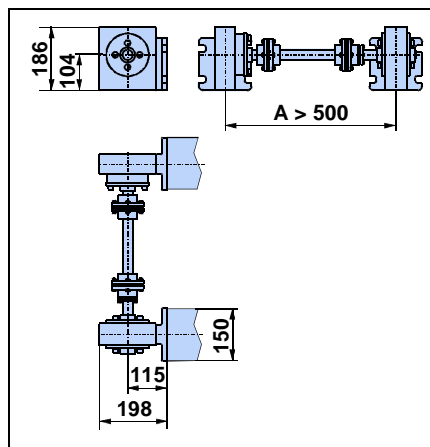

Centre distance A greater than 500 mm

HLE – Linear actuators with timing belt drive

Idler unit

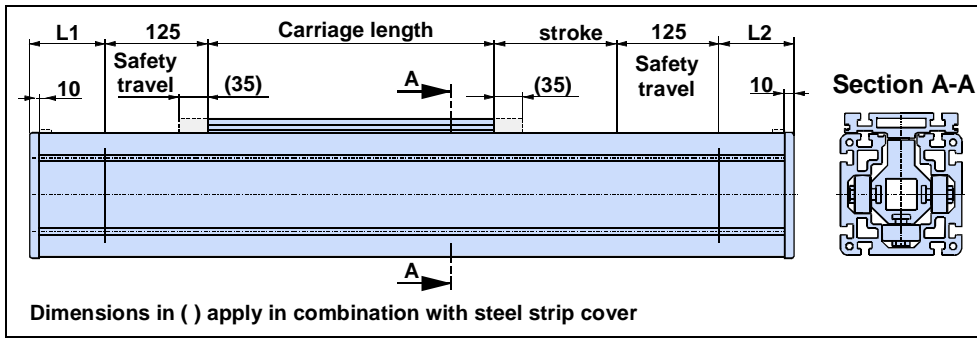

The HLE is also available as a non-driven, idler unit. In this case it acts as a guide only. The profile cross-section and carriage dimensions correspond to those for the driven axes. Please take dimensions L1 and L2 from the following table:

Dimensions	Unit	HLE80		HLE100		HLE150	
		L1	L2	L1	L2	L1	L2
Standard	mm	34	34	34	34	46	46
Steel strip cover	mm	79	79	79	79	91	91

Carriage with bar (type T or F without load attachment plate)

When ordering an HLE without load attachment plate, the bar is used as a replacement for the belt clamp. The threads in the carriage are accessible through holes in the bar for mounting your own attachments. Diagrams show the location of tapped holes for load attachment.

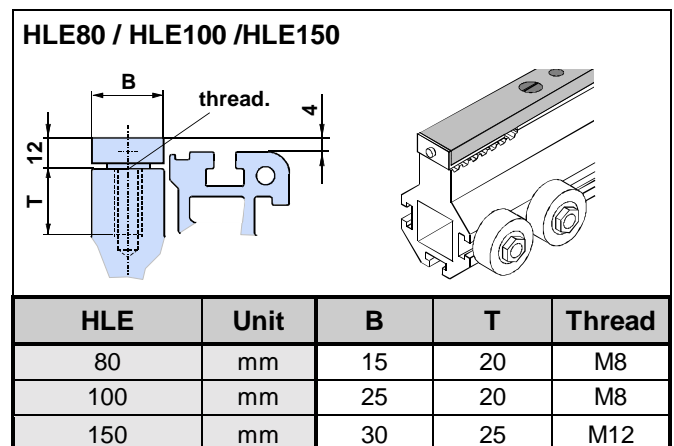
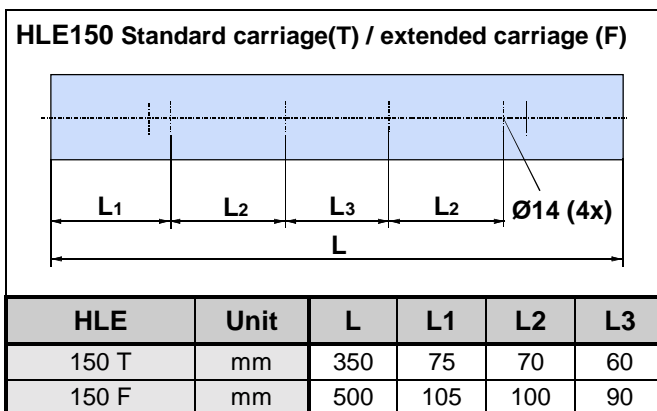
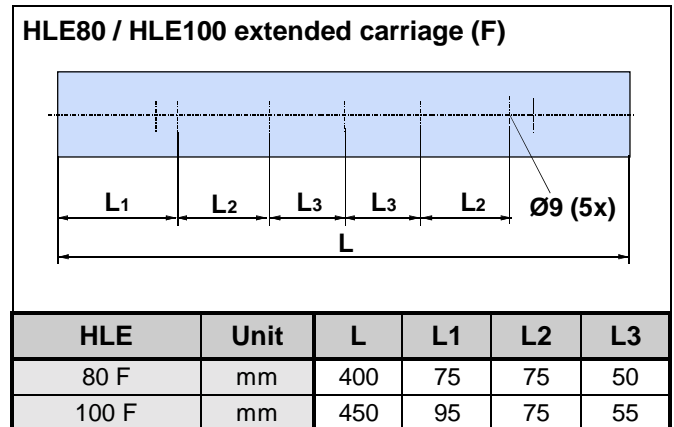
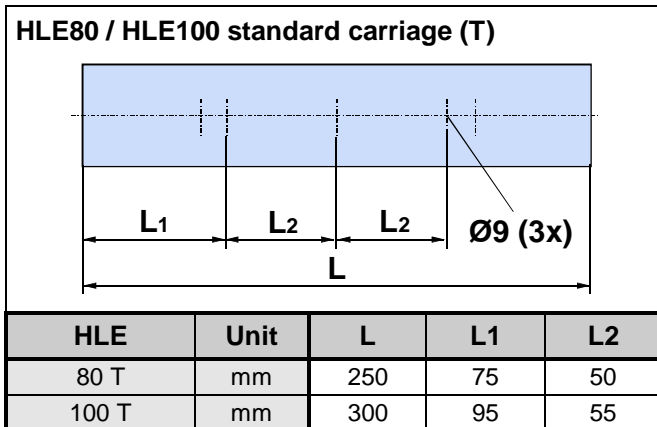

Order code

HLE linear actuator	L	E					P														
Drive system																					
Timing belt drive																					B
Idler unit																					N
Model / size																					
80 (Dimensional drawing on page 8)																					0 8 0
100 (Dimensional drawing on page 10)																					1 0 0
150 (Dimensional drawing on page 12)																					1 5 0
Carriage																					
Standard carriage with load attachment plate																					S
Standard carriage with bar																					T
Extended carriage with load attachment plate																					E
Extended carriage with bar																					F
Special carriage with load attachment plate (on request)																					C
Special carriage with bar (on request)																					D
Extras (e.g. two or more carriages)																					X
Guide system																					
Plastic sheathed wheels																					P
Stroke																					
Specify desired stroke (in mm)																					n n n n n
Drive options (refer to figures on page 16)																					
Shaft on left (Dimensional drawings: refer to pages 9, 11, 13)																					S L
Shaft on right (Dimensional drawings: refer to pages 9, 11, 13)																					S R
Shaft on both sides (Dimensional drawings: refer to pages 9, 11, 13)																					S B
Without drive – prepared for drive to be fitted on left																					N L
Without drive – prepared for drive to be fitted on right																					N R
Gearbox on left																					D L
Gearbox on right																					D R
Gearbox on left and shaft on right (Dimensional drawings: refer to pages 9, 11, 13)																					L R
Gearbox on right and shaft on left (Dimensional drawings: refer to pages 9, 11, 13)																					R L
Without drive – idler unit (Dimensional drawing: refer to page 14)																					N N
Extras (others, e.g. central drive with dual axes) (on request)																					X X
Gearbox flange																					
Flange suitable for Stöber planetary gears P3																					A
Flange suitable for Stöber planetary gears P4																					B
Flange suitable for Stöber planetary gears P5																					C
Flange suitable for Stöber planetary gears P7																					D
Flange suitable for Stöber planetary gears P4, compatible with PL90																					Q
Flange suitable for Stöber planetary gears P5, compatible with PL115																					R
Without drive housing – idler unit																					N
Extras (others, not standard) (on request)																					X
Centre distance with dual axes (from centre of axis to centre of axis)																					
Specify desired centre distance (in mm)																					n n n n n
Specify for single axis or idler unit																					0 0 0 0 0
Steel strip cover (refer to page 4)																					
Without steel strip cover																					N
With steel strip cover (protection class IP30)																					C
Material version																					
Standard – version																					N
Corrosion-resistant version (V2A)																					V
Linear encoder																					
Without linear encoder (standard)																					N
With linear encoder																					L

HLE – Linear actuators with timing belt drive

Drive options

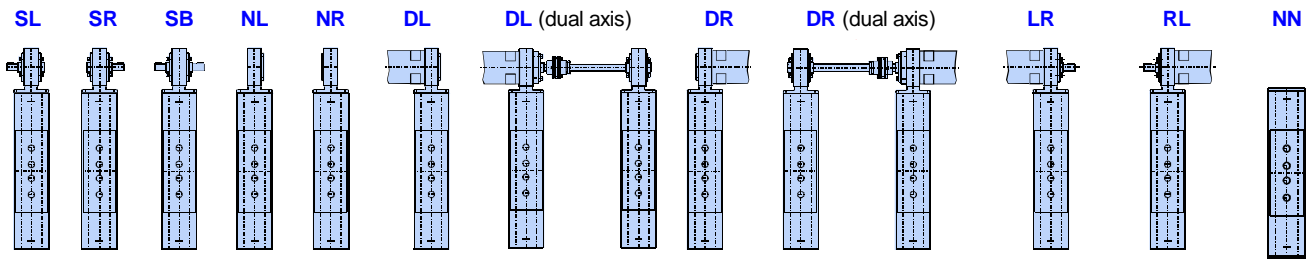

HLEZ linear actuators with rack-and-pinion drive

- for long travel paths with high rigidity and accuracy



Contents:

The HLEZ - a combined technology	18
Construction of the HLEZ.....	19
Technical data.....	20
Dimensional drawings	22
HLEZ100.....	22
HLEZ150.....	22
Gearbox fitting - examples	23
HLEZ150 with planetary gearbox P5....	23
HLEZ150 with worm gearbox.....	23
Order code	24
Mechanical accessories	25
Assembly angle plate	25
Clamping profile.....	26
T-nuts and bolts.....	26
Link shaft bearing	27
External buffer stop	27
Cable carrier	28
Longitudinal flange connection set	30
Attachment of position sensors	31
Tripping plate	32
Mechanical limit switch	33
Electrical limit switch.....	33
Distribution box.....	34
Other accessories and software	34

The "endless" linear unit

for guiding, transporting and positioning over long strokes, offers:

- ◆ Long travel distances, up to 50 m
- ◆ High speeds in practical applications, up to 5 m/s
- ◆ High levels of load capacity, horizontally up to 1000 kg / vertically up to 300 kg
- ◆ Up to 64 Nm permitted drive torque
- ◆ Repeatability, up to ± 0.05 mm
- ◆ Several carriages possible on one linear unit
- ◆ Two profile sizes: HLEZ100 and HLEZ150
- ◆ Simple, rapid installation and start-up

Typical fields of application

as part of advanced, cost-effective construction of machines and handling systems:

- ◆ **Materials handling** e.g. palletization, feeding, removal
- ◆ **Textile machinery building** e.g. cross-cutting, slitting and stacking, quilting, seam stitching
- ◆ **Process engineering** e.g. painting, coating, bonding
- ◆ **Storage technology** e.g. commissioning, inventory
- ◆ **Construction technology:** e.g. peeling, laying reinforcement of concrete
- ◆ **Clean room technology** e.g. wafer transport, wafer coating
- ◆ **Machine tool building** e.g. workpiece loading, tool changing
- ◆ **Testing technology** e.g. guiding ultrasonic sensors

The combined technology

of the linear actuator and rack of offers the following advantages:

- ◆ High dynamic response, even over long travel distances, due to:
 - ◆ the short timing belt, regardless of travel length
 - ◆ the lightweight carriage
 - ◆ the backlash-free drive
- ◆ High positional accuracy, regardless of stroke length
- ◆ Option of several carriages per linear unit, making overlapping strokes along a single axis possible
- ◆ Easy servicing at long intervals
- ◆ Grooves running in the profiles on all sides to enable mounting of the HLEZ to a supporting structure, fitting attachments or as cable ducts
- ◆ Grooves in the load attachment plate for flexible installation

The HLEZ - a combined technology

The new design

Taking the HLE linear units as its base, a new rack-and-pinion drive system has been designed for the HLE100 and HLE150.

The system which is especially suitable for long travel distances and high speeds, opens up a whole range of new application options. The patented rack principle permits "endless" travel whilst maintaining high accuracy. At the same time the dynamic characteristics of the system are outstanding.

When required several carriages can be positioned on a single unit independently of each another. In combination with other HAUSER mechanical components, this allows the construction of efficient and cost-effective gantry and automation systems.

HLEZ drive principle

The HLEZ drive offers all the advantages of a rack drive, but without the usual drawbacks. The short timing belt (which is independent of travel length) reduces belt stretching to an absolute minimum.

Our experience

You can have confidence in our experience and skill because over 6000 linear axes are already in use throughout the world – whether it be in automatic textile equipment, handling systems, packaging machines, automatic painting and binding equipment, etc....

The HLEZ is found across a broad application area - in clean rooms, in the food industry, in chemical production plants and in the production of precast concrete components.

We work together with a wide range of sectors including the automobile industry, machine tool manufacturers, microelectronics manufacturers - and hopefully soon with you ...

Examples/applications

- ◆ **Sick**, Waldkirch: sensor testing equipment
- ◆ **Desarrollo**, Spain: gantry robots for transporting glass fibre coils
- ◆ **Springs**, USA: sewing textiles
- ◆ **Weckenmann**, Dormettingen: wide-area gantry robots for the precast-concrete industry
- ◆ **AZO**, Osterburken: marshalling equipment
- ◆ **EEW**, Schönberg: high-speed milling centre
- ◆ **Telecom**, Switzerland: telephone accessory order picking system
- ◆ **LT Engineering**, Switzerland: shelf-picking unit for small parts stores
- ◆ **Allied Signal**, USA: sewing air-bags
- ◆ **Weber-Haus**, Linx: boring and sawing cut-outs for the mounting of distribution boxes and socket outlets

The lateral deflection roller pretensions the system and thereby removes backlash. Hold-down rollers ensure that sufficient teeth always remain in mesh. The combination of plastic timing belts and an aluminium rack-and-pinion is a safe

and clean drive which requires no lubrication.

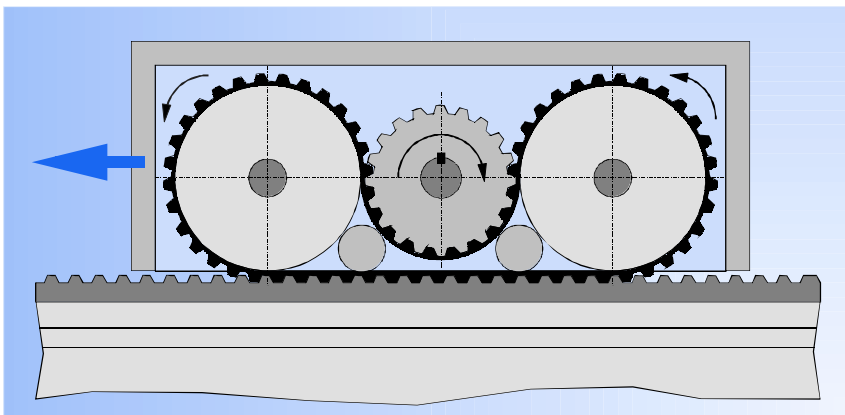

All of this offers the following advantages:

- ◆ high constant rigidity regardless of the travel or position
- ◆ Very long travel distances achievable
- ◆ high levels of accuracy
- ◆ high speeds are possible
- ◆ smooth, low-noise running
- ◆ no lubrication necessary
- ◆ any installation position possible

Construction of the HLEZ

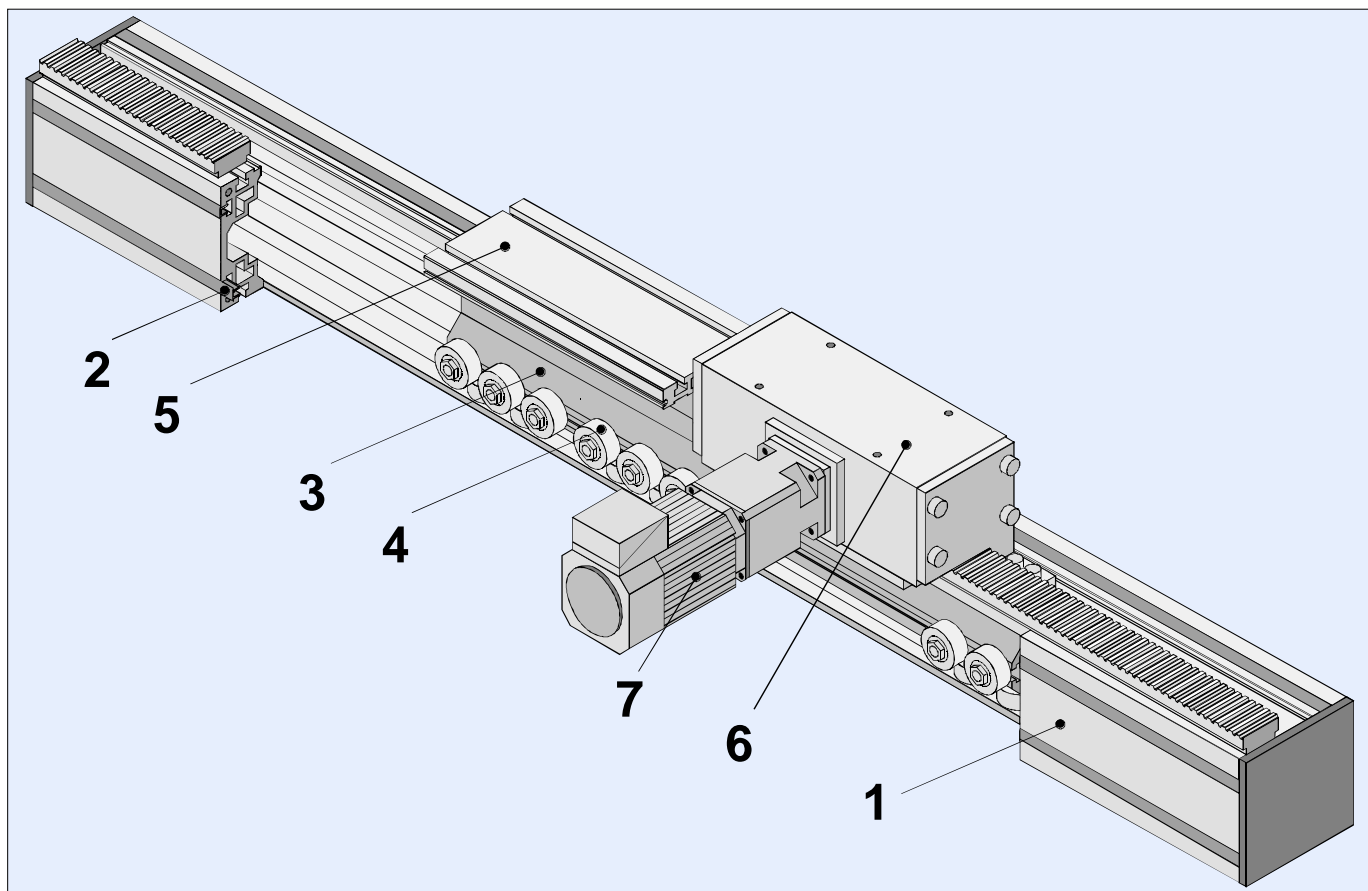

The profile (1)

Light, compact and self-supporting aluminium profile construction. Available in the following cross-sections:

100x100 mm (HLEZ100)

150x150 mm (HLEZ150)

All profiles have a total of seven grooves along their length for clamping further mechanical components and for joining several HLEZ and HLE units. These grooves also serve as attachment and mounting points for sensors and mechanical switches.

Together with the cover profiles (2), these can be used as cable ducts.

The carriage (3)

Lightweight, rigid carriage with plastic wheels mounted on roller bearings (4) and eccentric axles for playfree carriage settings on all sides.

Overall, this results in high mechanical efficiency and virtually wear-free operation. The carriage can be supplied in two lengths either standard or extended.

We can also produce special carriages for customised applications.

The load attachment plate (5)

The longitudinal grooves integrated on the top of the plate offer many options for the assembly of attachments. When used together with the clamping profiles (refer to page 26) this allows simple incorporation in a multi-axis system.

Simple and adjustable attachment of operating cams or switch lugs is provided by longitudinal grooves on the sides and on the underside of the plate.

Special designs are also available on request.

The drive module (6)

Compact drive module, can optionally be supplied fitted on either side of the load attachment plate. For a description of the drive principle, refer to page 18.

The optional Parker servo motor (7) with resolver and an appropriate planetary gearbox forms an optimum drive for dynamic and accurate applications.

When used together with the COMPAX compact servo-controller, the HLE becomes a complete, ready-to-run automation system for single and multi-axis travel and continuous path controls.

HLEZ – linear actuators with rack-and-pinion drive

Technical data

HLEZ size	Unit	HLEZ100	HLEZ150
-----------	------	---------	---------

Weight and moment of inertia

Weight of basic unit without stroke			
HLEZ with standard carriage	kg	22	53
HLEZ with extended carriage	kg	26	61
Weight of standard carriage with load attachment plate and drive module	kg	11.3	25.7
Weight of extended carriage with load attachment plate and drive module	kg	13.3	29.7
Weight per meter additional length (guide profile + rack)	kg/m	11.3	23.9
Moment of inertia of drive shaft ^{*1} (allowing for carriage with load attachment plate and drive module)			
Standard carriage S	kgcm ²	33.3	325
Extended carriage E	kgcm ²	37.9	363.4

Travel, speed and efficiency

Maximum speed	m/s	5.0	5.0
Maximum stroke, standard carriage S/T ² with one profile bar	mm	6102	8888
Maximum stroke, extended carriage E/F ² with one profile bar	mm	5952	8738
Max. stroke with longitudinal load attachment connection(s) ^{*3}	mm	50000	
Efficiency	%	85	

Geometry of guide profile

Cross-section	mm x mm	100 x 100	150 x 150
Moment of inertia I _x	cm ⁴	383	1940
Moment of inertia I _y	cm ⁴	431	2147
Moment of inertia I _t	cm ⁴	117	391
Modulus of elasticity	N/mm ²	0.72*10 ⁵	

Pulley data, torques and forces

Travel distance per revolution	mm/rev	100	200
Diameter of pulley (D _A)	mm	31.83	63.66
Number of teeth on pulley		20	20
Timing belt pitch	mm	5	10
Maximum drive torque	Nm	16	64
Feed force	N	1000	2000
Repeatability ^{*4}	mm	± 0.05	



Please refer any departures from these technical standards to HAUSER.

*1: Additional inertia moment caused by effective load: $J_{\text{eff. load}} = m_{\text{eff. load}} \times \frac{1}{4} D_A^2$ (Motor and gearbox weight are added to form the effective load)

*2: Longitudinal load attachment connection is available for greater travel paths (refer to page 30).

*3: The travel distance is unlimited as far as the linear actuator is concerned - it is only dependent on the power supply to drive unit.

*4: Applies to the linear actuator with drive module, without drive.



Technical data issued 06/99, safety factor taken into consideration S=1. Data applies to a temperature range of between -10°C and +40°C

HLEZ – linear actuators with rack-and-pinion drive

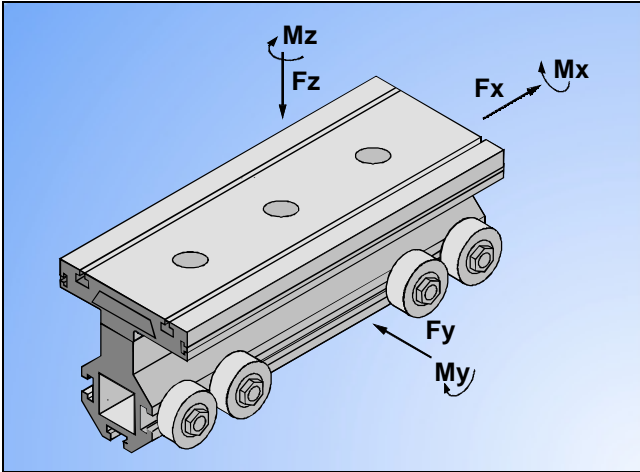

The force and torque ratings of the carriage are speed-dependent. The curves shown in the graphs apply to a standard carriage (S/T).

With the extended carriage (E/F), all the values apart from F_x (load-bearing capacity of rack and pinion drive) can be doubled if the load is applied equally to both halves of the carriage or distributed uniformly along its entire length.

The curves show the maximum load-bearing capacity of a carriage in one direction of force or torque. If several loads are applied from different directions, the values stated in the curves **must be derated**, i.e. the load or speed should be reduced if necessary.

For precise carriage dimensioning, our software "DimAxes" is available - calculation is identical to the corresponding HLE size (refer to "Other accessories and software", page 34).

F_x [N] (Load-bearing capacity of rack and pinion drive)

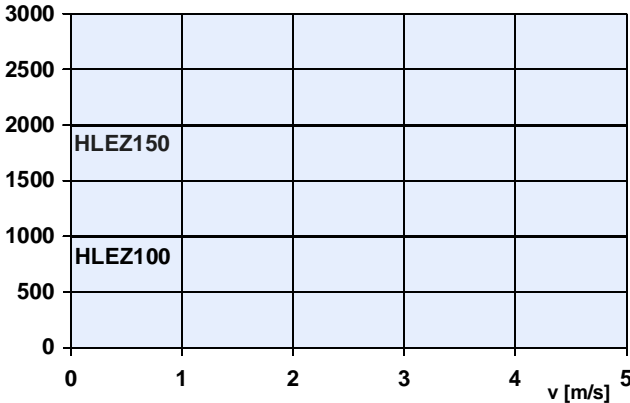

M_x [Nm]

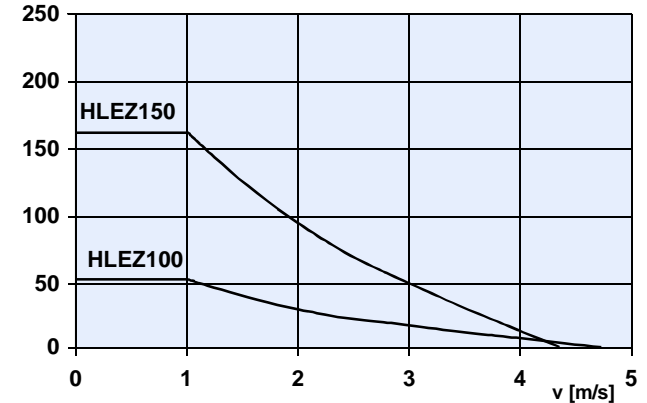

F_y [N]

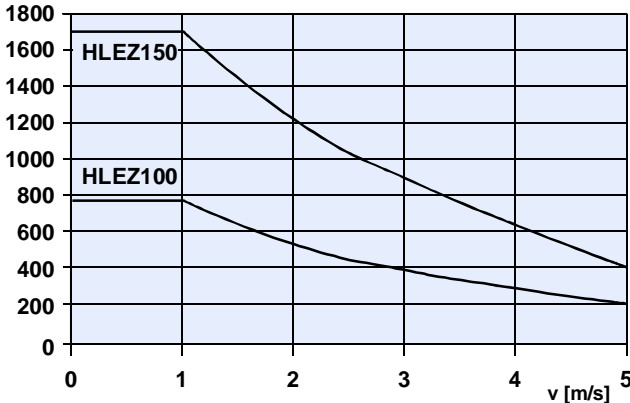

M_y [Nm]



F_z [N]

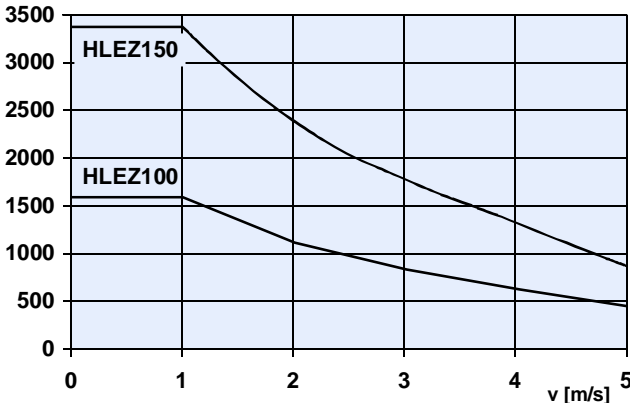

M_z [Nm]

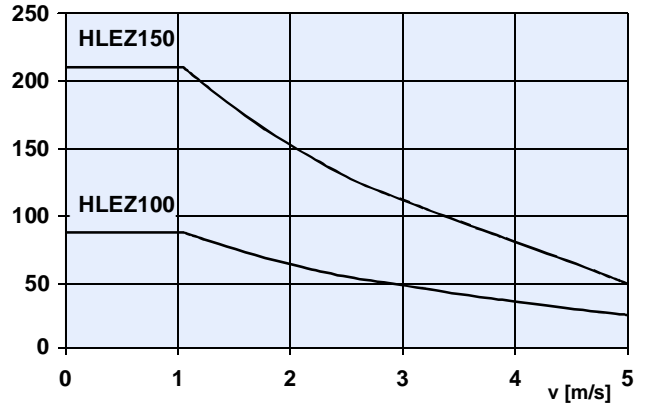

HLEZ – linear actuators with rack-and-pinion drive

Dimensional drawings

HLEZ100

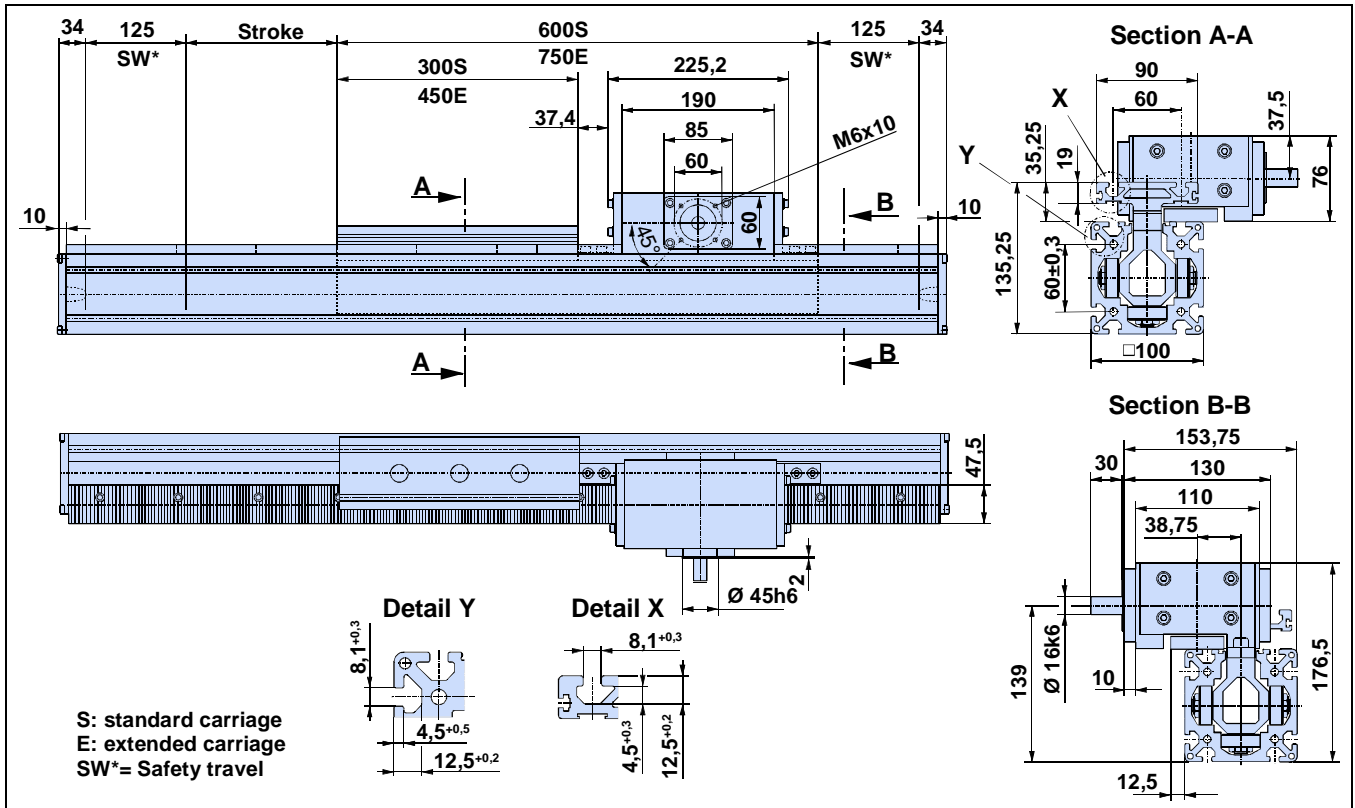

HLEZ150

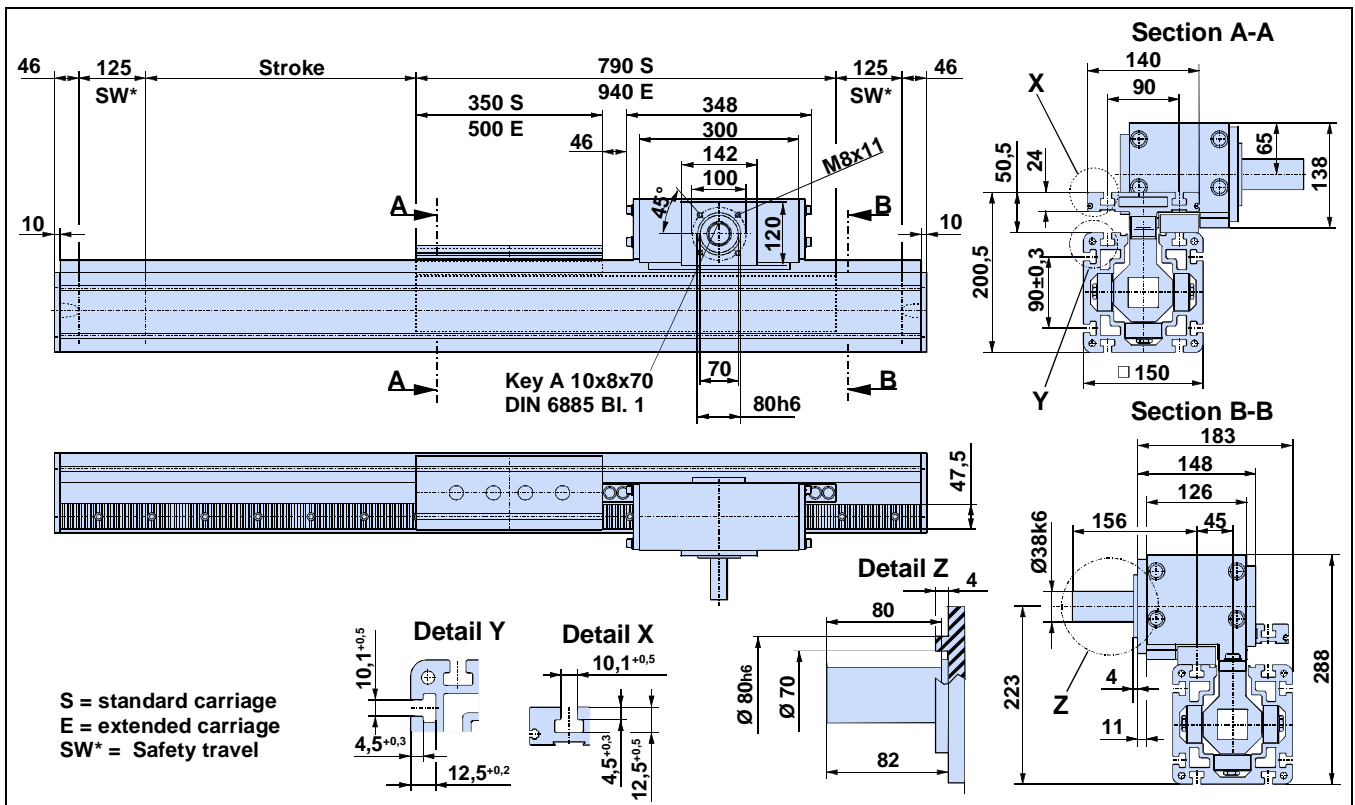

Gearbox fitting - examples

HLEZ150 with planetary gearbox P5 (PL115 or PLE120-compatible type)

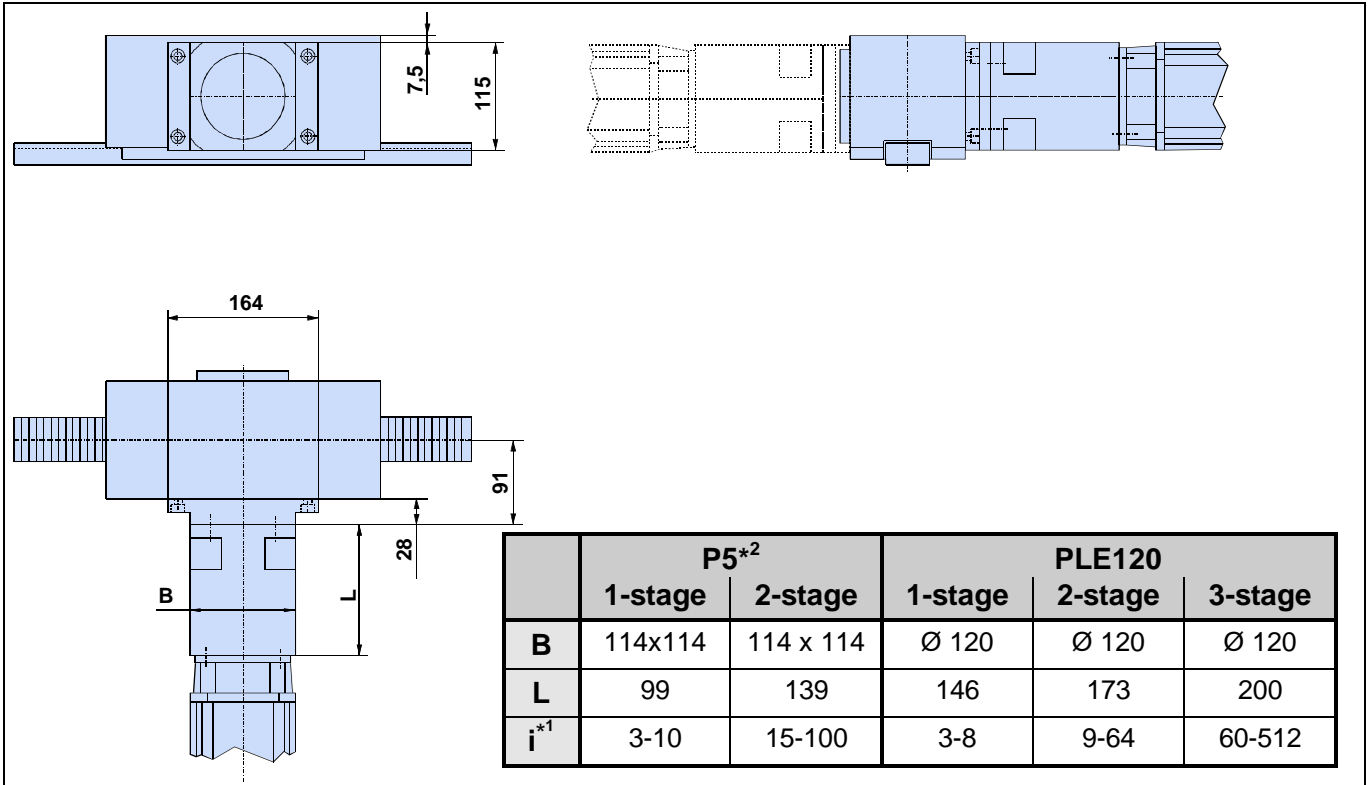

*1: Ratio range can be supplied; *2: gearbox P5 compatible with PL115, can be supplied as from August 1999.

HLEZ150 with worm gearbox 52.314.06

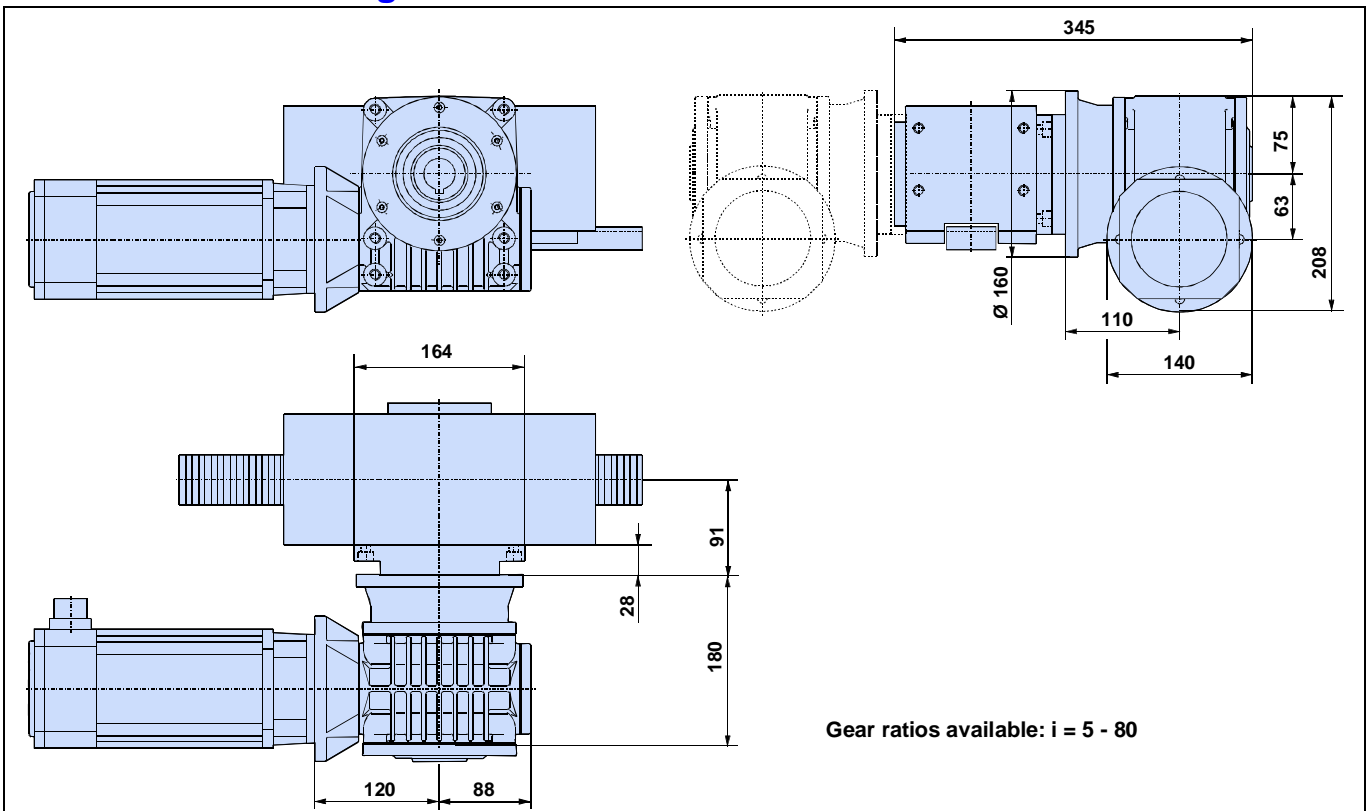

HLEZ – linear actuators with rack-and-pinion drive

Order code

HLEZ linear unit	L	E	Z					P											N	N	N
Drive system																					
Rack-and-pinion drive	Z																				
Model / size																					
100 (Dimensional drawing, page 22)	1	0	0																		
150 (Dimensional drawing, page 22)	1	5	0																		
Carriage																					
Standard carriage with load attachment plate	S																				
Standard carriage with bar	T																				
Extended carriage with load attachment plate	E																				
Extended carriage with bar	F																				
Special carriage with load attachment plate (on request)	C																				
Special carriage with bar (on request)	D																				
Extras (e.g. 2 or more carriages)	X																				
Guide system																					
Plastic sheathed wheels	P																				
Stroke																					
Specify desired stroke (in mm)	n	n	n	n	n																
Drive options (for definition of on right/on left: see figure below)																					
Shaft on left	S	L																			
Shaft on right	S	R																			
Gearbox on left	D	L																			
Gearbox on right	D	R																			
Extra (other drive versions)	X	X																			
Gearbox flange																					
Flange suitable for worm gearbox 52.314.06	L																				
Flange suitable for planetary gearbox P5 (PL115 or PLE120 compatible type)	R																				
Extras (others, not standard) (on request)	X																				
Centre distance with dual axes (from centre of axis to centre of axis)																					
Specify for single axis or idler unit	0	0	0	0	0																
Specify desired centre distance (in mm) – no standard – only on request!	n	n	n	n	n																
Steel strip cover																					
Without steel strip cover (standard)	N																				
Material - version																					
Standard – version	N																				
Linear encoder																					
Without linear encoder (standard)	N																				

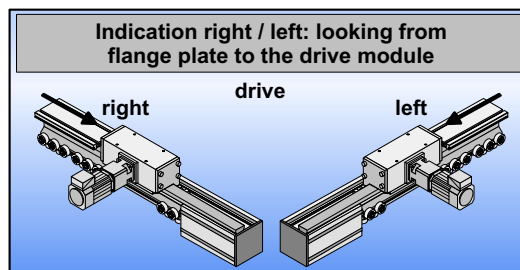

Mechanical accessories

Assembly angle plate

The assembly angle plate is used to connect an HLE or HLEZ

- to another linear actuator
- to the subframe (a HAUSER profile can be used as the support)
- to other machine components

This is available in various sizes, with equal or unequal legs, both with through-holes.

Assembly angle plate with equal legs

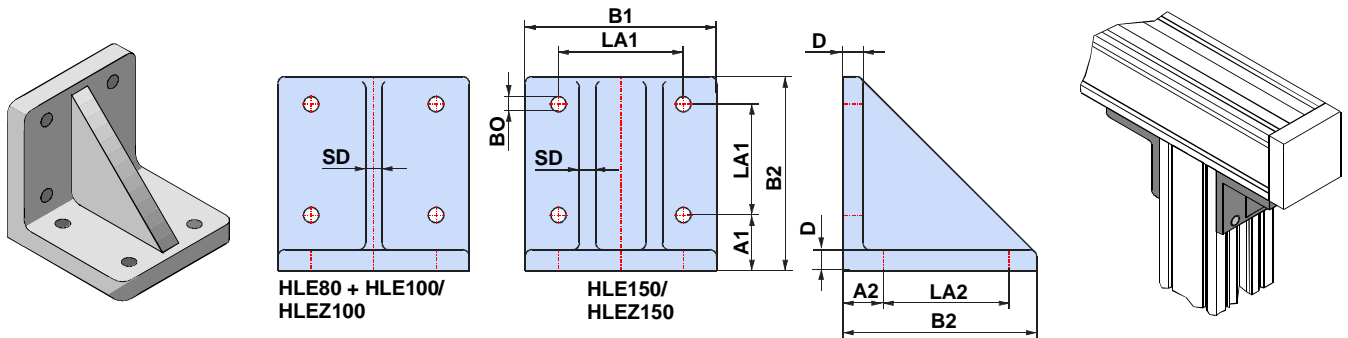

Model / size	Type	A1	A2	BO	B1	B2	D	LA1	LA2	SD	Art. no.
HLE80	MW 70/70	20	30	Ø 9	68	70	10	40	30	10	500-000503
HLE100 / HLEZ100	MW 90/90	20	30	Ø 9	88	90	10	60	50	10	500-000512
HLE150 / HLEZ150	MW 140/140	30	40	Ø 11	138	140	15	90	80	12	500-000523

Assembly angle plate with unequal legs

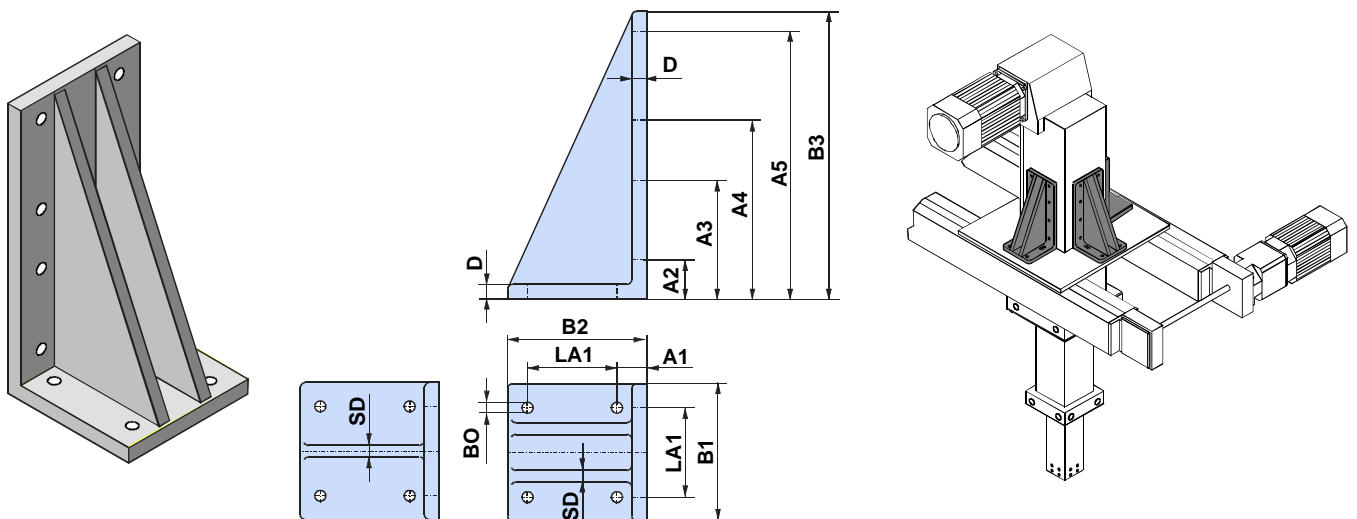

Model / size	Type	A1	A2	A3	A4	A5	BO	B1	B2	B3	D	LA1	SD	Art. no.
HLE80	MW 70/150	20	30	60	100	140	Ø 9	68	70	150	10	40	10	500-000504
HLE100 / HLEZ100	MW 90/190	20	30	80	120	180	Ø 9	88	90	190	10	60	10	500-000513
HLE150 / HLEZ150	MW 140/290	30	40	120	180	270	Ø11	138	140	290	15	90	12	500-000524

Accessories for HLE and HLEZ

Clamping profile

The clamping profile is used in conjunction with the standard load attachment plate to rapidly install and fasten various combinations of HAUSER linear units. Two clamping profiles are required to fasten an HLE or HLEZ to a load attachment plate. The following table shows the profiles required for the various axis combinations:

bottom \ top	HLE80	HLE100 / HLEZ100	HLE150 / HLEZ150
HLE80	KP70cM6 (Art.no.: 500-000904)	---	---
HLE100 / HLEZ100	KP90cM6 (Art.no.: 500-000905)	KP90cM6 (Art.no.: 500-000905)	---
HLE150 / HLEZ150	KP140c2 (Art.no.: 500-000903)	KP140c2 (Art.no. 500-000903)	KP140c1 (Art. no.500-000902)

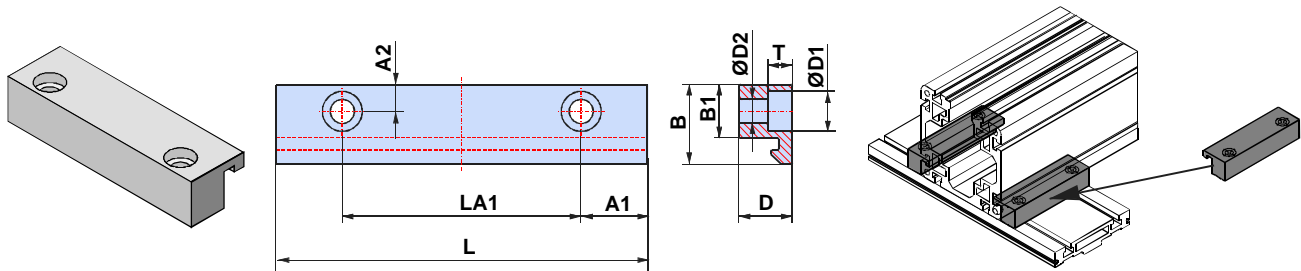

Model / size	Type	A1	A2	B	B1	D	D1	D2	L	LA1	T	Art. no.
HLE80	KP70cM6	15	10	30	20	20	Ø 11	Ø 6.6	70	40±0.2	7	500-000904
HLE100 / HLEZ100	KP90cM6	15	10	30	20	20	Ø 11	Ø 6.6	90	60±0.2	7	500-000905
HLE150 / HLEZ150	KP140c1	25	12	40	25	30	Ø 15	Ø 9	140	90±0.1	9	500-000902
HLE150 / HLEZ150	KP140c2	25	10	30	20	20	Ø 15	Ø 9	140	90±0.1	9	500-000903

T-nuts and bolts

The T-nuts and bolts are used to fasten any element into the T-grooves of the profile and to the upper side of the flange plate.

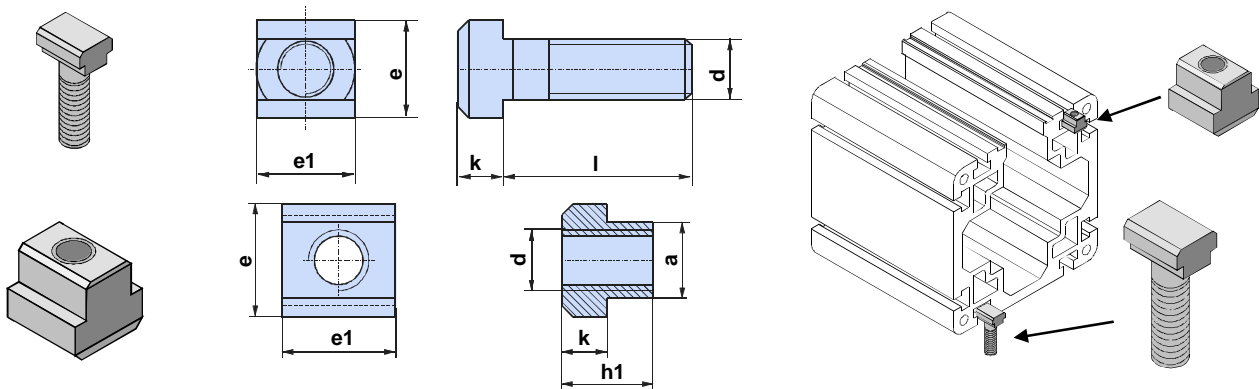

Model / size	Designation	a	d	e	e1	1h	k	l	Art. no.
HLE80+100 / HLEZ100	Bolt DIN787 M8x8x25	--	M8	13	13	--	6	25	131-700001
HLE80+100 / HLEZ100	Bolt DIN787 M8x8x32	--	M8	13	13	--	6	32	131-700002
HLE80+100 / HLEZ100	Bolt DIN787 M8x8x40	--	M8	13	13	--	6	40	131-700003
HLE150 / HLEZ150	Bolt DIN787 M10x10x25	--	M10	15	15	--	6	25	131-700007
HLE150 / HLEZ150	Bolt DIN787 M10x10x32	--	M10	15	15	--	6	32	131-700008
HLE150 / HLEZ150	Bolt DIN787 M10x10x40	--	M10	15	15	--	6	40	131-700009
HLE150 / HLEZ150	Bolt DIN787 M10x10x63	--	M10	15	15	--	6	63	131-700011
HLE80+100 / HLEZ100	Nut DIN508 M6x8	8	M6	13	13	10	6	--	131-700103
HLE150 / HLEZ150	Nut DIN508 M8x10	10	M8	15	15	12	6	--	131-700104
HLE80+100 / HLEZ100	Long nut* HWN313 ZN M6x8	8	M6	13	26	10	6	--	131-700140
HLE150 / HLEZ150	Long nut* HWN313 ZN M8x10	10	M8	15	30	12	6	--	131-700141
HLE80+100 / HLEZ100	Nut ITEM St M6	without drawing							400-000033
HLE150 / HLEZ150	Nut HWN314 ZN M8x10	Rhombus form for installation at later date							131-700155

* When using a combination of two linear axes over the clamping profile, we recommend that long nuts are used

Link shaft bearing for HLE dual axes

The link shaft bearing is used to support the linking shaft of a HLE dual axis when there is a large centre distance. This bearing must be used if the critical speed is exceeded with the dual-axis linking shaft (refer to diagram on the left).

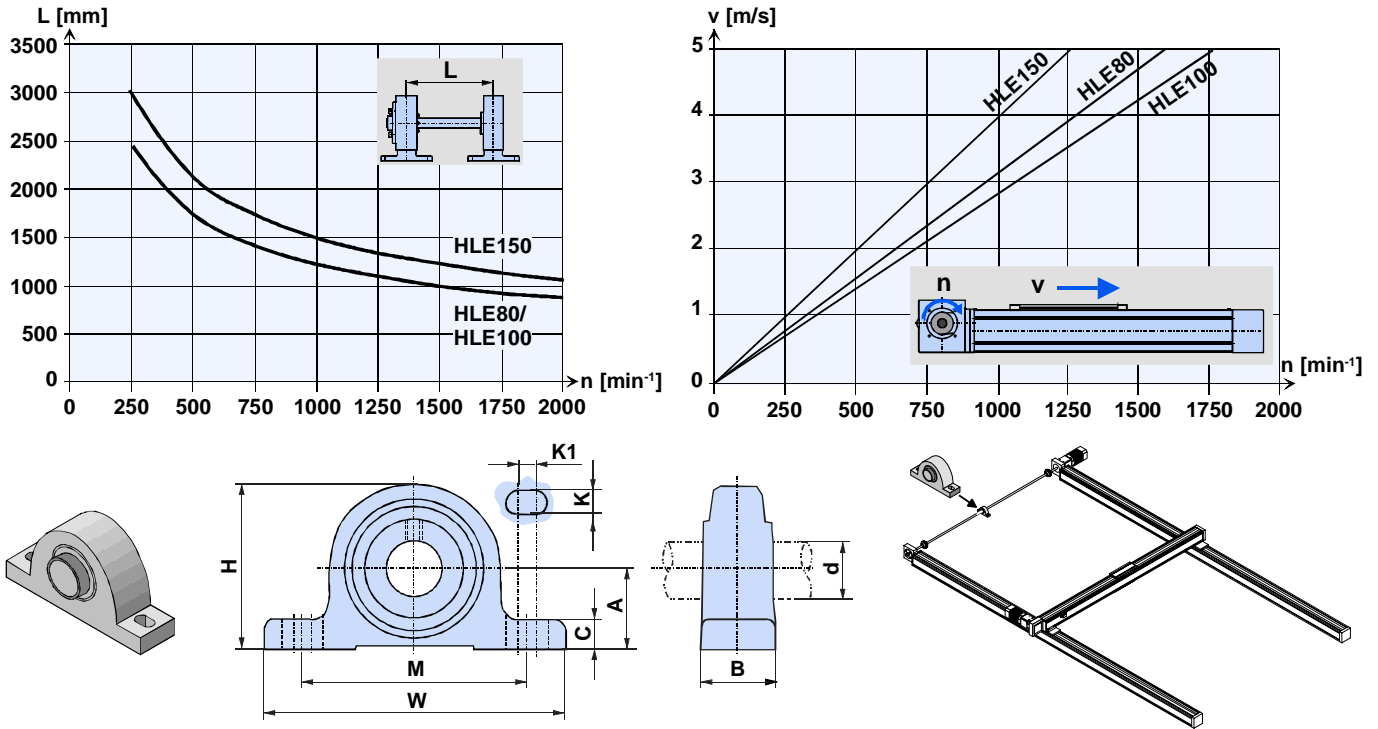

Model / size	Type	A	B	C	d	H	K	K1	M	W	Art. no.
HLE80 / HLE100	PASE20	33.3	32	14.5	∅ 20	64	11	8	97	130	416-000120
HLE150	PASE30	42.9	40	17	∅ 30	82	14	8	118	158	416-000160

External buffer stop

The external buffer stop is fitted to the grooves of the HLE/HLEZ profile and is fully adjustable.

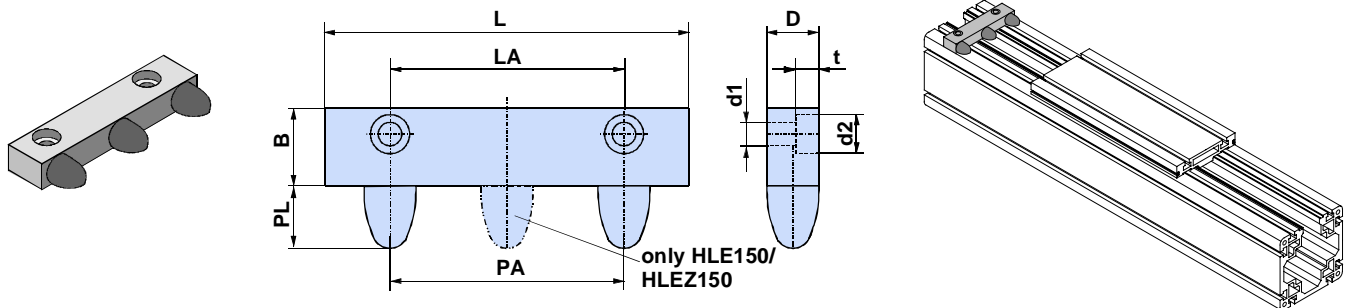

Model / size	Type	B	D	d1	d2	L	LA	PA	PL	t	Art. no. (including attachment material)
HLE80	EAP80	30	20	∅ 6.6	∅ 11	80	40	60	24	6.8	510-001185
HLE100 / HLEZ100	EAP100	30	20	∅ 6.6	∅ 11	90	60	40	24	6.8	510-001285
HLE150 / HLEZ150	EAP150	30	20	∅ 9	∅ 15	140	90	90	24	9	510-001385

Accessories for HLE and HLEZ

Cable carrier

A cable carrier is needed when making power connections to moving elements. The cable carrier chain consists of glass fibre reinforced polyamide, and the support profile is made of aluminium.



The process for fully determining the dimensions of a cable carrier is very complex. The examples listed below represent simple applications, but more data will normally be required when the situation is less straightforward. **The following descriptions only apply to power supplies arranged horizontally, which lie above a support profile and which are within the limits specified in the technical data.** If the application you are running is more demanding, please contact us.

Dimensions of support profile and cable carrier chain

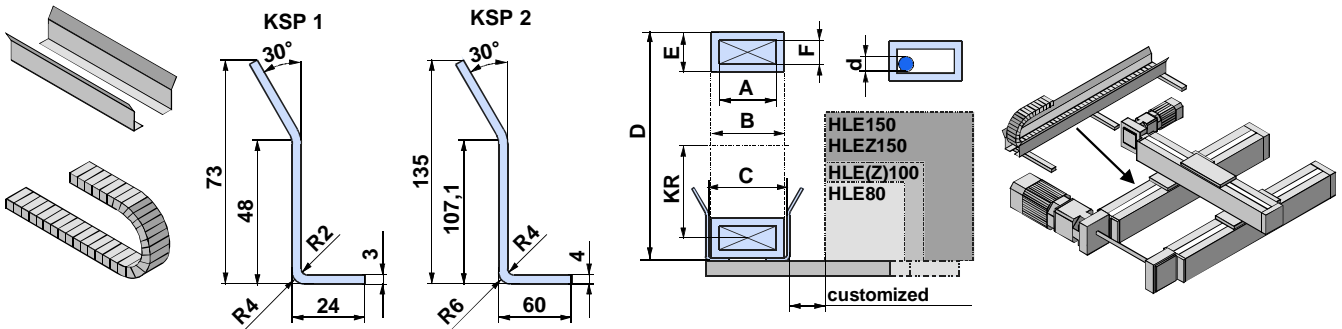

	Type	CR	A	B	C	D	E	F	d max.	Art. no. (For lengths → page 30)	
										Cable carrier chain	2 x connection angle (for dimensions → page 29)
with KSP1	0.320.20	37	13	24	29	103	25	19	11	100-906000	100-906100
	0.320.42	37	24	35	40	103	25	19	16	100-905800	100-906110
	0.450.21	52	38	54	59	147	40	24	22	100-905900	100-906090
	0.450.21	94	38	54	59	231	40	24	22	100-906200	100-906090
	0.450.41	94	58	74	79	231	40	24	22	100-906300	100-906095
	0.450.61	150	78	94	99	343	40	24	22	100-906310	100-906350
with KSP2	0.625.25	200	65	93	98	459	62	42	31	100-906505	100-906506
	0.625.45	200	108	136	141	459	62	42	31	100-906510	100-906506
	0.625.45	300	108	136	141	659	62	42	31	100-906530	100-906506
KSP1 Small cable support profile (specify length required, equal to travel length)										400-010120	
KSP2 Large cable support profile (specify length required, equal to travel length)										400-010121	

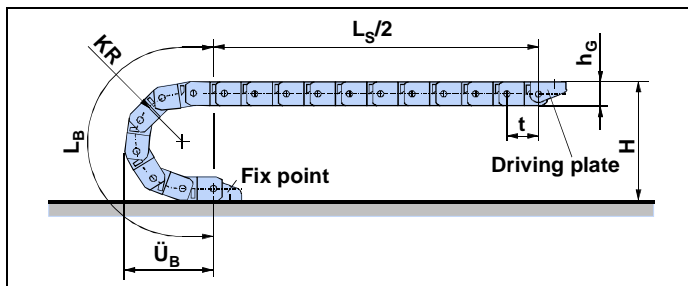

Dimensional drawings of connection points (fix point and driving plate):
Page 29

Type	Bending radius KR	Pitch t	Height hg	Curve length LB	Curve protrusion UB	Connection height H _{min} (= 2KR+hg)	Own chain weight kg/m
0.320.20	37	32	25	181	82	99	0.32
0.320.42	37	32	25	181	82	99	0.39
0.450.21	52	45	40	254	117	144	0.75
0.450.21	94	45	40	386	159	228	0.75
0.450.41	94	45	40	386	159	228	0.85
0.450.61	150	45	40	562	215	340	0.92
0.625.25	200	62.5	62	754	290	456	1.35
0.625.45	200	62.5	62	754	290	456	1.50
0.625.45	300	62.5	62	1068	390	656	1.50

Dimensional drawings of connection points

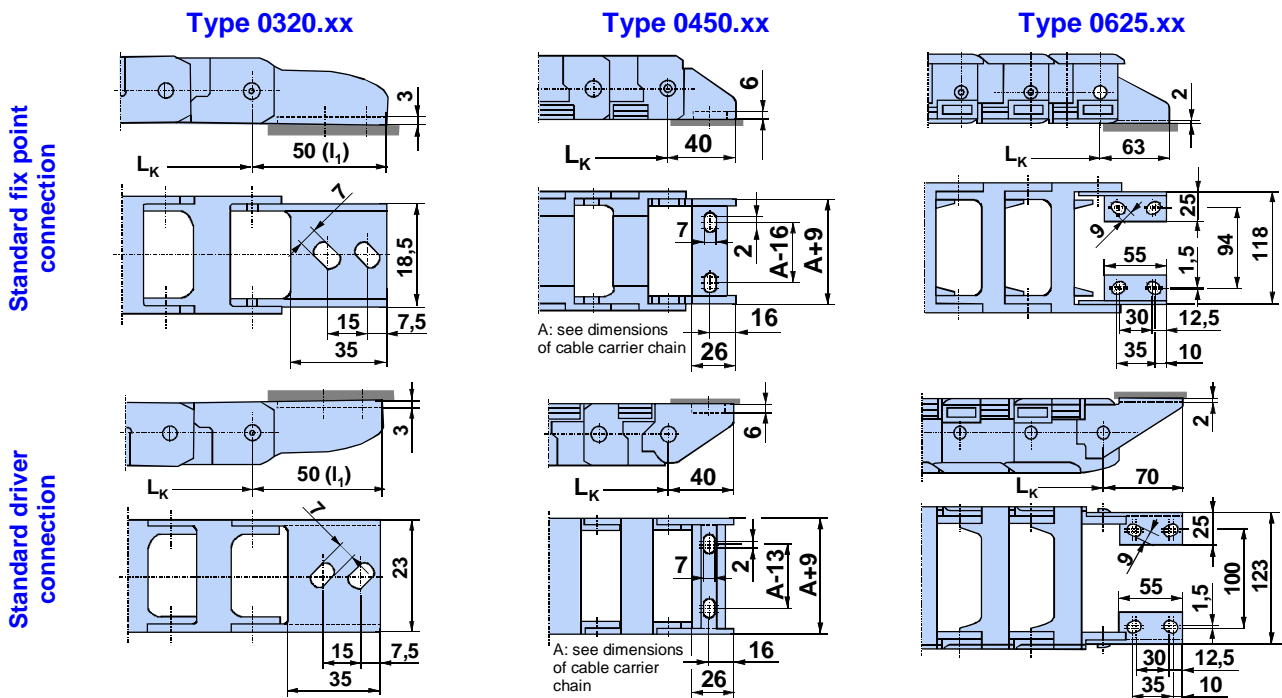

Technical data

Type	Self supporting arrangement			Self supporting arrangement with permitted deflection		
	maximum stroke [mm]	maximum speed [m/s]	maximum acceleration [m/s ²]	maximum stroke [mm]	maximum speed [m/s]	maximum acceleration [m/s ²]
0.320	2400	10	10	3500	2.5	1
0.450	3000	10	10	4400	2.5	1
0.625	5000	8	10	6000	3	1

Guidelines for using cable carriers



Use only electrical cables which are suitable for use in cable carriers. Hose lines should be highly flexible and should only extend slightly under pressure. Weight should be distributed across the cable track as evenly as possible. Cables must not be twisted when routed in the cable carrier and should be routed next to one another and as loosely as possible.

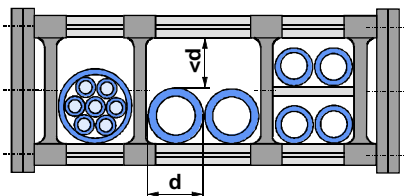

Avoid laying several lines on top of each other and laying lines of different diameters directly next to one another. If multiple layers must be used, separating strips should be inserted between each layer – should such circumstances arise, please contact HAUSER.

If there is no alternative to routing several lines beside each other without sub-divisions, the clearance height within the carrier must be less than line diameter. This is the only way of preventing the cables from twisting.

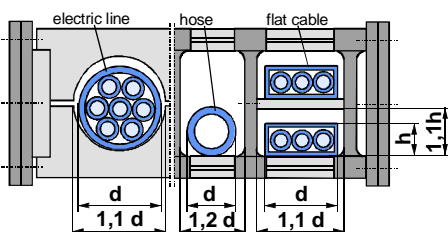

The supply cables must be able to move freely in the cable carrier – they must never be fastened or bundled together. **Separating strips must always** be inserted between flat cables routed in multiple layers.

Recommended dimensions of the space required:

- with round cables: approx. 10% of the line diameter
- with flat cables: for each, approx. 10% of the cable width and cable thickness
- with hose lines: approx. 20% of the hose diameter

Accessories for HLE and HLEZ

Highly flexible, thin lines with a low bending strength should be loosely gathered together and routed in order in a protective hose. When selecting the size of the protective hose, ensure that its area is considerably greater than the sum of the individual cross-sectional areas. As a guide, allow approximately 10 % of the diameter of each line as clearance.

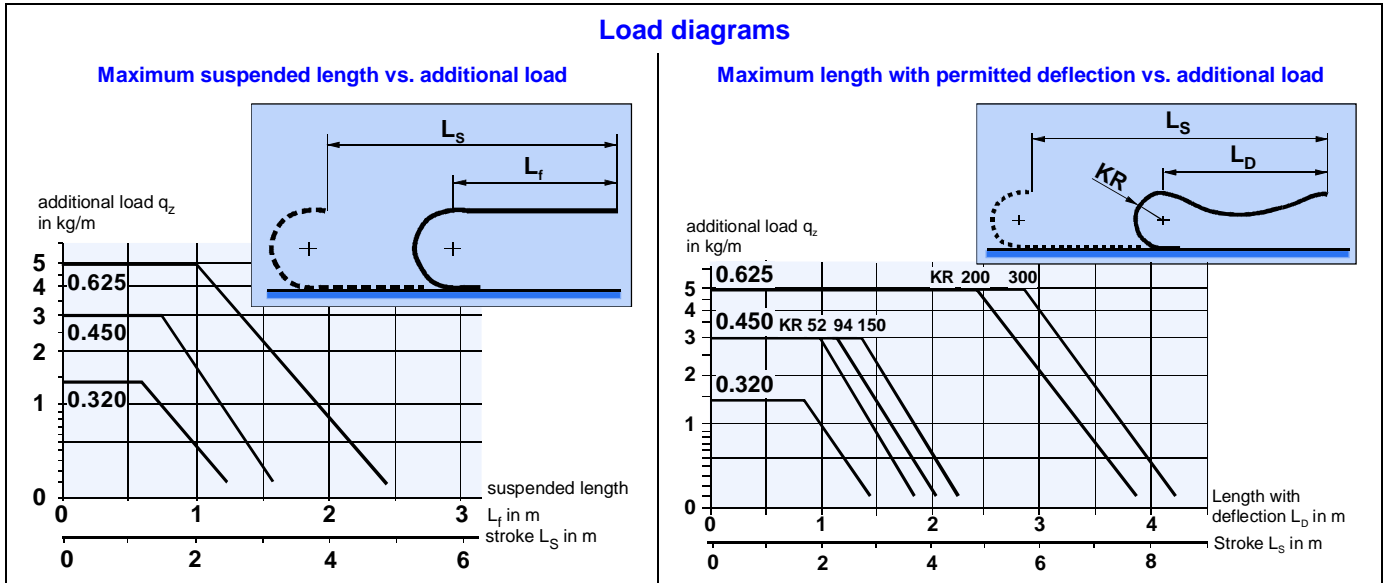

Determining the chain length

Suspended chain

$$L_K = \frac{L_S}{2} + L_B$$

0.320: rounded to a multiple of 32 mm
0.450: rounded to a multiple of 45 mm
0.625: rounded to a multiple of 62.5 mm

Chain with permitted deflection

$$L_K = \frac{L_S + KR}{2} + L_B$$

0.320: rounded to a multiple of 32 mm
0.450: rounded to a multiple of 45 mm
0.625: rounded to a multiple of 62.5 mm

Longitudinal flange connection set (option V)

Longitudinal flange plates make it possible to move more than the standard available stroke. A flange connection is always necessary if the maximum travel path is exceeded (refer to Technical data, pages 6 and 20). Profile sections should normally be split equally, with the separation point close to a fixing point. The bearing distance should generally be between 1.0m and 1.5m. If a longitudinal flange connection is used to extend the travel distance, the load data must be reduced as shown in the table below. An HLE with a longitudinal flange connection should only be installed with the profile aperture in the top or the bottom.

	Unit	HLE80	HLE100	HLE150	HLEZ100	HLEZ150
maximum permitted load	N	$0.5 \times Fx^{-1}$	$0.5 \times Fx^{-1}$	$0.5 \times Fx^{-1}$	unchanged	
Speed	m/s	< 1	< 1	< 1		
Acceleration	m/s ²	< 1	< 1	< 1		
Repeatability	mm	> ±0.5	> ±0.5	> ±0.5		

*1. Fx-HLE: refer to page 7;

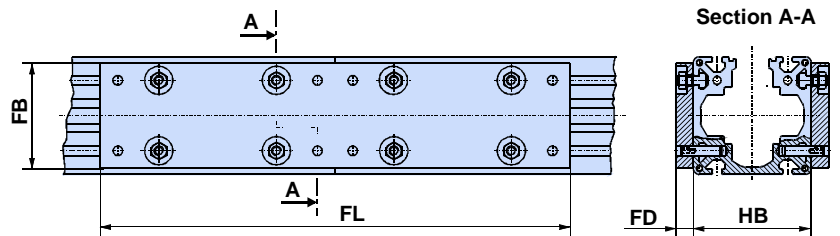
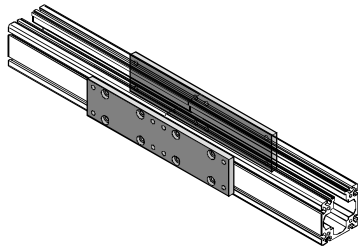

Model / size	Type	FL	FB	FD	HB
HLE80	LVS80	300	70	15	80
HLE100 / HLEZ100	LVS100	400	90	15	100
HLE150 / HLEZ150	LVS150	500	130	15	150

Attachment of position sensors and electronic accessories

Attachment variants for position sensors



Tripping plates, switches and distribution box are attached as standard on the same side as the motor. The limit switches are fitted ensuring that they are activated directly before the start of the standard safety travel (125 mm). Unless agreed otherwise, the actuator will be supplied with position switches attached using attachment variant 1 or 2. The tripping plates, switches and distributor sockets are described on page 32.

Variant 1: HLE with 3 integrated proximity switches (standard for HLE with load attachment plate)

This sensor attachment is made as standard at the factory. This variant is only possible in the HLEZ, or the HLE carriage version with bar (T/F/D) and in the corrosion-resistant V2A version (V), if switch lugs are fitted by the customer.

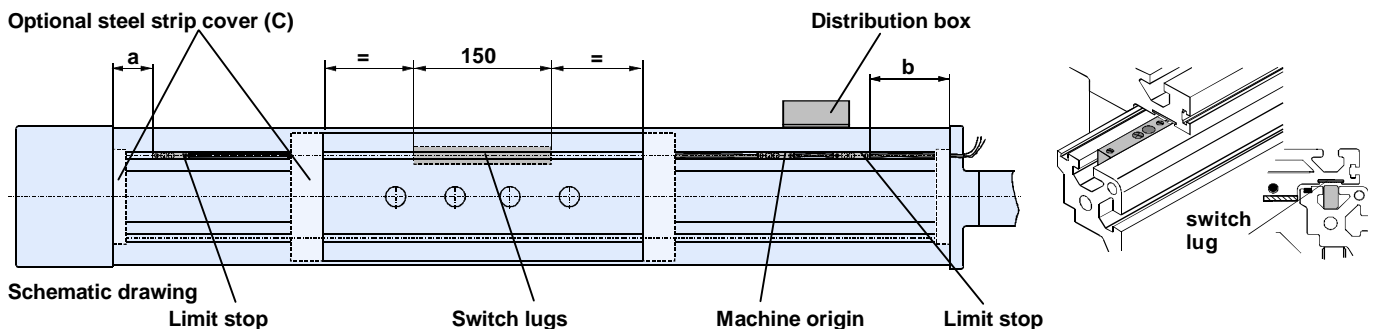

Dimensions	Unit	Standard - HLE						HLE with steel strip cover					
		HLE80		HLE100		HLE150		HLE80		HLE100		HLE150	
		S	E	S	E	S	E	S	E	S	E	S	E
a	mm	187	262	212	287	249	324	232	307	257	332	294	369
b	mm	171	246	196	271	221	296	216	291	241	316	266	341

Variant 2: HLE or HLEZ with 3 external proximity switches

This sensor attachment is made as standard at the factory for the HLEZ and the HLE versions with bar (T/F/D) and in the corrosion-resistant V2A version (V).

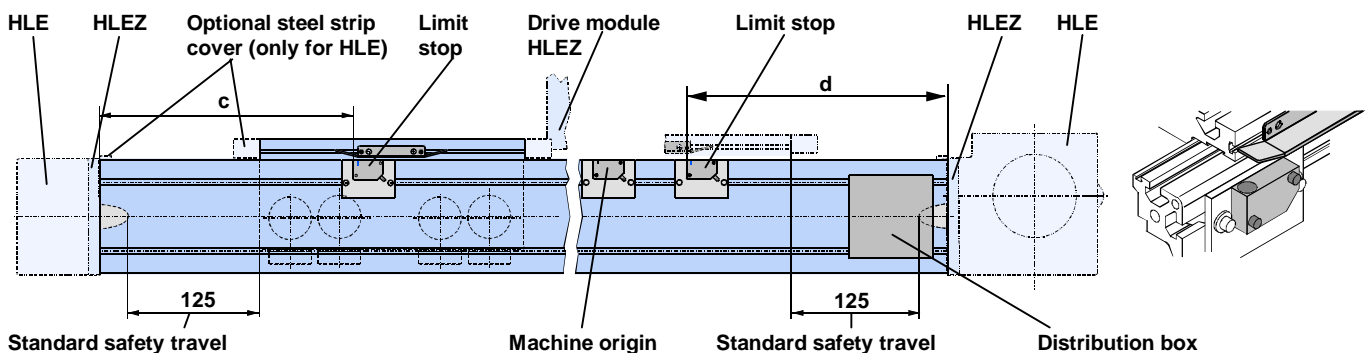

Dimensions	Unit	Standard - HLE						HLE with steel strip cover						HLEZ			
		HLE80		HLE100		HLE150		HLE80		HLE100		HLE150		HLEZ100		HLEZ150	
		S/T	E/F	S/T	E/F	S/T	E/F	S/T	E/F	S/T	E/F	S/T	E/F	S/T	E/F	S/T	E/F
c	mm	223	298	248	323	285	360	268	343	293	368	330	405	248	323	285	360
d	mm	235	310	260	335	297	372	280	355	305	380	342	417	560	635	737	812

The tripping plate is loosely attached in the carriage version with bar (T/F).

Accessories for HLE and HLEZ

Variant 3: HLE with 2 mechanical end switches and one proximity switch

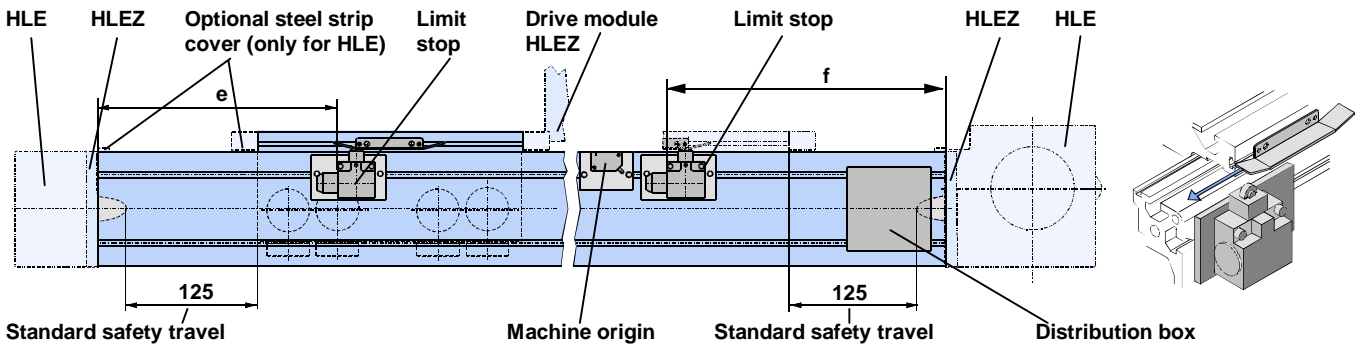

Dimensions	Unit	Standard - HLE						HLE with steel strip cover						HLEZ			
		HLE80		HLE100		HLE150		HLE80		HLE100		HLE150		HLEZ100		HLEZ150	
		S/T	E/F	S/T	E/F	S/T	E/F	S/T	E/F	S/T	E/F	S/T	E/F	S/T	E/F	S/T	E/F
e	mm	204	279	229	304	266	341	249	324	274	349	311	386	229	304	266	341
f	mm	255	330	280	355	317	392	300	375	325	400	362	437	580	655	757	832

The tripping plate is loosely attached in the carriage version with bar (T/F).

Variant 4: HLE with 1 mechanical end switch and 1 proximity switch, both attached to the moving carriage

This is the preferred variant for robot systems if the connections to the switches come via the cable carrier. The tripping plates must be assembled in a manner which ensures that the mechanical switch is actuated immediately before the start of the safety travel.

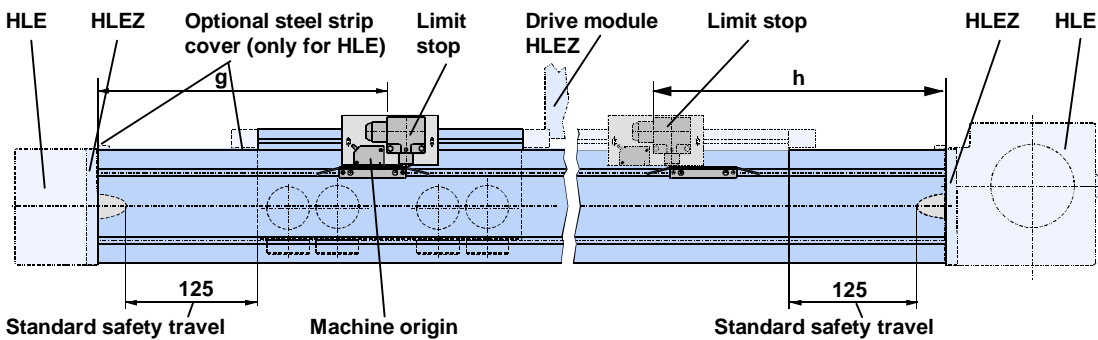

Dimensions	Unit	Standard - HLE						HLE with steel strip cover						HLEZ			
		HLE80		HLE100		HLE150		HLE80		HLE100		HLE150		HLEZ100		HLEZ150	
		S/T	E/F	S/T	E/F	S/T	E/F	S/T	E/F	S/T	E/F	S/T	E/F	S/T	E/F	S/T	E/F
g	mm	270	345	295	370	332	407	315	390	340	415	377	452	295	370	332	407
h	mm	287	362	312	387	349	424	332	407	357	432	394	469	603	678	780	855

The initiator and the limit switch are loosely attached in the carriage version with bar (T/F).

Tripping plate

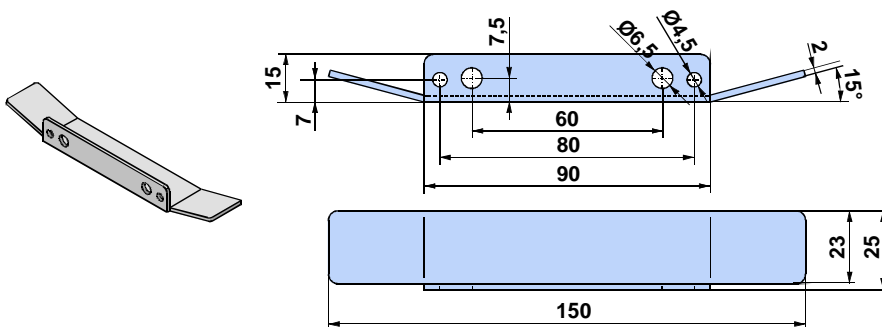

The tripping plate is suitable for all standard load attachment plates. It is mounted at the side of the flange plate using cheese-head screws and square nuts.

Mechanical limit switch

The switching button complies with DIN EN 50047. The contacts satisfy the safety requirements in accordance with EN 60947-5-1 by virtue of forced opening (positively driven).

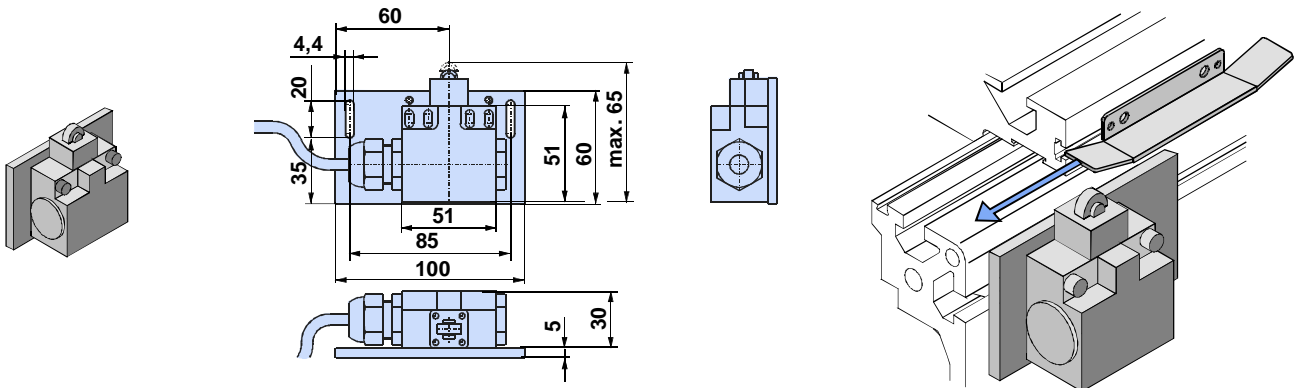

Electrical limit switch

There are two variants of inductive proximity sensors:

- Integrated sensors:** These are installed in a T groove on the upper side of the profile (standard with flange plate)
- External sensors:** These are attached to the outside of the profile (and are used for carriage version with bar T/F or for the corrosion-resistant version V)

The sensors are either activated by a tripping plate fastened to the side of the flange plate (external sensors) or by a switch lug attached to the underside of the flange plate (integrated sensors – can only be used for the HLE).

Integrated sensors:

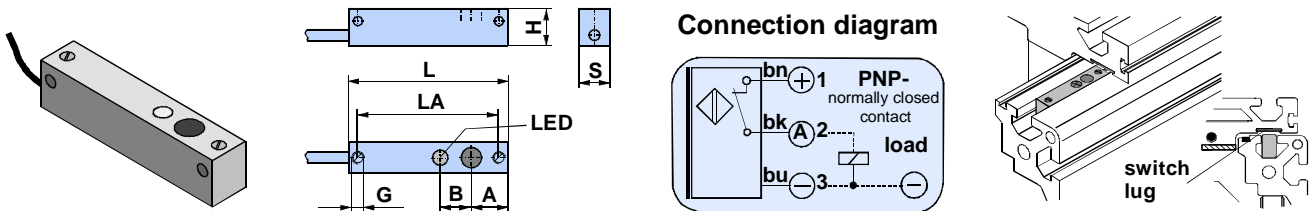

Model / size	A	B	G	H	L	LA	S
HLE80 / HLE100	12	8	M4	12	40	34	8
HLE150	12	8	M4	12	52	46	10

Technical data		DC electrical data	
Switching distance	1.8-2.2 mm	Voltage range	10 - 30 V DC
Switch hysteresis	3 - 15 %	Supply current	≤ 10 mA
Repeatability	± 3 %	Maximum switching current	150 mA when T = 25°C
Ambient temperature	-25°C - +70°C	Voltage drop	≤ 3.5 V at a switch current of 150 mA
Type of protection	IP67	Max. switching frequency	1 kHz
Cable length	6 m	Connection cables	3 x 0.14 mm ²

Accessories for HLE and HLEZ

External sensors:

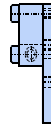
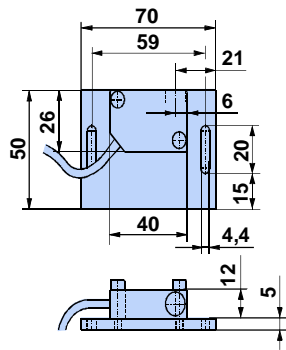
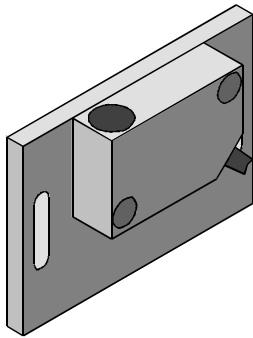

Connection diagram

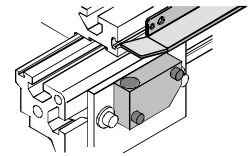
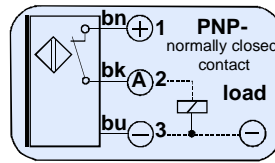

Technical data		DC electrical data	
Switching distance	2mm / 4mm ± 10%	Rated voltage	24 V DC
Switch hysteresis	≥ 1% ... ≤ 15%	Voltage range	10...35 V DC
Repeatability	0.01 mm	Supply current	≤ 15 mA
Temperature drift	≤ 10 %	Maximum load current	300 mA
Ambient temperature	-25°C - +70°C	Residual voltage	≤ 2.5 V DC
Type of protection	IP67	Max. switching frequency	2 kHz
Cable length	6 m	Connection cables	3 x 0.25 mm ²

Distribution box

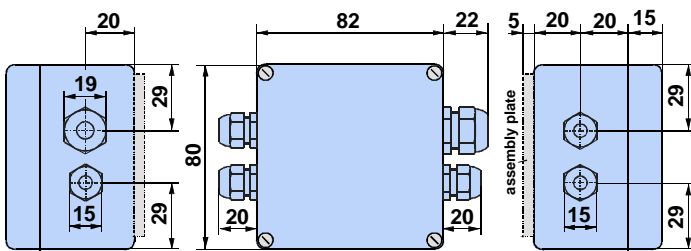

A distribution box with 2.5 m of cable is attached as standard. If a different cable length is required, please specify when ordering.

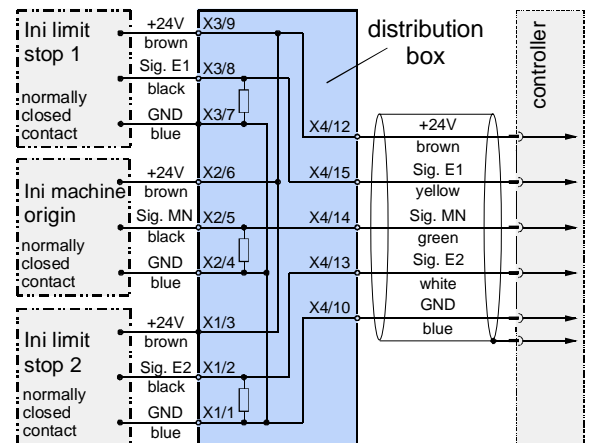

Other accessories and software



DimAxes:

Dimensioning software for the HAUSER linear axes (Art. no.: 840-014400) - for PCs as of Windows Version 3.xx.

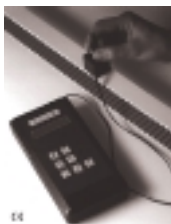

Belt tension measuring device RSM:

For accurately setting the timing belt tension (Art.no.: 037-000200).



DXF/MI files on CD-ROM:

CAD files of the HLE units. Modular system for all commonly used CAD systems

Manual for using the DXF/MI files with CD-ROM, Art.nos.:

German: 890-070001

English: 892-070001

Automation Group



Parker Hannifin GmbH

Hauser - Elektromechanik
Robert-Bosch-Str. 22
D-77656 Offenburg, Germany
Tel.: +49 (0)781 509-0
Fax: +49 (0)781 509-176
Website: www.parker-emd.com
e-mail: vertrieb@parker-emd.com

Parker Hannifin plc

Electromechanical Division - Digiplan
21 Balena Close
Poole, Dorset. BH17 7DX UK
Tel.: +44 (0)1202 69 9000
Fax: +44 (0)1202 69 5750
Website: www.parker-emd.com
e-mail: sales@parker-emd.com

Free Manuals Download Website

<http://myh66.com>

<http://usermanuals.us>

<http://www.somanuals.com>

<http://www.4manuals.cc>

<http://www.manual-lib.com>

<http://www.404manual.com>

<http://www.luxmanual.com>

<http://aubethermostatmanual.com>

Golf course search by state

<http://golfingnear.com>

Email search by domain

<http://emailbydomain.com>

Auto manuals search

<http://auto.somanuals.com>

TV manuals search

<http://tv.somanuals.com>