

# USER MANUAL

---

## VLINK MODEM Model 1068 and 1058



**PATTON**  
**Electronics Co.**



Part# 07M1068-UM  
Doc# 05816U2-001  
Rev. A  
Revised 10/17/06

SALES OFFICE  
(301) 975-1000  
TECHNICAL SUPPORT  
(301) 975-1007

An ISO-9001 Certified  
Company

Download from [Www.Somanuals.com](http://Www.Somanuals.com). All Manuals Search And Download.

## CONTENTS

<b>1.0</b>	<b>Warranty Information</b> .....	<b>4</b>
1.1	Radio and TV Interference (FCC Part 15) .....	4
1.2	CE Declaration of Conformity .....	4
1.3	Service .....	5
<b>2.0</b>	<b>General Information</b> .....	<b>6</b>
2.1	Features .....	6
2.2	Description .....	7
<b>3.0</b>	<b>Installation</b> .....	<b>8</b>
3.1	Standalone unit installation .....	8
3.2	Rack card installation .....	9
3.3	Connecting the Twisted-Pair Line Interface .....	10
3.4	Connecting the 10/100Base-T Ethernet Interface .....	11
3.5	Connecting the POTS/ISDN line .....	12
3.6	Connecting Power .....	12
<b>4.0</b>	<b>Configuration</b> .....	<b>13</b>
4.1	Configuring the hardware DIP switches .....	13
4.2	Configuring DIP Switch S1 .....	15
	Switch S1-1: Ethernet Auto Sense .....	15
	Switches S1-2 and S1-4: Data Rate .....	15
<b>5.0</b>	<b>Operation</b> .....	<b>17</b>
5.1	Power Up .....	17
5.2	Front Panel LED Status Monitors .....	17
<b>A</b>		
	<b>Specifications</b> .....	<b>20</b>
A.1	LAN Connection .....	20
A.2	Transmission Line .....	20
A.3	VDSL Line Rate .....	20
A.4	VDSL Distance .....	20
A.5	VDSL Surge Suppressor .....	20
A.6	LED Status Indicators .....	20
A.7	Power Supply .....	20
A.8	Temperature Range .....	21
A.9	Humidity .....	21
A.10	Dimensions .....	21
<b>B</b>		
	<b>MODEL 1068 series Factory Replacement Parts and Accessories</b> .....	<b>22</b>
<b>C</b>		
	<b>VLINK Series Interface Pin Assignment</b> .....	<b>24</b>
C.1	10/100Base-T Interface .....	24
	RJ-45 .....	24
C.2	VDSL Interface .....	24
	RJ-45 .....	24

	Terminal Block (1068DV/TB45 Only) .....	24
C.3	POTS/ISDN Interface .....	24
	RJ-45 .....	24
<b>D</b>		
	<b>Distance Chart, Based on 24 AWG (0.5 MM) .....</b>	<b>25</b>

## 1.0 WARRANTY INFORMATION

**Patton Electronics** warrants all VLINK modem components to be free from defects, and will—at our option—repair or replace the product should it fail within one year from the first date of the shipment.

This warranty is limited to defects in workmanship or materials, and does not cover customer damage, abuse or unauthorized modification. If this product fails or does not perform as warranted, your sole recourse shall be repair or replacement as described above. Under no condition shall **Patton Electronics** be liable for any damages incurred by the use of this product. These damages include, but are not limited to, the following: lost profits, lost savings and incidental or consequential damages arising from the use of or inability to use this product. **Patton Electronics** specifically disclaims all other warranties, expressed or implied, and the installation or use of this product shall be deemed an acceptance of these terms by the user.

**Note** Conformity documents of all Patton products can be viewed online at [www.patton.com](http://www.patton.com) under the appropriate product page.

### 1.1 RADIO AND TV INTERFERENCE (FCC PART 15)

This equipment generates and uses radio frequency energy, and if not installed and used properly—that is, in strict accordance with the manufacturer's instructions—may cause interference to radio and television reception. This equipment has been tested and found to comply with the limits for a Class A computing device in accordance with the specifications in Subpart B of Part 15 of FCC rules, which are designed to provide reasonable protection from such interference in a commercial installation. However, there is no guarantee that interference will not occur in a particular installation. If the equipment causes interference to radio or television reception, which can be determined by disconnecting the cables, try to correct the interference by one or more of the following measures: moving the computing equipment away from the receiver, re-orienting the receiving antenna, and/or plugging the receiving equipment into a different AC outlet (such that the computing equipment and receiver are on different branches).

### 1.2 CE DECLARATION OF CONFORMITY

We certify that the apparatus identified in this document conforms to the requirements of Council Directive 1999/5/EC on the approximation of the laws of the member states relating to Radio and Telecommunication Terminal Equipment and the mutual recognition of their conformity.

The safety advice in the documentation accompanying this product shall be obeyed. The conformity to the above directive is indicated by the CE sign on the device.



**This device is NOT intended nor approved for connection to the PSTN. It is intended only for connection to customer premise equipment.**

### 1.3 SERVICE

All warranty and non-warranty repairs must be returned freight prepaid and insured to Patton Electronics. All returns must have a Return Materials Authorization number on the outside of the shipping container. This number may be obtained from Patton Electronics Technical Services at:

- Tel: **+1 (301) 975-1007**
- Email: **support@patton.com**
- URL: **http://www.patton.com**

**Note** Packages received without an RMA number will not be accepted.



- **This device contains no user serviceable parts. The equipment shall be returned to Patton Electronics for repairs, or repaired by qualified service personnel.**
- **The external power adapter shall be a listed Limited Power Source. Ensure that the power cable used meets all applicable standards for the country in which it is to be installed, and that it is connected to a wall outlet which has earth ground. The mains outlet that is utilized to power the device shall be within 10 feet (3 meters) of the device, shall be easily accessible, and protected by a circuit breaker.**
- **Do not work on the system or connect or disconnect cables during periods of lightning activity.**



The Interconnecting cables shall be acceptable for external use and shall be rated for the proper application with respect to voltage, current, anticipated temperature, flammability, and mechanical serviceability



In accordance with the requirements of council directive 2002/96/EC on Waste of Electrical and Electronic Equipment (WEEE), ensure that at end-of-life you separate this product from other waste and scrap and deliver to the WEEE collection system in your country for recycling.

## 2.0 GENERAL INFORMATION

Thank you for your purchase of this Patton Electronics product. This product has been thoroughly inspected and tested and is warranted for one year for parts and labor. If any questions or problems arise during installation or use of this product, contact Patton Electronics Technical Support at +1 (301) 975-1007.

### 2.1 FEATURES

- Easy to install standalone VLINK modems (no configuration required)
- Auto-MDIX Ethernet
- Auto-sensing full or half-duplex Ethernet
- Auto-sensing 10/100Base-TX
- Extends network connections up to 6,000 ft (1.83 km) over 2-wire 24-AWG unconditioned lines
- Switch selectable line rates up to 16.67 Mbps
- 7 symmetric or asymmetric settings via DIP switch
- POTS/ISDN splitter on board
- Transparent operation
- LED indicators for Power, Ethernet Link & Activity, VLINK link & Quality of Line (QOL)
- Surge suppression up to 20 kA (8/20  $\mu$ s)

- Available in rack-mount or standalone configurations
- Made in the USA

## 2.2 DESCRIPTION

The Patton Electronics VLINK/CO and VLINK/CP VDSL modems provide high-speed LAN connections between peered Ethernet LANs, remote PCs, or any other network enabled 10/100Base-T device.

Operating in pairs, a VLINK/CO (central office) located at one end of the LAN extension and a VLINK/CP (customer premise) at the other end, these units can automatically forward LAN broadcasts, multicasts, and frames across a 2-wire voice-grade twisted-pair link. The data is passed transparently (unmodified) through the VLINK modems. The VLINK modems automatically add and delete MAC addresses, only passing packets across the VDSL link that are meant for the remote peered LAN.

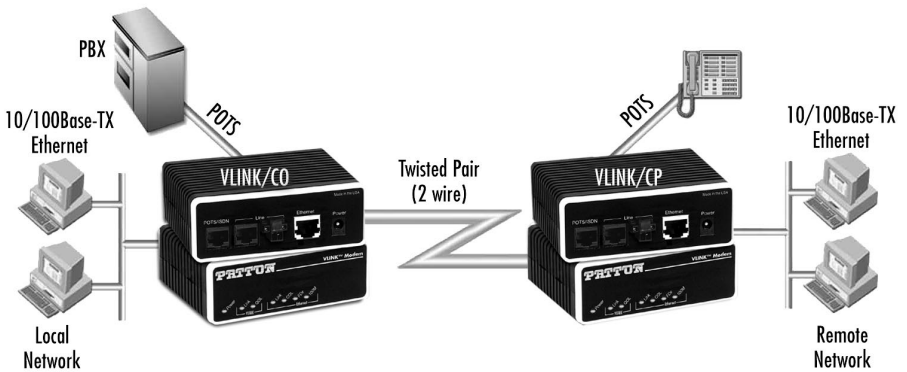

Figure 1. Typical application

The VLINK/CO modem and VLINK/CP modem work together to create a transparent extension between two peered Ethernet LANs. POTS/ISDN calls can be made over a VDSL link without interfering with the data. Figure 1 shows a typical point-to-point application.

## 3.0 INSTALLATION

Because the VLINK modem requires no configuration, it can be installed quickly. If you are installing a standalone unit, refer to section 3.1 "Standalone unit installation". Otherwise, refer to section 3.2 "Rack card installation".

**Note** If asymmetric transmission or line rates other than 12.5 Mbps are required, refer to section 4.0, "Configuration" on page 13.

### 3.1 STANDALONE UNIT INSTALLATION

Do the following:

1. Connect the line interface between the units (refer to section 3.3, "Connecting the Twisted-Pair Line Interface" on page 10)

**Note** See Figure 2 for the standalone unit's rear panel arrangements.

2. Connect the Ethernet interface (refer to section 3.4, "Connecting the 10/100Base-T Ethernet Interface" on page 11).
3. Connect the power plug (refer to section 3.6, "Connecting Power" on page 12).

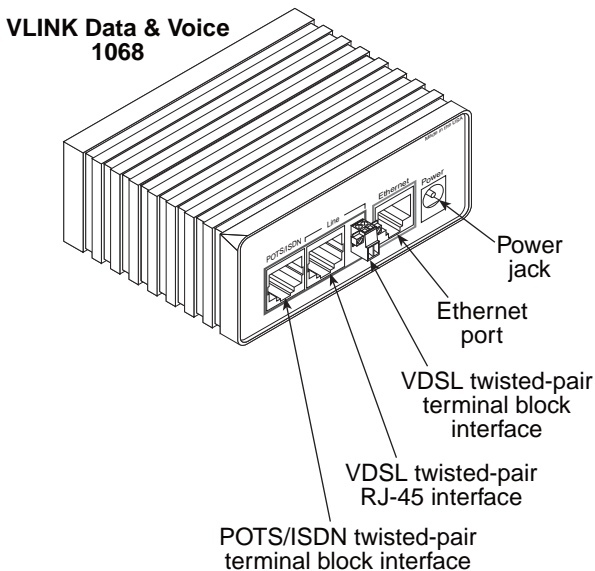

**Figure 2.** VLINK modem standalone rear panel

**Note** The VDSL twisted-pair terminal block interface is included on Model 1068DV/TB45 only.



## 3.2 RACK CARD INSTALLATION

The VLINK modem rack card comprised a front card and a rear card. Do the following to install the cards into the rack chassis:

1. Slide the rear card into the back of the chassis along the metal rails.
2. Secure the rear card using the supplied metal screws.
3. Slide the front card into the chassis until you feel resistance as the front card engages the rear card. When that happens, *gently* push the front card forward until it is fully seated in the card-edge receptacle of the rear card (it should *click* into place).
4. Secure the front card using the captive fasteners.

**Note** The Model 1001R14 chassis supports “hot swapping” of cards, so it is not necessary to power down the rack when you install or remove a VLINK modem rack card.

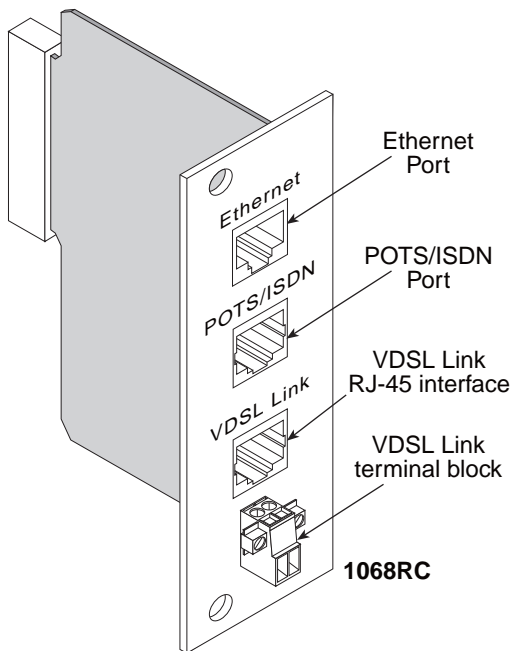

Figure 3. VLINK modem rack card

5. Connect the line interface between the units (refer to section 3.3, “Connecting the Twisted-Pair Line Interface” on page 10)

**Note** See Figure 3 for the rack card’s panel arrangements.

6. Connect the Ethernet interface (refer to section 3.4, "Connecting the 10/100Base-T Ethernet Interface" on page 11).

### 3.3 CONNECTING THE TWISTED-PAIR LINE INTERFACE

The VLINK modem supports communication between two peer Ethernet LAN sites over a distance of up to 6,000 ft (1.83 km) over 24 AWG (0.5 mm) twisted-pair wire.

**Note** Actual distance and link performance may vary depending on the environment and type/gauge of wire used.

Follow the steps below to connect the VLINK modem VDSL interfaces.

**Note** The VLINK modem units work in pairs. One of the units must be a CO (Central Office), and the other unit must be a CP (Customer Premise). It does not matter which end is the CO and which is the CP. The link is always initiated by the CP. As long as the CO is powered on, the CP can establish a link by being powered on or by having its power reset.

1. To function properly, the two VLINK modems must be connected together using twisted-pair, unconditioned, dry, metal wire, between 19 (0.9mm) and 26 AWG (0.4mm). Leased circuits that run through signal equalization equipment are not acceptable.
2. The VLINK modem is equipped with two interface jacks that can be used on the VDSL interface, an RJ-45 or a terminal block. These VDSL interfaces are a two-wire interface. Observe the signal/pin relationships on the VLINK modem's VDSL interface jacks.

The **RJ-45 connector** on the VLINK modem's twisted pair interface is **polarity insensitive** and is wired for a two-wire interface. The signal/pin relationship is shown in Figure 4.

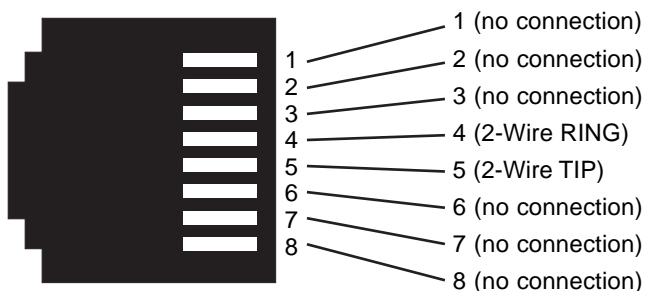

**Figure 4.** VLINK modem (RJ-45) twisted pair line interface.

The **terminal block connector** on the VLINK modem's twisted pair interface is **polarity insensitive** and is wired for a two-wire interface. The signal/pin relationships is shown in Figure 5.

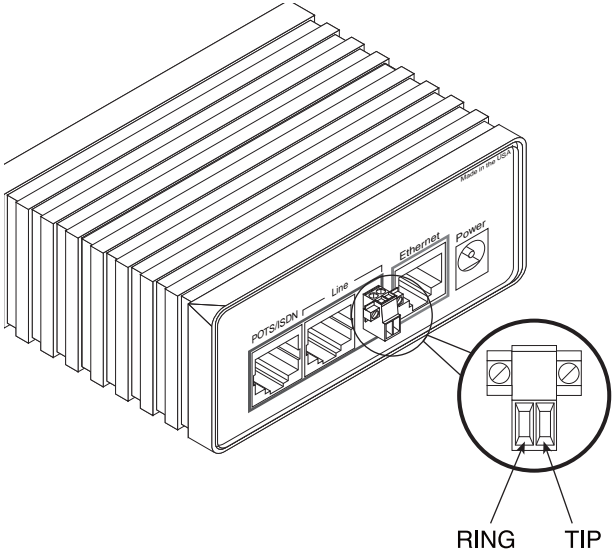

**Figure 5.** VLINK modem (terminal block version) twisted pair line interface (Model 1068DV/TB45)

### 3.4 CONNECTING THE 10/100BASE-T ETHERNET INTERFACE

The unshielded RJ-45 port labeled *Ethernet* is the Auto-MDIX10/100Base-T interface. This port is designed to connect directly to a 10/100Base-T network. Figure 6 shows the signal/pin relationships on this interface. You may connect this port to a hub or PC using a straight through or crossover cable that is up to 328 ft long.

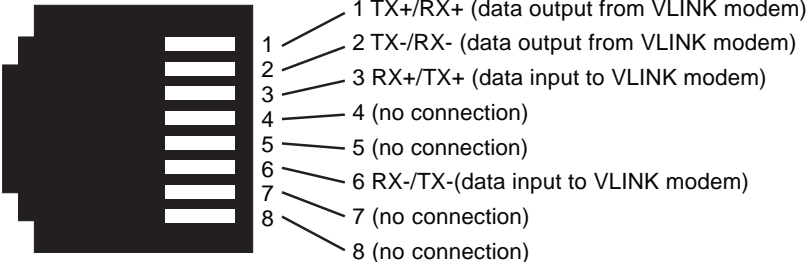

**Figure 6.** VLINK modem 10/100Base-T RJ-45 Connector Pinout.

### 3.5 CONNECTING THE POTS/ISDN LINE

The RJ-45 port labeled "POTS/ISDN" is the POTS/ISDN interface. A telephone or an ISDN device may be connected to this port and carried over the VDSL line. The units do not need power for the POTS interface to work. The RJ-45 connector in the VLINK modem's POTS/ISDN interface is wired as shown in Figure 7.

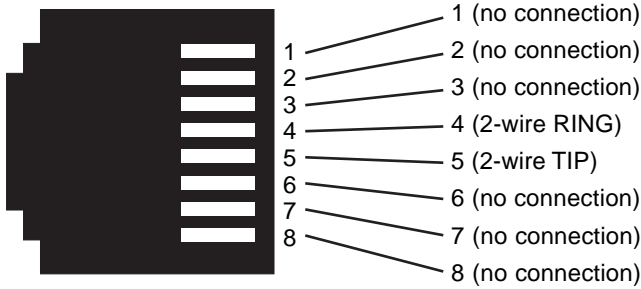

Figure 7. VLINK (RJ-45) POTS/ISDN interface

### 3.6 CONNECTING POWER

An external AC or DC power supply is available separately. This connection is made via the barrel jack on the rear panel of the VLINK standalone modem. No configuration is necessary for the power supply (See Appendix B for domestic and international power supply and cord options).

DC power (supplied via the power supply jack to the VLINK modem) must meet the following requirements; DC power supplied must be regulated +5VDC  $\pm 5\%$ , 1.0A minimum. Center pin is +5V. The barrel type plug has a 2.5/5.5/10mm I.D./O.D./Shaft Length dimensions.

The VLINK modem does not have a power switch, so it powers up as soon as it is plugged in.



**WARNING**

**There are no user-serviceable parts in the VLINK modem. Fuse replacement should only be performed by qualified service personnel. Contact Patton Electronics Technical support at (301) 975-1007 for more information.**

## 4.0 CONFIGURATION

The Model 1068 VLINK modem has eight DIP switches for configuring the unit for a wide variety of applications. This section describes switch locations and explains the different configurations. No dip switch options are available on the 1058.

### 4.1 CONFIGURING THE HARDWARE DIP SWITCHES

Using a small flat-tip screwdriver, remove the protective cover located on the underside of the VLINK modem (see Figure 8).

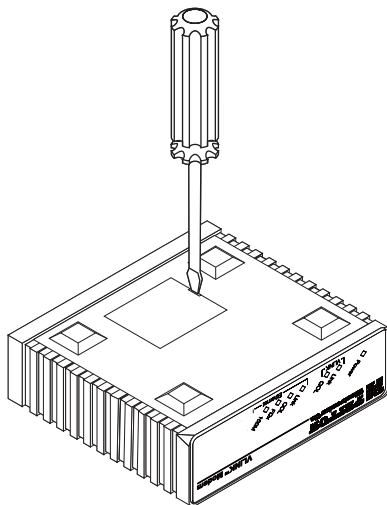
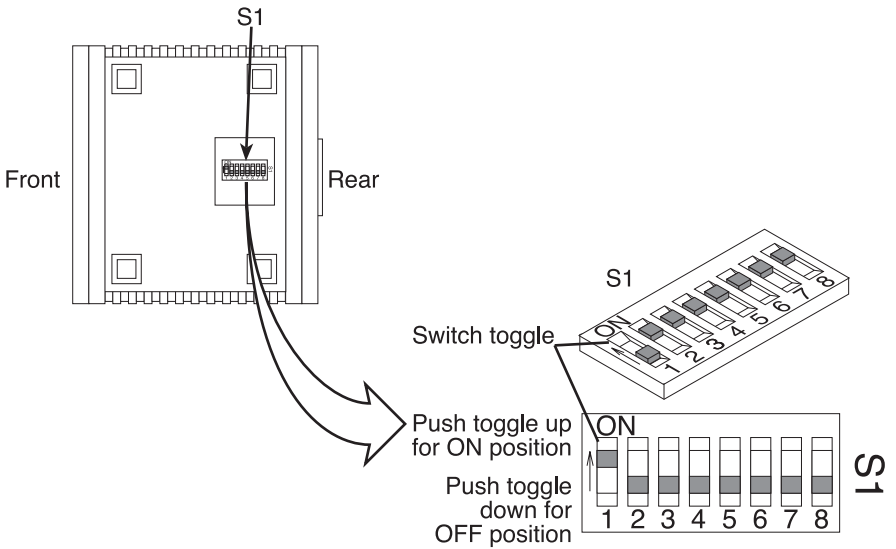
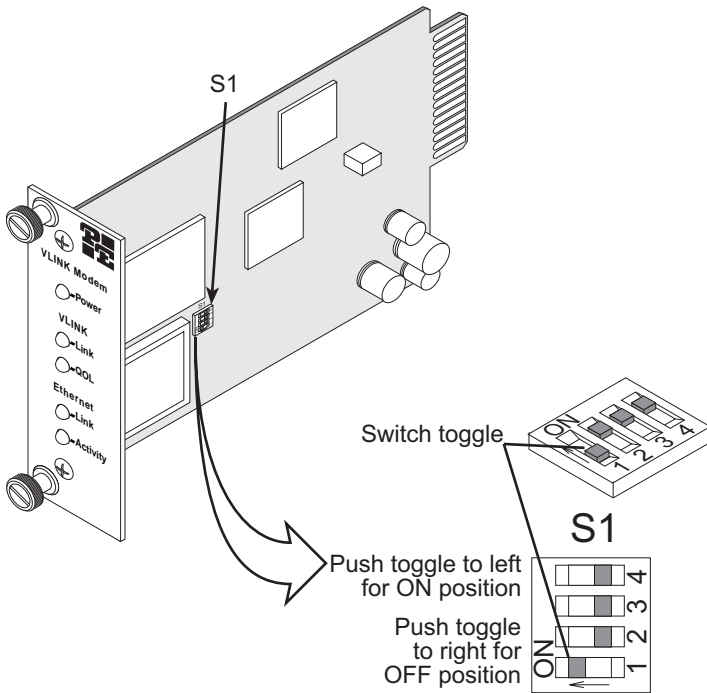

Figure 8. Removing protective cover

Figure 9 and Figure 10 on page 14 show the orientation of the DIP switches in the On and Off positions.



**Figure 9.** Model 1068 standalone modem DIP switch orientation



**Figure 10.** Model 1068 rack card DIP switch orientation

## 4.2 CONFIGURING DIP SWITCH S1

DIP switch S1 is where you configure the VDSL line rate, symmetric or asymmetric, Ethernet full auto negotiation capability (100Base-T full or half duplex, 10Base-T full or half duplex) or limited auto sense (only 100Base-T half duplex, 10Base-T full or half duplex).

### Switch S1-1: Ethernet Auto Sense

Use switch S1-1 to configure the unit for full auto sense capability or limited auto sense capability. Full Auto sense capability consists of standard Ethernet Auto sensing (100BaseT full duplex, 100BaseT half duplex, 10BaseT full duplex, and 10BaseT half duplex). Limited Auto sensing capability consists on only auto sensing for 100BaseT half duplex, 10BaseT full duplex, and 10BaseT half duplex. The limited auto negotiation feature is used when an Ethernet device does not comply with IEEE 802.3x (back pressure flow control) at 100M full duplex.

**Table 1:** Ethernet Auto Negotiation Selection Chart

S1-1	Setting
OFF	Full Auto Negotiation (Factory Default) (100 Mbps, Full or Half Duplex) (10 Mbps, Full or Half Duplex)
ON	Limited Auto Negotiation (100 Mbps Half Duplex) 10 Mbps Full or Half Duplex)

### Switches S1-2 and S1-4: Data Rate

Use switches S1-2 and S1-4 to configure the VDSL line rates.

**Table 2:** Symmetric VDSL Line Rates Selection Chart

S1-2	S1-3	S1-4	Symmetric Line Rate
ON	ON	ON	6.25 Mbps
ON	ON	OFF	9.38 Mbps
ON	OFF	OFF	12.5 Mbps (Factory Default)*
ON	OFF	ON	16.67 Mbps

\*. Model 1058 only has one symmetric line rate setting, which is 12.5 Mbps.

**Table 3:** Model 1068 Asymmetric VDSL Line Rates Selection Chart

<b>S1-2</b>	<b>S1-3</b>	<b>S1-4</b>	<b>Asymmetric Line Rates DS/US*</b>
OFF	OFF	ON	4.17 Mbps/1.56 Mbps
OFF	ON	ON	9.38 Mbps/1.56 Mbps
OFF	ON	OFF	16.67 Mbps/2.34 Mbps

\*. DS = downstream, US = upstream

**Note** Table 3 only applies to Model 1068.

**Table 4:** Reserved for future use

<b>S1-5</b>	<b>S1-6</b>	<b>S1-7</b>	<b>S1-8</b>	<b>Reserved for future use</b>
OFF	OFF	OFF	OFF	Reserved (Factory Default)



## 5.0 OPERATION

Once the VLINK modems are properly installed, they should operate transparently. No user settings required. This section describes reading the LED status monitors.

### 5.1 POWER UP

Before applying power to the VLINK modem, please review section 3.6, "Connecting Power" on page 12 to verify that the unit is connected to the appropriate power source.



**WARNING**

**There are no user-serviceable parts in the VLINK modem. Fuse replacement should only be performed by qualified service personnel. Contact Patton Electronics Technical support at (301) 975-1007 for more information.**

### 5.2 FRONT PANEL LED STATUS MONITORS

The VLINK modem features nine front panel LEDs (five on the rack card) that monitor power, the Ethernet signals, and the VDSL connection. Figure 11 (standalone version) and Figure 12 on page 19 (rack card version) show the front panel LEDs. Table 5 on page 18 describes the LED functions for the standalone model, Table 6 on page 19 describes the LED functions for the rack card.

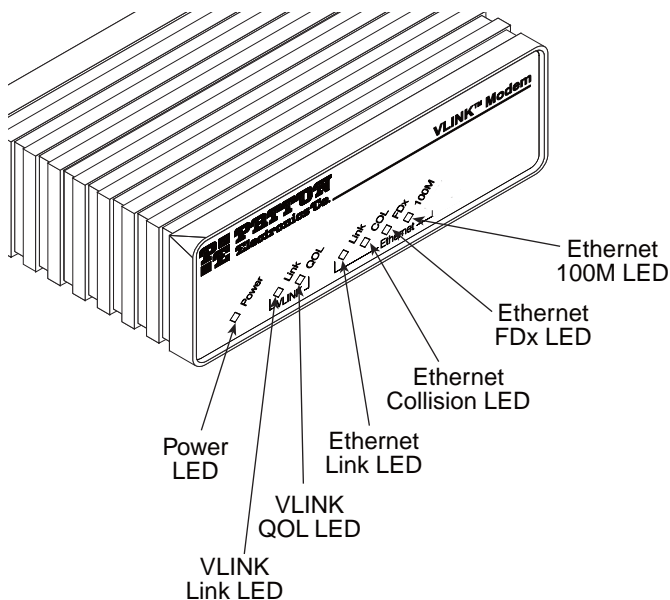

**Figure 11.** VLINK modem standalone unit front panel

**Table 5:** Front panel LED description for standalone modem

LED	Description
Power	<b>On (green)</b> when power is applied to the unit. <b>Off</b> when no power is applied to the unit.
VLINK - Link	<b>On (green)</b> when the end-to-end VDSL link between the units is established. <b>Off</b> when the link has not been established or when the link fails
VLINK - QOL	<b>Flashes yellow</b> at different rates to indicate the amount of error correction taking place on data passing over the VDSL link. This is a normal operating condition and all data is passing correctly over the link even if the link is <b>solidly yellow</b> . However, if the LED is <b>solid yellow</b> and the <b>VLINK Link LED is Off</b> , <b>Off</b> when no power is applied to the unit.
Ethernet - Link	<b>On (green)</b> when the 10/100Base-T Ethernet link has been established. <b>Off</b> when the 10/100Base-T Ethernet link has not been established or when the link fails. Flashes when there is Ethernet activity.
Ethernet - COL (Collision)	<b>Flashes yellow</b> to indicate Ethernet collisions are occurring.
Ethernet - FDx (Duplex)	<b>On (yellow)</b> when in full-duplex Ethernet mode. <b>Off</b> when when operating in half-duplex Ethernet mode.
Ethernet - 100M	<b>On (yellow)</b> when the link has not been established or when operating in 100-Mbps Ethernet mode. <b>Off</b> when operating in 10-Mbps Ethernet mode.

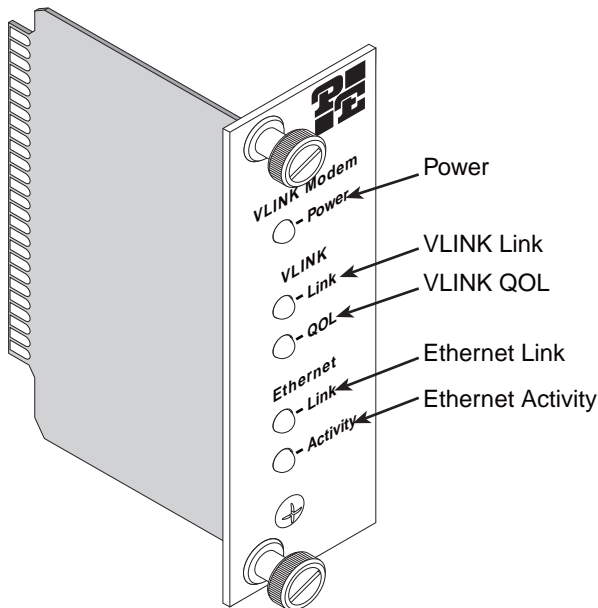

**Figure 12.** VLINK modem rack card front panel

**Table 6:** Front panel LED description for rack card modem

LED	Description
Power	Solid GREEN to indicate the unit is powered on.
VLINK modem Link	(Active Green) Solid green (ON) to indicate that the end-to-end VDSL link between the VLINK modems is established. The VLINK modem LED is OFF when the link is down.
VLINK modem QOL	(Active Yellow) Flashes YELLOW to indicate the processor is correcting an error in the data thus preventing the transmission of corrupted data to the Ethernet port. The more error corrections, the more often the LED blinks. If the light remains lit continuously, it means that the VDSL line is noisy—although the data at the Ethernet port remains uncorrupted. Further impairment of the line however, risks having the line fail, as indicated by the green VLINK modem Link LED extinguishing.
Ethernet Link	(Active Green) Solid Green indicates that 10/100Base-T Ethernet link has been established.
Ethernet Activity	(Active Yellow) Flashes yellow to indicate Ethernet activity on the VLINK modem's 10/100Base-T Ethernet port.

## **APPENDIX A**

### **SPECIFICATIONS**

#### **A.1 LAN CONNECTION**

- Unshielded RJ-45, 10/100Base-T, IEEE 802.3 Ethernet
- VDSL Connection: RJ-45 and Terminal Block

#### **A.2 TRANSMISSION LINE**

Two-wire unconditioned twisted pair.

#### **A.3 VDSL LINE RATE**

16.67 Mbps (Model 1068 only) and 12.55 Mbps (Model 1058) symmetric upstream/downstream. Additional symmetric and asymmetric rates are available via DIP switch settings:

- Model 1058 - Symmetric Line Rate: 12.5 Mbps
- Model 1068 - Symmetric Line Rates:  
6.25 Mbps, 9.38 Mbps, 12.5 Mbps, 16.67 Mbps
- Model 1068 - Asymmetric Line Rates:  
4.17 Mbps/1.56 Mbps, 9.38 Mbps/1.56 Mbps, 16.67 Mbps/2.34 Mbps

#### **A.4 VDSL DISTANCE**

6,000 ft (1.83 km) at 1.56 Mbps upstream/4.17 Mbps downstream

**Note** Distances depend on selected line rate.

#### **A.5 VDSL SURGE SUPPRESSOR**

Gas tube with maximum current surge: 20 kA (8/20  $\mu$ s).

#### **A.6 LED STATUS INDICATORS**

- Power (Green)
- VDSL: Link (Green) & QOL (Red)
- Ethernet: Link (Green), Collision (Yellow), Duplex (Yellow), and 10/100M (Yellow)

#### **A.7 POWER SUPPLY**

Input power: 5 VDC, 1A

Power consumption: 560mA at 5 VDC (typical)

External AC and DC options:

- AC: 120 VAC, 220 VAC, and UI (120–240 VAC)
- DC: 12 VDC, 24 VDC and 48 VDC

### **A.8 TEMPERATURE RANGE**

32–122°F (0–50°C)

### **A.9 HUMIDITY**

Up to 90% non-condensing.

### **A.10 DIMENSIONS**

1.58H x 4.16W x 3.75D in. (10.6H x 4.1W x 8.8D cm)

**APPENDIX B**  
**MODEL 1068 SERIES FACTORY**  
**REPLACEMENT PARTS AND ACCESSORIES**

Patton Model #	Description
<b>Base Models</b>	
1068DVRC/CO	CO Variable Rate VDSL RC CO Rack Card; voice and data
1068DVRC/CP	CP Variable Rate VDSL CP Rack Card; voice and data
1058DVRC/CO	CO Fixed 12.5Mbps VDSL RC CO Rack Card; voice and data
1058DVRC/CP	CP Fixed 12.5Mbps VDSL CP Rack Card; voice and data
1068DV/CO/E	CO Variable Rate VDSL CO Modem, voice & data, no power supply
1068DV/CP/E	CP Variable Rate VDSL CP Modem, voice & data, no power supply
1068DV/E-2PK	Variable Rate VDSL Modem Kit: includes one central office (CO) and one customer premise (CP) VLINK modem, voice & data, no power supply
1068DV/CO/EUI	CO Variable Rate VDSL CO Modem, voice and data, 120-240VAC
1068DV/CP/EUI	CP Variable Rate VDSL CP Modem, voice and data, 120-240VAC
1068DV/EUI-2PK	Variable Rate VDSL Modem Kit: includes one central office (CO) and one customer premise (CP) VLINK modem, voice and data, 120-240VAC
1068DV/CO/TB45/EUI	Variable Rate VDSL CO Modem, voice and data, TB and RJ45; 120-240VAC
1068DV/CP/TB45/EUI	Variable Rate VDSL CP Modem, voice and data, TB and RJ45; 120-240VAC
1068DV/CP/TB45/EUI-2PK	Variable Rate VDSL Modem Kit: includes one central office (CO) and one customer premise (CP) VLINK modem, voice and data, TB and RJ45; 120-240VAC
1058DV/CO/E	CO Fixed 12.5Mbps VDSL CO Modem, voice & data, no power supply
1058DV/CP/E	CP Fixed 12.5Mbps VDSL CP Modem, voice & data, no power supply
1058DV/E-2PK	Fixed 12.5Mbps VDSL Modem Kit: includes one central office (CO) and one customer premise (CP) VLINK modem, voice & data, no power supply
1058DV/CO/EUI	CO Fixed 12.5Mbps VDSL CO Modem, voice and data, 120-240VAC
1058DV/CP/EUI	CP Fixed 12.5Mbps VDSL CP Modem, voice and data, 120-240VAC
1058DV/EUI-2PK	Fixed 12.5Mbps VDSL Modem Kit: includes one central office (CO) and one customer premise (CP) VLINK modem, voice and data, 120-240VAC
07M1068-UM	User Manual
<b>Power Supplies</b>	
08055DCUI	100-240VAC (+5V reg. DC/2A) Universal Input Adapter.
08055-120-5-1	120 VAC (+5V reg. DC/1A) Input Adapter
12V-PSM	12 VDC Input Adapter
24V-PSM	24 VDC Input Adapter

<b>Patton Model #</b>	<b>Description</b>
48V-PSM	48 VDC Input Adapter
<b>Power Cords*</b>	
0805US	American Power Cord
0805EUR	European Power Cord CEE 7
0805UK	United Kingdom Power Cord
0805AUS	Australian Power Cord
0805DEN	Denmark Power Cord
0805FR	France/Belgium Power Cord
0805IN	India Power Cord
0805IS	Israel Power Cord
0805JAP	Japan Power Cord
0805SW	Switzerland Power Cord

\*Only required with optional UI power supply (08055DCUI)

## **APPENDIX C**

### **VLINK SERIES INTERFACE PIN ASSIGNMENT**

#### **C.1 10/100BASE-T INTERFACE**

##### **RJ-45**

- Pin 1: TX+/RX+
- Pin 2: TX-/RX-
- Pin 3: RX+/TX+
- Pin 6: RX-/TX-
- Pins 4, 5, 7, 8: no connection

#### **C.2 VDSL INTERFACE**

##### **RJ-45**

- Pin 4: RING
- Pin 5: TIP
- Pins 1, 2, 3, 6, 7, 8: no connection

##### **Terminal Block (1068DV/TB45 Only)**

See Figure 5 on page 11.

#### **C.3 POTS/ISDN INTERFACE**

##### **RJ-45**

- Pin 4: 2-wire RING
- Pin 5: 2-wire TIP
- Pins 1, 2, 3, 6, 7, 8: no connection



## APPENDIX D

DISTANCE CHART, BASED ON 24 AWG (0.5 MM)

Symm Line Rate	Distance in feet (km)
6.25 Mbps	4,500 (1.37)
9.38 Mbps	4,150 (1.26)
*12.5 Mbps	4,000 (1.22)
16.67 Mbps	3,300 (1.00)

\*. This is the only option available for Model 1058.

Asymm Line Rate (DS/US)	Distance in feet (km)
4.17 Mbps/1.56 Mbps	6,000 (1.83)
9.38 Mbps/1.56 Mbps	5,500 (1.68)
16.67 Mbps/2.34 Mbps	5,000 (1.52)

**Note** DS/US = Downstream/Upstream.



Copyright © 2006  
Patton Electronics Company  
All Rights Reserved.

## Free Manuals Download Website

<http://myh66.com>

<http://usermanuals.us>

<http://www.somanuals.com>

<http://www.4manuals.cc>

<http://www.manual-lib.com>

<http://www.404manual.com>

<http://www.luxmanual.com>

<http://aubethermostatmanual.com>

Golf course search by state

<http://golfingnear.com>

Email search by domain

<http://emailbydomain.com>

Auto manuals search

<http://auto.somanuals.com>

TV manuals search

<http://tv.somanuals.com>