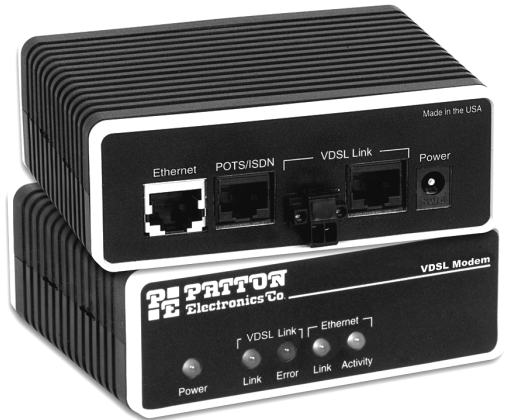


# USER MANUAL

---

## MODEL 1058 VDSL Modem



**PATTON**  
**Electronics Co.**



Part# 07M1058-A  
Doc# 058091UA  
Revised 10/12/01

SALES OFFICE  
(301) 975-1000  
TECHNICAL SUPPORT  
(301) 975-1007

An ISO-9001 Certified  
Company

Download from [Www.Somanuals.com](http://www.Somanuals.com). All Manuals Search And Download.

<b>1.0</b>	<b>Warranty Information .....</b>	<b>3</b>
1.1	Radio and TV Interference.....	3
1.2	CE Notice.....	4
1.3	Service.....	4
<b>2.0</b>	<b>General Information.....</b>	<b>5</b>
2.1	Features.....	5
2.2	Description.....	5
<b>3.0</b>	<b>Installation.....</b>	<b>7</b>
3.1	Connecting the Twisted-Pair Line Interface .....	7
3.2	Connecting the 10/100Base-T Ethernet Interface .....	9
	Connecting the 10/100Base-T Ethernet Port to a Hub.....	9
	Connecting the 10/100Base-T Ethernet Port to a PC (DTE).....	10
3.3	Connecting the POTS/ISDN line.....	10
3.4	Connecting Power .....	11
<b>4.0</b>	<b>Operation.....</b>	<b>12</b>
4.1	Power Up.....	12
4.2	Front Panel LED Status Monitors .....	12
<b>A</b>	<b>Specifications .....</b>	<b>14</b>
A.1	LAN Connection .....	14
A.2	Transmission Line .....	14
A.3	VDSL Line Rate .....	14
A.4	Actual Data Rate .....	14
A.5	VDSL Distance .....	14
A.6	VDSL Surge Suppressor .....	14
A.7	LED Status Indicators .....	14
A.8	Power Supply .....	14
A.9	Temperature Range .....	14
A.10	Humidity .....	14
A.11	Dimensions .....	14
<b>B</b>	<b>Model 1058 Series Factory Replacement Parts and Accessories.....</b>	<b>15</b>
<b>C</b>	<b>Model 1058 Series Interface Pin Assignment .....</b>	<b>16</b>
C.1	10/100Base-T Interface: .....	16
	RJ-45.....	16
C.2	VDSL Interface: .....	16
	RJ-45.....	16
	Terminal Block.....	16
C.3	POTS/ISDN Interface: .....	16
	RJ-45.....	16

## 1.0 WARRANTY INFORMATION

**Patton Electronics** warrants all Model 1058 components to be free from defects, and will—at our option—repair or replace the product should it fail within one year from the first date of the shipment.

This warranty is limited to defects in workmanship or materials, and does not cover customer damage, abuse or unauthorized modification. If this product fails or does not perform as warranted, your sole recourse shall be repair or replacement as described above. Under no condition shall **Patton Electronics** be liable for any damages incurred by the use of this product. These damages include, but are not limited to, the following: lost profits, lost savings and incidental or consequential damages arising from the use of or inability to use this product. **Patton Electronics** specifically disclaims all other warranties, expressed or implied, and the installation or use of this product shall be deemed an acceptance of these terms by the user.

### 1.1 RADIO AND TV INTERFERENCE

The Model 1058 generates and uses radio frequency energy, and if not installed and used properly—that is, in strict accordance with the manufacturer's instructions—may cause interference to radio and television reception. The Model 1058 has been tested and found to comply with the limits for a Class A computing device in accordance with specifications in Subpart B of Part 15 of FCC rules, which are designed to provide reasonable protection from such interference in a commercial installation. However, there is no guarantee that interference will not occur in a particular installation. If the Model 1058 does cause interference to radio or television reception, which can be determined by disconnecting the unit, the user is encouraged to try to correct the interference by one or more of the following measures: moving the computing equipment away from the receiver, re-orienting the receiving antenna and/or plugging the receiving equipment into a different AC outlet (such that the computing equipment and receiver are on different branches).

## 1.2 CE NOTICE

The CE symbol on your Patton Electronics equipment indicates that it is in compliance with the Electromagnetic Compatibility (EMC) directive and the Low Voltage Directive (LVD) of the European Union (EU). A Certificate of Compliance is available by contacting Technical Support.



**Caution**

**This device is not intended to be connected to the public telephone network.**

**Note** The Model 1058DV is currently awaiting Part 68 approval.

## 1.3 SERVICE

All warranty and nonwarranty repairs must be returned freight prepaid and insured to Patton Electronics. All returns must have a Return Materials Authorization number on the outside of the shipping container. This number may be obtained from Patton Electronics Technical Services at:

- Tel: **+1 (301) 975-1007**
- Email: **support@patton.com**
- URL: **http://www.patton.com**

**Note** Packages received without an RMA number will not be accepted.

## 2.0 GENERAL INFORMATION

Thank you for your purchase of this Patton Electronics product. This product has been thoroughly inspected and tested and is warranted for one year for parts and labor. If any questions or problems arise during installation or use of this product, contact Patton Electronics Technical Support at +1 (301) 975-1007.

### 2.1 FEATURES

- Easy to install standalone VDSL modems—*no configuration required*
- Auto-sensing full or half-duplex Ethernet
- Auto-sensing 10/100Base-T
- Extends network connections up to 4,652 ft (1,418 m) over 2-wire 24-AWG unconditioned lines
- 12.5 Mbps symmetric line rate; 10 Mbps data rate
- POTS/ISDN splitter on board
- Transparent operation
- LED indicators for Power, Ethernet Link & Activity, VDSL Link & Error
- Surge suppression up to 20 kA (8120  $\mu$ s)
- Available in rack-mount or standalone configurations
- Made in the USA

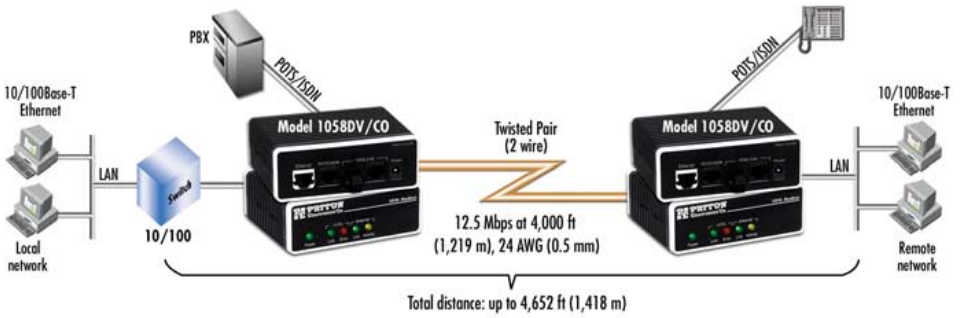
### 2.2 DESCRIPTION

The Patton Electronics Model 1058/CO\* and 1058/CP VDSL\* modems provide high-speed LAN connections between peered Ethernet LANs, remote PC's, or any other network enabled 10/100Base-T device.

Operating in pairs with a Model 1058/CO (central office) located at one end of the LAN extension and a Model 1058/CP (customer premise) at the other end, these units can automatically forward LAN broadcasts, multicasts, and frames across a 2-wire twisted pair link. The data is passed transparently (that is, unmodified) through the 1058s. What's more, the 1058s automatically add and delete MAC addresses, only passing packets across the VDSL link that are meant for the remote peered LAN.

---

\* Only Models 1058DV/CO and 1058DV/CP have POTS/ISDN splitters on board.



**Figure 1.** Typical application

The 1058DV/CO and 1058DV/CP work together to create a transparent extension between two peered Ethernet LANs. POTS/ISDN calls can be made over the VDSL link without interfering with the data. Figure 1 shows a typical point-to-point application.

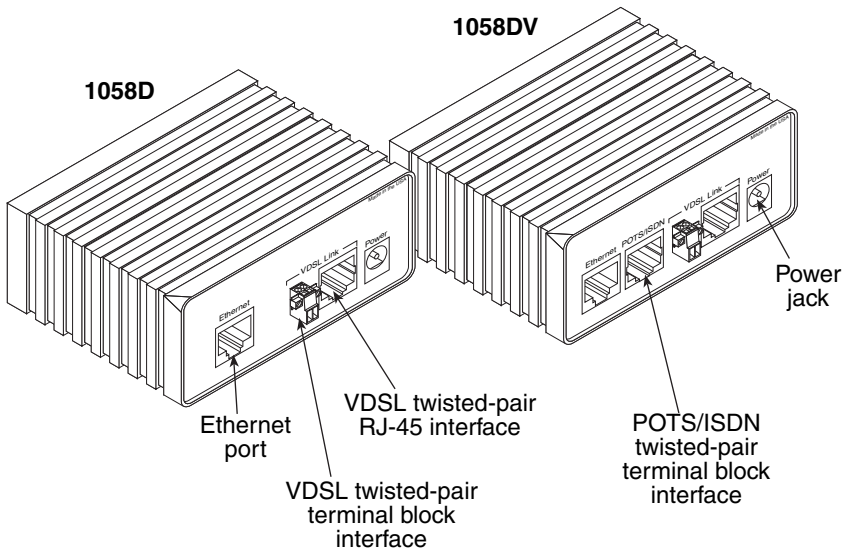
### 3.0 INSTALLATION

Because the Model 1058 requires no configuration, it can be installed and made operational quickly. Installation takes place as follows:

1. Connecting the line interface between the units (refer to section 3.1, “Connecting the Twisted-Pair Line Interface” on page 7)

**Note** See Figure 2 for the rear panel arrangements.

2. Connecting the Ethernet interface (refer to section 3.2, “Connecting the 10/100Base-T Ethernet Interface” on page 9).
3. Connecting the power plug (refer to section 3.4, “Connecting Power” on page 11).



**Figure 2.** Model 1058 standalone rear panel

#### 3.1 CONNECTING THE TWISTED-PAIR LINE INTERFACE

The Model 1058 supports communication between two peer Ethernet LAN sites over a distance of up to 4,652 ft (1,418 m) over 24 AWG (0.5 mm) twisted-pair wire.

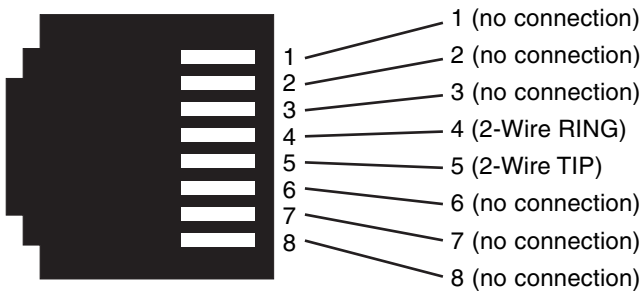
**Note** Actual distance and link performance may vary depending on the environment and type/guage of wire used.

Follow the steps below to connect the Model 1058 VDSL Interfaces.

**Note** The Model 1058 units work in pairs. One of the units must be a Model 1058/CO (Central Office), and the other unit must be a Model 1058/CP (Customer Premise). It does not matter which end is the 1058/CO and which is the 1058/CP. The link is always initiated by the 1058/CP. As long as the 1058/CO is powered on, the 1058/CP can establish a link by being powered on or by having its power reset.

1. To function properly, the two Model 1058's must be connected together using twisted-pair, unconditioned, dry, metal wire, between 19 (0.9mm) and 26 AWG (0.4mm). Leased circuits that run through signal equalization equipment are not acceptable.
2. The Model 1058 is equipped with two interface jacks that can be used on the VDSL interface, an RJ-45 or a terminal block. These VDSL interfaces are a two-wire interface. Observe the signal/pin relationships on the Model 1058's VDSL interface jacks.

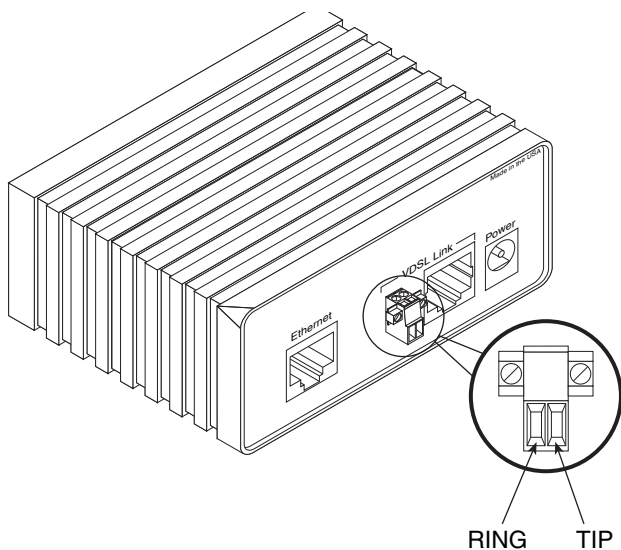
The RJ-45 connector on the Model 1058's twisted pair interface is polarity insensitive and is wired for a two-wire interface. The signal/pin relationship is shown in Figure 3.



**Figure 3.** Model 1058 (RJ-45) twisted pair line interface.

The terminal block connector on the Model 1058's twisted pair interface is polarity insensitive and is wired for a two-wire interface. The signal/pin relationships is shown in Figure 4.

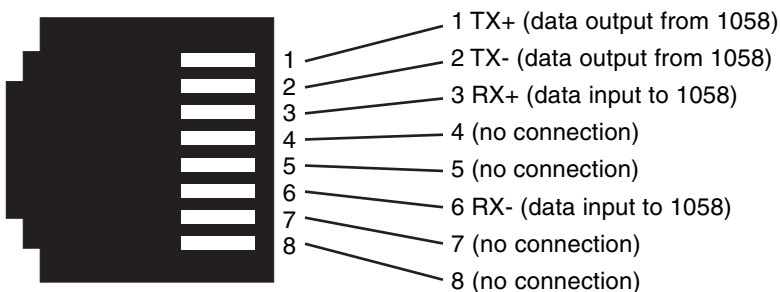




**Figure 4.** Model 1058D (Terminal Block) twisted pair line interface.

### 3.2 CONNECTING THE 10/100BASE-T ETHERNET INTERFACE

The shielded RJ-45 port labeled *Ethernet* is the 10/100Base-T interface. This port is designed to connect directly to a 10/100Base-T network. Figure 5 shows the signal/pin relationships on this interface. You may connect this port to another Ethernet device via a Type 4 or Type 5 cable that is up to 328 ft long.

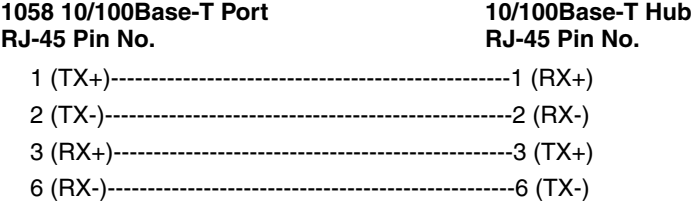


**Figure 5.** Model 1058 10/100Base-T RJ-45 Connector Pinout.

#### Connecting the 10/100Base-T Ethernet Port to a Hub

The Model 1058 10/100Base-T interface is configured as DTE (Data Terminal Equipment), just like a 10/100Base-T network interface card in a PC. Therefore, it "expects" to connect to a 10/100Base-T Hub using a

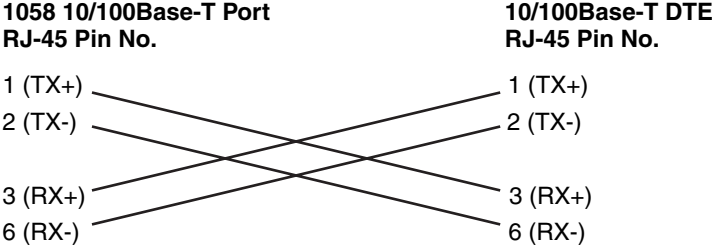
straight-through RJ-45 cable. Figure 6 diagrams the cable wiring for connecting the Model 1058 to a 10/100Base-T hub.



**Figure 6.** Wiring diagram for connecting the Model 1058 to a 10/100Base-T hub

**Connecting the 10/100Base-T Ethernet Port to a PC (DTE)**

The Model 1058 10/100Base-T interface is configured as DTE (Data Terminal Equipment). If you wish to connect the 1058 to another DTE devices such as 10/100Base-T network interface card in a PC (or 1058s in a back-to-back arrangement), you must construct a 10/100Base-T crossover cable as shown in Figure 7.



**Figure 7.** 10/100Base-T crossover cable

**3.3 CONNECTING THE POTS/ISDN LINE**

The RJ-45 port labeled “POTS/ISDN” is the POTS/ISDN interface. A telephone or an ISDN device may be connected to this port and carried over the VDSL line. The units do not need power for the POTS interface to

work. The RJ-45 connector in the model 1058's POTS/ISDN interface is wired as shown in Figure 8.

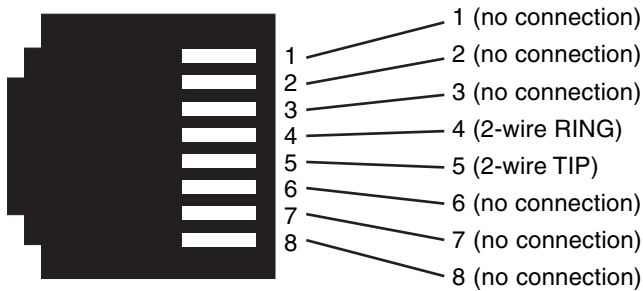


Figure 8. Model 1058DV (RJ-45) POTS/ISDN interface

### 3.4 CONNECTING POWER

An external AC or DC power supply is available separately. This connection is made via the barrel jack on the rear panel of the Model 1058. No configuration is necessary for the power supply (See Appendix B for domestic and international power supply and cord options).

DC power (supplied via the power supply jack to the 1058) must meet the following requirements; DC power supplied must be regulated +5VDC  $\pm$ 5%, 1.0A minimum. Center pin is +5V. The barrel type plug has a 2.5/5.5/10mm I.D./O.D./Shaft Length dimensions.

The Model 1058 does not have a power switch, so it powers up as soon as it is plugged in.

## 4.0 OPERATION

Once the Model 1058s are properly installed, they should operate transparently. No user settings required. This section describes reading the LED status monitors.

### 4.1 POWER UP

Before applying power to the Model 1058, please review section 3.4, "Connecting Power" on page 11 to verify that the unit is connected to the appropriate power source.

### 4.2 FRONT PANEL LED STATUS MONITORS

The Model 1058 features five front panel LEDs that monitor power, the Ethernet signals, and the VDSL Connection. Figure 9 shows the front panel location of each LED. Table 1 on page 13 describes the LED functions.

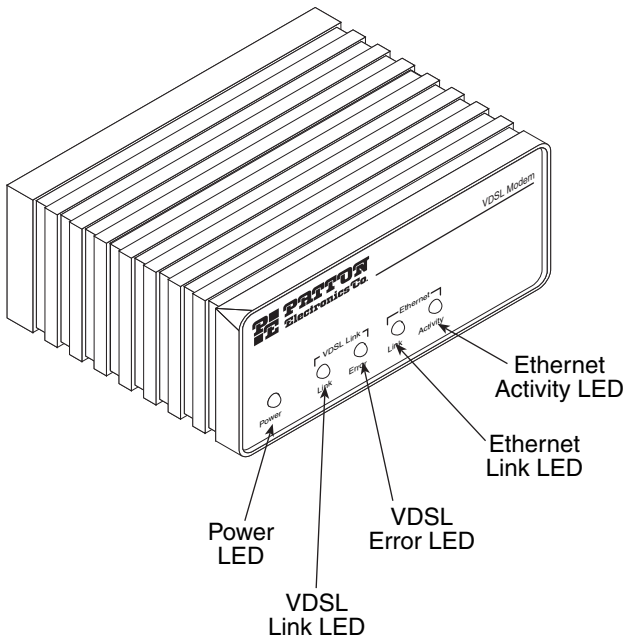


Figure 9. Front panel standalone Model 1058

**Table 1:** Front panel LED description

<b>LED</b>	<b>Description</b>
Power	Solid GREEN to indicate the unit is powered on.
VDSL Link	(Active Green) Solid green (ON) to indicate that the end-to-end VDSL link between the Model 1058s is established. The VDSL LED is OFF when the link is down.
VDSL Error	(Active Red) Flashes Red to indicate errors have occurred on the VDSL link.
Ethernet Link	(Active Green) Solid Green indicates that 10/100Base-T Ethernet link has been established.
Ethernet Activity	(Active Yellow) Flashes yellow to indicate Ethernet activity on the Model 1058's 10/100Base-T Ethernet port.

## **APPENDIX A**

### **SPECIFICATIONS**

#### **A.1 LAN CONNECTION**

- Shielded RJ-45, 10/100Base-T, IEEE 802.3 Ethernet
- VDSL Connection: RJ-45 and Terminal Block

#### **A.2 TRANSMISSION LINE**

Two-wire unconditioned twisted pair

#### **A.3 VDSL LINE RATE**

12.5 Mbps, symmetric upstream/downstream.

#### **A.4 ACTUAL DATA RATE**

10 Mbps, symmetric upstream/downstream.

#### **A.5 VDSL DISTANCE**

4,000 ft (1,219 m)

#### **A.6 VDSL SURGE SUPPRESSOR**

Gas tube with maximum current surge: 20 kA (8120  $\mu$ s)

#### **A.7 LED STATUS INDICATORS**

- Power (Green)
- VDSL: Link (Green) & Error (Red)
- Ethernet: Link (Green) & Activity (Yellow)

#### **A.8 POWER SUPPLY**

External AC and DC options

- AC: 120 VAC, 220 VAC, and UI (120–240 VAC)
- DC: 12 VDC, 24 VDC and 48 VDC

#### **A.9 TEMPERATURE RANGE**

0–50°C

#### **A.10 HUMIDITY**

Up to 90% non-condensing

#### **A.11 DIMENSIONS**

1.58H x 4.16W x 3.75D in. (10.6H x 4.1W x 8.8D cm)

**APPENDIX B**  
**MODEL 1058 SERIES FACTORY**  
**REPLACEMENT PARTS AND ACCESSORIES**

Patton Model #	Description
<b>Base Models</b>	
1058D/CO	CO VDSL Modem, data only, no power supply
1058D/CP	CP VDSL Modem, data only, no power supply
1058D-2PK	VDSL MODEM Kit: includes one central office (CO) and one customer premise (CP) Model 1058, data only, no power supply
1058DV/CO	CO VDSL Modem, voice & data, no power supply
1058DV/CP	CP VDSL Modem, voice & data, no power supply
1058DV-2PK	VDSL MODEM Kit: includes one central office (CO) and one customer premise (CP) Model 1058, voice & data, no power supply
07M1058	User Manual
<b>Power Supplies</b>	
08055DCUI	100-240VAC (+5V reg. DC/2A) Universal Input Adapter.
08055-120-5-1	120 VAC (+5V reg. DC/1A) Input Adapter
12V-PSM	12 VDC Input Adapter
24V-PSM	24 VDC Input Adapter
48V-PSM	48 VDC Input Adapter
<b>Power Cords*</b>	
0805US	American Power Cord
0805EUR	European Power Cord CEE 7
0805UK	United Kingdom Power Cord
0805AUS	Australian Power Cord
0805DEN	Denmark Power Cord
0805FR	France/Belgium Power Cord
0805IN	India Power Cord
0805IS	Israel Power Cord
0805JAP	Japan Power Cord
0805SW	Switzerland Power Cord

\*Only required with optional UI power supply (08055DCUI)

## **APPENDIX C**

### **MODEL 1058 SERIES INTERFACE PIN ASSIGNMENT**

#### **C.1 10/100BASE-T INTERFACE:**

##### **RJ-45**

- Pin 1: TX+
- Pin 2: TX-
- Pin 3: RX+
- Pin 6: RX-
- Pins 4, 5, 7, 8: no connection

#### **C.2 VDSL INTERFACE:**

##### **RJ-45**

- Pin 4: RING
- Pin 5: TIP
- Pins 1, 2, 3, 6, 7, 8: no connection

##### **Terminal Block**

See Figure 4 on page 9.

#### **C.3 POTS/ISDN INTERFACE:**

##### **RJ-45**

- Pin 4: 2-wire RING
- Pin 5: 2-wire TIP
- Pins 1, 2, 3, 6, 7, 8: no connection

Copyright © 2001  
Patton Electronics Company  
All Rights Reserved.





## Free Manuals Download Website

<http://myh66.com>

<http://usermanuals.us>

<http://www.somanuals.com>

<http://www.4manuals.cc>

<http://www.manual-lib.com>

<http://www.404manual.com>

<http://www.luxmanual.com>

<http://aubethermostatmanual.com>

Golf course search by state

<http://golfingnear.com>

Email search by domain

<http://emailbydomain.com>

Auto manuals search

<http://auto.somanuals.com>

TV manuals search

<http://tv.somanuals.com>