

OWNER'S MANUAL

- ASSEMBLY
- OPERATION
- MAINTENANCE
- PARTS LIST

**Model No.
248-650A**

Important :

**Read Safety Rules and
Instructions Carefully**

POWER SHREDDER

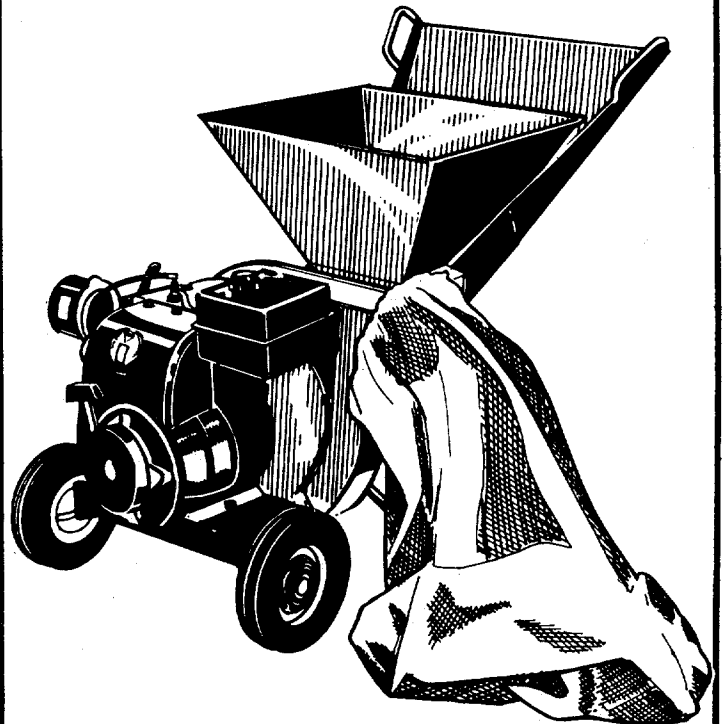

LIMITED WARRANTY

For one year from the date of original retail purchase, MTD PRODUCTS INC will either repair or replace, at its option, free of charge, F.O.B. factory or authorized service firm, any part or parts found to be defective in material or workmanship. Transportation charges under this warranty must be paid by the purchaser unless return is requested by MTD PRODUCTS INC.

This warranty will not apply to any part which has become inoperative due to misuse, excessive use, accident, neglect, improper maintenance, alterations, or unless the unit has been operated and maintained in accordance with the instructions furnished. This warranty does not apply to the engine, motor, battery, battery charger or component parts thereof. Please refer to the applicable manufacturer's warranty on these items.

This warranty will not apply where the unit has been used commercially.

Warranty service is available through your local authorized service dealer or distributor. If you do not know the dealer or distributor in your area, please write to the Customer Service Department of MTD.

The return of a complete unit will not be accepted by the factory unless prior written permission has been extended by MTD.

This warranty gives you specific legal rights. You may also have other rights which vary from state to state.

WARNING TO PURCHASERS OF INTERNAL COMBUSTION ENGINE EQUIPPED MACHINERY OR DEVICES IN THE STATE OF CALIFORNIA

The equipment which you have just purchased does not have a spark arrester. If this equipment is used on any forest covered land, brush covered land, or grass covered unimproved land in the State of California, before using on such land, the California law requires that a spark arrester be provided. In addition, spark arrester is required by law to be in effective working order. The spark arrester must be attached to the exhaust system and comply with Section 4442 of the California Public Resources Code.

IMPORTANT

It is suggested that this manual be read in its entirety before attempting to assemble or operate. Keep this manual in a safe place for future reference and for ordering replacement parts.

This unit is shipped WITHOUT GASOLINE or OIL. After assembly, see operating section of this manual for proper fuel and amount.

SAFE OPERATION PRACTICES FOR POWER SHREDDERS

TRAINING

1. The operator should become fully familiar with all of the different sections of the Owner's Manual before attempting to operate this equipment.
2. Children must never be allowed to operate this equipment.
3. This equipment should never be operated in the vicinity of children, pets or other persons.
4. Never run your machine in an enclosed area as the exhaust from the engine contains carbon monoxide, which is an odorless, tasteless and a deadly poison gas.
5. Never allow your hands or any part of your body or clothing inside the feeding chamber, discharge chute, or near any moving part while the machine or engine is running.
6. If it is necessary for any reason to inspect or repair the feeding chamber or any part of the machine where a moving part can come in contact with your body or clothing, stop the machine, allow it to cool, and disconnect the spark plug wire from the spark plug before attempting such inspection or repair.
3. The engine must be kept clean of debris and other accumulations.
4. Do not allow an accumulation of processed material to build up in the discharge area as this will prevent proper discharge and can result in kick-back from feed opening.
5. Never allow your hands or any other part of your body or clothing inside the feeding chamber, discharge chute or near any moving part while the engine is running.
6. Keep all guards and deflectors in place and in good working condition to assure continued safe operation.
7. Always stand clear of the discharge area when operating this machine.
8. Keep your face and body back from the feed opening to avoid accidental bounce back of any material.
9. Do not over-reach. Keep proper balance and footing at all times.
10. The engine governor settings on your machine must not be altered, changed, or tampered with. The governor controls the maximum safe operating speeds and protects the engine and all moving parts from damage caused by overspeed.

PREPARATION

1. It is recommended that the operator of this equipment obtain and wear safety glasses at all times while operating the machine.
2. Wear proper apparel, avoid wearing loose fitting clothing.
3. This machine should be operated only upon an earthen level surface.
4. Assure that all screws, nuts and bolts and other fasteners are properly secured.

OPERATION

1. When feeding shreddable material into this equipment, be extremely careful that pieces of metal, rocks, bottles, cans or other foreign objects are not included.
2. If the cutting mechanism strikes any foreign object or if your machine should start making an unusual noise or vibration, immediately stop the engine and disconnect the spark plug wire from the spark plug. Allow the machine to stop and take the following steps:
 - A. Inspect for damage.
 - B. Replace or repair any damaged parts.
 - C. Check for any loose parts and tighten to assure continued safe operation.

MAINTENANCE AND STORAGE

1. When this equipment is stopped for servicing, inspection, storage or to change an accessory, make sure the spark plug wire is disconnected from the spark plug. The machine should be allowed to cool down before making such inspection, adjustments, service, etc. Maintain your machine with care and keep it clean for the best and continued safe operation.
2. When not in use, your machine should be stored out of the reach of children. Keep where gasoline fumes will not reach an open flame or spark. For long periods of storage, the gasoline should be drained and disposed in a safe manner. Always allow the machine to cool before storing in any enclosure.

PRE-ASSEMBLY



The right and left side of your shredder is determined from operator's position.

Before any step is undertaken, the instructions for that step should be read through.

TOOLS REQUIRED:

1. (1) 7/16" Open End or Box Wrench
2. (1) 1/2" Open End or Box Wrench
3. (1) Adjustable Wrench.

MATERIALS REQUIRED:

1. Funnel (for gas and oil—NOTE: Do not mix).
2. S.A.E. 30 Oil—2¾ pints.
3. Gas (regular).
4. Cleaning rag.

PARTS IN CARTON

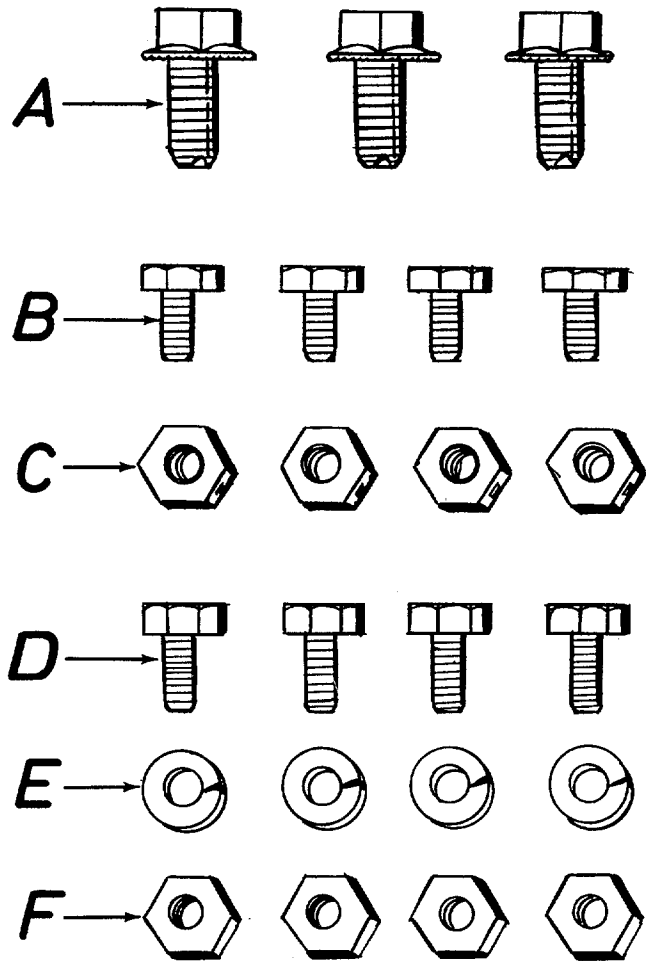

FIGURE 2.

ASSEMBLY INSTRUCTIONS

1. Remove the shredder, parts pack and all literature from the carton before discarding carton.
2. **Chute Deflector:**
 - A. Place the chute deflector, in position on the left hand side of shredder.
 - B. Secure with four hex screws (D), lockwashers (E) and hex center locknuts (F). See figure 3.



Heads of screws are assembled from the inside, nuts and washers go on the outside. Start all four screws, nuts and washers by hand, then tighten with an adjustable wrench and 7/16" wrench.

FIGURE 1.



The letters listed below will be referred to throughout the following text for easier hardware identification.

LIST OF CONTENTS IN HARDWARE PACK:

- A (3) Hex washer head self threading screws
- B (4) Hex screws 1/4-20 x 1/2" long
- C (4) Hex center locknuts 1/4-20 thread
- D (4) Hex screws 1/4-20 x 1/2" long
- E (4) Lockwashers 1/4" screw
- F (4) Hex center locknuts 1/4-20 thread

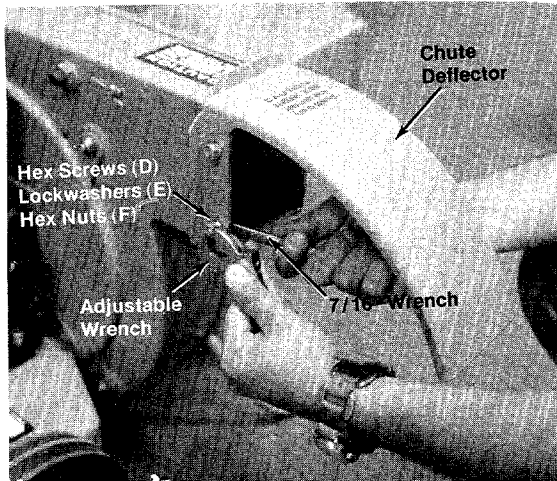

FIGURE 3.

3. Hopper:

- A. Place the hopper on the shredder, start all three self threading screws (A) by hand and then tighten with a $\frac{1}{2}$ " wrench. See figure 4.

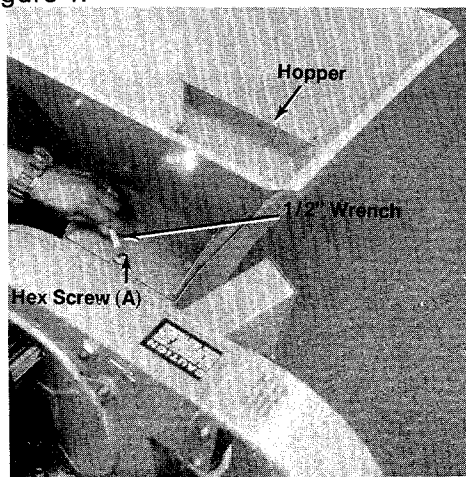

FIGURE 4.

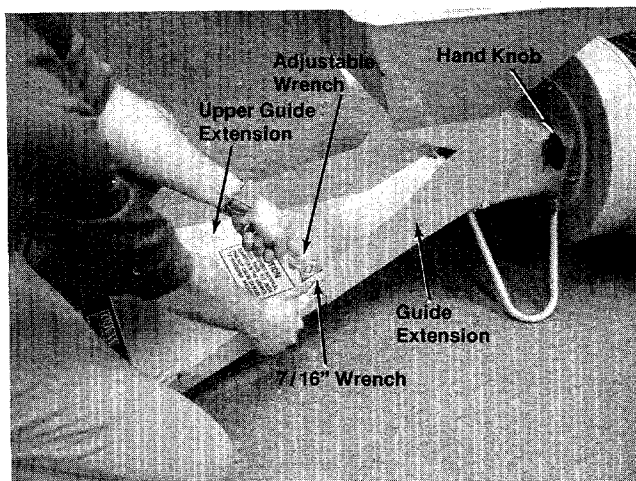

FIGURE 5.

4. Upper Guide Extension :

- A. Loosen hand knob on right hand side of shredder. See figure 5.
 - B. Place upper guide extension in place on guide extension and secure with four hex screws (B) and hex center locknuts (C). A $\frac{7}{16}$ " wrench and adjustable wrench is required. See figure 5.
5. Place the bag over the chute deflector and pull draw string and lock. See figure 6.

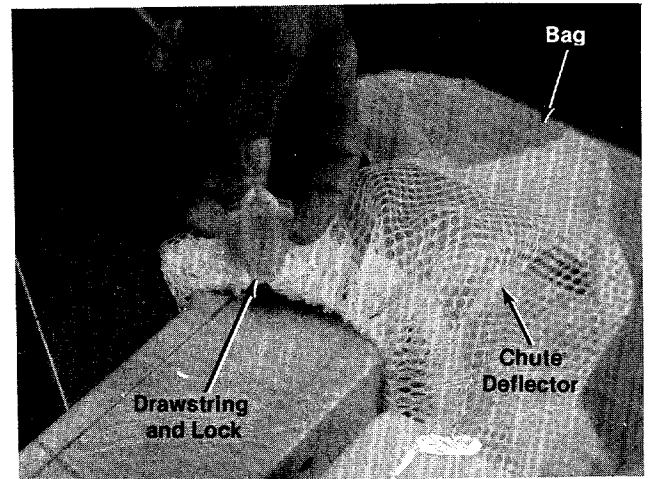

FIGURE 6.

OPERATION

1. Service engine with gas and oil. See engine manual packed with shredder for complete instructions for the care and maintenance of engine. READ DIRECTIONS CAREFULLY.
2. When ready to start engine, place throttle control lever in CHOKE position and start engine in accordance with instructions in engine manual. After engine starts, move throttle control lever to RUN position. The engine is stopped by placing control lever in the STOP position.



CAUTION
The manufacturer recommends that the operator wear safety glasses or some other suitable eye protection as it is possible for chips to be ejected out of the inlet openings while feeding material.

USING YOUR SHREDDER

Your shredder is designed for safe, efficient, operation. CARE, OF COURSE, MUST BE EXERCISED THAT HANDS ARE KEPT AWAY FROM ALL OPENINGS.

Your shredder upper guide extension is adjustable. It may be adjusted to desired height by loosening the hand knob as shown in figure 7. Upper guide extension can be raised to close opening if hopper is not installed.

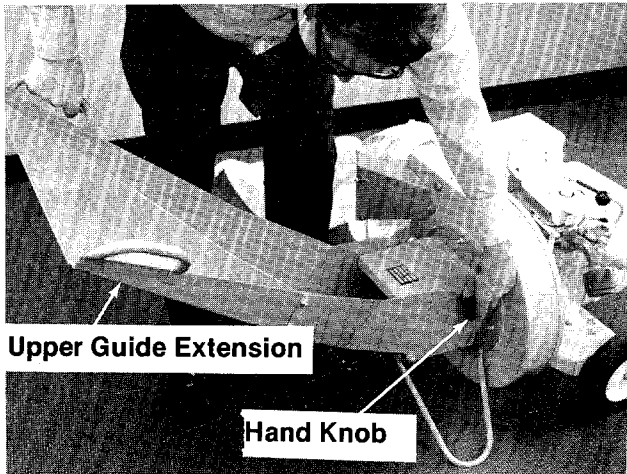

FIGURE 7. UPPER GUIDE EXTENSION ADJUSTMENT

Feed the material so that it slides down upper guide extension. See figure 8.

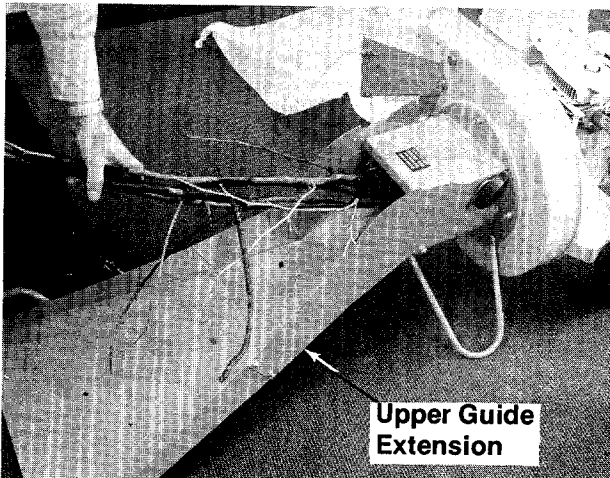

FIGURE 8. FEEDING MATERIAL INTO UPPER GUIDE EXTENSION

Leaves and small twigs can be raked into the upper guide extension, when the upper guide extension is lower. See figure 9.



FIGURE 9. RAKING LEAVES AND TWIGS INTO UPPER GUIDE EXTENSION

CHIP-IT GUIDE

A steady flow of material provides the best results. Bulky material, such as stalks or heavy branches, should be fed into the chip-it guide extension. See figure 10.

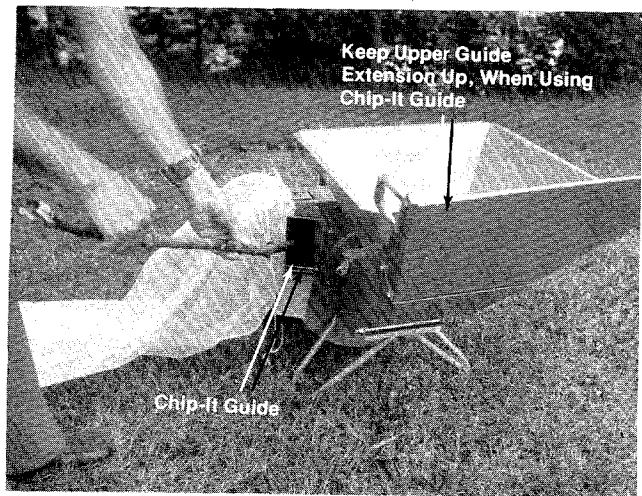

FIGURE 10. FEEDING MATERIAL INTO CHIP-IT GUIDE

It is possible to feed too fast and you will find it will take some experimenting with feeding rates to get the most out of your shredder without stalling the engine. Rotate the material.

Under certain conditions, it may be necessary to push the materials into the inlet guide assembly. When this becomes necessary, use a small diameter stick—NOT YOUR HANDS. The stick should be of a size that will be ground up if it gets into the impeller assembly.

The discharge chute will direct the shredded material into a pile or a container.

Do not force or jam material into chip-it guide.

HOPPER

Leaves and smaller branches can be fed into the hopper. See figures 11 and 12.



FIGURE 11. FEEDING MATERIAL INTO HOPPER

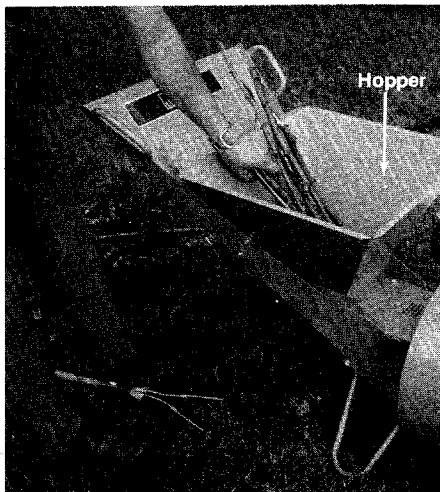

FIGURE 12. FEEDING MATERIAL INTO HOPPER



CAUTION

Do Not deposit material larger than 1/2" diameter in hopper. This may cause damage to the shredding mechanism. Any material heavier than 1/2" should be fed into the chip-it guide extension. (See figure 10.)



NOTE

Your shredder is equipped with a nylon bag with drawstring lock. This will accommodate a perforated disposable plastic bag.



CAUTION

Keep clear of the chute area since the shredded material comes out with considerable velocity. Always stop engine and disconnect spark plug wire when changing bags.

MAINTENANCE



CAUTION

Always stop engine and disconnect spark plug wire before doing any maintenance.

Cutting Blade—The blade may easily be removed for grinding or replacement as follows:

1. Remove guide extension assembly by removing four elastic locknuts (Ref. No. 11). See page 14.
2. Remove bolt (Ref. No. 38), lockwasher (Ref. No. 37), flat washer (Ref. No. 36) holding blade (Ref. No. 45) and blade retainer (Ref. No. 48) to engine crankshaft. See page 14.



NOTE

Blade is reversible and can be assembled to crankshaft with either side showing.

When sharpening blade, follow the original angle of grind as a guide. It is extremely important that each cutting edge receives an equal amount of grinding to prevent an unbalanced blade. An unbalanced blade will cause excessive vibration when rotating at high speeds and may cause damage to the unit. Upon reassembly, make certain all parts are assembled properly and tightened securely.

Flails and Fingers—The flails and fingers can be reversed when they become dull.

LUBRICATION

WHEELS—Wheel bearings are of lifetime Fortiflex. They require no lubrication.

ENGINE—Follow engine manual for lubrication instructions.

BEFORE STARTING



NOTE

Do not mix oil with gasoline.

1. Fill fuel tank with fresh regular gasoline. (See figure 13.)

2. Fill crankcase with oil. (See figure 13.)

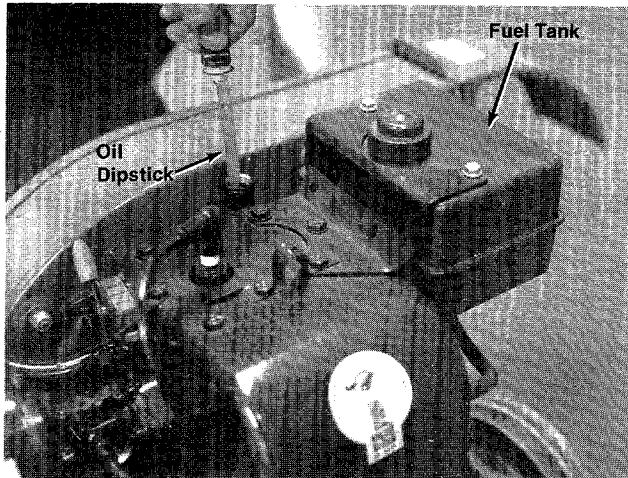

FIGURE 13.

Position equipment so that engine is setting level. Remove dip stick or oil filler plug (Figure 13). Pour oil into oil filler tube from which dip stick was removed and fill to FULL mark on dip stick. Do not overfill. After initial filling follow instructions on dip stick. Be sure dip stick is screwed into filler opening as far as it will go when measuring oil level.

During initial break-in period, oil level should be watched closely. See ENGINE MAINTENANCE.

Use MS classification oil. Do not use oils marked only MM or ML or unmarked.

Above 32° use SAE 30; below 32° use SAE 10W. These recommendations must be followed for best performance and long life.

Change oil first two (2) hours of operation and check oil level every five (5) operating hours or each time equipment is used.

Change oil every twenty-five (25) operating hours or sooner if equipment is operated in extremely dusty or dirty conditions.



Carburetors are preset at the factory. DO NOT attempt to make adjustments at this time. See carburetor instructions outlined under CARBURETOR ADJUSTMENT.

TO START ENGINE

1. Place control lever (on engine) in START position. See figure 14.
2. Move carburetor control to CHOKE position. See figure 14.

3. Rewind starter—use quick full arm stroke. Keep firm grip on handle and return rope slowly.

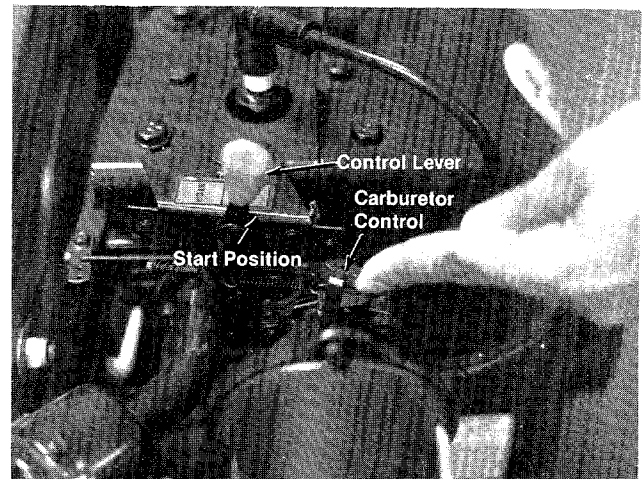

FIGURE 14.

TO STOP ENGINE

1. Move control lever to STOP position. See figure 15.
2. Remove high tension wire from spark plug to prevent accidental starting by children while equipment is unattended.

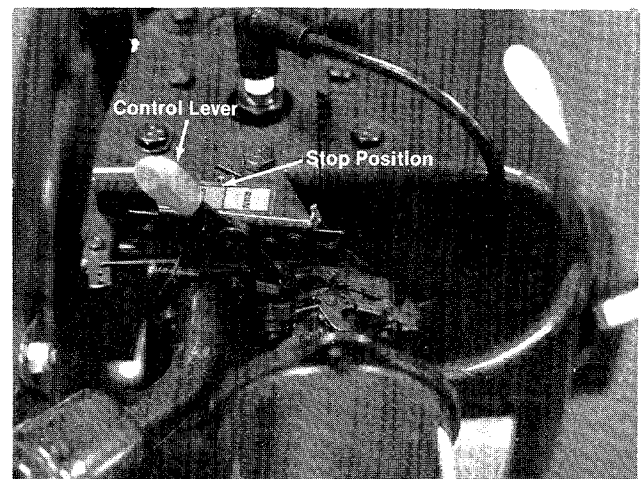

FIGURE 15.

ENGINE MAINTENANCE

To obtain long life and trouble-free service from your engine, certain normal maintenance must be performed as outlined below:

1. Change oil in crankcase after first two (2) hours of operation. Then, follow instructions outlined on page 8.

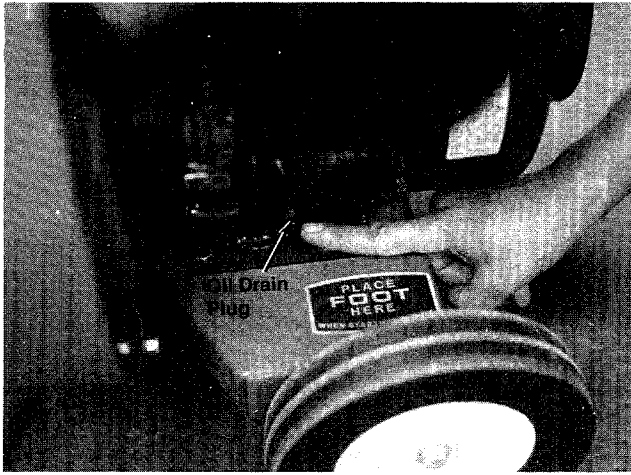

FIGURE 16.



CAUTION

Disconnect high tension wire at spark plug to prevent accidental starting of engine. Unscrew oil drain plug located on side at bottom of engine (figure 16).



NOTE

Always tip engine towards oil drain hole. Be sure oil drains completely.

Replace oil drain plug and refill with oil as directed on page 5 or engine nameplate.

2. Check oil every five (5) operating hours or each time equipment is used.

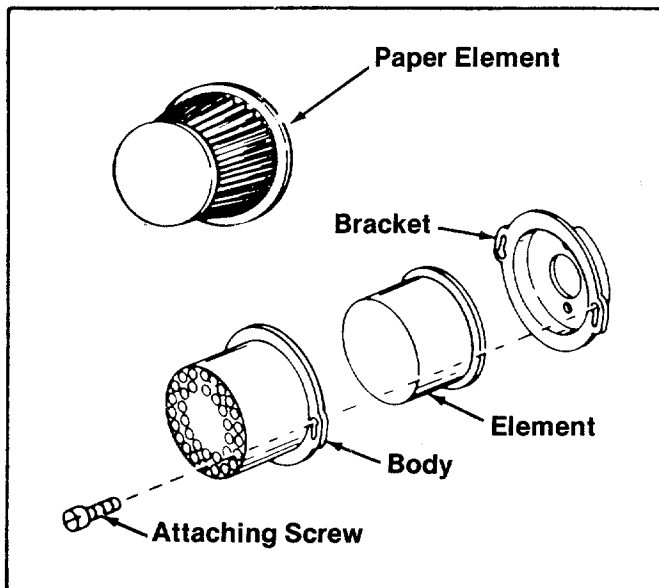

FIGURE 17.

If engine has dip stick, keep oil level at mark indicated by adding if necessary.

3. Cleaning engine—This is an aircooled engine which operates most efficiently when the cooling fins are clean.

Clean cylinder fins and underside of tank or housing thoroughly of all accumulated grass and debris.

4. Air Cleaner. (See figure 17.)

- a. Paper Type Element. Remove every 10 hours or oftener if under dusty conditions. Tap to remove loose dirt and/or blow from inside out with low pressure air. Replace if torn or perforated or when plugged to maintain proper carburetor setting (50 hours). **DO NOT WASH IN ANY LIQUID AND DO NOT OIL.**

CARBURETOR ADJUSTMENTS

Do not make unnecessary adjustment. Factory settings are correct for most application. If adjustments are needed, proceed as follows:

1. Close power adjusting needle (figure 18) by turning to right (clockwise). Close finger tight only. Forcing will cause damage.
2. Open one turn (counterclockwise).
3. Close idle adjusting needle (figure 18) by turning to right (clockwise). Close finger tight only. Forcing will cause damage.
4. Open one and one-half (1½) turns (counterclockwise).
5. Start engine. Follow starting instructions page 5.
6. With throttle open (carburetor control at RUN or FAST position) adjust power adjusting needle one-eighth (1/8) turn at a time forward or backward until engine runs smoothly. If engine tends to stall under load enrich mixture slightly (counterclockwise).
7. Hold throttle lever closed or move carburetor control to IDLE or SLOW position and adjust idle adjusting needle until engine runs smoothly proceeding as in step six (6) above.
8. Allow several seconds between each adjustment when performing either step six (6) or seven (7) to allow engine to react to new setting.

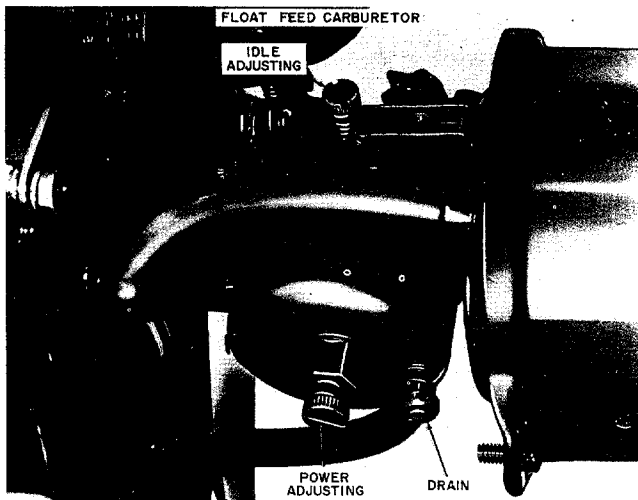

FIGURE 18.

STORAGE INSTRUCTIONS

In event engine is to be stored for any length of time (30 days or more), prepare as follows:

1. Drain gasoline by tipping or by syphon hose, then run engine until remainder is used and tank and carburetor are empty.



CAUTION

Drain into container outdoors away from fire or flame.

2. Drain carburetor by pressing upward on bowl drain (figure 18).
3. Inside protection of engine for storage is performed by removing spark plug and pouring one ounce of SAE 30 oil through spark plug hole into cylinder. Crank engine, without starting, several times to spread oil over cylinder walls.

248-650A

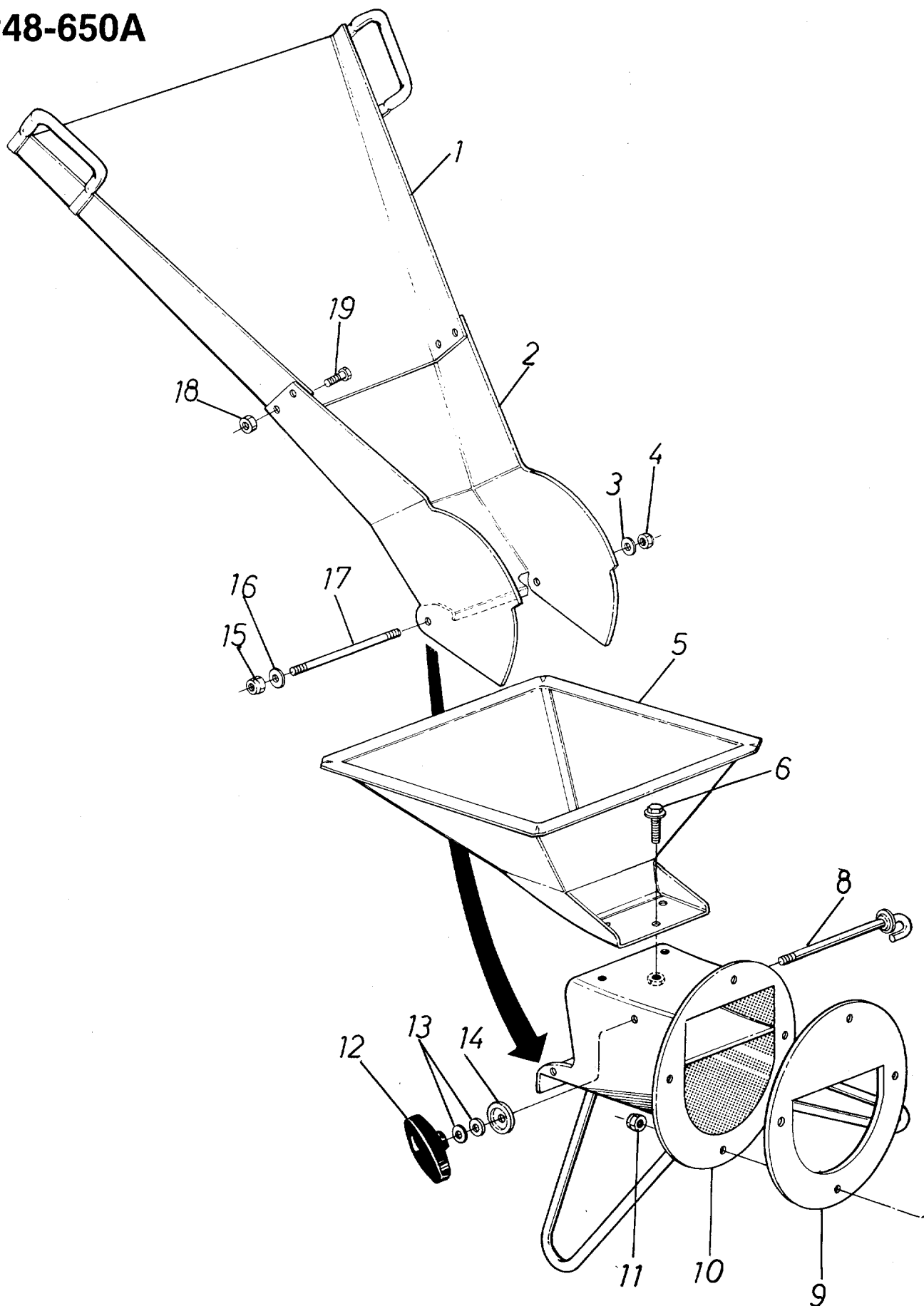

PARTS LIST FOR MODEL 248-650A

| REF. NO. | PART NO. | COLOR CODE | DESCRIPTION | NEW PART |
|----------|----------|------------|--|----------|
| 1 | 11460 | —463 | Guide Extension Assembly | |
| 2 | 11472 | —463 | Guide Extension | |
| 3 | 736-0264 | | Flat Washer 5/16" Scr. * | |
| 4 | 712-0429 | | Elastic Stopnut 5/16-18 Thd. | |
| 5 | 11481 | —463 | Hopper Assembly | |
| 6 | 710-0601 | | Hex Wash. Hd. Self Thd. Scr. 5/16-18 x .50" Lg. | |
| 8 | 11479 | —463 | Clamp Rod Assembly | |
| 9 | 11454 | —463 | Back-up Plate | |
| 10 | 11467 | —463 | Inlet Guide Assembly | |
| 11 | 712-0429 | | Elastic Stopnut 5/16-18 Thd. | |
| 12 | 09966 | | Knob Ass'y. | |
| 13 | 736-0264 | | FI-Wash. .50" Dia. * | |
| 14 | 11480 | | Stop Washer | |
| 15 | 712-0429 | | Elastic Stopnut 5/16-18 Thd. | |
| 16 | 736-0264 | | FI-Wash. .50" Dia. * | |
| 17 | 711-0566 | | Chute Pivot Rod | |
| 18 | 712-0107 | | Hex Cent. L-Nut 1/4-20 Thd. | |
| 19 | 710-0289 | | Hex Scr. 1/4-20 x .50" Lg. * | |

*For faster service obtain standard nuts, bolts and washers locally. If these items cannot be obtained locally, order by part number and size as shown on parts list.

(463—Top Flite Red)

When ordering parts, if color or finish is important use the appropriate color code shown above (e.g. Top Flite Red Finish—11907 (463).)

The engine is not under warranty by the shredder manufacturer. If repairs or service is needed on the engine, please contact your nearest authorized engine service outlet. Check the "Yellow Pages" of your telephone book under "Engines—Gasoline."

**Find It Fast
In The
Yellow Pages**



NOTE

This instruction manual covers various models and all specifications shown do not necessarily apply to your model. Specifications subject to change without notice or obligation.

248-650A

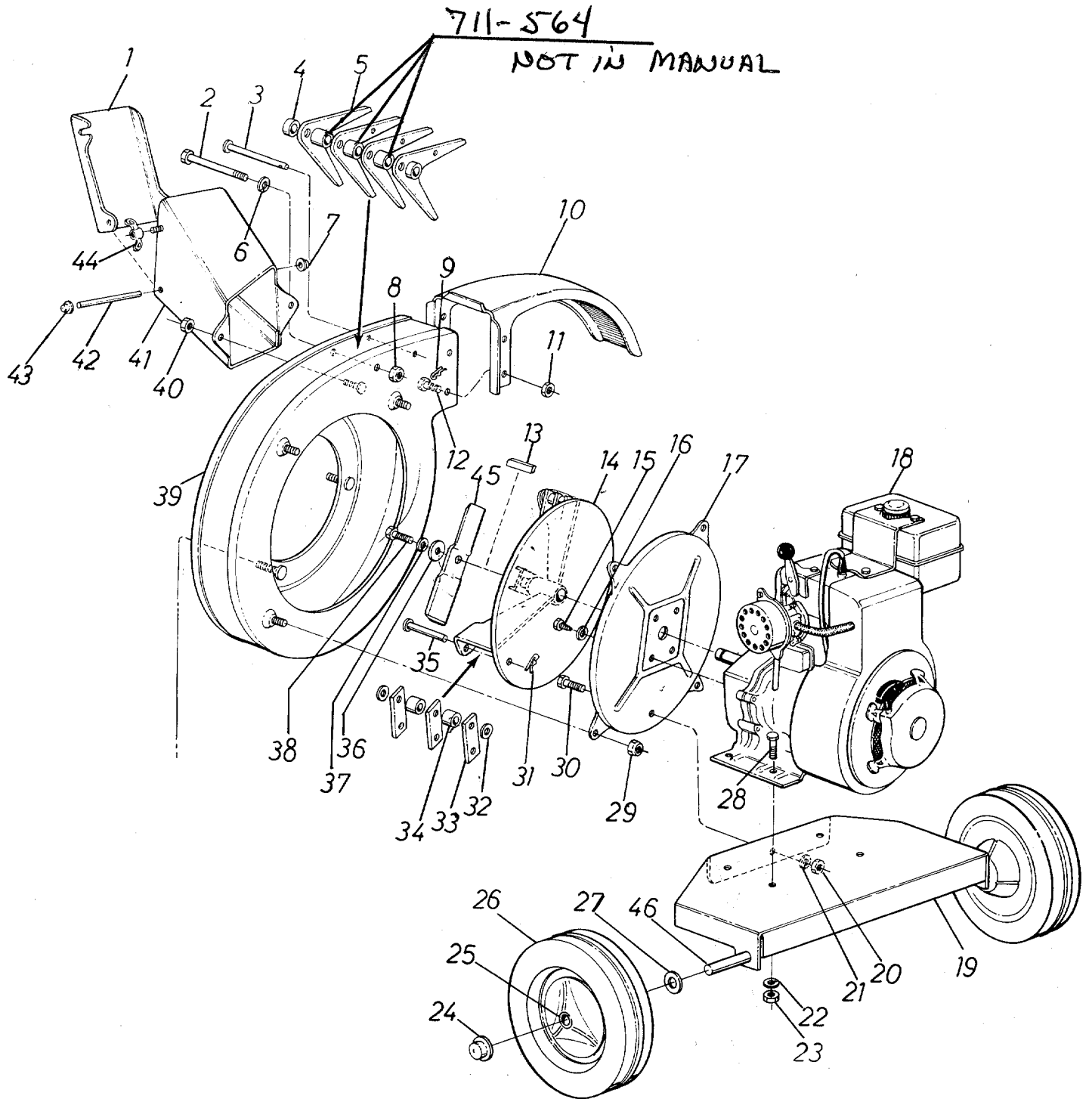

PARTS LIST FOR MODEL NO. 248-650A

| REF. NO. | PART NO. | COLOR CODE | DESCRIPTION | NEW PART |
|----------|----------|------------|--|----------|
| 1 | 11476 | —463 | Door—Chip-It | |
| 2 | 710-0465 | | Hex Scr. 1/2-20 x 4.50" Lg. * | |
| 3 | 711-0580 | | Clevis Pin | |
| 4 | 711-0579 | | Flail Spacer 7/32" Lg. | |
| 5 | 11455 | —463 | Cutting Finger | |
| 6 | 736-0921 | | L-Wash. 1/2" Scr. * | |
| 7 | 726-0111 | | Palnut 3/16" Dia. | |
| 8 | 712-0922 | | Hex Jam Nut 1/2-20 Thd. * | |
| 9 | 714-0507 | | Cotter Pin 3/32" Dia. x 3/4" Lg. * | |
| 10 | 11465 | —463 | Chute Deflector | |
| 11 | 712-0107 | | L-Nut 1/4-20 Thd. | |
| 12 | 710-0289 | | Hex Scr. 1/4-20 x .50" Lg. * | |
| 13 | 714-0114 | | Sq. Key 1/4" x 2.00" Lg. * | |
| 14 | 13430 | —463 | Impeller Assembly | |
| 15 | 710-0157 | | Hex Scr. 5/16-24 x 3/4" Lg. * | |
| 16 | 736-0119 | | L-Wash. 5/16" Scr. * | |
| 17 | 11452 | —463 | Hopper to Engine Mtg. Plate | |
| 18 | — | | Engine | |
| 19 | 11464 | —463 | Engine Mounting Plate | |
| 20 | 712-0123 | | Hex Nut 5/16-24 Thd. * | |
| 21 | 736-0119 | | L-Wash. 5/16" Scr. * | |
| 22 | 736-0119 | | L-Wash. 5/16" Scr. * | |
| 23 | 712-0123 | | Hex Nut 5/16-24 Thd. * | |
| 24 | 726-0221 | | Push Cap | |
| 25 | 07006 | | Fortiflex Bearing | |
| 26 | 08306 | —522 | Wheel Ass'y.—Comp. | |
| 27 | 736-0100 | | FI-Wash. .50" I.D. * | |
| 28 | 710-0624 | | Hex Scr. 5/16-24 x 1.50" Lg. * | |
| 29 | 712-0429 | | Elastic Stopnut 5/16-18 Thd. | |
| 30 | 710-0237 | | Hex Scr. 5/16-24 x .62" Lg. * | |
| 31 | 714-0144 | | Cotter Pin 1/8" Dia. x 1.00" Lg. * (Special) | |
| 32 | 736-0192 | | FI-Wash. .531" I.D. x .937 O.D. x .09 | |
| 33 | 11459 | —463 | Flail | |
| 34 | 711-0564 | | Flail Spacer 23/32" Lg. | |
| 35 | 711-0578 | | Clevis Pin .50" Dia. x 3.0" Lg. | |
| 36 | 736-0247 | | FI-Wash. .406" I.D. x 1.25" O.D. Hdn. | |
| 37 | 736-0217 | | L-Wash. 3/8" Scr. H.D. | |
| 38 | 710-0151 | | Hex Scr. 3/8-24 x 2.00" Lg. H.T. | |
| 39 | 11474 | —463 | Flail Housing Ass'y.—Comp. | |
| 40 | 712-0107 | | Hex Cent. L-Nut 1/4-20 Thd. | |
| 41 | 11477 | —463 | Upper Guide Extension Ass'y. | |
| 42 | 11478 | | Hinge Pin | |
| 43 | 726-0111 | | Palnut 3/16" Dia. | |
| 44 | 712-0109 | | Wing Nut Elastic 1/4-20 Thd. | |
| 45 | 13431 | —463 | Blade | |
| 46 | 11475 | —463 | Axle | |
| | 764-0126 | | Bag (Not Shown) | |

(463—Top Flite Red)

When ordering parts, if color or finish is important use the appropriate color code shown above (e.g. Top Flite Red Finish—11907 (463).)

*For faster service obtain standard nuts, bolts and washers locally. If these items cannot be obtained locally, order by part number and size as shown on parts list.

The engine is not under warranty by the shredder manufacturer. If repairs or service is needed on the engine, please contact your nearest authorized engine service outlet. Check the "Yellow Pages" of your telephone book under "Engines—Gasoline."



PARTS INFORMATION

POWER EQUIPMENT PARTS AND SERVICE

Parts and service for all MTD manufactured power equipment are available through the authorized service firms listed below. All orders should specify the model number of your unit, parts number, description of parts and the quantity of each part required.

| | | |
|--------------------------------|---------------------------|-------|
| ALABAMA | BIRMINGHAM | |
| Auto Electric & Carburetor Co. | 2625 4th Ave. S. | 35233 |
| ARKANSAS | NORTH LITTLE ROCK | |
| Sutton's Lawn Mower Shop | Rt. 4, Box 368 | 72117 |
| | FORT SMITH | |
| Mity Mite Motors, Inc. | 2515 Towson Ave. | 72901 |
| CALIFORNIA | PORTERVILLE | |
| Billious | 75 North D Street | 93257 |
| | SAN BERNARDINO | |
| Lawn Mower Supply Co. | 25608 E. Baseline | 92410 |
| | SAN FRANCISCO | |
| J.W. Jewett Co. | 981 Folsom St. | 94107 |
| | SACRAMENTO | |
| Luttig & Severson | 2030 28th St. | 95818 |
| COLORADO | DENVER | |
| South Denver Lawn Equip. | 527 West Evans | 80223 |
| CONNECTICUT | SUFFIELD | |
| The Jones & Ramsey Co. | 850 Thompsonville Rd. | 06078 |
| FLORIDA | JACKSONVILLE | |
| Radco Distributors | 2403 Market St. | 32206 |
| | CORAL GABLES | |
| Moz-All of Florida, Inc. | 365 Greco Ave. | 33146 |
| GEORGIA | EAST POINT | |
| East Point Cycle & Key | 2834 Church St. | 30344 |
| ILLINOIS | LYONS | |
| Keen Edge Co. | 8615 Ogden Ave. | 60534 |
| INDIANA | ELKHART | |
| Parts & Sales Inc. | 2101 Industrial Pkwy. | 46514 |
| IOWA | DUBUQUE | |
| Power Lawn & Garden Equip. | 2551 J.F. Kennedy | 52001 |
| LOUISIANA | NEW ORLEANS | |
| Suhren Engine Co. | 8330 Earhart Blvd. | 70118 |
| MARYLAND | TAKOMA PARK | |
| Center Supply Co. | 6867 New Hampshire Ave. | 20012 |
| MASSACHUSETTS | SPRINGFIELD | |
| Morton B. Collins Co. | 300 Birnie Ave. | 01107 |
| MICHIGAN | MOUNT CLEMENS | |
| Power Equipment Dist. | 36463 South Gratiot | 48043 |
| | LANSING | |
| Lorenz Service Co. | 2500 S. Pennsylvania | 48900 |
| MINNESOTA | MINNETONKA | |
| Hance Distributing Inc. | 11212 Wayzata Blvd. | 55343 |
| MISSISSIPPI | BILOXI | |
| Biloxi Sales & Service, Inc. | 506 Caillavet St. | 39533 |
| MISSOURI | KANSAS CITY | |
| Automotive Equip. Service | 3117 Holmes St. | 64109 |
| | ST. LOUIS | |
| Henzler, Inc. | 2015 Lemay Ferry Rd. | 63125 |
| NEW JERSEY | BELLMAWR | |
| Lawnmower Parts Inc. | 717 Creek Rd., P.O. Box 7 | 08030 |

BRIGGS & STRATTON, TECUMSEH AND PEERLESS PARTS AND SERVICE

Briggs & Stratton, Tecumseh and Peerless parts and service should be handled by your nearest authorized engine service firm. Check the yellow pages of your telephone directory under the listing **Engines—Gasoline**, Briggs & Stratton or Tecumseh Lauson.

| | | |
|--------------------------------|-----------------------|-------|
| NEW YORK | CARTHAGE | |
| Gamble Dist., Inc. | West End Ave. | 13619 |
| NORTH CAROLINA | GREENSBORO | |
| Dixie Sales Company | 327 Battleground Ave. | 27402 |
| | GOLDSBORO | |
| Smith Hardware Co. | 515 N. George St. | 27530 |
| OHIO | WADSWORTH | |
| National Central | 687 Seville Rd. | 44281 |
| | CLEVELAND | |
| Bleckrie, Inc. | 7900 Lorain Ave. | 44102 |
| | CARROLL | |
| Stebe's Mid-State Mower Supply | Box 366 | 43112 |
| | WILLARD | |
| Sunshine Wholesale Tire Outlet | Route 224 | 44890 |
| OKLAHOMA | MUSKOGEE | |
| Victory Motors, Inc. | 605 S. Cherokee | 74401 |
| | ADA | |
| Ada Auto Supply | 301 E. 12th St. | 74820 |
| OREGON | PORTLAND | |
| Kenton Supply Co. | 8216 N. Denver Ave. | 97217 |
| PENNSYLVANIA | LANCASTER | |
| Raub Supply Co. | James & Mulberry Sts. | 17604 |
| | PITTSBURGH | |
| Bluemont Co. | 11125 Frankstown Rd. | 15235 |
| TENNESSEE | KNOXVILLE | |
| Master Repair Service | 2423 Broadway, N.E. | 37917 |
| | MEMPHIS | |
| Memphis Cycle & Supply Co. | 421 Monroe Ave. | 38103 |
| American Sales & Service, Inc. | 1922 Lynnbrook | 38111 |
| TEXAS | DALLAS | |
| Marr Brothers, Inc. | 423 E. Jefferson | 75200 |
| | HOUSTON | |
| Bullard Supply Co. | 2409 Commerce St. | 77003 |
| | SAN ANTONIO | |
| Catto & Putty, Inc. | P.O. Box 2408 | 78206 |
| | FORT WORTH | |
| Woodson Sales Corp. | 1702 N. Sylvania | 76111 |
| UTAH | SALT LAKE CITY | |
| A-1 Engine & Mower Co. | 437 E. 9th St. | 84111 |
| VERMONT | BURLINGTON | |
| Vermont Appliance Co. | 44 Lakeside Ave. | 05401 |
| VIRGINIA | RICHMOND | |
| RBI Corp. | 963 Myers St. | 23260 |
| WASHINGTON | SEATTLE | |
| Bailey's Rebuild, Inc. | 1325 E. Madison St. | 98102 |
| WEST VIRGINIA | CHARLESTON | |
| Young's, Inc. | 233 Virginia St., E. | 25301 |
| WISCONSIN | APPLETON | |
| Automotive Supply Co. | 123 S. Linwood Ave. | 54911 |

WARRANTY PARTS AND SERVICE POLICY

The purpose of warranty is to protect the customer from defects in workmanship and materials, defects which are NOT detected at the time of manufacture. It does not provide for the unlimited and unrestricted replacement of parts. Use and maintenance are the responsibility of the customer. The manufacturer cannot assume responsibility for conditions which it has no control. Simply put, if it's the manufacturer's fault, it's the manufacturer's responsibility; if it's the customer's fault, it's the customer's responsibility.

CLAIMS AGAINST THE MANUFACTURER'S WARRANTY INCLUDES

1. Replacement of Missing Parts on new equipment.
2. Replacement of Defective Parts within the warranty period.
3. Repair of Defects within the warranty period.

All claims MUST be substantiated with the following information:

1. Model Number of unit involved.
2. Date unit was purchased or first put into service.
3. Date of failure.
4. Nature of failure.

MTD PRODUCTS INC • 5389 WEST 130th STREET • P.O. BOX 2741 CLEVELAND OHIO 44111

Free Manuals Download Website

<http://myh66.com>

<http://usermanuals.us>

<http://www.somanuals.com>

<http://www.4manuals.cc>

<http://www.manual-lib.com>

<http://www.404manual.com>

<http://www.luxmanual.com>

<http://aubethermostatmanual.com>

Golf course search by state

<http://golfingnear.com>

Email search by domain

<http://emailbydomain.com>

Auto manuals search

<http://auto.somanuals.com>

TV manuals search

<http://tv.somanuals.com>