

# Operator's Manual

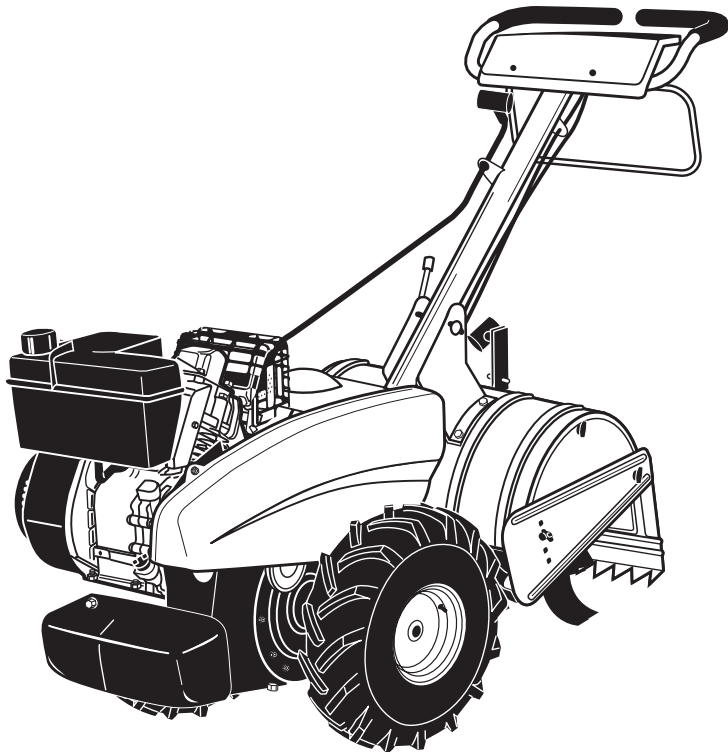

## Rear Tine Tiller Model Series 410

### **IMPORTANT: READ SAFETY RULES AND INSTRUCTIONS CAREFULLY**

**Warning:** This unit is equipped with an internal combustion engine and should not be used on or near any unimproved forest-covered, brush-covered or grass-covered land unless the engine's exhaust system is equipped with a spark arrester meeting applicable local or state laws (if any). If a spark arrester is used, it should be maintained in effective working order by the operator. In the State of California the above is required by law (Section 4442 of the California Public Resources Code). Other states may have similar laws. Federal laws apply on federal lands. A spark arrester for the muffler is available through your nearest engine authorized service dealer or contact the service department, P.O. Box 361131 Cleveland, Ohio 44136-0019.

**MTD LLC, P.O. BOX 361131 CLEVELAND, OHIO 44136-0019**

PRINTED IN U.S.A.

FORM NO. 769-02358

2/3/06

This Operator's Manual is an important part of your new tiller. It will help you assemble, prepare and maintain the unit for best performance. Please read and understand what it says.

## TABLE OF CONTENTS

| Content                            | Page | Content                 | Page |
|------------------------------------|------|-------------------------|------|
| Important Safe Operation Practices | 3    | Maintaining Your Tiller | 13   |
| Assembling Your Tiller             | 5    | Troubleshooting         | 15   |
| Know Your Tiller                   | 8    | Illustrated Parts List  | 16   |
| Operating Your Tiller              | 10   | Warranty                | 24   |
| Making Adjustments                 | 12   |                         |      |

## FINDING AND RECORDING MODEL NUMBER

### BEFORE YOU START ASSEMBLING YOUR NEW EQUIPMENT,

please locate the model plate on the equipment and copy the information from it in the space provided below. A sample model plate is also given below. You can locate the model plate by standing at the operating position and looking down at the center of the rear tine cover. This information will be necessary to use the manufacturer's web site and/or help from the Customer Support Department or an authorized service dealer.

|  |                       |
|--|-----------------------|
| <p>Model Number:</p>   | <p>Serial Number:</p> |
|   |                       |
| <p><b>MTD LLC</b><br/> <b>P. O. BOX 361131</b><br/> <b>CLEVELAND, OH 44136</b><br/> <b>330-220-4683</b><br/> <b>800-800-7310</b></p> |                       |

## CUSTOMER SUPPORT

**Please do *NOT* return the unit to the retailer from where it was purchased, without first contacting Customer Support.**

If you have difficulty assembling this product or have any questions regarding the controls, operation or maintenance of this unit, you can seek help from the experts. Choose from the options below:

1. Visit **mtdproducts.com**. Click on the Service & Support menu option.
2. Phone a **Customer Support Representative** at 1 (800) 800-7310.
3. The engine manufacturer is responsible for all engine-related issues with regards to performance, power rating, specifications, warranty and service. Please refer to the engine manufacturer's Owner's/Operator's Manual, packed separately with your unit, for more information.



---

## SECTION 1: IMPORTANT SAFE OPERATION PRACTICES



**WARNING:** This symbol points out important safety instructions which, if not followed, could endanger the personal safety and/or property of yourself and others. Read and follow all instructions in this manual before attempting to operate this machine. Failure to comply with these instructions may result in personal injury. When you see this symbol - **heed its warning**.



**WARNING:** Engine Exhaust, some of its constituents, and certain vehicle components contain or emit chemicals known to State of California to cause cancer and birth defects or other reproductive harm.

**DANGER:** This machine was built to be operated according to the rules for safe operation in this manual. As with any type of power equipment, carelessness or error on the part of the operator can result in serious injury. This machine is capable of amputating hands and feet and throwing objects. Failure to observe the following safety instructions could result in serious injury or death.

### Training

1. Read, understand, and follow all instructions on the machine and in the manual(s) before attempting to assemble and operate. Keep this manual in a safe place for future and regular reference and for ordering replacement parts.
2. Be familiar with all controls and their proper operation. Know how to stop the machine and disengage them quickly.
3. Never allow children under 14 years old to operate this machine. Children 14 years old and over should read and understand the operation instructions and safety rules in this manual and should be trained and supervised by a parent.
4. Never allow adults to operate this machine without proper instruction.
5. Keep bystanders, helpers, pets and children at least 75 feet from the machine while it is in operation. Stop machine if anyone enters the area.

### Preparation

1. Thoroughly inspect the area where the equipment is to be used. Remove all stones, sticks, wire, and other foreign objects which could be tripped over and cause personal injury.
2. Wear sturdy, rough-soled work shoes and close fitting slacks and shirt. Loose fitting clothes or jewelry can be caught in movable parts. Never operate this machine in bare feet or sandals.
3. Disengage clutch levers and shift (if provided) into neutral ("N") before starting the engine.
4. Never leave this machine unattended with the engine running.
5. Never attempt to make any adjustments while engine is running, except where specifically recommended in the operator's manual.
6. To avoid personal injury or property damage use extreme care in handling gasoline. Gasoline is extremely flammable and the vapors are explosive. Serious personal injury can occur when gasoline is

7. spilled on yourself or your clothes which can ignite. Wash your skin and change clothes immediately.
7. Use only an approved gasoline container.
8. Extinguish all cigarettes, cigars, pipes and other sources of ignition.
9. Never fuel machine indoors.
10. Never remove gas cap or add fuel while the engine is hot or running.
11. Allow engine to cool at least two minutes before refueling.
12. Never over fill fuel tank. Fill tank to no more than ½ inch below bottom of filler neck to provide space for fuel expansion.
13. Replace gasoline cap and tighten securely.
14. If gasoline is spilled, wipe it off the engine and equipment. Move machine to another area. Wait 5 minutes before starting the engine.
15. Never store the machine or fuel container inside near an open flame, spark or pilot light (e.g. furnace, water or space heater, clothes dryer etc.).
16. Allow machine to cool 5 minutes before storing.

### Operation

1. Do not put hands or feet near rotating parts. Contact with the rotating parts can amputate hands and feet.
2. Do not operate machine while under the influence of alcohol or drugs.
3. Never operate this machine without good visibility or light. Always be sure of your footing and keep a firm hold on the handles.
4. Keep bystanders, helpers, pets, and children at least 75 feet from the machine while it is in operation. Stop the machine if anyone enters the area.
5. Be careful when tilling in hard ground. The tines may catch in the ground and propel the tiller forward. If this occurs, let go of the handle bars and do not restrain the machine.
6. Exercise extreme caution when operating on or crossing gravel surfaces. Stay alert for hidden hazards or traffic. Do not carry passengers.

7. Never operate the machine at high transport speeds on hard or slippery surfaces.
8. Exercise caution to avoid slipping or falling.
9. Look down and behind and use care when in reverse or pulling machine towards you.
10. Start the engine according to the instructions found in this manual and keep feet well away from the tines at all times.
11. After striking a foreign object, stop the engine, disconnect the spark plug wire and ground against the engine. Thoroughly inspect the machine for any damage. Repair the damage before starting and operating.
12. Disengage all clutch levers and stop engine before you leave the operating position (behind the handles). Wait until the tines come to a complete stop before unclogging the tines, making any adjustments, or inspections.
13. Never run an engine indoors or in a poorly ventilated area. Engine exhaust contains carbon monoxide, an odorless and deadly gas.
14. Muffler and engine become hot and can cause a burn. Do not touch.
15. Use caution when tilling near fences, buildings and underground utilities. Rotating tines can cause property damage or personal injury.
16. Do not overload machine capacity by attempting to till soil to deep at to fast of a rate.
17. If the machine should start making an unusual noise or vibration, stop the engine, disconnect the spark plug wire and ground it against the engine. Inspect thoroughly for damage. Repair any damage before starting and operating.
18. Keep all shields, guards and safety devices in place and operating properly.
19. Never pick up or carry machine while the engine is running.
20. Use only attachments and accessories approved by the manufacturer. Failure to do so, can result in personal injury.
21. If situations occur which are not covered in this manual, use care and good judgment. Contact your dealer or telephone 1-800-800-7310 for assistance and the name of your nearest servicing dealer.

## Maintenance & Storage

1. Never tamper with safety devices. Check their proper operation regularly.
2. Check bolts and screws for proper tightness at frequent intervals to keep the machine in safe working condition. Also, visually inspect machine for any damage.
3. Before cleaning, repairing, or inspecting, stop the engine and make certain the tines and all moving parts have stopped. Disconnect the spark plug wire and ground it against the engine to prevent unintended starting.

4. Do not change the engine governor settings or over-speed the engine. The governor controls the maximum safe operating speed of the engine.
5. Maintain or replace safety and instruction labels, as necessary.
6. Follow this manual for safe loading, unloading, transporting, and storage of this machine.
7. Never store the machine or fuel container inside where there is an open flame, spark or pilot light such as a water heater, furnace, clothes dryer etc.
8. Always refer to the operator's manual for proper instructions on off-season storage.
9. If the fuel tank has to be drained, do this outdoors.
10. Observe proper disposal laws and regulations for gas, oil, etc. to protect the environment.

## Your Responsibility

1. Restrict the use of this power machine to persons who read, understand and follow the warnings and instructions in this manual and on the machine.
2. The safety label on the tiller is reproduced below for your review. To ensure safe operation of the tiller, follow the instructions on all labels closely.

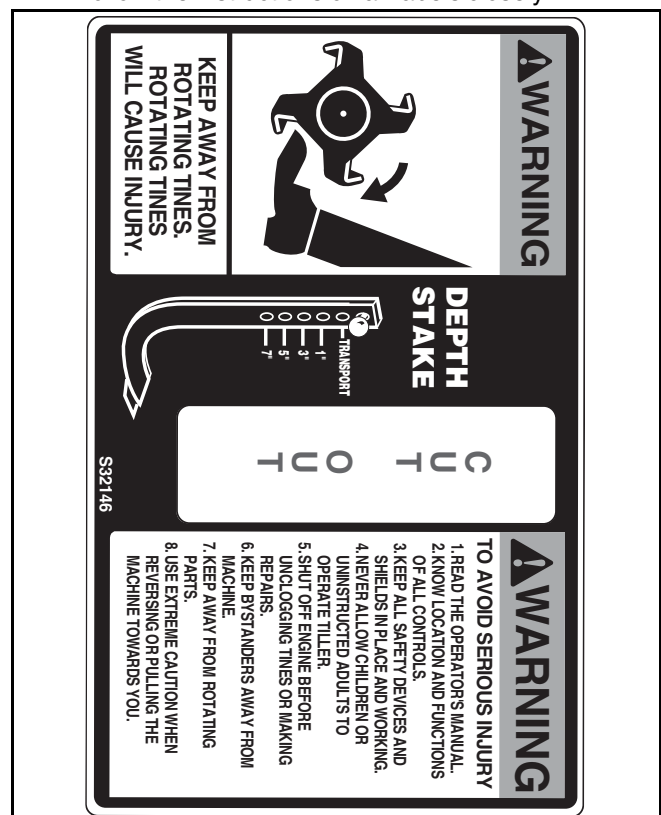

## SECTION 2: ASSEMBLING YOUR TILLER

**NOTE:** This operator's manual covers various models of tillers. The units illustrated may vary slightly from your unit. Follow only those instructions which pertain to your model number.

**NOTE:** References to right or left side of the tiller are determined from behind the unit in the operating position.

### To Remove Unit From Carton

- Remove staples, break glue on top flaps, or cut tape at carton end and peel along top flap to open carton.
- Remove loose parts included with unit (i.e., operator's manual, etc.).
- Cut corners and lay carton down flat.
- Remove packing material.
- Roll or slide unit out of carton. Check carton thoroughly for loose parts.
- Extend control cable and lay on the floor. Be careful not to bend or kink control cable.

**IMPORTANT:** This unit is shipped without gasoline or oil in the engine. Be certain to service engine with gasoline and oil as instructed in the separate engine manual before operating your machine.

### Loose Parts In Carton

Depth Stake

Handle Assembly

Shift Rod

**NOTE:** All hardware needed for assembly is attached to the loose parts or the tiller.

### Before Assembly



**WARNING:** Disconnect the spark plug wire and ground it against the engine to prevent unintended starting.

### Attaching Depth Stake

- Tip the tiller forward so it rests on front counterweight.
- Unthread the "T" knob from the top of the depth stake and remove the flat washer and hex bolt. Remove the hairpin clip from the clevis pin. See Figure 1.
- Raise the tine shield hinge flap assembly and insert the depth stake assembly in the slot (under the tine shield) and up through the tine shield assembly.
- Insert clevis pin through the tine shield and depth stake assemblies. Secure with hairpin clip.

- Insert hex bolt into the top hole of the depth stake assembly. Place flat washer on the hex bolt and thread "T" knob onto the hex bolt. Tighten securely. See Figure 1.
- Tip the tiller back down so it rests on the tines.

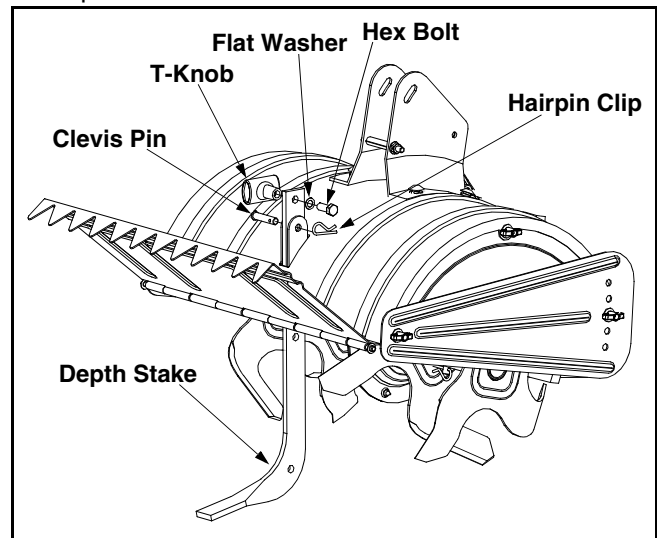

Figure 1

### Attaching Handle Assembly

- Remove the handle adjustment crank, flange nut, retainer bracket, shoulder bolt, and lock nut from the pivot bracket.
- Place the handle assembly in position in the handle pivot bracket lining the upper holes in the handle with the slots in the pivot bracket. See Figure 2.

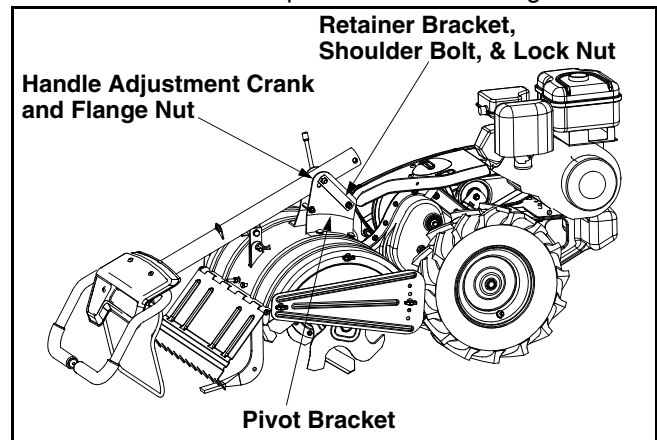

Figure 2

- Lift up the handle assembly and align the bottom holes in the handle assembly with the holes in the pivot bracket. Insert shoulder bolt from the left side of unit through the pivot bracket and the retainer bracket on the right hand side of the unit. See Figure 3.

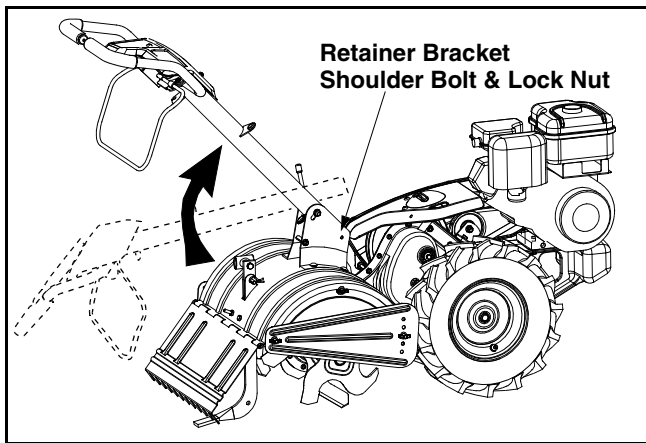

Figure 3

- Place the hex opening of the flange nut retainer bracket over the flange nut securing the handle adjustment crank and install the lock nut on the lower shoulder bolt. See Figure 4.
- Pivot handle assembly into position desired. Tighten the bottom bolt, lock nut, and the handle adjustment lock securely.

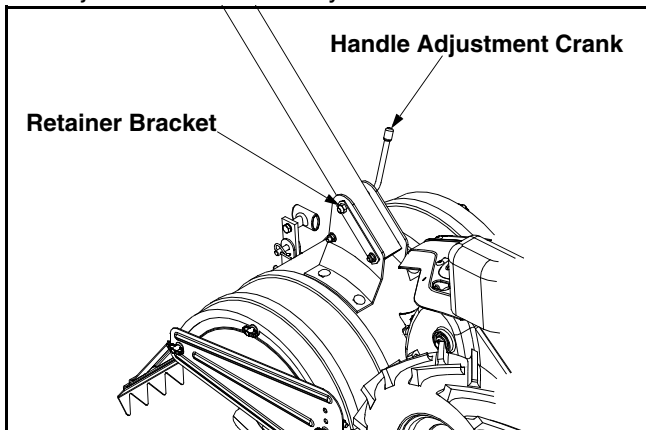

Figure 4

### Attaching Gear Shift Rod

- Remove the T-handle, hairpin clip, flat washer and rubber washer from the end of the gear shift rod. Slide the rod up through the right side of bracket on the front of the handle assembly. See Figure 5.
- Insert the end of the gear shift rod through the opening in the top of the shift cover and into the shift bracket. Secure with rubber washer first, flat washer, and then hairpin clip. See Figure 5.
- Install the nut and T-handle on the gear shift rod.

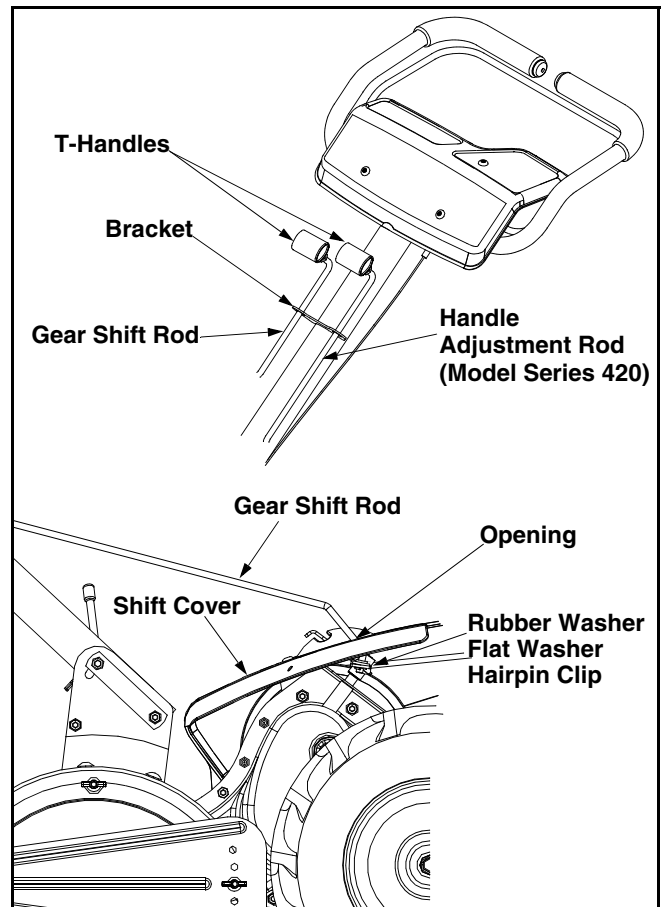

Figure 5

### Attaching Clutch Cable

- Route the clutch cable underneath the handle and through the cable clip. Be careful not to bend or kink the cable. See Figure 6.

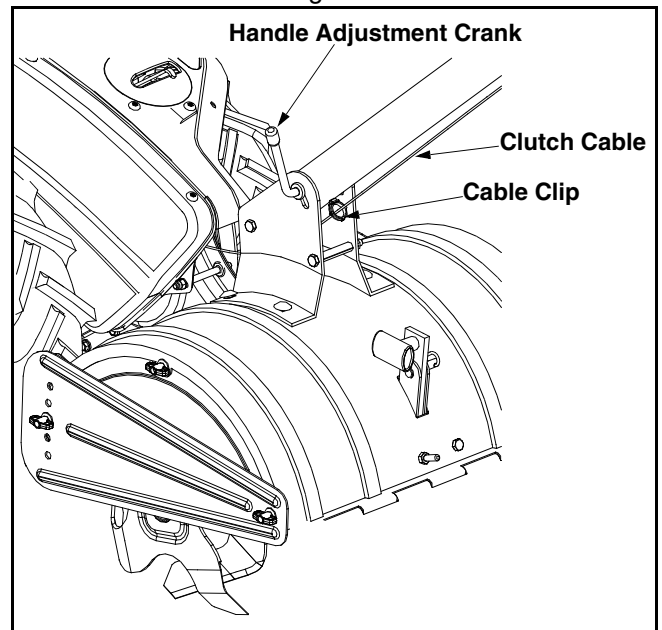

Figure 6

- Remove one hex nut from the threaded casing on the end of the cable. Slip the wire up through the slot on the cable bracket underneath the handle.
- Push the end of the casing up through the cable bracket. Rethread the hex nut on the end of the cable. Do not tighten at this time.

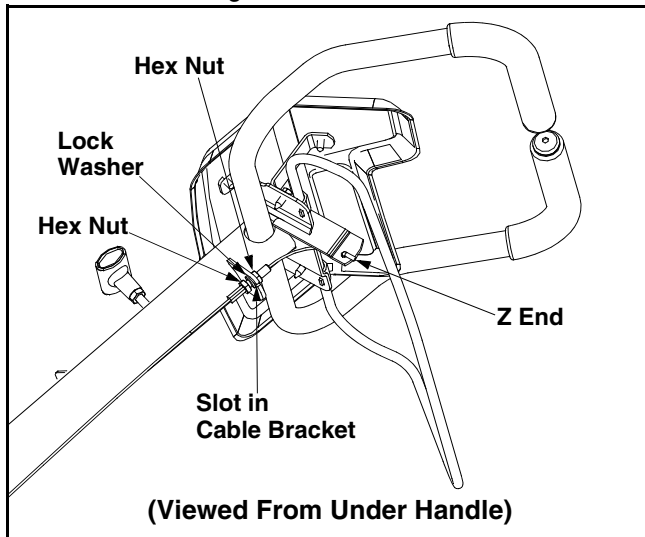

Figure 7

- Pull the cable upwards to obtain slack and hook the Z end of the cable from right to left into the bracket on the clutch control (beneath the handle panel). Tighten the nut against the cable bracket. See Figure 7.

**NOTE:** Do not overtighten clutch cable, since too much tension may cause it to break.

## Final Clutch Adjustment

**IMPORTANT:** Service the engine with oil and gasoline before checking this adjustment. Refer to the separate engine manual packed with your tiller.

- Position the tiller so the front counterweight is against a solid object, such as a wall. With the gear selection lever in NEUTRAL, start the engine. Refer to Operation section.

**NOTE:** Keep hands out of belt area while unit is operating.

- Standing on the right side of the tiller, visually examine the belt (inside the belt cover). It should not be turning.
- **If the belt turns with the unit in neutral**, adjust by moving the hex nut below the cable bracket **down** a few turns. Tighten the upper hex nut against the bracket. See Figure 7.
- Now move the shift lever to FORWARD (Wheels Forward) position. Carefully engage the clutch by squeezing the clutch handle against the handle. The wheels should spin.
- **If the wheels do not spin with the unit in forward**, adjust by moving the hex nut which is above the cable bracket **up** a few turns. Tighten the bottom hex nut against the bracket.

Recheck both adjustments, and readjust as necessary. Make certain hex nuts at cable bracket are tight (do not overtighten clutch cable).

**NOTE:** If additional adjustment is required, it may be necessary to remove the belt cover and move the hex nuts at the other end of the clutch cable to increase belt tension.

## Tire Pressure

The tires on your unit may be over-inflated for shipping purposes. Reduce the tire pressure before operating the unit. Recommended operating tire pressure is approximately 14 p.s.i. on 14 inch tires. Check the sidewall of tire for tire manufacturer's recommended pressure.



**WARNING:** Maximum tire pressure under any circumstances is 30 p.s.i. Equal tire pressure should be maintained on both tires.

## SECTION 3: KNOW YOUR TILLER

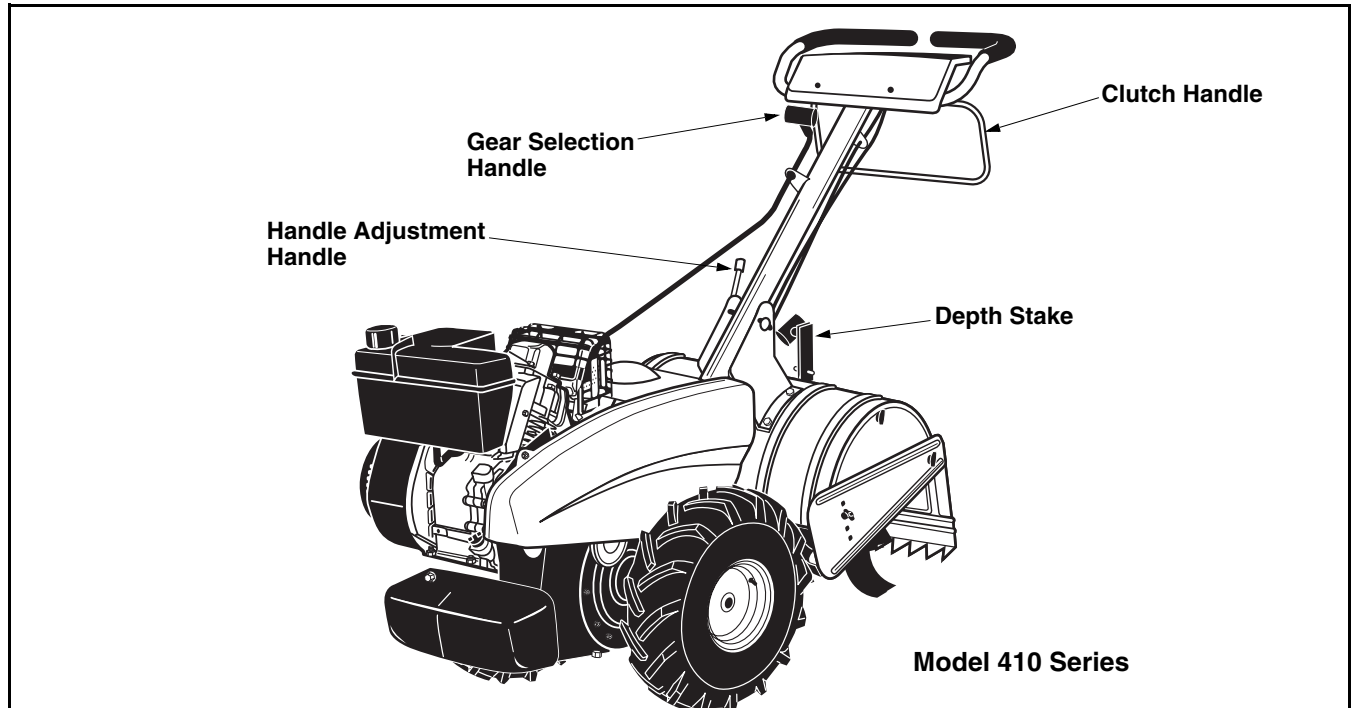

Figure 8



**WARNING:** Read, understand, and follow all instructions and warnings on the machine and in this manual before operating.

### Gear Selection Handle

The gear selection handle is located on the front of the handle assembly. It is used to select NEUTRAL, REVERSE, or one of the FORWARD modes.

This tiller is designed for the gear selection handle to be moved while the engine is running. (It will be difficult to obtain all four positions with the engine off.) Pull or push the handle so that the indicator on top of shift cover points to the area of the operating mode desired. See Figure 8.

**NOTE:** If difficulty is encountered in moving the gear selection handle, refer to the following helpful hints:

- To shift into forward or reverse wheel drive, move tiller forward slightly then backward to allow the gears to synchronize.
- To shift into forward wheels and tine drive, push forward slightly on the gear selection handle and slowly engage the clutch handle allowing the gears to synchronize.
- To stop forward movement and tine drive, release the clutch handle. Do not shift gears with the clutch handle engaged except when engaging the tines.

### Reverse

Reverse wheel drive only.

### Neutral

Transmission is in neutral.

### Wheels Forward

Forward wheel drive only.

### Tines Reverse

Forward wheel drive and reverse tine drive.



**WARNING:** Make certain unit is in NEUTRAL when starting the engine.

### Clutch Handle

The clutch handle is located beneath the handle. Squeezing the clutch handle against the handle engages the wheel and tine drive mechanisms. See Figure 8.

### Throttle Control

The throttle control lever is located on the engine. It controls the engine speed and stops the engine.



## **Choke Lever (If Equipped)**

The choke lever is located on top of the carburetor on the back of the engine underneath the muffler. It is used to enrich the fuel mixture in the carburetor when starting a cold engine.



**Be careful when disengaging the Choke, especially after the engine warms up, the muffler will be hot!**

## **Primer Button (If Equipped)**

The primer button is located behind the air cleaner. It is used to enrich the fuel mixture in the carburetor when starting a cold engine.

## **Depth Stake**

The depth stake controls the tilling depth. Refer to “Setting the Depth” in the Operating Section.

## **Handle Adjustment Crank**

The handle may be adjusted to the height desired. Loosen the handle height adjustment lock a few turns. Pivot handle up or down to desired position. Tighten lock. See Figure 8.

## **Fuel Shut-Off Valve (If Equipped)**

Make sure the valve is in the On (horizontal) position when starting the unit. Any time the tiller is not in operation (i.e., storing, performing maintenance or adjustment), make sure the valve is in the OFF (vertical) position.

## **Engine Controls**

See the separate engine manual for additional information and functions of the engine controls.

---

## SECTION 4: OPERATING YOUR TILLER



**WARNING:** Read, understand, and follow all instructions and warnings on the machine and in this manual before operating.

### Before Starting

### Gas And Oil Fill-Up

Service the engine with gasoline and oil as instructed in the separate engine manual packed with your tiller. Read instructions carefully.



**WARNING:** Use extreme care when handling gasoline. Gasoline is extremely flammable and the vapors are explosive. Never fuel machine indoors or while the engine is hot or running.

### Starting Engine

**NOTE:** When pushing the unit with the engine off, you will hear a ratcheting sound (gear noise) which is normal.



**WARNING:** Be sure no one is standing in front of the tiller while the engine is running or being started.

- Place gear selection lever in NEUTRAL.
- Place the throttle control lever in FAST position or if equipped, place the engine speed control in the START position.
- Move choke lever to CHOKE position or, if equipped, push primer two (2) or three (3) times. Wait about two (2) seconds between each push.

**NOTE:** A warm engine may not require choking or to be primed.

- Stand at side of tiller. Grasp the starter handle and pull out slowly, until it pulls slightly harder. Let rope rewind slowly.
- Pull starter handle rapidly. Do not allow handle to snap back. Allow it to rewind slowly while keeping a firm hold on the starter handle.
- Repeat previous steps until engine starts.
- As engine warms up and begins to operate evenly, move choke lever gradually to RUN position. If engine falters, return to choke position, then slowly move to RUN position.

**NOTE:** See your engine manual packed with your unit for more detailed instructions.

**NOTE:** After starting and prior to using the tiller for the first time, be certain to check the clutch adjustment as described in "Checking the Clutch Adjustment" section of the Assembly Instructions.

### To Stop Engine

- Move throttle control to STOP or OFF position.
- Disconnect spark plug wire and ground to prevent accidentally starting while equipment is unattended.

**NOTE:** After the first ten hours of operation, recheck the clutch adjustment. Refer to final clutch adjustment in Assembly Instructions.

### Setting The Depth

Tilling depth is controlled by the depth stake which can be adjusted to five different settings. Adjust the side shields as you adjust the depth stake.



**WARNING:** Be certain spark plug wire is disconnected and grounded against the engine when performing any adjustments.

- When using the tiller for the first time, use the second adjustment hole from the top (1" of tilling depth). See Figure 9.

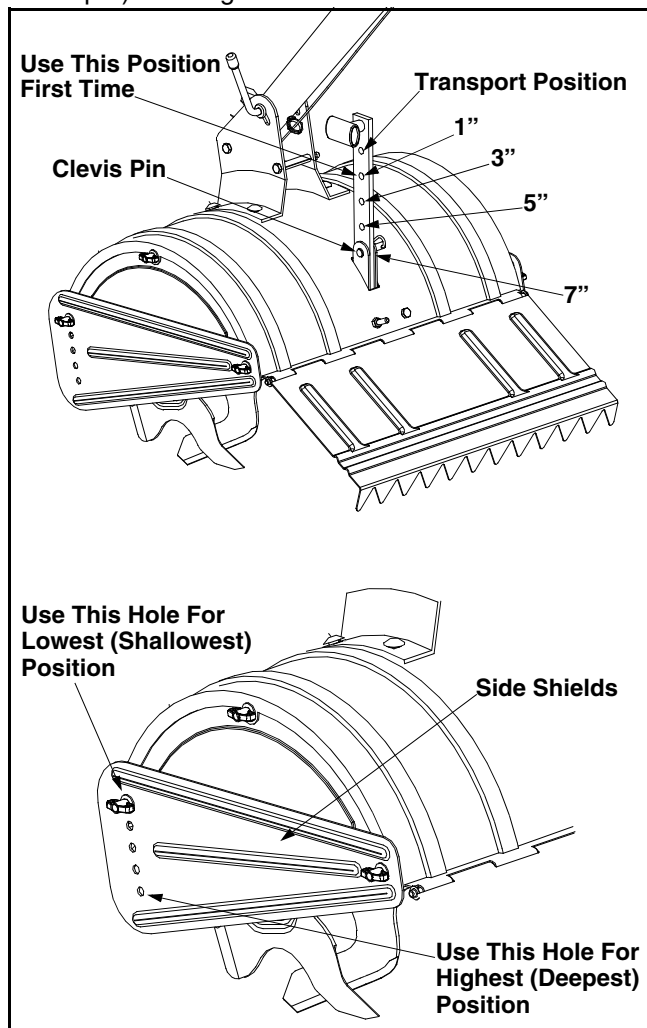

**Figure 9**

- When breaking up sod and for shallow cultivation, use the setting which gives 1" of tilling depth (second hole from the top). Place the side shields in their lowest position.
- For further depth, raise the depth stake and side shields and also make one or two more passes over the area.
- When tilling loose soil, the depth stake may be raised to its highest position (use bottom adjustment hole) to give the deepest tilling depth. Raise the side shields to their highest position.
- To transport tiller, lower the depth stake (use top adjustment hole).

To adjust the depth stake, remove the clevis pin and hairpin clip. Move the depth stake to the desired setting and secure with the clevis pin and hairpin clip. See Figure 9.

To adjust the side shields, remove the wing nuts. Move the side shield to the desired position and replace the wing nuts. Tighten securely.

## Operating the Tiller

- Select the depth stake setting.
- Start engine as instructed on the previous page.
- Move gear selection handle to one of the forward modes or reverse.



**WARNING:** Do not move the gear selection handle with the wheels or tines engaged. Make certain the unit is stopped completely before changing the gear selection. A partial engagement may be necessary when engaging tines.

- Squeeze the clutch handle against the handle to engage the wheels and tines.

**NOTE:** Make certain the gear selection indicator is correctly positioned before engaging the clutch handle. If it is between gears, the engine will stall.

To transport tiller, **do not** engage the tines. Select the wheel drive only.



**WARNING:** Do not push down on the handles so that the wheels are lifted off the ground while using the tine drive, or the tiller could move backward and cause personal injury.

For best results, it is recommended the garden be tilled twice (lengthwise, then widthwise) to pulverize the soil.

---

## SECTION 5: MAKING ADJUSTMENTS



**WARNING:** Never attempt to make any adjustments while the engine is running, except where specified in operator's manual.

### Handle Adjustment

The handle may be adjusted to the height desired and on Model 420 series, the handle may also be adjusted to be in line with the tiller or swung to the left or right. Refer to the handle adjustment in the Know Your Tiller section for details.

### Belt Tension Adjustment

Periodic adjustment of the belt tension may be required due to normal stretch and wear on the belt. Adjustment is needed if the tines or wheels seem to hesitate while turning, but the engine maintains the same speed.

To adjust the tension on the belt, refer to Final Clutch Adjustment in Assembly Instructions.

### Engine Adjustment

Refer to the separate engine manual for engine adjustment instructions.

## SECTION 6: MAINTAINING YOUR TILLER



**WARNING: Disconnect the spark plug wire and ground it against the engine before performing any repairs or maintenance.**

### Engine

Refer to the separate engine manual for engine maintenance instructions.

Maintain **engine oil** as instructed in the separate engine manual packed with your unit. Read and follow instructions carefully.

Service **air cleaner** every ten hours under normal conditions. Clean every hour under extremely dusty conditions. Poor engine performance and flooding usually indicates that the air cleaner should be serviced. To service the air cleaner, refer to the separate engine manual packed with your unit.

**IMPORTANT:** Never run your engine without air cleaner completely assembled.

The **spark plug** should be cleaned and the gap reset every 25 hours of engine operation. Spark plug replacement is recommended at the start of each tiller season; check engine manual for correct plug type and gap specification.

**Clean the engine** regularly with a cloth or brush. Keep the cooling system (blower housing area) clean to permit proper air circulation which is essential to engine performance and life. Be certain to remove all dirt and combustible debris from muffler area.

### Lubrication

#### Transmission

The transmission is pre-lubricated and sealed at the factory. It requires no checking unless the transmission is disassembled. To fill with grease, lay the right half of the transmission on its side, add 22 ounces of Benalene 920 grease, and assemble the left half to it. This grease can be obtained at your nearest authorized dealer by ordering part number 737-0300.

#### Clutch Handle

Lubricate the pivot point on the clutch handle and the cable at least once a season with light oil. The control must operate freely in both directions.

#### Pivot Points

Lubricate all pivot points and linkages at least once a season with light oil.

#### Tine Shafts

Remove tine assemblies and lubricate the tine shafts at least once a season.

#### Wheel Shafts

Remove wheel assemblies and lubricate the axle shafts at least once a season.

### Cleaning Tine Area

Clean the underside of the tine shield after each use. The dirt washes off the tines easier if rinsed off immediately instead of after it dries. Always towel dry the tiller afterwards and apply a light coat of oil or silicone to prevent rusting or water damage.

**IMPORTANT:** Never use a "pressure washer" to clean your tiller. Water can penetrate tight areas of the tiller and its chaincase and cause serious damage to the unit.

### Tires

Recommended operating tire pressure is approximately 14 p.s.i. on 14 inch tires and 20 p.s.i. on 16 inch tires. (Check sidewall of tire for tire manufacturer's recommended pressure). Maximum tire pressure under any circumstances is 30 p.s.i. Equal tire pressure should be maintained on both tires.

When installing a tire to the rim, be certain rim is clean and free of rust. Lubricate both the tire and rim generously.



**WARNING: Excessive pressure (over 30 p.s.i.) when seating beads may cause tire/rim assembly to burst with force sufficient to cause serious injury.**

### Belt Replacement

Your tiller has been engineered with a belt made of special material (Kevlar Tensile) for longer life and better performance. It should not be replaced with an off-the-shelf belt. Order all belts through your authorized service dealer.

- Disconnect and ground the spark plug wire against the engine.
- Remove the belt cover from the left side of the tiller by removing two torx head screws from the top of belt cover.
- Remove two hex cap nuts and flat washers from front side of the belt cover. Remove the hex nut and flat washer at the back of the cover.
- Remove the belt keeper assembly located behind the engine pulley by removing two hex bolts and lock washers. See Figure 10.
- Remove belt and reassemble the new belt. Follow instructions in reverse order.

**NOTE:** Upon reassembly, make certain the belt is routed over the idler pulley and inside of belt keepers by engine pulley. See Figure 10.

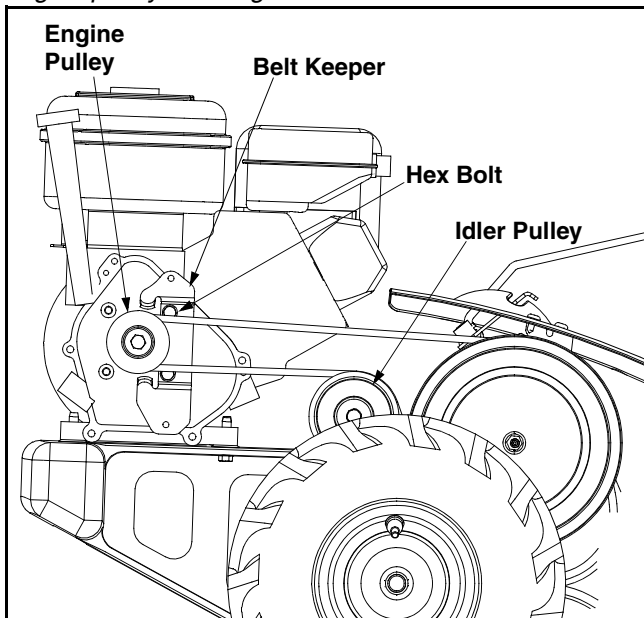

**Figure 10**

## Off-Season Storage

If the tiller will not be used for a period longer than 30 days, the following steps should be taken to prepare the tiller for storage.

- Clean the exterior of engine and the entire tiller thoroughly. Lubricate the tiller as described in the lubrication instructions.
- We do not recommend the use of pressure washers to clean your unit. They may cause damage to electric components, spindles, pulleys, bearings or the engine. The use of pressure washers will result in shortened life and reduce serviceability.
- Refer to the engine manual for correct engine storage instructions.
- Wipe tines with oiled rag to prevent rust.
- Store tiller in a clean, dry area. Do not store next to corrosive materials, such as fertilizer.

**NOTE:** When storing any type of power equipment in an unventilated or metal storage shed, care should be taken to rustproof the equipment. Using a light oil or silicone, coat the equipment and especially any springs, bearings, and cables.

## SECTION 7: TROUBLE SHOOTING GUIDE

| Trouble               | Possible Cause(s)  | Corrective Action   |
|-----------------------|--|---|
| Engine fails to start | Fuel tank empty, or stale fuel.<br>Throttle control lever not in correct starting position (if so equipped).<br>Blocked fuel line.<br>Dirty aircleaner.<br>Choke not in ON position.<br>Spark plug wire disconnected.<br>Faulty spark plug.<br>Engine flooded. | Fill tank with clean, fresh gasoline. Fuel will not last over thirty days unless a fuel stabilizer is used.<br>Move throttle lever to start position.<br>Clean fuel line.<br>Refer to the engine manual packed with your unit.<br>Move choke to ON position.<br>Connect wire to spark plug.<br>Clean, adjust gap or replace.<br>Refer to the engine manual packed with your unit. |
| Engine runs erratic   | Unit running on CHOKE.<br>Spark plug wire loose.<br>Blocked fuel line or stale fuel.<br>Vent in gas cap plugged.<br>Water or dirt in fuel system.<br>Dirty air cleaner.<br>Carburetor out of adjustment.   | Move choke lever to OFF position.<br>Connect and tighten spark plug wire.<br>Clean fuel line; fill tank with clean, fresh gasoline. Fuel will not last over thirty days unless a fuel stabilizer is used.<br>Clear vent.<br>Drain fuel tank. Refill with fresh fuel.<br>Refer to the engine manual packed with your unit.<br>Refer to the engine manual packed with your unit.    |
| Engine overheats      | Engine oil level low.<br>Dirty air cleaner.<br>Air flow restricted.<br>Carburetor not adjusted properly.   | Fill crankcase with proper oil.<br>Refer to the engine manual packed with your unit.<br>Refer to the engine manual packed with your unit.<br>Adjust carburetor as instructed in separate engine manual.   |
| Tines do not engage   | Foreign object lodged in tines.<br>Tine clevis pin(s) missing.<br>Pulley and idler not in correct adjustment.<br>Not shifting properly.<br>Control cable not adjusted properly.<br>Belt worn and/or stretched.   | Dislodge foreign object.<br>Replace tine clevis pin(s).<br>Take unit to authorized service dealer.<br>Refer to controls section of operator's manual for proper shifting procedures.<br>Adjust control cable (see assembly instructions).<br>Replace belt.  |
| Wheels do not engage  | Clevis pin missing.<br>Tiller is not being shifted properly.<br>Control cable not adjusted properly.<br>Belt worn and/or stretched.  | Replace clevis pin.<br>Refer to controls section of operator's manual for proper shifting procedures.<br>Adjust control cable (see assembly instructions).<br>Replace belt.   |

**NOTE:** For repairs beyond the minor adjustments above, contact your local authorized service dealer.

# SECTION 8: PARTS LIST FOR MODEL SERIES 410

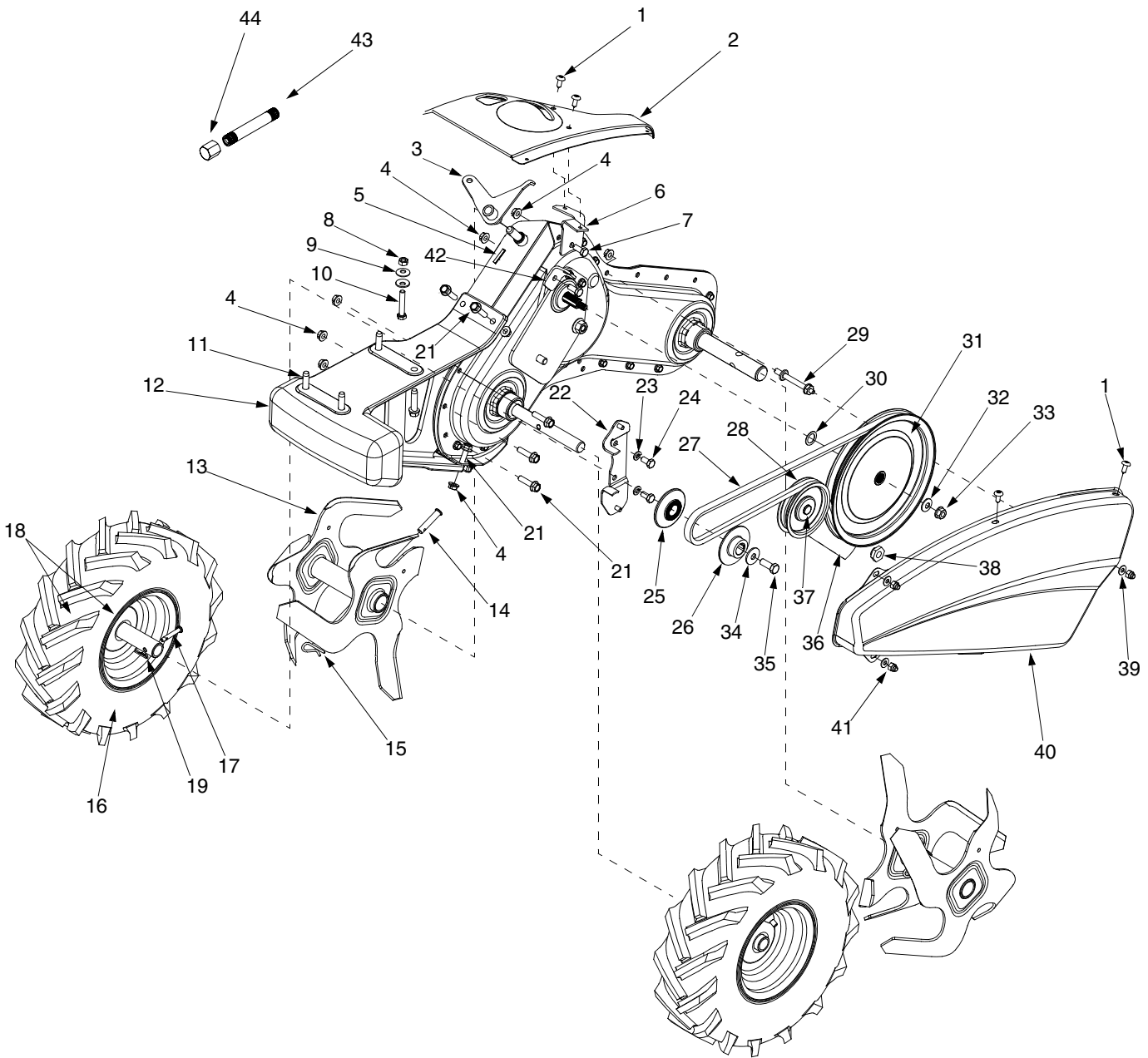



# Model Series 410

| Ref. No. | Part No.  | Part Description                | Ref. No. | Part No.  | Part Description              |
|----------|-----------|---------------------------------|----------|-----------|-------------------------------|
| 1.       | 710-1017  | Hex Screw 1/4-20 x.625          | 22.      | 686-0031A | Belt Keeper Bracket Ass'y     |
| 2.       | 786-0168  | Shift Cover - Tecumseh          | 23.      | 736-0119  | Lock Washer 5/16              |
| 3.       | 686-0095  | Crank Shift Assembly            | 24.      | 710-0237  | Hex Cap Screw 5/16-24 x.625   |
| 4.       | 712-04063 | Hex Lock Nut 5/16-18            | 25.      | 756-0971  | Inner Pulley Half             |
| 5.       | 715-0120  | Spiral Pin                      | 26.      | 756-0972  | Outer Pulley Half             |
| 6.       | 786-0117  | Shift Cover Mounting Bracket    | 27.      | 754-0438  | V-Belt                        |
| 7.       | 710-3008  | Hex Cap Screw 5/16-18 x.75      | 28.      | 756-0405  | Flat Idler                    |
| 8.       | 712-3010  | Hex Nut 5/16-18                 | 29.      | 738-0899  | Bolt 5/16-18 x 1/4-28 x 2.35  |
| 9.       | 736-0242  | Bell Washer.340 ID x.872 OD     | 30.      | 736-0256  | Flat Washer.635 ID x.930 OD   |
| 10.      | 710-3180  | Hex Cap Screw 5/16-18 x 1.75    | 31.      | 756-0634  | Flat Pulley                   |
| 11.      | 710-1007  | Hex Washer Screw 3/8-16 x 1.5   | 32.      | 736-0105  | Spring Washer.401 ID x.870 OD |
| 12.      | 619-0009A | Frame Counterweight             | 33.      | 712-0379  | Flange Lock Nut 3/8-24        |
| 13.      | 642-0015  | Tine Assembly - LH              | 34.      | 736-0452  | Bell Washer.396 ID x 1.140 OD |
|          | 642-0016  | Tine Assembly - RH              | 35.      | 710-1039  | Hex Cap Screw 3/8-24 x 1.0    |
| 14.      | 711-0415  | Clevis Pin                      | 36.      | 786-0080  | Idler Bracket                 |
| 15.      | 714-0149B | Cotter Pin                      | 37.      | 710-0723  | Hex Cap Screw 3/8-16 x 1.25   |
| 16.      | 634-0240  | Complete Wheel Ass'y - RH (14") | 38.      | 738-0876  | Shoulder Nut 7/16-20          |
|          | 634-0241  | Complete Wheel Ass'y - LH (14") | 39.      | 736-3020  | Flat Washer.271 ID x.630 OD   |
| 17.      | 711-1017  | Hex Head Screw 1/4-20           | 40.      | 786-0100  | Belt Cover                    |
| 18.      | 734-1796  | Tire Only (14")                 | 41.      | 712-0392  | Hex Lock Nut 1/4              |
|          | 634-0112  | Rim Only (6.0 x 3.25)           | 42.      | 786-0107  | Cable Bracket                 |
| 19.      | 714-0104  | Cotter Pin                      | 43.      | 737-0298  | Oil Drain Extension           |
| 21.      | 710-1090  | Flange Screw 5/16-18 x 1.25     | 44.      | 737-0132  | End Cap                       |

**IMPORTANT:** For a proper working machine, use Factory Approved Parts.

**V-BELTS** are specially designed to engage and disengage safely. A substitute (non OEM) V-Belt can be dangerous by not disengaging completely.

# Model Series 410

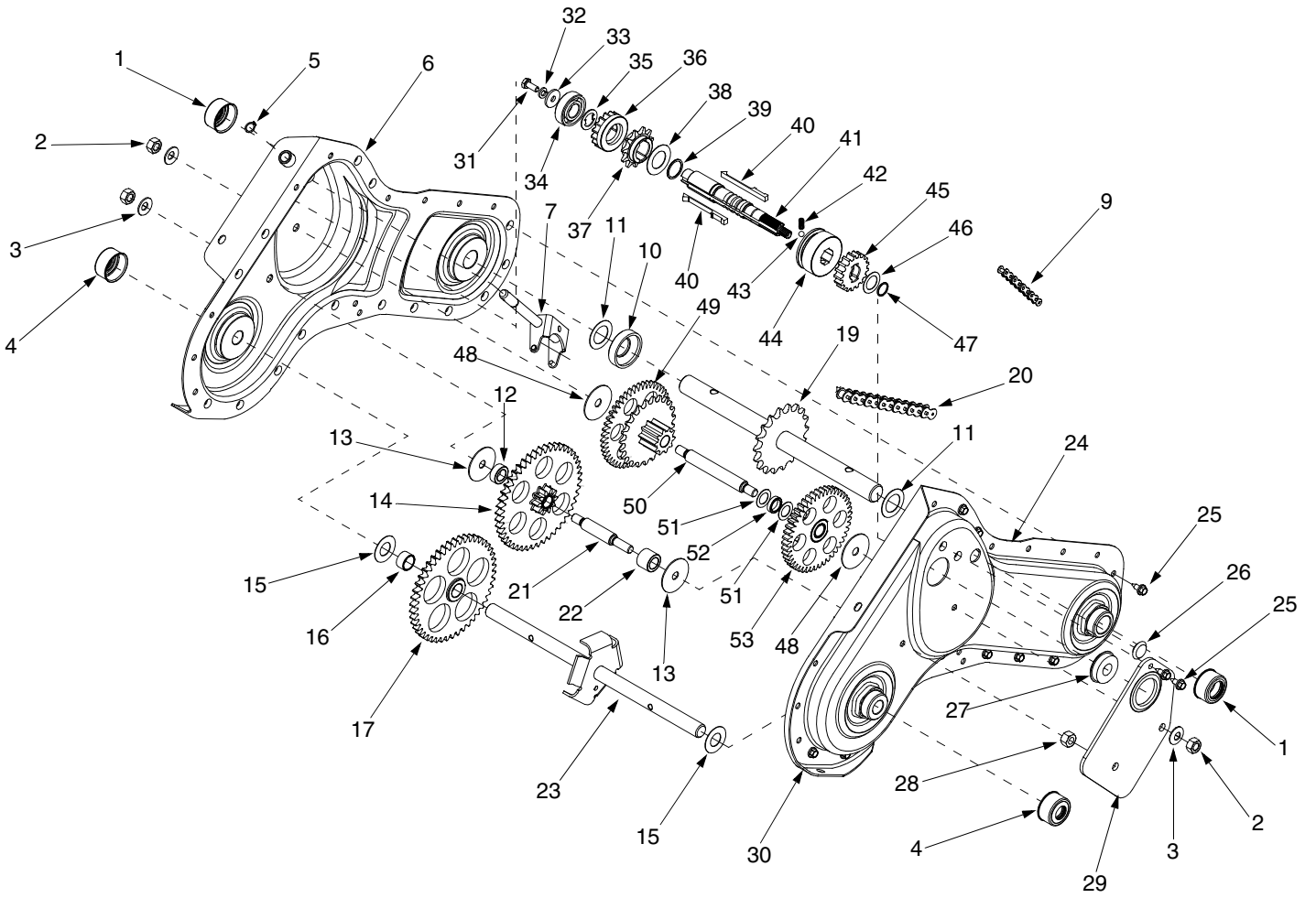

# Model Series 410

| Ref. No. | Part No.  | Part Description                  | Ref. No. | Part No.  | Part Description              |
|----------|-----------|-----------------------------------|----------|-----------|-------------------------------|
| 1.       | 721-0378  | Shaft Seal 1.0 Dia                | 29.      | 786-0086  | Reinforcement Bracket         |
| 2.       | 712-0378  | Hex Nut 7/16-20                   | 30.      | 721-0295  | Chain Case Gasket             |
| 3.       | 736-0407  | Bell Washer.45 ID x 1.0 OD        | 31.      | 710-0751  | Hex Cap Screw 1/4-20 x.625    |
| 4.       | 721-0379  | Shaft Seal.75 Dia                 | 32.      | 736-0329  | Lock Washer 1/4               |
| 5.       | 716-0865  | Snap Ring.50 Dia                  | 33.      | 736-0512  | Flat Washer.281 ID x.875 OD   |
| 6.       | 686-0038  | Gear Case Assembly - RH Half      | 34.      | 741-0124  | Ball Bearing                  |
| 7.       | 618-0245B | Shift Assembly                    | 35.      | 736-0541  | Flat Washer                   |
| 9.       | 713-0233  | Chain - #41 1/2" Pitch x 30 Links | 36.      | 717-1451A | Spur Gear 16T                 |
| 10.      | 750-0570  | Space 1.0 ID x 2.0 OD             | 37.      | 713-0435  | Sprocket 11T #41 Chain        |
| 11.      | 736-0163  | Thrust Washer 1.03 ID x 1.62 OD   | 38.      | 736-0265  | Flat Washer.88 ID x 1.50 OD   |
| 12.      | 750-0936  | Spacer.635 ID x 1.0 OD            | 39.      | 716-0235  | Retainer Ring                 |
| 13.      | 736-0518  | Thrust Washer.445 ID x 1.92 OD    | 40.      | 718-0237  | Clutch Key                    |
| 14.      | 617-0004  | Idler Gear Assembly               | 41.      | 711-1087  | Drive Shaft                   |
| 15.      | 736-0351  | Flat Washer.760 ID x 1.50 OD      | 42.      | 732-0863  | Compression Spring            |
| 16.      | 750-0938  | Spacer.735 ID x.886 OD            | 43.      | 741-0862  | Detent Ball                   |
| 17.      | 717-1458  | Spur Gear 46T                     | 44.      | 718-0234  | Clutch Collar                 |
| 19.      | 611-0021  | Tine Shaft Assembly 18T           | 45.      | 717-1409  | Spur Gear 17T                 |
| 20.      | 713-0226  | Chain - #50 5/8" Pitch x 52 Links | 46.      | 736-0442  | Flat Washer.69 ID x 1.06 OD   |
| 21.      | 738-0885  | Jack Shaft 5/8 Dia. X. 2.06 Lg    | 47.      | 732-0614  | Wire Ring                     |
| 22.      | 750-0935  | Spacer.635 ID x 1.0 OD            | 48.      | 736-0518  | Thrust Washer.445 ID x 1.9 OD |
| 23.      | 611-0058  | Wheel Shaft Assembly              | 49.      | 611-0016  | Intermediate Gear Assembly    |
| 24.      | 686-0039  | Gear Case Assembly - LH Half      | 50.      | 738-0884  | Jack Shaft                    |
| 25.      | 710-0896  | Hex Washer Screw 1/4-14 x.625     | 51.      | 736-0336  | Flat Washer.625 ID x 1.0 OD   |
| 26.      | 726-0331  | Plug                              | 52.      | 750-0931  | Spacer.635 ID x.86 OD         |
| 27.      | 741-0563  | Ball Bearing w/Snap Ring          | 53.      | 617-0003  | Tine Drive Assembly           |
| 28.      | 712-3067  | Hex Patch L-Nut 7/16-20           |          |           |                               |

# Model Series 410

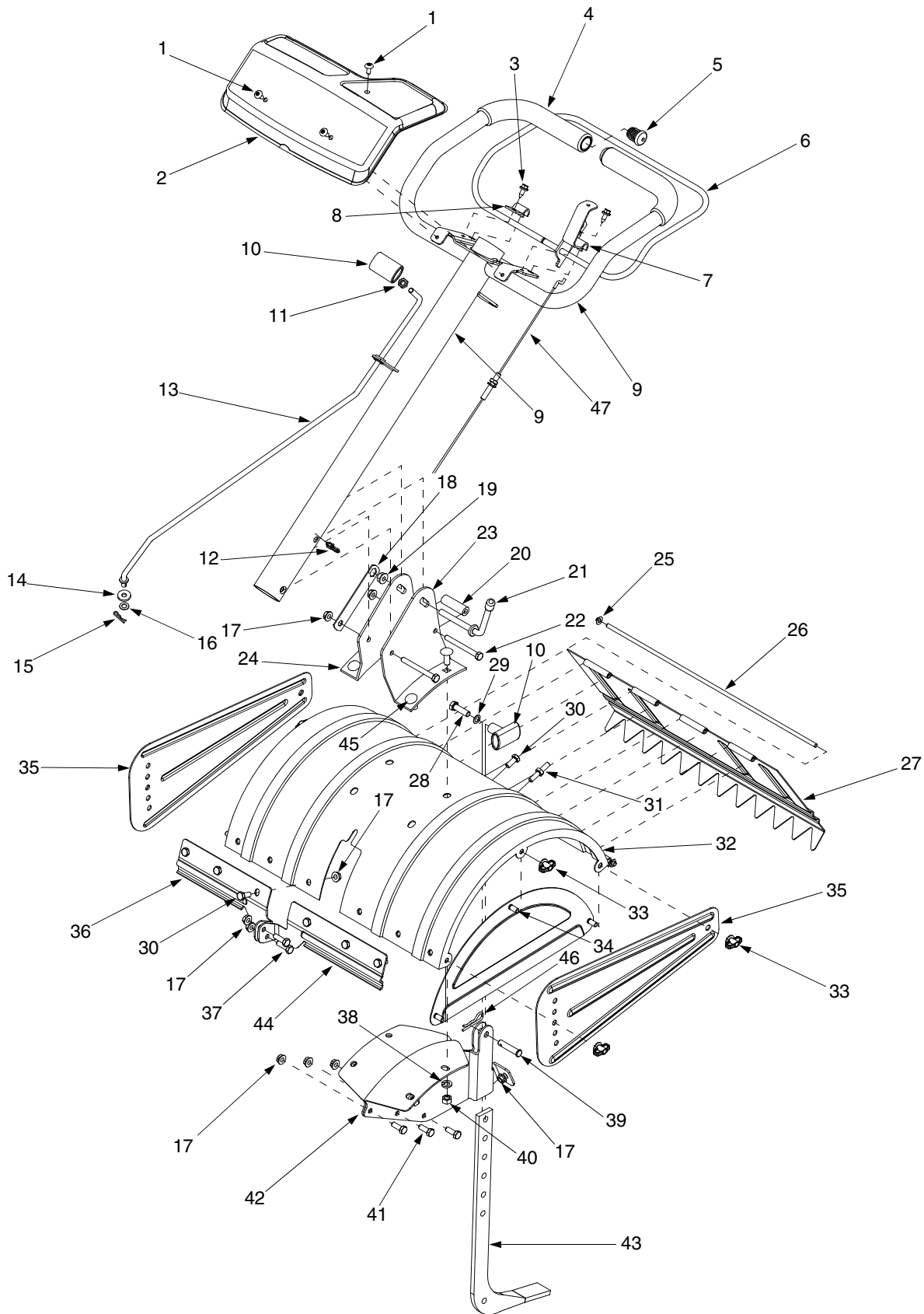

## Model Series 410

| Ref. No. | Part No.  | Part Description              | Ref. No. | Part No.  | Part Description             |
|----------|-----------|-------------------------------|----------|-----------|------------------------------|
| 1.       | 710-1017  | Tap Screw 1/4-14 x.625        | 25.      | 726-0106  | Cap Nut                      |
| 2.       | 786-0131  | Handle Cover w/o Throttle     | 26.      | 747-0432  | Rod                          |
| 3.       | 710-0896  | Hex Washer Screw 1/4-14 x.625 | 27.      | 786-0113  | Rear Tine Shield Flap        |
| 4.       | 720-0278A | Foam Grip                     | 28.      | 710-3005  | Hex Cap Screw 3/8-16 x 1.25  |
| 5.       | 735-0246A | End Plug                      | 29.      | 736-0117  | Flat Washer.375 ID x.620 OD  |
| 6.       | 647-0014  | Clutch Control Assembly       | 30.      | 710-3008  | Hex Cap Screw 5/16-18 x.75   |
| 7.       | 786-0118  | Return Bracket - LH           | 31.      | 738-0849  | Hex Screw 5/16-18 x.75       |
| 8.       | 786-0098  | Return Bracket - RH           | 32.      | 786-0085  | Tine Shield                  |
| 9.       | 649-0017  | Handle Assembly               | 33.      | 712-0421  | Wing Nut                     |
| 10.      | 720-0210A | Knob                          | 34.      | 686-0044A | End Cover Assembly           |
| 11.      | 712-3008  | Jam Nut 3/8-16                | 35.      | 786-0090  | Side Shield                  |
| 12.      | 726-0330  | Cable Clip                    | 36.      | 786-0076  | Shield Bracket RH            |
| 13.      | 747-0902  | Shift Control                 | 37.      | 710-0376  | Hex Cap Screw 5/16-18 x 1.0  |
| 14.      | 735-0127  | Rubber Washer.33 ID x.87 OD   | 38.      | 736-0169  | Lock Washer 3/8              |
| 15.      | 714-0104  | Cotter Pin                    | 39.      | 711-0415  | Clevis Pin                   |
| 16.      | 736-0204  | Flat Washer.344 ID x.62 OD    | 40.      | 712-3017  | Hex Nut 3/8-16               |
| 17.      | 712-04063 | Hex Flange Lock Nut 5/16-18   | 41.      | 710-3038  | Hex Cap Screw 5/16-18 x.875  |
| 18.      | 784-0191  | Retainer Bracket              | 42.      | 686-0043A | Tine Shield Bracket Assembly |
| 19.      | 712-0379  | Flange Lock Nut 3/8-24        | 43.      | 786-0120  | Depth Stake                  |
| 20.      | 750-0885A | Spacer.322 ID x.625 OD        | 44.      | 786-0077  | Shield Bracket - LH          |
| 21.      | 784-0190  | Handle Adjustment Crank       | 45.      | 710-3097  | Carriage Bolt 3/8-16 x 1.0   |
| 22.      | 710-0189  | Hex Screw 5/16-18 x 3.0       | 46.      | 714-0147  | Cotter Pin                   |
| 23.      | 786-0109  | Handle Mounting Bracket - LH  | 47.      | 746-0916  | Clutch Cable                 |
| 24.      | 786-0108  | Handle Mounting Bracket - RH  |          |           |                              |

**NOTE:** For **painted parts**, please refer to the list of color codes below. Please add the applicable color code, wherever needed, to the part number to order a replacement part. For instance, if a part numbered 700-xxxx is painted Oyster Gray, the part number to order would be 700-xxxx-0662.

Black — 0691; Black, Powder — 0637; Blue, Midnight — 0667; Charcoal — 0483; Grey — 0648;  
 Grey, Oyster — 0662; Orange — 0606; Red — 0650; Red, MTD — 0638; Silver — 0629; Yellow — 0674.

## **NOTES**

## **NOTES**

# MANUFACTURER'S LIMITED WARRANTY FOR:



The limited warranty set forth below is given by MTD LLC with respect to new merchandise purchased and used in the United States, its possessions and territories.

"MTD" warrants this product against defects in material and workmanship for a period of two (2) years commencing on the date of original purchase and will, at its option, repair or replace, free of charge, any part found to be defective in materials or workmanship. This limited warranty shall only apply if this product has been operated and maintained in accordance with the Operator's Manual furnished with the product, and has not been subject to misuse, abuse, commercial use, neglect, accident, improper maintenance, alteration, vandalism, theft, fire, water, or damage because of other peril or natural disaster. Damage resulting from the installation or use of any part, accessory or attachment not approved by MTD for use with the product(s) covered by this manual will void your warranty as to any resulting damage.

Normal wear parts are warranted to be free from defects in material and workmanship for a period of thirty (30) days from the date of purchase. Normal wear parts include, but not limited to items such as: batteries, belts, blades, blade adapters, grass bags, rider deck wheels, seats, snow thrower skid shoes, shave plates, auger spiral rubber and tires.

**HOW TO OBTAIN SERVICE:** Warranty service is available, WITH PROOF OF PURCHASE, through your local authorized service dealer. To locate the dealer in your area, check your Yellow Pages, or contact MTD LLC at P.O. Box 361131, Cleveland, Ohio 44136-0019, or call 1-800-800-7310 or 1-330-220-4683 or log on to our Web site at [www.mtdproducts.com](http://www.mtdproducts.com).

This limited warranty does **not** provide coverage in the following cases:

- a. The engine or component parts thereof. These items may carry a separate manufacturer's warranty. Refer to applicable manufacturer's warranty for terms and conditions.
- b. Log splitter pumps, valves, and cylinders have a separate one year warranty.
- c. Routine maintenance items such as lubricants, filters, blade sharpening, tune-ups, brake adjustments, clutch adjustments, deck adjustments, and normal deterioration of the exterior finish due to use or exposure.
- d. Service completed by someone other than an authorized service dealer.

- e. MTD does not extend any warranty for products sold or exported outside of the United States, its possessions and territories, except those sold through MTD's authorized channels of export distribution.
- f. Replacement parts that are not genuine MTD parts.
- g. Transportation charges and service calls.

**No implied warranty, including any implied warranty of merchantability of fitness for a particular purpose, applies after the applicable period of express written warranty above as to the parts as identified. No other express warranty, whether written or oral, except as mentioned above, given by any person or entity, including a dealer or retailer, with respect to any product, shall bind MTD. During the period of the warranty, the exclusive remedy is repair or replacement of the product as set forth above.**

**The provisions as set forth in this warranty provide the sole and exclusive remedy arising from the sale. MTD shall not be liable for incidental or consequential loss or damage including, without limitation, expenses incurred for substitute or replacement lawn care services or for rental expenses to temporarily replace a warranted product.**

Some states do not allow the exclusion or limitation of incidental or consequential damages, or limitations on how long an implied warranty lasts, so the above exclusions or limitations may not apply to you.

In no event shall recovery of any kind be greater than the amount of the purchase price of the product sold. **Alteration of safety features of the product shall void this warranty.** You assume the risk and liability for loss, damage, or injury to you and your property and/or to others and their property arising out of the misuse or inability to use the product.

This limited warranty shall not extend to anyone other than the original purchaser or to the person for whom it was purchased as a gift.

**HOW STATE LAW RELATES TO THIS WARRANTY:** This limited warranty gives you specific legal rights, and you may also have other rights which vary from state to state.

**IMPORTANT:** Owner must present Original Proof of Purchase to obtain warranty coverage.

**MTD LLC, P.O. BOX 361131 CLEVELAND, OHIO 44136-0019; Phone: 1-800-800-7310, 1-330-220-4683**



## Free Manuals Download Website

<http://myh66.com>

<http://usermanuals.us>

<http://www.somanuals.com>

<http://www.4manuals.cc>

<http://www.manual-lib.com>

<http://www.404manual.com>

<http://www.luxmanual.com>

<http://aubethermostatmanual.com>

Golf course search by state

<http://golfingnear.com>

Email search by domain

<http://emailbydomain.com>

Auto manuals search

<http://auto.somanuals.com>

TV manuals search

<http://tv.somanuals.com>