

\$1.00

OWNER'S GUIDE

ASSEMBLY • OPERATION • MAINTENANCE • PARTS

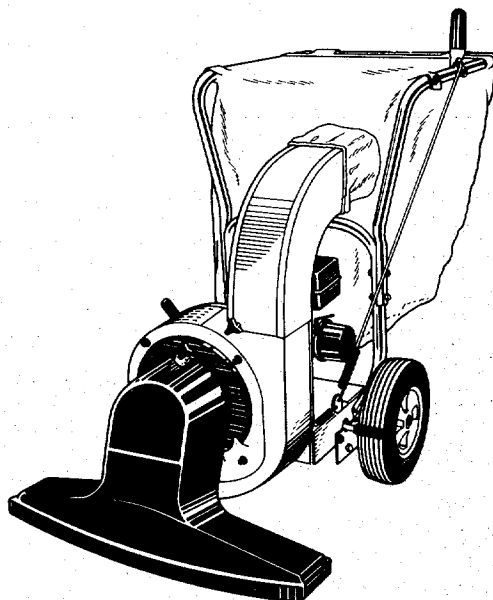

**POWER
VACUUMS**

Model Numbers

SAME AS 677 MINUS TOW BAR
→ 240-675-000-PUSH

240-685-000

240-689-000

240677

240687

Important: Read Safety Rules and Instructions Carefully

INDEX

Safe Operation Practices	3	Maintenance	10
Assembly Instructions	4	Off-Season Storage	
Operation	9	Illustrated Parts	12, 14
Adjustments	9	Replacement Parts List	13, 15
Lubrication	10		



Instructions given with this symbol are for personal safety. Be sure to follow them.



This unit is equipped with an internal combustion engine and should not be used on or near any unimproved forest-covered, brush-covered or grass-covered land unless the engine's exhaust system is equipped with spark arrester meeting applicable local or state laws (if any). If a spark arrester is used, it should be maintained in effective working order by the operator.

In the State of California the above is required by law (Section 4442 of the California Public Resources Code). Other states may have similar laws. Federal laws apply on federal lands. A spark arrester for the muffler is available through your nearest engine authorized service center.



IMPORTANT

It is suggested that this manual be read in its entirety before attempting to assemble or operate. Keep this manual in a safe place for future reference and for ordering replacement parts.

This unit is shipped WITHOUT GASOLINE or OIL. After assembly, see separate engine manual for proper fuel and engine oil recommendations.

SAFE OPERATION PRACTICES FOR POWER VACUUMS

1. Read this operating and service instructing manual carefully. Be thoroughly familiar with the controls and proper use of the power vacuum.
2. Never allow children to operate this power vacuum.
3. Keep the area of operation clear of all persons, particularly small children and pets.
4. Check fuel before starting engine. Do not fill fuel tank indoors, when engine is running, or while engine is hot. Wipe off any spilled fuel before starting engine.

Do not change engine governor settings.
6. Do not put hands near rotating parts for any reason.
7. If the power vacuum should start to vibrate abnormally, stop the engine and check immediately for the cause. Vibration is generally a warning of trouble.
8. Before cleaning, repairing or inspecting, make certain all moving parts have come to a complete stop. Disconnect spark plug wire and keep wire away from plug to prevent accidental starting. Also keep throttle control lever in the stop position.
9. If the power vacuum should become blocked with debris at any point, shut engine off and wait until the impeller comes to a complete stop before attempting to remove the obstruction. Disconnect spark plug wire to prevent accidental starting.
10. Check all bolts for tightness at frequent periods.
11. Never store this power vacuum with fuel in the tank. Allow engine to cool before storing in any enclosure.
12. Keep bag and equipment free of debris when not in use.
13. Never operate this power vacuum unless air duct and vacuum bag are properly affixed in their place. Large zippered end of bag must be closed when operating to prevent objects from being blown out.
14. Never empty vacuum bag when engine is running.
15. Never change inlet nozzle or auxiliary hose attachment when engine is running.
16. The manufacturer recommends that the operator wear safety glasses or some other suitable eye protection when operating this machine.
17. Check the vacuum bag frequently for wear and replace when necessary.
18. Never operate as a leaf blower unless impeller guard and guard assembly are properly affixed in their place.
19. Exercise caution whenever operating as a leaf blower. Do Not allow discharge to be pointed in the direction of persons.
20. No one should operate this unit while intoxicated or while taking medication that impairs the senses or reactions.

ASSEMBLY INSTRUCTIONS

CONTENTS OF HARDWARE PACK (See figure 1)

- A (1) Clutch Grip Assembly*
- B (1) Hairpin Clip*
- C (1) Clevis Pin*
- D (1) Extension Spring*
- E (1) Lock Nut 1/4-20 Thread*
- F (3) Hand Knobs
- G (3) Belleville Washers
- I (4) Hex Bolt 1/4-20 x 1.75" Long
- J (4) Hex Lock Nuts 1/4-20 Thread
- K (2) Stud Pins
- L (2) Push-on Speed Nuts
- M (1) Hex Jam Nut 1/4-20 Thread*

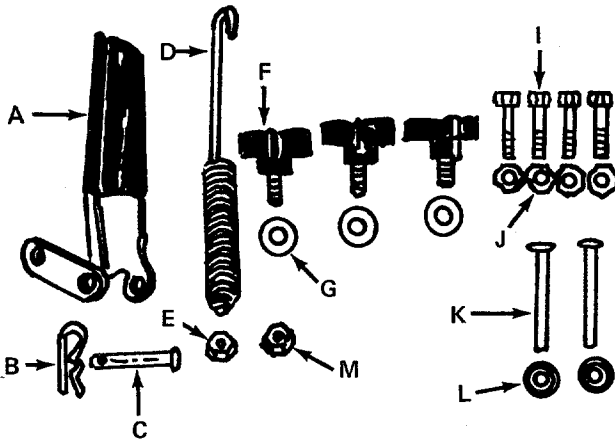

FIGURE 1

LOOSE PARTS IN CARTON (See figure 2)

- N (1) Nozzle
- O (1) Upper Handle
- P (1) Air Duct Assembly
- Q (1) Clutch Rod*
- R (1) Directional Discharge Assembly
- S (1) Impeller Guard
- T (1) Bag

*Self-Propelled Models Only.

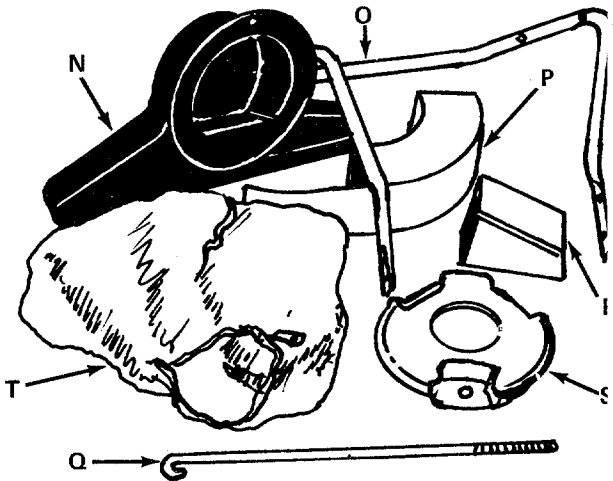

FIGURE 2

TOW BAR KIT- Standard with push models. (See figure 3) Optional with self-propelled models

- U (2) Hex Bolts 5/16-18 x 1.00" Long
- V (4) Shoulder Spacers
- W (2) Hex Nut 5/16-18 Thread
- X (1) Truss Machine Screw 1/4-20 x .75" Long
- Y (1) Lock Washer 1/4" I.D.
- Z (1) Hex Nut 1/4-20 Thread
- AA (1) Shoulder Bolt
- AB (2) Belleville Washers 3/8" I.D.
- AC (1) Hex Jam Lock Nut 3/8-16 Thread
- (2) Tow Bar Halves (Not Shown)

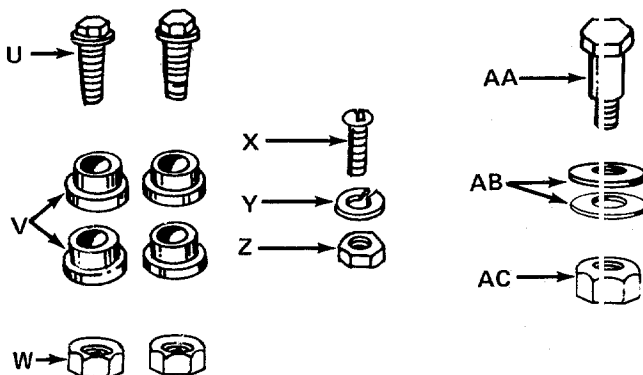
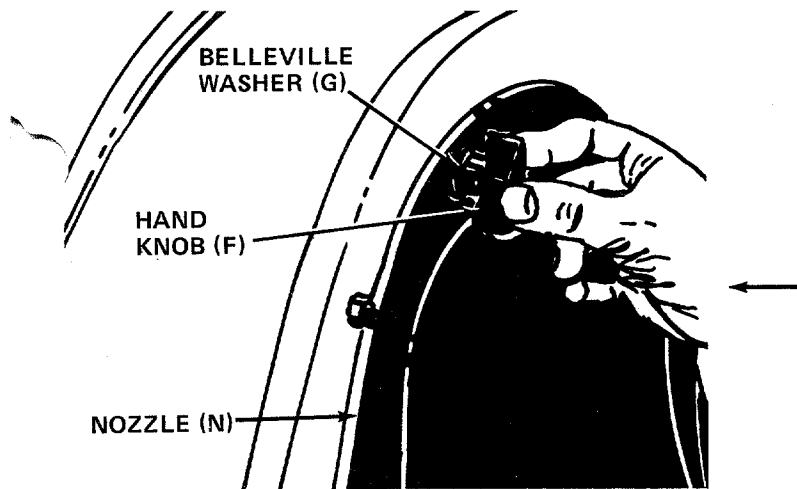
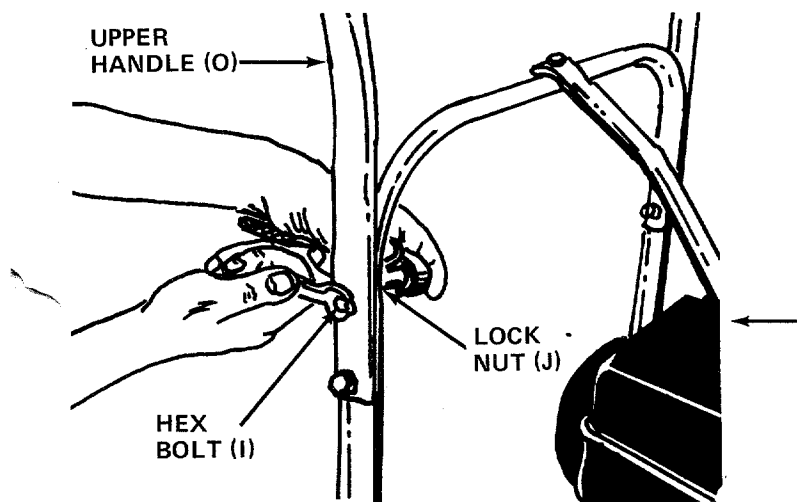

FIGURE 3



1. Place nozzle (N) in position on front of housing so that it rests in flanges. Secure with one hand knob (F) and Belleville washer (G). See figure 4.

FIGURE 4



2. Place the upper handle (O) in position over lower handle. Fasten with four hex bolts (I) and lock nuts (J) provided. See figure 5. Two 7/16" wrenches are required.

FIGURE 5

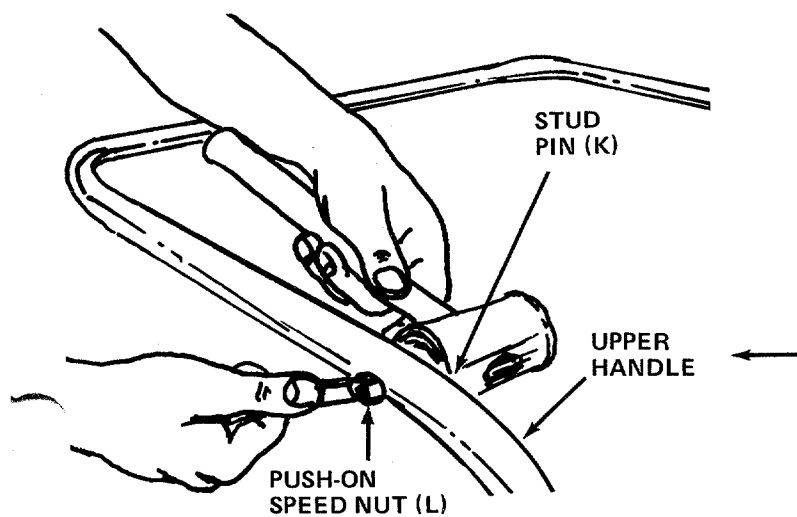

3. Place the stud pins (K) in holes in upper handle (head of pins go to the inside of handle). Secure pins with push-on speed nuts (L) by holding speed nut with box wrench and tapping pin with hammer. See figure 6.

FIGURE 6

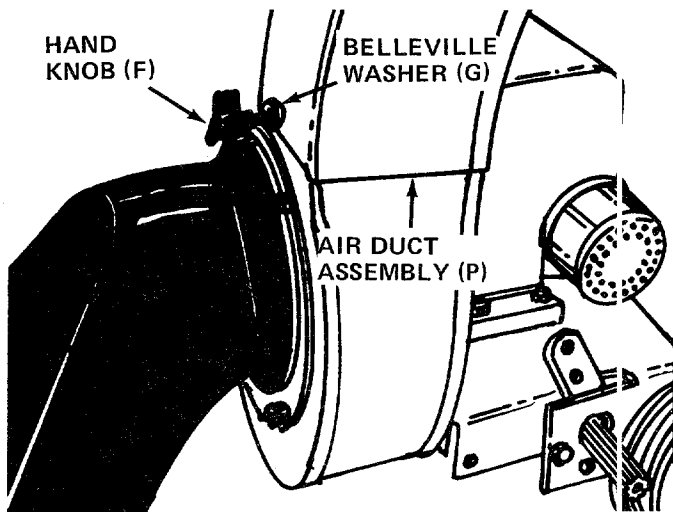

- Place air duct assembly (P) over opening on top of housing. Secure with two hand knobs (F) and Belleville washer (G). See figure 7.

FIGURE 7

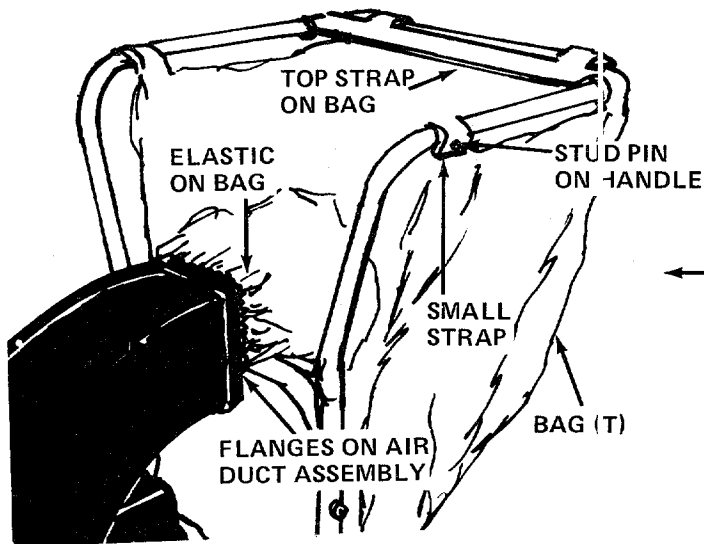

- Assemble the bag by slipping the top straps on bag (T) over upper handle. Hook two small straps over stud pins on handle. Slip elastic opening of bag over air duct assembly. See figure 8.



Be certain elastic on bag is placed over the flanges on air duct assembly.

FIGURE 8

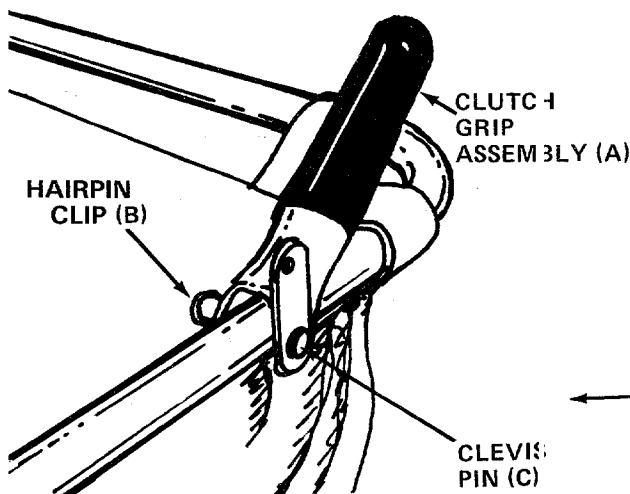

Steps 6, 7, 8 and 9 are for self-propelled units only.

- Assemble the clutch grip (A) to the left hand side of upper handle. Secure in place with clevis pin (C) and hairpin clip (B). See figure 9. Head of clevis pin should be to the outside of handle.

FIGURE 9

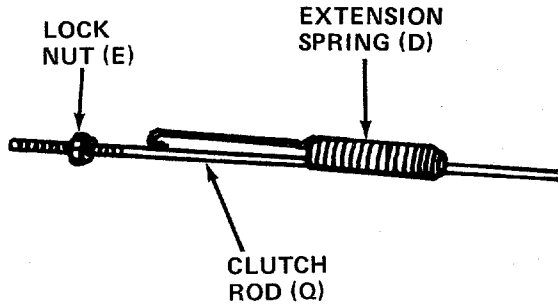

- Slide the extension spring (D) onto clutch rod (Q) as shown in figure 10. Thread lock nut (E) onto clutch rod approximately 2-1/2 inches.

FIGURE 10

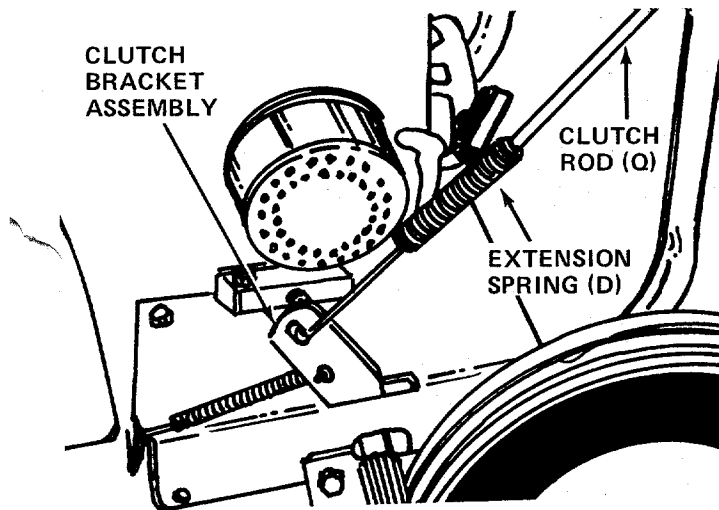

- Hook top (hooked end) of clutch rod into clutch grip. Hook spring into clutch bracket assembly. See figure 11. Spring should not have any slack. Adjust nut so that when the clutch grip is all the way up, there is no slack in the spring.
- Thread hex jam nut (M) onto clutch rod, and lock it against the lock nut (E).

FIGURE 11

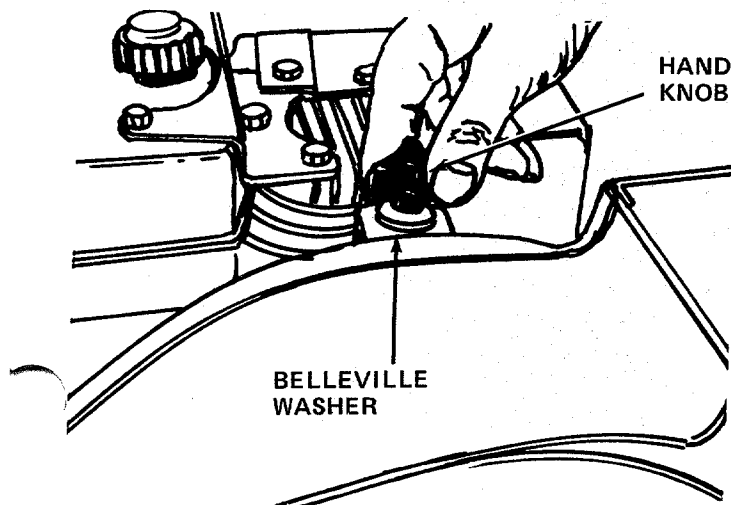

FIGURE 12

ASSEMBLY INSTRUCTIONS

To Convert from a Vacuum to a Leaf Blower.



Engine must be stopped (off) and spark plug wire disconnected.

- Remove the bag.
- Remove the air duct assembly by removing two hand knobs and belleville washers.
- Remove the nozzle by removing one hand knob and belleville washer.
- Remove the hand knob and belleville washer holding the housing to engine brace. See figure 12.

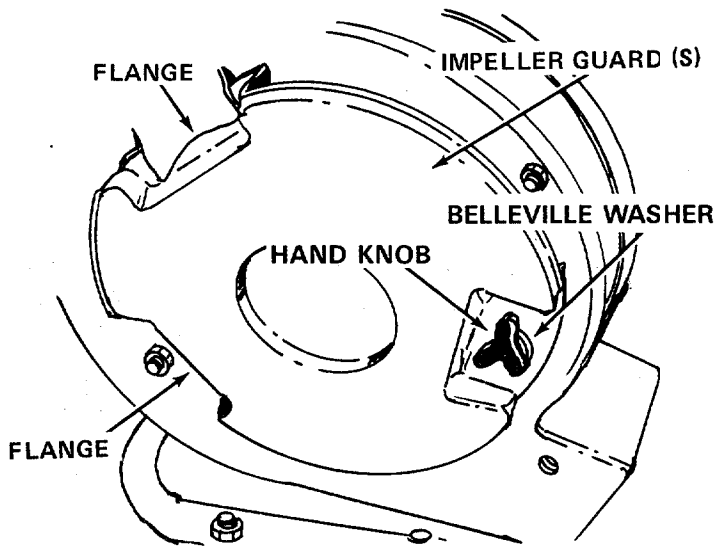

FIGURE 13

5. Lift up and out on the housing and rotate it 105° clockwise. Chute opening should be to the right hand side when viewed from the front of unit. See figure 13.
6. Place the impeller guard (S) into flanges on front of housing. Line up hole in guard with hole on housing. Secure with one hand knob and belleville washer. See figure 13.

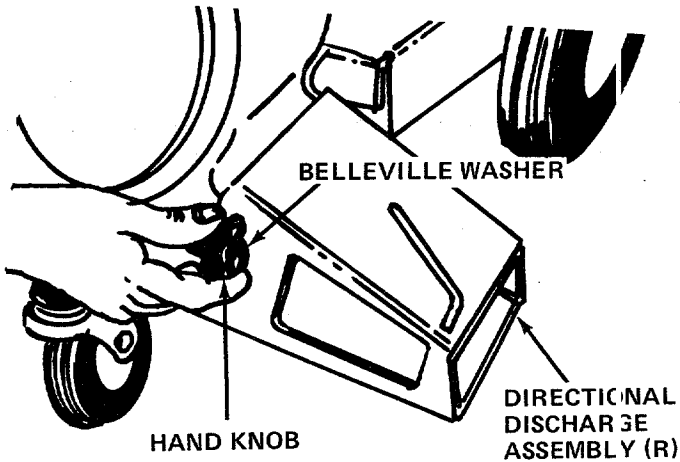

FIGURE 14

7. Place the directional discharge assembly (R) over chute opening. Secure with two hand knobs and belleville washers. See figure 14.

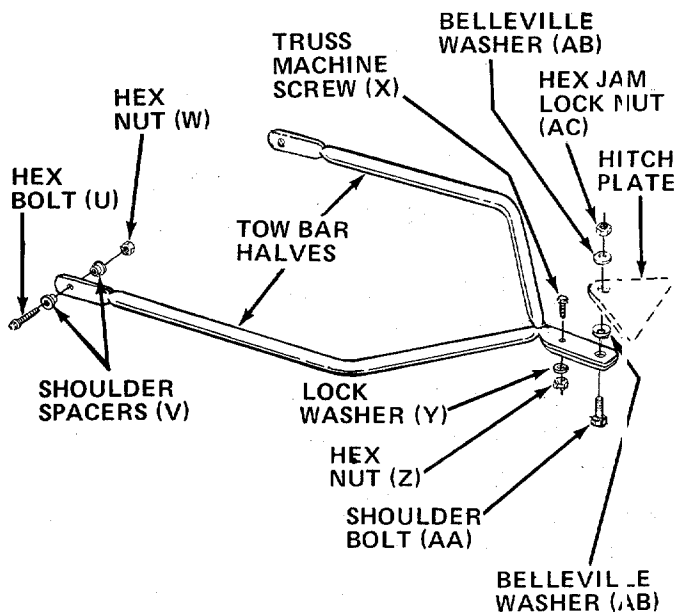

FIGURE 15

ASSEMBLY INSTRUCTIONS for Tow Bar Kit (Optional)

1. Remove the self-tapping screws on each side of frame. Refer to drawing on page 12, reference number 42.
2. Place two bar halves in position on frame. Place one shoulder spacer (V) between frame and tow bar. Next, place shoulder spacer (V) and hex bolt (U) through tow bar and frame. Secure with hex nut (W). See figure 15. Repeat for other side.
3. Secure the two tow bar ends together with truss machine screw (X), lock washer (Y) and hex nut (Z). See figure 15.

To attach the tow bar to a hitch, place the shoulder bolt (AA) up through the tow bar. Place one belleville washer (AB) on the shoulder bolt, then the hitch plate and the other belleville washer. Cupped side of the washers must be against the hitch plate. Secure with hex jam lock nut (AC). See figure 15.

OPERATION

BEFORE STARTING ENGINE

Service engine with gas and oil. See engine manual packed with vacuum for complete instructions for care and maintenance of engine. READ DIRECTIONS CAREFULLY.



CAUTION
REVOLVING BLADES-KEEP
HANDS AWAY FROM ALL
OPENINGS

3450

TO START ENGINE

After the engine has been properly fueled and oiled (refer to engine operating and maintenance instructions), start engine following the instructions below.

1. Move choke lever on engine to CHOKE position.



NOTE

A warm engine may not require choking.

2. Move throttle control lever on engine to FAST position.
3. Crank engine by pulling recoil starter with a quick, firm stroke. Do not pull out so far the rope stops with a jerk. Do not allow rope and handle to snap back into place.
4. After two or three full firm pulls on recoil (or as soon as engine fires), move choke control to RUN position.
5. **Self-Propelled Models Only** - To engage the drive mechanism, squeeze the clutch grip against the upper handle. Release the clutch grip to stop the forward motion.

TO STOP ENGINE

1. To stop engine, move throttle control lever to OFF position.
2. Disconnect spark plug wire and ground to prevent accidental starting while equipment is unattended.

Operate a new engine at intermediate speeds and light load for the first few hours as you would a new automotive engine.



IMPORTANT

The vacuum bag may have an air escape located on the upper right hand side. See figure 16. The air escape can be opened if the vacuum is operated in wet, sandy or muddy conditions.

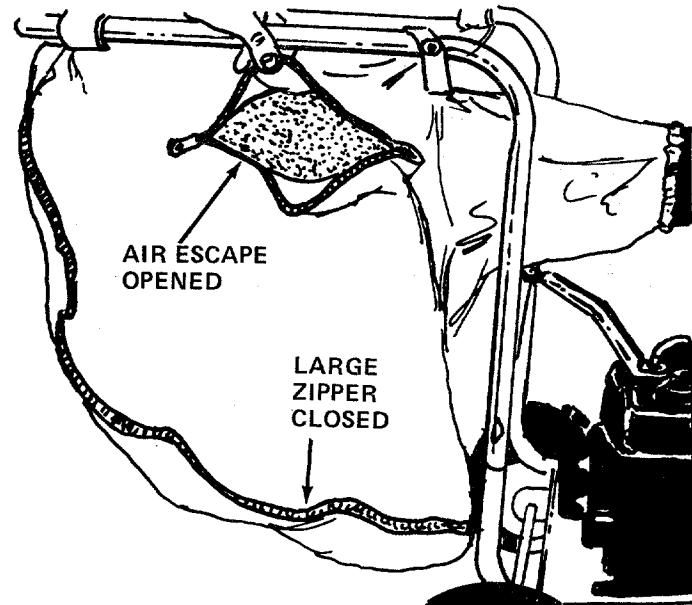

FIGURE 16

ADJUSTMENTS



CAUTION

Do not at any time make any adjustment to the unit without first stopping engine and disconnecting spark plug wire.

HEIGHT ADJUSTMENT

The height adjustment crank is located on the right hand side of the vacuum. See figure 17. Turn the crank clockwise to raise the nozzle. Turn the crank counter-clockwise to lower.

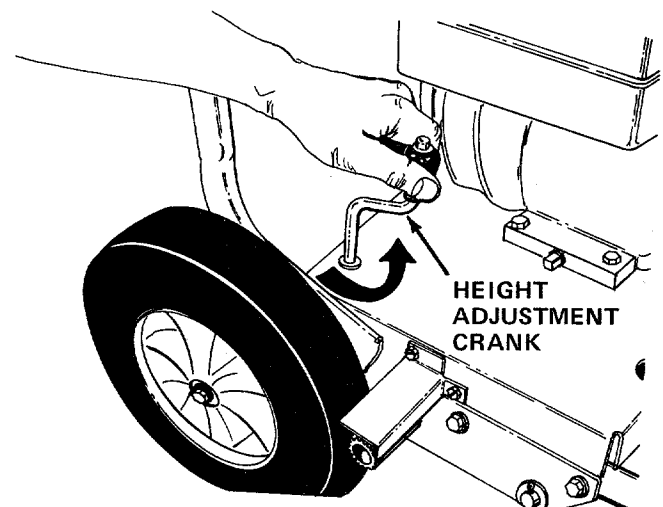

FIGURE 17

CARBURETOR ADJUSTMENT



WARNING

If any adjustments are made to the engine while the engine is running (e.g. carburetor), disengage all clutches. Keep clear of all moving parts. Be careful of heated surfaces and muffler.

If carburetor needs adjustment to start or for operation, see "Carburetor Adjustment" section of engine manual.

CLUTCH ROD ADJUSTMENT (Self-Propelled Models Only)

To adjust the clutch rod, refer to step numbers 8 and 9 under assembly instructions.

LUBRICATION

Wheels - Rear wheels are provided with oil lite bearings. Place a few drops of SAE 30 oil on each bearing once a season.

Gear Box (Self-Propelled Models Only). The gear box is lubricated with 2 ounces of High Temp. (450° F.) grease. Order part number 737-0133. Periodically check lubricant level by removing the two self-tapping screws on the gear box cover and lifting off the cover. Do not change grease; simply add if necessary.

MAINTENANCE



WARNING

Disconnect spark plug wire and ground it against the engine before performing any repairs or maintenance.

BELT REPLACEMENT (Self-Propelled Models Only)

1. Remove the nozzle or impeller guard from front of blower housing.
2. Remove hex bolt and lock washer from center of impeller. See figure 18. A 9/16" socket wrench with extension is needed.
3. Remove hand knob and Belleville washer from top of housing.
4. Remove two self-tapping screws which hold the belt guard. See figure 19. A 3/8" wrench is required. Lift off belt guard.

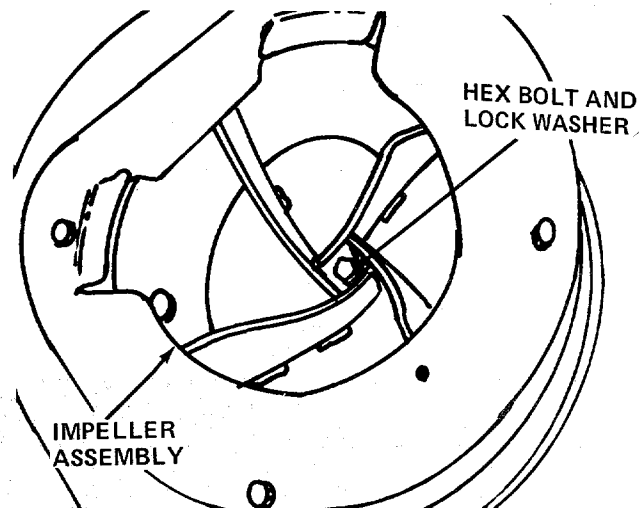

FIGURE 18

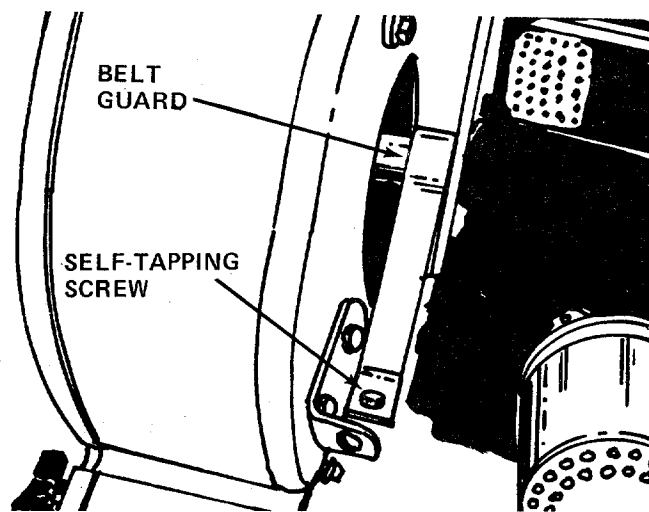

FIGURE 19

5. Slide belt off the impeller pulley. Slide housing and impeller off engine crankshaft. Be careful to not lose square key. See figure 20.

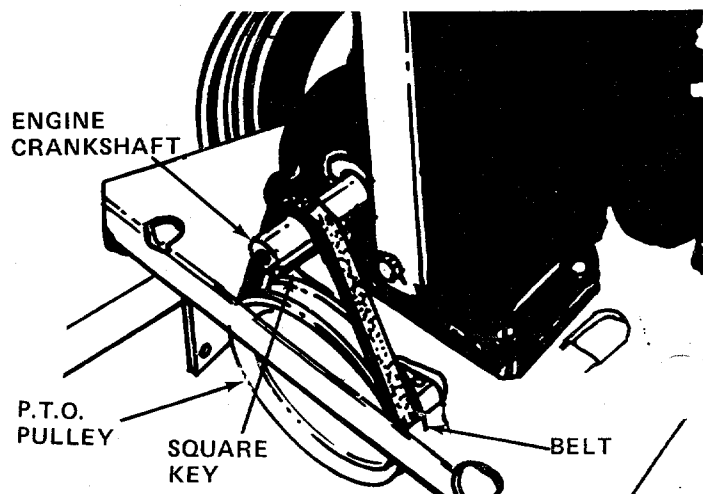

FIGURE 20

6. Slide impeller and blower housing assemblies off crankshaft.
7. Remove belt from P.T.O. pulley and install new belt. See figure 20.



When reassembling the new belt, the aid of another person will be helpful.

8. Turn the crankshaft until the key way on shaft is directly on top. While holding housing assembly and impeller assembly, line up the key way on the pulley with the key on the crankshaft, and slide housing and impeller assemblies onto crankshaft.
9. Secure impeller to crankshaft with hex bolt and lockwasher, removed in step 2. Tighten securely.
10. Slip belt over impeller pulley and reassemble the belt guard.
11. Secure blower housing with hand knob and washer.
12. Reassemble the nozzle or impeller guard.



When storing any type of power equipment in an unventilated or metal storage shed, care should be taken to rustproof the equipment. Using a light oil or silicone, coat the equipment, especially springs and bearings.

OFF-SEASON STORAGE

The following steps should be taken to prepare the unit for storage.

1. Clean the engine and the entire unit thoroughly.
2. Refer to engine manual for correct engine storage instructions.
3. Store unit in a clean, dry area.

TROUBLE SHOOTING CHART

PROBLEM	CAUSE	REMEDY
1. Excessive vibration.	A. Bent crankshaft. B. Vane plate out of balance.	A. Replace crankshaft (should be done by an authorized service dealer). B. Replace vane plate.
2. Height adjustment slips out of lockout position.	Handle bent.	Replace index handle and index plate.
3. Engine fails to start.	A. Check fuel tank for gas. B. Spark plug lead wire disconnected. C. Faulty spark plug.	A. Fill tank if empty. B. Connect lead wire. C. Clean, adjust gap or replace.
4. Hard starting or loss of power.	A. Spark plug wire loose. B. Dirty air cleaner.	A. Connect and tighten spark plug wire. B. Clean air cleaner as described in engine manual.
5. Engine overheats.	A. Carburetor not adjusted properly. B. Air flow restricted. C. Engine oil level low.	A. Adjust carburetor. See engine manual. B. Remove blower housing on engine and clean as described in the engine manual. C. Fill crankcase with the proper oil.

NOTE: For repairs beyond the minor adjustments listed above, please contact your local service dealer.

Models 675, 685 and 689

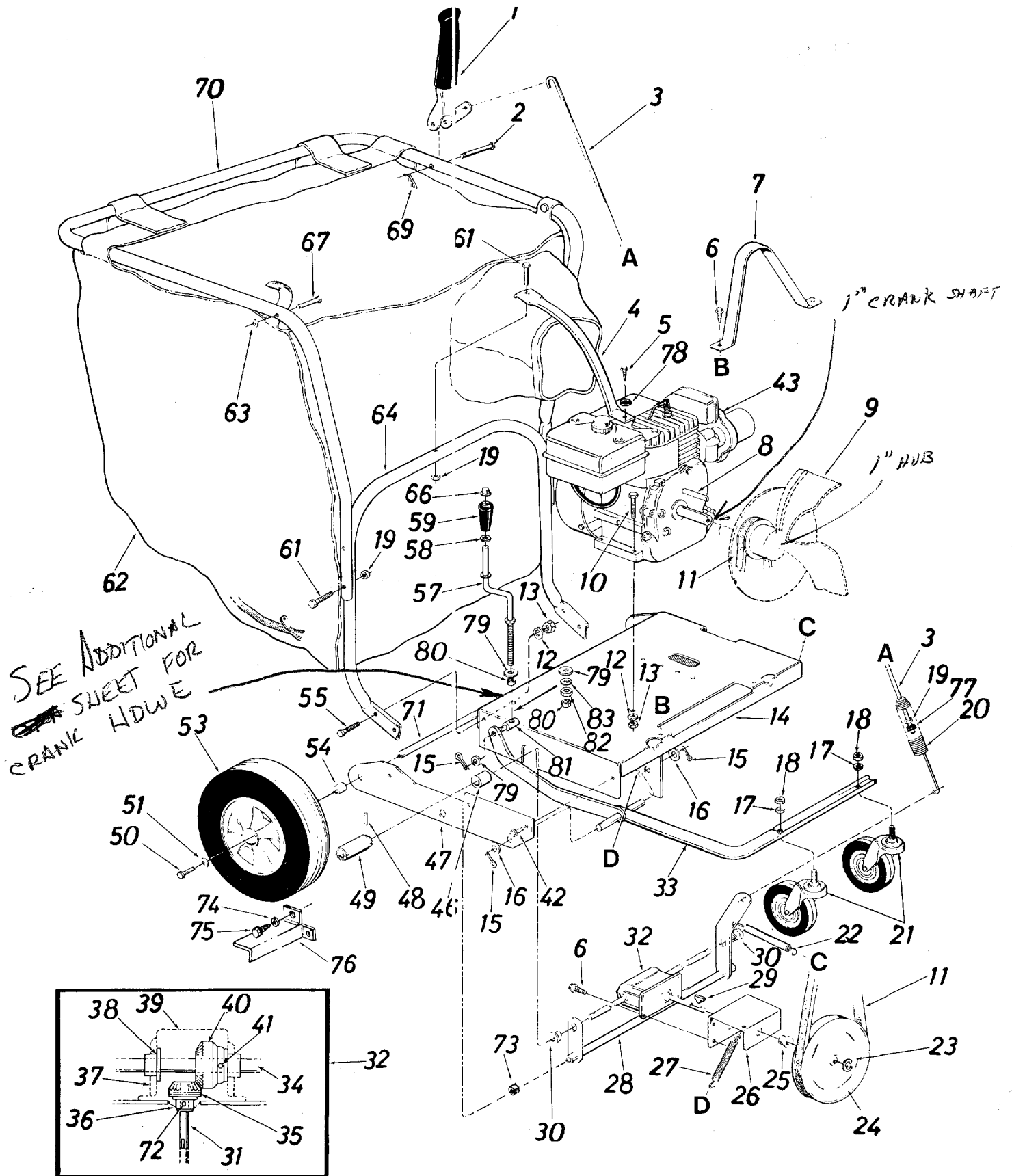

Models 675,685 and 689

PARTS LIST FOR MODELS 675, 685, 689, 240677 and 240687 POWER VACUUMS

REF. NO.	PART NO.	COLOR CODE	DESCRIPTION	New Part	REF. NO.	PART NO.	COLOR CODE	DESCRIPTION	New Part
1	05778		Clutch Grip Ass'y.†		41	715-0246		Spring Pin Spiral 3/16" Dia. x 1.25" Lg.†	
2	711-0679		Clevis Pin .375" Dia. x 1.88"†		42	710-0726		Hex Wash. Hd. "AB" Tap Scr. 5/16" x .75" Lg.	
3	747-0154		Clutch Rod 32" Lg.†		43	-----		Engine	
4	749-0787		Handle Brace (Painted)		46	748-0201		Spacer .63 I.D. x .88" O.D. x .56" Lg †	
	749-0482		Handle Brace (Chrome)		47	14530-638		Side Plate	
5	-----		Part of Engine		48	715-0247		Spring Pin Spiral 3/16" Dia. x 1.0" Lg. †	
6	710-0892		Hex L-Wash. Hd. AB Tap Scr. 1/4" x .62" Lg.†		49	748-0288		Drive Pinion†	
7	14558		Belt Guard†		50	710-0170		Hex Locking Bolt 5/16-24 x .62" Lg.	
8	714-0114		Square Key 1/4" x 2.0" Lg.		51	736-0159		Fl-Wash. .34" I.D. x .87" O.D.	
9	14536A		Air Vane Plate Ass'y. (675 and 677)	N	53	734-1035		Wheel Ass'y-Comp. 12" x 3" (Incl. Ball Bearings)	
	14557A		Air Vane Plate Ass'y w/pulley†			734-1184		Wheel Ass'y. Comp. 10.5" x 4" (677 Only)	
10	710-0442		Hex Bolt 5/16-18 x 1.5" Lg.*			741-0313		Bearings (677 Only)	
11	754-0219		"V"-Belt†		54	750-0194		Spacer .63" I.D. x 1.0" O.D. x .94" Lg. (675,685,687)	
12	736-0119		L-Wash. 5/16" I.D.			748-0192		Spacer .63" I.D. x .878" O.D. x .79" Lg. (677)	
13	712-0267		Hex Nut 5/16-18 Thd.*		55	710-0118		Hex Bolt 5/16-18 x .75" Lg.*	
14	16454		Engine Mounting Frame Ass'y.		57	747-0542		Height Adjustment Crank	
15	714-0115		Cotter Pin 1/8" Dia. x 1.0" Lg.*		58	736-0117		Fl-Wash. .385" I.D. x .62" O.D.	
16	736-0187		Fl-Wash. .63" I.D. x 1.25" O.D.		59	720-0171		Crank Knob	
17	736-0921		L-Wash. 1/2" I.D.*		61	710-0136		Hex Bolt 1/4-20 x 1.75" Lg.	
18	712-0206		Hex Nut 1/2-13 Thd.*		62	764-0162A		Vacuum Bag - Felt	
19	712-0107		Hex Cent. L-Nut 1/4-20 Thd.		63	1539-019		Push Speed Nut .25" Dia. Stud	
20	732-0411		Extension Spring .78" O.D. x .75" Lg.†		64	749-0785		Lower Handle (Painted)	
21	734-1036		Swivel Caster Wheel 5" Dia. x 1.25"			749-0481		Lower Handle (Chrome)	
22	732-0409		Extension Spring .38" O.D. x 7.50" Lg.†		66	726-0100		Push Nut 3/8" Dia.	
23	716-0104		Snap "E"-Ring .50" Dia. Shaft†		67	711-0737		Stud Pin .250" Dia. x 1.75"	
24	756-0367		"V"-Pulley 5/8" x 6.50" O.D.†		69	714-0145		Internal Cotter Pin 3/8" Dia.	
25	748-0142		Flange Bearing .502" I.D.†		70	749-0786		Upper Handle (Painted)	
26	14570		Gear Box Mounting Bracket†			749-0480		Upper Handle (Chrome)	
27	732-0376		Extension Spring .75" O.D. x 3.28" Lg.†		71	738-0185		Rear Axle .624" Dia. x 24.37"	
28	14565		Clutch Bracket Ass'y.†		72	715-0249		Spring Roll Pin 5/32" Dia. x 1.12" Lg	
29	714-0229		#2 Woodruff Key 3/32" Dia. x .81" Lg.†		73	750-0142		Spacer .82" I.D. x 1.0" O.D. x .305 Lg.†	
30	748-0227		Hex Flange Bearing Bronze .625" I.D.†		74	736-0175		L-Wash. .265" I.D.†	
31	738-0516		Pinion Shaft .50" Dia. x 5.0"†		75	710-0352		Hex Self Tap Scr. 1/4" x 3/8" Lg.†	
32	717-0493		Gear Box Ass'y. Comp.†		76	14556		R.H. Pinion Guard†	
33	16273		Caster Arm Ass'y.			14555		L.H. Pinion Guard (Not Shown)	
34	08348		Drive Shaft .624" Dia. x 22.75" Lg.†		77	712-0298		Hex Jam Nut 1/4-20 Thd.†	
35	748-0136		Bevel Gear .50" I.D. x 14 Teeth		78	736-0242		Belleville Washer	
36	748-0108		Flange Bearing .503" I.D.†		79	736-0300		Fl-Wash. .35" I.D. x .87" O.D.	
37	08189		Gear Box†		80	750-0528		Spacer .38" I.D. x .50" O.D. x .180" Lg	
38	748-0110		Flange Bearing .630" I.D.†		81	711-0797		Ferrule 3/8-8 x .38" Dia.	
39	08187		Gear Box Cover†		82	712-0354		Hex Nut 3/8-8 Thd.	
40	748-0135		Bevel Gear .62" I.D. x 28 Teeth†		83	736-0169		L-Wash. 3/8" I.D.*	

Parts for Self-Propelled Units (Models 685, 698 and 240687) only.

Models 675, 685 and 689

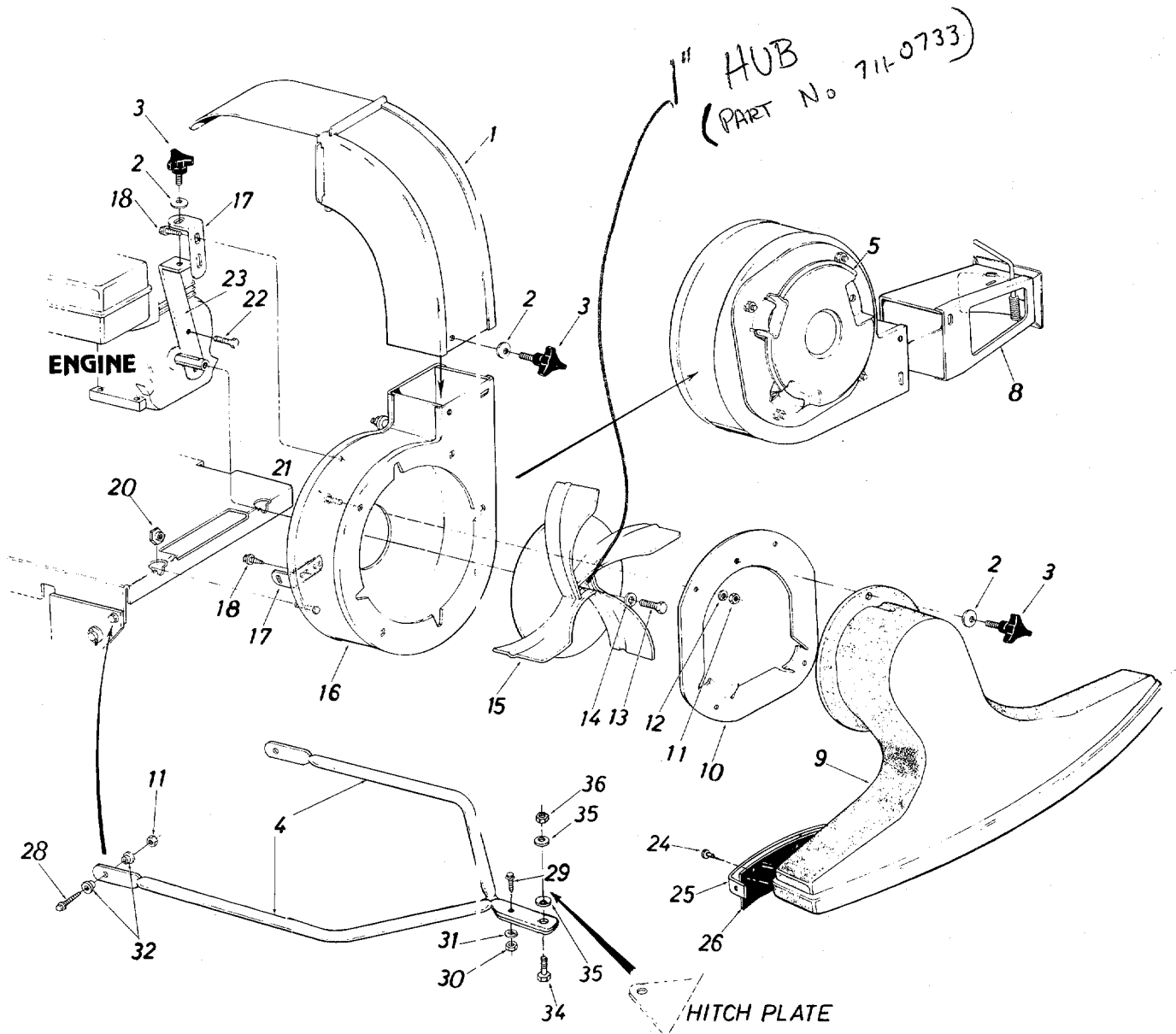

Models 675, 685 and 689

PARTS LIST FOR MODELS 675, 685, 689, 240677 and 240687 POWER VACUUMS

REF. NO.	PART NO.	COLOR CODE	DESCRIPTION	New Part
1	14532--638		Air Duct Assembly	
2	736-0242		Belleville Wash. .34'' I.D. x .87'' O.D.	
3	720-0170		3-Arm Thumb Scr. 5/16-18 x .75'' Lg.	
4	749-0501		Tow Bar Half††	
5	731-0608		Impeller Guard	
8	14479		Directional Discharge Ass'y.	
9	14562B		Nozzle Ass'y. (Black)	
	731-1123		Nozzle Ass'y. (Beige)	
10	14563		Nozzle Plate Ass'y.	
11	712-0267		Hex Nut 5/16-18 Thd.*	
12	736-0119		L-Wash. 5/16'' I.D.	
13	710-0191		Hex Bolt 3/8-24 x 1.25'' Lg.*	
14	736-0217		L-Wash. 3/8'' I.D. H.D.	
15	14536---638		Air Vane Plate Ass'y. (675 and 240677)	
	14557---638		Air Vane Plate Ass'y. w/pulley (685, 698 and 240687)	
16	14496A-638		Blower Housing Complete	N
17	14541		Right Angle Bracket	
18	710-0600		Hex Self-Tap Scr. 5/16-18 x .50'' Lg.	
20	711-0758		Hex Shoulder Nut .50 I.D.	
21	710-0260		Carriage Bolt 5/16-28 x .62'' Lg.*	
22	710-0627		Hex Locking Bolt 5/16-24 x .75'' Lg.	
23	14539		Housing - Engine Brace Ass'y.	
24	728-0173		Pop Rivet (5-Required)	
25	14569		Wiper Retaining Strip	
26	735-0214		Nozzle Wiper	
28	710-0602		Hex Bolt 5/16-18 x 1.00'' Lg.*††	
29	710-0255		Truss Mach. Scr. 1/4-20 x .75'' Lg.*††	
30	712-0287		Hex Nut 1/4-20 Thd.*††	
31	736-0329		L-Wash. 1/4'' I.D.*††	
32	748-0234		Shoulder Spacer††	
34	738-0143		Shld. Bolt .496 Dia.††	
35	736-0219		Belleville Wash. .39 I.D. x 1.12 O.D.††	
36	712-0181		Hex Jam L-Nut 3/8-26 Thd.††	

††Optional Parts

*For faster service obtain standard nuts, bolts and washers locally. If these items cannot be obtained locally, order by part number and size as shown on part list.

COLOR CODE: Specify color code if color or finish is important when ordering parts (i.e., 638 for Red finish).

➔ NOTE

This instruction manual covers various models and all specifications shown do not necessarily apply to your model. Specifications subject to change without notice or obligation.

NOTE: The engine is not under warranty by the vacuum manufacturer. . . If repairs or service is needed on the engine, please contact your nearest authorized engine service outlet. Check the "Yellow Pages" of your telephone book under "Engine—Gasoline."



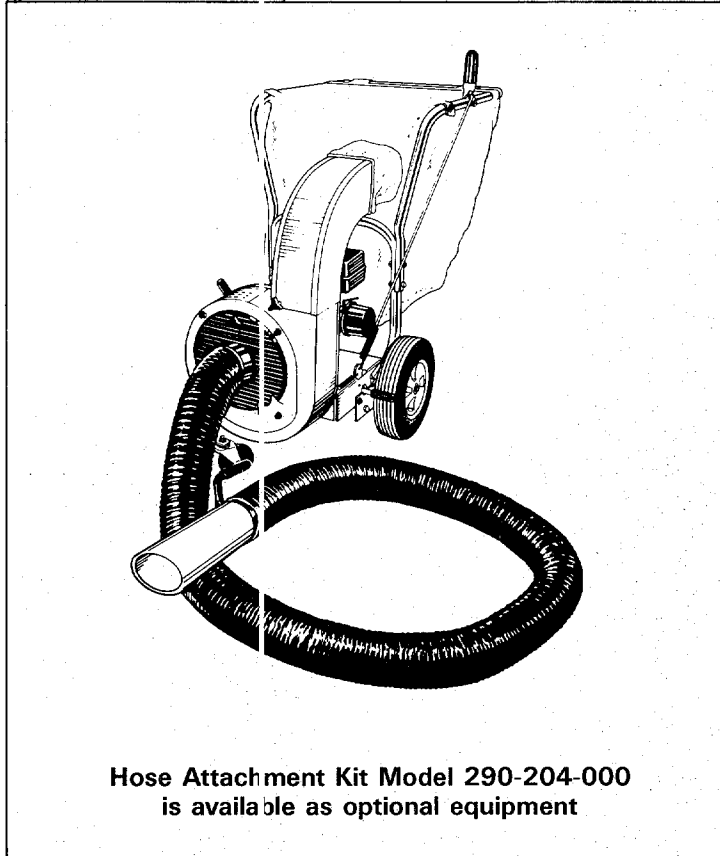

REPLACEMENT PARTS • P.O. BOX 360900 • CLEVELAND, OHIO 44136

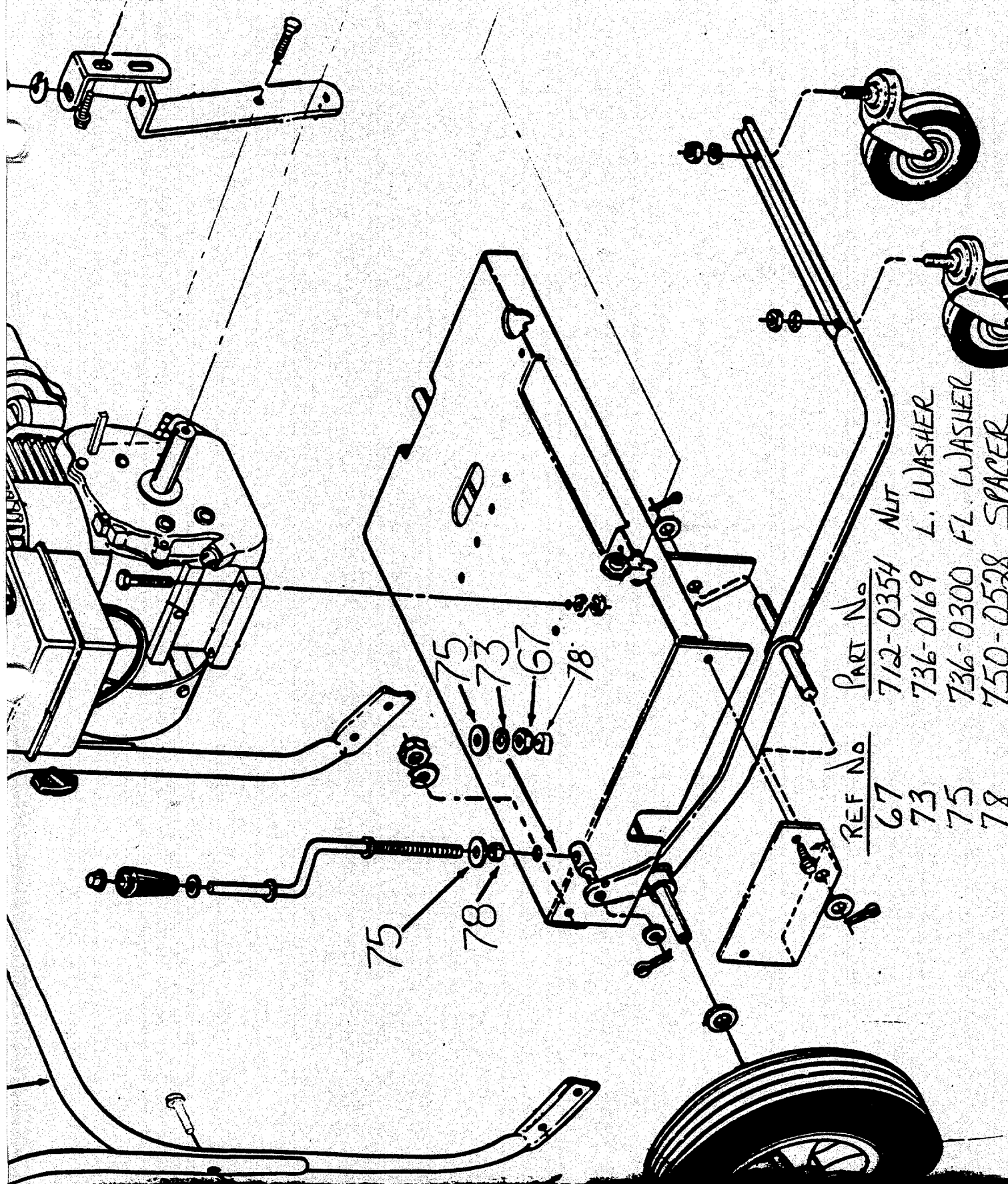

REF No	PART No	DESCRIPTION
67	712-0354	NUT
73	736-0169	L. WASHER
75	736-0300	FL. WASHER
78	750-0538	SPACER



Free Manuals Download Website

<http://myh66.com>

<http://usermanuals.us>

<http://www.somanuals.com>

<http://www.4manuals.cc>

<http://www.manual-lib.com>

<http://www.404manual.com>

<http://www.luxmanual.com>

<http://aubethermostatmanual.com>

Golf course search by state

<http://golfingnear.com>

Email search by domain

<http://emailbydomain.com>

Auto manuals search

<http://auto.somanuals.com>

TV manuals search

<http://tv.somanuals.com>