

# OPERATION AND PARTS MANUAL



*Mikasa* **SERIES**  
**MODEL MRH800DS2**  
**VIBRATORY ROLLER**  
**(YANMAR L100V1AJ1R1AAMK DIESEL ENGINE)**

Revision #1 (4/12/11)

To find the latest revision of this  
publication, visit our website at:  
[www.multiquip.com](http://www.multiquip.com)



**THIS MANUAL MUST ACCOMPANY THE EQUIPMENT AT ALL TIMES.**



**CALIFORNIA — Proposition 65 Warning**

Diesel engine exhaust and some of its constituents are known to the State of California to cause cancer, birth defects and other reproductive harm.



# TABLE OF CONTENTS

## MRH800DS2 Vibratory Roller

Proposition 65 Warning .....	2
Parts Ordering Procedures.....	5
Safety Information .....	6-10
Specifications .....	12-13
Dimensions.....	14
General Information.....	15
Components .....	16-19
Basic Engine.....	20
Inspection .....	22-23
Operation.....	24-27
Maintenance .....	28-32
Troubleshooting .....	33-35
Explanation Of Code In Remarks Column.....	36
Suggested Spare Parts .....	37
Nameplates And Decals .....	38-39
Axle Assy. ....	40-41
Base Assy. ....	42-43
Front Guard Assy.....	44-45
Side Cover Assy.....	46-47
Water Tank Assy. ....	48-49
Hydraulic System Assy. ....	50-53
Hydraulic Oil Tank Assy.....	54-55
Engine Assy.....	56-57
Electric Device Assy.....	58-59
Clutch (Vibration) Assy.....	60-61
Vibrator Assy.....	62-63
Upper Control Arm Assy. ....	64-67
Lower Control Arm Assy. ....	68-69

## Yanmar L100V1AJ1R1AAMK Engine

Cylinder Block Assy.....	70-71
Cylinder Head And Cover Assy .....	72-73
Air Cleaner And Muffler Assy .....	74-75
Crankshaft, Piston, Camshaft Assy.....	76-77
Lub. Oil Pump And Governor Assy.....	78-79
Cooling And Starting Device Assy. ....	80-81
Fuel Injection Pump And Valve Assy.....	82-83
Fuel Tank Assy.....	84-85
Starting Motor And Dynamo Assy.....	86-87
Tool, Label And Gasket Set .....	88-89
Terms and Conditions of Sale — Parts .....	90

### NOTICE

Specifications and part numbers are subject to change without notice.

# PARTS ORDERING PROCEDURES

## Ordering parts has never been easier! Choose from three easy options:

Effective:  
January 1<sup>st</sup>, 2006

www.multiquip.com



### Order via Internet (Dealers Only):

Order parts on-line using Multiquip's SmartEquip website!

- View Parts Diagrams
- Order Parts
- Print Specification Information



If you have an MQ Account, to obtain a Username and Password, E-mail us at: [parts@multiquip.com](mailto:parts@multiquip.com).

To obtain an MQ Account, contact your District Sales Manager for more information.

Goto [www.multiquip.com](http://www.multiquip.com) and click on **Order Parts** to log in and save!

Use the **internet** and qualify for a **5% Discount** on *Standard orders* for all orders which include complete part numbers.\*

Note: Discounts Are Subject To Change



### Order via Fax (Dealers Only):

All customers are welcome to order parts via Fax.

**Domestic (US) Customers dial:**  
1-800-6-PARTS-7 (800-672-7877)

**Fax** your order in and qualify for a **2% Discount** on *Standard orders* for all orders which include complete part numbers.\*

Note: Discounts Are Subject To Change



**Order via Phone: Domestic (US) Dealers Call:**  
1-800-427-1244

### Non-Dealer Customers:

Contact your local Multiquip Dealer for parts or call 800-427-1244 for help in locating a dealer near you.



**International Customers** should contact their local Multiquip Representatives for Parts Ordering information.

## When ordering parts, please supply:

- |   |  |
|---|--|
| <input type="checkbox"/> Dealer Account Number                                | <input type="checkbox"/> Specify Preferred Method of Shipment:                         |
| <input type="checkbox"/> Dealer Name and Address                              | <input checked="" type="checkbox"/> UPS/Fed Ex <input checked="" type="checkbox"/> DHL |
| <input type="checkbox"/> Shipping Address (if different than billing address) | <input type="checkbox"/> Priority One <input checked="" type="checkbox"/> Truck        |
| <input type="checkbox"/> Return Fax Number                                    | <input type="checkbox"/> Ground  |
| <input type="checkbox"/> Applicable Model Number                              | <input type="checkbox"/> Next Day  |
| <input type="checkbox"/> Quantity, Part Number and Description of Each Part   | <input type="checkbox"/> Second/Third Day  |

### NOTICE

All orders are treated as *Standard Orders* and will ship the same day if received prior to 3PM PST.

WE ACCEPT ALL MAJOR CREDIT CARDS!



# SAFETY INFORMATION

Do not operate or service the equipment before reading the entire manual. Safety precautions should be followed at all times when operating this equipment. Failure to read and understand the safety messages and operating instructions could result in injury to yourself and others.



## SAFETY MESSAGES

The four safety messages shown below will inform you about potential hazards that could injure you or others. The safety messages specifically address the level of exposure to the operator and are preceded by one of four words: **DANGER**, **WARNING**, **CAUTION** or **NOTICE**.

## SAFETY SYMBOLS

**DANGER**

Indicates a hazardous situation which, if not avoided, **WILL** result in **DEATH** or **SERIOUS INJURY**.

**WARNING**

Indicates a hazardous situation which, if not avoided, **COULD** result in **DEATH** or **SERIOUS INJURY**.









**CAUTION**

Indicates a hazardous situation which, if not avoided, **COULD** result in **MINOR** or **MODERATE INJURY**.

**NOTICE**

Addresses practices not related to personal injury.

The following table shows the potential hazards associated with the operation of this equipment.

Symbol	Safety Hazard
	Lethal exhaust gas hazards
	Explosive fuel hazards
	Burn hazards
	Respiratory hazards
	Rotating parts hazards
	Pressurized fluid hazards
	Electric shock hazards
	Runover hazards

# SAFETY INFORMATION

## GENERAL SAFETY

### CAUTION

- **NEVER** operate this equipment without proper protective clothing, shatterproof glasses, respiratory protection, hearing protection, steel-toed boots and other protective devices required by the job or city and state regulations.



- **NEVER** operate this equipment when not feeling well due to fatigue, illness or when under medication.



- **NEVER** operate this equipment under the influence of drugs or alcohol.



- **ALWAYS** check the equipment for loosened threads or bolts before starting.
- **DO NOT** use the equipment for any purpose other than its intended purposes or applications.
- **ALWAYS** clear the work area of any debris, tools, etc. that would constitute a hazard while the equipment is in operation.

### NOTICE

- This equipment should only be operated by trained and qualified personnel 18 years of age and older.
- Whenever necessary, replace nameplate, operation and safety decals when they become difficult read.
- Manufacturer does not assume responsibility for any accident due to equipment modifications. Unauthorized equipment modification will void all warranties.
- **NEVER** use accessories or attachments that are not recommended by Multiquip for this equipment. Damage to the equipment and/or injury to user may result.
- **ALWAYS** know the location of the nearest **fire extinguisher**.
- **ALWAYS** know the location of the nearest **first aid kit**.
- **ALWAYS** know the location of the nearest phone or **keep a phone on the job site**. Also, know the phone numbers of the nearest **ambulance, doctor and fire department**. This information will be invaluable in the case of an emergency.



# SAFETY INFORMATION

## ROLLER SAFETY

### DANGER

- **NEVER** operate the equipment in an explosive atmosphere or near combustible materials. An explosion or fire could result causing severe **bodily harm or even death.**



### WARNING

- **NEVER** disconnect any **emergency or safety devices.** These devices are intended for operator safety. Disconnection of these devices can cause severe injury, bodily harm or even death. Disconnection of any of these devices will void all warranties.

### CAUTION

- **NEVER** lubricate components or attempt service on a running machine.
- Never leave the roller unattended with the engine running. Turn off engine.
- Use chock blocks when parking roller on a grade.
- Use extreme care when operating near obstructions, on slippery surfaces, grades, and slide slopes.
- When reversing, particularly on the edges and banks of ditches, as well as in front of obstacles, the operator must stay in a standing position at a safe distance from the machine.
- When operating near any house/building or pipelines, always check the effect of machine vibration. Stop work if necessary.
- **DO NOT** operate the roller with the covers open.
- **ALWAYS** keep the machine away from other personnel and obstacles. Always keep immediate area free of bystanders.

### NOTICE

- **ALWAYS** keep the machine in proper running condition.
- Fix damage to machine and replace any broken parts immediately.

- **DO NOT** use worn-out hoses or couplings. Inspect daily.
- **ALWAYS** store equipment properly when it is not being used. Equipment should be stored in a clean, dry location out of the reach of children and unauthorized personnel.

## ENGINE SAFETY

### DANGER

- The engine fuel exhaust gases contain poisonous carbon monoxide. This gas is colorless and odorless, and can cause death if inhaled.
- The engine of this equipment requires an adequate free flow of cooling air. **NEVER** operate this equipment in any enclosed or narrow area where free flow of the air is restricted. If the air flow is restricted it will cause injury to people and property and serious damage to the equipment or engine.



### WARNING

- **DO NOT** place hands or fingers inside engine compartment when engine is running.
- **NEVER** operate the engine with heat shields or guards removed.
- Keep fingers, hands hair and clothing away from all moving parts to prevent injury.
- **DO NOT** remove the engine oil drain plug while the engine is hot. Hot oil will gush out of the oil tank and severely scald any persons in the general area of the roller.



### CAUTION

- **NEVER** touch the hot exhaust manifold, muffler or cylinder. Allow these parts to cool before servicing equipment.
- Always turn the engine off before performing maintenance.





# SAFETY INFORMATION

## NOTICE

- **NEVER** run engine without an air filter or with a dirty air filter. Severe engine damage may occur. Service air filter frequently to prevent engine malfunction.
- **NEVER** tamper with the factory settings of the engine or engine governor. Damage to the engine or equipment can result if operating in speed ranges above the maximum allowable. 
- **NEVER** tip the engine to extreme angles during lifting as it may cause oil to gravitate into the cylinder head, making the engine start difficult.

## FUEL SAFETY

### DANGER

- **DO NOT** add fuel to equipment if it is placed inside truck bed with plastic liner. Possibility exists of explosion or fire due to static electricity.

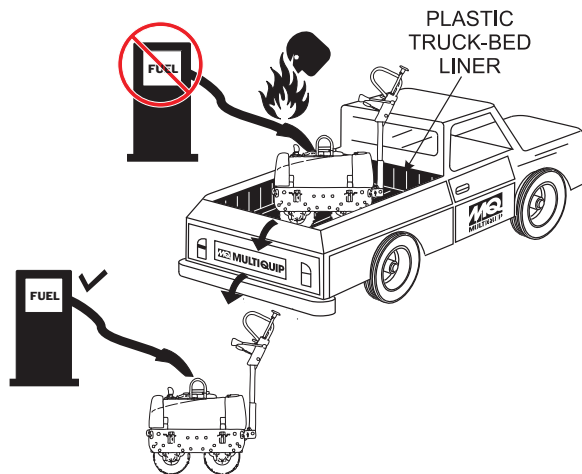

- **DO NOT** start the engine near spilled fuel or combustible fluids. Diesel fuel is extremely flammable and its vapors can cause an explosion if ignited.
- **ALWAYS** refuel in a well-ventilated area, away from sparks and open flames.
- **ALWAYS** use extreme caution when working with **flammable** liquids.
- **DO NOT** fill the fuel tank while the engine is running

or hot.



- **DO NOT** overfill tank, since spilled fuel could ignite if it comes into contact with hot engine parts or sparks from the ignition system.
- Store fuel in appropriate containers, in well-ventilated areas and away from sparks and flames.
- **NEVER** use fuel as a cleaning agent.
- **DO NOT** smoke around or near the equipment. Fire or explosion could result from fuel vapors or if fuel is spilled on a hot engine. 

## BATTERY SAFETY (ELECTRIC START ONLY)

### DANGER

- **DO NOT** drop the battery. There is a possibility that the battery will explode.
- **DO NOT** expose the battery to open flames, sparks, cigarettes, etc. The battery contains combustible gases and liquids. If these gases and liquids come into contact with a flame or spark, an explosion could occur. 

### WARNING

- **ALWAYS** wear safety glasses when handling the battery to avoid eye irritation. The battery contains acids that can cause injury to the eyes and skin. 
- Use well-insulated gloves when picking up the battery.
- **ALWAYS** keep the battery charged. If the battery is not charged, combustible gas will build up.
- **DO NOT** charge battery if frozen. Battery can explode. When frozen, warm the battery to at least 61°F (16°C).
- **ALWAYS** recharge the battery in a well-ventilated environment to avoid the risk of a dangerous concentration of combustible gases.
- If the battery liquid (dilute sulfuric acid) comes into contact with **clothing or skin**, 

# SAFETY INFORMATION

rinse skin or clothing immediately with plenty of water.

- If the battery liquid (dilute sulfuric acid) comes into contact with **eyes**, rinse eyes immediately with plenty of water and contact the nearest doctor or hospital to seek medical attention.

## ⚠ CAUTION

- **ALWAYS** disconnect the **NEGATIVE** battery terminal before performing service on the equipment.
- **ALWAYS** keep battery cables in good working condition. Repair or replace all worn cables.

## TRANSPORTING SAFETY

## ⚠ CAUTION

- **NEVER** allow any person or animal to stand underneath the equipment while lifting.

## NOTICE

- Before lifting, make sure that the equipment parts are not damaged and screws are not loose or missing.
- Use lifting equipment capable of lifting the weight of the roller.
- Always make sure crane or lifting device has been properly secured to the lifting bail (hook) of the equipment.
- **ALWAYS** shutdown engine before transporting.
- **NEVER** lift the equipment while the engine is running.
- Tighten fuel tank cap securely and close fuel cock to prevent fuel from spilling.
- Use adequate lifting cable (wire or rope) of sufficient strength.
- Use one point suspension hook and lift straight upwards with sufficient bearing capacity to prevent machine from tilting or slipping.
- **DO NOT** lift machine to unnecessary heights.
- **ALWAYS** make sure that roller is secured correctly when

transporting on a trailer. Make sure all supports attaching the roller to the trailer are tight.

## ENVIRONMENTAL SAFETY

### NOTICE

- Dispose of hazardous waste properly. Examples of potentially hazardous waste are used motor oil, fuel and fuel filters. 
- **DO NOT** use food or plastic containers to dispose of hazardous waste.
- **DO NOT** pour waste, oil or fuel directly onto the ground, down a drain or into any water source.



**Table 1. Specifications (Vibratory Roller)**

Dimensions	105 x 27.2 x 41.7 in (2670 x 692 x 1060 mm)
Drum Diameter	16 in. (406 mm)
Drum Width	25.6 in. (650 mm)
Curb Clearance	9.6 in. (243 mm)
Side Overhang	.83 in. (21 mm)
Operating Weight (with water)	1562 lbs. (710 kg)
Vibration Frequency	3,300 vpm
Centrifugal Force	23.5/2,400 kn/kgf
Drive System	Hydraulic Motor
Vibration System	Frame
Vibration Method	Belt Drive
Vibrator Shaft	Twin
Gradeability	35 degrees
Working Speed	0 - 3 mph (0 - 4.8 kph)
Fuel Tank Capacity	1.88 gallons (7.1 liters)
Lubricating Oil	6.6 gallons (25 liters)
Water Tank Capacity	10.57 gallons (40 liters)
Engine Model	YANMAR Model L100V1AJ1R1AAMK
Starting System	Electric/Recoil Start

**Table 2. Specifications (Engine)**

Engine Model	YANMAR L100V1AJ1R1AAMK
Engine Type	Air-cooled Diesel
Cylinder Bore X Stroke	3.4 x 2.95 in (86 x 75 mm)
Displacement	14.7 fl oz (435 cc)
Maximum Output	8.7 HP
Fuel Tank Capacity	5.6 quarts (5.4 liters)
Oil Capacity	1.7 quarts (1.6 liters)
Dry Net Weight	117.9 lbs. (54 kg)
Dimensions (L x W x H)	16.22 x 18.54 x 19.45 in (412 x 471 x 494 mm)

# DIMENSIONS

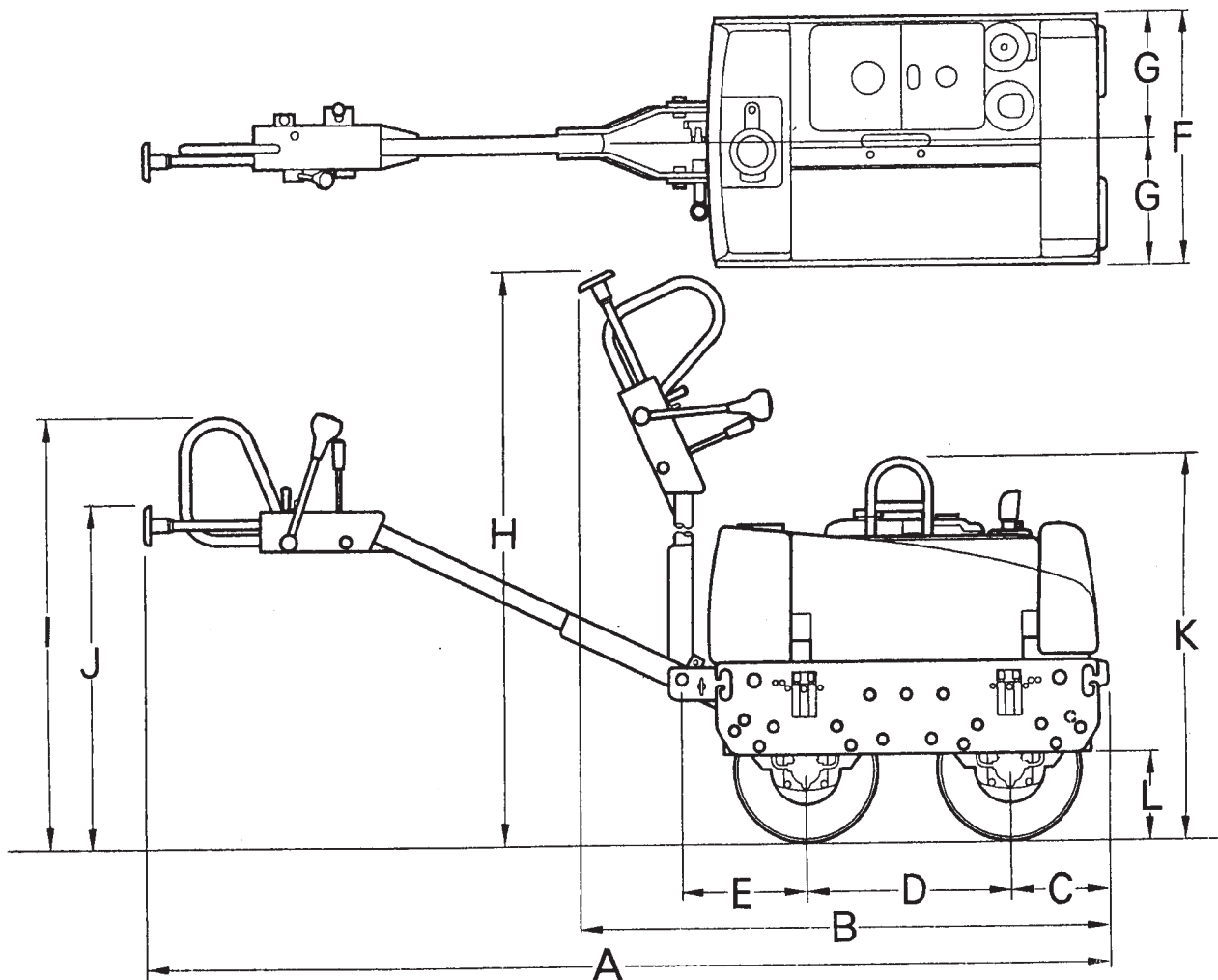

Figure 1. MRH800DS2 Dimensions

Table 3. Dimensions			
LENGTH	A	105 in.	2670 mm.
	B	57 in.	1445 mm.
	C	10 in.	255 mm.
	D	22.8 in.	580 mm.
	E	13.8 in.	350 mm.
WIDTH	F	27.2 in.	692 mm.
	G	13.6 in.	346 mm.
HEIGHT	H	78.3 in.	1990 mm.
	I	46.5 in.	1180 mm.
	J	37.4 in.	950 mm.
	K	41.7 in.	1060 mm.
	L	9.6 in.	245 mm.

The Mikasa Model MRH800DS2 is a powerful compacting tool capable of applying tremendous force in consecutive impacts to a soil surface. Its applications include soil compacting for backfilling for gas pipelines, water pipelines and cable installation work.

The impact force of the MRH800DS2 levels and uniformly compacts voids between soil particles to increase dry density.

Features include:

- Hydraulic transmission to allow speed change without gear shifting.
- Deadman device which when pressed or hit will cause the travel lever to return to neutral position bringing the machine to a stop.
- A horn to warn of machine's approach.
- Non-corrosive water tank for the sprinkler system with a capacity of more than 10 gallons.
- Lifting hook to transport machine.
- Front bumper and working light.
- Narrow profile with less than one inch wall clearance. Narrower width allows access to tighter areas. No exposed hydraulic hoses.
- Oil bath lubricated bearings and external vibration for less servicing and more dependability.
- Front and rear drum scrapers.
- Drum sprinkler system controls located near the operator.
- Easy access to hydraulic components and hydraulic filter.

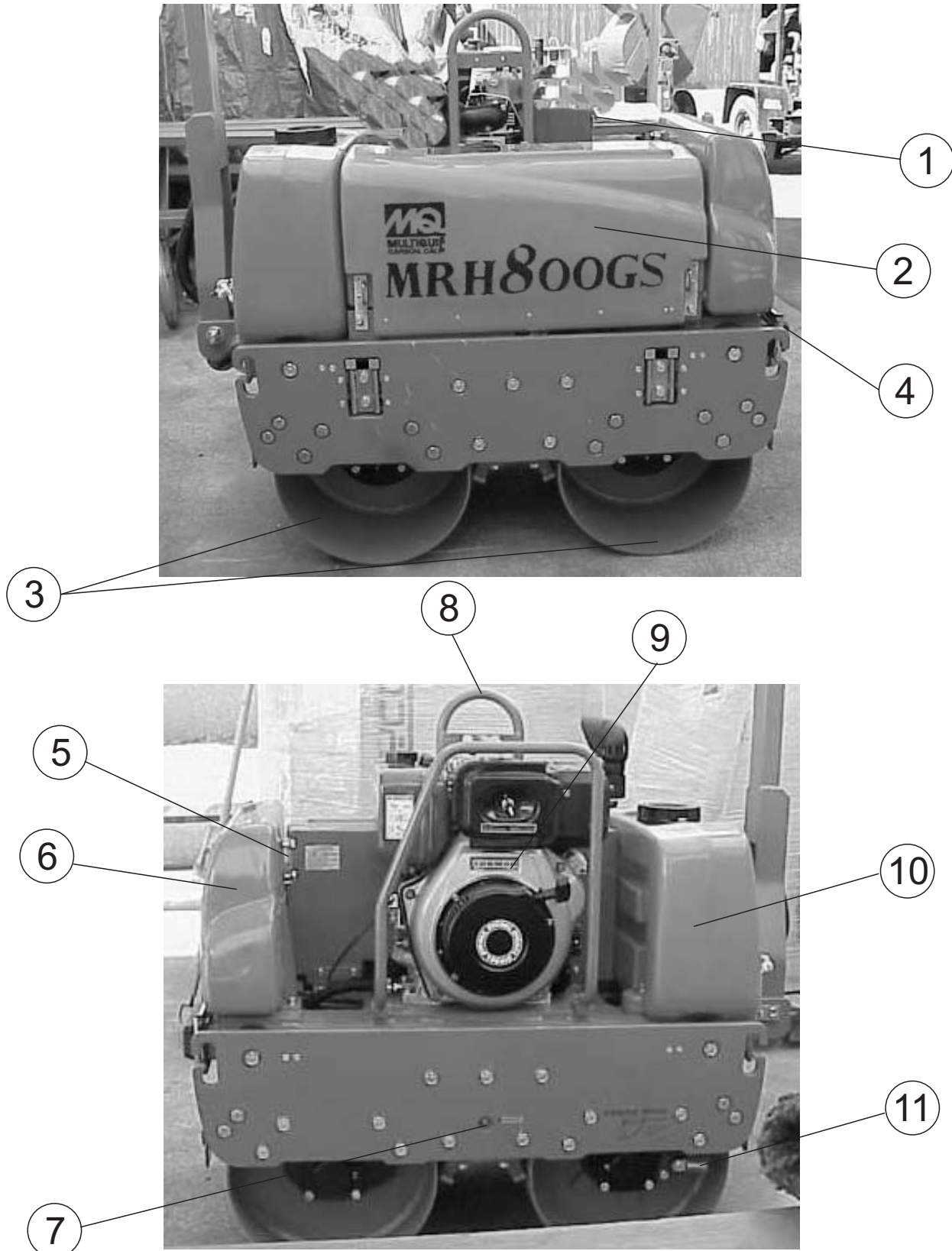

Figure 2. MRH800DS2 Components



Figure 2 illustrates the location of the major components for the MRH800DS2 Vibration Roller. The function of each component is described below:

1. **Fuel Tank/Cap** — Fill with diesel fuel. Fuel tank holds approximately 2 gallons (7.5 liters). DO NOT top off fuel. Wipe up any spilled fuel immediately.
2. **Center Cover** — When opened and supported by strut, provides access to oil pump and filter, battery, V-belt, and clutch box.
3. **Vibration Rollers** — 25-inch wide steel drums that provide compaction force in the compaction and patching of asphalt type surfaces.
4. **Front Headlights** — Activate using switch on control handle. Use to illuminate ground during nighttime or low-light operating conditions.
5. **Hydraulic Oil Gauge** — Indicates the hydraulic oil level.
6. **Oil Tank** — Fill with proper grade of hydraulic oil.
7. **Vibrator Oil Level Plug** — Remove to check vibrator oil level.
8. **Lifting Hook** — Used to lift the machine with crane or other lifting device.
9. **Engine** — This machine uses the Yanmar L100V1AJ1R1AAMK engine. Refer to the engine Owner's Manual for more information.
10. **Water Tank** — Holds 10.57 gallons (40 liters) for the sprinkler system.
11. **Parking Brake** — Makes sure machine will not accidentally move when parked or not in use.

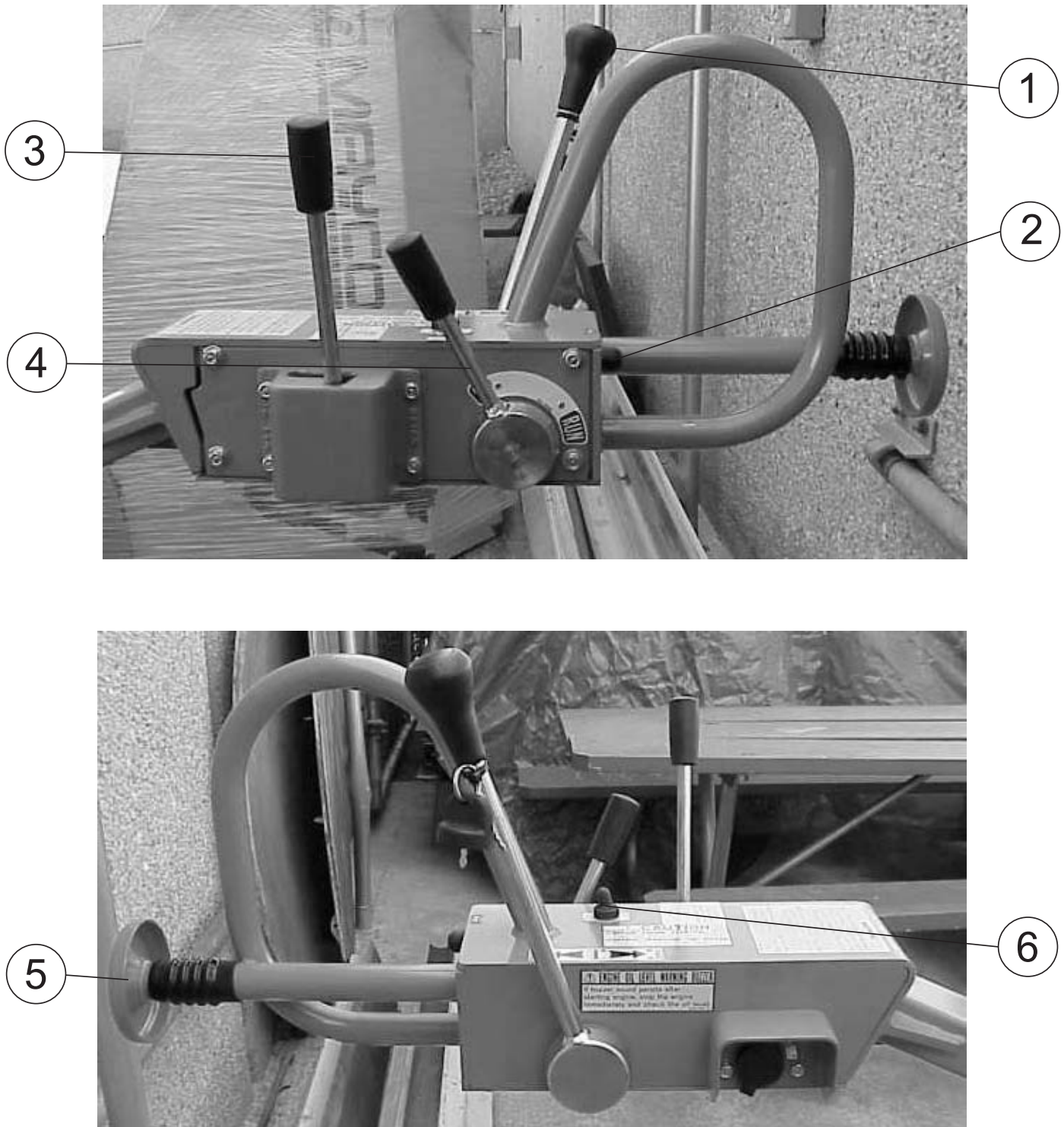

Figure 3. Handle Bar/Lever Components

## HANDLE BAR/LEVER COMPONENTS

Figure 3 illustrates the location of the major lever components on the handle bar of the machine. Each component is described below:

1. **Travel Lever** — Controls the direction of travel of the machine (forward and reverse).
2. **Horn Button** — When pressed, gives a warning sound of the machine approaching.
3. **Vibration Lever** — Turns vibration on and off.
4. **Throttle Lever** — Controls the start up of the machine.
5. **Dead-Man Device** — When pressed or hit while traveling in reverse, causes the travel lever to return to neutral position to stop the machine.
6. **Light ON/OFF Switch** — Turns headlight on and off.
7. **Starter Switch** — Engine starts when key is turned to the RUN position.

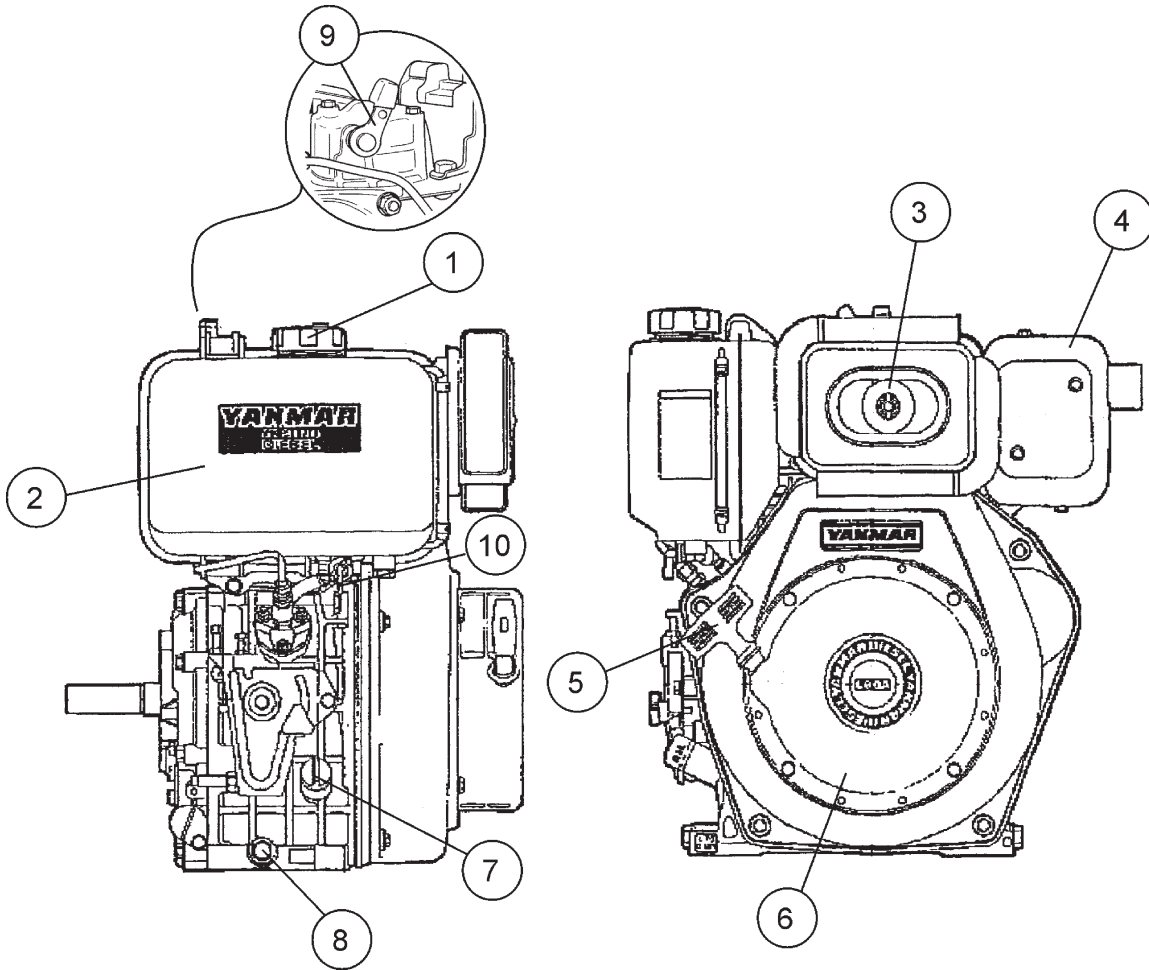

Figure 4. Yanmar Engine Components

## ENGINE COMPONENTS

Figure 4 illustrates the location of the major engine components. Each component is described below:

1. **Fuel Filler Cap** — Remove this cap to add unleaded gasoline to the fuel tank. Make sure cap is tightened securely. DO NOT over fill.
2. **Fuel Tank** — Diesel engine holds 5.7 quarts of diesel fuel.
3. **Air Cleaner** — Prevents dirt and other debris from entering the fuel system. Remove wing-nut on top of air filter canister to gain access to filter element.
4. **Muffler** — Used to reduce noise and emissions.
5. **Recoil Starter (pull rope)** — Type of engine starting method. Alternate type would be electric start (ignition key).
6. **Recoil Starter** — Housing for pull rope and starter.
7. **Oil Filler Cap/Dipstick** — Remove this cap to add oil to the oil tank. Use dipstick to check oil level.
8. **Oil Drain Plug** — Unscrew plug to drain oil from engine crankcase. Dispose of oil in a safe manner.
9. **Decompression Lever** — Press down before starting engine. To prevent damage to the engine, DO NOT use for any other purpose.
10. **Fuel Cock** — Controls the flow of diesel fuel to the engine. Must be in the ON position when starting and running the engine.



## BEFORE STARTING

1. Read safety information at the beginning of manual.
2. Remove dirt and dust, particularly in the engine cooling air inlet, carburetor and air cleaner.
3. Check the air filter for dirt and dust. If air filter is dirty, replace air filter with a new one.
4. Check carburetor for external dirt and dust. Clean with dry compressed air.
5. Check fastening nuts and bolts for tightness.
6. Understand the geographical features and regulations of the job site.

## ENGINE OIL CHECK

1. To check the engine oil level, place the machine on secure level ground with the engine stopped.
2. Remove the filler dipstick from the engine oil filler hole (Figure 5) and wipe clean.

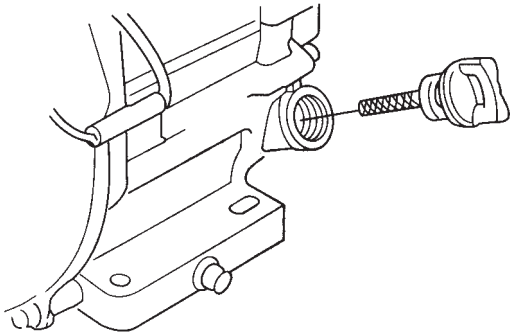

**Figure 5. Engine Oil Level**

3. Insert and remove the dipstick without screwing it into the filler neck. Check the oil level shown on the dipstick.
4. If the oil level is low, fill to the edge of the oil filler hole with the recommended oil type (Table 4). Maximum oil capacity is 1.16 quarts (1.1 liters).

Season	Temperature	Oil Type
Summer	25°C or Higher	SAE 10W-30
Spring/Fall	25°C~10°C	SAE 10W-30/20
Winter	0°C or Lower	SAE 10W-10

## CHECKING THE HYDRAULIC SYSTEM

1. Check the oil tank level gauge (Figure 6). Oil level should be at the middle indication of the gauge or higher. Fill as required.



LEVELS SHOULD BE MIDDLE OF GAUGE OR HIGHER

**Figure 6. Hydraulic System Oil Level Gauge**

2. Check the surroundings of the oil tank, hydraulic pump and motor for oil leakage.

## CHECKING THE V-BELT

**! DANGER**



**ALWAYS** keep hands and fingers away from pinch points. **DO NOT** allow anyone to reach in on dangerous sections of the machine to avoid any accidents.

1. Remove the 2 bolts, one on each side of the center cover, with a #13 socket wrench. Open the center cover of the machine and support it with the strut by inserting its end to the hole in the base (Figure 7).

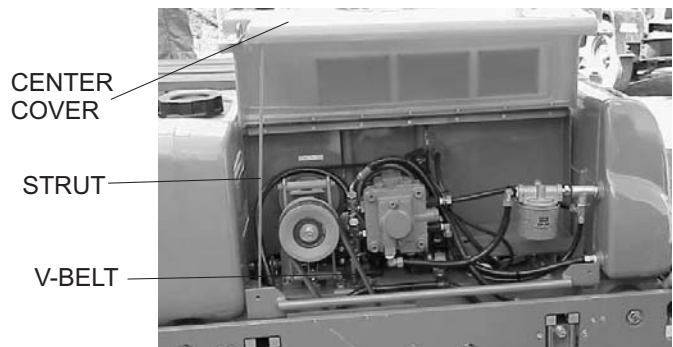

**Figure 7. Checking V-Belt Tension**

2. Check V-belt for proper tension. Insufficient tension causes weak vibration.



## CHECKING THE VIBRATOR OIL LEVEL

1. Check vibrator casing for any oil leakage.
2. If any leakage is noticed, remove the level plug on the side of the plate (Figure 8).

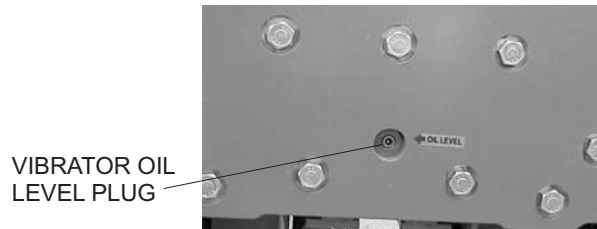

Figure 8. Checking Vibrator Oil Level

3. Check the oil level.

## FUEL CHECK

### DANGER



Motor fuel is highly flammable and can be dangerous if mishandled. **DO NOT** smoke while refueling. **DO NOT** attempt to refuel the pump if the engine is *hot or running*.

1. Remove the fuel cap located on top of the engine fuel tank.
2. Visually inspect to see if the fuel level is low. If fuel is low, replenish with unleaded gasoline using a strainer for filtration. **DO NOT** top-off fuel. Wipe up any spilled fuel immediately!

## CHECKING WATER TANK

Check the water tank to see if filled. Add water if necessary. The water tank has a capacity of approximately 10 gallons (40 liters). See Figure 9.



Figure 9. Checking Water Tank

### CAUTION

Be careful not to confuse the water tank with the oil tank.

## CHECKING LEVERS AND HORN

1. Check travel, vibration, and throttle levers to make sure they are functioning properly (Figure 3).
2. With travel lever placed in reverse, push the deadman device and verify that the travel lever returns to neutral position. The travel lever stays in neutral position once the deadman device is released.
3. Press the horn and verify that it functions properly.

## CHECKING SCRAPERS

1. Check scrapers and make sure that they are not clogged with mud, bent or damaged (Figure 10).

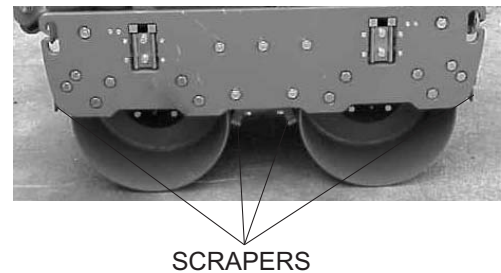

Figure 10. Checking Scrapers

2. Adjust clearance between drums and scrapers as necessary.

## CHECKING BOLTS, NUTS AND SCREWS

1. Check bolts, nuts, and screws on various parts of the machine, including the engine, for proper tightness.

## POSITIONING THE HANDLE BAR

1. Release the handle bar release pin (Figure 11) and position the handle bar to the lowered position before starting operation.



Figure 11. Positioning the Handle Bar

2. When machine is not in use, release the handle bar release pin and position the handle bar to the upright position.

## CAUTION



**DO NOT** attempt to operate the roller until the Safety Information, General Information, and Inspection sections of this manual have been **read and thoroughly understood**.

## STARTING THE ENGINE

The engine can be started by motor (electric) or manually (recoil). Refer to Figure 2 and Figure 3 for the location of controls and components.

### Electric Start

## CAUTION

When the engine is running, never turn the starter key to the **START** position

1. On the control handle:
  - a. Move the throttle lever to the **RUN** position.
  - b. Move the travel lever to the **NEUTRAL** position.
  - c. Move the vibration lever to the **OFF** position.
2. Open the fuel cock by turning it clockwise to the down position (Figure 12).



FUEL COCK  
(OPEN POSITION)

**Figure 12. Open Fuel Cock**

3. Insert the starter key into the key switch and turn it to the **RUN** position (Figure 13). The buzzer should sound at this time.

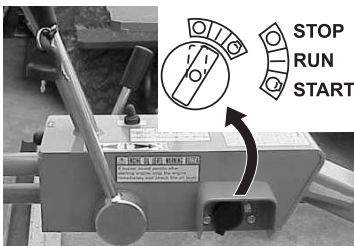

**Figure 13. Starter Key (Run Position)**

4. Turn the starter key further to the right to the **START** position (Figure 14) to start the engine. Buzzer stops sounding when the engine speed increases. With safety switch equipped, motor runs only when the travel lever is in the neutral position.

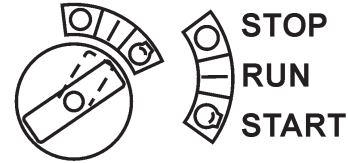

**Figure 14. Starter Key (Start Position)**

5. If the engine fails to start, do not continue to rotate the starter key for more than 5 seconds. Return the key to the **RUN** position and wait 20 to 30 seconds before starting again.
6. After starting the engine, continue to warm up the engine for about 3 to 10 seconds especially in cold weather.
7. If the buzzer does not stop sounding after the engine has started, shutdown engine immediately and check engine oil level. The buzzer functions as engine oil level warning also.

## RECOIL START

1. Move the throttle lever to the **RUN** position.
2. Open the fuel cock by turning it clockwise to the down position (Figure 12).
3. Pull the starting handle slowly until you feel some resistance (Figure 15). Return handle to original position.



PULL HANDLE  
TO START

**Figure 15. Engine Start Handle**



4. Push down the decompression lever (Figure 16).

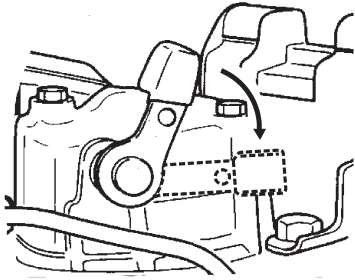

**Figure 16. Decompression lever**

5. Pull the starting handle hard and fast to start engine (Figure 15).
6. If the engine does not start, repeat steps 3 through 5.

## NOTICE

When starting with a motor starter, a decompressor is not normally required. However, when ambient temperature or battery charger level is low, use of a decompressor will help make the start-up easier.

## TRAVELING

1. Before starting to travel, make sure to release parking brake located on the left side of the rear roller. If the parking brake lever is tight, moving the roller back and forth will make it easier (Figure 17).



**PARKING BRAKE  
(RELEASED  
POSITION)**

**Figure 17. Parking Brake**

2. With the throttle lever in the **RUN** position, increase the engine rotation.
3. Push the travel lever forward slightly. This will cause the roller to travel forward at slow speed.
4. To increase the travel speed, push the travel lever further.
5. Travel speed can be varied between 0 and 3 km/h (both forward and reverse).

6. Push the travel lever backward to go in the reverse direction.

## CAUTION

Do not reduce speed during work. When shifting travel lever from forward to reverse, be sure to stop the lever at the neutral position first before moving the lever to the opposite direction. Do not shift the lever from forward to reverse (or reverse to forward) in one motion.

## CAUTION

After test travel, shut down engine and check for any problems including oil leakage. If any trouble is found, correct the problem before attempting to operate the roller again.

## VIBRATING

1. Shift the vibration lever away from its off position. The vibration lever will automatically spring forward and the roller will start vibrating (Figure 18).



**VIBRATION LEVER  
(OFF POSITION)**

**Figure 18. Vibration Lever (Off Position)**

## CAUTION

Using vibration with clutch slipping causes the clutch to burn. Also, vibration should not be used over completely compacted area, paved road surface, or with stationary roller.

## WATERING

- For watering work, turn the water cocks clockwise, at the rear of the machine, to start sprinkling. (Figure 19).

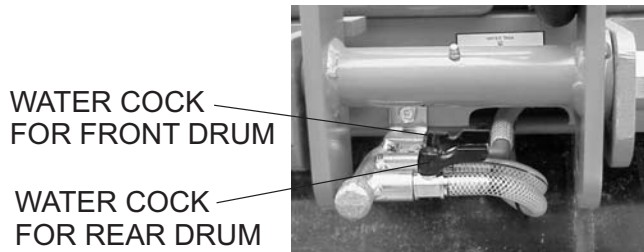

Figure 19. Water Cocks

## SAFETY FEATURES

A horn is provided to warn of approach.

The dead man device prevents accidental traveling in reverse. It automatically makes the travel lever return to neutral position by stopping the machine when an object comes in contact with the dead man device.

## STOPPING

- With travel lever in the neutral position, and the vibration lever in the off position, return the throttle lever to the START position. Allow the machine to cool down for 3 to 5 minutes.
- Push the throttle lever forward to stop the engine. In a motor start, return the key switch to the STOP position as soon as the engine stops.

### CAUTION

Neglecting to return the key switch to the STOP position will cause the battery to discharge making start up impossible the next time.

- After the engine stops, close the fuel cock.
- Lock the parking brake by pulling the brake lever and rotating it 90° clockwise.

### NOTICE

Parking brake system should always be kept clean to avoid mud deposits.

## UNLOADING

- If you need to move the roller by pushing it manually once engine is stopped, loosen bolt of bypass valve on oil pump by one rotation counterclockwise. This will cause the hydraulic brake to disengage and allow the roller to be moved more easily (Figure 20).

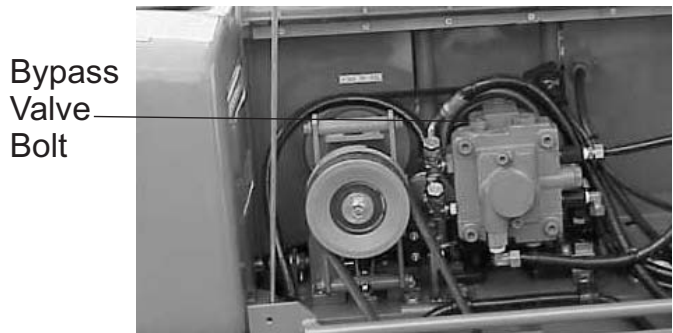

Figure 20. Location of Bypass Valve Bolt

- After moving, tighten the bolt again. Tightening torque is 55 to 70 kgf-cm.

### CAUTION

**NEVER** tow roller with any type of vehicle. Doing so will damage the hydraulic system.

Never perform unloading procedure on a slope. This may cause roller to roll down if parking brake or blocking is deficient.

## LIFTING

- Use a crane or lift to load and unload the machine. A skilled crane operator is required to perform the job.
- When lifting the machine, check for any damaged or loose bolts, lifting hooks, and shock mounts.
- Check any damaged or loose bolts in the guard frame to avoid machine sliding off.
- Make sure that the machine is shut off before machine is lifted.
- Use reliable cable for lifting.
- Always lift the machine vertically and keep the machine away from workers and animals.
- Do not lift the machine higher than the required height.

## TRANSPORTING

1. Always make sure that the machine is shut off while being transported.
2. Check that the fuel cap is properly closed and tightened.
3. When traveling long distances or on rugged terrain, drain the fuel of the machine before transporting.
4. Tie down the machine securely on the transportation so that it will not move or topple over.

 **CAUTION**

Inspection and other services should always be carried out on hard and level ground with the engine shutdown.

## CAUTION

Inspection and other services should always be carried out on hard and level ground with the engine shutdown.

## INSPECTION AND MAINTENANCE SERVICE TABLES

To make sure your vibratory roller is always in good working condition before using, carry out the maintenance inspection procedures.

**Table 5. Machine Inspection**

ITEM	HOURS OF OPERATION
Loose or Missing Screws	Every 8 hours (every day)
Damaged Parts	Every 8 hours (every day)
Function of Controlling System Part	Every 8 hours (every day)
Hydraulic System Leak	Every 100 hours
Vibrator Oil Check	Every 100 hours
Vibrator Oil Replacement	Every 300 hours
Hydraulic Oil Check	Every 100 hours
Hydraulic Oil Replacement	First after 200 hours, then every 1,000 hours
V-belt (clutch) Check	Every 200 hours
Battery Check	Every 100 hours

## NOTICE

These inspection intervals are for operation under normal conditions. Adjust your inspection intervals based on the number of hours the roller is in use, and your particular working conditions.

## NOTICE

Fuel piping and connections should be replaced every 2 years.

**Table 6. Engine Check**

ITEM	HOURS OF OPERATION
Oil or Fuel Leak	Every 8 hours (every day)
Tightness of Fastening Threads	Every 8 hours (every day)
Engine Oil Check and Replenishment	Every 8 hours (every day) (Replenish to specified maximum level)
Engine Oil Replacement	After first 25 hours then every 50 to 100 hours
Air Filter Cleaning	Every 100 hours

## DAILY SERVICE

1. Check for leakage of fuel or oil.
2. Check for loose screws including tightness. See Table 7 below (tightening torque), for retightening:

**Table 7. Tightening Torque (in. kg/cm) Diameter**

Material	6mm	8mm	10mm	12mm	14mm	16mm	18mm	20mm
4T	70	150	300	500	750	1,100	1,400	2,000
6-8T	100	250	500	800	1,300	2,000	2,700	3,800
11T	150	400	800	1,200	2,000	2,900	4,200	5,600
*	100	300~ 350	650~ 700					

3. Remove soil and clean the bottom of roller.
4. Check hydraulic pump, piping and hose for any leakage.
5. A loosened hydraulic hose can be a cause for leakage. Check hydraulic hose connections with wrench applied for tightness.
6. Check engine oil.

## ENGINE OIL REPLACEMENT:

1. Replace engine oil in the first 25 hours of operation and every 50 to 100 hours afterwards.
2. Oil may be drained more easily when it is warm after operation (For more details, see separate engine Owner's Manual).

## AIR FILTER

1. The air filter element should be cleaned because a clogged air cleaner can cause poor engine starting, lack of power and shorten engine life substantially.
2. To clean or replace air filter loosen the wing nut on the air filter housing (Figure 21) remove the cover and take out air filter cartridge. If only cleaning of the air filter is desired blow through the air filter cartridge from the inside, moving a jet of dry compressed air up and down until all dust is removed.

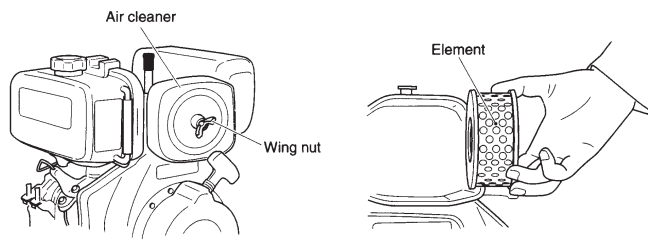

**Figure 21. Engine Air Filter and Element**

## VIBRATION CLUTCH ADJUSTMENT

1. Move vibration lever to the OFF position.
2. Loosen the front and rear nuts at the end of vibration clutch cable (Figure 22).

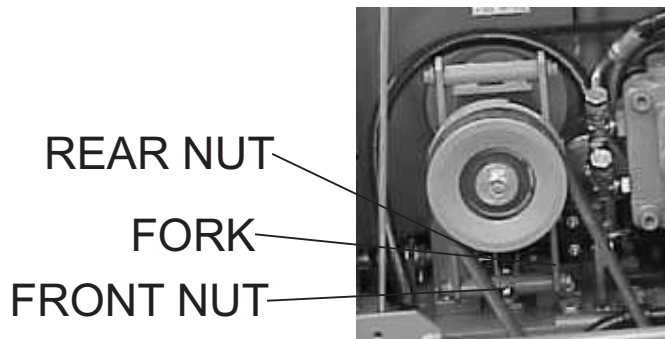

**Figure 22. Vibration Clutch Adjustment**

3. Turn in the nut on the front side again and at the position that release fork starts to move, turn in the nut by one or two threads. Lock it a this position together with the rear nut.

### CAUTION

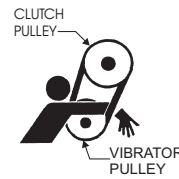

NEVER attempt to check the V-belt with the engine running. Severe injury can occur if your hand gets caught between the V-belt and the clutch. Always use safety gloves.

### CAUTION

Excessive turning of front nut may cause the sliding engagement of clutch to take place or no vibration takes place even when vibration lever is engaged.

On the other hand, insufficient turn may cause sliding engagement of clutch even when the vibration lever is placed in the OFF position or for vibration to remain engaged.

## HYDRAULIC SYSTEM INSPECTION AND SERVICE

1. Check motor and pump for any damage.
2. Check hoses and pipes for proper tightness and make sure there are no leaks.
3. Check nylon tubes for hydraulic oil intake and drain. Retighten brass nut if loose and if a leak is detected. If leak continues after retightening, replace nylon tube, nut and sleeve.
4. Check oil tank for proper oil level using the hydraulic system oil level gauge (See Figure 6). Make sure hydraulic oil has not whitened or emulsified. Whitish color means aeration in pump. Retighten pipe and correct level of oil. Emulsification means water in the hydraulic oil. Replace the oil.

## ROLLER INSPECTION AND ADJUSTMENT

1. Refer to Table 8 for oil and grease requirements.
2. Check oil tank level daily.
3. Check the machine for oil leak and proper function of lever, cables, and links daily.



## MACHINE MAINTENANCE

1. At the end of each day's operation, wash down dust and dirt off the machine. Clean area around drums and scrapers making sure all mud is removed.
2. Drain water tank completely.
3. Cover the machine to prevent dust and store in dry place away from sun exposure.

## LONG TERM STORAGE

1. Conduct thorough lubrication and oil change.
2. Disconnect battery terminals and dismount battery from machine. Store battery.
3. If there is a possibility that ambient temperature will drop below freezing point, add antifreeze agent to coolant.
4. Cover the inlet and outlet of air cleaner and muffler securely.
5. Store machine indoors. Do not leave outdoors.
6. Refer to Table 8 for lubrication necessary for the machine.

## BATTERY MAINTENANCE

### NOTICE

Read and understand the battery safety information in the front of this manual before performing maintenance on the battery.

1. Use a flashlight to check battery electrolyte level. Always check that the engine is stopped.
2. If a battery has not been used for some time, reduce the charge level initially to protect each plate inside the battery.
3. Check the battery terminals periodically to ensure that they are in good condition.
4. Use wire brush or sand paper to clean the battery terminals.
5. Check battery for cracks or any other damage. If white pattern appears inside the battery or paste has accumulated at the bottom, replace the battery.
6. Measure the specific gravity of electrolyte:

- completely charged: 1.270 - 1.290
  - needs charging: 1.260 or lower.
7. If the machine will not be in operation for a long period of time, charge the battery sufficiently, tighten all caps correctly, store in cool dry place and check the battery charge level every month to maintain the performance of the battery.

## BATTERY CABLE CONNECTION

1. When removing cable, disconnect the ground side (normally negative) first (Figure 23).



Figure 23. Battery Connection

## FORWARD AND REVERSE TRAVEL ADJUSTMENT

2. If neutral position for forward and reverse travel has been displaced, conduct the neutral adjustment.
3. If roller travels forward with the ball of ball plunger remaining in V slot of the guide, loosen M8 bolt and slide the slide plate slightly toward the engine. If the roller travels backward, slide the plate towards side plate (Figure 24).

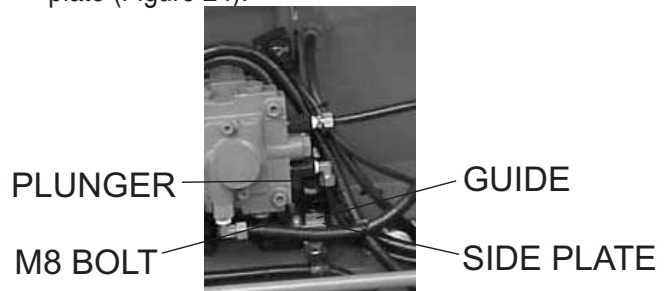
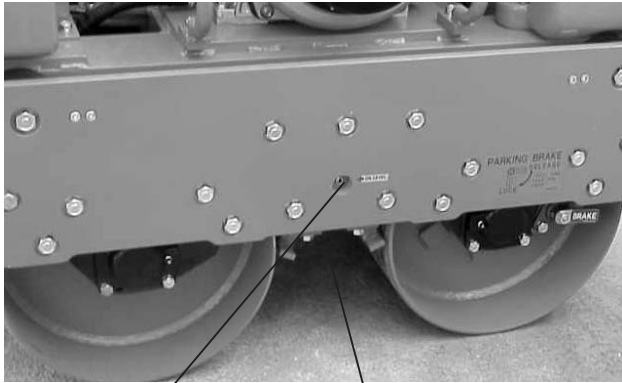

Figure 24. Adjustment of Neutral Position

4. When installing cable, connect the ground side (normally negative) last.
5. With M8 bolt tightened, start engine and check the neutral for forward and reverse. If still displaced, repeat the procedure.
6. If neutral position of forward/reverse lever has been displaced, use the turn buckle located on the oil pump side of forward/reverse cable.

**Table 8. Lubrication Chart**

ITEM	MAINTENANCE NEEDED	FREQUENCY	TYPE	LOCATION
Vibrator Oil	Replace Oil	Every 300 Hours of Operation	SAE10W30 (1.5 liters)	see Figure 25
Engine Oil	Replace Oil	Initially - After 10 to 20 Hours of Operation Thereafter - Every 50 to 100 Hours of Operation	SAE#30 or SAE10W30 (Spring - Summer) SAE#20 or SAE10W30 (Fall - Winter) SAE10W30 (Extremely Cold Region)	see Figure 5
Hydraulic Oil	Replace Oil	Every 1000 to 1500 Hours of Operation	Viscosity: ISO VG32 equivalent - for cold region ISO VG46 or 56 equivalent - for warm region Shipped from factory with Shell Tellus 46 (25 liters)	see Figure 6
Travel Lever, Vibration Lever, Throttle Lever	Add Lubrication Oil to Sliding Parts	Every 50 Hours of Operation	Lubrication Oil	see Figure 3
Dead Man's Device	Lubricate Grease Fitting	Every 50 Hours of Operation	Grease	see Figure 3
Handle Bar Release Pin	Lubricate Grease Fitting	Every 50 Hours of Operation	Grease	see Figure 27
Bearing Cover	Lubricate Grease Fitting	Every 50 Hours of Operation	Grease	see Figure 26
Clutch Box	Lubricate Grease Fitting	Every 50 Hours of Operation	Grease	see Figure 28
Travel Lever	Lubricate Sliding Parts	Every 50 Hours of Operation	Grease	see Figure 3
Oil Filter	Replace Oil Filter	Initially - After 25 Hours of Operation Thereafter - Every 500 Hours of Operation	Mikasa Genuine 10 micron Filter Paper	see Figure 29



VIBRATOR OIL  
LEVEL PLUG

VIBRATOR OIL  
DRAIN PLUG

**Figure 25. Vibrator Oil Maintenance**



BEARING COVER  
GREASE FITTING



BEARING COVER  
GREASE FITTING

**Figure 26. Bearing Cover Maintenance**

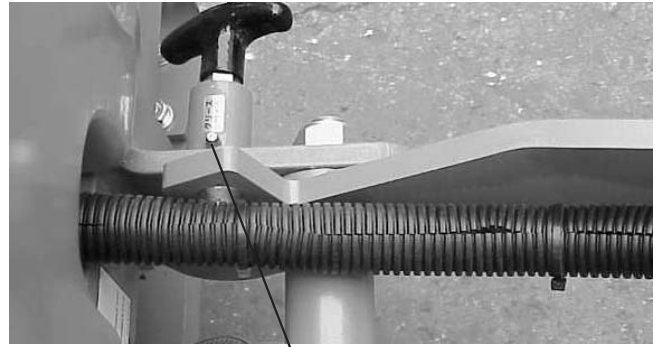

HANDLE BAR RELEASE  
PIN GREASE FITTING

**Figure 27. Handle Bar Maintenance**



CLUTCH BOX  
GREASE FITTING

**Figure 28. Clutch Box Maintenance**



HYDRAULIC OIL FILTER

**Figure 29. Hydraulic Oil Filter Location**



# TROUBLESHOOTING

Troubleshooting - Roller		
SYMPTOM	POSSIBLE PROBLEM	SOLUTION
Unit does not travel.	Parking brake still engaged?	Release parking brake lever.
Unit does not travel or travel is not smooth.	Defective centrifugal clutch?	Repair or replace clutch.
	Damaged rubber coupling and flange?	Replace rubber coupling and flange.
	Defective travel cable and link?	Repair or replace travel cable and link.
	Damaged scraper or too much mud in scraper?	Replace or repair scraper.
	Damaged or clogged oil filter?	Replace filter.
	Damaged or leaking hydraulic pipe?	Repair or replace parts.
	Low oil level or contaminated oil?	Replenish or replace oil.
	Damaged or leaking hydraulic pump?	Repair or replace hydraulic pump.
	Damaged or leaking hydraulic motor?	Repair or replace hydraulic motor.
	Damaged drum gear and bearing?	Repair parts.
Bad drum rotation?	Repair or replace drum.	
Unit does not vibrate or has weak vibration.	Defective centrifugal clutch?	Repair or replace clutch.
	Damaged or slipping V-belt?	Replace V-belt or adjust tension.
	Damaged vibration cable and linkage?	Replace or repair vibration cable and linkage.
	Damaged vibration clutch?	Adjust or replace clutch.
	Defective clutch vibrator pulley V-belt?	Replace V-belt.
	Vibrator does not turn smoothly with hand?	Check and repair vibrator. Check if oil level is not excessively high.

# TROUBLESHOOTING

<b>Troubleshooting (Engine)</b>		
<b>Symptom</b>	<b>Possible Problem</b>	<b>Solution</b>
Engine will not start or start is delayed, although engine can be turned over.	No Fuel reaching injection pump?	Add fuel. Check entire fuel system.
	Defective fuel pump?	Replace fuel pump.
	Fuel filter clogged?	Replace fuel filter and clean tank.
	Faulty fuel supply line?	Replace or repair fuel line.
	Compression too low?	Check piston, cylinder and valves. Adjust or repair per engine repair manual.
	Fuel pump not working correctly?	Repair or replace fuel pump.
	Oil pressure too low?	Check engine oil pressure.
	Low starting temperature limit exceeded?	Comply with cold starting instructions and proper oil viscosity.
	Defective battery?	Charge or replace battery.
	Air or water mixed in fuel system?	Check carefully for loosened fuel line coupling, loose cap nut, etc.
At low temperatures engine will not start.	Engine oil too thick?	Refill engine crankcase with correct type of oil for winter environment.
	Defective battery?	Replace battery.
Engine fires but stops soon as starter is switched off.	Fuel filter blocked?	Replace fuel filter.
	Fuel supply blocked?	Check the entire fuel system.
	Defective fuel pump?	Replace fuel pump.
Engine stops by itself during normal operation.	Fuel tank empty?	Add fuel.
	Fuel filter blocked?	Replace fuel filter.
	Defective fuel pump?	Replace fuel pump.
	Mechanical oil pressure shutdown sensor stops the engine due to low oil?	Add oil. Replace low oil shutdown sensor if necessary.
Low engine power, output and speed.	Fuel tank empty?	Replace fuel filter.
	Fuel filter clogged?	Replace fuel filter.
	Fuel tank venting is inadequate?	Ensure that tank is adequately vented.
	Leaks at pipe unions?	Check threaded pipe unions tape and tighten unions as required.
	Speed control lever does not remain in selected position?	See engine manual for corrective action.
	Engine oil level too full?	Correct engine oil level.
	Injection pump wear?	Use No. 2-D diesel fuel only. Check the fuel injection pump element and delivery valve assembly and replace as necessary.

# TROUBLESHOOTING

Troubleshooting (Engine) - continued		
Symptom	Possible Problem	Solution
Low engine power output and low speed, black exhaust smoke.	Air filter blocked?	Clean or replace air filter.
	Incorrect valve clearances?	Adjust valves per engine specification.
	Malfunction at injector?	See engine manual.
Engine overheats.	Too much oil in engine crankcase?	Drain off engine oil down to uppermark on dipstick.
	Entire cooling air system contaminated/ blocked?	Clean cooling air system and cooling fin areas.
	Fan belt broken or elongated?	Change belt or adjust belt tension.
	Coolant insufficient?	Replenish coolant.
	Radiator net or radiator fin clogged with dust?	Clean net or fin carefully.
	Fan, radiator, or radiator cap defective?	Replace defective part.
	Thermostat defective?	Check thermostat and replace if necessary.
	Head gasket defective or water leakage?	Replace parts.

# EXPLANATION OF CODE IN REMARKS COLUMN

The following section explains the different symbols and remarks used in the Parts section of this manual. Use the help numbers found on the back page of the manual if there are any questions.

**NOTICE**

The contents and part numbers listed in the parts section are subject to change **without notice**. Multiquip does not guarantee the availability of the parts listed.

## SAMPLE PARTS LIST

NO.	PART NO.	PART NAME	QTY.	REMARKS
1	12345	BOLT .....	1	INCLUDES ITEMS W/%
2%		WASHER, 1/4 IN. ....		NOT SOLD SEPARATELY
2%	12347	WASHER, 3/8 IN. ...	1	MQ-45T ONLY
3	12348	HOSE .....	A/R	MAKE LOCALLY
4	12349	BEARING .....	1	S/N 2345B AND ABOVE

## NO. Column

**Unique Symbols** — All items with same unique symbol

(@, #, +, %, or >) in the number column belong to the same assembly or kit, which is indicated by a note in the “Remarks” column.

**Duplicate Item Numbers** — Duplicate numbers indicate multiple part numbers, which are in effect for the same general item, such as different size saw blade guards in use or a part that has been updated on newer versions of the same machine.

**NOTICE**

When ordering a part that has more than one item number listed, check the remarks column for help in determining the proper part to order.

## PART NO. Column

**Numbers Used** — Part numbers can be indicated by a number, a blank entry, or TBD.

TBD (To Be Determined) is generally used to show a part that has not been assigned a formal part number at the time of publication.

A blank entry generally indicates that the item is not sold separately or is not sold by Multiquip. Other entries will be clarified in the “Remarks” Column.

## QTY. Column

**Numbers Used** — Item quantity can be indicated by a number, a blank entry, or A/R.

A/R (As Required) is generally used for hoses or other parts that are sold in bulk and cut to length.

A blank entry generally indicates that the item is not sold separately. Other entries will be clarified in the “Remarks” Column.

## REMARKS Column

Some of the most common notes found in the “Remarks” Column are listed below. Other additional notes needed to describe the item can also be shown.

**Assembly/Kit** — All items on the parts list with the same unique symbol will be included when this item is purchased.

Indicated by:

“INCLUDES ITEMS W/(unique symbol)”

**Serial Number Break** — Used to list an effective serial number range where a particular part is used.

Indicated by:

“S/N XXXXX AND BELOW”

“S/N XXXX AND ABOVE”

“S/N XXXX TO S/N XXX”

**Specific Model Number Use** — Indicates that the part is used only with the specific model number or model number variant listed. It can also be used to show a part is NOT used on a specific model or model number variant.

Indicated by:

“XXXXX ONLY”

“NOT USED ON XXXX”

**“Make/Obtain Locally”** — Indicates that the part can be purchased at any hardware shop or made out of available items. Examples include battery cables, shims, and certain washers and nuts.

**“Not Sold Separately”** — Indicates that an item cannot be purchased as a separate item and is either part of an assembly/kit that can be purchased, or is not available for sale through Multiquip.

## SUGGESTED SPARE PARTS

### MRH800DS2 VIBRATORY ROLLER WITH YANMAR L100V1AJ1R1AAMK DIESEL ENGINE

1 to 3 units

Qty.	P/N	Description
1.....	954407840.....	FILTER, WATER TANK
2.....	954001380.....	FILTER, HYDRAULIC OIL
2.....	070503000.....	V-BELT, ENGINE
1.....	956100022.....	THROTTLE WIRE
1.....	954300342.....	CAP, WATER TANK
2.....	070100381.....	V-BELT, VIBRATOR ASSY.
1.....	71421053100.....	VALVE ASSY., FUEL INJECTOR
1.....	71434951400.....	PUMP ASSY., FUEL INJECTOR
3.....	11421012590.....	ELEMENT, AIR CLEANER
1.....	11428855041.....	CAP ASSY., FUEL TANK
2.....	11429935110.....	STRAINER, LUB. OIL ASSY.
1.....	11429955100.....	FILTER, FUEL STRAINER
2.....	11425055121.....	FILTER, FUEL OIL
2.....	955000010.....	KEY, STARTING

#### NOTICE

Part numbers on this Suggested Spare Parts list may supersede/replace the part numbers shown in the following parts lists.



## NAMEPLATES AND DECALS

<u>NO.</u>	<u>PART NO.</u>	<u>PART NAME</u>	<u>QTY.</u>	<u>REMARKS</u>
1	920205690	DECAL, BRAKE LEVER.....	1.....	NPA-569
2	920209660	DECAL, CAUTION - ENGINE SPEED.....	1.....	NPA-966
3	920206280	DECAL, DANGER - PINCH POINT .....	1.....	NPA-628
4	920102490	DECAL, LIGHT SWITCH .....	1.....	NP-249
5	920101480	DECAL, CHECK OIL LEVEL .....	1.....	NP-148
6	DCL210	DECAL, MIKASA MOBILE DTE 25	1	
7	920108070	DECAL, FORWARD/REVERSE LEVER.....	1.....	NPA-807
8	920100120	DECAL, GREASE POINT .....	1.....	NPA-120
9	920208070	DECAL, PARKING BRAKE .....	1.....	NPA-807
10	920206160	DECAL, CAUTION - INCLINE PARKING.....	1.....	NPA-616
11	920206200	DECAL, WATER TANK SPRINKLE PIPE.....	1.....	NPA-620
12	920203330	DECAL, HEARING PROTECTION .....	1.....	NPA-333
13	920201910	DECAL, MULTIQUIP - CARSON .....	1.....	NPA-191
14	920101510	DECAL, MIKASA .....	1.....	NP-151
15	920200320	DECAL, WATER TANK.....	1.....	NP-32
16	920207620	DECAL, MRH-800DS.....	1.....	NPA-762
17	920206290	DECAL, CAUTION - OWNERS MANUAL.....	1.....	NPA-629
18	920202810	DECAL, CAUTION - VIBRATION LEVER .....	1.....	NPA-281
19	920104280	DECAL, FREEZING PREVENTION .....	1.....	NPA-428
20	920213000	DECAL, OIL TANK .....	1.....	NPA-1300
21	920207870	DECAL, CAUTION - INSTRUCTIONS PLATE ..	1.....	NPA-787
22	920205640	DECAL, WARNING - INCLINE PARKING.....	1.....	NPA-564
23	920105170	DECAL, THROTTLE .....	1.....	NPA-517
24	920207860	DECAL, CAUTION - MOVING PLATE .....	1.....	NPA-786
25	920201450	DECAL, HORN .....	1.....	NPA-145
26	920202920	DECAL, CAUTION - STARTING ENGINE .....	1.....	NPA-292
27	920207880	DECAL, WARNING - INCLINE PLATE.....	1.....	NPA-788
28	920106760	DECAL, IGNITION.....	1.....	NPA-676
29	920106790	DECAL, V-BELT (A-38 RED).....	1.....	NP-679
30	920106780	DECAL, V-BELT (3V-300) .....	1.....	NP-678
31	515010080	DECAL, WINDOW SHADE RIVET .....	12.....	NSA3-4
32	920205080	DECAL, ON-OFF .....	1.....	NPA-508
33	920214100	DECAL, E/G FIRE WARNING .....	1.....	NPA-1410
34	920206080	DECAL, E/G THROTTLE DIAL/E.....	1.....	NPA-608
35	920202910	DECAL, BUZZER (HYDRAULIC).....	1.....	NPA-291



# AXLE ASSY.

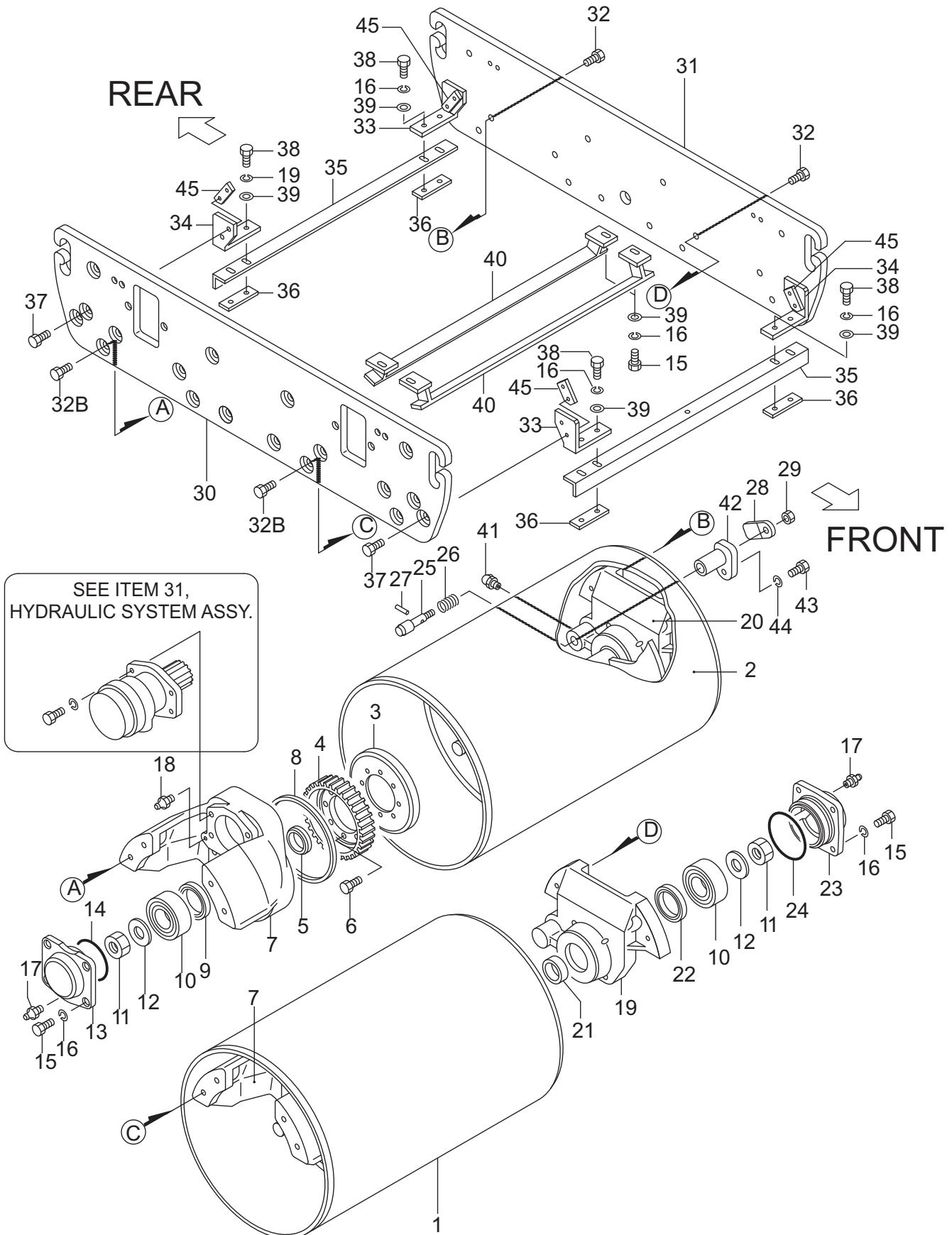



## AXLE ASSY.

<u>NO.</u>	<u>PART NO.</u>	<u>PART NAME</u>	<u>QTY.</u>	<u>REMARKS</u>
1	515119290	DRUM	1	
2	515119300	DRUM, B	1	
3	515346670	GEAR PLATE	2	
4	515334000	GEAR (39)	2	
5	509429660	COLLAR 405510	2	
6	001221035	BOLT 10X35 T	16	
7	515118960	DRUM BRACKET (R)	2	
8	515460540	V-RING V-200L	2	
9	060605020	OIL SEAL VC-55727	2	
10	047110030	BEARING 6308FY	4	
11	020130240	NUT M30, P2.0	4	
12	031130450	WASHER M30	4	
13	515334010	BEARING COVER (R)	2	
14	050100850	O-RING G-85	2	
15	001221025	BOLT 10X25 T	20	
16	030210250	WASHER M10	28	
17	301010100	GREASE FITTING A-PT1/8	4	
18	351010050	GREASE FITTING A-MT6X1	4	
19	515113000	DRUM BRACKET (L)	1	
20	515113014	DRUM BRACKET (LB)	1	
21	506425670	COLLAR 405520	2	
22	060705010	OIL SEAL TB4-55729	2	
23	515334040	BEARING COVER (L)	2	
24	050300950	O-RING S-95	2	
25	515446960	LOCK PUN, BRAKE	1	
26	515446950	SPRING, BRAKE	1	
27	025405025	SPRING PIN 5X25	1	
28	515446970	KNOB, BRAKE	1	
29	020410060	NUT M10, H=6	1	
30	515117040	SIDE PLATE (R)	1	
31	515114350	SIDE PLATE (L)	1	
32	001121630	BOLT 16X30 T, P1.5	8	
33	515341930	BRACKET (A), SCRAPER	2	
34	515341940	VRACKET (B), SCRAPER	2	
35	515334020	SCRAPER (OUT)	2	
36	515447510	MOUNT NUT, SCRAPER	4	
37	001121435	BOLT 14X35 T	8	
38	001221030	BOLT 10X30 T	8	
39	031110160	WASHER M10	12	
40	515334030	SCRAPER (IN)	2	
41	959010330	GREASE FITTING B-M6FX1	1	
42	515340410	SOCKET (BRAKE)	1	
43	001221025	BOLT 10X25 T	1	
44	030210250	WASHER M10	1	
45	515455840	MOUNT NUT(M14),SCRAPER	4	

# BASE ASSY.

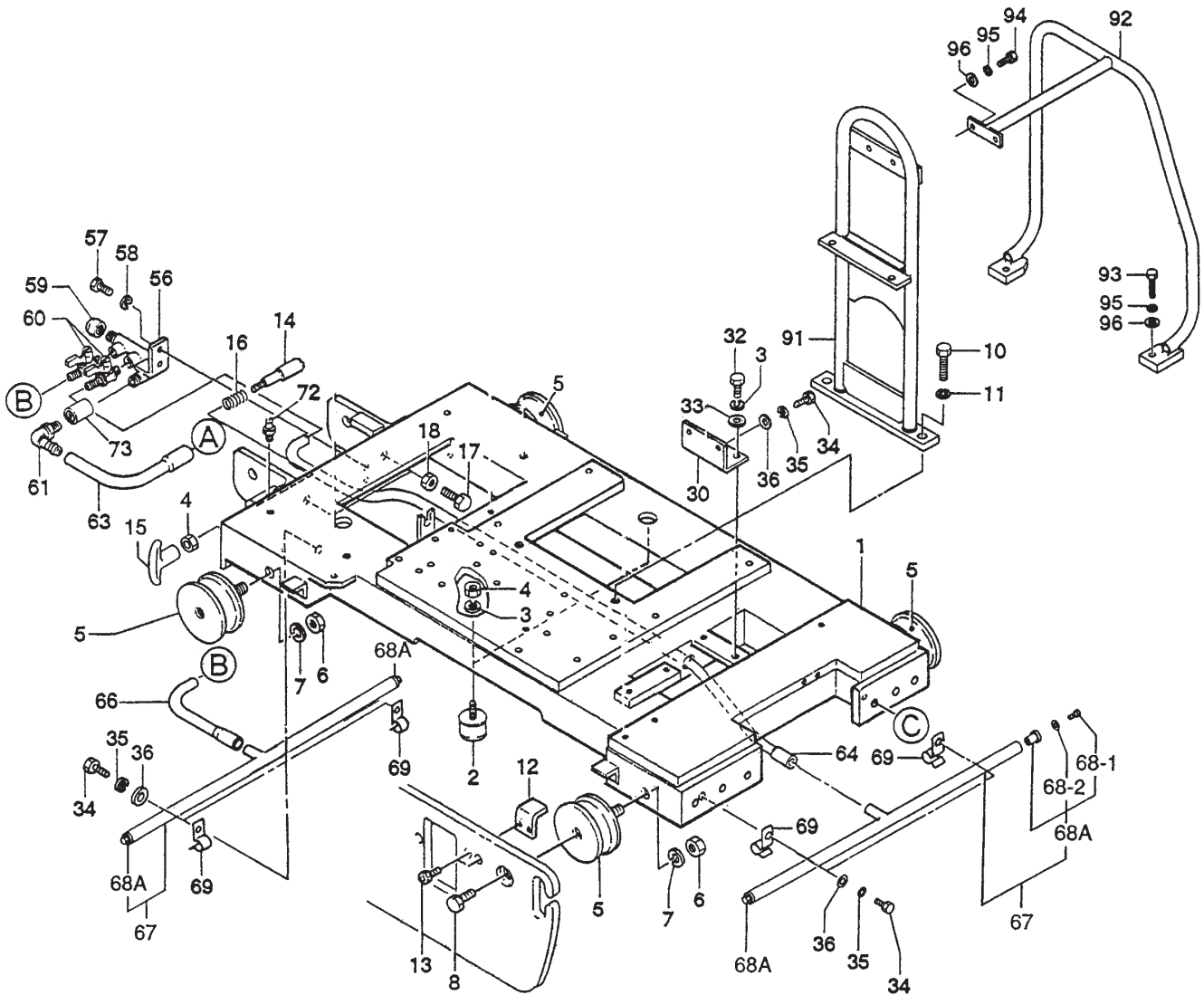

# BASE ASSY.

<u>NO.</u>	<u>PART NO.</u>	<u>PART NAME</u>	<u>QTY.</u>	<u>REMARKS</u>
1	515119150	BASE (YANMAR-L100)	1	
2	939010010	SHOCK ABSORBER, STOPPER 45	2	
3	030210250	WASHER, LOCK M10	9	
4	020310080	NUT M10	2	
5	930710031	SHOCK ABSORBER RV1-100	4	
6	020316130	NUT M16	4	
7	030216400	WASHER, LOCK M16	4	
8	001221625	BOLT 16X25 T	4	
10	001221440	BOLT 14X40 T	2	
11	030214350	WASHER, LOCK M14	2	
12	515447010	SAFETY GUARD	4	
13	001520815	SOCKET HEAD BOLT 8X13 T	8	
14	515454970	HANDLE STOPPER	1	
15	959007140	T- KNOB (M12)	1	
16	517459700	SPRING / HANDLE	1	
17	001221230	BOLT 12X30 T	2	
18	020312100	NUT M12	3	
30	515334100	STAY, COVER (F)	1	
32	001221020	BOLT 10X20 T	5	
33	031110160	WASHER, FLAT M10	7	
34	0105050616	BOLT 6X15 T.....	8.....	REPLACES 001220615
35	030206150	WASHER, LOCK M6	8	
36	952404470	WASHER, FLAT M6.....	8.....	REPLACES 031106100
56	515334050	SUPPORT , WATER COCK	1	
57	014208020	BOLT 8X20 T.....	2.....	REPLACES 001220820
58	030208200	WASHER, LOCK M8	2	
59	509010010	CAP 3/8	1	
60	954403241	COCK PT1/4, BH-1211 (AL)	2	
61	954405660	ELBOW 3/8X12	1	
63	515446980	WATER HOSE (T-V) 300L	1	
64	515446990	WATER HOSE (F) 1200L	1	
66	515447470	WATER HOSE (R) 260L	1	
67	515910040	SPRINKLING PIPE ASSY.....	2.....	INCLUDES ITEMS W/ *
68A*	515910050	CAP ASSY, W/ BOLT, WASHER .....	4.....	INCLUDES ITEMS W/ +
68-1+	001220620	BOLT 6X20 T	4	
68-2+	031106100	WASHER, FLAT M6	4	
69	515449900	CLAMP	4	
72	351010050	GREASE FITTING A-MT6X1	1	
73	954001590	SOCKET PT3/8-3/8	1	
91	515213600	HOOK (L100)	1	
92	515113710	GUARD (L100)	1	
93	001221035	BOLT 10X35T	2	
94	001221020	BOLT 10X20T	2	
95	030210250	WASHER, LOCK M10	4	
96	031110160	WASHER, FLAT M10	4	

# FRONT GUARD ASSY.

FRONT OF BASE

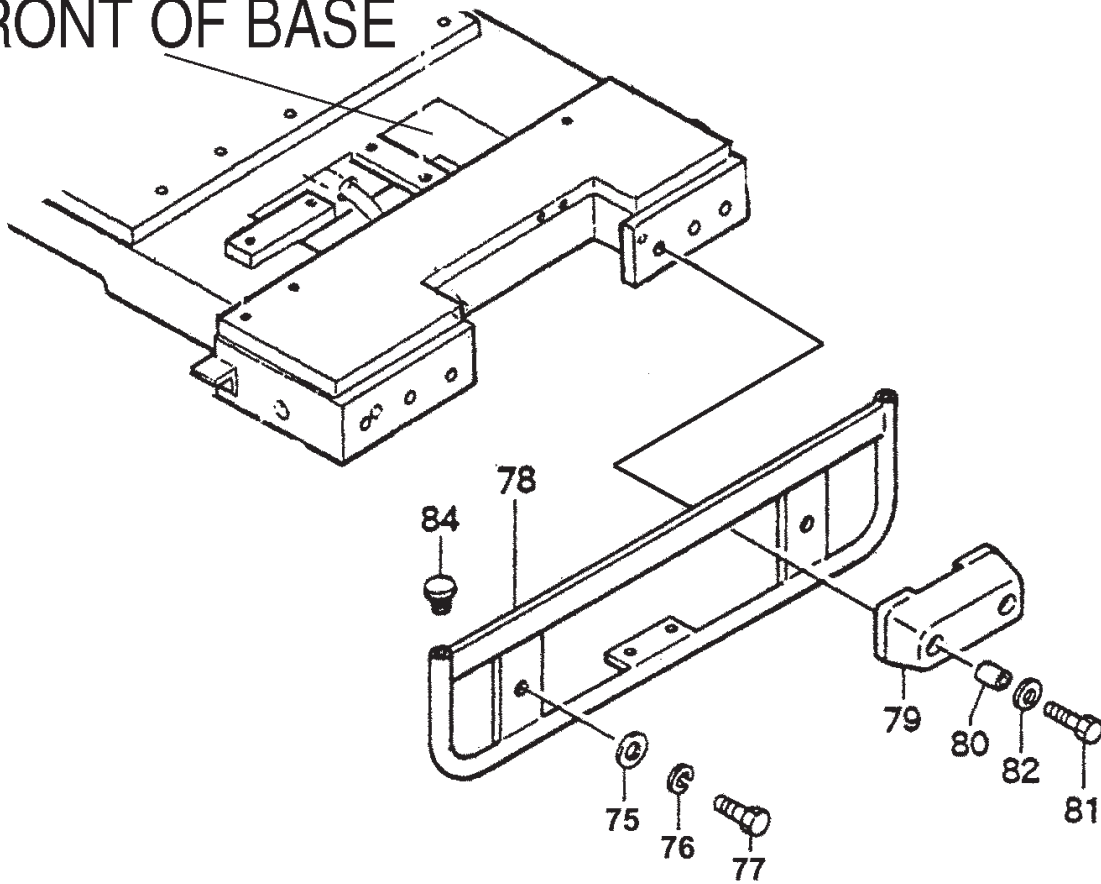

## FRONT GUARD ASSY.

---

<u>NO.</u>	<u>PART NO.</u>	<u>PART NAME</u>	<u>QTY.</u>	<u>REMARKS</u>
75	031110160	FLAT WASHER, M10	2	
76	030210250	LOCK WASHER, M10	2	
77	001221035	BOLT 10X35 MM	2	
78	515336200	FRONT GUARD	1	
79	515336210	BUMPER	2	
80	515449720	SPACER, BUMPER	4	
81	001221040	BOLT 10X40 T	4	
82	031110160	WASHER, FLAT M10	4	
84	953405940	PIPE INSERT PZ-7	2	

# SIDE COVER ASSY.

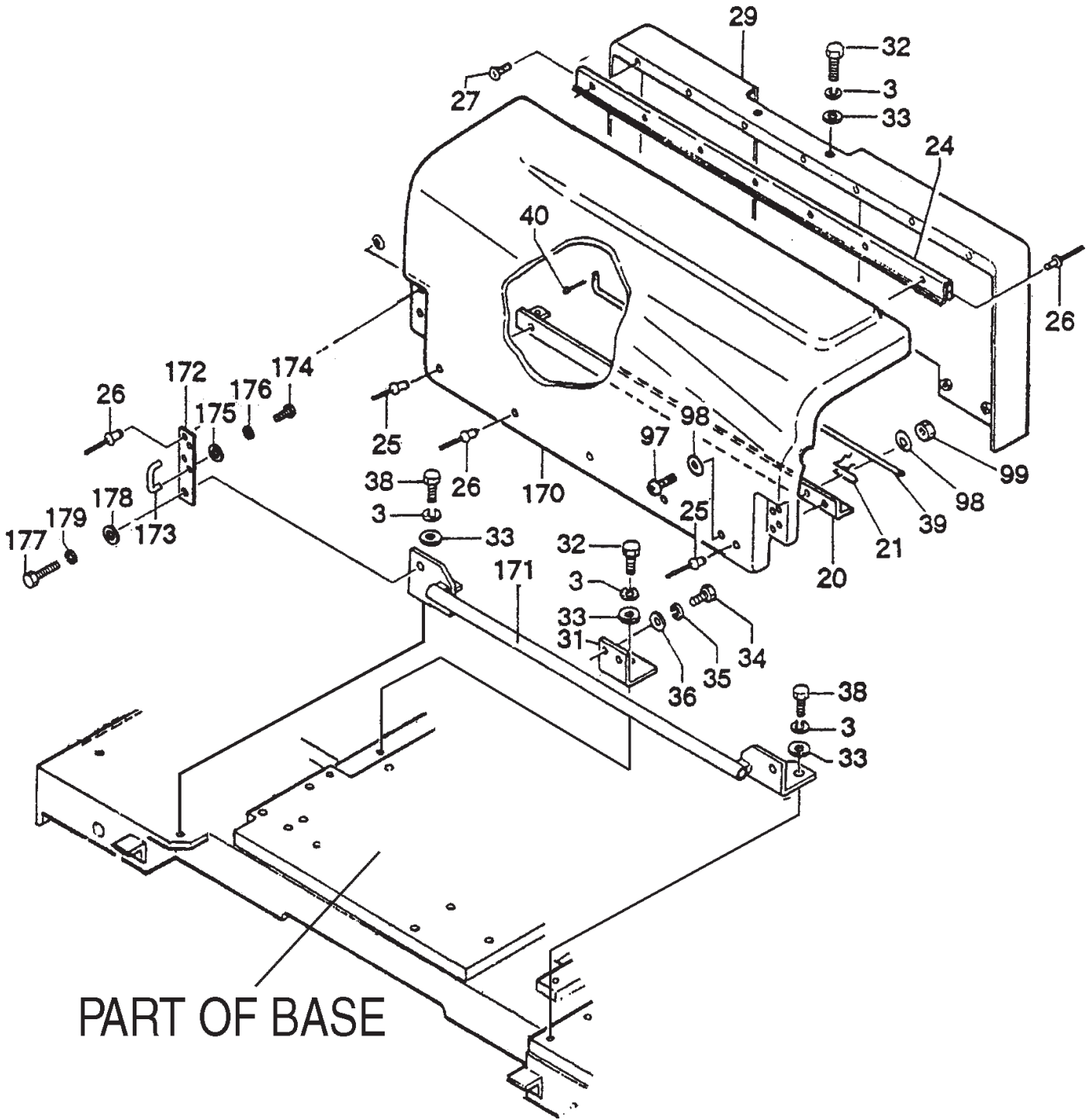

## SIDE COVER ASSY.

<u>NO.</u>	<u>PART NO.</u>	<u>PART NAME</u>	<u>QTY.</u>	<u>REMARKS</u>
3	030210250	WASHER, LOCK M10	9	
20	515336250	SUPPORT, COVER	1	
21	515449890	ROD HOLDER	1	
24	515334600	RUBBER HINGE	1	
25	515010090	RIVET	2	
26	515010100	RIVET	14	
27	092004008	SCREW 4X8	7	
29	515113080	COVER, E/G	1	
31	515447030	STAY, COVER (R)	1	
32	012210020	BOLT 10X20 T.....	5.....	REPLACES 001221020
33	031110160	WASHER, FLAT M10	7	
34	0105050616	BOLT 6X15 T.....	8.....	REPLACES 001220615
35	030206150	WASHER, LOCK M6	8	
36	952404470	WASHER, FLAT M6.....	8.....	REPLACES 031106100
38	0105091025	BOLT 10X25 T.....	2.....	REPLACES 001221025
39	515447380	ROD, COVER	1	
40	025910060	SNAP PIN 6	1	
97	091004016	SCREW 4X16	1	
98	031104080	WASHER, FLAT M4	2	
99	020304030	NUT M4	1	
170	515910100	COVER (ASSY)	1	
171	515214241	STAY, COVER (EXP)	1	
172	515450780	HANDLE BRACKET	2	
173	515450790	HANDLE (COVER)	2	
174	091004015	SCREW 4X15	4	
175	031104080	WASHER, FLAT M4	4	
176	030204100	WASHER, LOCK M4	4	
177	001220815	BOLT 8X15 T	2	
178	031108160	WASHER, FLAT M8	2	
179	030208200	WASHER, LOCK M8	2	





## WATER TANK ASSY.

---

<u>NO.</u>	<u>PART NO.</u>	<u>PART NAME</u>	<u>QTY.</u>	<u>REMARKS</u>
41	515119400	WATER TANK	1	
42	954300342	CAP, WATER TANK /MR	1	
43	001241030	BOLT 10X30 U	1	
44	033910010	WASHER 10.5X21X2 SUS	2	
45	022910180	NYLON NUT M10 (SUS)	1	
46	954404910	HOSE JOINT 17D	1	
47	954404840	FILTER, TANK /MR	1	
48	953404900	PACKING 26X36X3	2	
49	959404880	NUT 3/4	2	
50	506403990	CAP PS1	2	
51	953404000	PACKING, CAP PS1	1	
52	506434680	STOPPER, FRONT	2	
53	506434690	SPACER, WATER TANK 39L	4	
54	001221253	BOLT 12X65 T	4	
55	030212300	WASHER, LOCK M12	4	
62	954405680	CONNECTOR 1/4x10	2	
65	516454950	WATER HOSE (T) 330L	1	
70	515449870	HOLDER, STOPPER	2	
71	517338540	STOPPER	2	
74	001220610	BOLT 6X10 T	4	
75	031106100	WASHER, FLAT M6	4	
76	030206150	WASHER, LOCK M6	4	
86	515449880	HOLDER (R)	2	
87	952405950	WASHER 13506	2	

# HYDRAULIC SYSTEM ASSY.

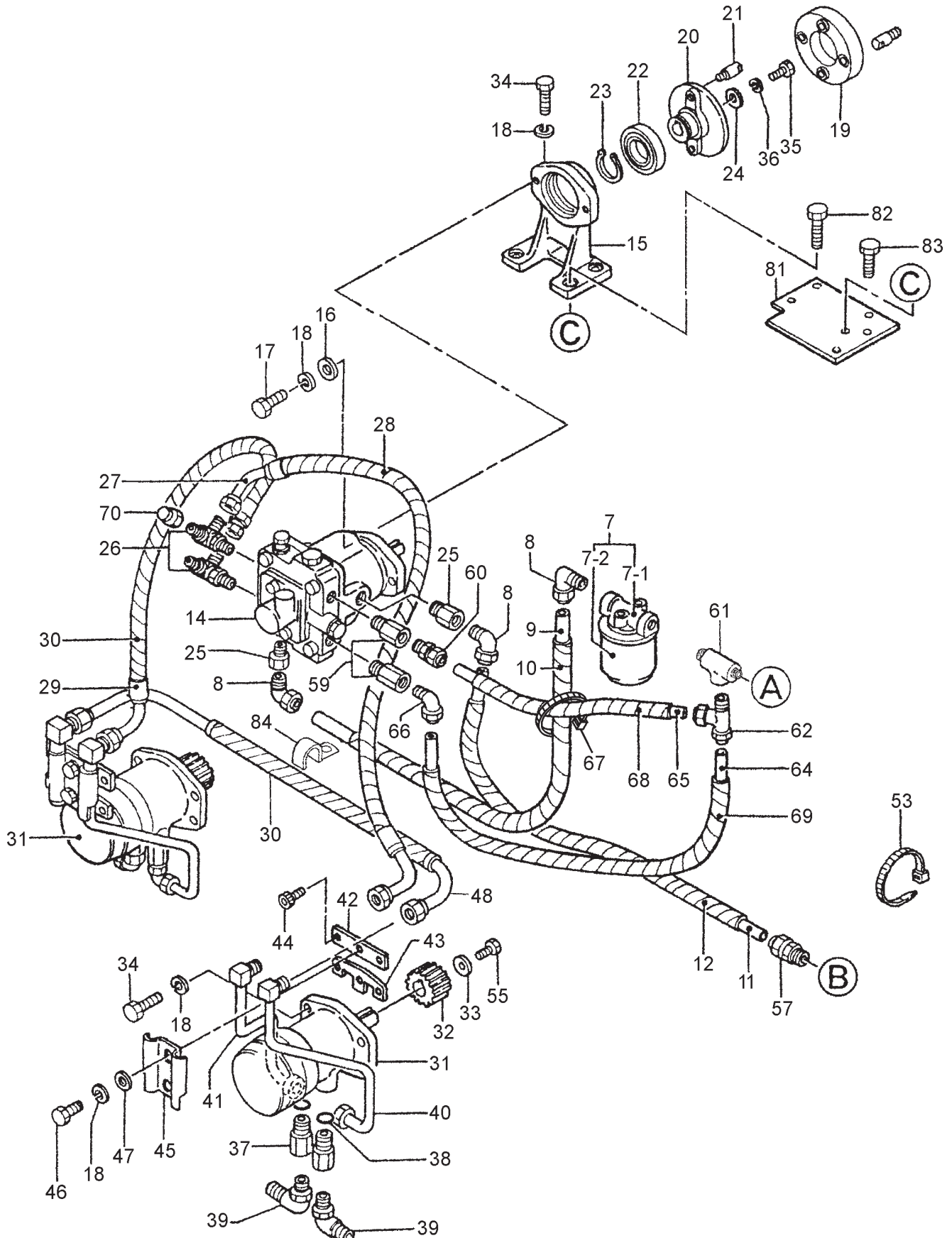

## HYDRAULIC SYSTEM ASSY.

<u>NO.</u>	<u>PART NO.</u>	<u>PART NAME</u>	<u>QTY.</u>	<u>REMARKS</u>
7	954001350	OIL FILTER CPO 3-80 .....	1.....	INCLUDES ITEMS W/ *
7-1*	954001390	FILTER HEAD	1	
7-2*	954001380	OIL ELEMENT	1	
8	954001530	ELBOW LIN-1/2-PT3/8	3	
9	954002310	TUBE 9.6-12.7 - 325L	1	
10	959020014	SPIRAL TUBE 11D-350L	1	
11	954001511	TUBE 9.6-12.7-360	1	
12	959020014	SPIRAL TUBE 11D-400L	1	
14	515010050	OIL PUMP PV10-610	1	
14	515010110	OIL PUMP PV10 -625	1	
15	515114390	BRACKET (PV10)	1	
16	952404110	COLLAR 10225	2	
17	012210035	BOLT 10X35 T.....	2.....	REPLACES 001221035
18	030210250	WASHER, LOCK M10	22	
19	515334070	COUPLING	1	
20	515334080	FLANGE (PV10)	1	
21	515447020	COUPLING PIN	2	
22	046006009	BEARING 6009DDU	1	
23	080200450	STOP RING S -45	1	
24	952400450	WASHER 7X30X4.5	1	
25	954001460	BUSHING CP-3/8	2	
26	954001850	ELBOW 3/8 - 1/4X2	2	
27	954001370	OIL HOSE ML90-ML90X560	1	
27	954001830	OIL HOSE ML90-ML90X560 BS	1	
28	959020013	SPIRAL TUBE 11D-600L	1	
29	516010080	OIL HOSE ML90-1005X600	1	
29	954001840	OIL HOSE ML90-1005X600 BS	1	
30	955404270	SPIRAL TUBE/11D-700L	1	
31	515010040	OIL MOTOR K2355(BLUE)	2	
32	515454330	PINION (12)	2	
33	952400130	WASHER 9304	2	
34	012210035	BOLT 10X35 T.....	14.....	REPLACES 001221035
35	0105050616	BOLT 6X15 T.....	2.....	REPLACES 001220615
36	030206150	WASHER, LOCK M6	2	
37	515447130	JOINT 1/2-3/8-31	4	
38	050210180	O-RING P-18-1B	4	
39	512010120	JOINT, LLM-UE-10X3/8-B	4	
40	515447110	PIPE, OM-A-E	2	
41	515447120	PIPE, OM-B-E	2	

# HYDRAULIC SYSTEM ASSY.

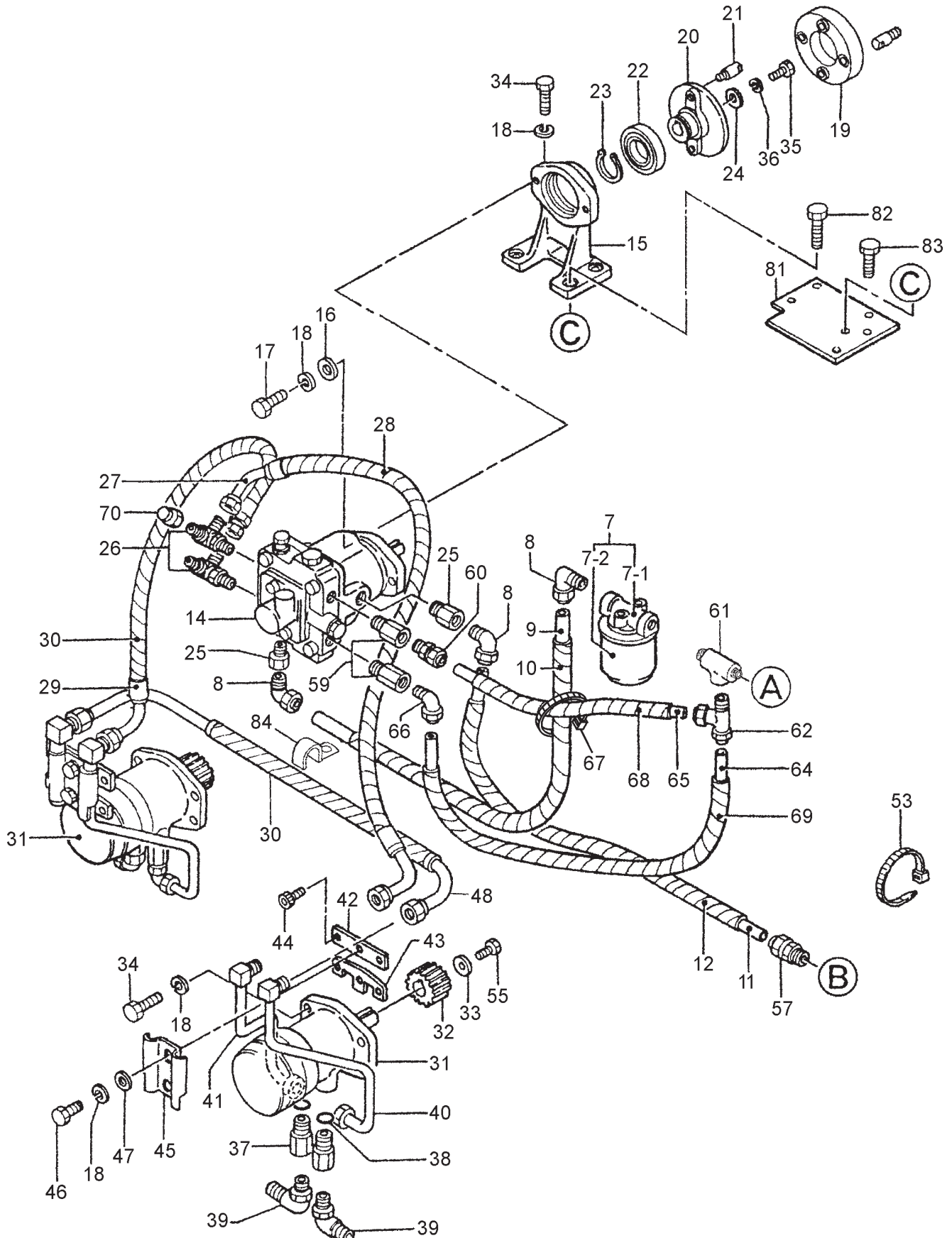

## HYDRAULIC SYSTEM ASSY.

### CONTINUED

<u>NO.</u>	<u>PART NO.</u>	<u>PART NAME</u>	<u>QTY.</u>	<u>REMARKS</u>
42	515447160	HOLDER, UPPER	2	
43	515447170	HOLDER, LOWER	2	
44	001520820	SOCKET HEAD BOLT 8X20 T	8	
45	515447140	COVER, PIPE	2	
46	012221020	BOLT 10X20 T	4	
47	031110160	WASHER, FLAT M10	8	
48	954002630	OIL HOSE ML90-700BS	1	
53	507010110	CLAMP TC-200	5	
55	014208020	BOLT 8X20 T.....	4.....	REPLACES 001220820
56	030208200	WASHER, LOCK M8	2	
57	954001520	ADAPTER CIN-1/2XPT3/8	1	
59	515335300	CHECK VALVE 7/16	2	
60	954001090	ADAPTER CIN-3/8-PT1/4	1	
61	954002660	T-JOINT 3/8	1	
62	954001620	FITTING, TEE STIN3/8-PT3/8	1	
64	954090004	TUBE 9.5-7-405L	1	
65	954090005	TUBE 9.5-7-305L	1	
66	954001100	ELBOW LIN-3/8-PT1/4	1	
67	454010020	CLAMP TC-100	12	
68	959021810	SPIRAL TUBE KEP-6/L-500	1	
69	959021810	SPIRAL TUBE 6D-510L	1	
70	954001040	CAP PF1/4	2	
81	515335451	SPACER (PV10)	1	
82	0109051045	BOLT 10X40 T.....	4.....	REPLACES 001221040
83	012010030	BOLT 10X30 T.....	2.....	REPLACES 001221030
84	954405550	CLAMP 15R	2	

# HYDRAULIC OIL TANK ASSY.

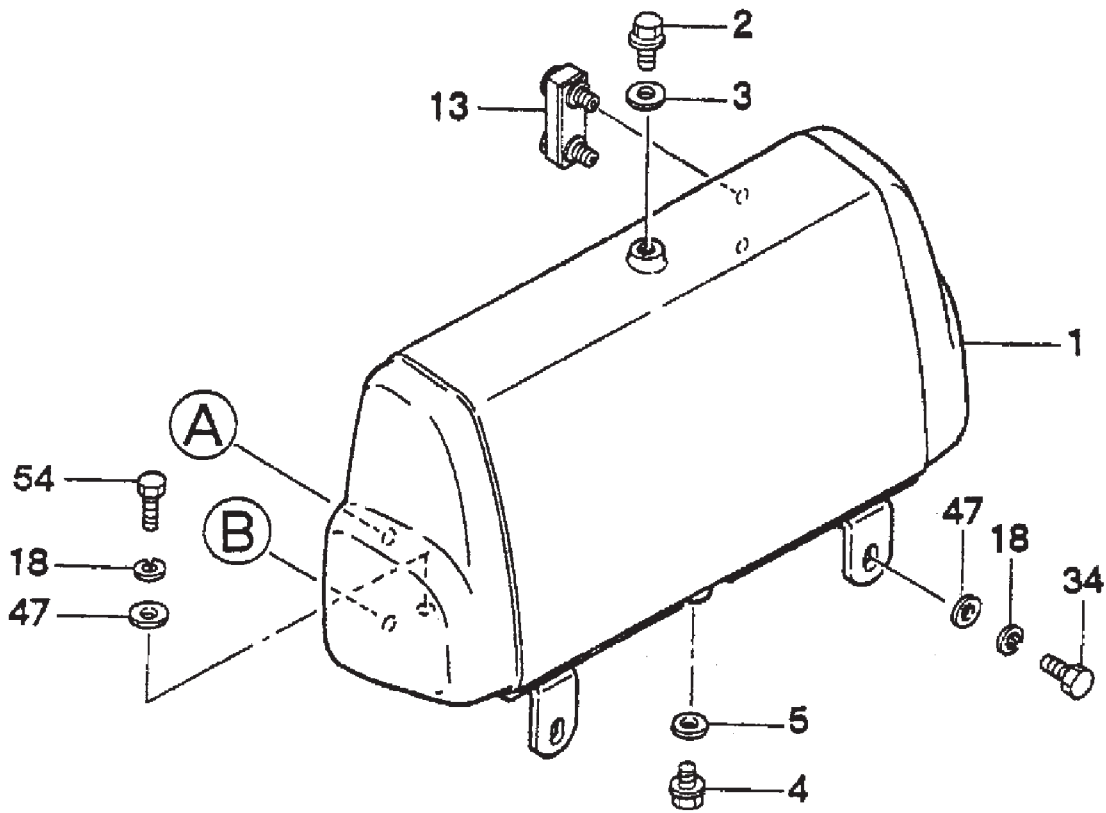

**A** NOTE: SEE HYDRAULIC SYSTEM ASSY. FOR OIL TANK HOSE CONNECTIONS.  
**B**

## HYDRAULIC OIL TANK ASSY.

---

<u>NO.</u>	<u>PART NO.</u>	<u>PART NAME</u>	<u>QTY.</u>	<u>REMARKS</u>
1	515118050	OIL TANK , (N)	1	
2	953405840	DRAIN PLUG M18	1	
3	953402930	COPPER PACKING 19X30X1	1	
4	953400270	PLUG 1/4X14 10L	1	
5	953405260	PACKING 1/4 (CU)	1	
13	955407500	OIL GAUGE/KLA-60-A-B	1	
18	030210250	WASHER, LOCK M10	22	
34	012210035	BOLT 10X35 T.....	14.....	REPLACES 001221035
47	031110160	WASHER, FLAT M10 IN SYSTEM	8	
54	0105091025	BOLT 10X25 T.....	2.....	REPLACES 001221025



# ENGINE ASSY.

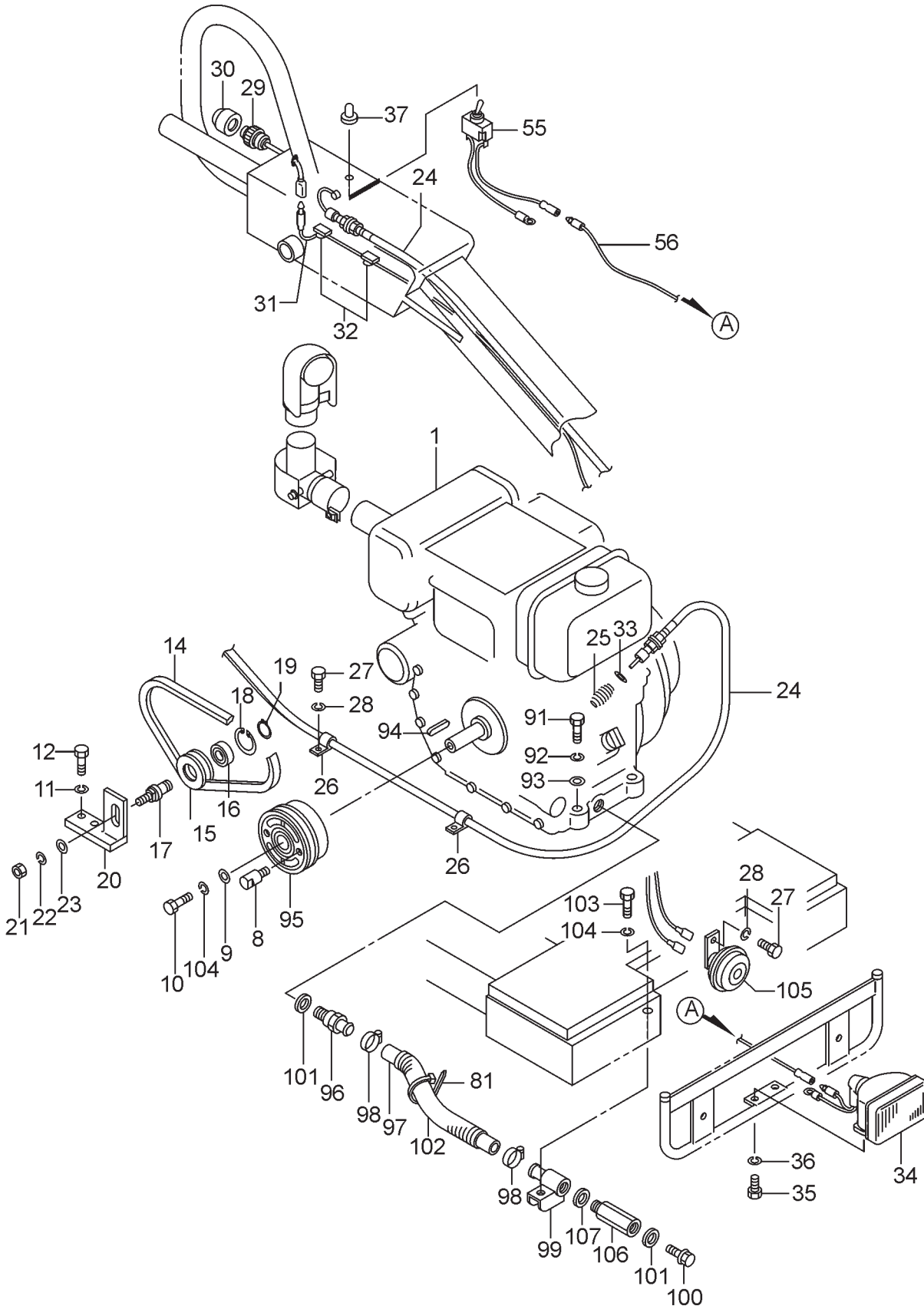

# ENGINE ASSY.

<u>NO.</u>	<u>PART NO.</u>	<u>PART NAME</u>	<u>QTY.</u>	<u>REMARKS</u>
1	914410028	ENGINE ASSY, L100V1AJ1R1AAMK	1	
8	515447020	COUPLING PIN	2	
9	952400690	WASHER 9X35X4.5	1	
10	011208025	BOLT 8X25 T .....	1	REPLACES 001220825
11	030210250	WASHER, LOCK M10	2	
12	012010030	BOLT 10X30 T .....	2	REPLACES 001221030
14	070503000	V-BELT 3V- 300	1	
15	515447050	TIGHTENER PULLEY	1	
16	046006004	BEARING 6004DDU	1	
17	515447060	SHAFT, TIGHTENER	1	
18	080100420	STOP RING R-42	1	
19	080200200	STOP RING S-20	1	
20	515334180	HOLDER, TIGHTENER	1	
21	020314110	NUT M14	1	
22	030214350	WASHER, LOCK M14	1	
23	031114260	WASHER, FLAT M14	1	
24	956100022	THROTTLE WIRE 2560-2700	1	
25	2344600213	RETURN SPRING	1	
26	607010040	CLAMP CLA-3200 (7D)	2	
27	001220610	BOLT 6X10 T	3	
28	030206150	WASHER, LOCK M6	3	
29	955400800	HORN BUTTON ASSY	1	
30	955405980	COVER, HORN BUTTON	1	
31	515447320	READ CORD, HORN (WASHER, LOCK)	1	
32	955405710	WIRE CLAMP	2	
33	031104080	WASHER,FLAT M4	1	
34	955200030	HEAD LAMP ASSY 12V-25W	1	
35	0105050616	BOLT 6X15 T .....	2	REPLACES 001220615
36	030206150	WASHER, LOCK M6	2	
37	304402600	CAP	1	
55	515447740	SWITCH W/CORD	1	
56	515449920	READ CORD (LAMP)	1	
81	506010070	CLAMP TC-150	3	
91	012210040	BOLT 10X40 T .....	4	REPLACES 001221040
92	030210250	WASHER, LOCK M10	4	
93	031110160	WASHER, FLAT M10	4	
94	951405770	KEY 7X7X36 RR	1	
95	515338240	ENGINE PULLEY 130D (L100)	1	
96	515448720	NIPPLE, DRAIN	1	
97	515448730	PIPE, OIL DRAIN	1	
98	515448740	HOSE CLIP	2	
99	515448750	JOINT, DRAIN	1	
100	515448760	DRAIN PLUG	1	
101	515448770	SEAL WASHER	2	
102	959026011	TUBE 20D-300L	1	
103	959401890	BOLT 8X15	1	
104	030208200	WASHER, LOCK M8	2	
105	955300420	HORN (DC12V)	1	
106	515452330	DRAIN UNION	1	
107	953404670	COPPER PACKING 17 X 25.5 X 1	1	

# ELECTRIC DEVICE ASSY.

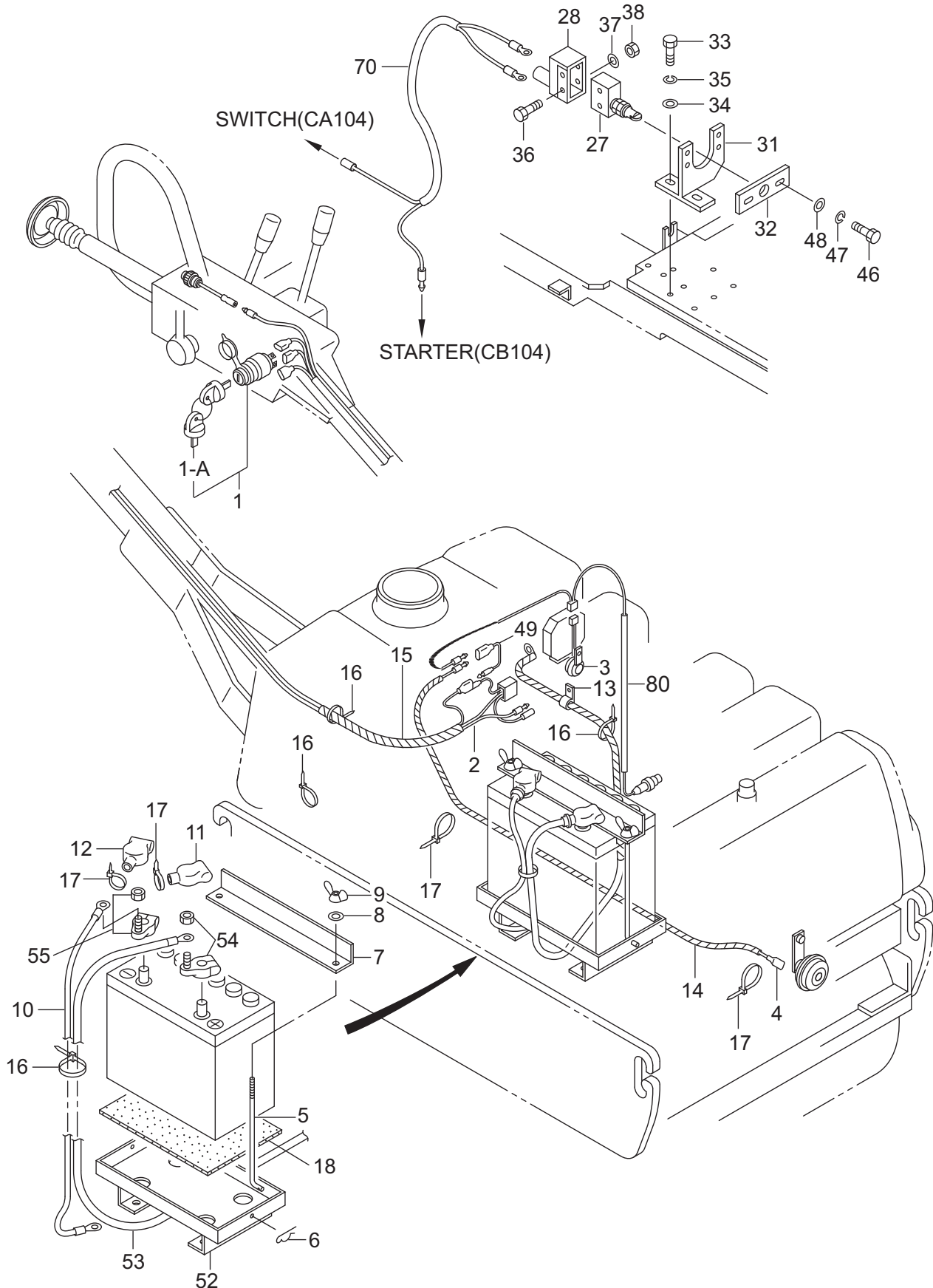

## ELECTRIC DEVICE ASSY.

<u>NO.</u>	<u>PART NO.</u>	<u>PART NAME</u>	<u>QTY.</u>	<u>REMARKS</u>
1	955300680	KEY SWITCH .....	1.....	INCLUDES ITEMS W/ *
1A*	955000010	KEY, STARTER SWITCH ASSY	1	
2	515460020	WIRE HARNESS (L100V)	1	
3	955300400	BUZZER (EBL)	1	
4	515449860	HARNESS (L1200)	1	
5	515448210	ROD, BATTERY	2	
6	607010080	COTTER PIN 6	2	
7	516455640	HOLDER, BATTERY	1	
8	952404470	WASHER, FLAT M6.....	2.....	REPLACES 031106100
9	0037806000	WING NUT M6.....	2.....	REPLACES 022410616
10	515447360	BATTERY CORD (-)	1	
11	955300500	TERMINAL COVER (+)	1	
12	955300510	TERMINAL COVER (-)	1	
13	954406400	CLAMP 1047-40	1	
14	959021812	SPIRAL TUBE 6D-800L	1	
15	959021811	SPIRAL TUBE 6D-400L	1	
16	507010110	CLAMP TC-200	3	
17	506010070	CLAMP TC-150	10	
18	601303150	RUBBER PLATE 160-226-1T	1	
27	955405910	MICRO-SWITCH	1	
28	955405450	COVER, MICRO-SWITCH	1	
31	515337110	HOLDER, MICRO-SWITCH	1	
32	515449230	PLATE, MICRO-SWITCH	1	
33	012210020	BOLT 10X20 T.....	6.....	REPLACES 001221020
34	031110160	WASHER, FLAT M10	2	
35	030210250	WASHER, LOCK M10	6	
36	001200430	BOLT 4X30	2	
37	031104080	WASHER, FLAT M4	2	
38	022710405	NYLON NUT M4	2	
46	0105050616	BOLT 6X15 T.....	2.....	REPLACES 001220615
47	030206150	WASHER, LOCK M6	2	
48	952404470	WASHER, FLAT M6.....	2.....	REPLACES 031106100
49	515450380	WIRE HARNESS	1	
52	516335040	BASE BATTERY	1	
53	515448530	BATTERY CORD (+) 1100L	1	
54	955300480	BATTERY TERMINAL (+)	1	
55	955300490	BATTERY TERMINAL (-)	1	
70	515453230	READ CORD (M-SWITCH) 550L-2	1	
80	10519878570	HARNESS (C), WIRE	1	

# CLUTCH (VIBRATION) ASSY.

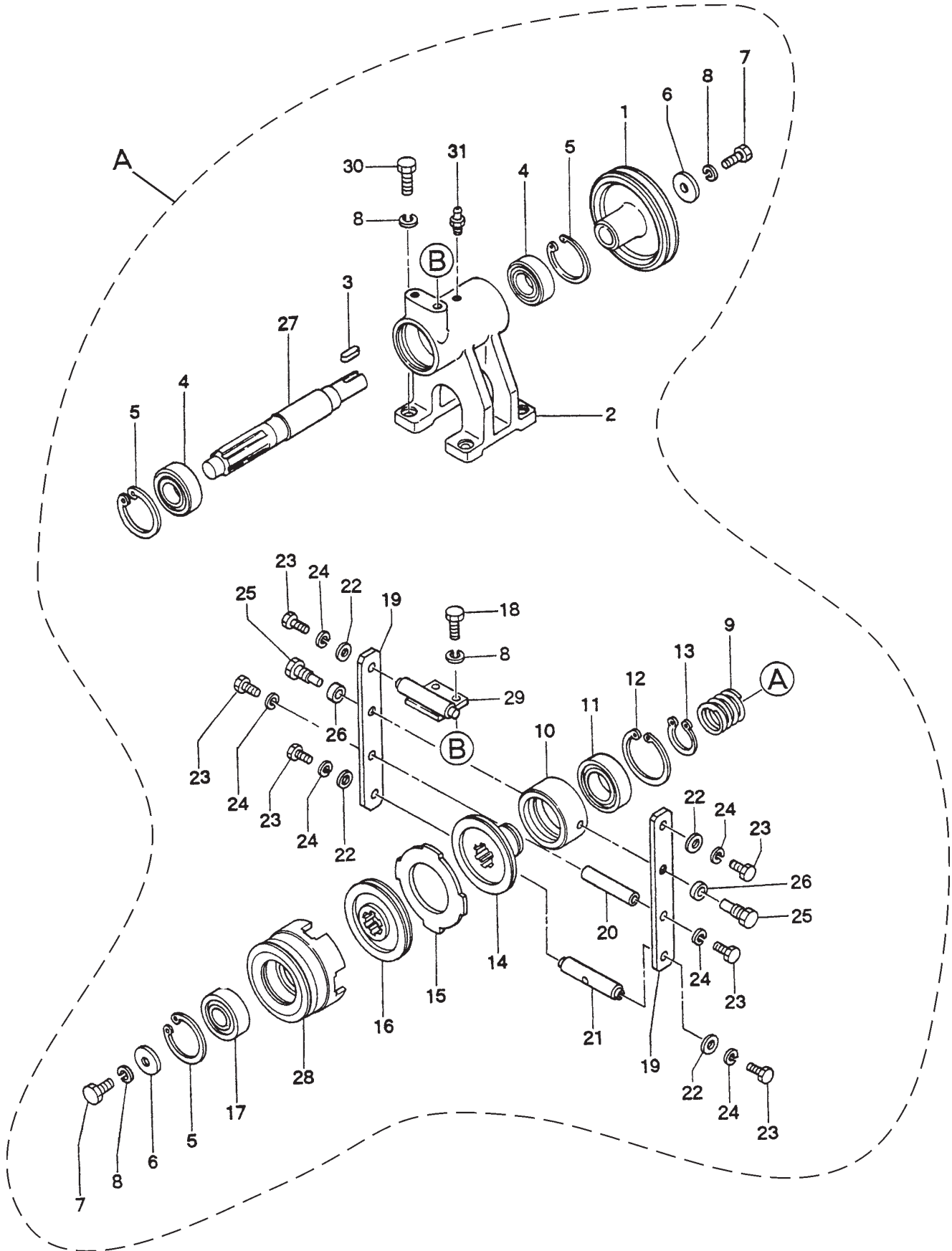

## CLUTCH (VIBRATION) ASSY.

<u>NO.</u>	<u>PART NO.</u>	<u>PART NAME</u>	<u>QTY.</u>	<u>REMARKS</u>
A	515910010	CLUTCH ASSY (VIB.) .....	1.....	INCLUDES ITEMS W/ *
1*	515447070	COUNTER PULLEY 130D-3V1	1	
2*	515212980	COUNTER BRACKET	1	
3*	951403020	KEY 7X7X26	1	
4*	043006206	BEARING 6206V	2	
5*	080100620	STOP RING R-62	3	
6*	952402470	COLLAR 11X36X6	2	
7*	012010030	BOLT 10X30 T.....	2.....	REPLACES 001221030
8*	030210250	WASHER, LOCK M10	8	
9*	509434770	CLUTCH SPRING	1	
10*	509434780	RELEASE COLLAR 62X78X40	1	
11*	044006008	BEARING 6008VV	1	
12*	080100680	STOP RING R-68	1	
13*	080200400	STOP RING S-40	1	
14*	515447080	PRESSURE PLATE	1	
15*	515447090	INSIDE PLATE	1	
16*	515447100	DISC PLATE	1	
17*	044006305	BEARING 6305VV	1	
18*	012210020	BOLT 10X20 T.....	2.....	REPLACES 001221020
19*	509324690	RELEASE FORK	2	
20*	509434850	STUD BAR 18D X80L	1	
21*	509434860	LOCK, WIRE	1	
22*	952401690	WASHER 7173	4	
23*	010505506	BOLT 6X15 T.....	6.....	REPLACES 001220615
24*	030206150	WASHER, LOCK M6	6	
25*	509434870	FORK PIN	2	
26*	509434880	COLLAR, FORK PIN 12.5X20X5	2	
27*	515334200	COUNTER SHAFT	1	
28*	515334210	CLUTCH PULLEY 113D-A2	1	
29*	509434840	BRACKET, RELEASE FORK	1	
30*	012010030	BOLT 10X30 T.....	4.....	REPLACES 001221030
31*	505015060	GREASE FITTING A-PT1/8.....	1.....	REPLACES 301010100





## VIBRATOR ASSY.

<u>NO.</u>	<u>PART NO.</u>	<u>PART NAME</u>	<u>QTY.</u>	<u>REMARKS</u>
1	515113090	VIBRATING CASE	1	
2	515334111	ROTARY SHAFT, DRIVE	1	
3	515334121	ROTARY SHAFT, DRIVEN	1	
6	040406308	BEARING 6308C4	4	
7	501011020	GEAR SPACER	2	
8	501011001	GEAR 38-2P	1	
8-1	501011002	GEAR 38-1P	1	
9	951400080	KEY 10X8X17 .....	2.....	REPLACES 951400081
10	952400900	WASHER 13446	3	
11	001221225	BOLT 12X25 T	4	
12	030212300	WASHER, LOCK M12	4	
13	953405570	SEAL CAP SC- 90-10	3	
14	060206020	OIL SEAL SC- 659013	1	
15	080100900	STOP RING R-90	2	
16	515447040	PULLEY 86D-A2	1	
17	951400090	KEY 10X8X33	1	
18	952401590	WASHER 13X50X6	1	
19	070100381	V-BELT A- 38 RED	2	
20	515334140	COVER, GEAR	1	
21	515334150	PACKING, COVER	1	
22	014208020	BOLT 8X20 T.....	8.....	REPLACES 001220820
23	030208200	WASHER, LOCK M8	8	
24	894230	PLUG PT1/4.....	2.....	REPLACES 505015380
25	001221425	BOLT 14X25 T	10	
27	031108160	WASHER, FLAT M8	8	



## UPPER CONTROL ARM ASSY.

<u>NO.</u>	<u>PART NO.</u>	<u>PART NAME</u>	<u>QTY.</u>	<u>REMARKS</u>
8	959403840	BAR GRIP, I.D. 12MM	2	
9	953402930	COPPER PACKING 19X30X1	3	
10	509010130	BUSHING MB1825DU	3	
11	952405700	WASHER 19X49X0.6	2	
12	032118300	CONICAL SPRING WASHER M18	2	
13	020418110	NUT M18, H=11	2	
14	515447410	LEVER JOINT, TRAVELING	1	
15	011208030	BOLT 8X30 T.....	3	REPLACES 001220830
16	030208200	WASHER, LOCK M8	3	
17	02108060	NUT M8.....	5	REPLACES 020308060
18	501011162	ROD END PR6-209	2	
19	011206020	BOLT 6X20 T.....	1	REPLACES 001220620
20	952404470	WASHER 6.5X15X1.6	4	
21	030206150	WASHER, LOCK M6	14	
22	515342360	CABLE ASSY	1	
38	031108160	WASHER, FLAT M8		
40	509326970	SHAFT, LEVER	1	
41	080200180	STOP RING S-18	1	
42	509436911	LEVER, VIBRATION	1	
43	011208035	BOLT 8X35 T.....	1	REPLACES 001220835
44	515334240	CABLE ASSY., VIBRATION	1	
45	959404760	CLEVIS 8D X44	1	
46	959404370	PIN 8X22	1	
47	025910080	SNAP PIN /SSP-8	1	
49	0105050616	BOLT 6X15 T.....	12	REPLACES 001220615



## UPPER CONTROL ARM ASSY.

### CONTINUED

<u>NO.</u>	<u>PART NO.</u>	<u>PART NAME</u>	<u>QTY.</u>	<u>REMARKS</u>
53	951401431	KEY 5X5X8	1	
55	952404790	WASHER 13306	1	
56	032212250	CONICAL SPRING WASHER M12	2	
57	0039312000	NUT M12.....	3.....	REPLACES 020312100
59	515334820	ROD	1	
60	509010140	BUSHING MB1625DU	2	
61	515447720	DISC PLATE, DEAD-MAN	1	
62	030212300	WASHER, LOCK M12	1	
63	509436980	SPRING, DEAD-MAN	1	
64	509436990	PROTECTOR, DEAD-MAN	1	
65	507010110	CLAMP TC-200	2	
66	509436960	ROD STOPPER, DEAD-MAN	1	
67	014206010	SOCKET HEAD SCREW 6X6 T .....	2.....	REPLACES 099206006
70	959405920	KNOB 44D-78L	1	
92	515336490	TRAVELING LEVER 260L	1	
93	515212950	LEVER SUPPORT, VIB. E/G	1	
94	515334460	LEVER COVER, VIB.	1	
95	515336500	LEVER, E/G 133L	1	
96	509326320	GUIDE, WIRE (E/G)	1	
97	509436950	COVER, HANDLE BOX	1	
100	011006010	BOLT 6X10 T.....	4.....	REPLACES 001220610
101	030206150	WASHER, LOCK M6	4	
180	517338590	COVER (FOR KEY SWITCH)	1	
201	956100024	THROTTLE WIRE	1	

# LOWER CONTROL ARM ASSY.

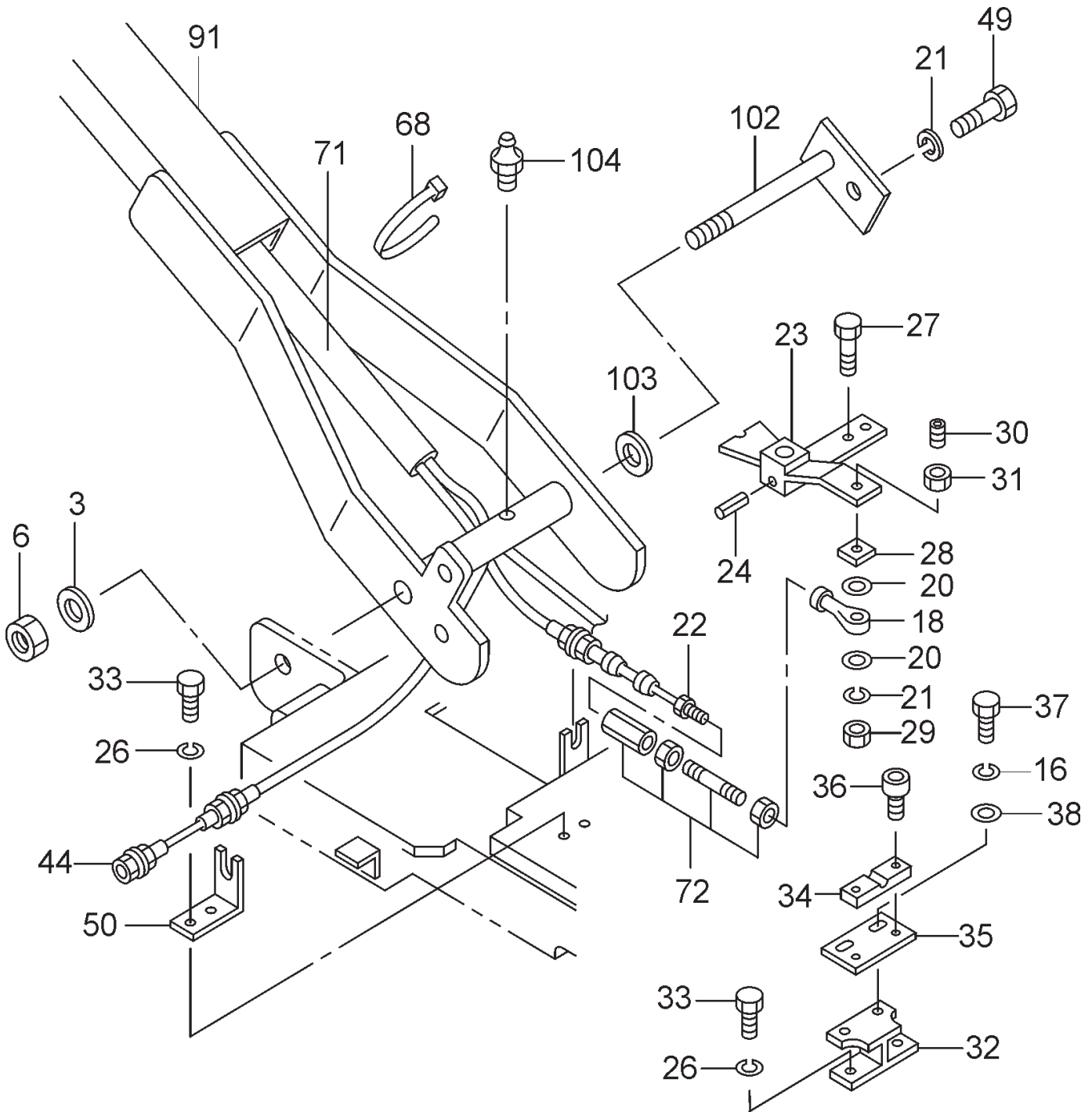

## LOWER CONTROL ARM ASSY.

<u>NO.</u>	<u>PART NO.</u>	<u>PART NAME</u>	<u>QTY.</u>	<u>REMARKS</u>
3	031120320	WASHER, FLAT M20	1	
6	022522017	LOCK NUT U-M20	2	
16	030208200	WASHER, LOCK M8	3	
18	501011162	ROD END PR6-209	2	
20	952404470	WASHER 6.5X15X1.6	4	
21	030206150	WASHER, LOCK M6	14	
22	515342360	CABLE ASSY 1700L	1	
23	515335780	LEVER (PV10), E- START	1	
24	025406032	SPRING PIN 6X32	1	
26	030210250	WASHER, LOCK M10	4	
27	001220635	BOLT 6X35 T	1	
28	515450560	SPACER (PV10)	1	
29	022710607	NYLON NUT M6	1	
30	505015150	SPRING PLUNGER	1	
31	020116130	NUT M16, H=10.....	1.....	REPLACES 020416100
32	509321160	GUIDE HOLDER	1	
33	012210020	BOLT 10X20 T.....	4.....	REPLACES 001221020
34	515448170	GUIDE	1	
35	515448180	SLIDE PLATE	1	
36	014206015	SOCKET HEAD BOLT 6X15 T.....	2.....	REPLACES 001520615
37	011008015	BOLT 8X15 T.....	2.....	REPLACES 001220815
38	031108160	WASHER, FLAT M8	3	
44	515334240	CABLE ASSY (VIB.)	1	
49	001220615	BOLT 6X15 T	12	
50	515447180	CABLE SUPPORT, VIB.	1	
68	506010070	CLAMP TC-150	8	
71	959021911	TUBE 25D-850L	1	
72	501910010	TURN BUCKLE ASSY.	1	
91	515119120	HANDLE (PIN TYPE)	1	
102	515454970	HANDLE PIN	1	
103	515454980	COLLAR (HANDLE)	1	
104	351010050	GREASE FITTING A-MT6X1	1	



# YANMAR L100V1 — CYLINDER BLOCK ASSY

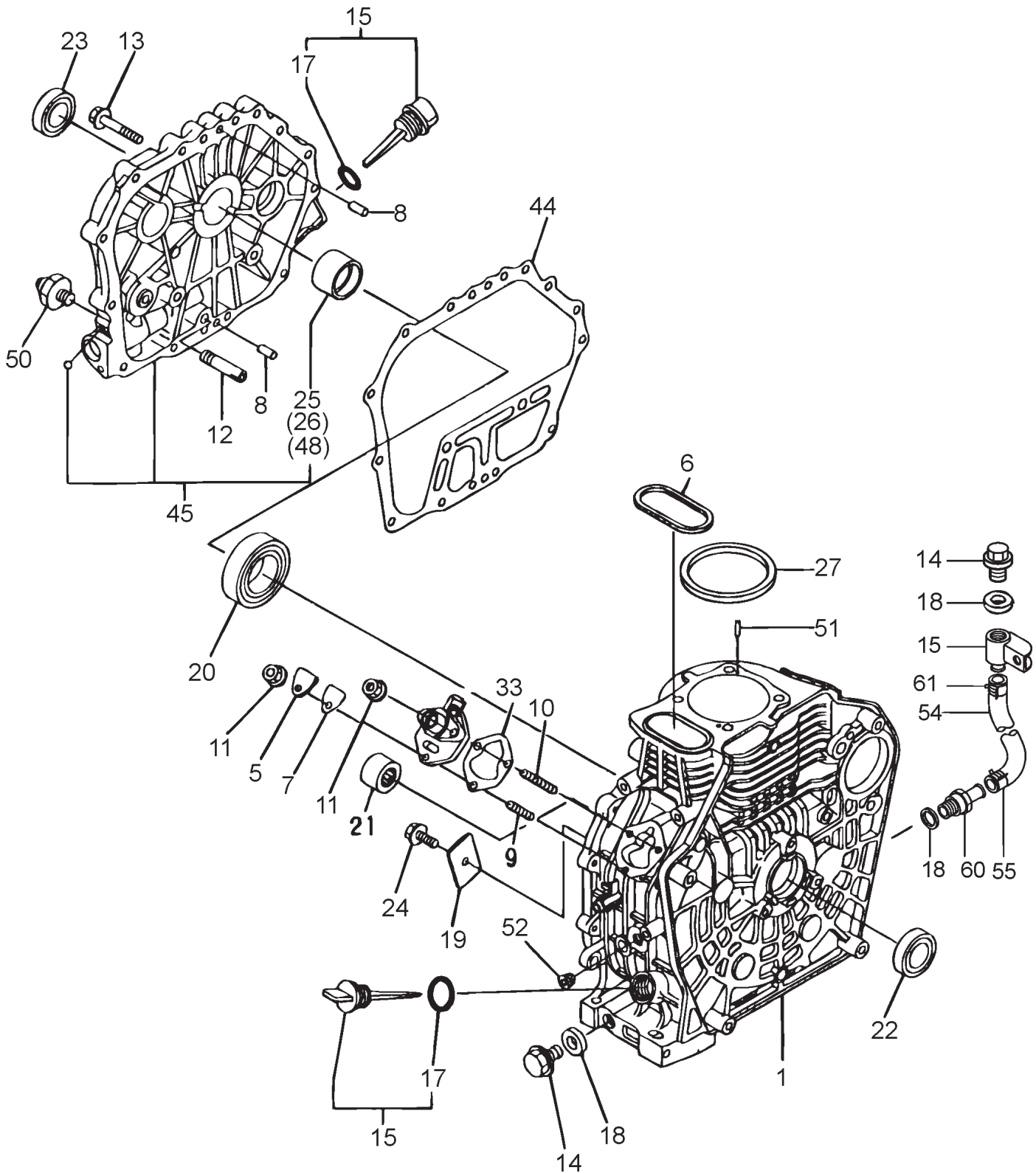

## YANMAR L100V1 — CYLINDER BLOCK ASSY

<u>NO.</u>	<u>PART NO.</u>	<u>PART NAME</u>	<u>QTY.</u>	<u>REMARKS</u>
1	11431001020	BLOCK ASSY. CYLINDER	1	
5	11429901830	COVER, PUMP	1	
6	11469901380	O-RING	1	
7	11425001841	GASKET	1	
8%	11429901600	PIN 8X12	2	
9	26226060182	STUD M 6X18 PLATED	1	
10	26226060222	STUD M 6X22 PLATED	2	
11	26366060002	NUT M6	3	
12%	11429935150	PIPE, L.O. INLET	1	
13	26106080352	BOLT M 8X35 PLATED	16	
14	10542501690	PLUG M16	2	
15	11469901760	CAP, W/LUB.OIL GAUGE .....	2	INCLUDES ITEMS W/ #
17#	24311000180	O-RING P-18.0	2	
18	22190160002	SEAL WASHER 16S	2	
19	11429902030	RETAINER	1	
20	11465002150	BALL BEARING	1	
21	24162152220	NEEDLE 152220	1	
22	24423355008	SEAL, OIL	1	
23	22423355008	SEAL, OIL	1	
24	26106080122	BOLT M 8 X 12 PLATED	1	
25	11465002200	MAIN BEARING US = 0.25	1	
26	11465002210	MAIN BEARING US = 0.50	1	
27	11469501330	GASKET ASSY, CYLINDER HEAD	1	
33	11429901800	SHIM SET	1	
44	11469901410	GASKET CRANKCASE	1	
45	11431001450	COVER D, CRANKCASE.....	1	INCLUDES ITEMS W/ %
48%	11465002100	BEARING, MAIN (STD)	1	
50	12125239450	SENDER, OIL PRESSURE	1	
51	22312040080	PIN 4 X 8 STRAIGHT	2	
52	23875020000	PLUG PT 1/4, STEEL	1	
54	11498401940	PIPE, DRAIN	1	
55	23000019000	CLAMP 19	2	
60	11498508350	NIPPLE, DRAIN	1	
61	11435239400	JOINT, DRAIN	1	

# YANMAR L100V1— CYLINDER HEAD AND COVER ASSY

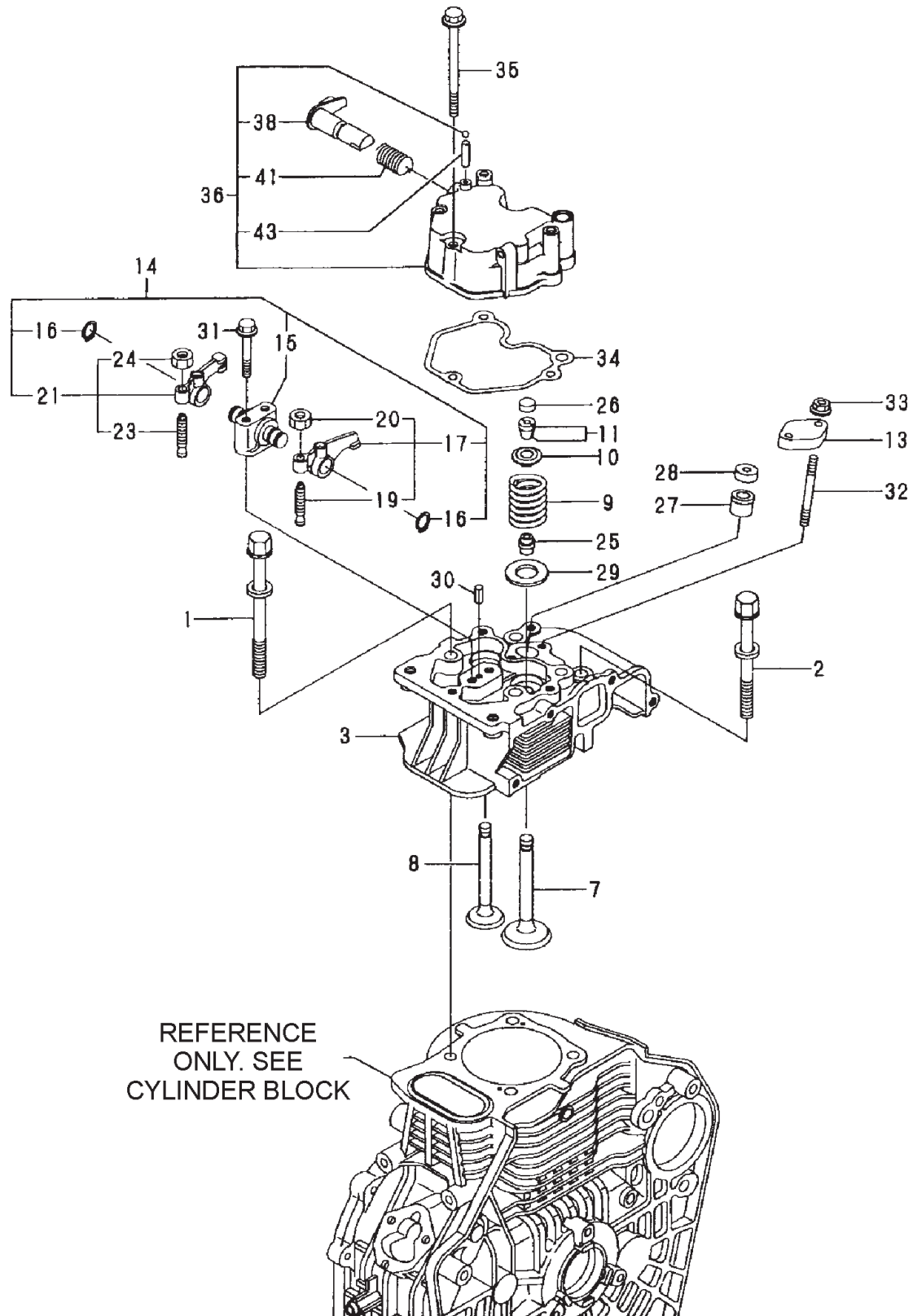

# YANMAR L100V1— CYLINDER HEAD AND COVER ASSY

<u>NO.</u>	<u>PART NO.</u>	<u>PART NAME</u>	<u>QTY.</u>	<u>REMARKS</u>
1	11431001200	BOLT, CYLINDER HEAD A	2	
2	11431001210	BOLT, CYLINDER HEAD B	2	
3	11431011020	HEAD ASSY CYLINDER	1	
7	11431011100	VALVE, INTAKE	1	
8	11431011110	VALVE, EXHAUST	1	
9	11431011120	SPRING, VALVE	2	
10	11431011180	RETAINER, SPRING	2	
11	11431011930	COTTER ASSY	2	
13	11421011900	RETAINER, NOZZLE	1	
14	11431011250	SUPPORT, ASSY ROCKER .....	1	INCLUDES ITEMS W/ %
15%	11431011260	SUPPORT, ROCKER ARM	1	
16%	11431011280	C-TYPE RETAINING PIN	2	
17%	11431011650	ARM ASSY. INTAKE .....	1	INCLUDES ITEMS W/ >
19>	11429911240	SCREW, ADJUSTING	1	
20>	26856060002	LOCK NUT 6	1	
21%	11431011660	ARM ASSY., EXHAUST .....	1	INCLUDES ITEMS W/ *
23*	11429911240	SCREW, ADJUSTING	1	
24*	26856060002	LOCK NUT 6	1	
25	11465011340	SEAL, VALVE STEM	2	
26	10421111370	CAP, VALVE	2	
27	11477111461	GASKET, NOZZLE	1	
28	11429511470	SPACER, NOZZLE	1	
29	11465011600	WASHER	2	
30	22351040008	SPRING PIN 4 X 8	1	
31	26106080502	BOLT M 8 X 50 PLATED	2	
32	26226060552	STUD M 6 X 55 PLATED	2	
33	26366060002	NUT M 6	2	
34	11431011310	GASKET, BONNET	1	
35	26106060652	BOLT M 6 X 65 PLATED	3	
36	11431011950	COVER ASSY. HEAD .....	1	INCLUDES ITEMS W/ #
38#	11421003590	SHAFT ASSY., DECOMP.	1	
41#	11429903640	SPRING, DECOMP.	1	
43#	22312030160	PARALLEL PIN 3 X 16	1	

# YANMAR L100V1 — AIR CLEANER AND MUFFLER ASSY

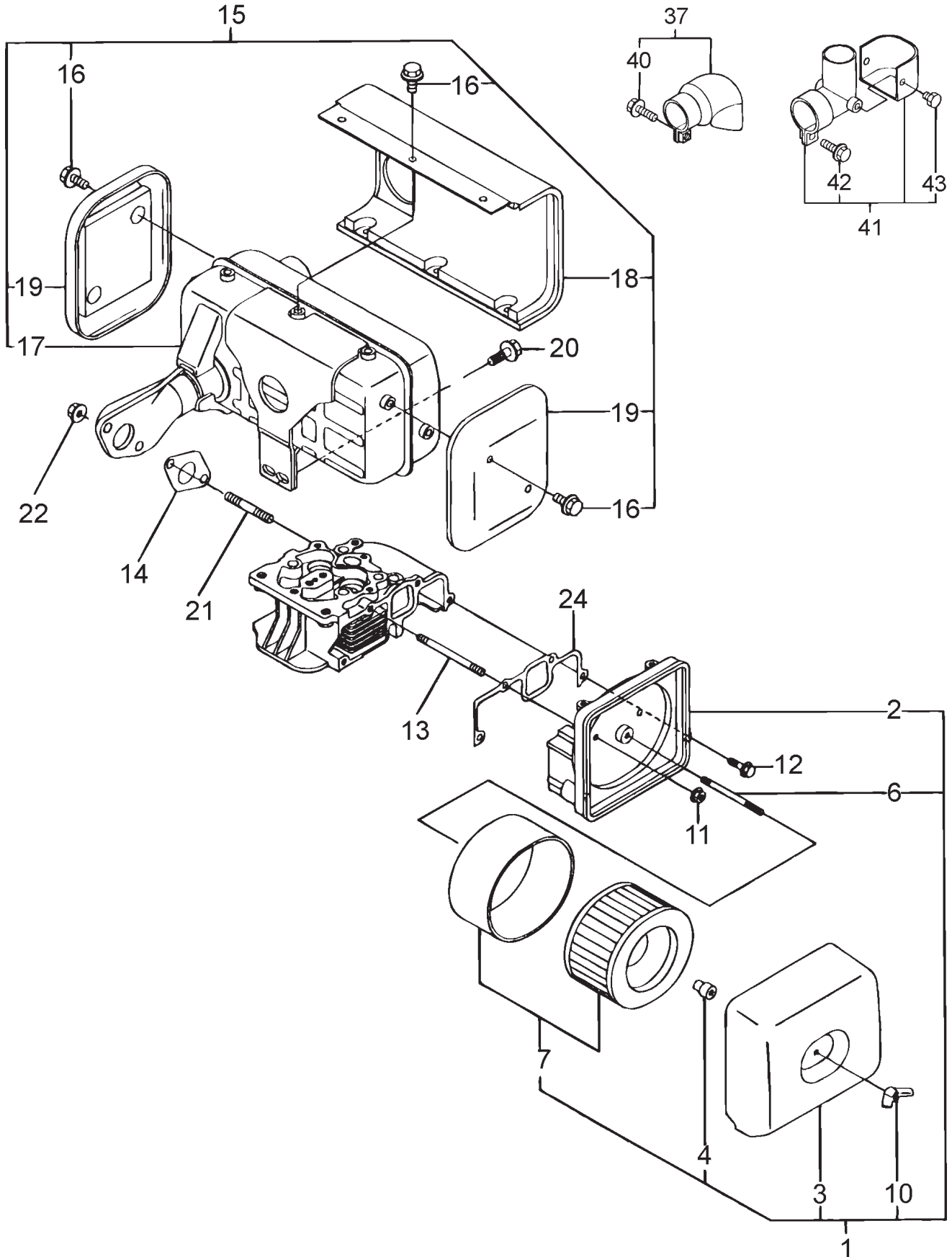

# YANMAR L100V1 — AIR CLEANER AND MUFFLER ASSY

<b>NO.</b>	<b>PART NO.</b>	<b>PART NAME</b>	<b>QTY.</b>	<b>REMARKS</b>
1	11431012510	AIR CLEANER ASSY.....	1.....	INCLUDES ITEMS W/ *
2*	11431012020	BODY, AIR CLEANER	1	
3*	11421012520	COVER, AIR CLEANER	1	
4*	11421012560	NUT, WING		
6*	11421012580	STUD BOLT	1	
7*	11421012590	ELEMENT ASSY	1	
10*	11421012600	KNOCKING KNOB	1	
11	11429912300	NUT, U	3	
12	26106060402	BOLT, M 6 X 40 PLATED	1	
13	26226060352	STUD, M 6 X 358 PLATED	3	
14	11431013200	GASKET, MUFFLER	1	
15	11469913551	MUFFLER ASSY .....	1.....	INCLUDES ITEMS W/ #
16#	11469913720	BOLT M6 FLANGE	10	
17#	11469913561	MUFFLER	1	
18#	11469913700	COVER A, MUFFLER	1	
19#	11469913710	COVER B, MUFFLER	2	
20	26106080202	BOLT, M 8 X 20 PLATED	2	
21	26216080182	STUD, M 8 X 18 PLATED	2	
22	26366080002	NUT, M 8	2	
24	11431012210	GASKET, AIR CLEANER	1	
37	10519813622	EXTENSION, SILENCER .....	1.....	INCLUDES ITEM W/ +
40+	10509813990	BOLT	1	
41	11498513701	PIPE, SILENCER.....	1.....	INCLUDES ITEMS W/ %
42%	10509813990	BOLT	1	
43%	26113060082	BOLT, M 6 X8	2	

# YANMAR L100V1 — CRANKSHAFT, PISTON, CAMSHAFT ASSY

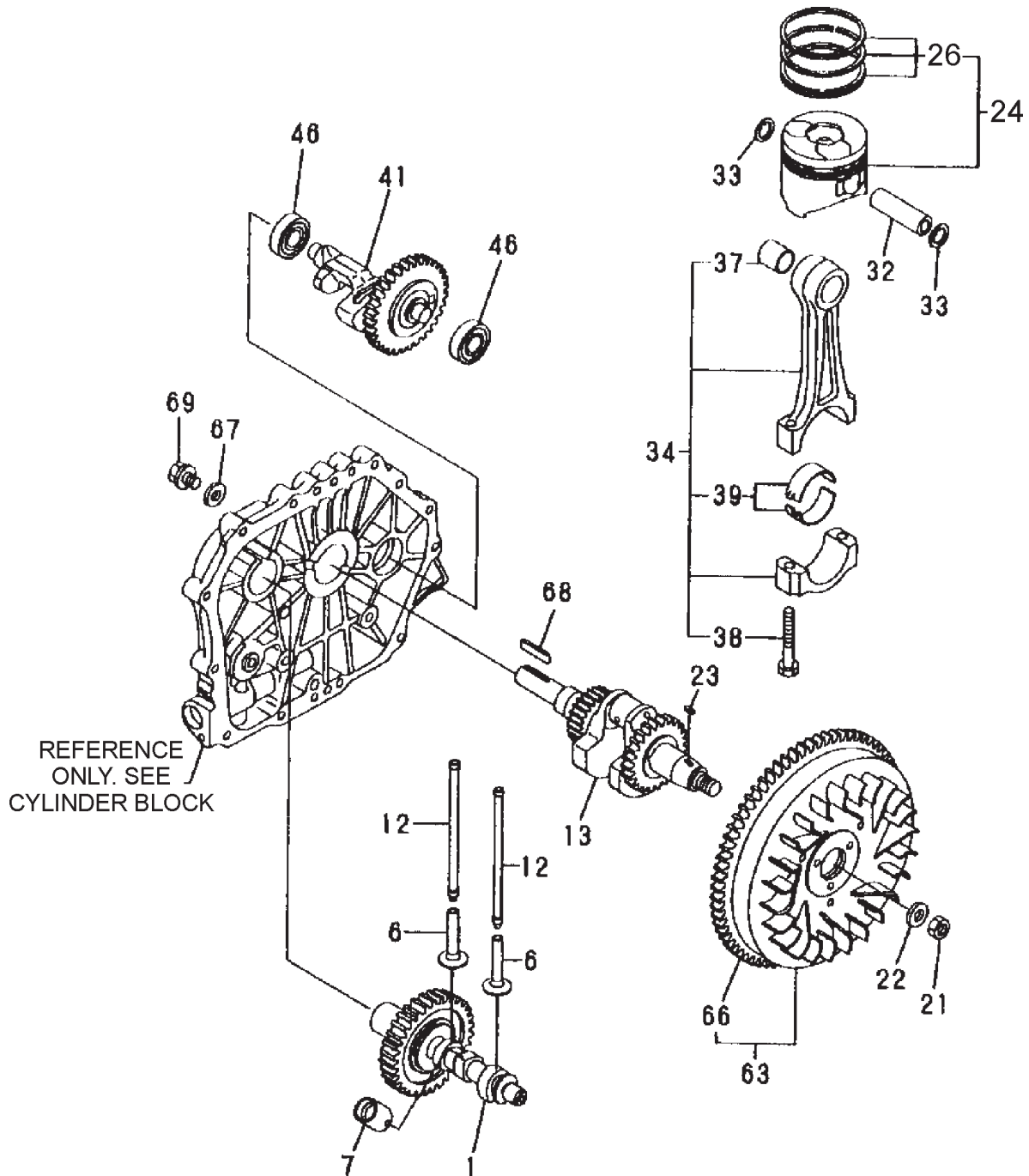



# YANMAR L100V1 — CRANKSHAFT, PISTON, CAMSHAFT ASSY

<u>NO.</u>	<u>PART NO.</u>	<u>PART NAME</u>	<u>QTY.</u>	<u>REMARKS</u>
1	71431014580	CAMSHAFT ASSY., D	1	
6	11431014200	TAPPET	2	
7	11421014300	TAPPET ASSY, ROLLER	1	
12	11431014400	ROD ASSY, PUSH	2	
13	71431021740	CRANKSHAFT ASSY.	1	
21	11469921220	NUT	1	
22	11465021551	WASHER, FLYWHEEL	1	
23	22512050140	KEY, 5 X 14	1	
24	71431022720	PISTON, W/ RINGS (STD) .....	1	INCLUDES ITEMS W/ #
24	71431022620	PISTON, W/ RINGS (OS = 0.25) .....	1	INCLUDES ITEMS W/ %
24	71431022580	PISTON, W/ RINGS (OS = 0.5) .....	1	INCLUDES ITEMS W/ +
26#	71497022500	RING SET, PISTON (STD)	1	
26%	71497022500	RING SET, PISTON (OS = 0.25)	1	
26+	71497022500	RING SET, PISTON (OS = 0.5)	1	
32	11469922300	PIN, PISTON D=23	1	
33	12979222400	CIRCLIP 23	2	
34	71431023700	ROD ASSY., CONNECTING.....	1	INCLUDES ITEMS W/ \$
37\$	12406023910	BUSH, PISTON PIN	1	
38\$	11981023200	BOLT, CONNECTING ROD	2	
39\$	71465023600	BEARING, PIN (STD)	1	
39	71465023610	BEARING, PIN (OS = 0.25)	1	
39	71465023620	BEARING, PIN (OS = 0.5)	1	
41	71431028510	SHAFT ASSY., BALANCER	1	
46	24101063040	BALL BEARING	1	
63	11469921590	FLYWHEEL, ASSY.....	1	INCLUDES ITEMS W/ >
66>	11466221601	GEAR, RING	1	
67	16031014550	WASHER	1	
68	22512070360	KEY 7 X 36	1	
69	26106080202	BOLT M 8 X 20 PLATED	1	

# YANMAR L100V1 — LUB. OIL PUMP AND GOVERNOR ASSY.

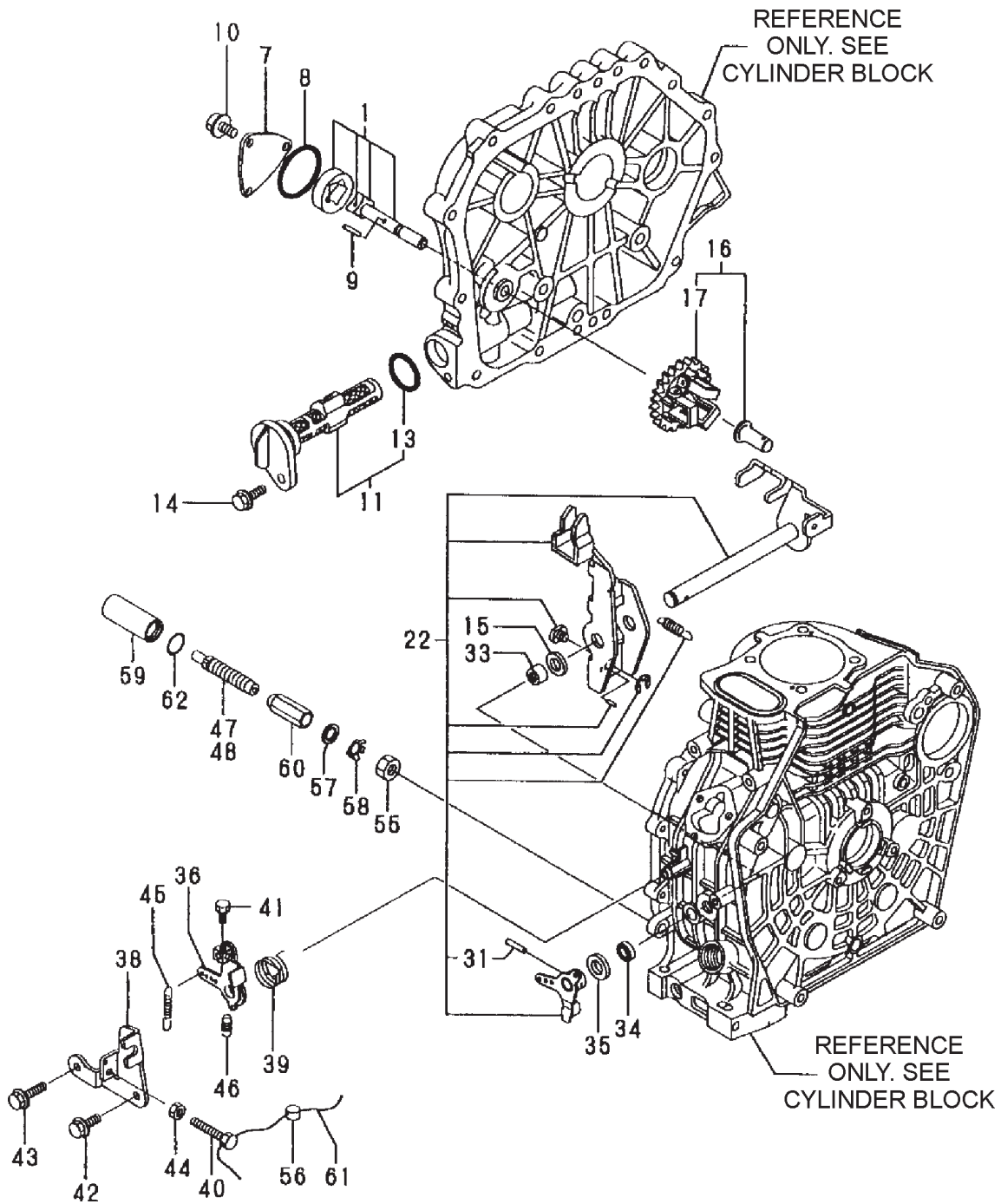

# YANMAR L100V1 — LUB. OIL PUMP AND GOVERNOR ASSY.

<u>NO.</u>	<u>PART NO.</u>	<u>PART NAME</u>	<u>QTY.</u>	<u>REMARKS</u>
1	11465032010	PUMP ASSY. LUB. OIL	1	
7	11429932070	COVER, LUB. OIL PUMP	1	
8	10333832570	O-RING	1	
9	22312030160	PARALLEL PIN 3 X 16	1	
10	26106060122	BOLT, M 6 X12, PLATED	3	
11	11429935110	FILTER, LUB. OIL ASSY.....	1	INCLUDES ITEMS W/ #
13#	24341000224	O-RING 1A S-22.4	1	
14	26106060162	BOLT M 6 X 16 PLATED	1	
15*	11429961190	WASHER, GOVERNOR	1	
16	71421061700	GOVERNOR ASSY.....	1	INCLUDES ITEM W/ %
17%	11421061290	WEIGHT, GOVERNOR ASSY	1	
22	11431161500	LEVER ASSY., GOVERNOR .....	1	INCLUDES ITEMS W/ *
31*	22322030200	TAPER PIN 3 X 20	1	
33*	11477061520	BEARING, NEEDLE	2	
34	11429961600	SEAL, OIL	1	
35	11477061610	WASHER, THRUST	1	
36	11425266051	HANDLE, REGULATOR	1	
38	18336066110	BRACKET, REGULATOR	1	
39	11429966250	SPRING, RETURN	1	
40	11429966440	BOLT, ADJUSTING	1	
41	10522566990	SCREW	1	
42	26106060142	BOLT M 6 X 14 PLATED	1	
43	26106060202	BOLT M 6 X 20 PLATED	1	
44	26757060002	NUT 6	1	
45	11431066010	SPRING, REGULATOR	1	
46	11429966200	SPRING, RETURN	1	
48	11425066550	CONTROLLER ASSY.	1	
55	26776100002	LOCK NUT M10 PLATED	1	
56	11478061090	LEAD	1	
57	11477161800	WASHER	1	
58	11477161820	PLATE	1	
59	11477161900	PROTECTOR	1	
60	11477161931	NUT	1	
61	22451060000	WIRE 0.6	1	
62	24311000125	O-RING 1A P-12.5	1	

# YANMAR L100V1 — COOLING AND STARTING DEVICE ASSY.

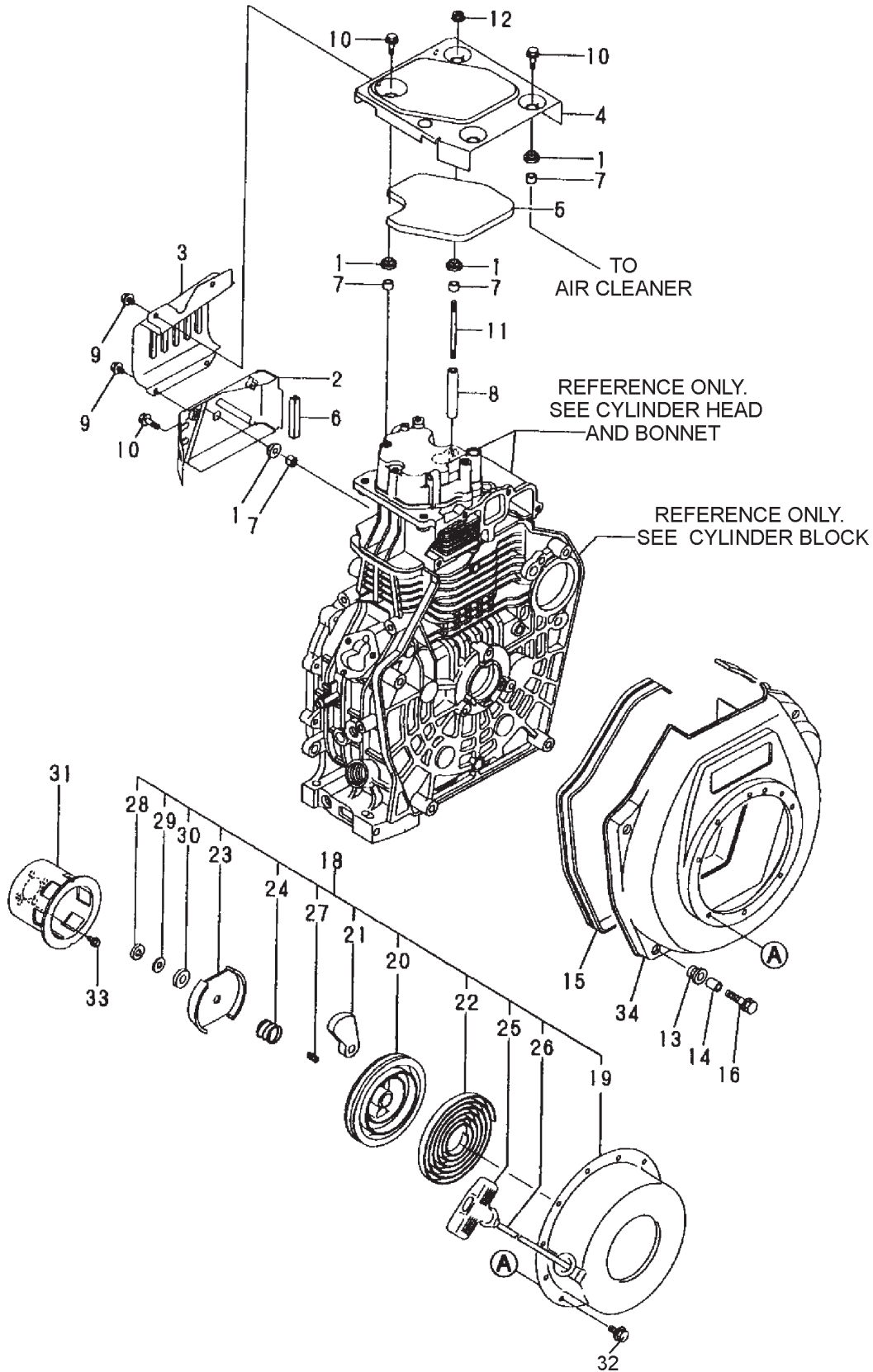

# YANMAR L100V1 — COOLING AND STARTING DEVICE ASSY.

<u>NO.</u>	<u>PART NO.</u>	<u>PART NAME</u>	<u>QTY.</u>	<u>REMARKS</u>
1	11429945220	GROMMET, TANK	5	
2	11431045260	COVER B, SIDE	1	
3	11431045270	COVER A, SIDE	1	
4	11431045300	COVER, TOP (BLACK)	1	
5	11431045310	DAMPER	1	
6	11439945320	RUBBER, SEAL	1	
7	11435045340	COLLAR, CYL. COVER	5	
8	11431045350	SPACER, TOP COVER	1	
9	26106060082	BOLT M 6 X8 PLATED	4	
10	26106060202	BOLT M 6 X20 PLATED	4	
11	26226060752	STUD M6 X75	1	
12	26366060002	NUT M6	1	
13	11429945300	RUBBER, CUSHION	4	
14	11429945310	COLLAR, FAN CASE	4	
15	11469945330	SEAL, FAN CASE	1	
16	11429945350	BOLT, FAN CASE	4	
18	11469976251	RECOIL ASSY.....	1	INCLUDES ITEMS W/ *
19*	11469976510	CASE, STARTER	1	
20*	11466976520	REEL, RECOIL	1	
21*	11469976531	RATCHET	2	
22*	11469976540	SPRING, SPIRAL	1	
23*	11469976551	GUIDE, RATCHET	1	
24*	11469976560	SPRING, FRICTION	1	
25*	11469976620	KNOB, STARTER	1	
26*	11469976630	ROPE, RECOIL STARTER	1	
27*	11469976650	SPRING, RETURN	2	
28*	11469976660	RETAINING RING	1	
29*	11469976670	WASHER	1	
30*	11469976680	WASHER IN NYLON	1	
31	11469976592	PULLEY, STARTER	1	
32	26106060082	BOLT M 6 X 8 PLATED	4	
33	26106060122	BOLT M 6 X 12 PLATED	3	
34	11431045100	FAN CASE (SILVER)	1	

# YANMAR L100V1 — FUEL INJECTION PUMP AND VALVE ASSY.

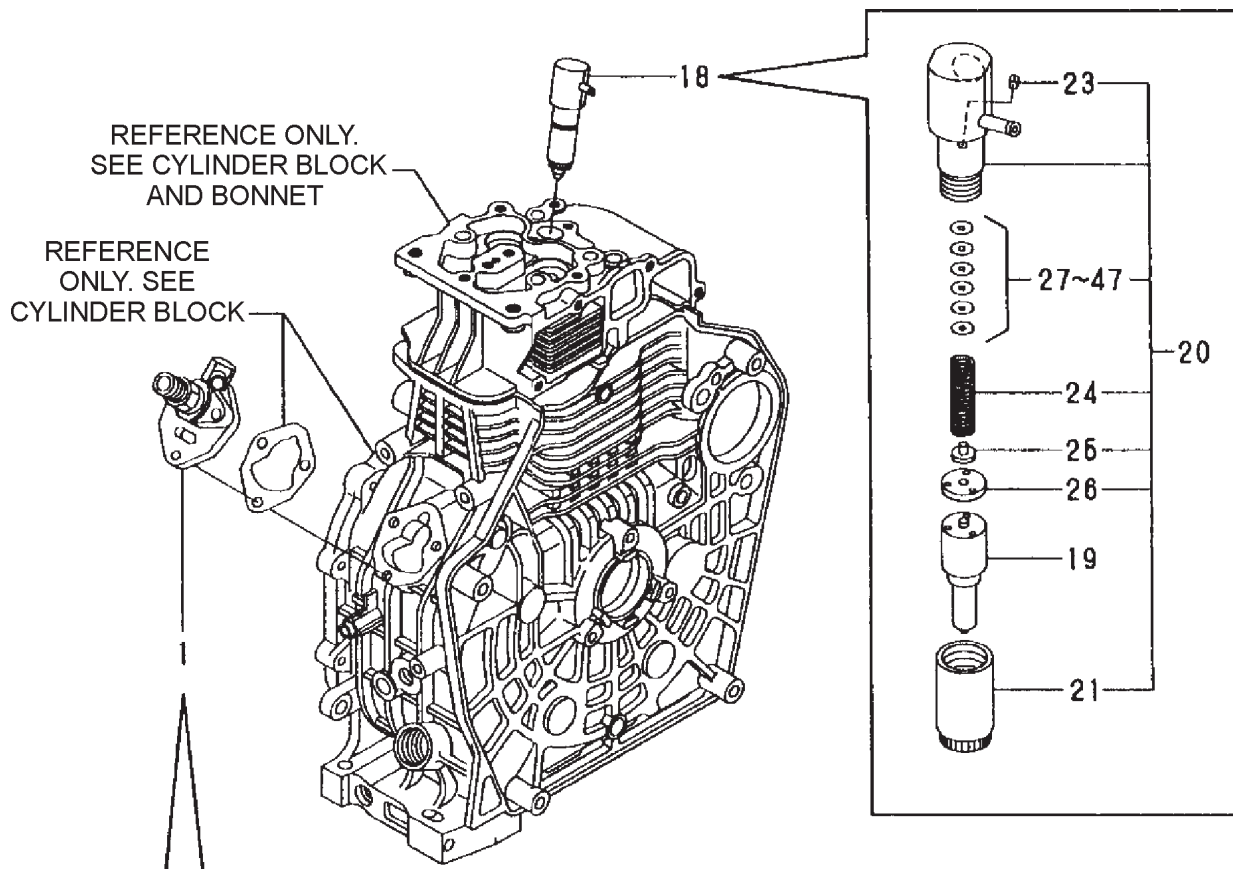

## YANMAR L100V1 — FUEL INJECTION PUMP AND VALVE ASSY.

<u>NO.</u>	<u>PART NO.</u>	<u>PART NAME</u>	<u>QTY.</u>	<u>REMARKS</u>
1	71434951400	PUMP ASSY., FUEL INJECTION	1	
18	71421053100	FUEL INJECTOR.....	1.....	INCLUDES ITEMS W/ %
19#	11421053000	NOZZLE, ASSY.	1	
20%	11487553100	HOLDER ASSY., NOZZLE.....	1.....	INCLUDES ITEMS W/ #
21#	11421053080	NUT, NOZZLE	1	
23#	11421053330	PIN	1	
24#	11421053120	SPRING, NOZZLE	1	
25#	11421053130	SEAT, SPRING	1	
26#	11421053140	SPACER ASSY, VALVE	1	
27#	11421053410	SHIM (T=1.00)	1	
28	11421053420	SHIM (T=1.05)	1	
29	11421053430	SHIM (T=1.10)	1	
30	11421053440	SHIM (T=1.15)	1	
31	11421053450	SHIM (T=1.20)	1	
32	11421053460	SHIM (T=1.25)	1	
33	11421053470	SHIM (T=1.30)	1	
34	11421053480	SHIM (T=1.35)	1	
35	11421053490	SHIM (T=1.40)	1	
36	11421053500	SHIM (T=1.45)	1	
37	11421053510	SHIM (T=1.50)	1	
38	11421053520	SHIM (T=1.55)	1	
39	11421053530	SHIM (T=1.60)	1	
40	11421053540	SHIM (T=1.65)	1	
41	11421053550	SHIM (T=1.70)	1	
42	11421053560	SHIM (T=1.75)	1	
43	11421053570	SHIM (T=1.80)	1	
44	11421053580	SHIM (T=1.85)	1	
45	11421053590	SHIM (T=1.90)	1	
46	11421053600	SHIM (T=1.95)	1	
47	11421053610	SHIM (T=2.00)	1	

# YANMAR L100V1 — FUEL TANK ASSY.

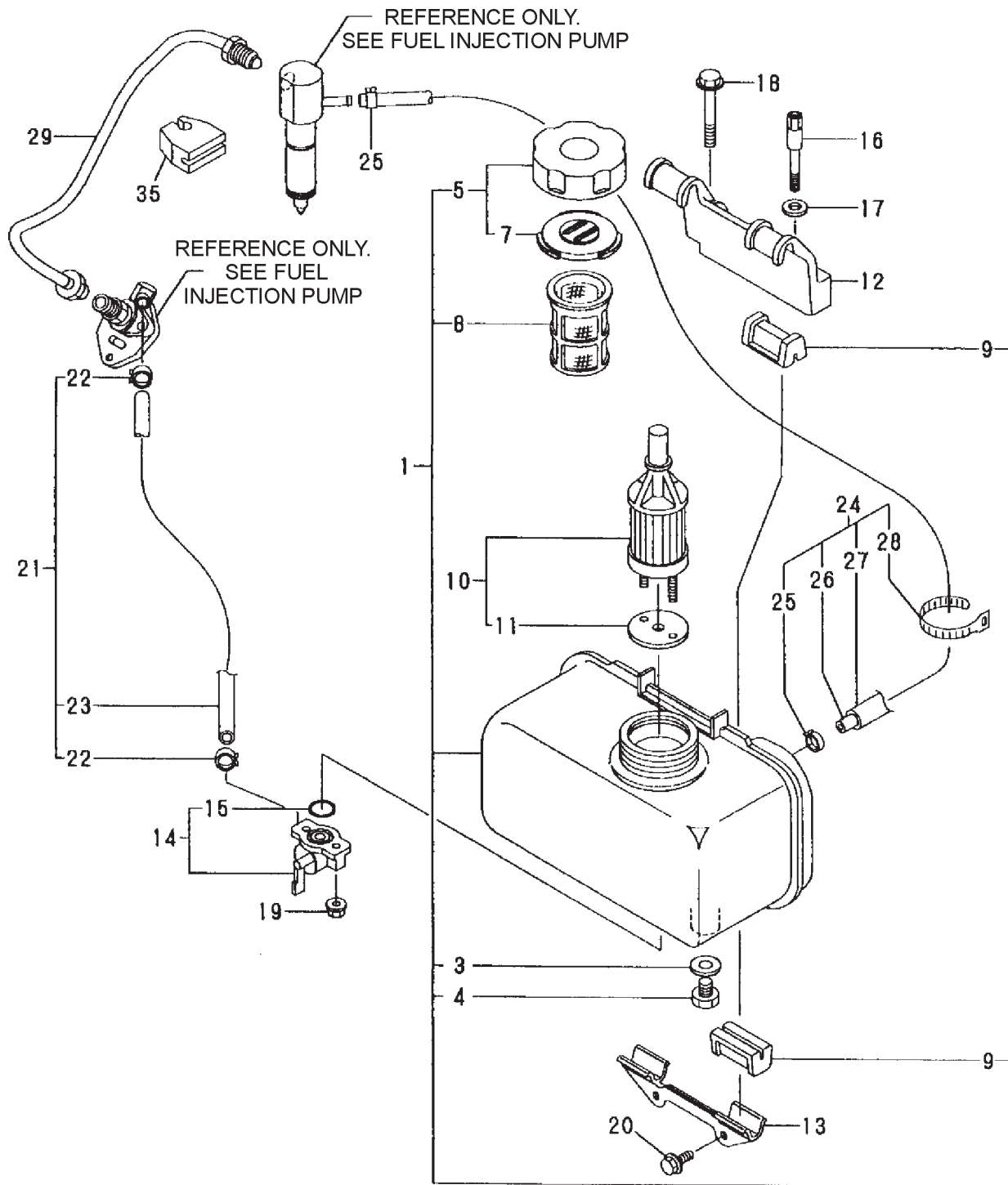



## YANMAR L100V1 — FUEL TANK ASSY.

<u>NO.</u>	<u>PART NO.</u>	<u>PART NAME</u>	<u>QTY.</u>	<u>REMARKS</u>
1	71431055700	TANK ASSY., FUEL (BLACK) .....	1.....	INCLUDES ITEMS W/ *
3*	23414080000	GASKET, ROUND	1	
4*	10530055080	PLUG, DRAIN	1	
5*	11428855041	CAP ASSY., FUEL TANK .....	1.....	INCLUDES ITEMS W/#
7*#	11428855081	VALVE	1	
8*	11429955100	FILTER, FUEL	1	
9*	11425055201	DAMPER, FUEL TANK	4	
10*	11425055121	FILTER, FUEL OIL .....	1.....	INCLUDES ITEMS W/ +
11*+	11425055130	GASKET	1	
12	11431055230	STAY B, FUEL TANK	1	
13*	11421055210	STAY A, FUEL TANK	1	
14	11425055300	FUEL COCK ASSY. ....	1.....	INCLUDES ITEMS W/ \$
15\$	24341000150	O-RING 1A S-15.0	1	
16	11456055810	BOLT, LIFTING	1	
17	22117080000	WASHER	1	
18	26106080452	BOLT M 8 X 45 PLATED	1	
19	26366060002	NUT M 6	2	
20*	26106060162	BOLT M 6 X 16 PLATED	2	
22	23080014000	CLIP, HOSE	2	
23	11478059060	PIPE, FUEL OIL	1	
24*	11431059300	PIPE ASSY, FUEL RETURN .....	1.....	INCLUDES ITEMS W/ %
25*%	12472259050	CLAMP 9	2	
26*%	11431059060	PIPE, FUEL RETURN	1	
27*%	11431059310	TUBE, PROTECTOR	1	
28*%	12175059890	CLAMP 140	1	
29	11431059800	PIPE, FUEL INJECTION	1	
35	11465059850	BRACKET, PIPE	1	

# YANMAR L100V1 — STARTING MOTOR AND DYNAMO ASSY.

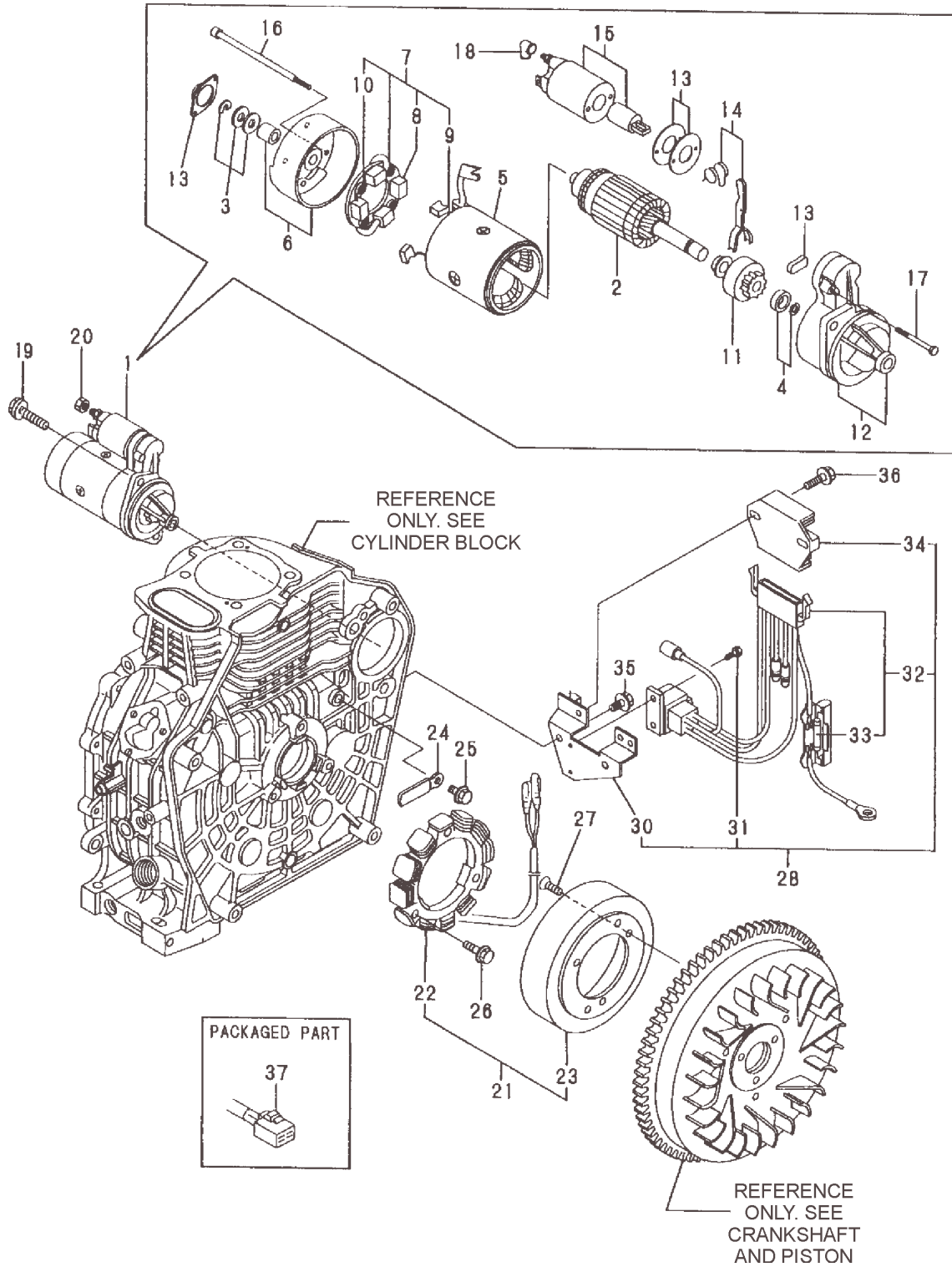

# YANMAR L100V1 — STARTING MOTOR AND DYNAMO ASSY.

NO.	PART NO.	PART NAME	QTY.	REMARKS
1	11436277011	STARTER, (HITACHI 12V).....	1.....	INCLUDES ITEMS W/ *
2*	11438177110	ARMATURE	1	
3*	X2114811000	WASHER KIT, THRUST	1	
4*	X2114715500	STOPPER SET, PINION	1	
5*	11438177130	COIL ASSY., FIELD	1	
6*	11438177140	COVER, REAR	1	
7*	11437177160	HOLDER ASSY., BRUSH .....	1.....	INCLUDES ITEMS W/ +
8*+	11437179040	BRUSH (-)	1	
9*+	11437179050	BRUSH (+)	1	
10*+	11437179060	SPRING, BRUSH	4	
11*	X211445508	PINION ASSY.	1	
12*	11438177151	HOUSING ASSY. GEAR	1	
13*	11437177170	COVER KIT, DUST	1	
14*	11437177180	SHIFT LEVER KIT	1	
15*	12969877020	SWITCH, MAGNET	1	
16*	11926077260	BOLT, THROUGH	2	
17*	11437179070	BOLT M 6 X 37	2	
18*	12125477810	COVER, TERMINAL	1	
19	26106100302	BOLT M 10 X 30 PLATED	2	
20	26716080002	NUT M8	1	
21	11439978260	DYNAMO ASSY.....	1.....	INCLUDES ITEMS W/ #
22#	11439978730	STATOR ASSY.	1	
23#	11439978740	WHEEL DYNAMO	1	
24	16026078700	CLAMP, CORD	1	
25	26106060122	BOLT M 6 X 12 PLATED	1	
26	26106060202	BOLT M 6 X 20 PLATED	3	
27	26577060152	SCREW M 6 X 15	3	
30	11434077400	BRACKET, HARNESS	1	
31	26023040102	SCREW M 4 X 10	2	
32	11435177540	HARNESS, WIRE .....	1.....	INCLUDES ITEM W/ >
33>	29411200000	FUSE 20A, CARTRIDGE	1	
34	11434077710	REGULATOR	1	
35	26106060182	BOLT M 6 X 18 PLATED	2	
36	26106060202	BOLT M 6 X 20 PLATED	2	
37	11435177520	JOINT	1	

# YANMAR L100V1 — TOOL, LABEL AND GASKET SET

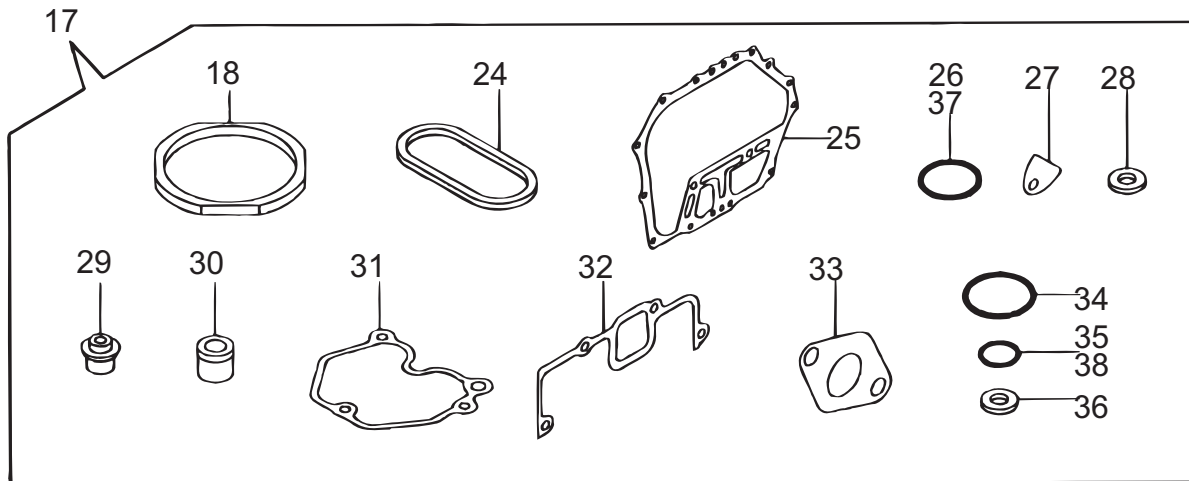
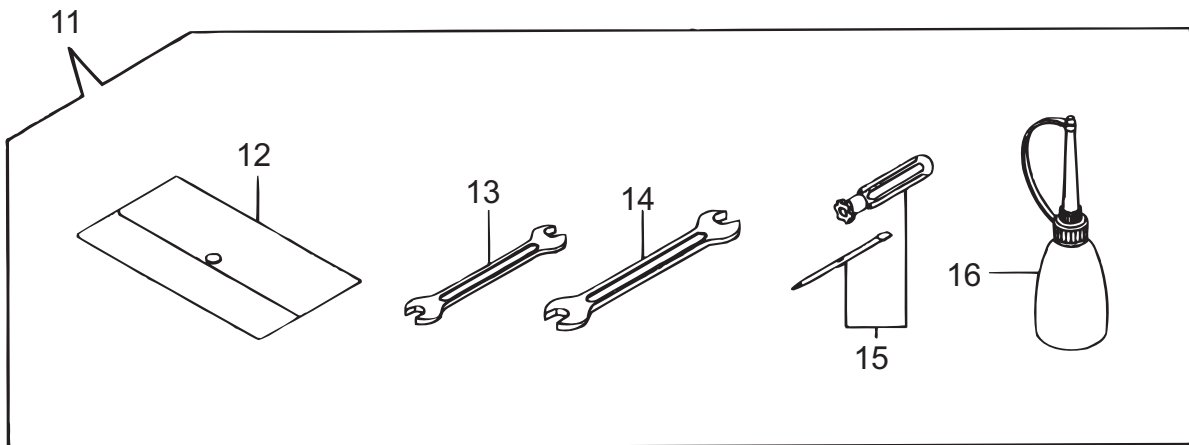
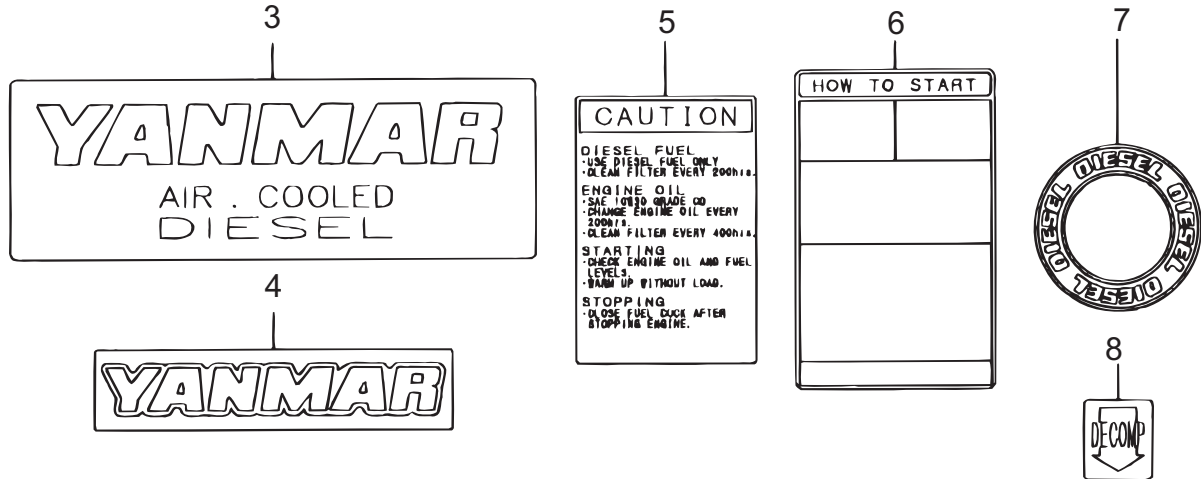

## YANMAR L100V1 — TOOL, LABEL AND GASKET SET

<u>NO.</u>	<u>PART NO.</u>	<u>PART NAME</u>	<u>QTY.</u>	<u>REMARKS</u>
3	11429907100	LABEL, AIR-COOLED	1	
4	11429907110	LABEL, YANMAR	1	
5	11421007120	LABEL, CAUTION	1	
6	11421007130	LABEL, HOW TO START-E	1	
7	11429907160	LABEL, DIESEL	1	
8	11421007200	LABEL, DECOMPRESSION	1	
11	11429992590	TOOL ASSY.....	1	INCLUDES ITEMS W/ #
12#	11429992600	TOOL BAG	1	
13#	11429992710	SPANNER	1	
14#	11429992720	SPANNER	1	
15#	11429992730	SCREWDRIVER	1	
16#	11429992740	FITTING, FUEL	1	
17	71465192620	GASKET SET .....	1	INCLUDES ITEMS W/ *
18*	11465101330	GASKET, CYLINDER HEAD CMP.	1	
24*	11469901380	O-RING	1	
25*	11469901410	GASKET, CRANKCASE	1	
26*	24311000180	O-RING P-18.0	2	
27*	11425001841	GASKET	1	
28*	22190160002	SEAL WASHER 16S	2	
29*	11465011340	SEAL, VALVE STEM	2	
30*	11477111461	GASKET, NOZZLE	1	
31*	11431011310	GASKET, BONNET	1	
32*	11431012210	GASKET, AIR INTAKE	1	
33*	11431013200	GASKET, MUFFLER	1	
34*	11429932570	O-RING, COVER	1	
35*	24341000100	O-RING 1A S-10.0	1	
36*	23414080000	GASKET 8, ROUND	1	
37*	24341000224	O-RING 1A S-22.4	1	
38*	24341000150	O-RING 1A S-15.0	1	

# TERMS AND CONDITIONS OF SALE — PARTS

## PAYMENT TERMS

Terms of payment for parts are net 30 days.

## FREIGHT POLICY

All parts orders will be shipped collect or prepaid with the charges added to the invoice. All shipments are F.O.B. point of origin. Multiquip's responsibility ceases when a signed manifest has been obtained from the carrier, and any claim for shortage or damage must be settled between the consignee and the carrier.

## MINIMUM ORDER

The minimum charge for orders from Multiquip is \$15.00 net. Customers will be asked for instructions regarding handling of orders not meeting this requirement.

## RETURNED GOODS POLICY

Return shipments will be accepted and credit will be allowed, subject to the following provisions:

1. A Returned Material Authorization must be approved by Multiquip prior to shipment.
2. To obtain a Return Material Authorization, a list must be provided to Multiquip Parts Sales that defines item numbers, quantities, and descriptions of the items to be returned.
  - a. The parts numbers and descriptions must match the current parts price list.
  - b. The list must be typed or computer generated.
  - c. The list must state the reason(s) for the return.
  - d. The list must reference the sales order(s) or invoice(s) under which the items were originally purchased.
  - e. The list must include the name and phone number of the person requesting the RMA.
3. A copy of the Return Material Authorization must accompany the return shipment.
4. Freight is at the sender's expense. All parts must be returned freight prepaid to Multiquip's designated receiving point.

5. Parts must be in new and resalable condition, in the original Multiquip package (if any), and with Multiquip part numbers clearly marked.
6. The following items are not returnable:
  - a. Obsolete parts. (If an item is in the price book and shows as being replaced by another item, it is obsolete.)
  - b. Any parts with a limited shelf life (such as gaskets, seals, "O" rings, and other rubber parts) that were purchased more than six months prior to the return date.
  - c. Any line item with an extended dealer net price of less than \$5.00.
  - d. Special order items.
  - e. Electrical components.
  - f. Paint, chemicals, and lubricants.
  - g. Decals and paper products.
  - h. Items purchased in kits.
7. The sender will be notified of any material received that is not acceptable.
8. Such material will be held for five working days from notification, pending instructions. If a reply is not received within five days, the material will be returned to the sender at his expense.
9. Credit on returned parts will be issued at dealer net price at time of the original purchase, less a 15% restocking charge.
10. In cases where an item is accepted, for which the original purchase document can not be determined, the price will be based on the list price that was effective twelve months prior to the RMA date.
11. Credit issued will be applied to future purchases only.

## PRICING AND REBATES

Prices are subject to change without prior notice. Price changes are effective on a specific date and all orders received on or after that date will be billed at the revised price. Rebates for price declines and added charges for price increases will not be made for stock on hand at the time of any price change.

Multiquip reserves the right to quote and sell direct to Government agencies, and to Original Equipment Manufacturer accounts who use our products as integral parts of their own products.

## SPECIAL EXPEDITING SERVICE

A \$35.00 surcharge will be added to the invoice for special handling including bus shipments, insured parcel post or in cases where Multiquip must personally deliver the parts to the carrier.

## LIMITATIONS OF SELLER'S LIABILITY

Multiquip shall not be liable hereunder for damages in excess of the purchase price of the item with respect to which damages are claimed, and in no event shall Multiquip be liable for loss of profit or good will or for any other special, consequential or incidental damages.

## LIMITATION OF WARRANTIES

No warranties, express or implied, are made in connection with the sale of parts or trade accessories nor as to any engine not manufactured by Multiquip. Such warranties made in connection with the sale of new, complete units are made exclusively by a statement of warranty packaged with such units, and Multiquip neither assumes nor authorizes any person to assume for it any other obligation or liability whatever in connection with the sale of its products. Apart from such written statement of warranty, there are no warranties, express, implied or statutory, which extend beyond the description of the products on the face hereof.

Effective: February 22, 2006



# OPERATION AND PARTS MANUAL

## HERE'S HOW TO GET HELP

PLEASE HAVE THE MODEL AND SERIAL  
NUMBER ON-HAND WHEN CALLING

### UNITED STATES

#### ***Multiquip Corporate Office***

18910 Wilmington Ave.  
Carson, CA 90746  
Contact: mq@multiquip.com

Tel. (800) 421-1244  
Fax (800) 537-3927

#### ***MQ Parts Department***

800-427-1244  
310-537-3700

Fax: 800-672-7877  
Fax: 310-637-3284

#### ***Service Department***

800-421-1244  
310-537-3700

Fax: 310-537-4259

#### ***Warranty Department***

800-421-1244  
310-537-3700

Fax: 310-943-2249

#### ***Technical Assistance***

800-478-1244

Fax: 310-943-2238

---

### MEXICO

#### ***MQ Cipsa***

Carr. Fed. Mexico-Puebla KM 126.5  
Momoxpan, Cholula, Puebla 72760 Mexico  
Contact: pmastretta@cipsa.com.mx

Tel: (52) 222-225-9900  
Fax: (52) 222-285-0420

### UNITED KINGDOM

#### ***Multiquip (UK) Limited Head Office***

Unit 2, Northpoint Industrial Estate,  
Globe Lane,  
Dukinfield, Cheshire SK16 4UJ  
Contact: sales@multiquip.co.uk

Tel: 0161 339 2223  
Fax: 0161 339 3226

### CANADA

#### ***Multiquip***

4110 Industriel Boul.  
Laval, Quebec, Canada H7L 6V3  
Contact: jmartin@multiquip.com

Tel: (450) 625-2244  
Tel: (877) 963-4411  
Fax: (450) 625-8664

© COPYRIGHT 2011, MULTIQUIP INC.

Multiquip Inc, the MQ logo and the Mikasa logo are registered trademarks of Multiquip Inc. and may not be used, reproduced, or altered without written permission. All other trademarks are the property of their respective owners and used with permission.

This manual MUST accompany the equipment at all times. This manual is considered a permanent part of the equipment and should remain with the unit if resold.

The information and specifications included in this publication were in effect at the time of approval for printing. Illustrations, descriptions, references and technical data contained in this manual are for guidance only and may not be considered as binding. Multiquip Inc. reserves the right to discontinue or change specifications, design or the information published in this publication at any time without notice and without incurring any obligations.

Your Local Dealer is:





## Free Manuals Download Website

<http://myh66.com>

<http://usermanuals.us>

<http://www.somanuals.com>

<http://www.4manuals.cc>

<http://www.manual-lib.com>

<http://www.404manual.com>

<http://www.luxmanual.com>

<http://aubethermostatmanual.com>

Golf course search by state

<http://golfingnear.com>

Email search by domain

<http://emailbydomain.com>

Auto manuals search

<http://auto.somanuals.com>

TV manuals search

<http://tv.somanuals.com>