

OPERATION AND PARTS MANUAL



***WHITEMAN* SERIES**

**WM120PH Series
POLYETHYLENE DRUM**

**WM120SH Series
STEEL DRUM**

**HYDRAULIC PLASTER/MORTAR MIXERS
(HONDA GASOLINE ENGINE/ELECTRIC MOTOR)**

Revision #7 (09/15/11)

To find the latest revision of this
publication, visit our website at:
www.multiquip.com



THIS MANUAL MUST ACCOMPANY THE EQUIPMENT AT ALL TIMES.



CALIFORNIA — Proposition 65 Warning

Engine exhaust and some of its constituents, and some dust created by power sanding, sawing, grinding, drilling and other construction activities contains chemicals known to the State of California to cause cancer, birth defects and other reproductive harm. Some examples of these chemicals are:

- Lead from lead-based paints.
- Crystalline silica from bricks.
- Cement and other masonry products.
- Arsenic and chromium from chemically treated lumber.

Your risk from these exposures varies, depending on how often you do this type of work. To reduce your exposure to these chemicals: **ALWAYS** work in a well ventilated area, and work with approved safety equipment, such as dust masks that are specially designed to filter out microscopic particles.

SILICOSIS/RESPIRATORY WARNINGS

WARNING



SILICOSIS WARNING

Grinding/cutting/drilling of masonry, concrete, metal and other materials with silica in their composition may give off dust or mists containing crystalline silica. Silica is a basic component of sand, quartz, brick clay, granite and numerous other minerals and rocks. Repeated and/or substantial inhalation of airborne crystalline silica can cause serious or fatal respiratory diseases, including silicosis. In addition, California and some other authorities have listed respirable crystalline silica as a substance known to cause cancer. When cutting such materials, always follow the respiratory precautions mentioned above.

WARNING



RESPIRATORY HAZARDS

Grinding/cutting/drilling of masonry, concrete, metal and other materials can generate dust, mists and fumes containing chemicals known to cause serious or fatal injury or illness, such as respiratory disease, cancer, birth defects or other reproductive harm. If you are unfamiliar with the risks associated with the particular process and/or material being cut or the composition of the tool being used, review the material safety data sheet and/or consult your employer, the material manufacturer/supplier, governmental agencies such as OSHA and NIOSH and other sources on hazardous materials. California and some other authorities, for instance, have published lists of substances known to cause cancer, reproductive toxicity, or other harmful effects.

Control dust, mist and fumes at the source where possible. In this regard use good work practices and follow the recommendations of the manufacturers or suppliers, OSHA/NIOSH, and occupational and trade associations. Water should be used for dust suppression when wet cutting is feasible. When the hazards from inhalation of dust, mists and fumes cannot be eliminated, the operator and any bystanders should always wear a respirator approved by NIOSH/MSHA for the materials being used.

TABLE OF CONTENTS

WM120PH/SH HYDRAULIC MIXER

Proposition 65 Warning	2
Silicosis/Respiratory Warnings	3
Table of Contents	4
Parts Ordering Procedures	5
Safety	6
Safety	7
Rules and Regulations	8-10
Towing Guidelines	11
Safety Chain Connection	12
Specifications	13
Dimensions	14
General Information	15
Mixer Components	16-17
Hydraulic Components	17
Engine Components	18
Electric Motor Components	19
Paddle Blade Adjustment (Steel Drum)	20
Paddle Blade Adjustment (Poly Drum)	21
Inspection	22-23
Initial Start-Up (Gasoline)	24
Initial start-up (Electric)	25
Operation	25-26
Shut-Down	27
Maintenance (Engine)	28-29
Maintenance (Mixer)	30-33
Storage	33
Troubleshooting (Engine)	34-35
Troubleshooting (Mixer/Electric motor)	36
Wiring Diagram (Electric Motor)	37
Hydraulic System Diagram	38
Explanation of Code in Remarks Column	40
Suggested Spare Parts	41

Component Drawings

Nameplate and Decals	42-43
Paddle Blades Assembly	44-45
Plastic Mixing Drum Assembly	46-47
Steel Drum Assembly (Manual)	48-49
Steel Drum Assembly (Hydraulic)	50-51
Paddle Shaft Assembly (Plastic/Steel)	52-53

Hydraulic Assembly	54-55
Frame 1 Assembly	56-57
Frame 2 Assembly	58-59
Frame 3 Assembly	60-61
Plastic Engine Cover Assembly	62-63
Steel Engine Cover Assembly	64-65
Single Phase, 5 HP Electric Motor Assembly ..	66-67
Three Phase, 5 HP Electric Motor Assembly ...	68-69

HONDA GX390K1QA2/ GX390U1QA2 Engine

Honda Engine Assembly	70-71
Air Cleaner Assembly	72-73
Camshaft Assembly	74-75
Piston Assembly	76-77
Crankcase Cover Assembly	78-79
Crankshaft Assembly	80-81
Cylinder Barrel Assembly	82-83
Cylinder Head Assembly	84-85
Fan Cover Assembly	86-87
Flywheel Assembly	88-89
Ignition Coil Assembly	90-91
Carburetor Assembly	92-93
Muffler Assembly	94-95
Recoil Starter Assembly	96-97
Control Assembly	98-99
Fuel Tank Assembly	100-101
Gasket Kit Assembly	102-103
Labels Assembly	104-105

Terms and Conditions of Sale — Parts	106
--	-----

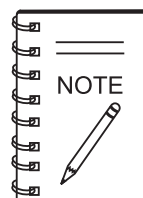

In accordance with our established policy of constant improvement, we reserve the right to amend these specifications at any time without notice.

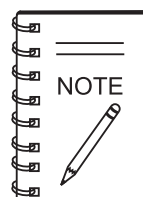

Specifications and part numbers are subject to change without notice.

PARTS ORDERING PROCEDURES

Ordering parts has never been easier! Choose from three easy options:

Effective:
January 1st, 2006

www.multiquip.com



Order via Internet (Dealers Only):

Order parts on-line using Multiquip's SmartEquip website!

- View Parts Diagrams
- Order Parts
- Print Specification Information



If you have an MQ Account, to obtain a Username and Password, E-mail us at: parts@multiquip.com.

To obtain an MQ Account, contact your District Sales Manager for more information.

Goto www.multiquip.com and click on

Order Parts to log in and save!

Use the **internet** and qualify for a **5% Discount** on *Standard orders* for all orders which include complete part numbers.*

Note: Discounts Are Subject To Change



Order via Fax (Dealers Only):

All customers are welcome to order parts via Fax.

Domestic (US) Customers dial:
1-800-6-PARTS-7 (800-672-7877)

Fax your order in and qualify for a **2% Discount** on *Standard orders* for all orders which include complete part numbers.*

Note: Discounts Are Subject To Change



Order via Phone: Domestic (US) Dealers Call:
1-800-427-1244

Non-Dealer Customers:

Contact your local Multiquip Dealer for parts or call 800-427-1244 for help in locating a dealer near you.



International Customers should contact their local Multiquip Representatives for Parts Ordering information.

When ordering parts, please supply:

- | | |
|---|--|
| <input type="checkbox"/> Dealer Account Number | <input type="checkbox"/> Specify Preferred Method of Shipment: |
| <input type="checkbox"/> Dealer Name and Address | <input checked="" type="checkbox"/> UPS/Fed Ex <input checked="" type="checkbox"/> DHL |
| <input type="checkbox"/> Shipping Address (if different than billing address) | <input type="checkbox"/> Priority One <input checked="" type="checkbox"/> Truck |
| <input type="checkbox"/> Return Fax Number | <input type="checkbox"/> Ground |
| <input type="checkbox"/> Applicable Model Number | <input type="checkbox"/> Next Day |
| <input type="checkbox"/> Quantity, Part Number and Description of Each Part | <input type="checkbox"/> Second/Third Day |

NOTICE

All orders are treated as *Standard Orders* and will ship the same day if received prior to 3PM PST.

WE ACCEPT ALL MAJOR CREDIT CARDS!



FOR YOUR SAFETY AND SAFETY OF OTHERS!

Safety precautions should be followed at all times when operating this equipment. Failure to read and understand the Safety Messages and Operating Instructions could result in injury to yourself and others.

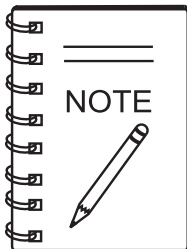

This manual has been developed to provide complete instructions for the safe and efficient operation of this equipment. Refer to the engine manufacturer's instructions for data relative to its safe operation.

Before using this equipment ensure that the operating individual has read and understood all instructions in this manual.

SAFETY MESSAGE ALERT SYMBOLS

The three Safety Messages shown below will inform you about potential hazards that could injure you or others. The Safety Messages specifically address the level of exposure to the operator, and are preceded by one of three words: **DANGER**, **WARNING**, or **CAUTION**.

DANGER

You **WILL** be **KILLED** or **SERIOUSLY INJURED** if you **DO NOT** follow these directions.

WARNING

You **CAN** be **KILLED** or **SERIOUSLY INJURED** if you **DO NOT** follow these directions.

CAUTION

You **CAN** be **INJURED** if you **DO NOT** follow these directions.

HAZARD SYMBOLS

Potential hazards associated with the operation of this equipment will be referenced with Hazard Symbols which appear throughout this manual, and will be referenced in conjunction with Safety Message Alert Symbols.

WARNING — Lethal Exhaust Gas Hazards



Engine fuel exhaust gases contain poisonous carbon monoxide. This gas is colorless and odorless, and can cause death if inhaled. **NEVER** operate this equipment in a confined area or enclosed structure that does not provide ample free flow air.

WARNING — Explosive Fuel Hazards



Fuel is extremely flammable and its vapors can cause an explosion if ignited. **DO NOT** start the engine near spilled fuel or combustible fluids.

DO NOT fill the fuel tank while the engine is running or hot. **DO NOT** overfill tank, since spilled fuel could ignite if it comes into contact with hot engine parts or sparks from the ignition system. Store fuel in approved containers, in well-ventilated areas and away from sparks and flames.

WARNING — Burn Hazards



Engine components can generate extreme heat. To prevent burns, **DO NOT** touch these areas while the engine is running or immediately after operation. Never operate the engine with heat shields or heat guards removed.

WARNING — Respiratory Hazards



ALWAYS wear approved respiratory protection when required.

CAUTION — Rotating Parts Hazards



NEVER operate equipment with covers or guards removed. Keep fingers, hands, hair and clothing away from all moving parts to prevent injury.

CAUTION — Overspeed Conditions



NEVER tamper with the factory setting of the engine governor. Personal injury and equipment damage can result if operating in speed ranges above the maximum allowable.

CAUTION — Accidental Starting Hazards



ALWAYS place the equipment ON/OFF switch in the OFF position when the equipment is not in use.

CAUTION — Equipment Damage Hazards

Other important messages are provided throughout this manual to help prevent damage to your equipment, other property, or the surrounding environment.

CAUTION — Eye and Hearing Hazards



ALWAYS wear approved eye and hearing protection.

CAUTION — Start/Stop Switch

ALWAYS test the start/stop switch for the gasoline engine or electric motor every time the engine or electric motor is started.

WARNING — Stand Clear of Mixer

Always stand clear of the dump handle when the mixer is in operation. Any binding of material between the mixer blades and the drum will cause the drum handle to quickly move and could cause bodily harm.

RULES AND REGULATIONS

WARNING — Read This Manual

Failure to follow instructions in this manual may lead to serious injury or even **DEATH!** This equipment is to be operated by trained and qualified personnel only! This equipment is for industrial use only.

GENERAL SAFETY

■ **DO NOT** operate or service this equipment before reading this entire manual.



■ This equipment should not be operated by persons under 18 years of age.

■ **NEVER** operate this equipment without proper protective clothing, shatterproof glasses, steel-toed boots and other protective devices required by the job.



■ **NEVER** operate this equipment when not feeling well due to fatigue, illness or when under medication.



■ **NEVER** operate this equipment under the influence of drugs or alcohol.



■ **NEVER** disconnect any "**emergency or safety devices**". These devices are intended for operator safety. Disconnection of these devices can cause severe injury, bodily harm or even death! Disconnection of any of these devices will void all warranties.

■ **NEVER** use accessories or attachments that are not recommended by Multiquip for this equipment. Damage to the equipment and/or injury to user may result.

■ Manufacturer does not assume responsibility for any accident due to equipment modifications. Unauthorized equipment modification will void all warranties.

■ Whenever necessary, replace nameplate, operation and safety decals when they become difficult read.

■ **ALWAYS** check the equipment for loosened threads or bolts before starting.

■ **NEVER** touch the hot exhaust manifold, muffler or cylinder. Allow these parts to cool before servicing engine or pump.



■ **ALWAYS** allow the engine to cool before adding fuel or performing service and maintenance functions. Contact with *hot* components can cause serious burns.

■ **NEVER** operate this equipment in any enclosed or narrow area where free flow of the air is restricted. The engine of this equipment requires an adequate free flow of cooling air. If the air flow is restricted it will cause serious damage to the equipment or engine and may cause injury to people and property. Remember the engine gives off **DEADLY** gases.



■ **ALWAYS** refuel in a well-ventilated area, away from sparks and open flames.

■ **ALWAYS** use extreme caution when working with **flammable** liquids. When refueling, **stop** the engine and allow it to cool.

■ **DO NOT** smoke around or near the equipment. Fire or explosion could result from fuel vapors, or if fuel is spilled on a hot engine.



■ **NEVER** operate the equipment in an explosive atmosphere or near combustible materials. An explosion or fire could result causing severe **bodily harm or even death**.



■ **DO NOT** top-off fuel tank. Topping-off is dangerous as it causes fuel to spill.

■ **ALWAYS** store the equipment in a clean, dry location out of the reach of children.

■ **NEVER** run engine without air cleaner or air filter. Severe engine damage may occur.

■ **NEVER** leave the equipment unattended with the engine running. Turn off engine when unattended.

■ **CAUTION** must always be observed while servicing this equipment. Rotating parts can cause injury if contacted.

RULES AND REGULATIONS

- When towing, an adequate safety chain must be fastened to the frame. See Towing Guidelines section in this manual.
- Keep all ***inexperienced*** and ***unauthorized*** people away from the equipment at all times.
- Unauthorized equipment modifications will void all warranties.
- Check all fasteners periodically for tightness. Also check towing tongue bolt, lock nut and wheel lug nuts for wear.
- Stop the engine and disconnect the spark plug before allowing anybody's hands in the mixing drum.
- **NEVER** pour or spray water over the engine or electric motor.
- When towing, an adequate safety chain must be fastened to the frame. See Towing Guidelines section in this manual.
- Keep all ***inexperienced*** and ***unauthorized*** people away from the equipment at all times.
- Unauthorized equipment modifications will void all warranties.
- Check all fasteners periodically for tightness. Also check towing tongue bolt, lock nut and wheel lug nuts for wear.
- Stop the engine and disconnect the spark plug before allowing anybody's hands in the mixing drum.
- **NEVER** pour or spray water over the engine or electric motor.
- Depending on type of mixer, test the ***ON/OFF*** switch for either the gasoline engine or electric motor before operating. The purpose of these switches is to shut down the engine or motor of the mixer
- **ALWAYS** stand clear of the release drum lock. Move handle downward to empty the drum. Move handle upward to return to vertical position. Inspect for proper functionality before starting engine or engaging blades. Any binding of material between the mixing blades & drum will cause the handle to quickly rotate if not in the "up & locked" position.
- **DO NOT** operate this equipment unless all guards and safety devices are attached and in place.
- Refer to the ***HONDA Engine Owner's Manual*** for engine

WARNING — Manual Dump Drum Handle

Always stand clear of dump handle when equipment is in operation.

technical questions or information recommended by Multiquip for this equipment. Damage to the equipment and/or injury to user may result.

TRANSPORTING

- **ALWAYS** shutdown engine before transporting.
- Tighten fuel tank cap securely and close fuel cock to prevent fuel from spilling.
- Drain fuel when transporting equipment over long distances or bad roads.

MAINTENANCE SAFETY

- **NEVER** lubricate components or attempt service on a running machine.
- **ALWAYS** allow the machine a proper amount of time to cool before servicing.
- Keep the equipment in proper running condition.
- Fix damage to the equipment immediately and always replace broken parts.
- Dispose of hazardous waste properly. Examples of potentially hazardous waste are used motor oil, fuel and fuel filters.
- **DO NOT** use food or plastic containers to dispose of hazardous waste.
- **DO NOT** pour waste, oil or fuel directly onto the ground, down a drain or into any water source.

RULES AND REGULATIONS

EMERGENCIES

- **ALWAYS** know the location of the nearest **fire extinguisher**.



- **ALWAYS** know the location of the nearest **first aid kit**.



- In emergencies, **always** know the location of the nearest phone or **keep a phone on the job site**. Also know the phone numbers of the nearest **ambulance, doctor** and **fire department**. This information will be invaluable in case of emergency.



TOWING SAFETY PRECAUTIONS

CAUTION — Inspect Towing Components

To reduce the possibility of an accident while transporting the machine on public roads, always make sure that the equipment's towing components and the towing vehicle are in good operating condition and both units are mechanically sound. Remember before towing, **check with local and state laws for proper compliance.**

The following list of suggestions should be used when towing the mixer:

- Check with your county or state safety towing regulations department before towing your **mixer**.
- Make sure that the hitch and coupling of the towing vehicle are rated equal to, or greater than the trailer "gross vehicle weight rating" (GVWR).
- **ALWAYS** inspect the hitch and coupling for wear. **NEVER** tow the mixer with defective hitches, couplings, chains etc.
- **CHECK** the tire air pressure on both the towing vehicle and the trailer. Also check the tire tread wear on both vehicles.
- **ALWAYS** make sure the mixer is equipped with a "Safety Chain."
- **ALWAYS** attach trailer's safety chain to the frame of towing vehicle.
- **ALWAYS** make sure that the towing vehicle's directional, backup, and brake lights are working properly.
- Remember in most cases the maximum speed unless otherwise posted for highway towing is **55 MPH**, however before towing your mixer, check your local state, and county vehicle towing requirements. Recommended off-road towing is not to exceed **10 or 15 MPH** or less depending on type of terrain.
- Place **chocked blocks** underneath wheels to prevent **rolling**, while parked, if disconnected from towing vehicle.
- Inflate tires to correct pressure, inspect tires for cuts, and excessive wear. See Table 9 (Tire Wear Troubleshooting).
- When towing of the mixer is required, place the drum in the up position (mouth facing upwards) and lock the drum latch.

- **ALWAYS** make sure that the fuel valve lever is in the **OFF** position (gasoline models only).
- Check wheel mounting lug nuts with a **torque wrench**. Torque wheel lug nuts as described in the maintenance section of this manual.
- Check tightness of U-clamp nuts, torque suspension hardware as referenced in the maintenance section of this manual.
- Avoid sudden stops and starts. This can cause skidding, or jackknifing. Smooth, gradual starts and stops will improve gas mileage.
- Avoid sharp turns to prevent rolling.

Tow bar to vehicle connection (Coupler only)

1. Check the vehicle hitch ball, and mixer's coupler for signs of wear or damage. Replace any parts that are worn or damaged before towing.
2. Use only a 2-inch ball diameter (towing vehicle), this will

CAUTION — Replacing Towing Components

If the mixer tow bar is deformed or damaged, replace the **entire** tow bar. **NEVER** tow the mixer with a defective tow bar. There exists the possibility of the mixer separating from the towing vehicle.

match the mixer's 2-inch coupler. Use of any other ball diameter will create an extremely dangerous condition which can result in separation of the coupler and ball or ball failure.

3. After tow bar has been connected to mixer (see next page), attach mixer's coupler to the hitch ball on the towing vehicle securely and make sure the lock lever is in the down position (locked).

Mixer Tow Bar Vehicle Connection (Pentle and Loop)

1. Make sure the bumper on the towing vehicle is equipped to handle either a pintle or loop type tow bar configuration.
2. After tow bar has been connected to mixer (see next page), secure either type of tow bar to the towing vehicle, following state and county towing regulations.
3. As a minimum, use a 1/2-inch bolt and nylock nut grade 5 when securing the tow bar to the towing vehicle and to the unit being towed.

SAFETY CHAIN CONNECTION

CAUTION — Tow With Safety Chain

NEVER! tow the mixer with the safety chain removed. The safety chain is intended to prevent complete separation of the mixer from the towing vehicle in the event of a tow bar failure.

Reference Figure 1 for the installation of the **safety chain**.

TOW BAR TO MIXER CONNECTION

1. Insert the tow bar through the round opening at the bottom of the mixer stand.

Align the hole on the tow bar with the hole on the mixer frame, and insert 1/2-inch bolt through tow bar and frame. Secure tow bar to frame with 1/2-inch nylock nut. Tighten to 40 ft.-lbs.

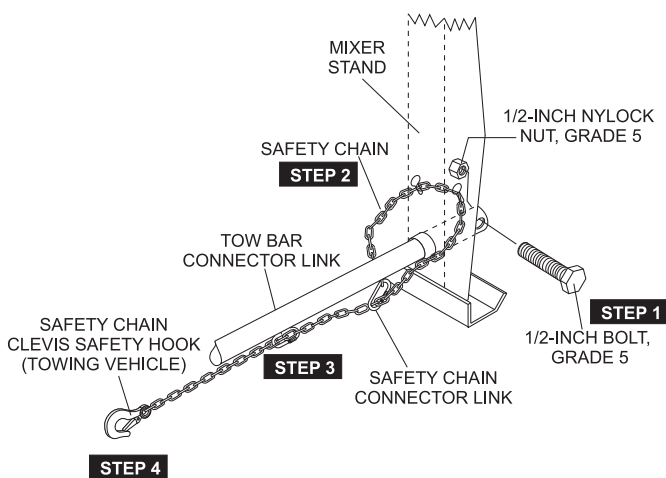

Figure 1. Tow Bar and Safety Chain Installation

2. Route the safety chain through the holes just above the tow bar, located on each side of the mixer stand. Loop the chain together and place under the tow bar. Secure the loop with the connector link.
3. Extend the safety chain along the length of the tow bar, looping it through the tow bar's connector link. Remove any excess chain slack.
4. Connect the free end of (clevis safety hook) the safety chain to the towing vehicle. Remember it is critical that the length of the chain be properly adjusted, to prevent the draw bar and the front of the mixer stand from dropping to the the ground (contact) in the event the draw bar becomes disconnected from the towing vehicle.



If a new safety chain is required use P/N 13363. For a new connector link use P/N 01004.

CAUTION — Drum Safety When Towing

DO NOT tow the mixer unless the mixing drum is **completely empty**. **ALWAYS** make sure the drum lock lever (Figure 24) is in the verticle position (manual dump mixers only).

SPECIFICATIONS

Table 1 Specifications Mixer

Mixer Model		Drum Capacity cu. ft (liters)	Drum Capacity 94 lbs. (42 kg.) Bag Portland Cement	Weight lbs. (kg.)	L x W x H in. (cm.)	Discharge Height in. (cm.) From Stop	Drive	Dump Action
STEEL	WM120SE1	12 (340)	3.5 to 4	1,040 (472)	84 x 56 x 62 (213 x 142 x 157)	18 (46)	Hydraulic	Manual
	WM120SE1D			1,065 (484)				Hydraulic
	WM120SE3			1,050 (476)				Manual
	WM120SE3D			1,075 (488)				Hydraulic
	WM120PHH			1,085 (492)				Manual
	WM120SHHD			1,110 (505)				Hydraulic
	WM120PHHDS*			1,400 (435)	84 x 56 x 62 (213 x 142 x 157)	Hydraulic		
PLASTIC	WM120PE1	12 (340)	3.5 to 4	1,035 (469)	87 x 59 (221 x 142)*	18 (46)	Hydraulic	Manual
	WM120PE1D			1,060 (481)				Hydraulic
	WM120PE3			1,045 (475)				Manual
	WM120PE3D			1,070 (486)				Hydraulic
	WM120PH			1,060 (481)				Manual
	WM120PHD			1,085 (493)				Hydraulic

Stationary mixer no wheels. Height is adjustable from 54-67 in. (1.4-1.7 m)

TABLE 2. SPECIFICATIONS (ENGINE/ELECTRIC MOTOR)

Engine/Electric Motor	Model	HONDA GX390K1QA2/ GX390U1QA2	BALDOR 3646LC	BALDOR 3634M
	Type	Air-cooled 4 stroke, Horizontal Shaft Gasoline Engine	5 HP, 230 VAC, Single Phase Electric Motor	5 HP, 230/460 VAC, Three Phase Electric Motor
	Bore X Stroke	3.46 in. X 2.51 in. (88 mm x 64 mm)	N/A	N/A
	Displacement	389 cc. (23.7 cu-in)	N/A	N/A
	Max Output	11.0 HP/3600 R.P.M	5.0 H.P./1725 RPM	5.0 H.P./1750 RPM
	Continuous Output	9.0 HP/3600 R.P.M	N/A	N/A
	Full Load Amps	N/A	23	13.4/6.7
	Fuel Tank Capacity	1.7 US gals. (6.5 liters)	N/A	N/A
	Fuel	Unleaded Gasoline	N/A	N/A
	Lube Oil Capacity	1.16 qts (1.1 liters)	N/A	N/A
	Speed Control Method	Centrifugal Fly-weight Type	N/A	N/A
	Starting Method	Recoil Start	N/A	N/A

DIMENSIONS

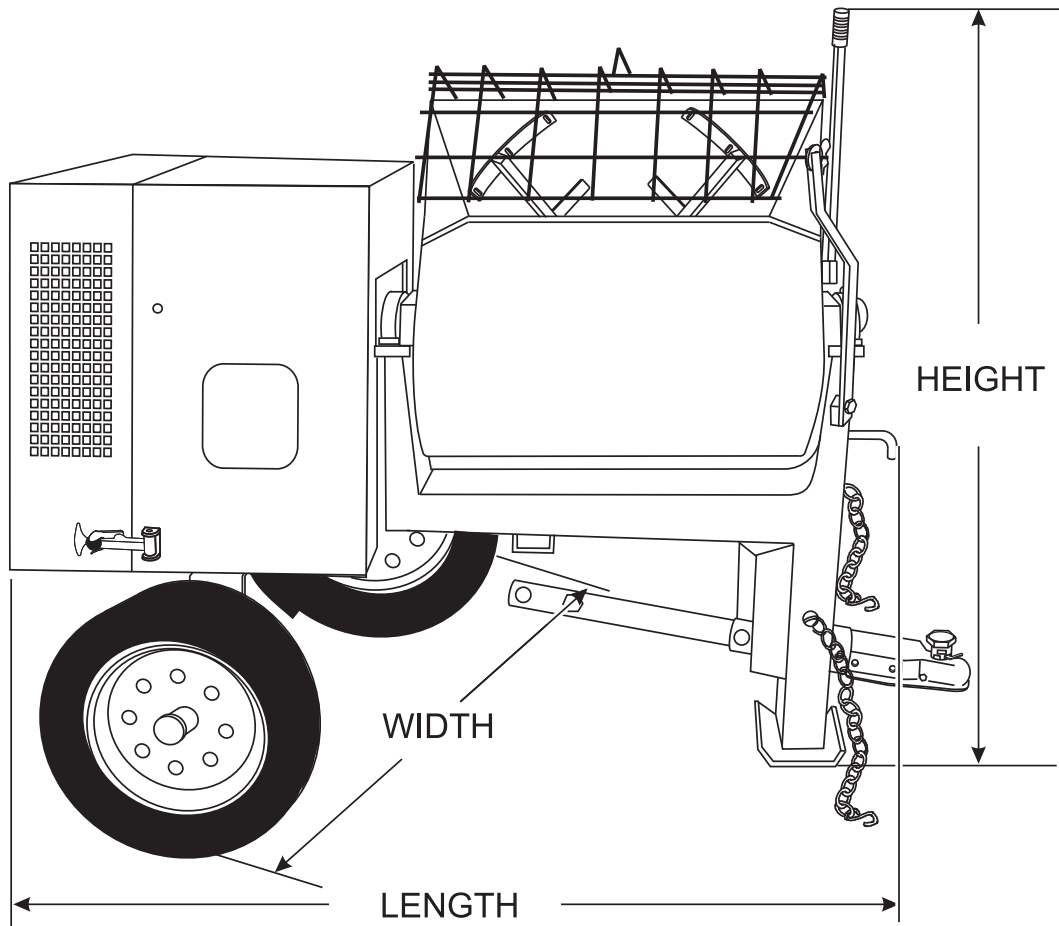

OPTIONAL TOW BARS
APPROXIMATE LENGTH
36 IN. (91.44 CM.)

HPC-1
1-INCH
PIN COUPLER

HBC-1
2-INCH
BALL COUPLER

HLC-1
LOOP COUPLER

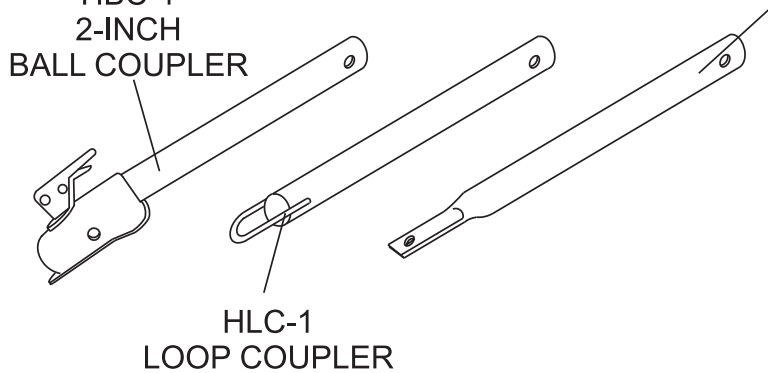

Table 3. Dimensions	
Description	Dimensions in. (cm.)
Length	84 in. (213 cm.)
Width	56 in. (142 cm.)
Height	62 in. (157 cm.)

Figure 2. Dimensions

Application

The MQ WM120 series hydraulic mixers (drum capacity 12.0 cu. ft./340 liters) are shipped completely assembled and have been factory tested and are ready for use.

This mixer is only intended for the mixing of plaster and mortar. The mixer must be used for its intended purpose and is not suitable for the mixing of flammable or explosive substances. The mixer must not be used in an explosive atmosphere. This mixer has a batch capacity between 3-1/2 and 4-1/2 bags.

Power Plants

These hydraulic mixers can be powered by either a 11 HP Honda GX390 air-cooled, 4-stroke gasoline engine or a 5.0 HP electric motor. Refer to Table 2 for specific engine or electric motor data information.

Electrical

If mixer is equipped with an **electric motor**, make sure that the power being supplied to the motor corresponds to the voltage rating label on the motor. Supplying the wrong voltage to the electric motor will cause severe electrical damage to the motor.

Always make sure the **OFF/ON** switch on the electric motor is in the **OFF** position before applying power.

Extension Cables

The extension cable should be a 3-wire configuration that includes a ground wire that conforms to UL code. The wire cross section must be a minimum of 2.5 mm². Choose an extension cord of adequate current carrying capacity as referenced in Table 5. Remember **cable distance** affects the current-voltage capacity of the extension cable.

Ensure that the extension cable is carefully laid out avoiding **wet areas, sharp edges** and locations where vehicles might run over it. Avoid allowing the extension cable to be trapped underneath the mixer.

Unroll the extension cable fully or it will overheat and could catch fire. Make sure that all extension cable connections are dry and safe. Replace any defective or badly worn extension cable immediately.

Hardware

Check all hardware on the mixer before starting. Periodically inspect all hardware. Loose hardware can contribute to early component failure and poor performance. Use Table 4 as general guideline when torquing of mixer hardware is required. Remember to keep all mixer hardware components tight.

Engine Maintenance

For basic engine maintenance, refer to the engine maintenance section in this manual. For a more detailed engine maintenance, refer to the **Honda** Engine Owner's manual furnished with the engine.

Table 4. Hardware Torque Recommendations

Hardware Diameter	Torque (ft-lbs)
5/16-inch x 18	14
3/8-inch x 16	24
3/8-inch x 24	37
1/2-inch x 13	39
1/2-inch x 13 (Grade 8)	90

MIXER COMPONENTS

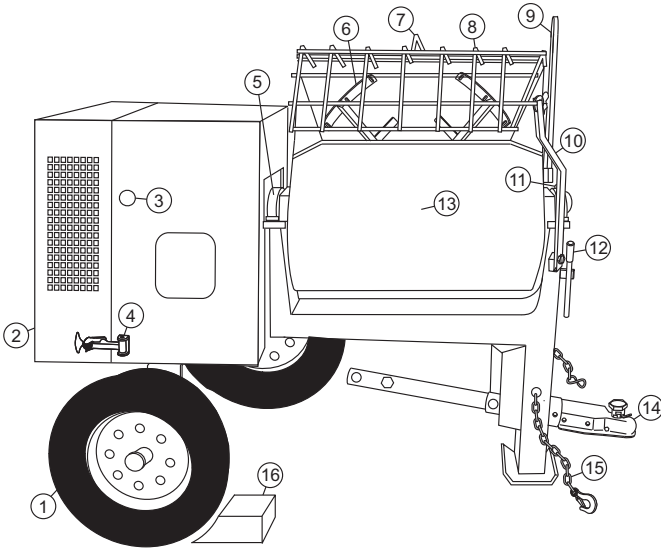

Figure 3. Mixer Components (Wheels)

Figures 3 and 4 illustrate the basic components and controls of the WM120 series hydraulic mixer

1. **Tires** — Replace with manufacturer recommended tires only. This mixer requires 13-inch 4-ply tires.
2. **Engine Cover** — Lift this cover to gain access to the engine or electric motor.
3. **ON/OFF Switch (gasoline)** — This switch is provided on *mixers with gasoline* engines only and is located on the side of the engine cover. When activated it will shut down the engine.
4. **Latch** — Use this latch to secure the engine/electric motor compartment enclosure.
5. **Drum Bearing** — There is a sealed bearing on each end of the mixing drum. Bearings are packed and sealed at the factory and require no further maintenance.
6. **Mixing Paddles** — This mixer uses plastic and rubber mixing paddles for the mixing of plaster and mortar. Always clean paddles after each use.
7. **Bag Cutter** — This feature allows mixing bags to be opened easily, therefore allowing the contents of the bag to fall directly into the mixing drum.
8. **Safety Grill** — Provided for operator safety. This safety grill is designed to keep hands and solid objects out of the mixing drum when in use. This grill should be closed at all times when mixer is in use. **DO NOT** remove the grill or grill opening bar. Keep the grill clean by washing it down daily.
9. **Manual Dump Handle** — Pull this handle downward to dump the contents of the drum. Push the handle upward to return the drum to its vertical position. This feature is not available on hydraulic dump models.
10. **Safety Grill Lock Handle** — To prevent injury to hands and arms, the safety grill should **ALWAYS** be locked when the mixing of plaster or mortar is required. Also when transporting the mixer the safety grill should be locked. The safety grill should only be un-locked when cleaning of the blades and drum is required.
11. **Pivot Point/Zerk Fitting** — There is a zerk grease fitting on each end of the mixing drum. These fittings lubricate the dumping mechanism. Lubricate both fittings at least twice a week.
12. **Drum Lock Lever** — Rotate this lever horizontally to lock the drum for mixing. Rotate vertically to release the drum for dumping. This feature is not available on hydraulic dump models.
13. **Mixing Drum** — Mixing drums are available in two types of materials plastic and steel. Drum capacity is 12 cu. ft (340 liters). Mixing materials such as mortar, plaster are to be placed into this drum for mixing. Always clean drum after each use.
14. **Tow Bar/Coupler** — This mixer uses a 2-inch coupler or pintle towbar.
15. **Safety Chain** — This mixer uses a 3/16-inch thick, 72-inches long zinc-plated safety chain. **ALWAYS** connect the safety chain when towing.
16. **Chock Blocks** — Place these blocks (not included as part of the mixer package) under each mixer wheel to prevent rolling.

MIXER COMPONENTS/HYDRAULIC COMPONENTS

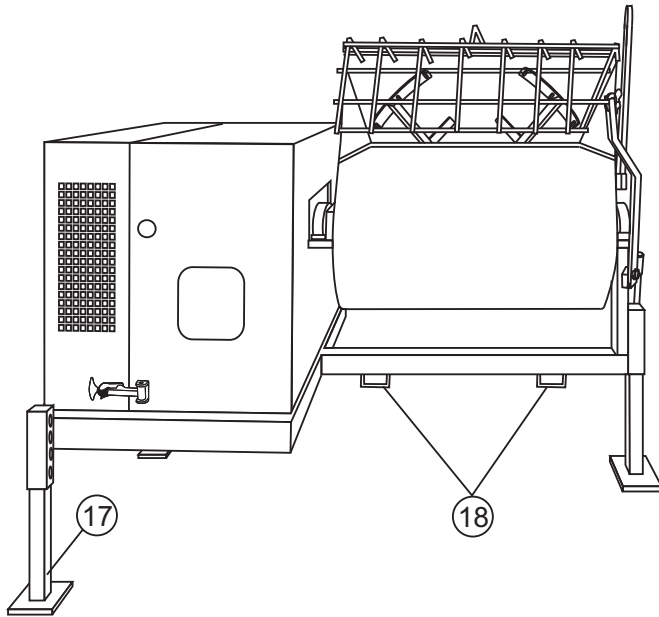

Figure 4. Mixer Components (Stationary)

17. **Adjustable Stabilizer Jack Stands** — Use these jack stands (3) to adjust the mixer to the desired height.
18. **Forklift Pockets** — When lifting of the mixer is required, use these fork lift pockets to lift the mixer. Remember to insert the forks of the forklift a minimum of 24 inches into the lift pockets. This feature is only available on the stationary mixer model.

HYDRAULIC COMPONENTS

Figure 5 illustrates the hydraulic components used on the mixer.

1. **Hydraulic Motor** — Bi-directional hydraulic motor that is used in conjunction with the directional control valve to operate the hydraulic dump cylinder and paddle shaft.
2. **Hydraulic Dump Cylinder** — When activated, this cylinder will cause the mixing drum to rotate to the dump position. This cylinder is provided only on mixers with *hydraulic dump* capability only.
3. **Hydraulic Oil Sight Gauge** — This gauge indicates the level and temperature of the hydraulic oil. For normal operation oil level should be visible at the midpoint on the sightglass.
4. **Hydraulic Valve** — Directional hydraulic control valve. Controls the direction of hydraulic fluid supplied to the dump cylinder and paddle shaft.

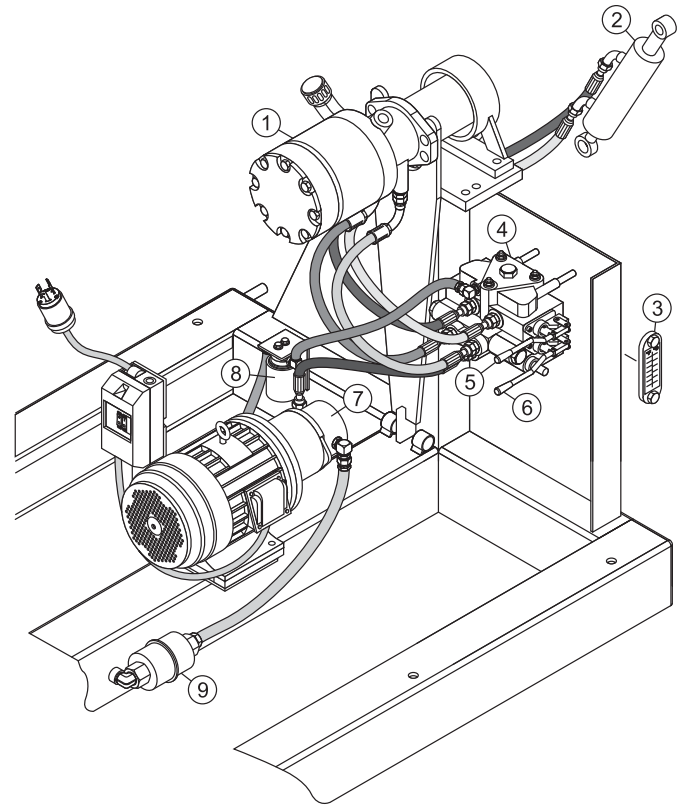

Figure 5. Hydraulic Components

5. **Hydraulic Dump Lever** — This lever is provided on mixers with *hydraulic dump* capability only. Pull lever outward to activate dump cylinder.
6. **Hydraulic Paddle Blade Lever** — 3-position lever. Push inward for clockwise mixing rotation of blades. Place in center position for no rotation (neutral/off).
7. **Pump** — Supplies hydraulic fluid to the hydraulic control valve.
8. **Hydraulic Oil Filter** — 10 micron hydraulic filter. Filters out small particles that are harmful to the hydraulic system.
9. **Strainer** — Filters out large particles and debris that are harmful to the hydraulic system.

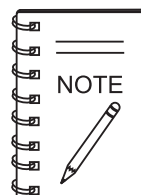

Figure 5 shows configuration for electric motor. Gasoline engine is configured in the same manner.

ENGINE COMPONENTS

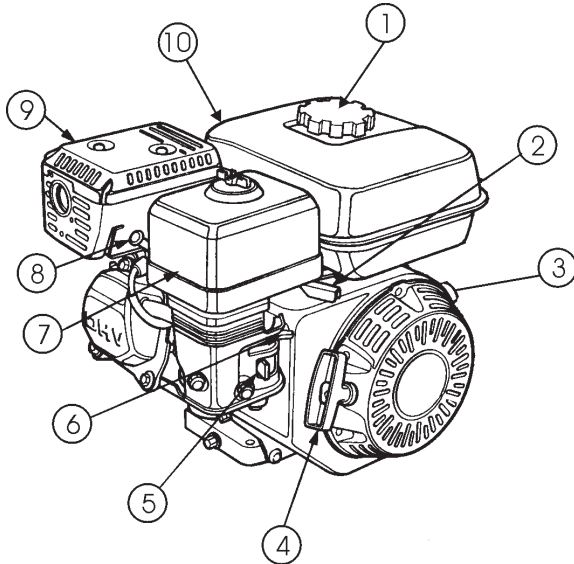

Figure 6. Engine Controls and Components

INITIAL SERVICING

The engine (Figure 6) must be checked for proper lubrication and filled with fuel prior to operation. Refer to the manufacturer's engine manual for instructions & details of operation and servicing.

1. **Fuel Filler Cap** – Remove this cap to add unleaded gasoline to the fuel tank. Make sure cap is tightened securely. **DO NOT** over fill.

DANGER — Explosive Fuel Hazards



Fuel is extremely flammable and its vapors can cause an explosion if ignited. **DO NOT** start the engine near spilled fuel or combustible fluids. In the event of a fuel spill, wait until the fuel residue has been completely wiped up and the area surrounding the engine is dry before starting the engine.

DO NOT fill the fuel tank while the engine is running or hot. **DO NOT** overfill tank, since spilled fuel could ignite if it comes into contact with hot engine parts or sparks from the ignition system. Store fuel in approved containers, in well-ventilated areas and away from sparks and flames.

2. **Throttle Lever** – Used to adjust engine RPM speed (lever advanced forward **SLOW**, lever back toward operator **FAST**).
3. **Engine ON/OFF Switch** – **ON** position permits engine starting, **OFF** position stops engine operations.

4. **Recoil Starter (pull rope)** – Manual-starting method. Pull the starter grip until resistance is felt, then pull briskly and smoothly.
5. **Fuel Valve Lever** – **OPEN** to let fuel flow, **CLOSE** to stop the flow of fuel.
6. **Choke Lever** – Used in the starting of a cold engine, or in cold weather conditions. The choke enriches the fuel mixture.
7. **Air Cleaner** – Prevents dirt and other debris from entering the fuel system. Remove wing-nut on top of air filter cannister to gain access to filter element.



Operating the engine without an air filter, with a damaged air filter, or a filter in need of replacement will allow dirt to enter the engine, causing rapid engine wear.

WARNING — Burn Hazards



Engine components can generate extreme heat. To prevent burns, **DO NOT** touch these areas while the engine is running or immediately after operation. Never operate the engine with the muffler removed.

8. **Spark Plug** – Provides spark to the ignition system. Set spark plug gap to 0.6 - 0.7 mm (0.028 - 0.031 inch) Clean spark plug once a week.
9. **Muffler** – Used to reduce noise and emissions.
10. **Fuel Tank** – Holds unleaded gasoline. Fuel tank capacity is 1.7 gallons (6.5 liters) For additional information refer to engine owner's manual.

ELECTRIC MOTOR COMPONENTS

ELECTRIC MOTOR

For lubrication care and operation of the electric motor, refer to your electric motor instruction booklet furnished with the motor.

Protect the electric motor from dust as much as possible and keep ventilating openings clean.

⚠ CAUTION

DO NOT spray water at any time on the **electric motor**.

DO NOT operate electric motor in an explosive environment.

The electric motors (Figure 7) used on these mixers is available in two types of configurations, 5 HP 1Ø @230 VAC or 5 HP 3Ø @230/460 VAC. Pay special attention to the nameplate on the electric motor when supplying power to the electric motor. Applying incorrect power to the motor can severely damage the motor and may cause serious bodily injury!

Always make certain that the correct voltage is being supplied to the motor. The input voltage requirements can be found on the electric motor's nameplate.

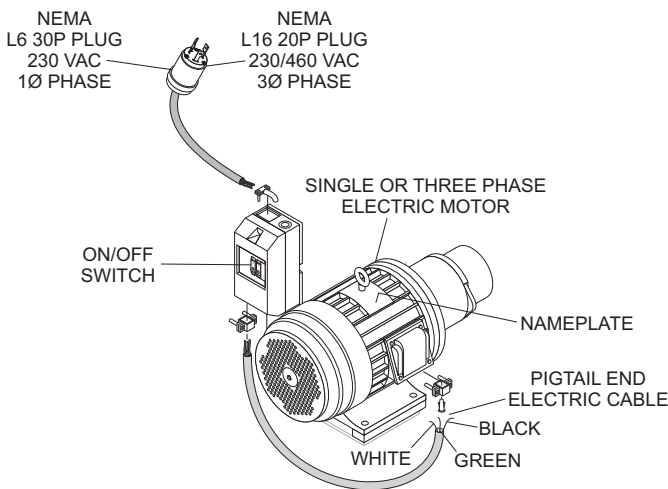
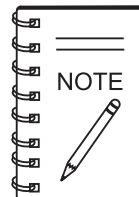

Figure 7. Electric Motor

Electric Motor Connection

The electrical motors used on these mixers are equipped with either a 3-prong (1Ø) or a 4-prong (3Ø) plug (Figure 7) for connection to a power source. Reference Table 5. to determine the required NEMA mating receptacle.



It is strongly recommended that all electrical wiring be done by a **licensed electrician**. Pay special attention to the nameplate on the electric motor. Make certain that the voltage supplied to the electric motor matches the required operating voltage printed on the nameplate.

Table 5. Electric Motor Wiring Information		
Electric Motor Horsepower Rating	230 VAC - 1Ø Phase	230/460 VAC - 3Ø Phase
5 HP	NEMA Plug Connector 3-Prong L6-30P P/N 201794	NEMA Plug Connector 4-Prong L16-20P P/N 111012320
	NEMA Receptacle Connector 3-Prong L6-30R P/N TBD	NEMA Receptacle Connector 4-Prong L16-20R P/N 110012340

PADDLE BLADE ADJUSTMENT (STEEL DRUM)

Adjust paddles as shown in Figure 8.

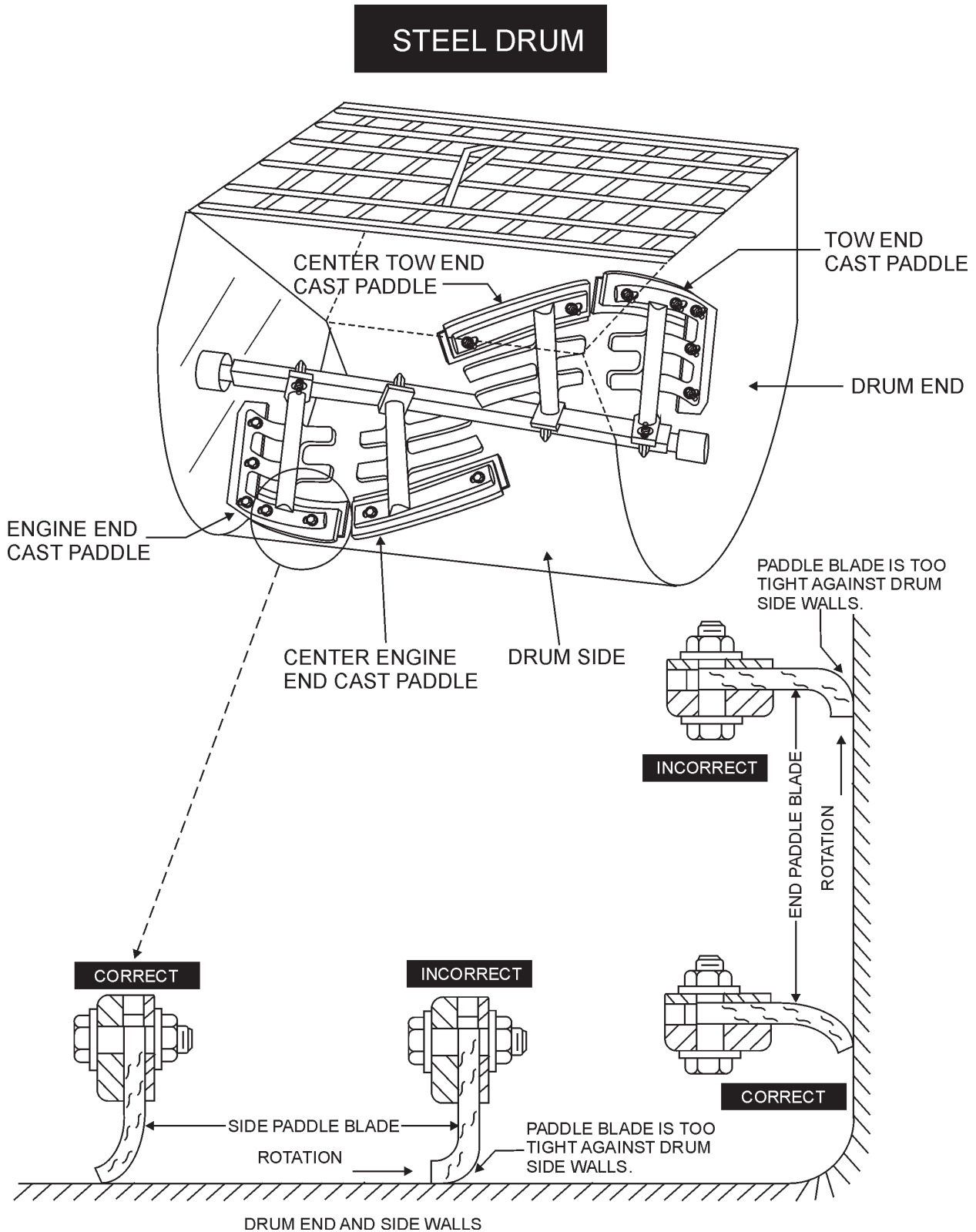

Figure 8. Paddle Blade Adjustment (Steel Drum)

PADDLE BLADE ADJUSTMENT (POLY DRUM)

Adjust paddles as shown in Figure 9.

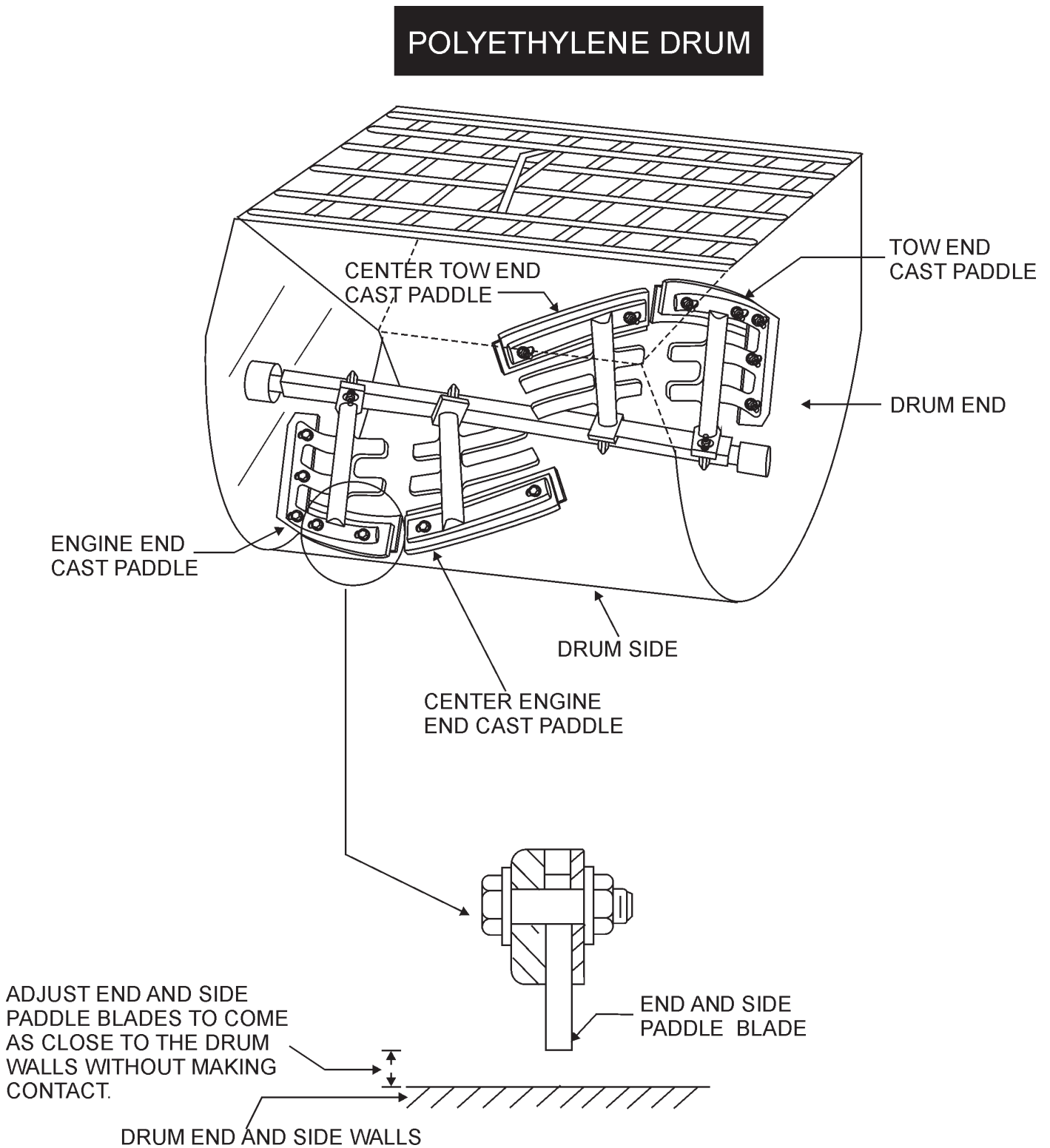

Figure 9. Paddle Blade Adjustment (Poly Drum)

This section is intended to assist the operator with the inspection of the hydraulic mixer. It is extremely important that this section be read carefully before attempting to use the mixer in the field.

DO NOT use your mixer until this section is thoroughly understood.

BEFORE STARTING

1. Read *all safety instructions at the beginning of manual.*
2. Clean the **mixer**, removing dirt and dust, particularly the engine cooling air inlet, carburetor and air cleaner.
3. Check the air filter for dirt and dust. If air filter is dirty, replace air filter with a new one as required.
4. Check carburetor for external dirt and dust. Clean with dry compressed air.
5. Check fastening nuts and bolts for tightness.

ENGINE OIL CHECK

1. To check the engine oil level, place the mixer on secure level ground with the engine stopped.
2. Remove the filler dipstick from the engine oil filler hole (Figure 10) and wipe it clean.

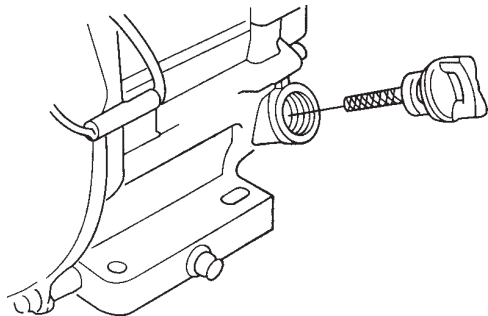
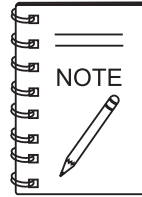

Figure 10. Engine Oil Dipstick (Removal)

3. Insert and remove the dipstick without screwing it into the filler neck. Check the oil level shown on the dipstick.
4. If the oil level is low (Figure 11), fill to the edge of the oil filler hole with the recommended oil type (Table 6). Maximum oil capacity is 1.16 quarts (1.1 liters).



Reference manufacturer engine manual for specific servicing instructions.

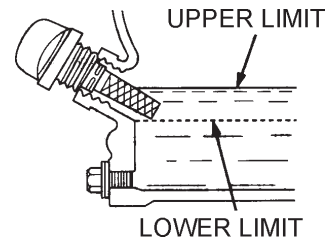

Figure 11. Engine Oil Dipstick (Removal)

TABLE 6. OIL TYPE

Season	Temperature	Oil Type
Summer	25°C or Higher	SAE 10W-30
Spring/Fall	25°C~10°C	SAE 10W-30/20
Winter	0°C or Lower	SAE 10W-10

FUEL CHECK

! DANGER — Explosive Fuel Hazards



If your mixer has a gasoline engine, determine if the engine fuel is low. If fuel is low, remove the fuel filler cap and fill it with **unleaded** gasoline. Motor fuels are highly flammable and can be dangerous if mishandled. **DO NOT** smoke while refueling. **DO NOT** attempt to refuel the mixer if the engine is **hot!** or **running.**

! CAUTION — Start/Stop Switch

NEVER! disable or disconnect the **start/stop switch.** It is provided for operator safety. Injury may result if it is disabled, disconnected or improperly maintained.

1. Remove the gasoline cap located on top of fuel tank.
2. Visually inspect to see if fuel level is low. If fuel is low, replenish with **unleaded** fuel.
3. When refueling, be sure to use a strainer for filtration. **DO NOT** top-off fuel. Wipe up any spilled fuel.

HYDRAULIC OIL

Check hydraulic oil sight gauge (Figure 12) to ensure that hydraulic oil is at the midway level.



Figure 12. Hydraulic Oil Sight Gauge

HYDRAULIC HOSES

Check hydraulic hoses to make sure they are not worn, frayed or defective.

GREASE FITTINGS (BEARINGS)

Check the zerk grease fittings (Figure 13) on the bearing housings and dump support brackets at each end of the mixing drum. These grease fittings lubricate the dumping mechanism. If the dumping handle is stiff or hard to move lubricate these fittings.

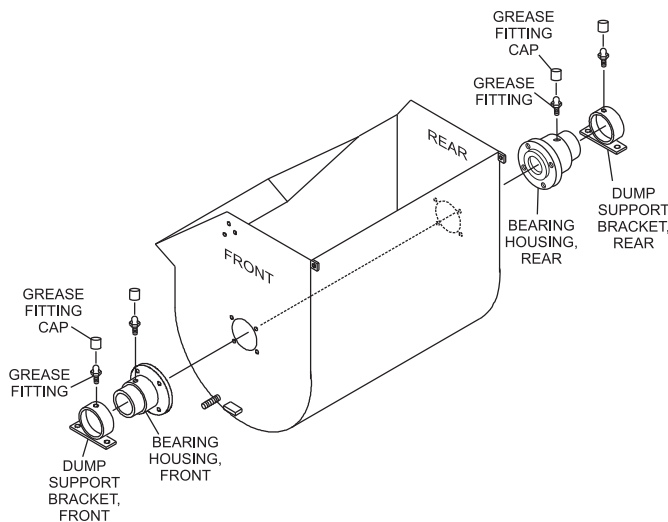

Figure 13. Grease Fittings (Bearings)

GREASE FITTING (DUMP CYLINDER)

1. If your unit has hydraulic dump capability, check the zerk grease fitting at the top of the dump cylinder (Figure 14). This grease fitting lubricates the hydraulic dumping mechanism.

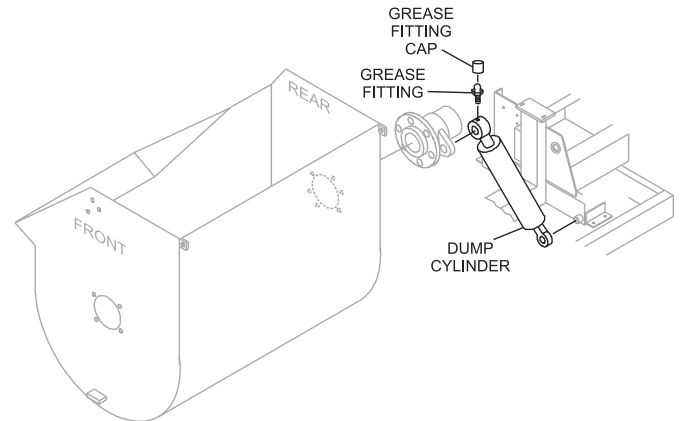

Figure 14. Grease Fittings (Dump Cylinder)

BLADE CHECK

Check for worn or paddle blades. Make sure that all blades are adjusted properly. See blade adjustment procedure in this manual. Replace all defective or damaged blades immediately.

DUMP HANDLE (MANUAL DUMP MACHINES ONLY)

Before operating a manual dump mixer, ensure that the dump handle has been placed in the operating position. See Figure 15.

1. Remove and retain nuts (2) and bolts (2) that secure dump handle to the drum in towing position.
2. Place dump handle in operating position and re-install nuts and bolts to secure dump handle to drum.

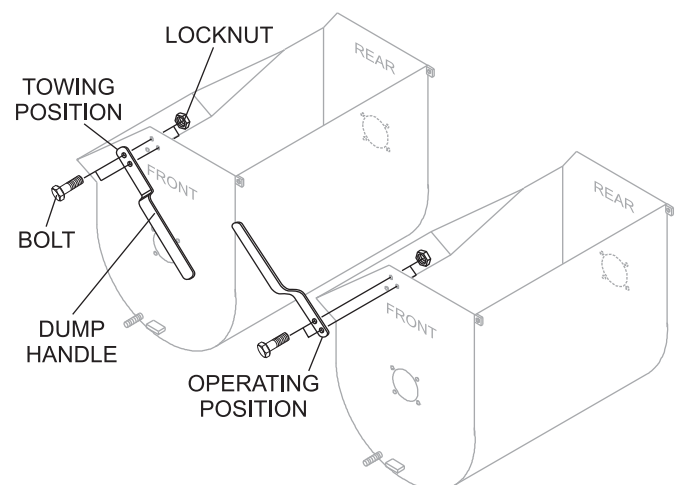

Figure 15. Dump Handle

INITIAL START-UP (GASOLINE)

STARTING THE ENGINE

The following steps outline the procedure for starting the engine. Depending on the type of engine employed in the mixer the steps may vary slightly. If your mixer has an electric motor disregard this section.

1. Place the fuel valve lever (Figure 16) in the **ON** position.

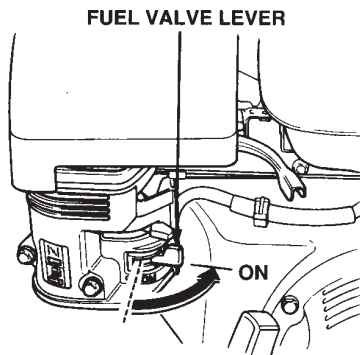

Figure 16. Fuel Shut-OFF Lever

2. To start a cold engine, move the choke lever (Figure 17) to the **CLOSED** position.

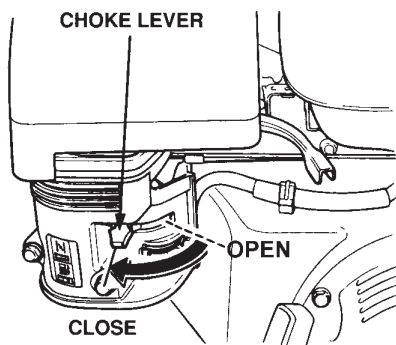

Figure 17. Choke Lever

3. Move the throttle lever (Figure 18) away from the slow position, about 1/3 of the way toward the fast position.

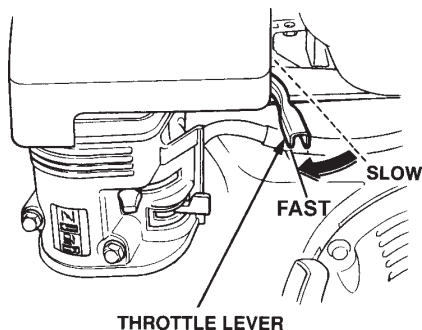

Figure 18. Throttle lever Lever

4. Place the engine ON/OFF switch (Figure 19) in the ON position position.

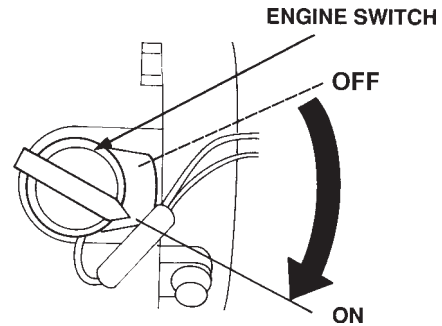

Figure 19. Engine ON/OFF Switch

5. Located on the engine cover is the **engine start/stop** switch (Figure 20). Pull this switch outward to start the engine.

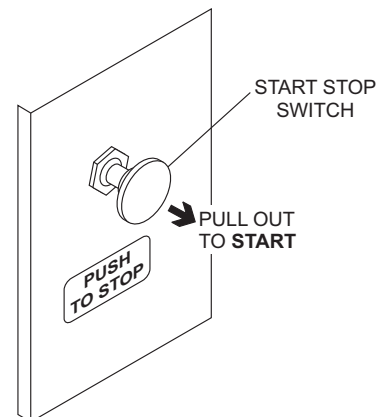

Figure 20. Main ON/OFF Switch

6. Pull the **starter grip** (Figure 21) lightly until you feel resistance, then pull briskly. Return the starter grip gently. Push the clutch lever forward, toward the tow tongue end of the mixer. When engine starts, adjust throttle lever so that paddle shaft inside mixer rotates between 30-40 RPMs. The number of RPMs will vary depending on engine type and load.

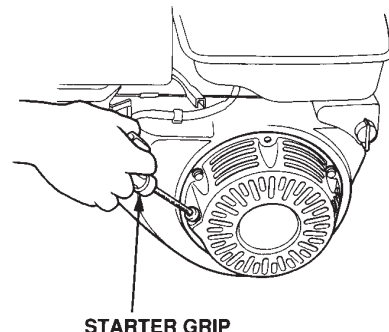

Figure 21. Starter Grip

INITIAL START-UP (ELECTRIC)/OPERATION

STARTING THE ELECTRIC MOTOR

- Using an adequate size extension cord (Table 7), connect one end of the extension cord to the plug on the electric motor, connect the other end to the power source. Make sure the motor is configured for the proper operating voltage.
- To start the electric motor, press the **black ON/START** switch (Figure 22).

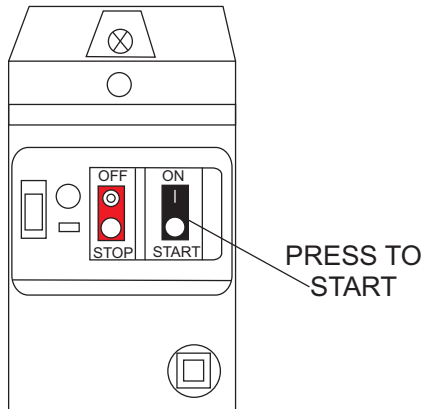

Figure 22. Electric Motor On/OFF Switch (Start)

Table 7. Load Ampere (Current) Rating (3Ø Extension)							
Cord Length ft (m)	0-2	2-5	5-7	7-10	10-12	12-15	15-20
10 ft (3.0 m)							12 ga
25 ft (7.6 m)	16 ga	16 ga	16 ga	16 ga	14 ga	14 ga	
50 ft (15.2 m)	16 ga	16 ga	16 ga	14 ga	14 ga	12 ga	
100 ft (30.5 m)	16 ga	16 ga	14 ga	12 ga	12 ga		
150 ft (45.7 m)	16 ga	14 ga	12 ga	12 ga			
200 ft (61.0 m)	14 ga	14 ga	12 ga	10 ga			

Extension cords must be rated "HEAVY DUTY" or "EXTRA-HEAVY DUTY" and must be a continuous length.

MIXING

- On the hydraulic valve, push lever inward (Figure 23) for clockwise mixing rotation of blades.
- The paddle shaft inside the drum should be rotating at this time.
- Add a small amount water to the mixing drum.
- Lift the mixing bag compound onto the steel safety grate over the bag cutter and let the contents fall into the drum. Add more water if desired and mix compound to desired consistency.

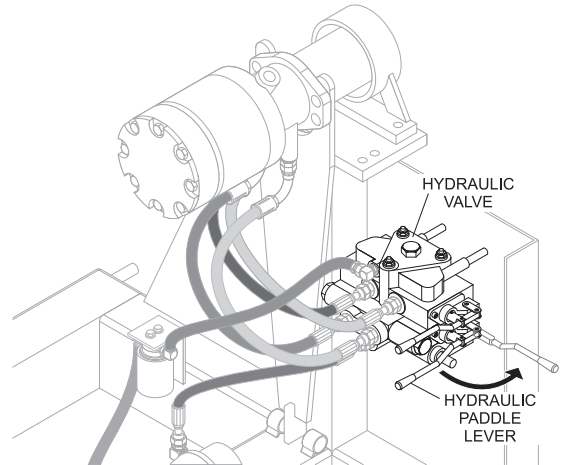

Figure 23. Hydraulic Paddle Lever

- Manual dump machines only: When mixing plaster or mortar, the **drum lock lever** (Figure 24) should be in the **horizontal (down)** position. (Does not apply to hydraulic dump mixers.)

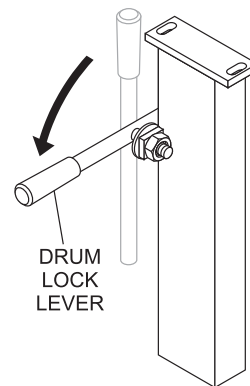

Figure 24. Drum Lock Lever



When the drum lock lever is placed horizontally, the drum will be maintained in the vertical position as the paddles rotate. This condition does not apply to models that have hydraulic dump capability.

WARNING — Dump Handle Safety

ALWAYS stand clear of the **dump handle** when the mixer is operational. Any binding of material between the mixer blades and the drum will cause the drum handle to quickly move and could cause severe bodily harm.



DUMPING (MANUAL)

1. Release drum lock lever by pushing lever into **vertical** position (Figure 25).

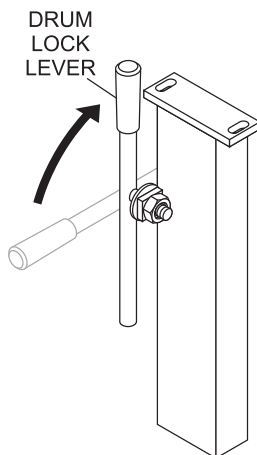

Figure 25. Drum Lock Lever

2. Pull dump handle downward to discharge (empty) the drum. Move dump handle upward to return it to vertical position. (Figure 26).

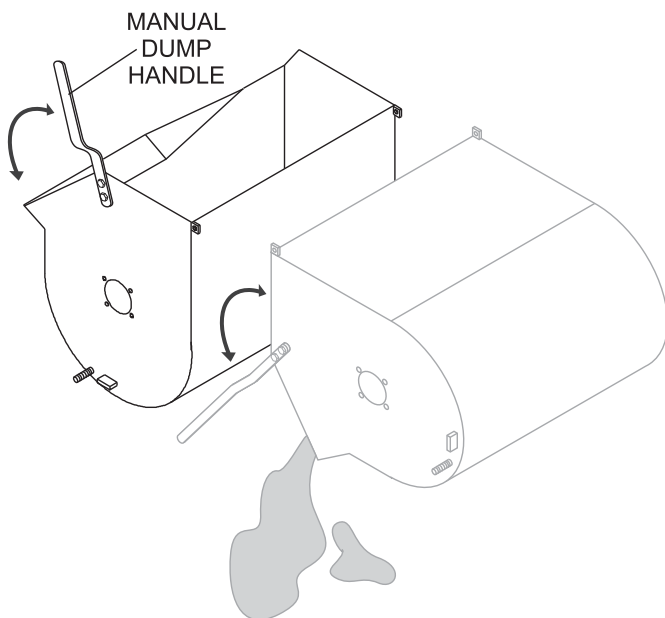

Figure 26. Manual Dump Handle

3. Drum lock lever automatically moves back to horizontal position, locking the drum back into vertical position.
4. Inspect for proper functionality before starting the engine or engaging blades. Any binding of material between the mixing blades and drum will cause the handle to quickly rotate if not in the “up and locked” position.

DUMPING (HYDRAULIC)

1. If operating a mixer with hydraulic dump capability, pull hydraulic dump lever (Figure 27) outward to place drum in dump position (Figure 28).

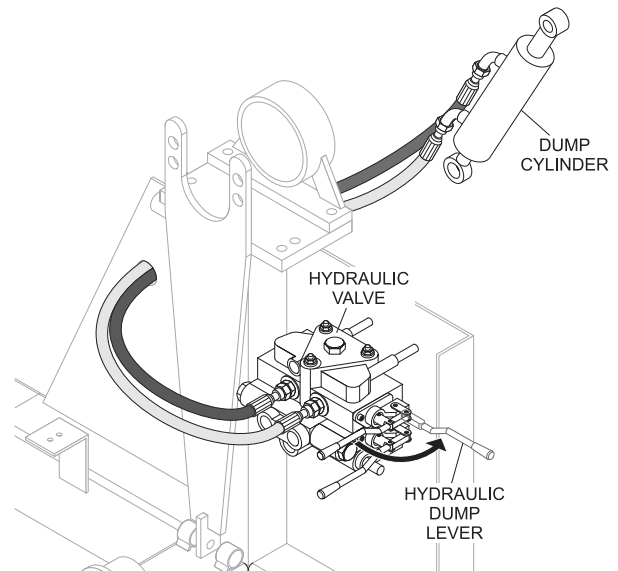

Figure 27. Hydraulic Dump Lever

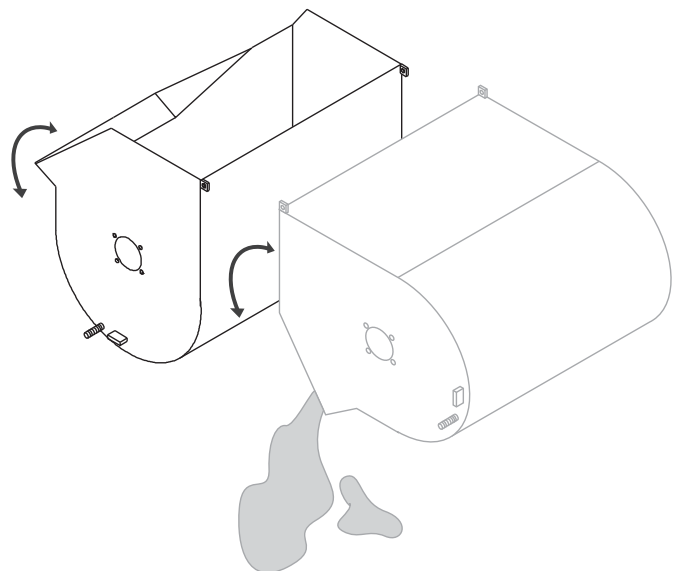

Figure 28. Hydraulic Dump

2. Push hydraulic dump lever inward to place drum back in vertical position.

STOPPING THE MIXER (GASOLINE ENGINE)

1. Push the **start/stop** switch (Figure 29) inward to stop the engine.

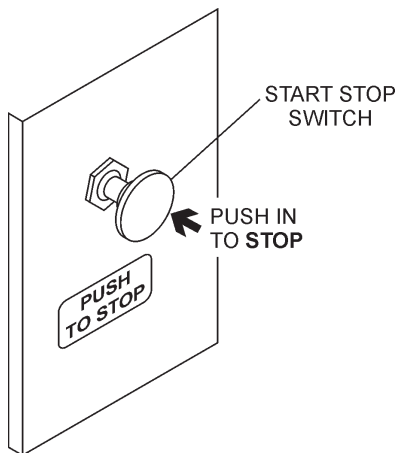

Figure 29. Start/Stop Switch (Stop)

2. Place the fuel valve (Figure 30) lever to the **OFF** position.

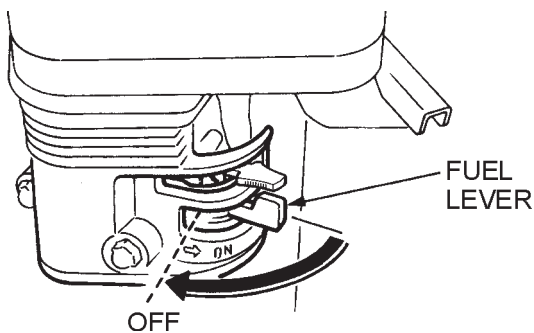

Figure 30. Fuel Valve Lever (Off)

3. Clean mixer as referenced in the maintenance section of this manual.

STOPPING THE MIXER (ELECTRIC MOTOR)

1. To stop the electric motor, press the **red OFF/STOP** switch (Figure 31).

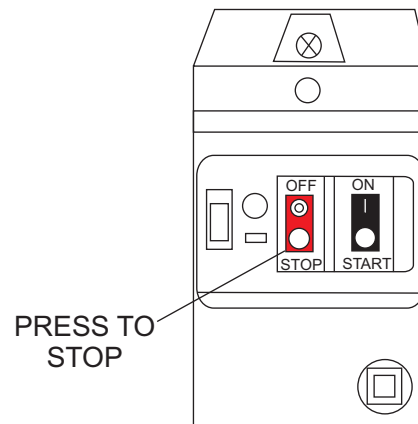

Figure 31. Electric Motor On/OFF Switch (Stop)

2. Disconnect the electric motor's extension cord from its power source.
3. Clean mixer as referenced in the maintenance section of this manual.

CAUTION —Start/Stop Switch

NEVER disable or disconnect the start/stop switch. It is provided for operator safety. **Serious Injury** may result if it is disabled, disconnected or improperly maintained.

MAINTENANCE (ENGINE)

Use Table 8 as a general maintenance guideline when servicing your engine. For more detail engine maintenance information, refer to the engine owner's manual supplied with your engine.

TABLE 8. ENGINE MAINTENANCE SCHEDULE							
DESCRIPTION (3)	OPERATION	BEFORE	FIRST MONTH OR 10 HRS.	EVERY 3 MONTHS OR 25 HRS.	EVERY 6 MONTHS OR 50 HRS.	EVERY YEAR OR 100 HRS.	EVERY 2 YEARS OR 200 HRS.
Engine Oil	CHECK	X					
	CHANGE		X			X	
Air Cleaner	CHECK	X					
	CHANGE			X (1)			
All Nuts & Bolts	Re-tighten If Necessary	X					
Spark Plug	CHECK-CLEAN				X		
	REPLACE						X
Cooling Fins	CHECK				X		
Spark Arrester	CLEAN					X	
Fuel Tank	CLEAN					X	
Fuel Filter	CHECK					X	
Idle Speed	CHECK-ADJUST					X (2)	
Valve Clearance	CHECK-ADJUST						X (2)
Fuel lines	CHECK	Every 2 years (replace if necessary) (2)					

(1) Service more frequently when used in **DUSTY** areas.

(2) These items should be serviced by your service dealer, unless you have the proper tools and are mechanically proficient. Refer to the HONDA Shop Manual for service procedures.

(3) For commercial use, log hours of operation to determine proper maintenance intervals.

MAINTENANCE (ENGINE)

MAINTENANCE

Perform the scheduled maintenance procedures as defined by Table 8 and below:

Daily

■ Thoroughly remove dirt and oil from the engine and control area. Clean or replace the air cleaner elements as necessary. Check and retighten all fasteners as necessary. Check the gearbox for oil leaks. Repair or replace as needed.

Weekly

■ Remove the fuel filter cap and clean the inside of the fuel tank.

■ Remove or clean the filter at the bottom of the tank.

■ Remove and clean the spark plug (Figure 32), then adjust the spark gap to 0.024 ~0.028 inch (0.6~0.7 mm). This unit has electronic ignition, which requires no adjustments.

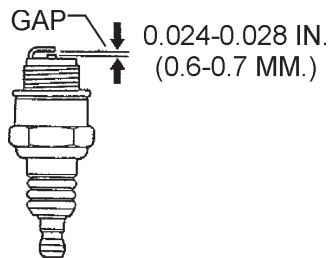

Figure 32. Spark Plug Gap

ENGINE OIL

1. Drain the engine oil when the oil is **warm** as shown in Figure 33.

2. Remove the oil drain bolt and sealing washer and allow the oil to drain into a suitable container.

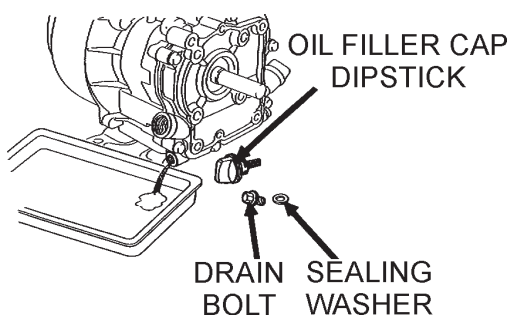

Figure 33. Engine Oil (Draining)

3. Replace engine oil with recommended type oil as listed in Table 6. For engine oil capacity, see Table 2 (engine specifications). **DO NOT** overfill.

4. Install drain bolt with sealing washer and tighten securely.

ENGINE AIR CLEANER

1. Remove the air cleaner cover and foam filter element as shown in Figure 34.

2. Tap the paper filter element (Figure 34) several times on a hard surface to remove dirt, or blow compressed air [not exceeding 30 psi (207 kPa, 2.1 kgf/cm²)] through the filter element from the air cleaner case side. **NEVER** brush off dirt. Brushing will force dirt into the fibers. Replace the paper filter element if it is excessively dirty.

3. Clean foam element in warm, soapy water or nonflammable solvent. Rinse and dry thoroughly. Dip the element in clean engine oil and completely squeeze out the excess oil from the element before installing.

⚠ DANGER — Explosive Hazard

DO NOT use gasoline as a cleaning solvent to avoid creating the risk of fire or an explosion.

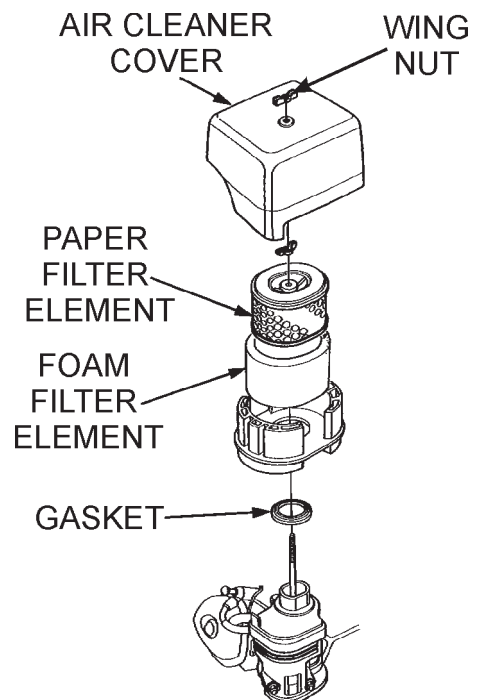

Figure 34. Engine Air Cleaner

MAINTENANCE (MIXER)

DRUM HEAD SEALS

There is 1 set of drum head seals (Figure 35) that will require lubrication. Lubricate the grease fitting for each drum seal **after each use** using any grade lithium base grease. Apply grease until visible inside of mixing drum (over grease). This will purge seal system of contamination.

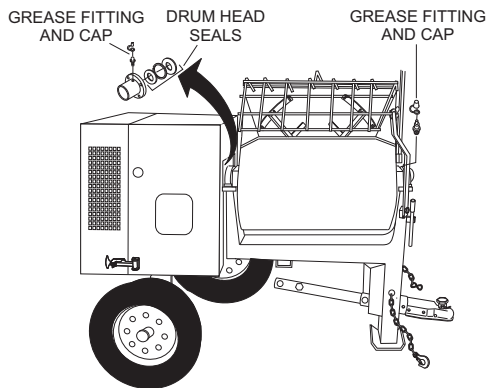

Figure 35. Grease Fittings (Drum Head Seals)

DRUM BEARING BRACKET LUBRICATION

There is 1 set of drum bearing brackets (Figure 36) that will require lubrication. These brackets are intended to make the drum rotate freely. Lubricate the grease fitting for each drum bearing bracket **every month or when the drum becomes difficult to position** using multi-purpose grade grease.

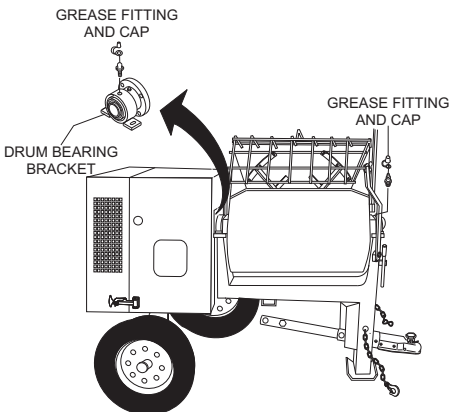

Figure 36. Grease Fittings (Dumping Mechanism)

CAUTION — Lubricate Grease Fittings

Failure to lubricate the drum bearing grease fittings eriodically will cause the dumping mechanism to stiffen, making the mixing drum hard to dump.

BALL SOCKET AND CLAMP FACE MAINTENANCE

1. If the towing vehicle is equipped with a ball socket, smear socket periodically with multi-purpose grease. This will keep the ball socket well lubricated.
2. Periodically oil **pivot points** and **clamp face** surfaces of coupler with SAE 30 WT. motor oil.
3. When parking or storing your mixer. Keep the coupler off the ground so dirt will not build up in the ball socket.

HYDRAULIC OIL FILTER

Replace hydraulic oil filter (Figure 37) every 500 hours. Hydraulic tank capacity is 12 gallons (45 liters). Refill with any of the following hydraulic oil types. Shell Tellius 68, Mobil DFE26 or Texaco Rand HDC.

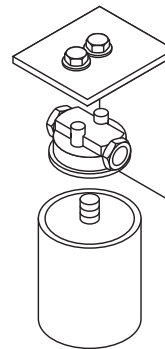

Figure 37. Hydraulic Oil Filter

WHEEL BEARINGS

1. After every 3 months of operation, remove the hub dust cap and inspect the wheel bearings (Figure 38). Once a year, or when required, disassemble the wheel hubs remove the old grease and repack the bearings forcing grease between rollers, cone and cage with a good grade of high speed wheel bearing grease (**never** use grease heavier than 265 A.S.T.M. penetration (“No. 2.”)

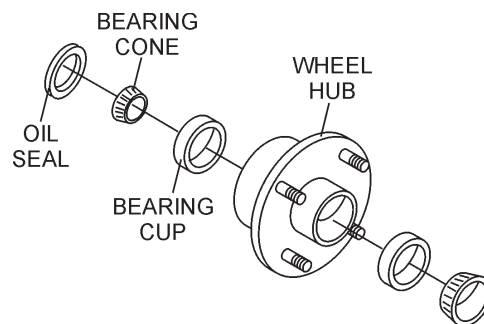

Figure 38. Wheel Hub and Bearings

MAINTENANCE (MIXER)

TIRES/WHEELS/LUG NUTS

Tires and wheels are a very important and critical components of the trailer. When specifying or replacing the trailer wheels it is important the wheels, tires, and axle are properly matched.

⚠ WARNING — Damaged Wheels

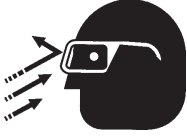

DO NOT attempt to repair or modify a wheel. **DO NOT** install an inter-tube to correct a leak through the rim. If the rim is cracked, the air pressure in the inter-tube may cause pieces of the rim to explode (break-off) with great force and can cause serious eye or bodily injury.

TIRES WEAR/INFLATION







Tire inflation pressure is the most important factor in tire life. Pressure should be checked cold before operation. **DO NOT** bleed air from tires when they are hot. Check inflation pressure weekly during use to insure the maximum tire life and tread wear.

⚠ WARNING — Eyesight Hazard



ALWAYS wear safety glasses when removing or installing force fitted parts. Failure to comply may result in serious injury.

Table 9 (Tire Wear Troubleshooting) will help pinpoint the causes and solutions of tire wear problems.

TABLE 9. TIRE WEAR TROUBLESHOOTING			
WEAR PATTERN	CAUSE	SOLUTION	
 Center Wear	Over Inflation	Adjust pressure to particular load per tire manufacturer.	
 Edge Wear	Under Inflation	Adjust pressure to particular load per tire manufacturer.	
 Side Wear	Loss of chamber or overloading.	Make sure load does not exceed axle rating. Align wheels.	
 Toe Wear	Incorrect toe-in	Align wheels.	
 Cupping	Out-of balance	Check bearing adjustment and balance tires.	
 Flat Spots	Wheel lockup & tire skidding.	Avoid sudden stops when possible and adjust brakes.	

LUG NUT TORQUE REQUIREMENTS

It is extremely important to apply and maintain proper wheel mounting torque. Be sure to use only the fasteners matched to the cone angle of the wheel. Proper procedure for attachment of the wheels is as follows:

1. Start all wheel lug nuts by hand.
2. Torque all lug nuts in sequence. See Figure 39. **DO NOT** torque the wheel lug nuts all the way down. Tighten each lug nut in 3 separate passes as defined by Table 10.

TABLE 10. TIRE TORQUE REQUIREMENTS			
Wheel Size	First Pass FT-LBS	Second Pass FT-LBS	Third Pass FT-LBS
12"	20-25	35-40	50-65
13"	20-25	35-40	50-65
14"	20-25	50-60	90-120
15"	20-25	50-60	90-120
16"	20-25	50-60	90-120



NEVER! use an pneumatic air gun to tighten wheel lug nuts.

MAINTENANCE (MIXER)

- After first road use, retorque all lug nuts in sequence. Check all wheel lug nuts periodically.

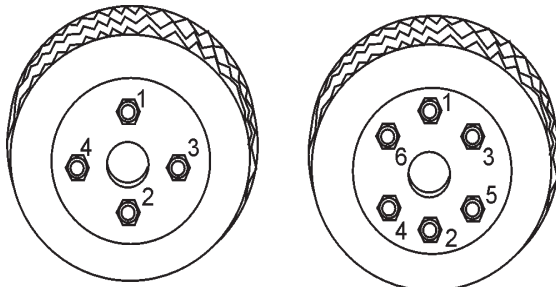

4-LUG NUTS

6-LUG NUTS

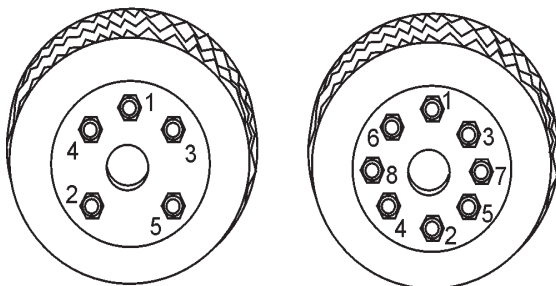

5-LUG NUTS

8-LUG NUTS

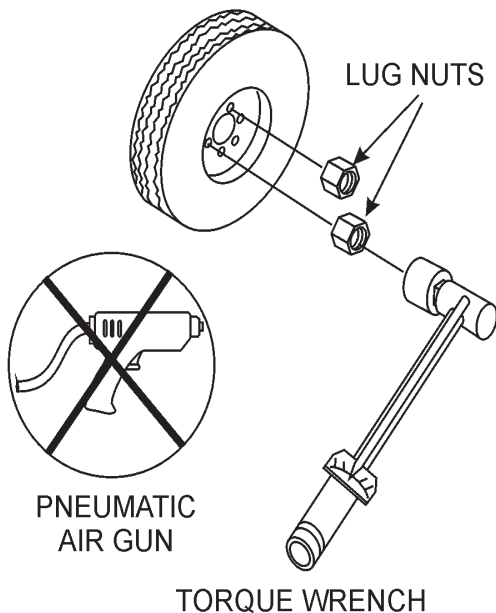

Figure 39. Wheel Lug Nuts Tightening Sequence

SUSPENSION

The suspension type axle and associated hardware (Figure 40) should be periodically inspected for signs of excessive wear, elongation of bolt holes, and loosening of fasteners. Replace all damaged parts immediately.

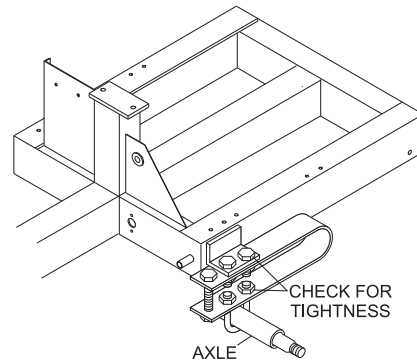

Figure 40. Axle Support Components

MIXER CLEANING

It is important that the drum interior is free of dried material. Obstructions can cause the paddle blades to lock against the drum resulting in sudden dump handle movement.

- Stop the engine. Push the engine "Kill" button to the "OFF" position.
- Place the hydraulic paddle lever (Figure 5) in "neutral" position do disengage.
- ALWAYS disconnect the spark plug wire** (gasoline engines) before cleaning the inside of the drum. If mixer is equipped with an electric motor **remove power cord from AC power source**. In addition make sure the clutch engagement lever is **disengaged**.
- Place "Do Not Operate" tag on mixer.
- Make sure the rear section of safety grate is connected to the mixing drum.
- At the end of each day's operation, place mixer drum in an upright position and spray inside of tub immediately with water to prevent lumps of dried mortar or plaster from forming and contamination of future batches, **DO NOT** allow a buildup of materials to form on the blades or anywhere inside the drum.
- Rotate mixer to dump position and remove debris.
- Thoroughly clean** the entire mixer, wheels, cabinet and frame.

MAINTENANCE (MIXER)/STORAGE

9. **NEVER!** pour or spray water over the engine or electric motor (Figure 41).

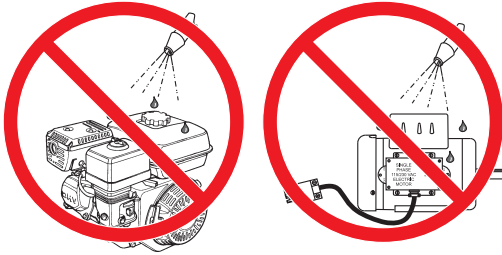

Figure 41. No Spraying of Water

10. When cleaning of the entire mixer is done, return mixing drum to an upright position.

WARNING — Keep Hands Clear of Drum

When rotating the mixing drum from the dump position to the upright position, **keep hands clear of safety grate**. The possibility exists of hands or fingers being crushed (Figure 42).



Figure 42. Safety Grate (Crush Hazard)

WARNING — Disengaged Drum Lock

DO NOT start engine or engage paddle arms when drum lock lever is not engaged.

MIXER STORAGE

For storage of the mixer for over 30 days, the following is recommended:

- Drain the fuel tank completely, or add STA-BIL to the fuel.
- **Run the engine until the fuel is completely consumed.**
- Completely drain used oil from the engine crankcase and fill with fresh clean oil, then follow the procedures described in the engine manual for engine storage.
- Clean the entire mixer and engine compartment.
- Place the mixing drum in the down position (mouth facing downward).
- Cover the mixer and place it a clean dry area, that is protected from harsh elements.

TROUBLESHOOTING (ENGINE)

Practically all breakdowns can be prevented by proper handling and maintenance inspections, but in the event of a breakdown, please take a remedial action following the diagnosis based on the *Engine, Mixer* and *Electric Motor* Troubleshooting (Tables 11,12, and 13) information shown below and on the proceeding pages. If the problem cannot be remedied, please leave the unit just as it is and consult or company's service department.

TABLE 11. ENGINE TROUBLESHOOTING

SYMPTOM	POSSIBLE PROBLEM	SOLUTION
Poor starting	Inspect carburetor to see if fuel is reaching it?	Check fuel line
	No Fuel?	Add Fuel
	Water in fuel tank?	Flush or replace fuel tank.
	Fuel filter clogged?	Replace fuel filter
	Stuck carburetor?	Check float mechanism.
	Spark plug is red?	Spark plug is fouled. Check transistor ignition unit.
	Spark plug is blue-white?	Insufficient compression, injected air leaking. Carburetor jets are clogged (overflow).
	No spark present at tip of spark plug?	Transistor ignition unit broken, high voltage cord cracked or broken. Start/Stop switch broken. Replace spark plug if fouled.
	No oil?	Add oil as required.
	Oil pressure alarm lamp blinks upon starting?	Check Automatic shutdown circuit "oil sensor".
Insufficient power output "no compression"	Engine will not turn over?	Replace cylinder and piston and if necessary axel joint.
	Cylinder head connecting bolts loose?	Tighten cylinder head connecting bolts.
	Cylinder head gasket damaged?	Replace cylinder head gasket.
	Malfunction of valve seat?	Re-seat valves.
	Spark plug is loose?	Replace spark plug.
	Worn piston rings?	Replace piston rings.
Insufficient power output "compression"	Malfunction in air-cleaner system, air filter clogged?	Clean or replace air filter.
	Air leaking in from interface between carburetor and cylinder head?	Tighten bolts between carburetor and cylinder head. Replace cylinder head gasket.
	Malfunction in fuel system?	Clean or replace fuel filter. Clean or replace carburetor. Check carburetor float.

TROUBLESHOOTING (ENGINE)

TABLE 11. ENGINE TROUBLESHOOTING (CONTINUED)

SYMPTOM	POSSIBLE PROBLEM	SOLUTION
Insufficient power output "compression" and overheats	Malfunction in cooling fan?	Check or replace cooling fan.
	Air in-take filter clogged?	Clean or replace air in-take filter.
Burns to much fuel	Over accumulation of exhaust products?	Clean and check valves. Check muffler, replace if necessary.
	Wrong spark plug?	Replace spark plug with manufactures suggested type spark plug.
Exhaust color is continously "WHITE"	Lubricating oil is wrong viscosity?	Replace lubricating oil with correct viscosity.
	Worn rings?	Replace rings
Exhaust color is continously "BLACK"	Air cleanner clogged?	Clean or replace air cleaner.
	Choke valve has not been set to the correct position?	Adjust choke valve to the correct position.
	Carburetor defective, seal on carburetor broken?	Replace carburetor or seal.
	Poor carburetor adjustment "engine runs too rich?"	Adjust carburetor.

TROUBLESHOOTING (MIXER/ELECTRIC MOTOR)

TABLE 12. MIXER TROUBLESHOOTING

SYMPTOM	POSSIBLE PROBLEM	SOLUTION
Blades will not rotate.	Material load too heavy, exceeding mixer capability?	Reduce amount of material being mixed.
	Object stuck inside mixing drum, jamming paddle rotation?	Stop engine. Empty out drum contents. Remove obstruction.
	Incorrect relief valve pressure?	Inspect for proper 1750 PSI relief pressure.
	Check engine speed.	Proper RPM 3600.
	Defective hydraulic motor or pump?	Contact MQ Technical Services.
	Slow hydraulic cylinder dumping?	Defective cylinder seal.
Material leaking from drum ends.	Worn or defective paddle shaft seals?	Replace seals.
Drum difficult to discharge (tilt)	Defective or worn drum support brackets?	Apply grease to bracket or replace.
	Blades adjusted too tight.	Adjust blades until they almost touch side walls of drum.

TABLE 13. ELECTRIC MOTOR TROUBLESHOOTING

SYMPTOM	POSSIBLE PROBLEM	SOLUTION
Blades will not rotate.	No voltage to motor?	Check power source.
	Defective extension cord?	Replace extension cord.
	Defective motor ON/OFF switch?	Replace switch.
	Defective motor windings?	Repair windings or replace windings.

WIRING DIAGRAM (ELECTRIC MOTOR)

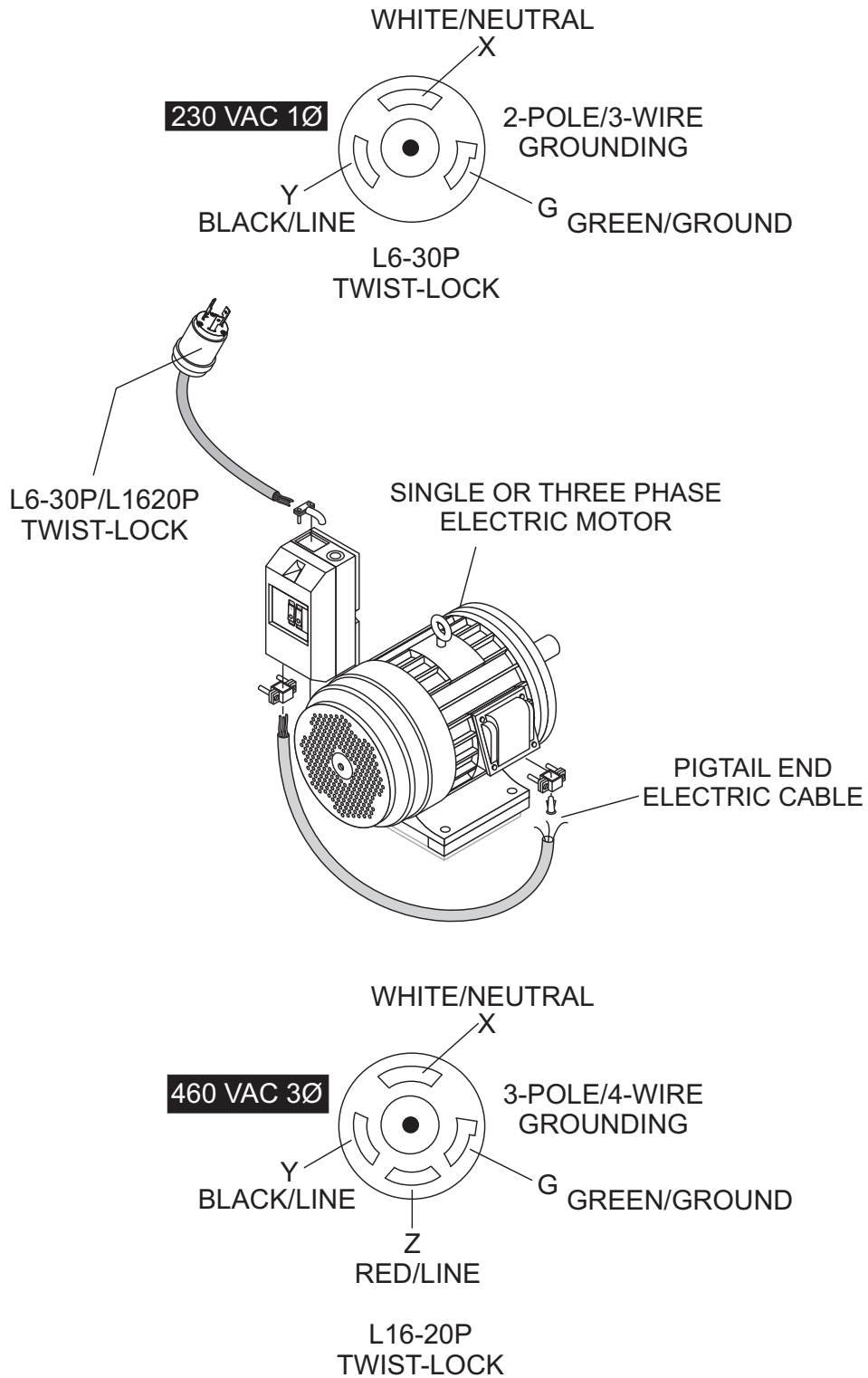
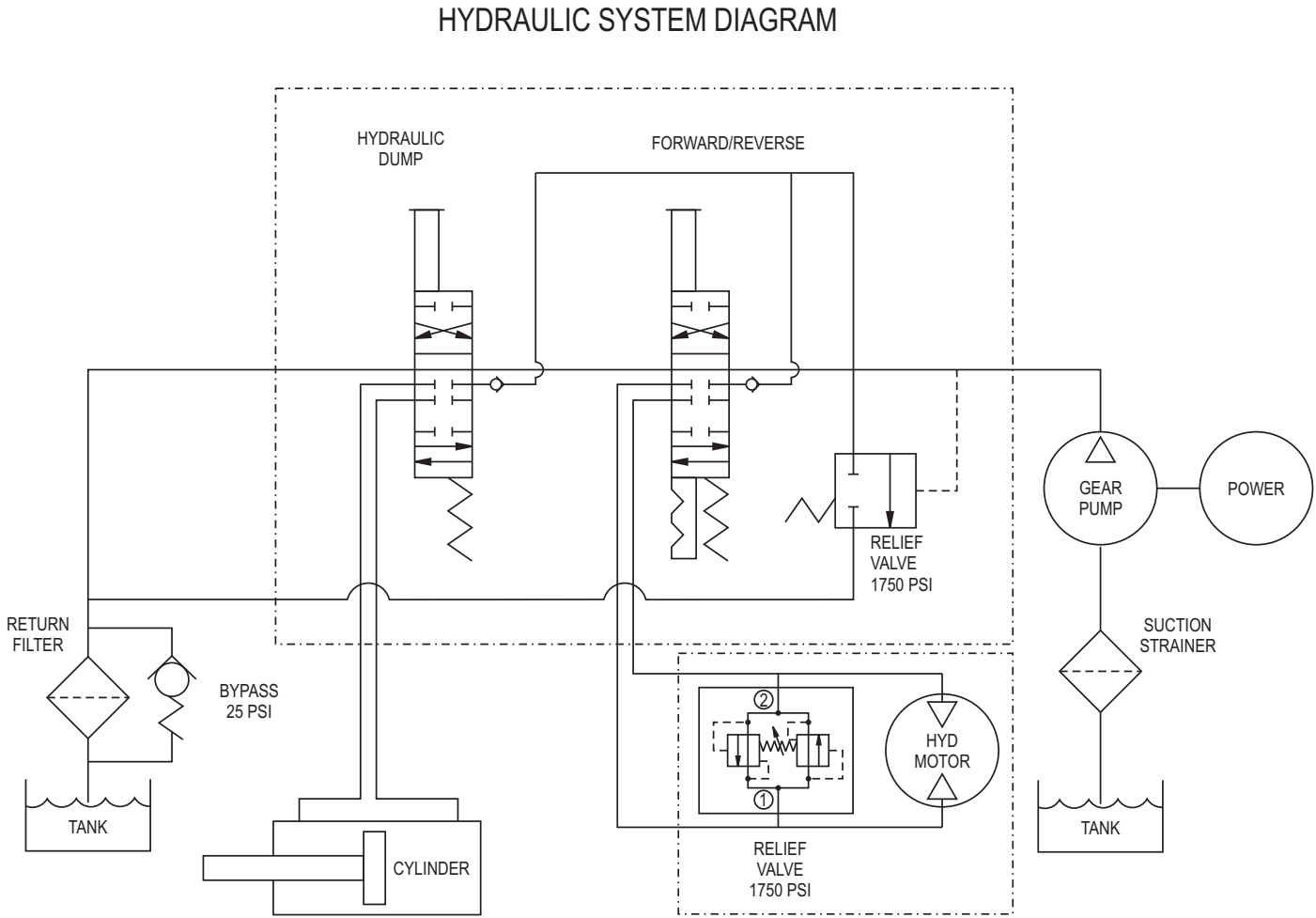

Figure 43. Electric Motor Wiring Diagram

HYDRAULIC SYSTEM DIAGRAM



SHOWN WITH OPTIONAL HYDRAULIC DUMP

Figure 44. Hydraulic System Diagram

EXPLANATION OF CODE IN REMARKS COLUMN

The following section explains the different symbols and remarks used in the Parts section of this manual. Use the help numbers found on the back page of the manual if there are any questions.

NOTICE

The contents and part numbers listed in the parts section are subject to change **without notice**. Multiquip does not guarantee the availability of the parts listed.

SAMPLE PARTS LIST

NO.	PART NO.	PART NAME	QTY.	REMARKS
1	12345	BOLT.....	1	INCLUDES ITEMS W/%
2%		WASHER, 1/4 IN.....		NOT SOLD SEPARATELY
2%	12347	WASHER, 3/8 IN.....	1	MQ-45T ONLY
3	12348	HOSE	A/R	MAKE LOCALLY
4	12349	BEARING	1	S/N 2345B AND ABOVE

NO. Column

Unique Symbols — All items with same unique symbol

(@, #, +, %, or >) in the number column belong to the same assembly or kit, which is indicated by a note in the “Remarks” column.

Duplicate Item Numbers — Duplicate numbers indicate multiple part numbers, which are in effect for the same general item, such as different size saw blade guards in use or a part that has been updated on newer versions of the same machine.

NOTICE

When ordering a part that has more than one item number listed, check the remarks column for help in determining the proper part to order.

PART NO. Column

Numbers Used — Part numbers can be indicated by a number, a blank entry, or TBD.

TBD (To Be Determined) is generally used to show a part that has not been assigned a formal part number at the time of publication.

A blank entry generally indicates that the item is not sold separately or is not sold by Multiquip. Other entries will be clarified in the “Remarks” Column.

QTY. Column

Numbers Used — Item quantity can be indicated by a number, a blank entry, or A/R.

A/R (As Required) is generally used for hoses or other parts that are sold in bulk and cut to length.

A blank entry generally indicates that the item is not sold separately. Other entries will be clarified in the “Remarks” Column.

REMARKS Column

Some of the most common notes found in the “Remarks” Column are listed below. Other additional notes needed to describe the item can also be shown.

Assembly/Kit — All items on the parts list with the same unique symbol will be included when this item is purchased.

Indicated by:

“INCLUDES ITEMS W/(unique symbol)”

Serial Number Break — Used to list an effective serial number range where a particular part is used.

Indicated by:

“S/N XXXXX AND BELOW”

“S/N XXXX AND ABOVE”

“S/N XXXX TO S/N XXX”

Specific Model Number Use — Indicates that the part is used only with the specific model number or model number variant listed. It can also be used to show a part is NOT used on a specific model or model number variant.

Indicated by:

“XXXXX ONLY”

“NOT USED ON XXXX”

“Make/Obtain Locally” — Indicates that the part can be purchased at any hardware shop or made out of available items. Examples include battery cables, shims, and certain washers and nuts.

“Not Sold Separately” — Indicates that an item cannot be purchased as a separate item and is either part of an assembly/kit that can be purchased, or is not available for sale through Multiquip.

SUGGESTED SPARE PARTS

WM120PS 1 TO 3 UNITS

Qty.	P/N	Description
6	491010	RUBBER LATCH ASSY.
1	EM200293A	PADDLE ARM TOW SIDE
1	EM200294A	PADDLE ARM CENTER TOW SIDE
1	EM200295A	PADDLE ARM CENTER ENGINE SIDE
1	EM200296A	PADDLE ARM ENGINE SIDE
3	EM200863	RUBBER BLADE KIT (STEEL DRUM)
3	EM204625	RUBBER BLADE KIT (PLASTIC DRUM)
4	EM200297	U-BOLT
2	3530	PADDLE SHAFT, SEAL KIT
2	EM902153	BEARING, PADDLE SHAFT

WM120PS 5 TO 10 UNITS

Qty.	P/N	Description
10	491010	RUBBER LATCH ASSY.
2	EM200293A	PADDLE ARM TOW SIDE
2	EM200294A	PADDLE ARM CENTER TOW SIDE
2	EM200295A	PADDLE ARM CENTER ENGINE SIDE
2	EM200296A	PADDLE ARM ENGINE SIDE
6	EM200863	RUBBER BLADE KIT (STEEL DRUM)
3	EM204625	RUBBER BLADE KIT (PLASTIC DRUM)
16	EM200297	U-BOLT
4	3530	PADDLE SHAFT, SEAL KIT
4	EM902153	BEARING, PADDLE SHAFT

NAMEPLATE AND DECALS

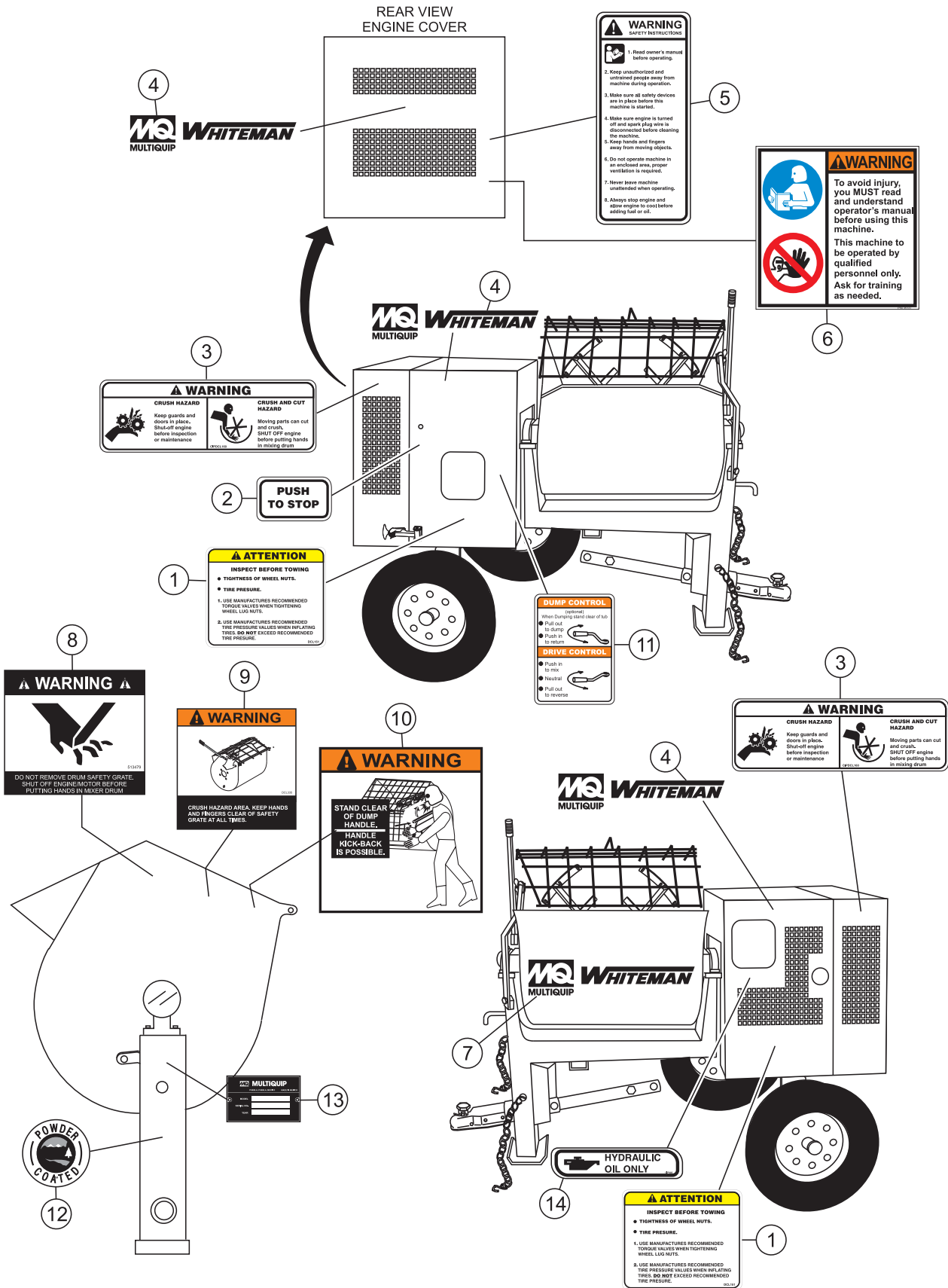

NAMEPLATE AND DECALS

<u>NO.</u>	<u>PART NO.</u>	<u>PART NAME</u>	<u>QTY.</u>	<u>REMARKS</u>
1	DCL151	DECAL, TOWING INSTRUCTIONS	2	
2	EM948630	DECAL, PUSH TO STOP	1	
3	DCL160A	DECAL, CRUSH WARNING	2	
4	515275	DECAL, WHITEMAN LOGO (SMALL)	3	
5	504713	DECAL, SAFETY INSTRUCTIONS	1	
6	35137	DECAL, WARNING READ	1	
7	504714	DECAL, WHITEMAN LOGO (LARGE)	3	
8	513479	DECAL, WARNING SAFETY GRATE	1	
9	DCL335	DECAL, CRUSH WARNING SAFETY GRATE	1	
10	DCL280	DECAL, WARNING DUMP HANDLE	1	
11	13238	DECAL, CONTROLS, MOLD-IN	1	
12	13118	DECAL, POWDER COATED	1	
13		NAMEPLATE.....	1 CONTACT PARTS DEPT.

PADDLE BLADES ASSY.

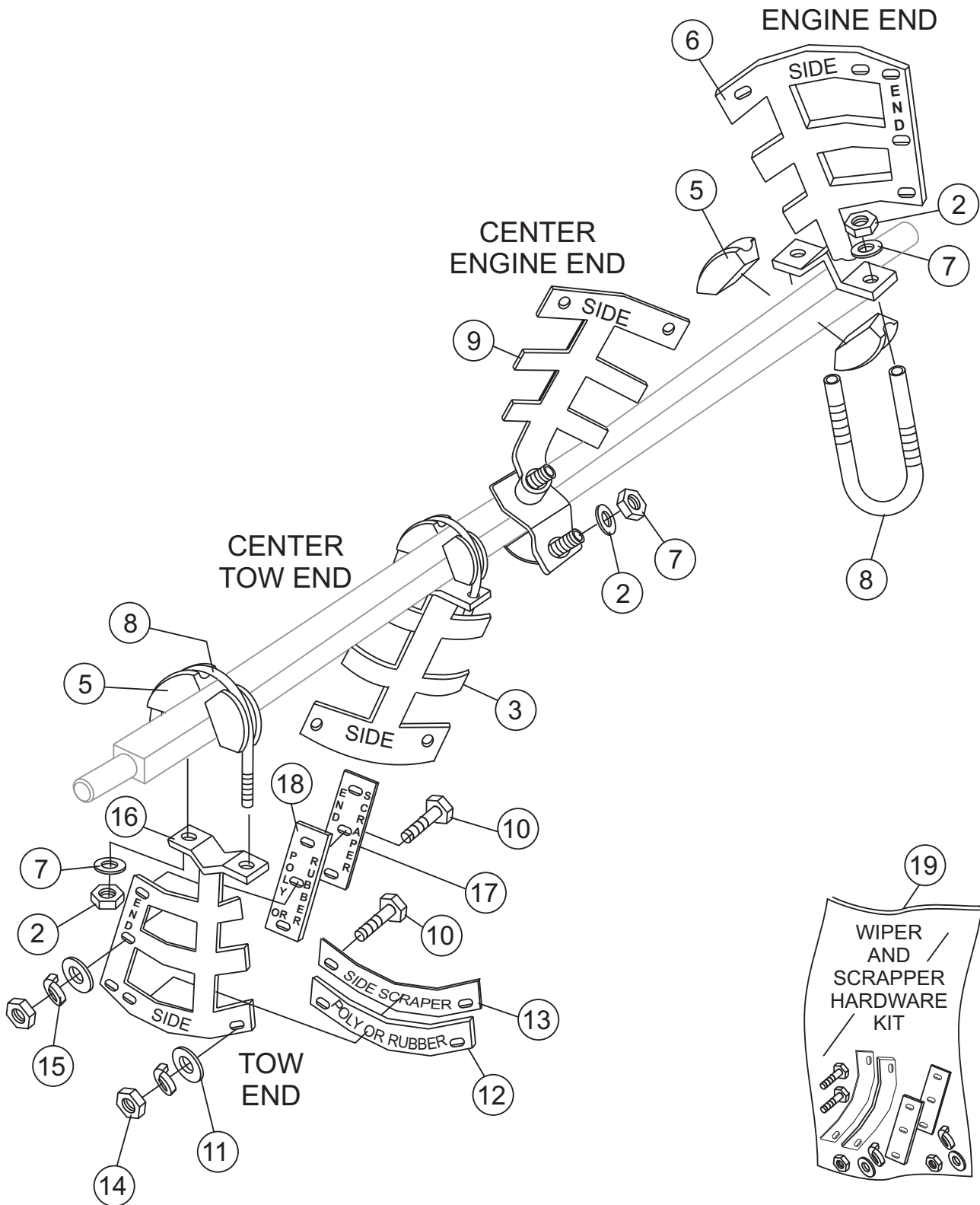

PADDLE BLADES ASSY.

<u>NO.</u>	<u>PART NO.</u>	<u>PART NAME</u>	<u>QTY.</u>	<u>REMARKS</u>
2	492584	NUT, LOCK 1/2"	8	
3	EM200295A	PADDLE ARM, CENTER TOW END	1	
5	EM200292	INSERT, PADDLE ARM	8	
6	EM200293A	PADDLE ARM, TOW END	1	
7	6109170	WASHER, FLAT 1/2"	8	
8	EM200297	U-BOLT, END PADDLES	4	
9	EM200294A	PADDLE ARM, CENTER ENGINE END	1	
10*#	492366	SCREW, HHC 5/16-18 X 1-1/2 G5	14	
11*#	EM923023	WASHER, FLAT 5/16" STEEL	28	
12#	13352	WIPER, SIDE (PLASTIC)	4	PLASTIC DRUM
12*	EM200212	WIPER, SIDE (RUBBER)	4	STEEL DRUM
13*#	EM203432	SCRAPPER, SIDE	4	PLASTIC/STEEL DRUMS
14*#	2105164	NUT, HEX 5/16"	14	
15*#	EM923343	WASHER, LOCK 5/16"	14	
16	EM200296A	PADDLE ARM, ENGINE END	1	
17*	EM203433	SCRAPPER, END	2	PLASTIC/STEEL DRUMS
18#	EM507518	BLADE, PLASTIC (END)	2	PLASTIC DRUM
18*	EM200213	BLADE, RUBBER (END)	2	STEEL DRUM
19	EM200863	KIT, RUBBER BLADES, SCRAPERS & HARDWARE	1	INCLUDES ITEMS W/*
			STEEL DRUM ONLY
19	EM204625	KIT, PLASTIC BLADES, SCRAPERS & HARDWARE	1	INCLUDES ITEMS W/#
			PLASTIC DRUM ONLY

PLASTIC MIXING DRUM ASSY.

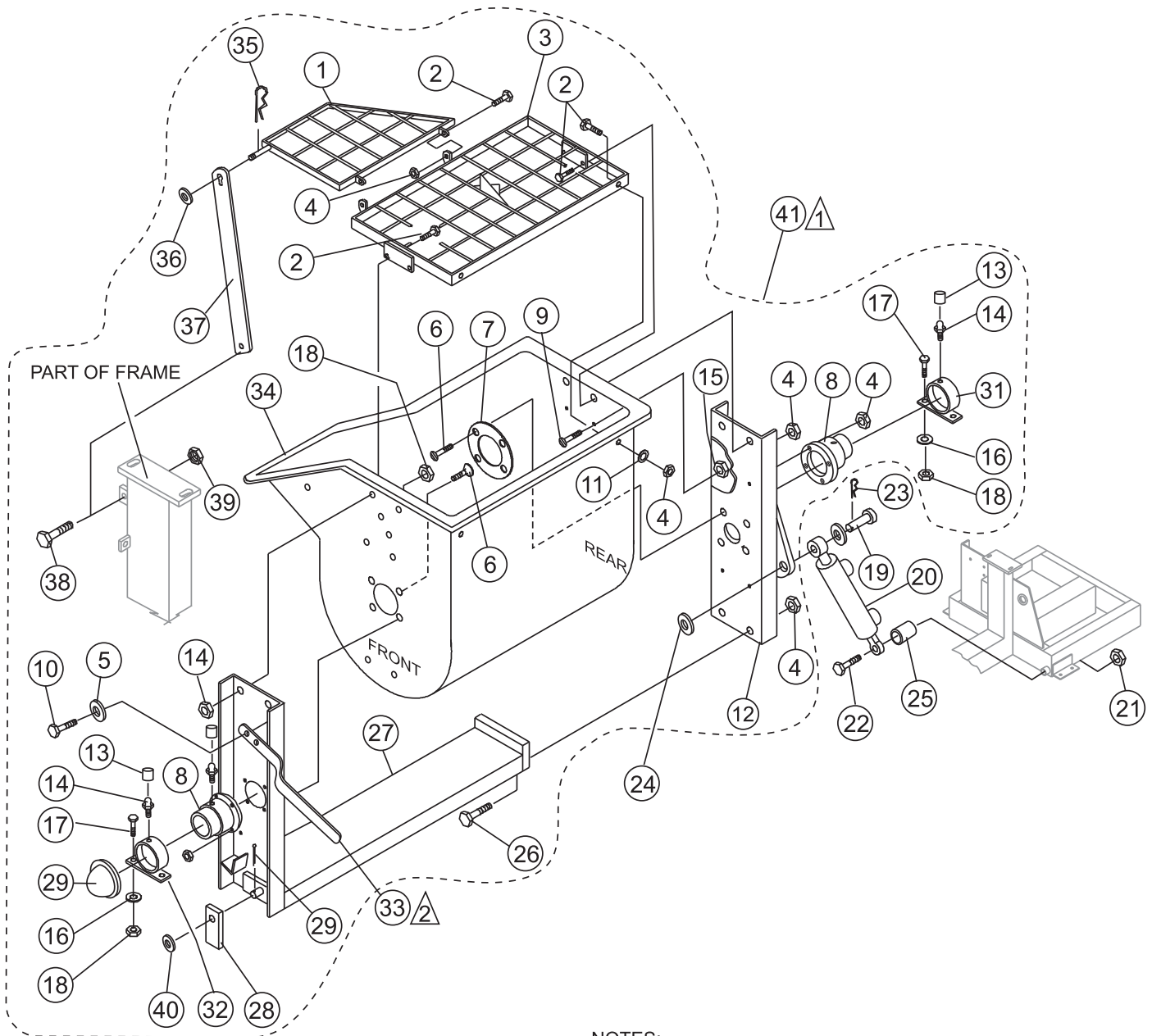

NOTES:

COMPLETE DRUM ASSEMBLY INCLUDES
 △ 1 ITEMS WITHIN DASHED LINE. ALSO
 INCLUDED ARE PADDLE SHAFT AND PADDLE
 ARMS. SEE PADDLE SHAFT AND PADDLE
 ARM ASSEMBLIES IN THIS MANUAL.

DUMP HANDLE (ITEM 33) AND ASSOCIATED MOUNTING
 △ 2 HARDWARE (ITEMS 5, 10 AND 18) ONLY INCLUDED WITH
 MANUAL DUMP ASSEMBLY. DO NOT USE HANDLE ON
 HYDRAULIC DUMP MODELS.

PLASTIC MIXING DRUM ASSY.

<u>NO</u>	<u>PART NO</u>	<u>PART NAME</u>	<u>QTY.</u>	<u>REMARKS</u>
1#	3309	GRATE, MOVABLE	1	
2#	EM963057	HHCS 3/8 X 1-1/2"	6	
3#	13270	GRATE, STATIONARY	1	
4#	EM969013	NUT, NYLOC 3/8-16	8	
5#	6109170	WASHER, FLAT 1/2"	2	MANUAL DUMP ONLY
6#	504943	SCREW, FLATHEAD 3/8" NC X 2	8	
7#	3006	SUPPORT DISK	2	
8#	507719	BEARING HOUSING	2	
9#	511910	FHCS 1/4" NC X 1-1/4" G5	8	
10#	EM963692	HHCS 1/2-13" X 1-1/2" G5	2	MANUAL DUMP ONLY
11#	EM923025	WASHER, FLAT 3/8"	2	
12#	13209	REAR DRUM SUPPORT	1	
13#	491008	CAP, GREASE FITTING	4	
14#	EM916019	GREASE FITTING	4	
15#	492581	LOCK NUT, NYLON 1/4-20	8	
16#	EM621	WASHER, FLAT 1/2" SPECIAL	4	
17#	EM963105	SCREW, HHCS 1/2" NC X 2" G5	4	REPLACES EM492396
18#	10176	NUT, LOCK 1/2"-13	2	MANUAL DUMP ONLY
19	13228	PIN, DUMP CYLINDER	1	
20	3327	CYLINDER, DUMP	1	
21	511495	LOCK NUT 1" NC	1	
22	511526	SCREW HHCS 1" NC X 8	1	
23	509000	COTTER PIN 3/16" X 2"	1	
24	3047	SPACER, 2" X 1-1/8 X 1/4" L	2	
25	13286	SPACER, HYDRAULIC CYLINDER	1	
26#	EM963610	HHCS 3/8" NC X 1-1/4" G8	2	
27#	3485	DRUM SUPPORT	1	
28#	3382	LATCH, TUB STAY	1	
29#	2219	PIN, COTTER 1/8" X 1-1/2"	1	
30#	3249	CAP, DUST	1	
31#	13218	DUMP BEARING HOUS. BRACKET REAR	1	
32#	3500	DUMP BEARING HOUS. BRACKET FRONT	1	
33	EM201537	MANUAL DUMP HANDLE	1	MANUAL DUMP ONLY. DO NOT USE ON HYDRAULIC DUMP MACHINE.
34#	3042	MIXER DRUM, PLASTIC, BARE	1	
35#	925191	PIN, HITCH CLIP	1	
36#	0401450160	WASHER, FLAT 16 MM ZINC	1	REPLACES 492602
37#	511493	BAR, GRATE LATCH	1	
38#	EM963692	HHCS 1/2"-13 X 1-1/2"	1	
39#	492584	NUT, LOCK 1/2"	7	
40#	8151	WASHER, FLAT SAE 3/4"	1	
41	512181	DRUM AND SHAFT ASSY. MAN./HYD. DUMP ..	1	INCLUDES ITEMS W/#

STEEL DRUM ASSY. (MANUAL)

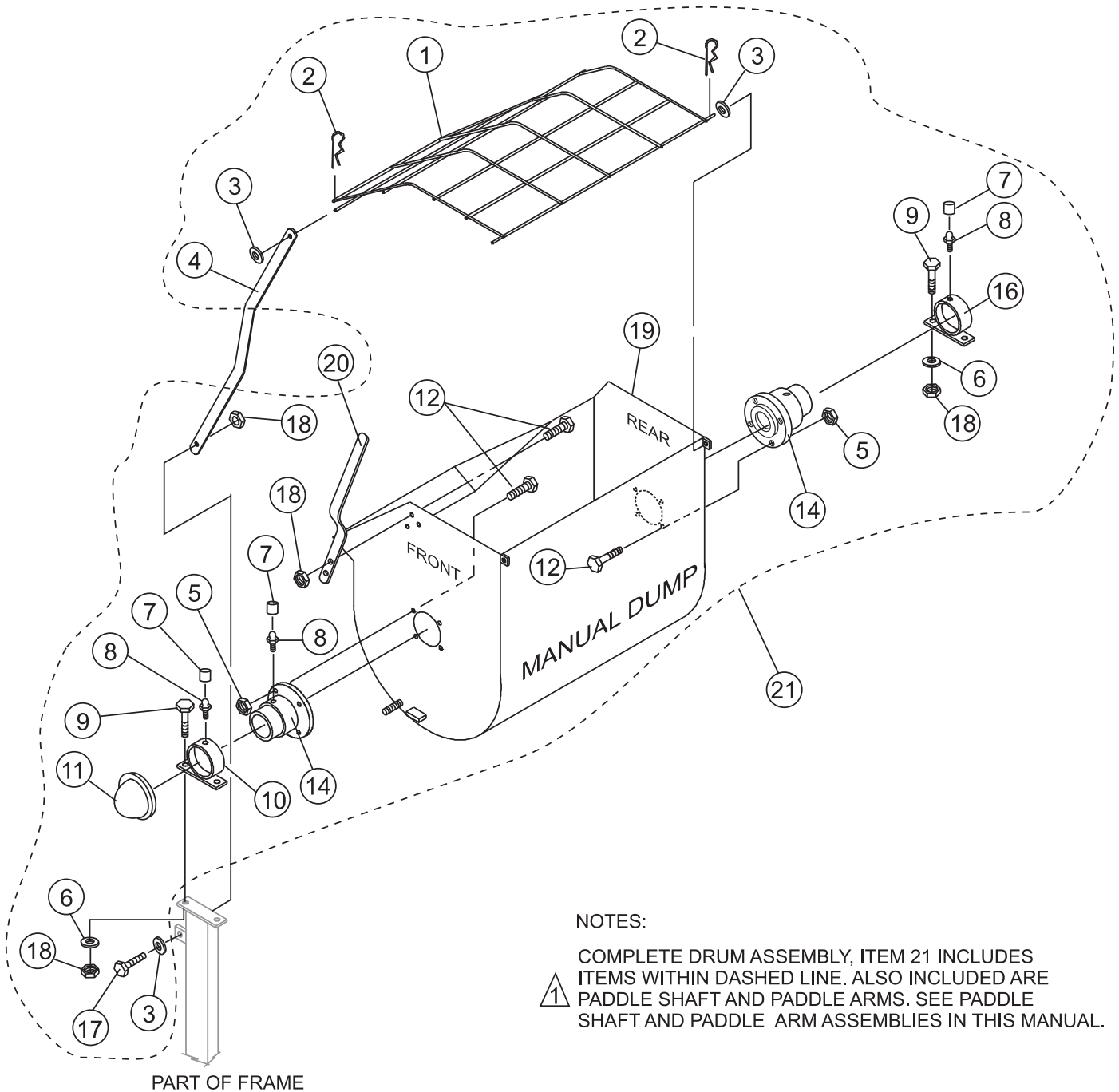

NOTES:

- COMPLETE DRUM ASSEMBLY, ITEM 21 INCLUDES ITEMS WITHIN DASHED LINE. ALSO INCLUDED ARE PADDLE SHAFT AND PADDLE ARMS. SEE PADDLE SHAFT AND PADDLE ARM ASSEMBLIES IN THIS MANUAL.

STEEL DRUM ASSY. (MANUAL)

<u>NO</u>	<u>PART NO</u>	<u>PART NAME</u>	<u>QTY.</u>	<u>REMARKS</u>
1#	EM203449	GRATE, MOVABLE	1	
2#	7170	5/32" 3-5/16"	2	
3#	6109170	WASHER, FLAT 1/2"	3	
4#	13276	BAR, GRATE LATCH	1	
5#	EM969013	NUT, NYLOC 3/8"	8	
6#	EM621	WASHER, FLAT 1/2" SPECIAL	4	
7#	491008	CAP, GREASE FITTING	4	
8#	EM916019	GREASE FITTING	4	
9#	EM963105	SCREW, HHCS 1/2" NC X 2" G5	4.....	REPLACES EM492396
10#	13260	FRONT DUMP SUPPORT BRACKET	1	
11#	3249	CAP, DUST	1	
12#	EM963610	HHCS 3/8" NC X 1-1/4" G8	8	
13#	EM924015	PIN, COTTER 3/16" X 1	2	
14#	3291	BEARING HOUSING FRONT	1	
15#	516457	BEARING HOUSING, REAR	1	
16#	13259	REAR DUMP SUPPORT BRACKET	1	
17#	EM963692	HHCS 1/2"-13 X 1-1/2"	1	
18#	492584	NUT, LOCK 1/2"	7	
19#	512245	STEEL DRUM, MANUAL	1	
20	EM201537	MANUAL DUMP HANDLE	1	
21	512180	DRUM AND SHAFT ASSY. MANUAL	1.....	INCLUDES ITEMS W/#

STEEL DRUM ASSY. (HYDRAULIC)

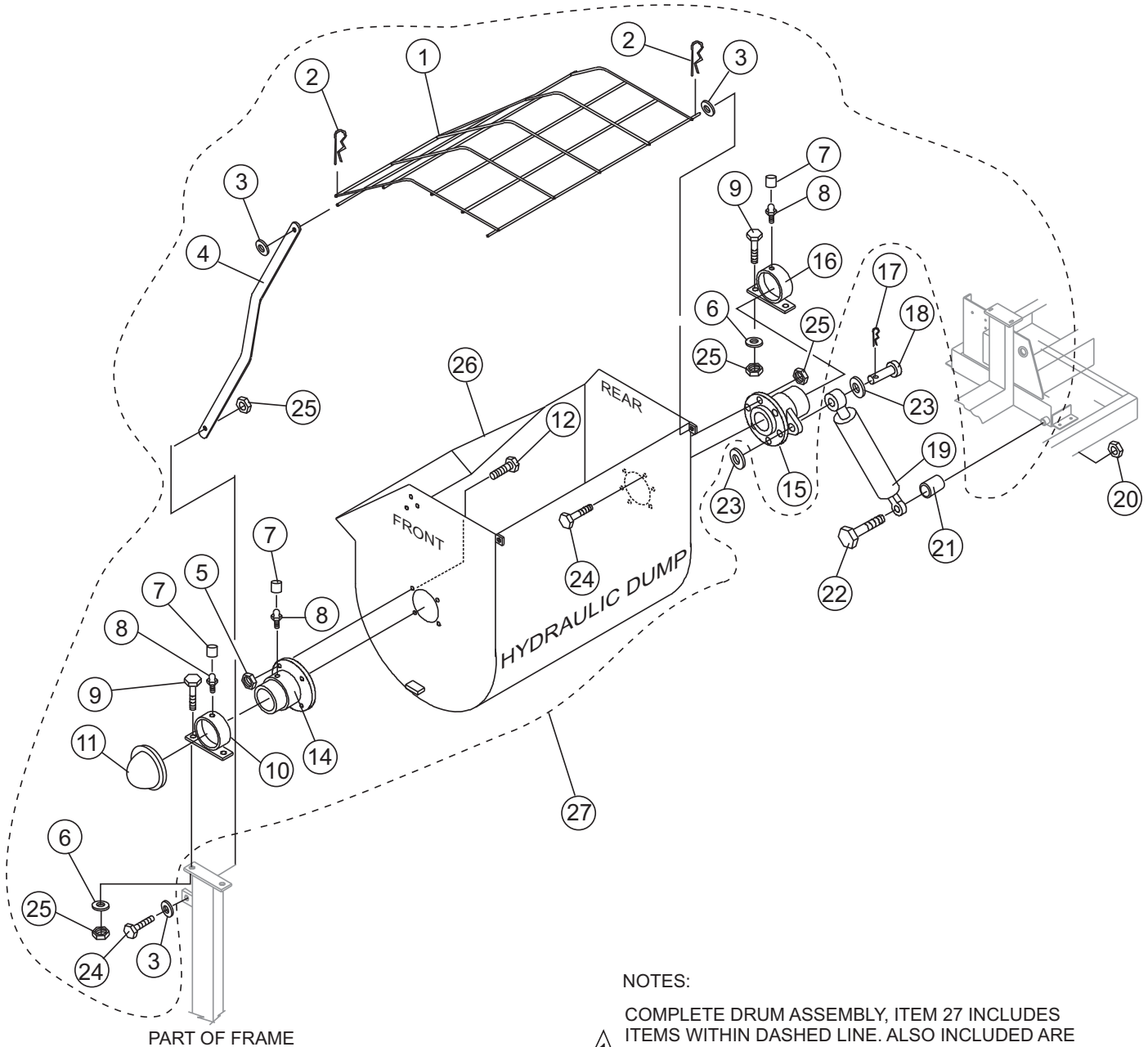

NOTES:

- COMPLETE DRUM ASSEMBLY, ITEM 27 INCLUDES ITEMS WITHIN DASHED LINE. ALSO INCLUDED ARE PADDLE SHAFT AND PADDLE ARMS. SEE PADDLE SHAFT AND PADDLE ARM ASSEMBLIES IN THIS MANUAL.

STEEL DRUM ASSY. (HYDRAULIC)

<u>NO</u>	<u>PART NO</u>	<u>PART NAME</u>	<u>QTY.</u>	<u>REMARKS</u>
1#	EM203449	MOVEABLE GRATE	1	
2#	7170	PIN, HITCH CLIP 5/32" 3-5/16"	2	
3#	6109170	WASHER, FLAT 1/2"	3	
4#	13276	BAR, GRATE	1	
5#	EM969013	NUT, NYLOC 3/8"	4	
6#	EM621	WASHER, FLAT 1/2" SPECIAL	4	
7#	491008	CAP, GREASE FITTING	4	
8#	EM916019	GREASE FITTING	4	
9#	EM963105	SCREW, HHCS 1/2" NC X 2" G5	4.....	REPLACES EM492396
10#	13260	FRONT DUMP SUPPORT BRACKET	1	
11#	3249	CAP, DUST	1	
12#	EM963610	HHCS 3/8" NC X 1-1/4" G8	4	
13#	EM924015	PIN, COTTER 3/16" X 1	2	
14#	3291	BEARING HOUSING FRONT	1	
15#	516457	BEARING HOUSING, REAR (6 HOLE)	1.....	EFFECTIVE S/N K-25 - NOV 2005
15#	511852	BEARING HOUSING, REAR (4 HOLE)	1	
16#	13259	REAR DUMP SUPPORT BRACKET	1	
17	509000	COTTER PIN 3/16" X 2"	1	
18	13228	PIN, DUMP CYLINDER	1	
19	3327	CYLINDER, DUMP	1	
20	511495	LOCK NUT 1" NC	1	
21	13286	SPACER, LOWER HYDRAULIC CYLINDER	1	
22	511526	SCREW HHCS 1" NC X 8	1	
23	3047	SPACER, 2" X 1-1/8 X 1/4" L	2	
24#	EM963692	HHCS 1/2"-13 X 1-1/2"	7	
25#	492584	NUT, LOCK 1/2"	11	
26#	516535	STEEL DRUM, HYDRAULIC	1	
27	511173	DRUM AND SHAFT ASSY. HYDRAULIC	1.....	INCLUDES ITEMS W/#

PADDLE SHAFT ASSY. (PLASTIC/STEEL)

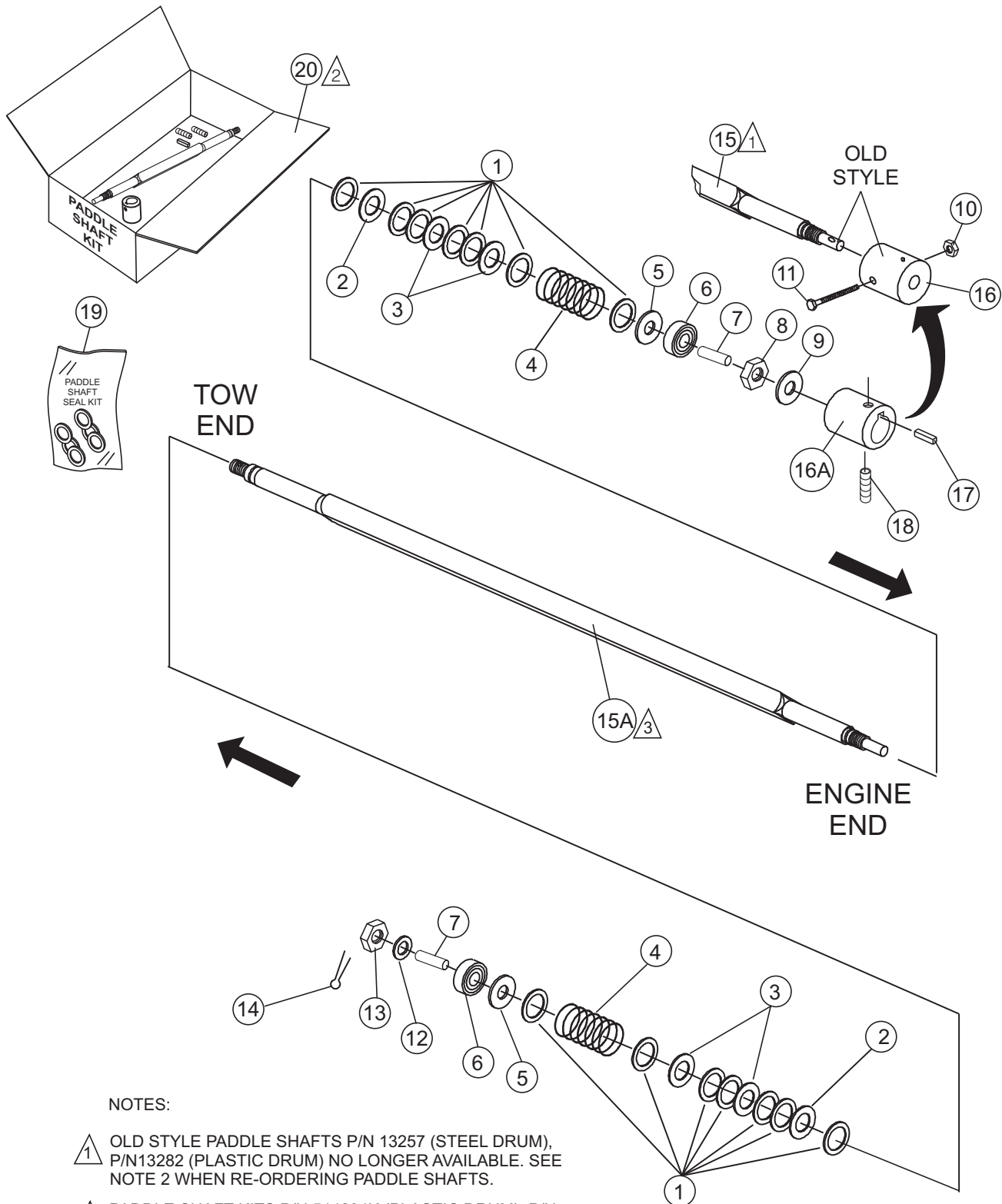

NOTES:

- 1 OLD STYLE PADDLE SHAFTS P/N 13257 (STEEL DRUM), P/N13282 (PLASTIC DRUM) NO LONGER AVAILABLE. SEE NOTE 2 WHEN RE-ORDERING PADDLE SHAFTS.
- 2 PADDLE SHAFT KITS P/N 514234K (PLASTIC DRUM), P/N 514233K (STEEL DRUM) INCLUDES ITEMS 15A, 16A, 17 AND 18.
- 3 FOR PLASTIC DRUM USE PADDLE SHAFT P/N 514234 , FOR STEEL DRUM USE PADDLE SHAFT P/N 514233.

PADDLE SHAFT ASSY. (PLASTIC/STEEL)

<u>NO</u>	<u>PART NO</u>	<u>PART NAME</u>	<u>QTY.</u>	<u>REMARKS</u>
1	3061	SPACER, THIN SEAL	14	
2#	3494	OUTER SEAL, URETHANE 1-1/4 OD	2	
3#	3019	INNER SEAL 1-1/8"	4	
4	3024	SPRING	2	
5	13002	SEAL, BEARING 1-1/2"	2	
6	EM902153	BEARING	2	
7	13274	SPACER	2	
8	3347	NUT, SPECIAL 1-1/2"-12	1	
9	13108	WASHER, FLAT USS 1-1/8"	1	
10	10176	NUT, NYLOC 1/2-13	1	OCTOBER 2002 AND BELOW
11	3215	HHCS 1/2-13 X 3.1/2"	1	OCTOBER 2002 AND BELOW
12	3047	SPACER, 2 X 1-1/8" X 1/4" L	1	
13	8164	NUT, SLOTTED HEX JAM 1-20	1	
14	EM924006	PIN, COTTER 1/8 X 3/4"	1	
15		PADDLE SHAFT (PLASTIC)	1	NOT AVAILABLE, ORDER ITEM 20
15		PADDLE SHAFT (STEEL)	1	NOT AVAILABLE, ORDER ITEM 20
15A%	514233	PADDLE SHAFT (STEEL)	1	
15A*	514234	PADDLE SHAFT (PLASTIC)	1	
16	13156	COUPLER, PIN STYLE	1	OCTOBER 2002 AND BELOW
16A%*	514235	COUPLER, KEY STYLE	1	NOVEMBER 2002 AND ABOVE
17%*	EM502727	KEY, SQUARE 5/16 X 1-3/8"	1	NOVEMBER 2002 AND ABOVE
18%*	0857	SCREW, SHS 5/16-24 X 1/2"	1	NOVEMBER 2002 AND ABOVE
19	3530	KIT, SEAL, PADDLE SHAFT	1	INCLUDES ITEMS W/#
20	514234K	KIT, PADDLE SHAFT (PLASTIC)	1	INCLUDES ITEMS W/%
20	514233K	KIT, PADDLE SHAFT (STEEL)	1	INCLUDES ITEMS W/*



EFFECTIVE NOVEMBER 2002- THE PADDLE SHAFT CONNECTOR PIN HAS BEEN DISCONTIUED.THE COUPLER IS NOW KEYED TO THE PADDLE SHAFT.

HYDRAULIC ASSY.

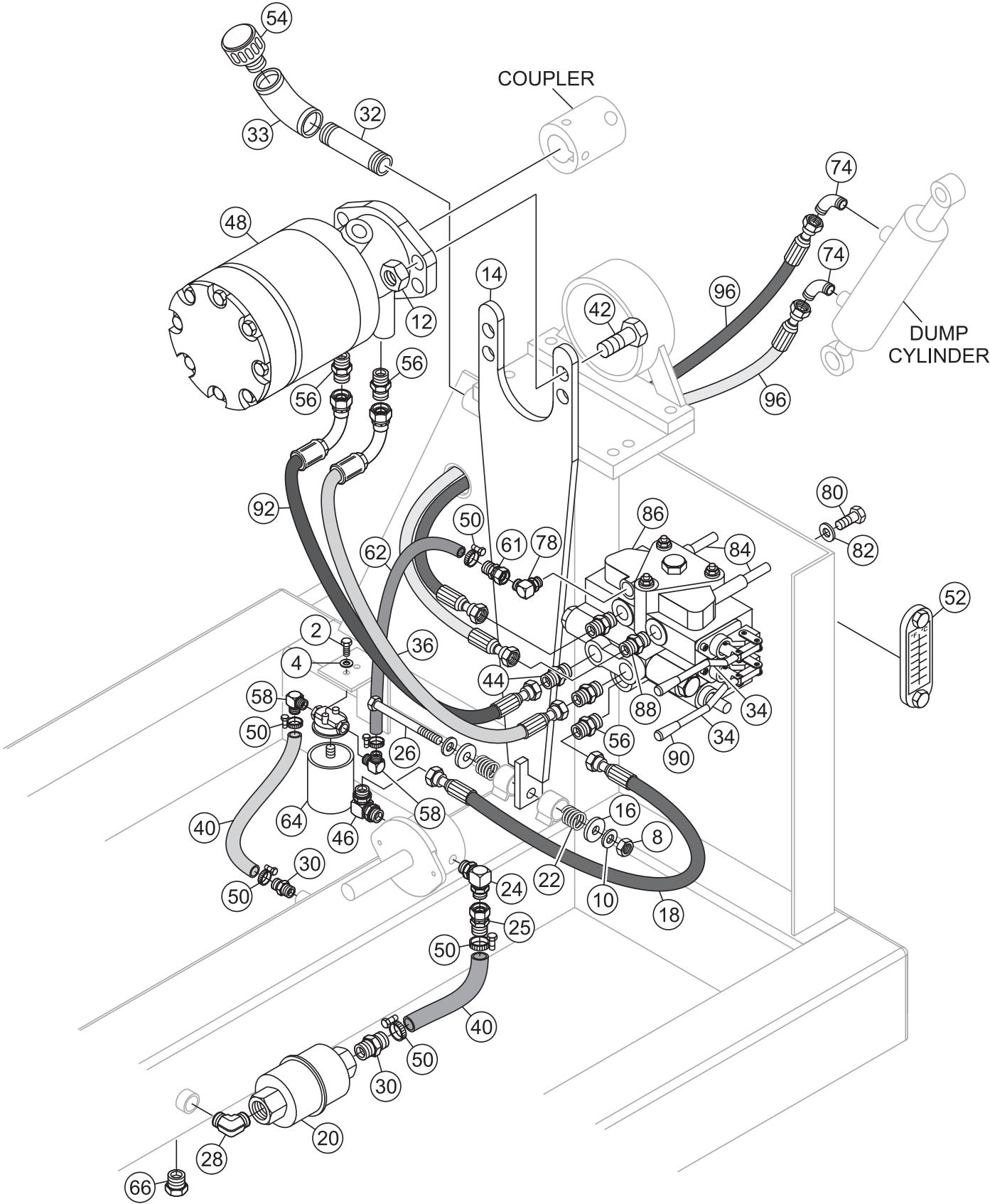

HYDRAULIC ASSY.

<u>NO.</u>	<u>PART NO.</u>	<u>PART NAME</u>	<u>QTY.</u>	<u>REMARKS</u>
2	492356	BOLT 1/4" X 3/4"	2	
4	2101402	WASHER, SPRING 1/4"	2	REPLACES 492622
8	EM969013	NUT, NYLOCK	1	REPLACES 492583
10	3019092	WASHER 3/8" FLAT	2	REPLACES 492598
12	492584	NUT, LOCK 1/2"	4	
14	13147	ARM, MOTOR TORQUE	1	
16	13153	CAP, SPRING MOUNT	2	
18	13196	HOSE, PUMP OUTPUT 21"	1	
20	13210	STRAINER, IN LINE	1	
22	13213	SPRING, DIE	2	
24	EM25459	ELBOW 3/4"-90	1	
25	511847	FITTING	1	
26	511509	BOLT, 3/8" NC X 6" G5	1	
28	13219	FITTING 90 3/4 MP X 3/4 MP	1	
30	13220	FITTING, STR 12BARB X 3/4MP	1	
32	511691	FITTING, STR	1	
33	510263	FITTING, 90DEG STRAIGHT ELBOW	1	
34	13225	HANDLE, DRIVE VALVE CONTROL	2	
36	13243	HOSE W/ 90 DEG FITTING	1	
40	13380	HOSE, 3/4 ID X 18-1/2	2	
42	EM963105	HEX BOLT 1/2"-13 X 2"	4	REPLACES 492396
44	16587	FITTING, STR 10MJ-8MO	2	
46	3322	FITTING, 90 10MJ-10MO	1	
48	34570	MOTOR, HYDRAULIC	1	
50	506207	CLAMP HOSE HS-16	6	
52	18052	SIGHT GAUGE AA4724	1	
54	3353	CAP, FILLER/BREATHER	1	
56	3365	FITTING, STR 10MJ-10MO	3	
58	3367	FITTING, 90 12BARB-3/4MP	2	
61	511847	FITTING	1	
62	3462	HOSE	1	
64	8051	FILTER, HYDRAULIC OIL	1	
66	506094	PLUG 1/2" NPT GALVANIZED	1	
74	3369	FITTING, 90 4MJ-3/8MP	2	HYDRAULIC DUMP ONLY
78	515219	FITTING, 90 DEG	1	
80	503117	BOLT 3/8" NC X 3" G5	3	
82	0166 A	WASHER, LOCK 3/8" MED	3	
84	515251	SPACER	3	
86	34585	VALVE, FOUR WAY ASSY.	1	HYDRAULIC DUMP ONLY
86	3385	VALVE, TWO WAY	1	MANUAL DUMP ONLY
88	511845	FITTING, STR.	2	HYDRAULIC DUMP ONLY
90	3407	KNOB	2	
92	13243	HOSE W/ 90 DEG FITTING	1	
96	TBD	HOSE	2	HYDRAULIC DUMP ONLY

FRAME 1 ASSY.

4 LUG HUB AND WHEEL (1-1/16 AXLE SPINDLE)
S/N KA26943 T0 HD27963
JANUARY 1996 — APRIL 1999

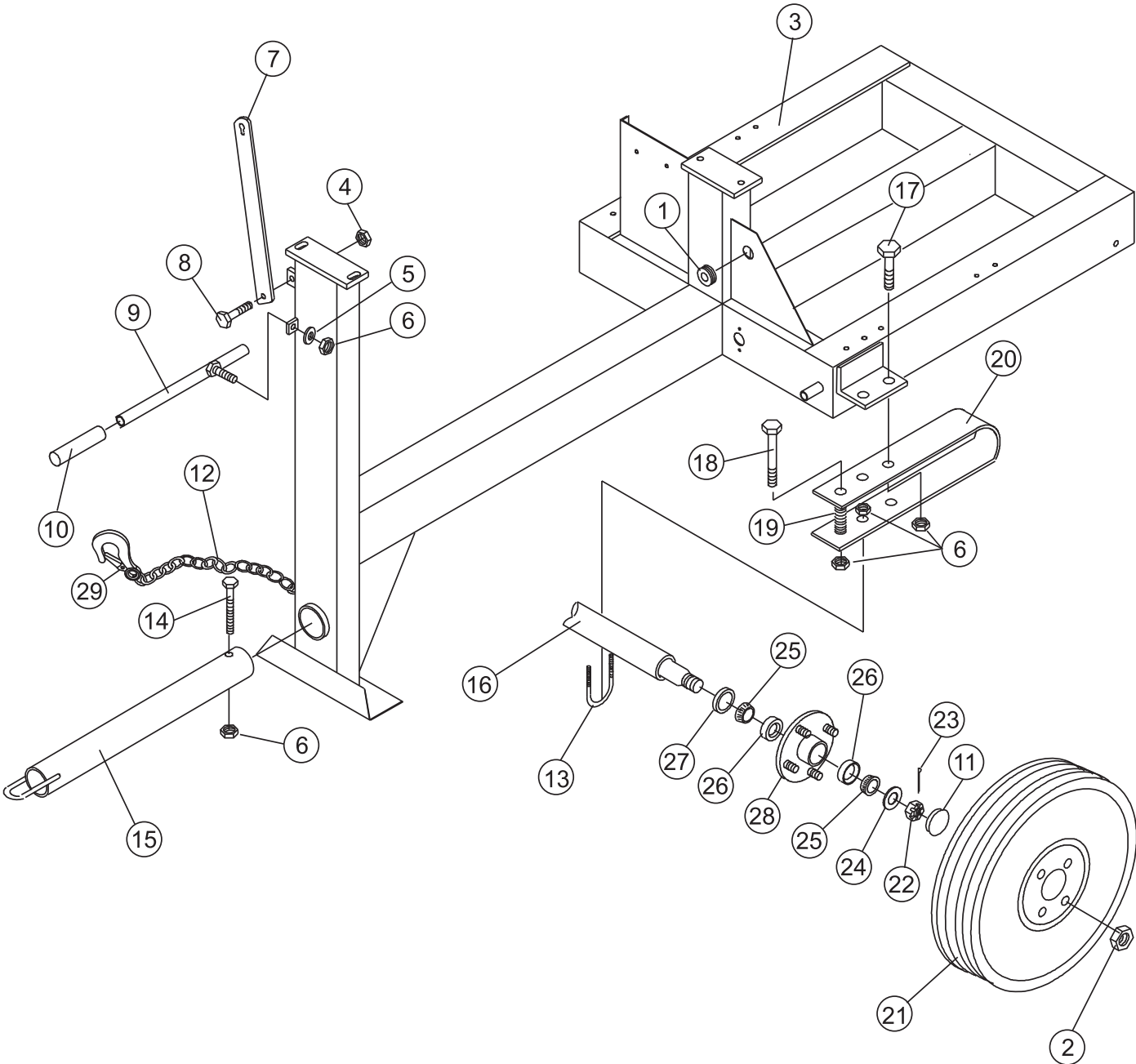

FRAME 1 ASSY.

4 LUG HUB AND WHEEL (1-1/16 AXLE SPINDLE)

S/N KA26943 TO HD27963

JANUARY 1996 — APRIL 1999

<u>NO</u>	<u>PART NO</u>	<u>PART NAME</u>	<u>QTY.</u>	<u>REMARK</u>
1	13212	GROMMET	1	WITH DUMP (HYDRAULIC DUMP CYL.)
2	29194	LUG NUT	8	REPLACES 8115
3	13120	MAIN FRAME	1	S/N KA26943 TO I127769
			NO LONGER AVAILABLE. USE 13365.
3	13365	MAIN FRAME	1	S/N I127770
4	10133	LOCK NUT 3/8-16	1	
5	0447	FLAT WASHER 1/2"	1	
6	10176	LOCK NUT 1/2-13	12	
7	511493	GRATE LATCH	1	
8	1023	HHCS 3/8-16 X 1.1/4"	1	
9	13280	DRUM LOCK LEVER	1	W/O DUMP (MANUAL ONLY)
10	3102	HANDLE GRIP	1	W/O DUMP (MANUAL ONLY)
11	3469	DUST CAP	2	REPLACEMENT ONLY
12	13363KIT	SAFETY CHAIN ASSY	1	REPLACES 3148
13	3028	U-BOLT	2	
14	3215	HHCS 1/2-13 X 3.1/2"	1	
15	HLC-1	TOW BAR (LOOP)	1	CONTACT UNIT SALES
15	HPC-1	TOW BAR (1 " PIN)	1	CONTACT UNIT SALES
15	HBC-1	TWO BAR (BALL HITCH 2 -INCH)	1	CONTACT UNIT SALES
16	3400	AXLE & HUB ASSY.	2	
17	5218	HHCS 1/2-13 X 1.1/2"	4	
18	3043	HHCS 1/2-13 X 6"	2	
19	3076	AXLE SPRING	2	
20	3018	LEAF SPRING	2	
21	3005	WHEEL & TIRE B78-13 (4 HOLE)	2	
22	12426	CASTLE NUT	2	REPLACES 3068
23	0183	COTTER PIN	2	
24	8151	FLAT WASHER 3/4"	2	
25	3496	BEARING CONE	4	
26	EM903012	BEARING CUP	4	REPLACES 3067
27	3065	SEAL	2	
28	3504	HUB W/BEARING CUPS (4-LUGS)	2	
29	516180	SAFETY HOOK	1	

FRAME 2 ASSY.

5 LUG HUB AND WHEEL (1-1/16 AXLE SPINDLE)
S/N HD27964 TO GE210000
APRIL 1999 — MAY 2000

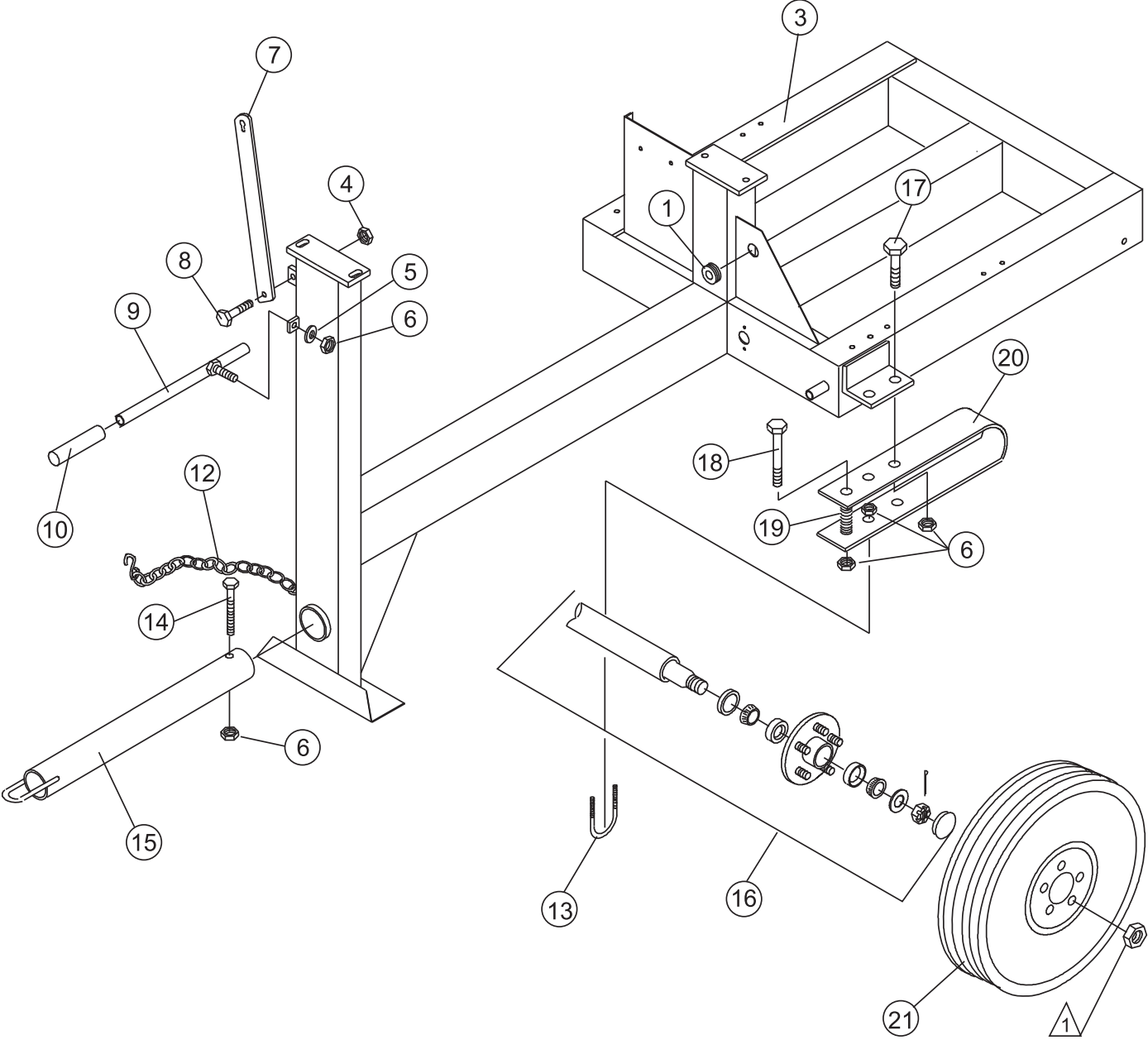

NOTES:
▲ WHEEL LUG NUTS ARE INCLUDED WITH ITEM 16.

FRAME 2 ASSY.

5 LUG HUB AND WHEEL (1-1/16 AXLE SPINDLE)

S/N HD27964 TO GE210000

APRIL 1999 — MAY 2000

<u>NO</u>	<u>PART NO</u>	<u>PART NAME</u>	<u>QTY.</u>	<u>REMARK</u>
1	13212	GROMMET	1	WITH DUMP (HYDRAULIC DUMP CYL.)
3	13120	MAIN FRAME	1	S/N KA26943 TO I127769
3	13365	MAIN FRAME	1	S/N I127770
4	10133	LOCK NUT 3/8-16	1	
5	0447	FLAT WASHER 1/2"	1	
6	10176	LOCK NUT 1/2-13	12	
7	511493	GRATE LATCH	1	
8	1023	HHCS 3/8-16 X 1.1/4"	1	
9	13280	DRUM LOCK LEVER	1	W/O DUMP (MANUAL ONLY)
10	3102	HANDLE GRIP	1	W/O DUMP (MANUAL ONLY)
12	3148	SAFETY CHAIN ASM	1	
13	3028	U-BOLT	2	
14	3215	HHCS 1/2-13 X 3.1/2"	1	
15	HLC-1	TOW BAR (LOOP)	1	CONTACT UNIT SALES DEPT.
15	HPC-1	TOW BAR (1 " PIN)	1	CONTACT UNIT SALES DEPT.
15	HBC-1	TWO BAR (BALL HITCH 2 -INCH)	1	CONTACT UNIT SALES DEPT.
16	13382	AXLE & HUB ASM	2	NO LONGER AVAILABLE. SEE FRAME 3 ASSY.
17	5218	HHCS 1/2-13 X 1.1/2"	4	
18	3043	HHCS 1/2-13 X 6"	2	
19	3076	AXLE SPRING	2	
20	3018	LEAF SPRING	2	
21	19045	WHEEL & TIRE	2	

FRAME 3 ASSY.

5 LUG HUB AND WHEEL (1-1/16 AXLE SPINDLE)
S/N GE21000 AND ABOVE
MAY 2000 AND ABOVE

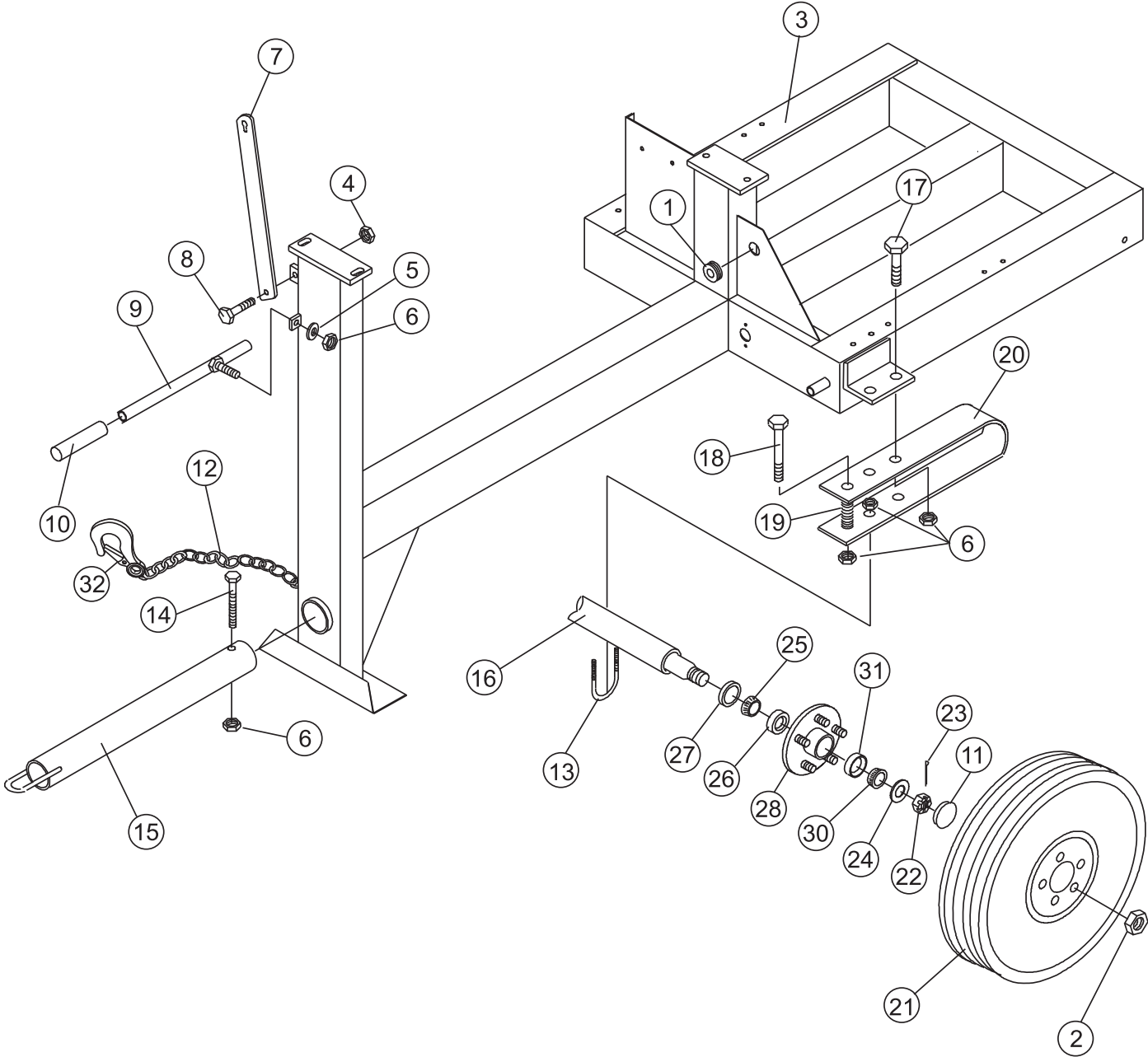

FRAME 3 ASSY.

5 LUG HUB AND WHEEL (1-1/16 AXLE SPINDLE)
S/N GE21000 AND ABOVE
MAY 2000 AND ABOVE

<u>NO</u>	<u>PART NO</u>	<u>PART NAME</u>	<u>QTY.</u>	<u>REMARK</u>
1	13212	GROMMET	1	WITH DUMP (HYDRAULIC DUMP CYL.)
2	EM941280	LUG NUT	8	
3	13120	MAIN FRAME	1	S/N KA26943 TO I127769 NO LONGER AVAILABLE. USE 13365.
3	13365	MAIN FRAME	1	S/N I127770
4	10133	LOCK NUT 3/8-16	1	
5	0447	FLAT WASHER 1/2"	1	
6	10176	LOCK NUT 1/2-13	12	
7	511493	GRATE LATCH	1	
8	1023	HHCS 3/8-16 X 1.1/4"	1	
9	13280	DRUM LOCK LEVER	1	W/O DUMP (MANUAL ONLY)
10	3102	HANDLE GRIP	1	W/O DUMP (MANUAL ONLY)
11	EM941278	DUST CAP	2	REPLACEMENT ONLY
12	13363KIT	SAFETY CHAIN ASM	1	REPLACES 3148
13	3028	U-BOLT	2	
14	3215	HHCS 1/2-13 X 3-1/2"	1	
15	HLC-1	TOW BAR (LOOP)	1	CONTACT UNIT SALES
15	HPC-1	TOW BAR (1 " PIN)	1	CONTACT UNIT SALES
15	HBC-1	TWO BAR (BALL HITCH 2 -INCH)	1	CONTACT UNIT SALES
16	511699	AXLE, NEW STYLE	1	
17	5218	HHCS 1/2-13 X 1-1/2"	4	
18	3043	HHCS 1/2-13 X 6"	2	
19	3076	AXLE SPRING	2	
20	3018	LEAF SPRING	2	
21	19045	WHEEL & TIRE	2	
22*	EM968302	CASTLE NUT, 3/4-16	2	
23	0183	COTTER PIN, 1/8X1-1/4	2	
24*	EM923161	FLAT WASHER 3/4"	2	
25*	EM903168	BEARING CONE INNER	4	
26*	EM903169	BEARING CUP INNER	4	
27*	EM914324	SEAL	2	
28	EM941277	HUB W/BEARING CUPS (5-LUG)	2	INCLUDES ITEMS W/*
30*	EM903113	BEARING CONE OUTER	2	
31*	EM903012	BEARING CUPS OUTER	2	
32	516180	SAFETY HOOK	1	

PLASTIC ENGINE COVER ASSY.

S/N KA26943 TO GE 210000
JANUARY 1996 TO MAY 2000

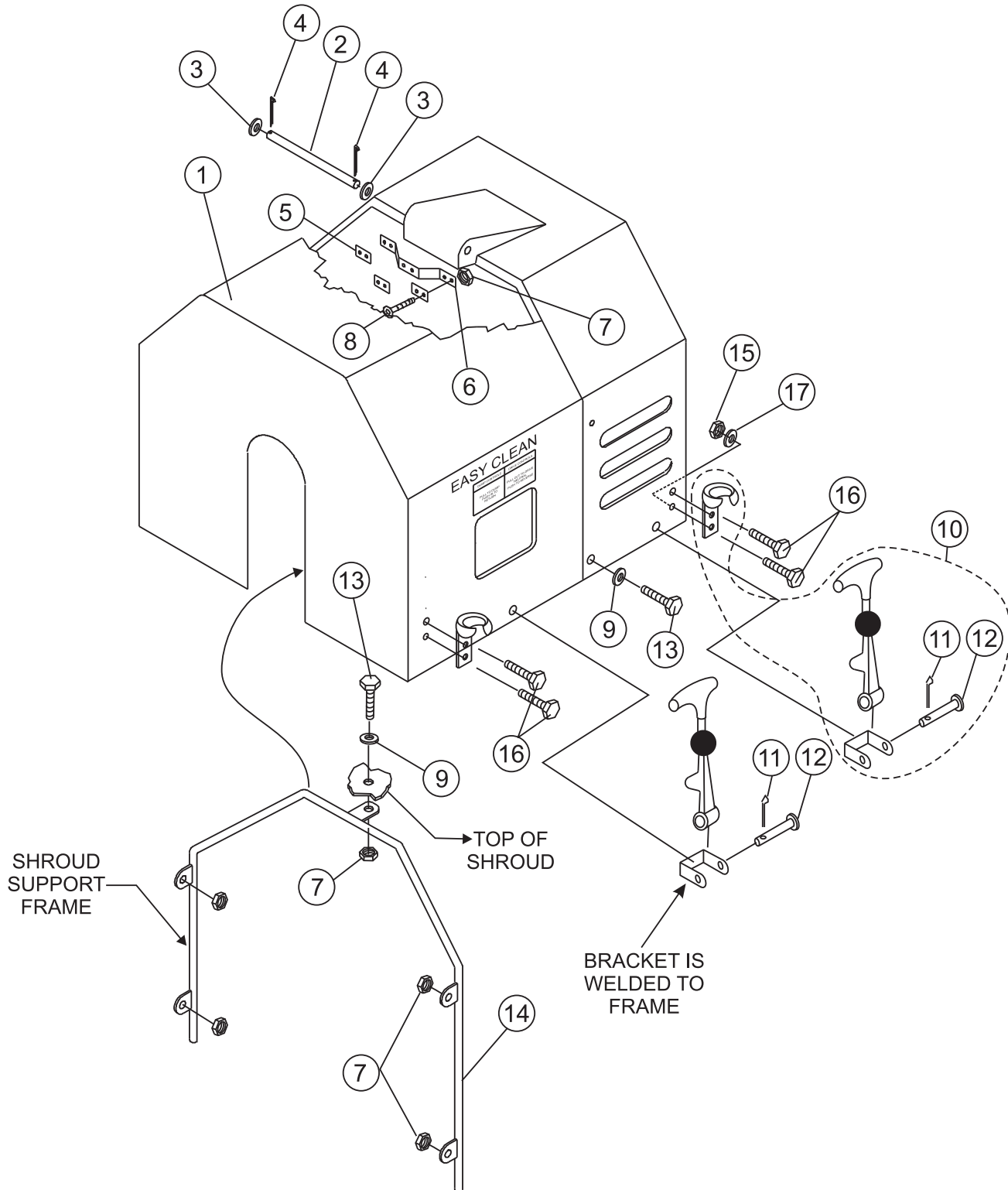

PLASTIC ENGINE COVER ASSY.

S/N KA26943 TO GE 210000

JANUARY 1996 TO MAY 2000

<u>NO</u>	<u>PART NO</u>	<u>PART NAME</u>	<u>QTY.</u>	<u>REMARK</u>
1	13221	ENGINE COVER ASSY. - PLASTIC ONLY	1	S/N KA26943 TO GE210000
2	3089	HINGE PIN	1	
3	8151	FLAT WASHER 3/4"	2	
4	0183	COTTER PIN	2	
5	3163	SMALL HINGE PLATE	3	
6	3162	LARGE HINGE PLATE	1	
7	10024	LOCK NUT 1/4-20	11	
8	3164	FHSCS 1/4-20 X 1"	6	
9	0948	LOCK WASHER 1/4"	10	
10	491010	SHROUD FASTENER ASSY.	4	REPLACES 929025
			INCLUDES ITEMS W/*
11*		COTTER PIN	4	
12*		CLEVIS PIN	4	
13	0131A	HHCS 1/4-20 X 3/4"	10	
14	3401	SHROUD BRACE	1	
15	13287	LOCK NUT 8-32	8	
16	1307	RHMS 8-32 X 1/2"	8	
17	2203	FLAT WASHER #10	4	

STEEL ENGINE COVER ASSY.

GE 210001 AND ABOVE
MAY 2000 AND ABOVE

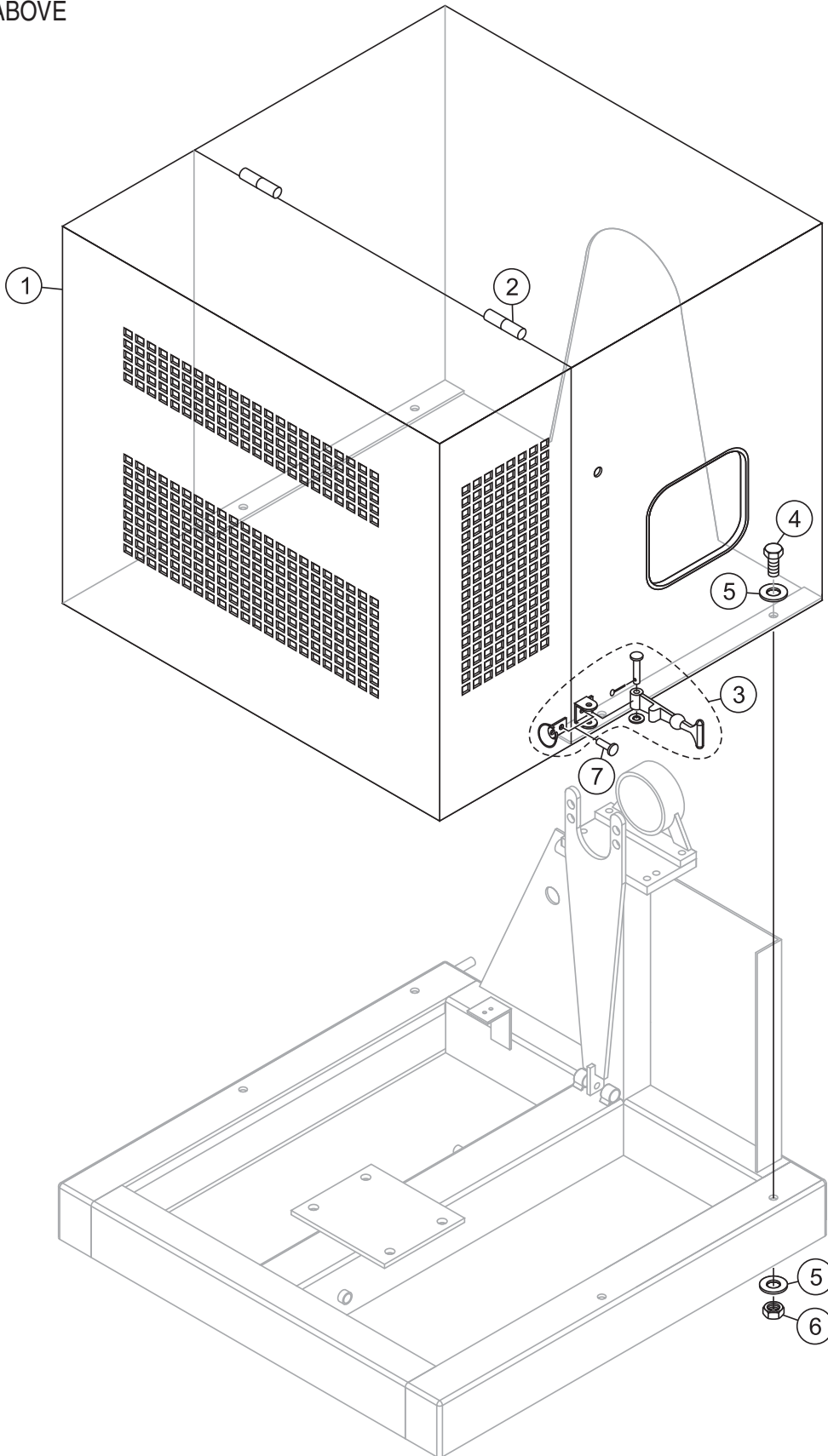

STEEL ENGINE COVER ASSY.

GE 210001 AND ABOVE
MAY 2000 AND ABOVE

<u>NO.</u>	<u>PART NO.</u>	<u>PART NAME</u>	<u>QTY.</u>	<u>REMARKS</u>
1	511580	ENGINE COVER-STEEL	1	S/N GE210001 AND ABOVE
2	509726	HINGE	2	
3	491010	RUBBER LATCH ASSY.	2	
4	1284	SCREW, HHCS 3/8-16 X 1-1/2"	4	
5	4001	FLAT WASHER 3/8"	8	
6	10133	LOCK NUT 3/8-16	4	
7	1307	RHMS 8-32 X 1/2"	6	

SINGLE PHASE, 5 HP ELECTRIC MOTOR ASSY.

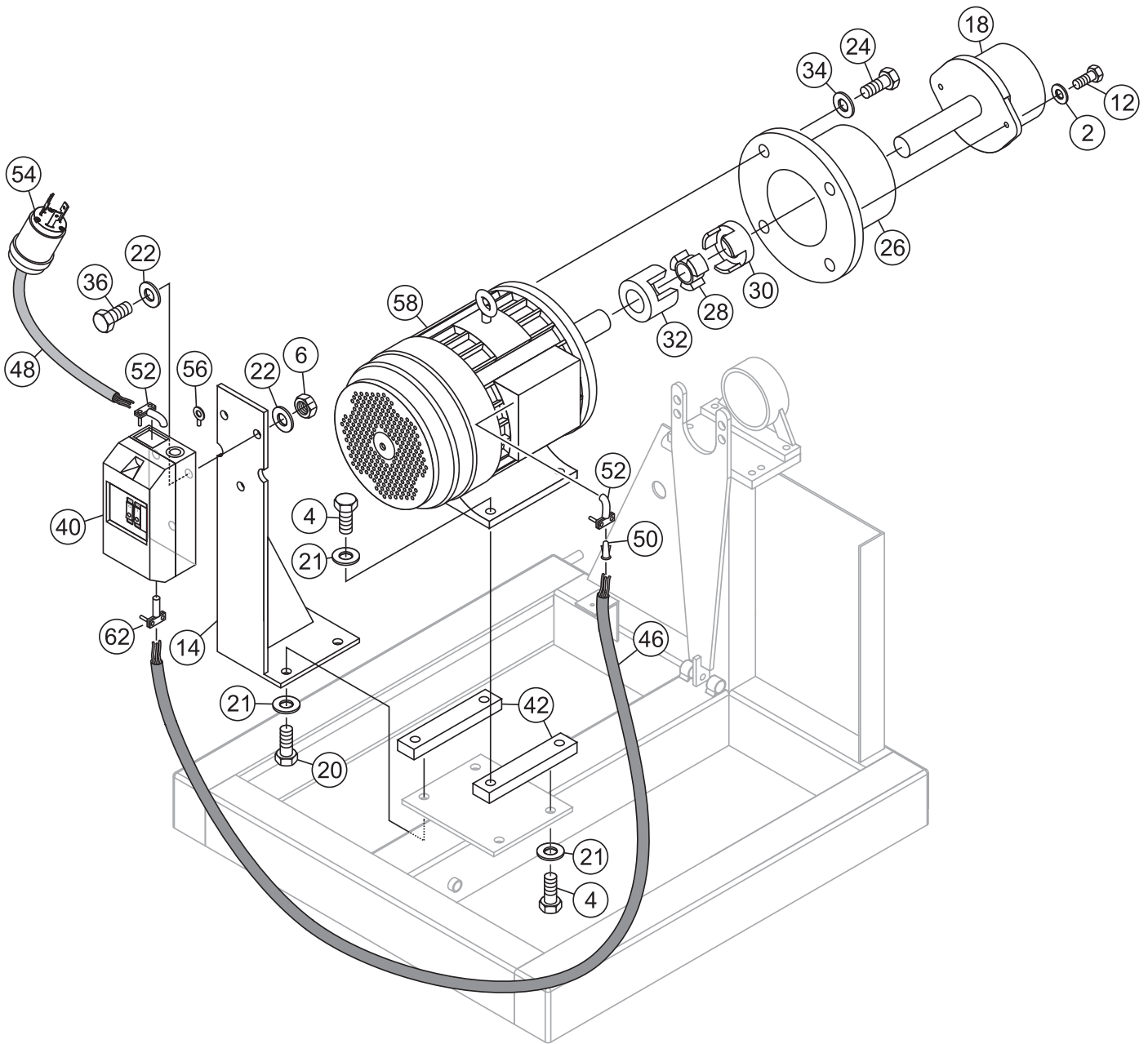

SINGLE PHASE, 5 HP ELECTRIC MOTOR ASSY.

<u>NO.</u>	<u>PART NO.</u>	<u>PART NAME</u>	<u>QTY.</u>	<u>REMARKS</u>
2	0166 A	WASHER, LOCK 3/8 MED.	2.....	REPLACES 492624
4	EM963610	CAPSCREW 3/8" NCX1-1/4" G8	6.....	REPLACES 492375
6	492581	NUT 1/4" - 20 NYLON LOCKNUT	3	
12	EM963610	CAPSCREW 3/8" NCX1-1/4" G8	2.....	REPLACES 492376
14	13291	STARTER MOUNT	1	
18	13375	PUMP, EATON 26005-RBBJ	1	
20	EM963610	CAPSCREW 3/8" NCX1-1/4" G8	2.....	REPLACES 492376
22	EM923057	WASHER 1/4"	6.....	REPLACES 492596
24	981635	BOLT, HEX 1/2" - 13 NCX1	4.....	REPLACES 492392
26	3416	ADAPTER, C-FACE PUMP	1	
28	3418	INSERT, RUBBER	1	
30	3420	COUPLER, PUMP END	1	
32	3421	COUPLER, MOTOR END	1	
34	6109180	WASHER, LOCK 1/2"	4.....	REPLACES 492626
36	492356	BOLT 1/4" X 3/4"	3	
40	EM98187	SWITCH ASSY, 5HP 1PH	1	
42	13289	BAR, MOTOR MOUNT	2	
46	511630	CABLE, .7 M	1	
48	508683	CABLE, .4 M	1	
50	505502	WIRE CONNECTOR	3	
52	EM940162	CONDUIT CONNECTOR	2	
54	EM201794	PIGTAIL ASSY 250 V 30A	1	
56	505403	TERMINAL	1	
58	3414	MOTOR, ELECTRIC, 5HP 1PH	1	
62	517031	CONNECTOR	1	

THREE PHASE, 5 HP ELECTRIC MOTOR ASSY.

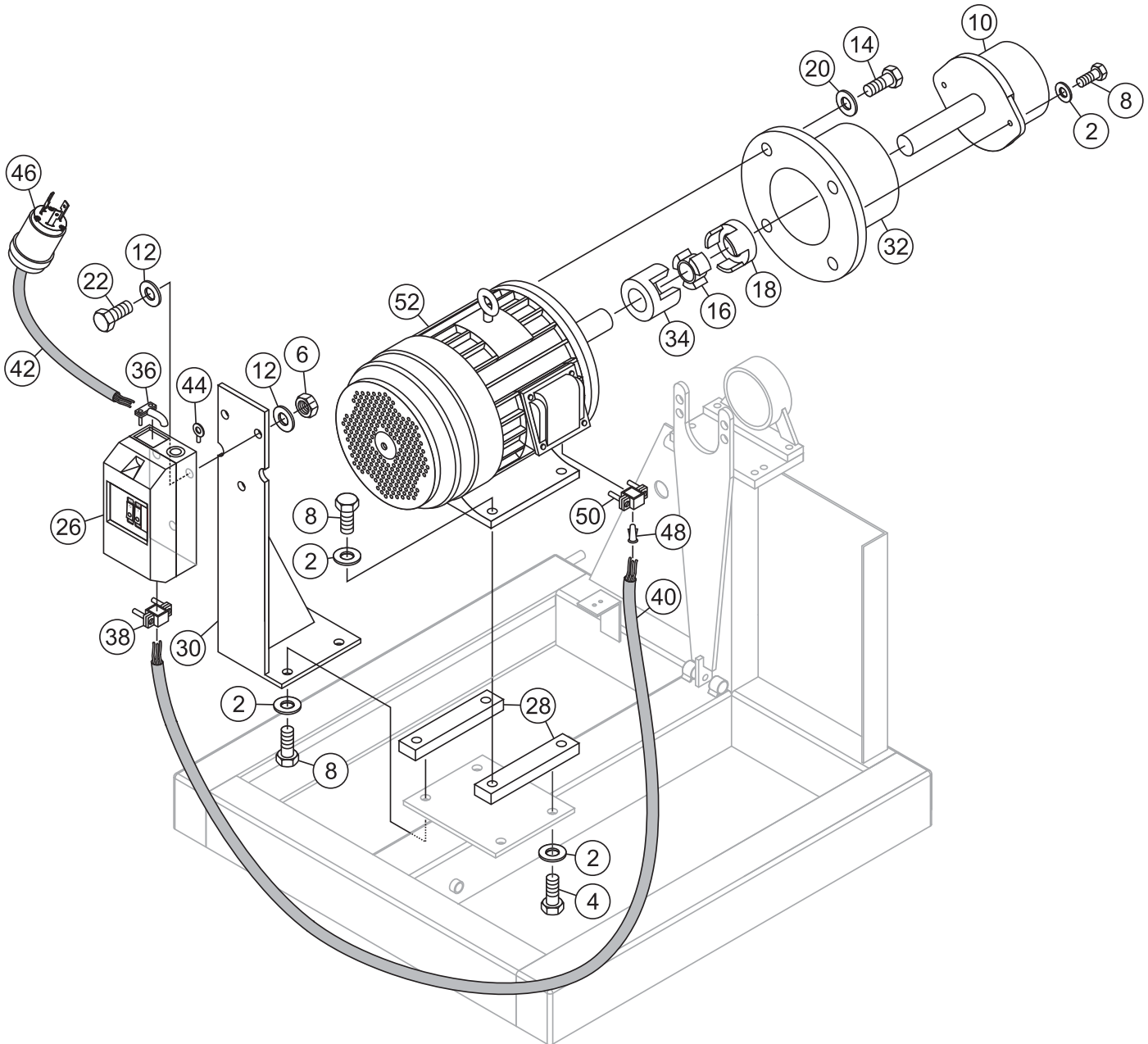

THREE PHASE, 5 HP ELECTRIC MOTOR ASSY.

<u>NO.</u>	<u>PART NO.</u>	<u>PART NAME</u>	<u>QTY.</u>	<u>REMARKS</u>
2	0166 A	WASHER, LOCK 3/8 MED.	10.....	REPLACES 492624
4	EM963610	CAPSCREW 3/8" NCX1-1/4" G8	2.....	REPLACES 492375
6	492581	NUT 1/4" - 20 NYLON LOCKNUT	3	
8	EM963610	CAPSCREW 3/8" NCX1-1/4" G8	8.....	REPLACES 492376
10	13375	PUMP, EATON 26005-RBBJ	1	
12	EM923057	WASHER 1/4"	6.....	REPLACES 492596
14	981635	BOLT, HEX 1/2" - 13 NCX1	4.....	REPLACES 492392
16	3418	INSERT, RUBBER	1	
18	3420	COUPLER, PUMP END	1	
20	6109180	WASHER, LOCK 1/2"	4.....	REPLACES 492626
22	492356	BOLT 1/4" X 3/4"	3	
26	EM98191	SWITCH ASSY, 5HP 3PH	1	
28	13289	BAR, MOTOR MOUNT	2	
30	13291	STARTER MOUNT	1	
32	3416	ADAPTER, C-FACE PUMP	1	
34	3421	COUPLER, MOTOR END	1	
36	EM940162	CONDUIT CONNECTOR	1	
38	517031	CONNECTOR	1	
40	508683	CABLE, .7 M	1	
42	511650	CABLE, .4 M	1	
44	505403	TERMINAL	1	
46	511647	3-PRONG PLUG	1	
48	EM940255	WIRE CONNECTOR	4	
50	512459	CONNECTOR	1	
52	3481	MOTOR, ELECTRIC, 5HP 3PH	1	

HONDA ENGINE ASSY.

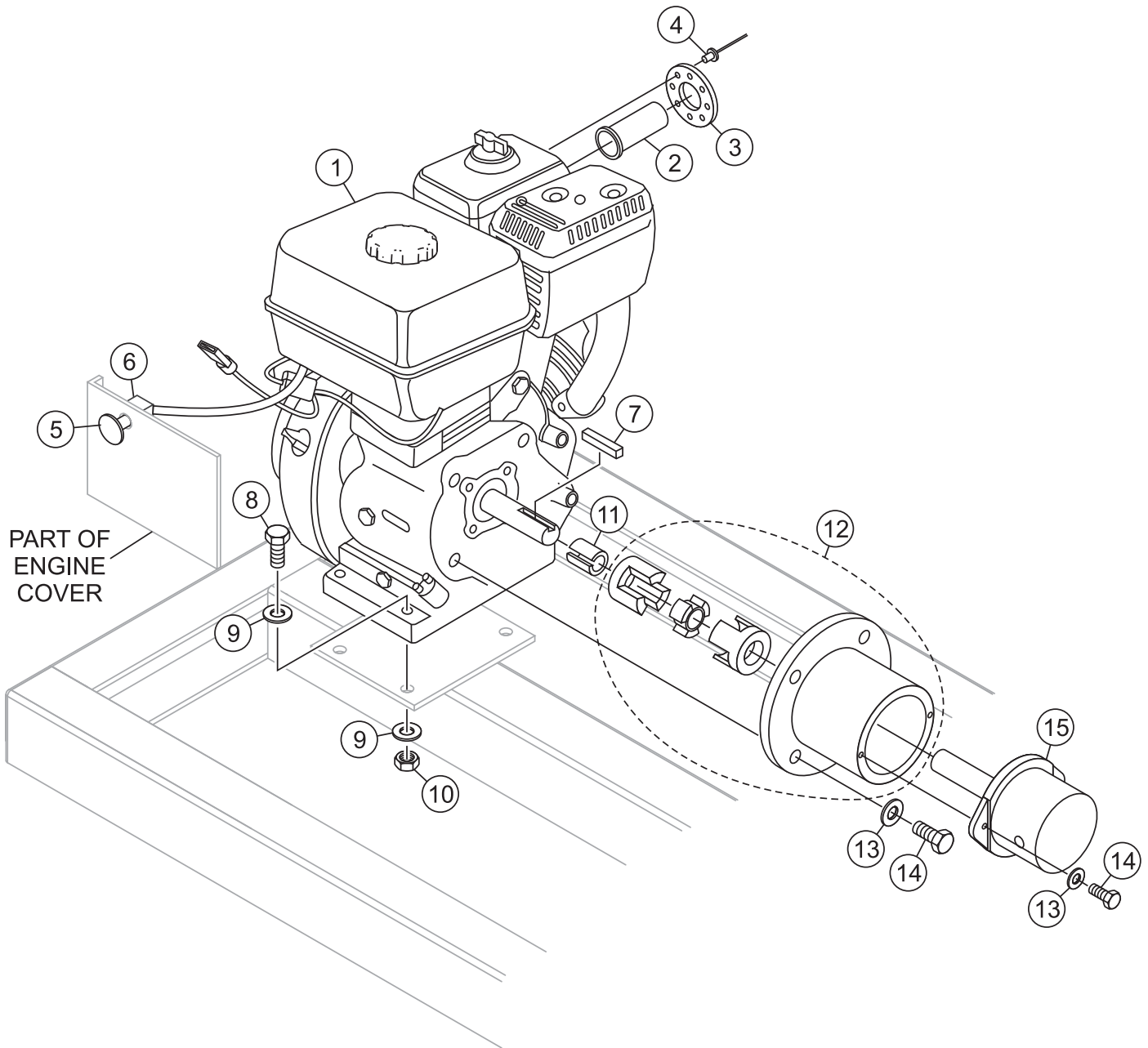

HONDA ENGINE ASSY.

<u>NO.</u>	<u>PART NO.</u>	<u>PART NAME</u>	<u>QTY.</u>	<u>REMARKS</u>
1	3364	ENGINE, HONDA 13HP GX390U1QA2	1	
2	203148	TUBE, EXHAUST	1	
3	203123F	PLATE	1	
4	491797	RIVET, ID PLATE	4	
5	29174-001	KNOB-MUSHROOM	1	
6	29173-001	SWITCH, PUSH-PULL W/O KNOB	1	
7	0310	KEY 1/4 SQUARE 1-1/2	1	
8	492379	SCREW CAP 3/8"	4	
9	3019092	WASHER 3/8" FLAT	6.....	REPLACES 492598
10	EM969013	NUT NYLOCK	4.....	REPLACES 492583
11	203040	SLEEVE, ENGINE SHAFT, HONDA	1	
12	516282	COUPLING ASSY	1	
13	0166 A	WASHER LOCK 3/8"	6.....	REPLACES 492624
14	EM963610	CAPSCREW 3/8" NC X 1-1/4" G8	6.....	REPLACES 492376
15	13374	PUMP, EATON 26003-RAG	1	

HONDA GX390K1QA2/GX390U1QA2 — AIR CLEANER ASSY.

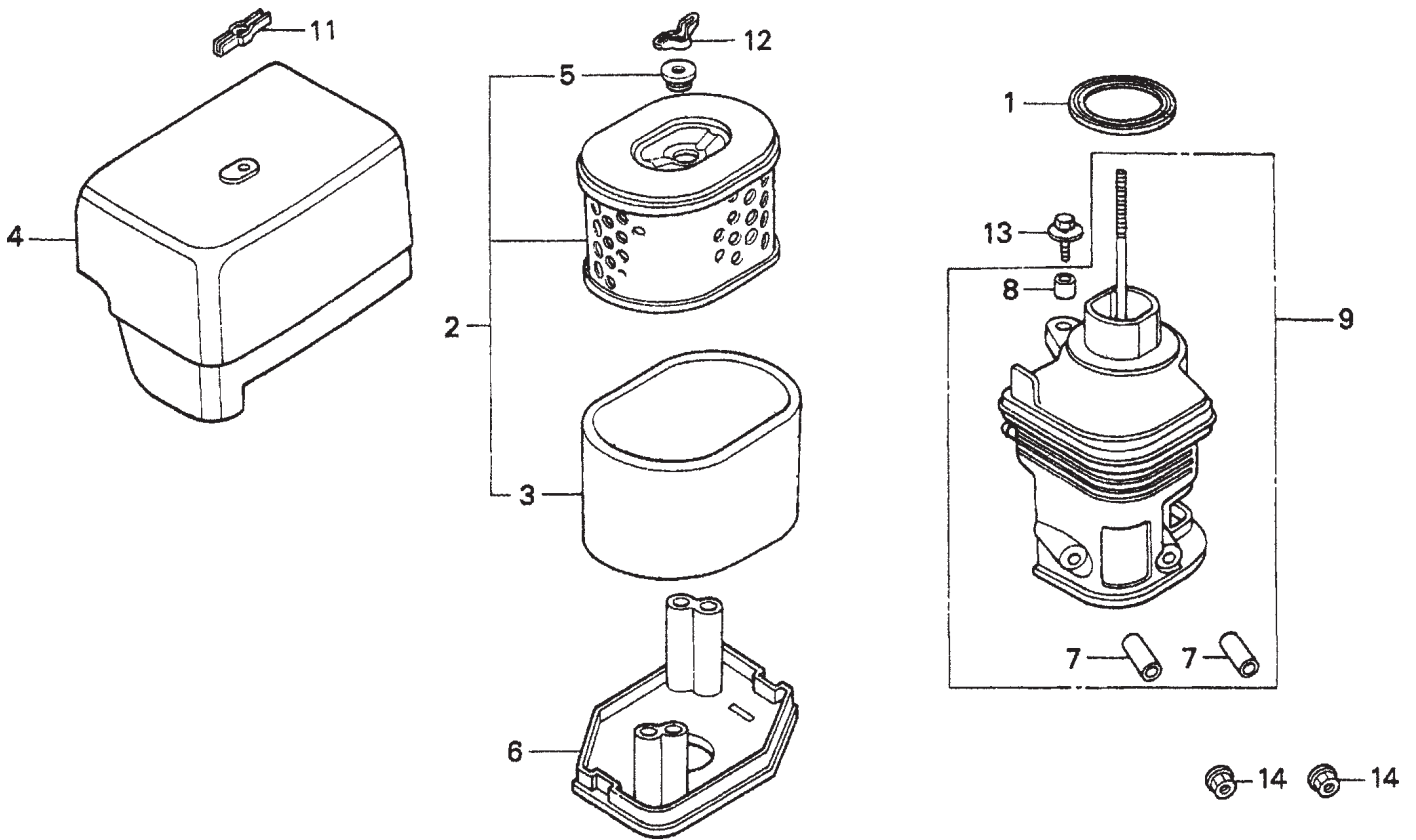

HONDA GX390K1QA2/GX390U1QA2 — AIR CLEANER ASSY.

<u>NO.</u>	<u>PART NO.</u>	<u>PART NAME</u>	<u>QTY.</u>	<u>REMARKS</u>
1	16271ZE2000	GASKET, ELBOW	1	
2	17210ZE3010	ELEMENT, AIR CLEANER	1	INCLUDES ITEMS W/#
3#	17218ZE3000	FILTER, OUTER	1	
4	17231ZE3W01	COVER, AIR CLEANER	1	
5#	17232891000	GROMMET, AIR CLEANER	1	
6✘	17235ZH9N00	NOSE, SILENCER	1	
6◇	17235ZH9N00	NOSE, SILENCER	1	S/N 1040439 AND BELOW
6◇	17235ZH9N01	NOSE, SILENCER	1	S/N 1040440 AND ABOVE
7*	17238ZE2310	COLLAR, AIR CLEANER	2	
8*	17239ZE1000	COLLAR B, AIR CLEANER	1	
9	17410ZH9N00	ELBOW, AIR CLEANER	1	INCLUDES ITEMS W/*
11	90203ZA0800	WINGNUT, 6MM	1	
12	90325044000	WINGNUT, TOOL BOX SETTING	1	
13	90009ZE2003	BOLT- WASHER 6X22	1	
14	9405006000	NUT, FLANGE 6MM	2	

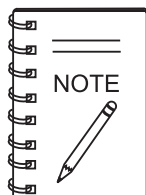

- ✘ GX390K1QA2: Model WM120 December 2006 And Below
- ◇ GX340U1QA2: Model WM120 January 2007 And Above

HONDA GX390K1QA2/GX390U1QA2 — CAMSHAFT ASSY.

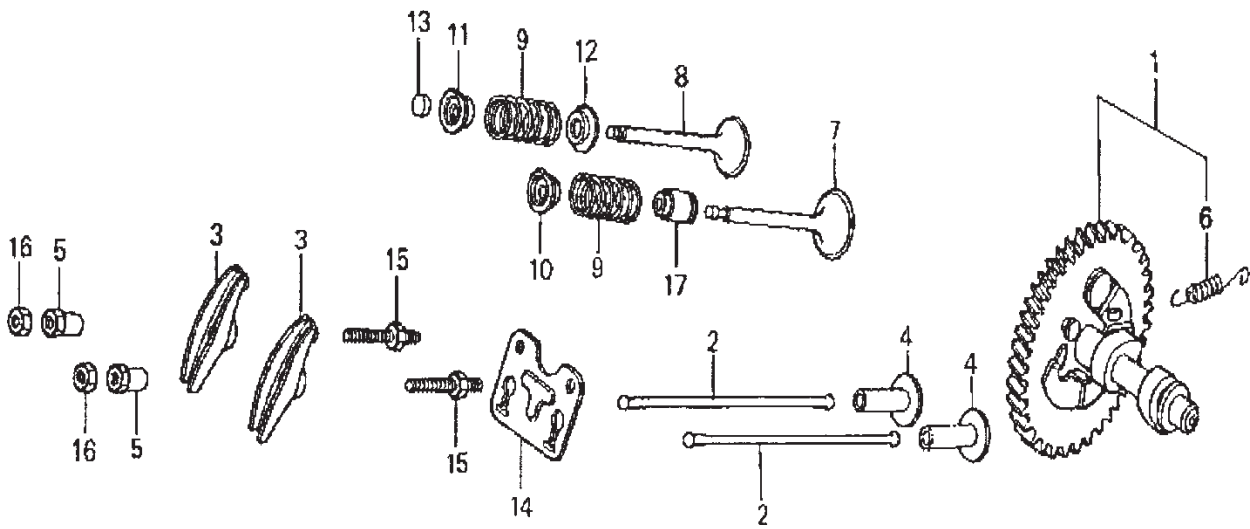

HONDA GX390K1QA2/GX390U1QA2 — CAMSHAFT ASSY.

NO.	PART NO.	PART NAME	QTY.	REMARKS
1✘	14100ZF6W0	CAMSHAFT ASSEMBLY	1	INCLUDES ITEMS W/* SN 2391939 AND BELOW
1✘	14100ZF6W01	CAMSHAFT ASSEMBLY	1	INCLUDES ITEMS W/* SN 2391940 AND ABOVE
1◇	14100ZF6W01	CAMSHAFT ASSEMBLY	1	
2	14410ZE3013	ROD, PUSH	2	
3	14431ZE2010	ARM, VALVE ROCKER.....	2.....	REPLACES 14431ZE2000
4	14441ZE2000	LIFTER, VALVE	2	
5	14451ZE1013	PIVOT, ROCKER ARM	2	
6*	14568ZE1000	SPRING, WEIGHT RETURN	1	
7	14711ZE3000	VALVE, INTAKE	1	
8	14721ZE3000	VALVE, EXHAUST	1	
9	14751ZE2003	SPRING, VALVE	2	
10	14771ZE2000	RETAINER, INTAKE VALVE SPRING	1	
11	14773ZE2000	RETAINER, EXHAUST VALVE SPRING	1	
12	14775ZE2010	SEAT, VALVE SPRING	1	
13	14781ZE2000	ROTATOR, VALVE	1	
14	14791ZE2010	PLATE, PUSH ROD GUIDE	1	
15	90012ZE0010	BOLT, PIVOT 8MM	2	
16	90206ZE1000	NUT, PIVOT ADJ.	2	
17✘	12209ZE8003	SEAL, VALVE STEM	1	USE FROM ENGINE SN 3065844
17◇	12209ZE8003	SEAL, VALVE STEM	1	



- ✘ GX390K1QA2: Model WM120 December 2006 And Below
- ◇ GX340U1QA2: Model WM120 January 2007 And Above

HONDA GX390K1QA2/GX390U1QA2 — PISTON ASSY.

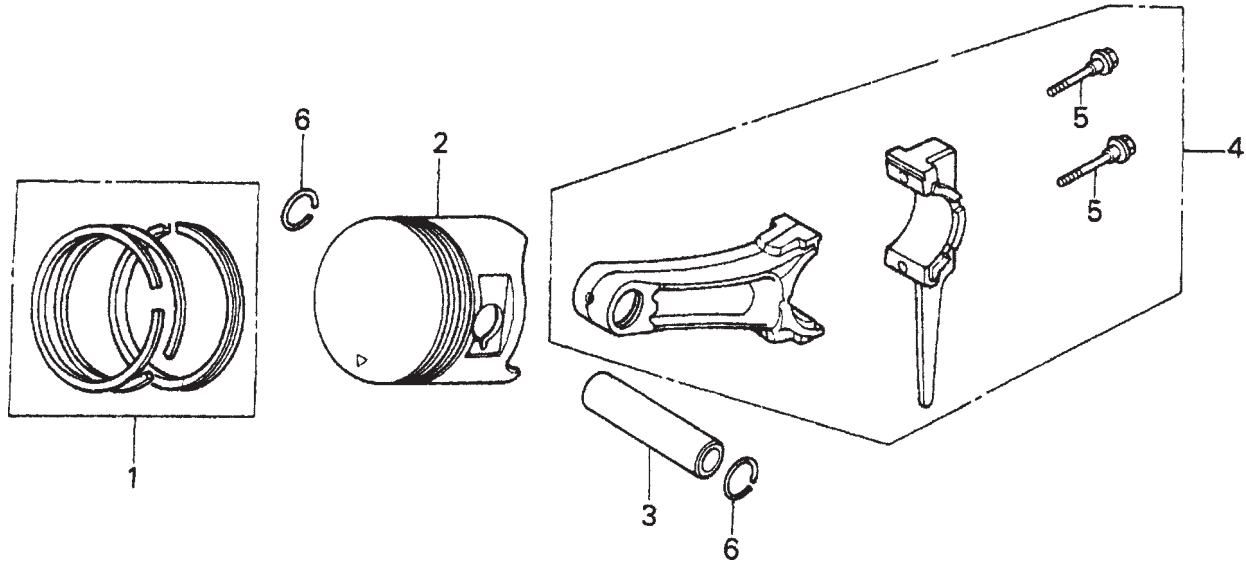

HONDA GX390K1QA2/GX390U1QA2 — PISTON ASSY.

NO.	PART NO.	PART NAME	QTY.	REMARKS
1	13010ZF6003	RING SET, PISTON (STD.)	1	
1	13010ZF6005	RING SET, PISTON (STD.)	1	
1	13011ZF6003	RING SET, PISTON (OS 0.25), OPT.	1	
1	13011ZF6005	RING SET, PISTON (OS 0.25), OPT.	1	
1	13012ZF6003	RING SET, PISTON (OS 0.50), OPT.	1	
1	13012ZF6005	RING SET, PISTON (OS 0.50), OPT.	1	
1	13012ZF6005	RING SET, PISTON (OS 0.50), OPT.	1	
1	13013ZF6003	RING SET, PISTON (0.75) NIP.,OPT.	1	
1	13013ZF6005	RING SET, PISTON (0.75) NIP.,OPT.	1	
2	13101ZF6W00	PISTON (STANDARD)	1	
2	13102ZF6W00	PISTON (OS 0.25), OPTIONAL	1	
2	13103ZF6W00	PISTON (OS 0.50), OPTIONAL	1	
2	13104ZF6W00	PISTON (0.75), OPTIONAL	1	
3	13111ZF6W00	PIN, PISTON	1	
4✖	13200ZE3010	ROD ASSY., CONNECTING (STD.)	1	INCLUDES ITEMS W/* SN 3177434 AND BELOW
4✖	13200ZE3020	ROD ASSY., CONNECTING (STD.)	1	INCLUDES ITEMS W/* SN 3177435 AND ABOVE
4✖	13200ZE3315	ROD ASSY., CONNECTING (US 0.25)	1	INCLUDES ITEMS W/*
4◇	13200ZE3020	ROD ASSY., CONNECTING (STD.)	1	INCLUDES ITEMS W/*
4◇	13200ZE3315	ROD ASSY., CONNECTING (US 0.25)	1	INCLUDES ITEMS W/*
5*	90001ZE8000	BOLT, CONNECTING ROD	2	
6	90601ZE3000	CLIP, PISTON PIN 20MM	2	

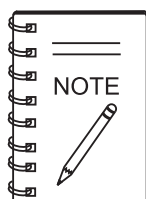

- ✖ GX390K1QA2: Model WM120 December 2006 And Below
- ◇ GX340U1QA2: Model WM120 January 2007 And Above

HONDA GX390K1QA2/GX390U1QA2 — CRANKCASE COVER ASSY.

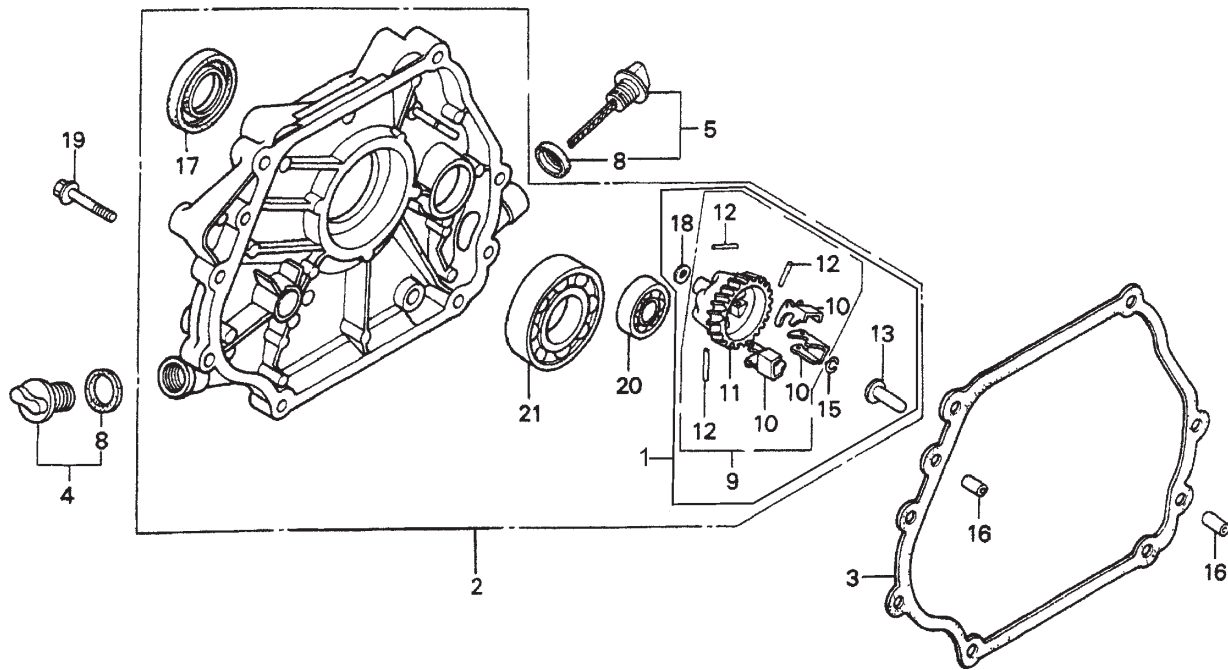

HONDA GX390K1QA2/GX390U1QA2 — CRANKCASE COVER ASSY.

NO.	PART NO.	PART NAME	QTY.	REMARKS
1*	06165ZE3000	GOVERNOR KIT (OPIONAL)	1	INCLUDES ITEMS W/#
2✘	11300ZE3602	COVER ASSY., CRANKCASE (Q TYPE)	1	INCLUDES ITEMS W/* S/N 3287256 AND BELOW
2✘	11300ZE3604	COVER ASSY., CRANKCASE (Q TYPE)	1	INCLUDES ITEMS W/* S/N 3287257 AND ABOVE
2◇	11300ZE3604	COVER ASSY., CRANKCASE (Q TYPE)	1	
3✘	11381ZE3800	GASKET, CASE COVER	1	S/N 2949254 AND BELOW
3✘	11381ZE3801	GASKET, CASE COVER	1	S/N 2949255 AND ABOVE
3◇	11381ZE3801	GASKET, CASE COVER	1	
4	15600ZG4003	CAP ASSEMBLY, OIL FILLER	1	INCLUDES ITEMS W/%
5	15600735003	CAP ASSEMBLY, OIL FILLER	1	INCLUDES ITEMS W/%
8%	15625ZE1003	GASKET, OIL FILLER CAP	2	
9*#	16510ZE3000	GOVERNOR ASSEMBLY	1	INCLUDES ITEMS W/+
10*#+	16511ZE8000	WEIGHT, GOVERNOR	3	
11*#+	16512ZE3000	HOLDER, GOVERNOR WEIGHT	1	
12*#+	16513ZE2000	PIN, GOVERNOR WEIGHT	3	
13✘ *#	16531ZE2000	SLIDER, GOVERNOR	1	S/N 3287256 AND BELOW
13✘ *#	16531Z0A000	SLIDER, GOVERNOR	1	S/N 3287257 AND ABOVE
13◇*#	16531Z0A000	SLIDER, GOVERNOR	1	
15*#	90602ZE1000	CLIP, GOVERNOR HOLDER	1	
16	90701HC4000	PIN, DOWEL 8X12	2	
17*	91201ZE3004	OIL SEAL 36X52X8	1	
18*#	9410106800	WASHER, PLAIN 6MM	1	
19	957010804000	BOLT, FLANGE 8X40	7	
20*	961006202000	BEARING, RADIAL BALL 6202	1	
21*	961006207000	BEARING, RADIAL BALL 6207	1	



- ✘ GX390K1QA2: Model WM120 December 2006 And Below
- ◇ GX340U1QA2: Model WM120 January 2007 And Above

HONDA GX390K1QA2/GX390U1QA2 — CRANKSHAFT ASSY.

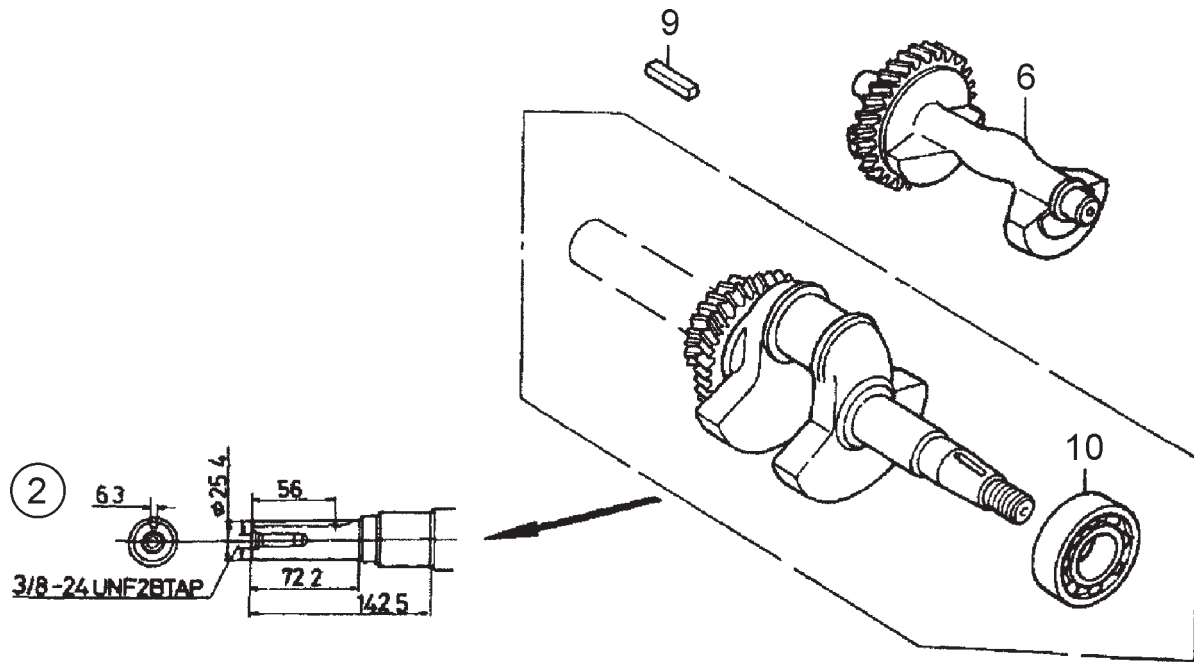

HONDA GX390K1QA2/GX390U1QA2 — CRANKSHAFT ASSY.

<u>NO.</u>	<u>PART NO.</u>	<u>PART NAME</u>	<u>QTY.</u>	<u>REMARKS</u>
2✕	13310ZF6W10	CRANKSHAFT, Q-TYPE	1	INCLUDES ITEMS W/*
2◇	13310ZF6W11	CRANKSHAFT COMP.	1	S/N 1113739 AND BELOW
2◇	13310ZF6W12	CRANKSHAFT COMP.	1	S/N 1113740 AND ABOVE
6	13351ZE3010	WEIGHT, BALANCER	1	
9	90745ZE2600	KEY 6.3X6.3X43	1	
10✕*	91001ZF6003	BEARING, RADIAL BALL 6207S	1	
10◇*	91001ZF6003	BEARING, RADIAL BALL 6207S	1	S/N 1113739 AND BELOW
10◇*	91001ZF6013	BEARING, RADIAL BALL 6207SH	1	S/N 1113740 AND ABOVE

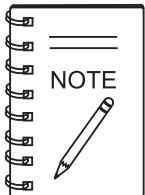

- ✕ GX390K1QA2: Model WM120 December 2006 And Below
- ◇ GX340U1QA2: Model WM120 January 2007 And Above

HONDA GX390K1QA2/GX390U1QA2 — CYLINDER BARREL ASSY.

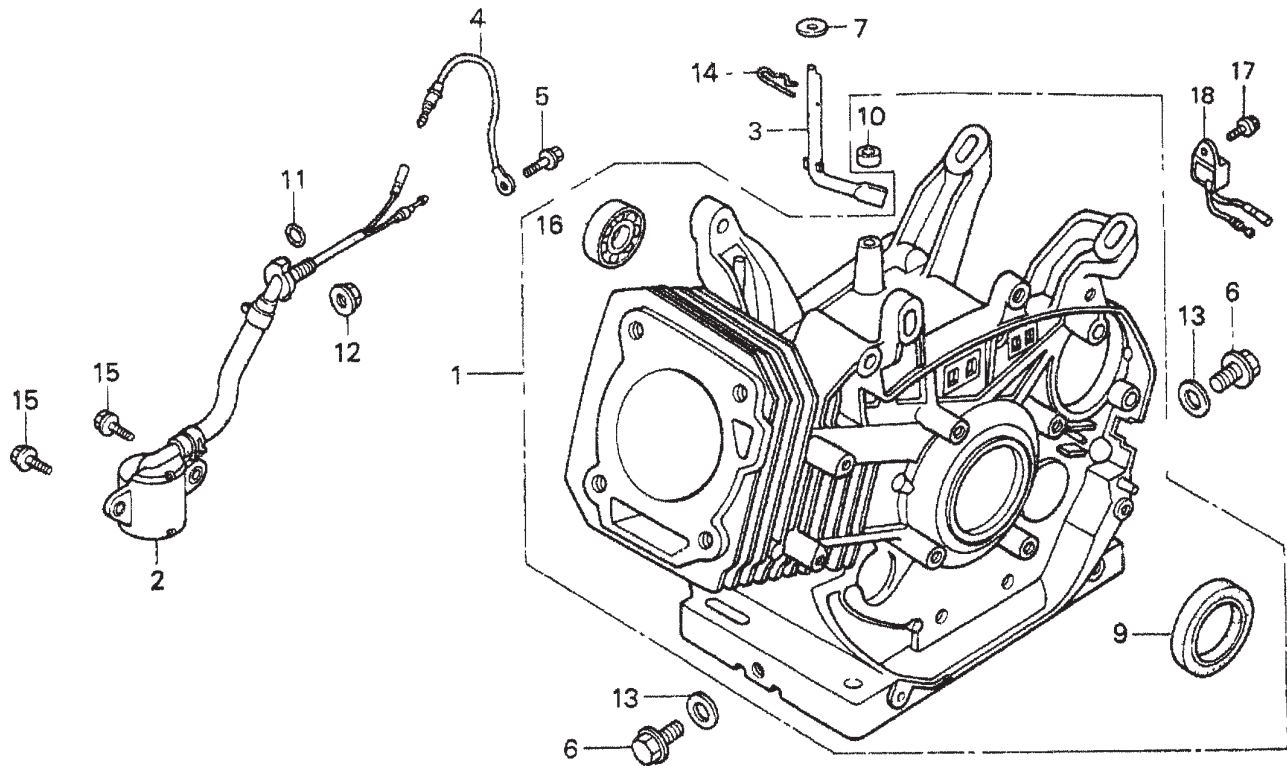

HONDA GX390K1QA2/GX390U1QA2 — CYLINDER BARREL ASSY.

NO.	PART NO.	PART NAME	QTY.	REMARKS
1✖	12000ZF6W12	BARREL ASSY., CYL. ALERT OIL	1	INCLUDES ITEMS W/* SN 3020570 AND BELOW
1✖	12000ZF6W13	BARREL ASSY., CYL. ALERT OIL	1	INCLUDES ITEMS W/* SN 3020571 AND ABOVE
1◇	12000ZF6417	BARREL ASSY., CYL. ALERT OIL	1	INCLUDES ITEMS W/*
2✖	15510ZE2023	SWITCH ASSY., OIL LEVEL	1	S/N 2334667 AND BELOW
2✖	15510ZE2033	SWITCH ASSY., OIL LEVEL	1	2334668 ~ 2456575
2✖	15510ZE2043	SWITCH ASSY., OIL LEVEL	1	REPLACES 15510ZE2033 S/N 2456576 AND ABOVE
2◇	15510ZE2043	SWITCH ASSY., OIL LEVEL	1	REPLACES 15510ZE2033 S/N 1412956 AND BELOW
2◇	15510ZE2053	SWITCH ASSY., OIL LEVEL	1	S/N 1412957 AND ABOVE
3	16541ZE3010	SHAFT, GOVERNOR ARM	1	
4✖	32197ZE2003	SUB-HARNESS	1	USE UP TO ENGINE SN 2334667
5✖	90013883000	BOLT, FLANGE 6X12 (CT200)	1	USE UP TO ENGINE SN 2334667
6	90131883000	BOLT, DRAIN PLUG 12 X 15	2	
7	90446KE1000	WASHER 8.2X17X0.8	1	
9*	91201ZE3004	OIL SEAL 35X52X8	1	
10*	91203952771	OIL SEAL 8X14X5	1	
11	91353671004	O- RING 13.5X1.5 (ARAI)	1	
12	9405010000	NUT, FLANGE 10mm.	1	
13	9410912000	WASHER, DRAIN PLUG 12mm.	2	
14	9425110000	PIN, LOCK 10mm.	1	
15	957010601200	BOLT, FLANGE 6X12	2	
16*	961006202000	BEARING, RADIAL BALL 6202	1	
17✖	90013883000	BOLT, FLANGE 6X12 (CT200)	1	USE FROM ENGINE SN 2468555
17◇	90013883000	BOLT, FLANGE 6X12 (CT200)	1	
18✖	34150ZH7003	ALERT UNIT, OIL	1	USE FROM ENGINE SN 2468555
18◇	34150ZH7003	ALERT UNIT, OIL	1	S/N 1419413 AND BELOW
18◇	34150ZH7013	ALERT UNIT, OIL	1	S/N 1419414 AND ABOVE

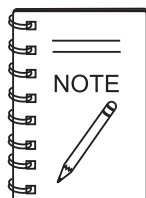

- ✖ GX390K1QA2: Model WM120 December 2006 And Below
- ◇ GX340U1QA2: Model WM120 January 2007 And Above

HONDA GX390K1QA2/GX390U1QA2 — CYLINDER HEAD ASSY.

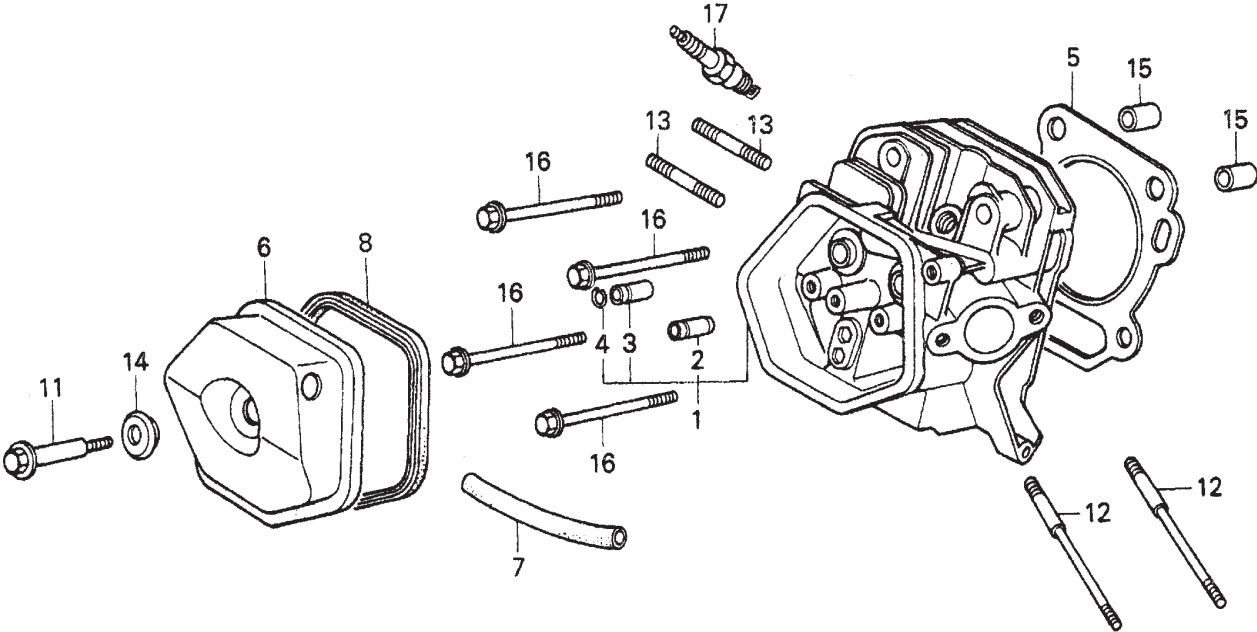

HONDA GX390K1QA2/GX390U1QA2 — CYLINDER HEAD ASSY.

NO.	PART NO.	PART NAME	QTY.	REMARKS
1✘	12200ZF6W01	CYLINDER HEAD	1	INCLUDES ITEMS W/*
1◇	12200ZF6406	CYLINDER HEAD	1	INCLUDES ITEMS W/*
2*	12204ZE2306	GUIDE, VALVE OS (OPTIONAL)	1	
3*	12205ZE2305	GUIDE, EX. VALVE OS (OPTIONAL)	1	
4*	12216ZE2300	CLIP, VALVE GUIDE	1	
5	12251ZF6W00	GASKET, CYLINDER HEAD	1	
6✘	12310ZE3791	COVER, HEAD	1	SN 2378736 AND BELOW
6✘	12310ZE2020	COVER, HEAD	1	SN 2378737 AND ABOVE
6◇	12310ZE2020	COVER, HEAD	1	
7◇	950051110530	TUBE, 11X105	1	REPL. 950051100130M
7✘	950051110530	TUBE, 11X105	1	SN 2368041 AND BELOW REPL. 950051100130M
7✘	12315ZE3840	TUBE, BREATHER	1	SN 2368042 AND ABOVE
8	12391ZE2020	GASKET, CYLINDER HEAD COVER	1	
11	90014ZE2000	BOLT, HEAD COVER	1	
12	90042ZE8000	BOLT, STUD 8X131.5	2	
13✘	90047ZE2000	BOLT 2, STUD 8X47	2	S/N 2638033 AND BELOW
13✘	92900080320E	BOLT 2, STUD 8X32	2	REPLACES 90047ZE2000 S/N 2638034 AND ABOVE
13◇	92900080320E	BOLT 2, STUD 8X32	2	
14	90441ZE2010	WASHER, HEAD COVER	1	
15	9430112200	PIN A, DOWEL 12X20	2	
16✘	957251008000	BOLT, FLANGE 10X80	4	
16◇	957251008000	BOLT, FLANGE 10X80	4	S/N 1411816 AND BELOW
16◇	957011008000	BOLT, FLANGE 10X80	4	S/N 1411817 AND ABOVE
17	9807955846	SPARK PLUG BPR5ES (NGK), OPT.	1	
17	9807955855	SPARK PLUG W16EPR-U (DENSO), OPT.	1	
17	9807956846	SPARK PLUG BPR6ES (NGK)	1	
17	9807956855	SPARK PLUG W20EPR-U (DENSO)	1	

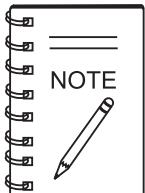

- ✘ GX390K1QA2: Model WM120 December 2006 And Below
- ◇ GX340U1QA2: Model WM120 January 2007 And Above

HONDA GX390K1QA2/GX390U1QA2 — FAN COVER ASSY.

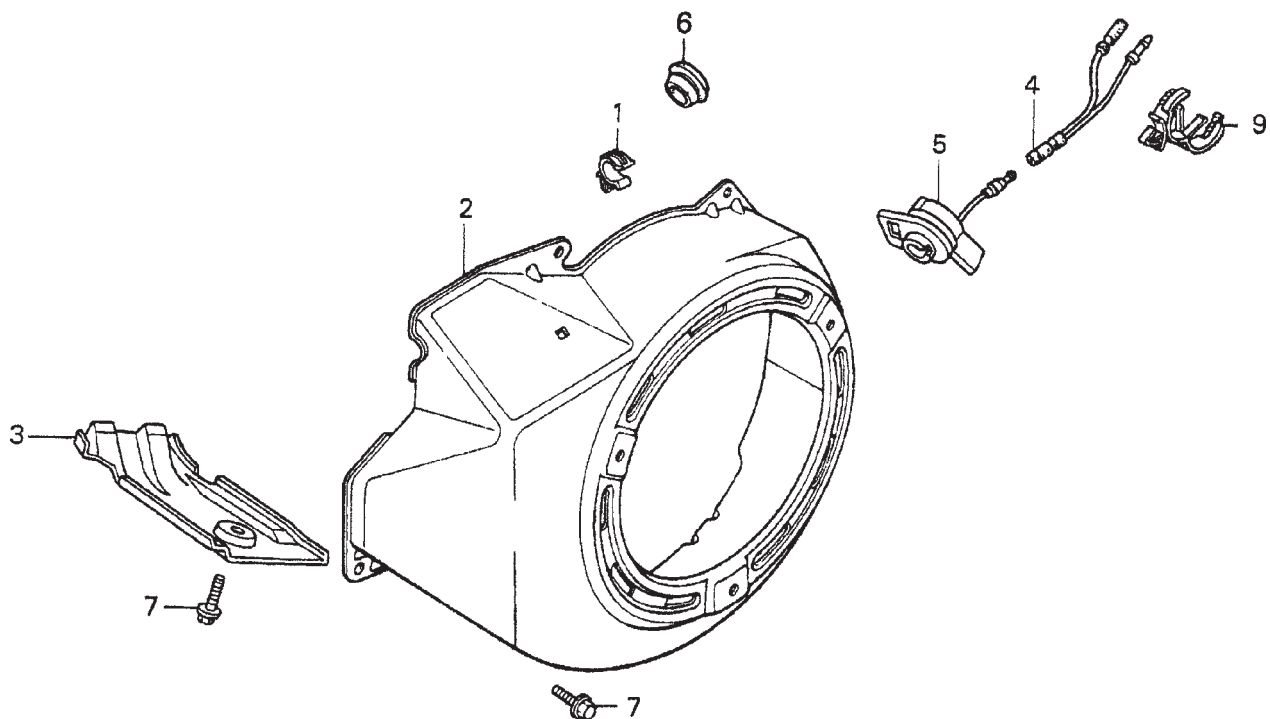

HONDA GX390K1QA2/GX390U1QA2 — FAN COVER ASSY.

<u>NO.</u>	<u>PART NO.</u>	<u>PART NAME</u>	<u>QTY.</u>	<u>REMARKS</u>
1	16731ZE2003	CLIP, TUBE	1	
2	19610ZE3010ZA	COVER, FAN *R280*, RED	1	
3	19631ZE3W00	SHROUD	1	
4✖	32197ZH8003	SUB-HARNESS	1 SN 2334667 AND BELOW
5✖	36100ZE1015	SWITCH ASSY., ENGINE STOP	1 SN 2334667 AND BELOW
5✖	36100ZH7003	SWITCH ASSY., ENGINE STOP	1 SN 2334668 AND ABOVE
5◇	36100ZF6P81	SWITCH ASSY., ENGINE STOP	1 SN 1412956 AND BELOW
5◇	36100ZF6P82	SWITCH ASSY., ENGINE STOP	1 SN 1412957 AND ABOVE
7	90013883000	BOLT, FLANGE 6X12 (CT200)	6	
9✖	90684ZA0601	CLIP, WIRE HARNESS	1	



- ✖ GX390K1QA2: Model WM120 December 2006 And Below
- ◇ GX340U1QA2: Model WM120 January 2007 And Above

HONDA GX390K1QA2/GX390U1QA2 — FLYWHEEL ASSY.

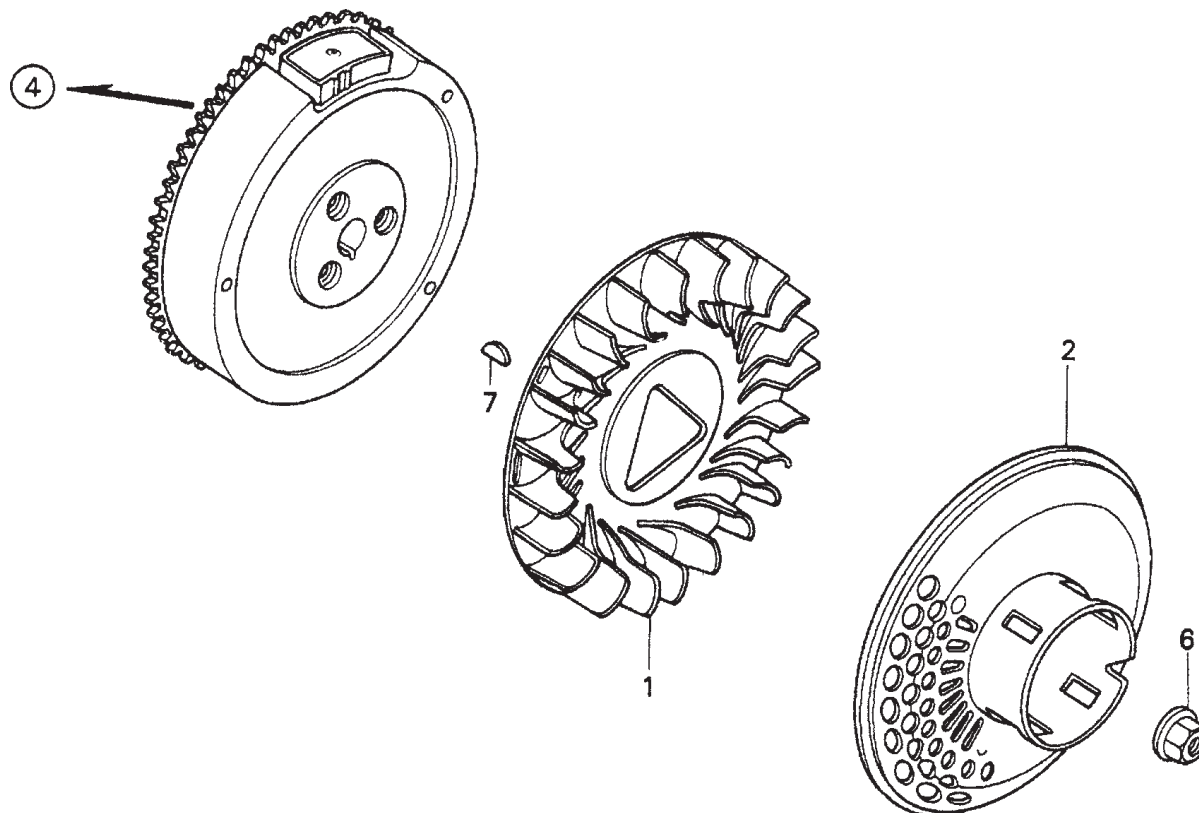

HONDA GX390K1QA2/GX390U1QA2 — FLYWHEEL ASSY.

<u>NO.</u>	<u>PART NO.</u>	<u>PART NAME</u>	<u>QTY.</u>	<u>REMARKS</u>
1	19511ZE3000	FAN, COOLING	1	
2	28450ZE3W11	PULLEY, STARTER (SCREEN GRID)	1	
4	31100ZE3701	FLYWHEEL	1	
6✘	90201ZE3790	NUT, SPECIAL 16MM	1	S/N 2263434 AND BELOW
6✘	90201ZE3V00	NUT, SPECIAL 16MM (1)	1	S/N 2263435 AND ABOVE
6◇	90201ZE3V00	NUT, SPECIAL 16MM (1)	1	S/N 1317976 AND BELOW
6◇	90201ZE3790	NUT, SPECIAL 16MM	1	S/N 1317977 AND ABOVE
7	90741ZE2000	KEY, SPECIAL WOODRUFF 25X18	1	

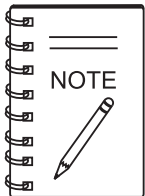

- ✘ GX390K1QA2: Model WM120 December 2006 And Below
- ◇ GX340U1QA2: Model WM120 January 2007 And Above

HONDA GX390K1QA2/GX390U1QA2 — IGNITION COIL ASSY.

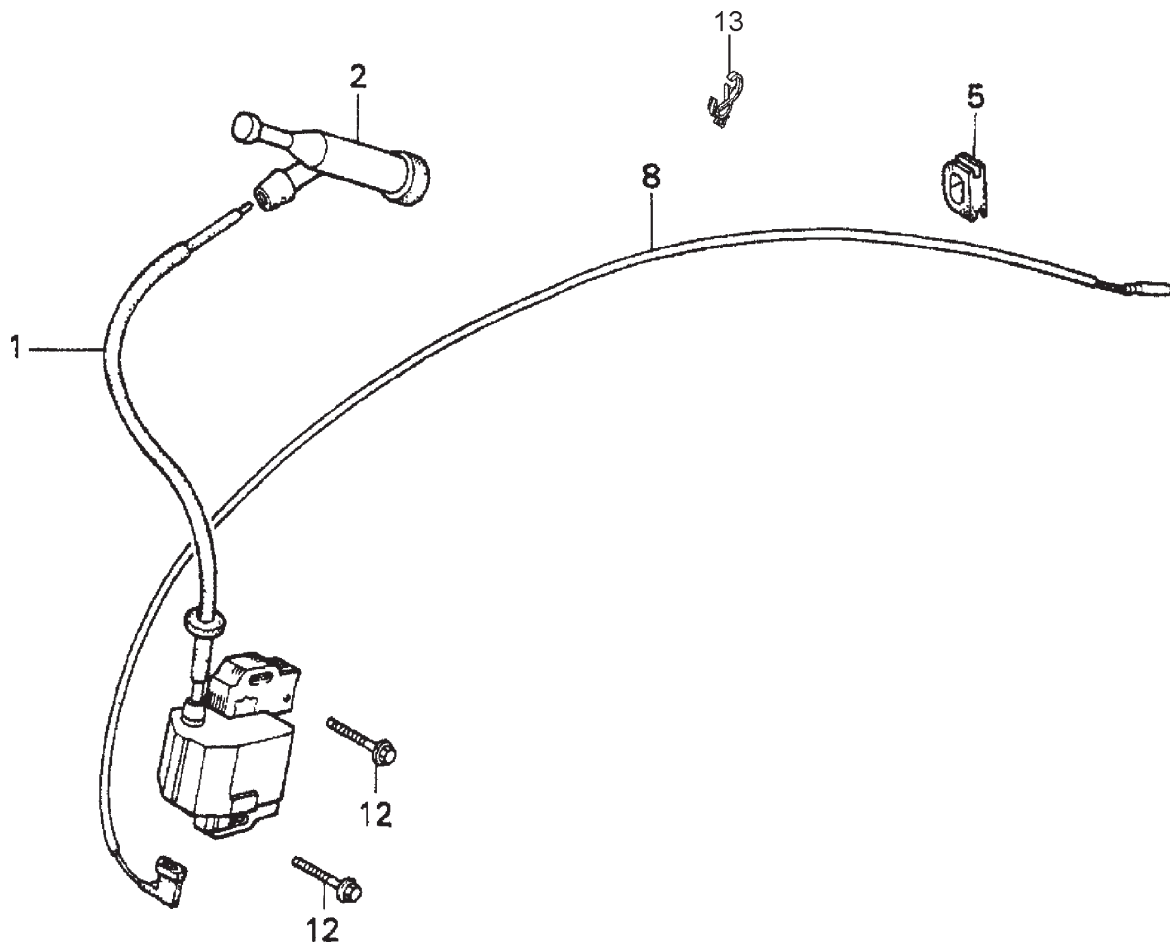

HONDA GX390K1QA2/GX390U1QA2 — IGNITION COIL ASSY.

<u>NO.</u>	<u>PART NO.</u>	<u>PART NAME</u>	<u>QTY.</u>	<u>REMARKS</u>
1✖	30500ZF6W02	COIL ASSEMBLY, IGNITION	1	REPLACES 305007E2023
1◇	30500ZF6W02	COIL ASSEMBLY, IGNITION	1	S/N 1411816 AND BELOW
1◇	30500ZF6W03	COIL ASSEMBLY, IGNITION	1	S/N 1411817 AND ABOVE
2	30700ZE1013	CAP ASSEMBLY, NOISE SUPPRESSOR	1	
5	31512ZE2000	GROMMET, WIRE	1	
8	36101ZE2701	WIRE, STOP SWITCH 430MM	1	
12	90015883000	BOLT, FLANGE 6X28	2	
13◇	90684ZA0601	CLIP, HARNESS	1	



- ✖ GX390K1QA2: Model WM120 December 2006 And Below
- ◇ GX340U1QA2: Model WM120 January 2007 And Above

HONDA GX390K1QA2/GX390U1QA2 — CARBURETOR ASSY.

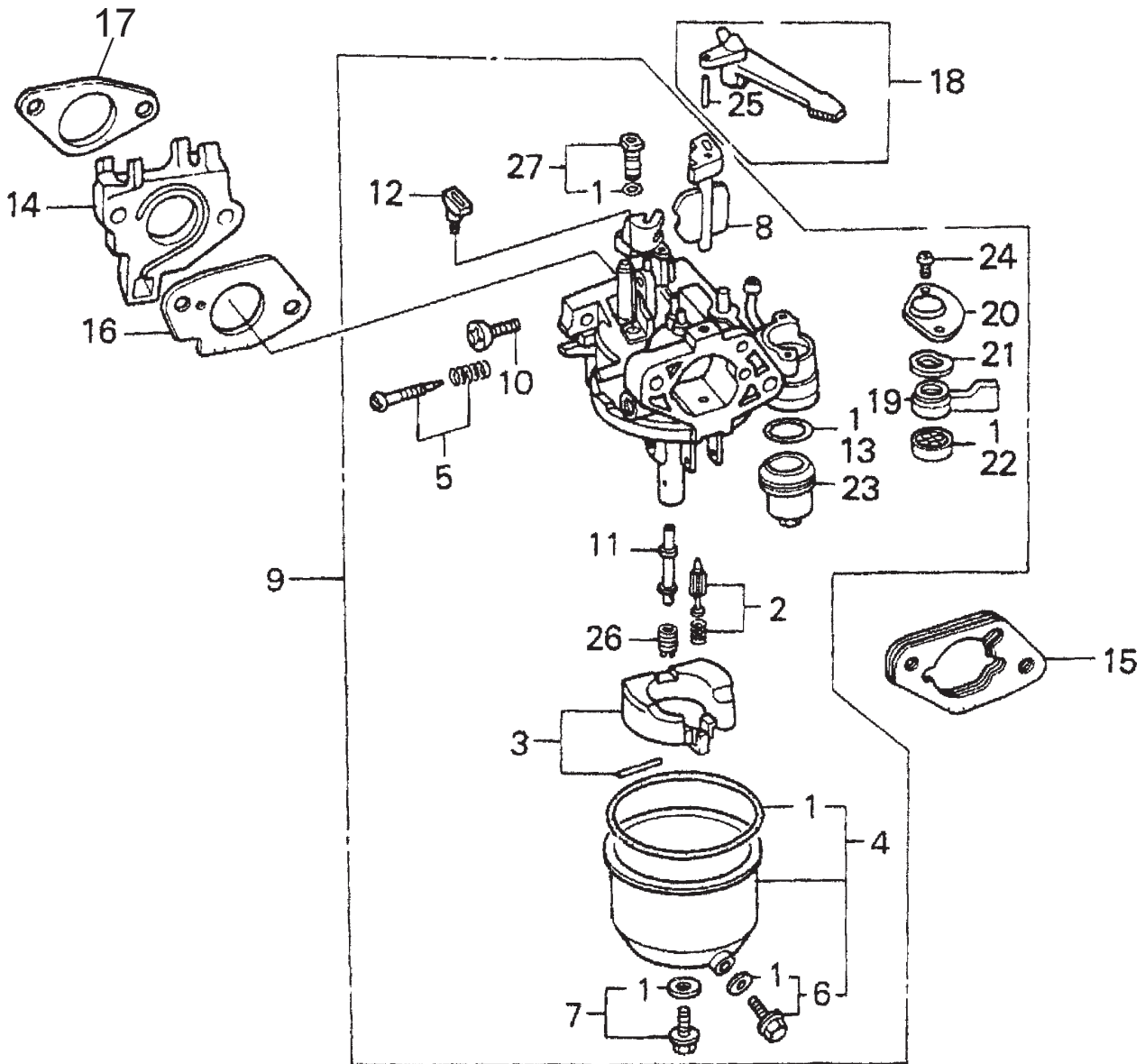

HONDA GX390K1QA2/GX390U1QA2 — CARBURETOR ASSY.

CARBURETOR ASSY.

NO.	PART NO.	PART NAME	QTY.	REMARKS
1#%	16010ZE2812	GASKET SET	1	INCLUDES ITEM W/&
2*	16011ZA0931	VALVE SET, FLOAT	1	
3*	16013ZA0931	FLOAT SET	1	
4**	16015ZE2005	CHAMBER SET, FLOAT	1	INCLUDES ITEMS W/% S/N BE85B A AND BELOW
4**	16015ZE8005	CHAMBER SET, FLOAT	1	INCLUDES ITEMS W/% S/N BE85B B AND ABOVE
4◇*	16015ZE8005	CHAMBER SET, FLOAT	1	
5*	16016ZH7W01	SCREW SET	1	
6*%	16024ZE1811	SCREW SET, DRAIN	1	INCLUDES ITEMS W/#
7*	16028ZE0005	SCREW SET B	1	INCLUDES ITEMS W/#
8*	16044ZE3W20	CHOKE SET	1	
9**	16100ZF6V00	CARBURETOR ASSY., BE85BA	1	INCLUDES ITEMS W/* S/N 2255423 AND BELOW
9**	16100ZF6V01	CARBURETOR ASSY., BE85B B	1	INCLUDES ITEMS W/* S/N 2255424 AND ABOVE
9◇	16100ZF6V01	CARBURETOR ASSY., BE85B B	1	INCLUDES ITEMS W/*
10*	16124ZE0005	SCREW, THROTTLE STOP	1	
11*	16166ZF6V00	NOZZLE, MAIN	1	
12*	16172ZE3W10	COLLAR, SET	1	
13*&	16173001004	GASKET, FUEL STRAINER CUP	1	
14	16211ZF6000	INSULATOR, CARBURETOR	1	
15	16220ZA0702	SPACER, CARBURETOR	1	
16	16221ZF6800	GASKET, CARBURETOR	1	
17	16223ZE3W00	GASKET, INSULATOR	1	
18	16610ZE1000	LEVER, CHOKE (STANDARD)	1	INCLUDES ITEMS W/+

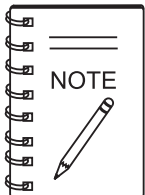

- ** GX390K1QA2: Model WM120 December 2006 And Below
- ◇ GX340U1QA2: Model WM120 January 2007 And Above

HONDA GX390K1QA2/GX390U1QA2 — MUFFLER ASSY.

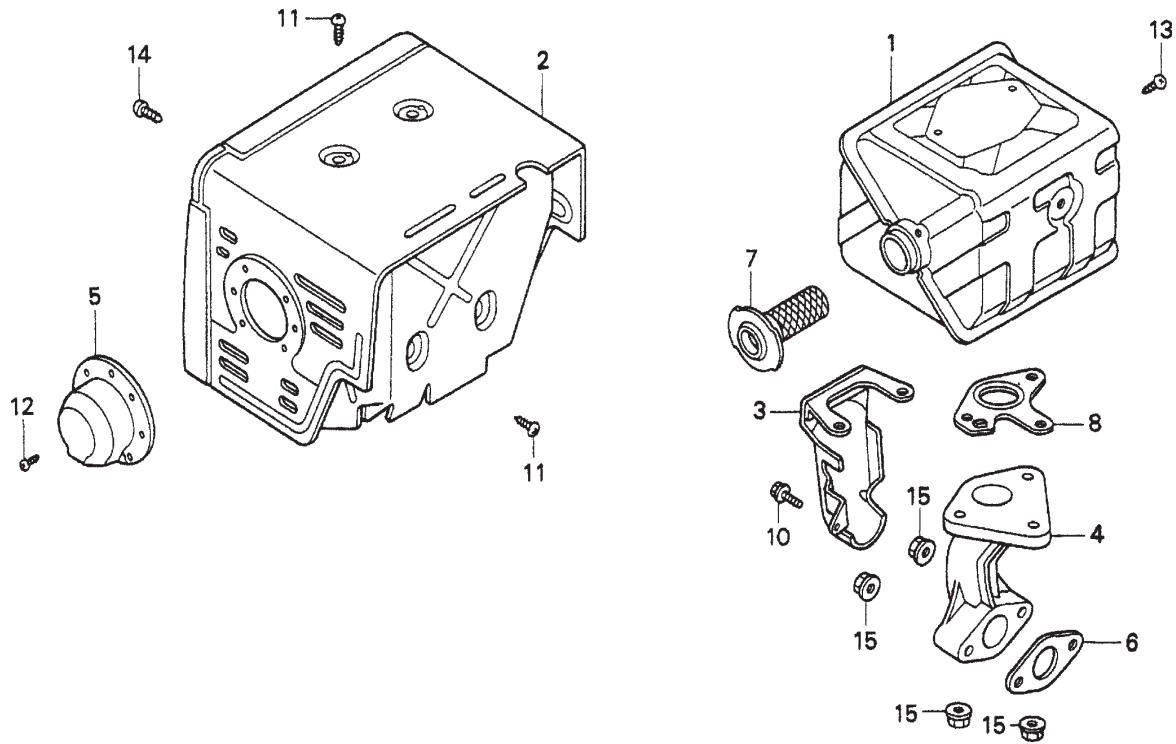

HONDA GX390K1QA2/GX390U1QA2 — MUFFLER ASSY.

<u>NO.</u>	<u>PART NO.</u>	<u>PART NAME</u>	<u>QTY.</u>	<u>REMARKS</u>
1	18310ZE2W61	MUFFLER 100DB	1	
2	18320ZE2W61	PROTECTOR, MUFFLER	1	
3	18323ZE3W40	PROTECTOR, EXHAUST PIPE	1	
4	18330ZE2W00	PIPE, EXHAUST	1	
5✖	18331ZE3810	CAP, MUFFLER	1	
5◇	18331ZE3810	CAP, MUFFLER	1	S/N 1166160 AND BELOW
5◇	18331ZE3811	CAP, MUFFLER	1	S/N 1166161 AND ABOVE
6✖	18333ZE3800	GASKET, EXHAUST PIPE	1	S/N 2275744 AND BELOW
6✖	18333ZK6Y00	GASKET, EXHAUST PIPE	1	2275745 ~ 2638033
6✖	18333ZF6W01	GASKET, EXHAUST PIPE	1	S/N 2638034 AND ABOVE
6◇	18333ZE6W01	GASKET, EXHAUST PIPE	1	
7	18355ZE2W00	ARRESTER, SPARK	1	
8	18381ZE2W10	GASKET, MUFFLER (ARRESTER)	1	
10	90013883000	BOLT, FLANGE 6X12 (CT200)	1	
11	90050ZE1000	SCREW, TAPPING 5X8	4	
12	90055ZE1000	SCREW, TAPPING 4X6	3	
13	90055ZE1000	SCREW, TAPPING 4X6	1	
14	90006ZE2000	SCREW, TAPPING 6X10	1	
15	9405008000	NUT, FLANGE 8MM	5	

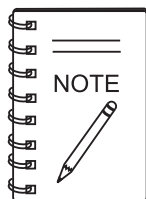

- ✖ GX390K1QA2: Model WM120 December 2006 And Below
- ◇ GX340U1QA2: Model WM120 January 2007 And Above

HONDA GX390K1QA2/GX390U1QA2 — RECOIL STARTER ASSY.

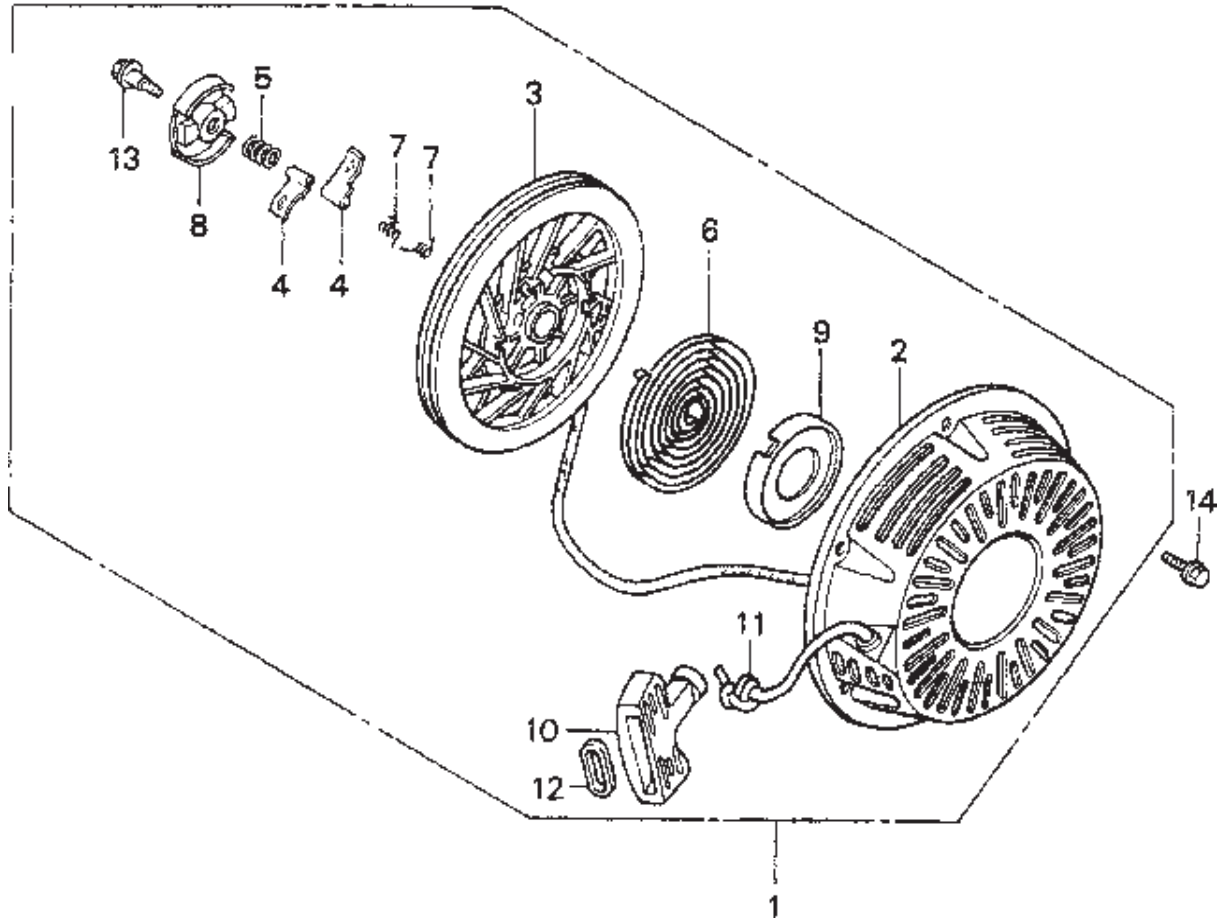

HONDA GX390K1QA2/GX390U1QA2 — RECOIL STARTER ASSY.

NO.	PART NO.	PART NAME	QTY.	REMARKS
1✘	28400ZE3W01ZA	STARTER ASSY., RECOIL *R8*, RED.	1	INCLUDES ITEMS W/*
1◇	28400ZE3W01ZP	STARTER ASSY., RECOIL *R280*, RED.	1	INCLUDES ITEMS W/*
2✘*	28410ZE3W01ZA	CASE, RECOIL STARTER *R8*, RED	1	
2◇*	28410ZE3W01ZP	CASE, RECOIL STARTER *R280*, RED	1	
3*	28421ZE3W01	PULLEY, RECOIL STARTER	1	
4*	28422ZE2W01	RATCHET, STARTER	2	
5*	28441ZE2W01	SPRING, FRICTION	1	
6*	28442ZE2W01	SPRING, STARTER RETURN	1	
7*	28443ZE2W01	SPRING, RATCHET	2	
8*	28444ZE2W01	RETAINER, SPRING	1	
9*	28445ZE2W01	HOLDER, SPRING	1	
10*	28461ZE2W02	GRIP, STARTER	1	
11*	28462ZE3W01	ROPE, RECOIL STARTER	1	
12◇*	28469ZE2W01	GRIP, REINFORCEMENT	1	UP TO ENG. S/N 584635
13*	90004ZE2W01	SCREW, CENTER	1	
14	90008ZE2003	BOLT, FLANGE 6X10	3	

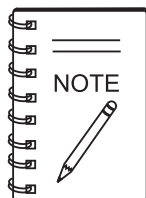

- ✘ GX390K1QA2: Model WM120 December 2006 And Below
- ◇ GX340U1QA2: Model WM120 January 2007 And Above

HONDA GX390K1QA2/GX390U1QA2— CONTROL ASSY.

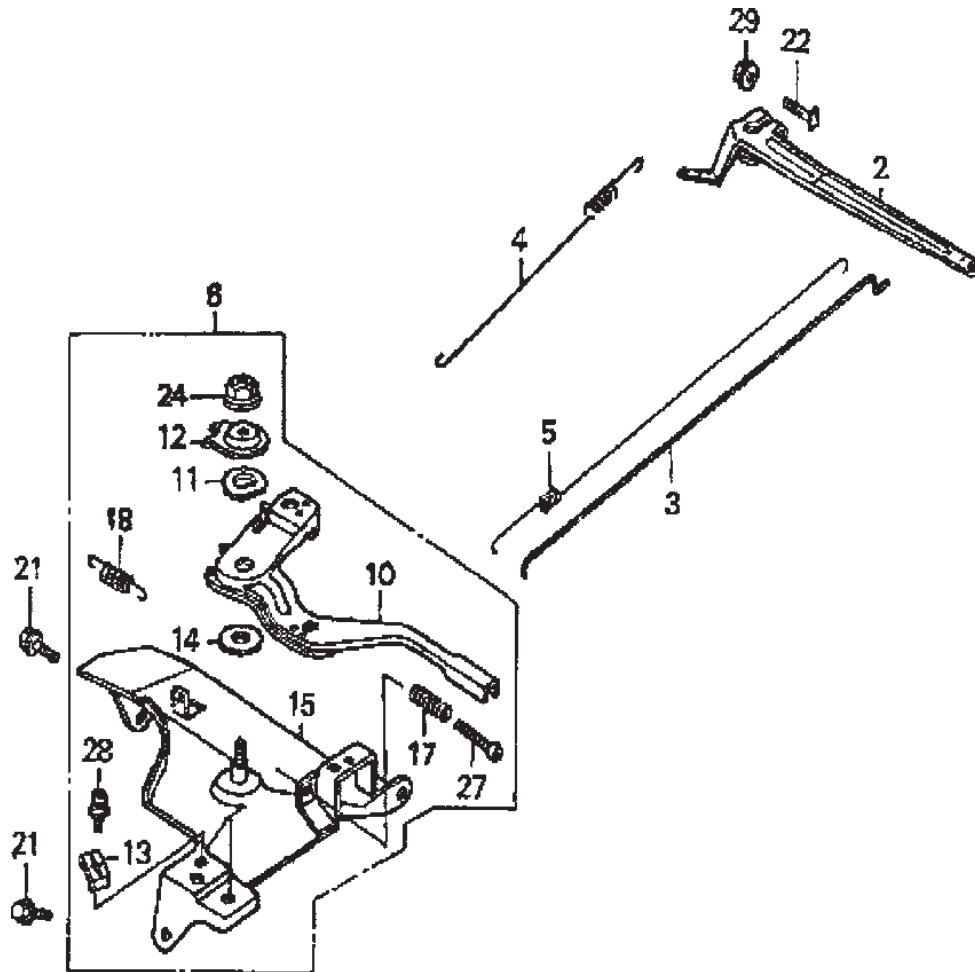

HONDA GX390K1QA2/GX390U1QA2— CONTROL ASSY.

<u>NO.</u>	<u>PART NO.</u>	<u>PART NAME</u>	<u>QTY.</u>	<u>REMARKS</u>
2	16551ZE3000	ARM, GOVERNOR	1	
3	16555ZE3000	ROD, GOVERNOR	1	
4	16561ZE3000	SPRING, GOVERNOR	1	
5	16562ZE3000	SPRING, THROTTLE RETURN	1	
6	16570ZE3W20	CONTROL ASSEMBLY, REMOTE	1	INCLUDES ITEMS W/*
10*	16571ZE3W00	LEVER, CONTROL	1	
11*	16574ZE1000	SPRING, LEVER	1	
12*	1675ZE2W00	WASHER, CONTROL LEVER	1	
13*	16576891000	HOLDER, CABLE	1	
14*	16578ZE1000	SPACER, CONTROL LEVER	1	
15*	16581ZE3W00	BASE, CONTROL (###)	1	
17*	16584883300	SPRING, CONTROL ADJUSTING	1	
18*	16592883310	SPRING, CABLE RETURN	1	
21	90013883000	BOLT, FLANGE (6X12) (CT200)	2	
22	90015ZE5010	BOLT, GOVERNOR ARM	1	
24*	90114SA0000	NUT, SELF-LOCK (6MM)	1	
27*	93500050320A	SCREW, PAN (5X32)	1	
28*	93500050160A	SCREW, PAN (5X16)	1	
29	9405006000	NUT, FLANGE (6MM)	1	

HONDA GX390K1QA2/GX390U1QA2 — FUEL TANK ASSY.

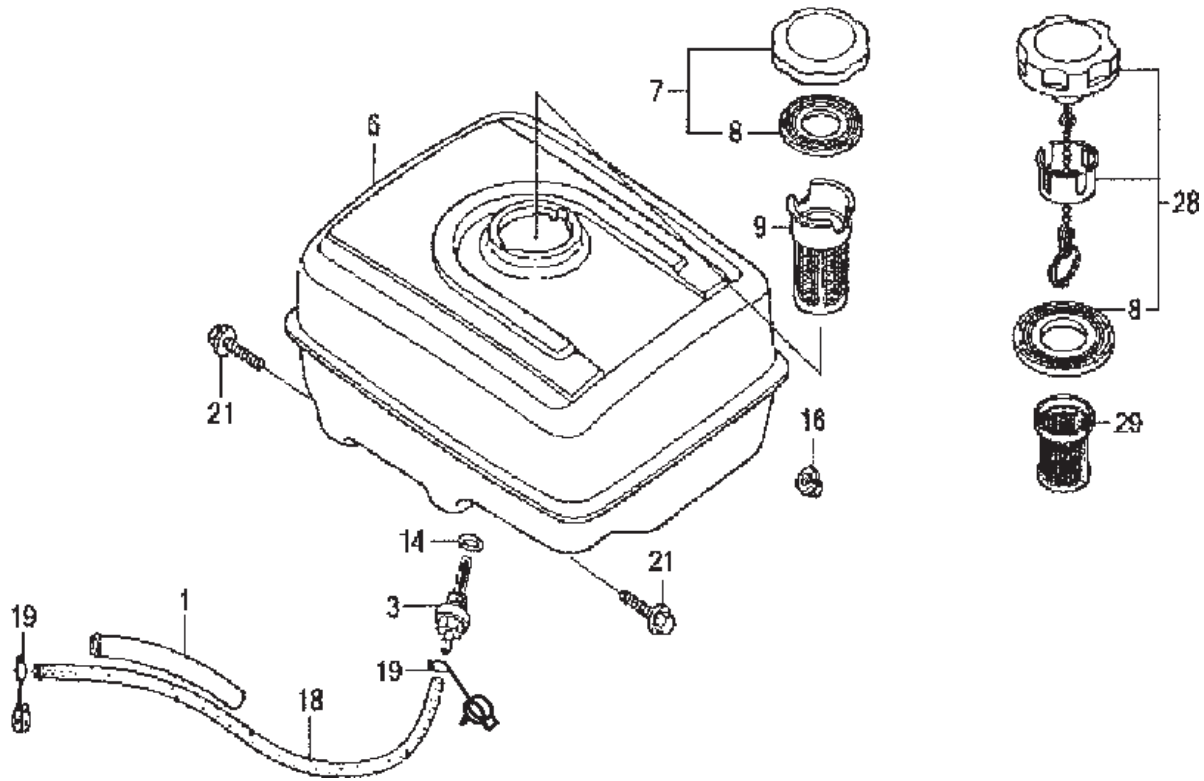

HONDA GX390K1QA2/GX390U1QA2 — FUEL TANK ASSY.

NO.	PART NO.	PART NAME	QTY.	REMARKS
1	16854ZH8000	RUBBER, SUPPORTER (107MM)	1	
3	16955ZE1000	JOINT, FUEL TANK	1	
6✖	17510ZE3010ZA	TANK, FUEL *NH31*	1	
6✖	17510ZE3010ZB	TANK, FUEL *NH1*	1	
6✖	17510ZE3010ZA	TANK, FUEL *T34*	1	
6◇	17510ZE3020ZA	TANK, FUEL *NH31*	1	S/N 1213085 AND BELOW
6◇	17510ZE3020ZB	TANK, FUEL *NH1*	1	S/N 1213085 AND BELOW
6◇	17510ZE3020ZD	TANK, FUEL *T34*	1	S/N 1213085 AND BELOW
6◇	17510ZE3800ZA	TANK, FUEL *NH1*	1	1213086 ~ 1383799
6◇	17510ZE3800ZC	TANK, FUEL *NH31*	1	1213086 ~ 1383799
6◇	17510ZE3800ZE	TANK, FUEL *T34*	1	1213086 ~ 1383799
6◇	17510ZE3801ZA	TANK, FUEL *NH1*	1	S/N 1383800 AND ABOVE
6◇	17510ZE3801ZC	TANK, FUEL *NH31*	1	S/N 1383800 AND ABOVE
6◇	17510ZE3801ZE	TANK, FUEL *T34*	1	S/N 1383800 AND ABOVE
7✖	17620ZH013	CAP COMP., FUEL FILLER	1	S/N 1383800 AND ABOVE
7✖	17620ZH023	CAP COMP., FUEL FILLER (BLACK)	1	S/N 1383800 AND ABOVE
7◇	17620Z0T305	CAP COMP., FUEL FILLER	1	S/N 1530148 AND BELOW (CHROME PLATED)
8✖	17631ZH7003	FUEL, FILLER CAP (39X58X3)	1	
8◇	17631Z0T812	FUEL, FILLER CAP (39X62X3)	1	S/N 1530148 AND BELOW
8◇	17631Z4H800	FUEL, FILLER CAP (39X62X3)	1	S/N 1530149 ~ 1552033
8◇	17631Z0T801	FUEL, FILLER CAP (39X62X3)	1	S/N 1552034 AND ABOVE
9✖	17672ZE2W01	FILTER, FUEL	1	
9◇	17672ZE2W01	FILTER, FUEL	1	S/N 1530148 AND BELOW
14	91353671004	O-RING 14MM (NOK)	1	
16	9405008000	NUT, FLANGE 8MM	2	
18✖	950014523540	TUBE, FUEL 4.5 X 235	1	REPL. 950014500160M
18◇	950014523540	TUBE, FUEL 4.5 X 235	1	S/N 1105013 AND BELOW REPL. 950014500160M
18◇	91424Z5L801	TUBE, FUEL 4.5 X 235 (FKM)	1	S/N 1105014 AND ABOVE
19✖	9500202080	CLIP, TUBE (B8)	2	
19◇	9500202080	CLIP, TUBE (B8)	2	S/N 1105013 AND BELOW
19◇	950024080008	CLAMP, TUBE (D8)	2	S/N 1105014 AND ABOVE
21	957010802500	BOLT, FLANGE 8 X 25	2	
28◇	17620Z4H010	CAP COMP., FUEL FILLER	1	1530149 ~ 1552033
28◇	17620Z4H020	CAP COMP., FUEL FILLER	1	1552034 AND ABOVE
29◇	17672Z4H000	FILTER, FUEL	1	1530149 AND ABOVE

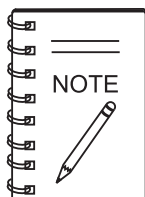

- ✖ GX390K1QA2: Model WM120 December 2006 And Below
- ◇ GX340U1QA2: Model WM120 January 2007 And Above

HONDA GX390K1QA2 — GASKET KIT ASSY.

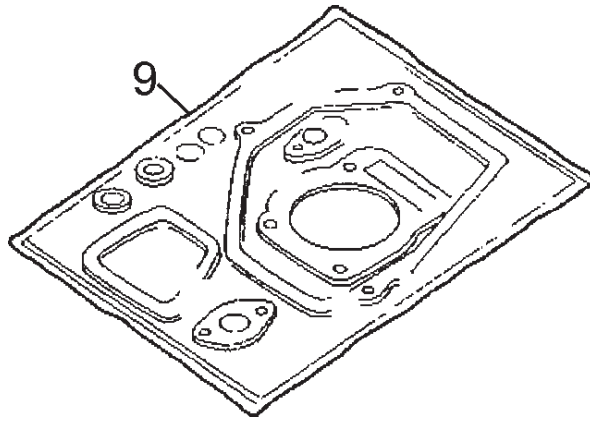

HONDA GX390K1QA2 — GASKET KIT ASSY.

<u>NO.</u>	<u>PART NO.</u>	<u>PART NAME</u>	<u>QTY.</u>	<u>REMARKS</u>
1*	11381ZE3800	GASKET, CASE COVER	1	
3*	12251ZF6W00	GASKET, CYLINDER HEAD	1	
4*	12391ZE2020	GASKET, CYLINDER HEAD COVER	1	
5*	16221ZF6800	GASKET, CARBURETOR	1	
6*	16223ZE3W00	GASKET, INSULATOR	1	
7*	18333ZF6W01	GASKET, EXHAUST PIPE	1	
8*	18381ZE2W10	GASKET, MUFFLER (ARRESTER)	1	
9	061A1Z6700	GASKET KIT	1	INCLUDES ITEMS W/* REPLACES 06111ZF6407 S/N 2949254

HONDA GX390K1QA2/GX390U1QA2 — LABELS ASSY.

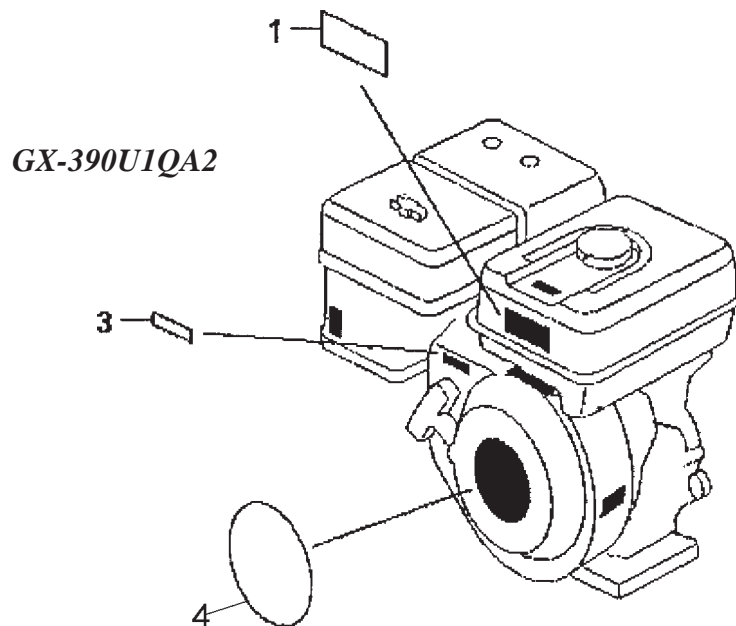
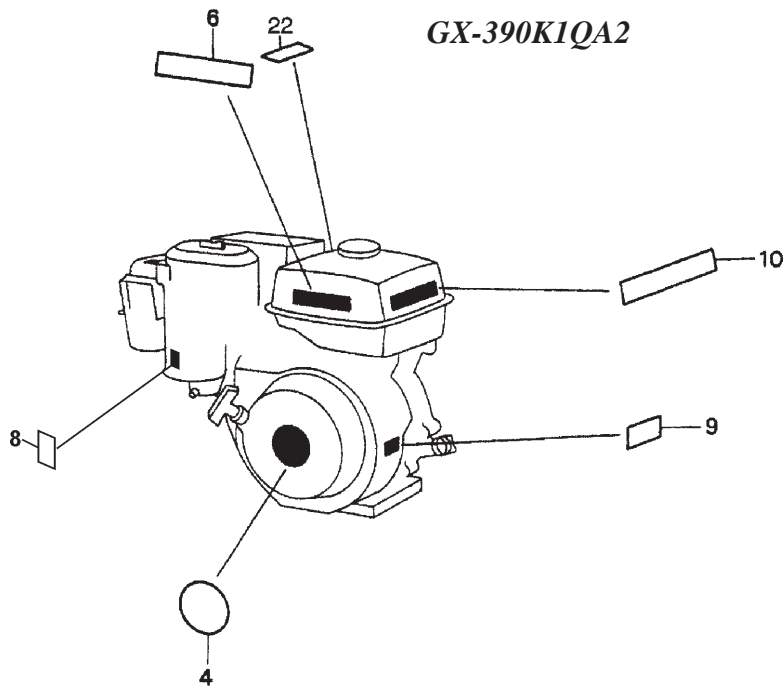

HONDA GX390K1QA2/GX390U1QA2 — LABELS ASSY.

<u>NO.</u>	<u>PART NO.</u>	<u>PART NAME</u>	<u>QTY.</u>	<u>REMARKS</u>
1◇	87516ZH7000	MARK, OPERATOR	1	
3◇	87532ZH7000	MARK,, THROTTLE INDICATION	1	
4✘	87521ZF6W01	EMBLEM	1	S/N 3249629 AND BELOW
4✘	87521ZF6W02	EMBLEM	1	S/N 3249630 AND ABOVE
4◇	87521ZF6W03	EMBLEM	1	S/N 1398206 AND BELOW
4◇	87521ZF6W04	EMBLEM	1	S/N 1398207 AND ABOVE
6✘	87522ZH9010	LABEL, CAUTION	1	
8✘	87528ZE2810	MARK, CHOKE (ORANGE)	1	
9✘	87530ZF6W10	LABEL, SPECIFICATION	1	TO ENGINE S/N 2172909
10✘	87532ZH8810	MARK, OIL ALERT (E)	1	
22✘	87586ZH7W00	LABEL, FUEL CAUTION	1	TO ENGINE S/N 2166102



- ✘ GX390K1QA2: Model WM120 December 2006 And Below
- ◇ GX340U1QA2: Model WM120 January 2007 And Above

TERMS AND CONDITIONS OF SALE — PARTS

PAYMENT TERMS

Terms of payment for parts are net 30 days.

FREIGHT POLICY

All parts orders will be shipped collect or prepaid with the charges added to the invoice. All shipments are F.O.B. point of origin. Multiquip's responsibility ceases when a signed manifest has been obtained from the carrier, and any claim for shortage or damage must be settled between the consignee and the carrier.

MINIMUM ORDER

The minimum charge for orders from Multiquip is \$15.00 net. Customers will be asked for instructions regarding handling of orders not meeting this requirement.

RETURNED GOODS POLICY

Return shipments will be accepted and credit will be allowed, subject to the following provisions:

1. A Returned Material Authorization must be approved by Multiquip prior to shipment.
2. To obtain a Return Material Authorization, a list must be provided to Multiquip Parts Sales that defines item numbers, quantities, and descriptions of the items to be returned.
 - a. The parts numbers and descriptions must match the current parts price list.
 - b. The list must be typed or computer generated.
 - c. The list must state the reason(s) for the return.
 - d. The list must reference the sales order(s) or invoice(s) under which the items were originally purchased.
 - e. The list must include the name and phone number of the person requesting the RMA.
3. A copy of the Return Material Authorization must accompany the return shipment.
4. Freight is at the sender's expense. All parts must be returned freight prepaid to Multiquip's designated receiving point.

5. Parts must be in new and resalable condition, in the original Multiquip package (if any), and with Multiquip part numbers clearly marked.
6. The following items are not returnable:
 - a. Obsolete parts. (If an item is in the price book and shows as being replaced by another item, it is obsolete.)
 - b. Any parts with a limited shelf life (such as gaskets, seals, "O" rings, and other rubber parts) that were purchased more than six months prior to the return date.
 - c. Any line item with an extended dealer net price of less than \$5.00.
 - d. Special order items.
 - e. Electrical components.
 - f. Paint, chemicals, and lubricants.
 - g. Decals and paper products.
 - h. Items purchased in kits.
7. The sender will be notified of any material received that is not acceptable.
8. Such material will be held for five working days from notification, pending instructions. If a reply is not received within five days, the material will be returned to the sender at his expense.
9. Credit on returned parts will be issued at dealer net price at time of the original purchase, less a 15% restocking charge.
10. In cases where an item is accepted, for which the original purchase document can not be determined, the price will be based on the list price that was effective twelve months prior to the RMA date.
11. Credit issued will be applied to future purchases only.

PRICING AND REBATES

Prices are subject to change without prior notice. Price changes are effective on a specific date and all orders received on or after that date will be billed at the revised price. Rebates for price declines and added charges for price increases will not be made for stock on hand at the time of any price change.

Multiquip reserves the right to quote and sell direct to Government agencies, and to Original Equipment Manufacturer accounts who use our products as integral parts of their own products.

SPECIAL EXPEDITING SERVICE

A \$35.00 surcharge will be added to the invoice for special handling including bus shipments, insured parcel post or in cases where Multiquip must personally deliver the parts to the carrier.

LIMITATIONS OF SELLER'S LIABILITY

Multiquip shall not be liable hereunder for damages in excess of the purchase price of the item with respect to which damages are claimed, and in no event shall Multiquip be liable for loss of profit or good will or for any other special, consequential or incidental damages.

LIMITATION OF WARRANTIES

No warranties, express or implied, are made in connection with the sale of parts or trade accessories nor as to any engine not manufactured by Multiquip. Such warranties made in connection with the sale of new, complete units are made exclusively by a statement of warranty packaged with such units, and Multiquip neither assumes nor authorizes any person to assume for it any other obligation or liability whatever in connection with the sale of its products. Apart from such written statement of warranty, there are no warranties, express, implied or statutory, which extend beyond the description of the products on the face hereof.

Effective: February 22, 2006

OPERATION AND PARTS MANUAL

HERE'S HOW TO GET HELP

PLEASE HAVE THE MODEL AND SERIAL
NUMBER ON-HAND WHEN CALLING

UNITED STATES

Multiquip Corporate Office

18910 Wilmington Ave. Tel. (800) 421-1244
Carson, CA 90746 Fax (800) 537-3927
Contact: mq@multiquip.com

Service Department

800-421-1244 Fax: 310-537-4259
310-537-3700

Technical Assistance

800-478-1244 Fax: 310-943-2238

MQ Parts Department

800-427-1244 Fax: 800-672-7877
310-537-3700 Fax: 310-637-3284

Warranty Department

800-421-1244 Fax: 310-943-2249
310-537-3700

MEXICO

MQ Cipsa

Carr. Fed. Mexico-Puebla KM 126.5 Tel: (52) 222-225-9900
Momoxpan, Cholula, Puebla 72760 Mexico Fax: (52) 222-285-0420
Contact: pmastretta@cipsa.com.mx

CANADA

Multiquip

4110 Industriel Boul. Tel: (450) 625-2244
Laval, Quebec, Canada H7L 6V3 Tel: (877) 963-4411
Contact: jmartin@multiquip.com Fax: (450) 625-8664

UNITED KINGDOM

Multiquip (UK) Limited Head Office

Unit 2, Northpoint Industrial Estate, Tel: 0161 339 2223
Globe Lane, Fax: 0161 339 3226
Dukinfield, Cheshire SK16 4UJ
Contact: sales@multiquip.co.uk

© COPYRIGHT 2011, MULTIQUIP INC.

Multiquip Inc, the MQ logo and the Whiteman logo are registered trademarks of Multiquip Inc. and may not be used, reproduced, or altered without written permission. All other trademarks are the property of their respective owners and used with permission.

This manual MUST accompany the equipment at all times. This manual is considered a permanent part of the equipment and should remain with the unit if resold.

The information and specifications included in this publication were in effect at the time of approval for printing. Illustrations, descriptions, references and technical data contained in this manual are for guidance only and may not be considered as binding. Multiquip Inc. reserves the right to discontinue or change specifications, design or the information published in this publication at any time without notice and without incurring any obligations.

Your Local Dealer is:



Free Manuals Download Website

<http://myh66.com>

<http://usermanuals.us>

<http://www.somanuals.com>

<http://www.4manuals.cc>

<http://www.manual-lib.com>

<http://www.404manual.com>

<http://www.luxmanual.com>

<http://aubethermostatmanual.com>

Golf course search by state

<http://golfingnear.com>

Email search by domain

<http://emailbydomain.com>

Auto manuals search

<http://auto.somanuals.com>

TV manuals search

<http://tv.somanuals.com>