

OPERATION AND PARTS MANUAL





MODELS **DA7000SS-DA7000SSA** **DA700SSW-DA7000WGH** **PORTABLE GENERATORS** **(KUBOTA Z482 SERIES DIESEL ENGINES)**

Revision #5 (01/20/11)

To find the latest revision of this
publication, visit our website at:
www.multiquip.com



THIS MANUAL MUST ACCOMPANY THE EQUIPMENT AT ALL TIMES.

 **WARNING** 

CALIFORNIA — Proposition 65 Warning

Diesel engine exhaust and some of its constituents are known to the State of California to cause cancer, birth defects and other reproductive harm.

REPORTING SAFETY DEFECTS

If you believe that your vehicle has a defect that could cause a crash or could cause injury or death, you should immediately inform the National Highway Traffic Safety Administration (NHTSA) in addition to notifying Multiquip at 1-800-421-1244.

If NHTSA receives similar complaints, it may open an investigation, and if it finds that a safety defect exists in a group of vehicles, it may order a recall and remedy campaign. However, NHTSA cannot become involved in individual problems between you, your dealer, or Multiquip.

To contact NHTSA, you may either call the Vehicle Safety Hotline toll-free at 1-888-327-4236 (TTY: 1-800-424-9153), go to <http://www.nhtsa.dot.gov>; or write to:

Administrator
NHTSA
1200 New Jersey Avenue S.E.
Washington, DC 20590

You can also obtain information about motor vehicle safety from
<http://www.safecar.gov>.

TABLE OF CONTENTS

DA7000 SERIES GENERATOR

Proposition 65 Warning	2
Reporting Safety Defects.....	3
Table Of Contents.....	4
Parts Ordering Procedures.....	5
Safety Information	6-11
Specifications (Generator).....	12
Specifications (Engine).....	13
Dimensions.....	14
Installation	16-17
General Information.....	18
Components (Generator).....	19-20
Components (Engine).....	21
Load Applications	22
Inspection/Setup.....	23-27
Operation.....	28-30
Shutdown.....	30
Preparation For Long Term Storage	31
Maintenance	32-35
Maintenance (Trailer).....	36-37
Trailer Guidelines.....	38-51
Trailer Wiring Digram	52
Generator Wiring Digram	53
Engine Wiring Digram	54
Troubleshooting (Engine and Generator)	55-56
Troubleshooting (Engine).....	57-58
Explanation Of Code In Remarks Column.....	60
Suggested Spare Parts	61

Component Drawings

Nameplate and Decals Assembly.....	62-63
Generator Assembly.....	64-65
Control Panel Assembly	66-67
Electric Parts Assembly.....	68-69
Engine And Radiator Assembly.....	70-73
Battery Assembly.....	74-75
Muffler Assembly.....	76-77
Fuel Tank Assembly.....	78-79
Oil Filter Retrofit Assembly	80-81
Enclosure Assembly	82-85
Rubber Seals Assembly	86-87

KUBOTA Z482-EB/E2B/E3B Diesel Engines

Crankcase Assembly	88-89
Oil Pump Assembly	90-91
Oil Pan Assembly	92-93
Cylinder Head Assembly	94-95
Gear Case Assembly	96-97
Head Cover Assembly	98-101
Oil Filter Assembly	102-103
Dipstick and Guide Assembly	104-105
Main Bearing Case Assembly	106-107
Camshaft and Idle Gear Assembly	108-109
Piston and Crankshaft Assembly	110-111
Flywheel Assembly	112-113
Fuel Camshaft and Gov. Shaft Assembly	114-115
Engine Stop Lever Assembly	116-117
Stop Solenoid Assembly	118-119
Injection Pump Assembly	120-121
Injection Pump Components Assembly	122-123
Speed Control Plate Assembly.....	124-125
Nozzle Holder And Glow Assembly.....	126-127
Nozzle Holder Assembly	128-129
Fork Lever Assembly	130-131
Fuel Filter Assembly	132-133
Fuel Pump Assembly	134-135
Dynamo and Pulley Assembly	136-137
Dynamo Assembly	138-139
Starter Assembly	140-141
Starter Components Assembly	142-143
Oil Switch Assembly	144-145
Water Flange and Thermostat Assembly	146-147
Water Pump Assembly	148-149
Water Pipe Assembly	150-151
Fan Assembly	152-153
Valve and Rocker Arm Assembly	154-155
Inlet Manifold Assembly	156-157
Exhaust Manifold Assembly	158-159
Glow Plug/Lamp and Timer Assembly	160-161
Starter Switch Assembly	162-163
Air Cleaner Assembly	164-165
Accessories	166-167
Piston Kit (Option)	168-169
Terms and Conditions Of Sale — Parts.....	170

NOTICE

Specifications and part numbers are subject to change without notice.

PARTS ORDERING PROCEDURES

Ordering parts has never been easier! Choose from three easy options:

Effective:
January 1st, 2006

www.multiquip.com



Order via Internet (Dealers Only):

Order parts on-line using Multiquip's SmartEquip website!

- View Parts Diagrams
- Order Parts
- Print Specification Information



If you have an MQ Account, to obtain a Username and Password, E-mail us at: parts@multiquip.com.

To obtain an MQ Account, contact your District Sales Manager for more information.

Goto www.multiquip.com and click on

Order Parts to log in and save!

Use the **internet** and qualify for a **5% Discount** on *Standard orders* for all orders which include complete part numbers.*

Note: Discounts Are Subject To Change

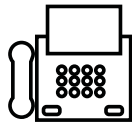

Order via Fax (Dealers Only):

All customers are welcome to order parts via Fax.

Domestic (US) Customers dial:
1-800-6-PARTS-7 (800-672-7877)

Fax your order in and qualify for a **2% Discount** on *Standard orders* for all orders which include complete part numbers.*

Note: Discounts Are Subject To Change



Order via Phone: Domestic (US) Dealers Call:
1-800-427-1244

Non-Dealer Customers:

Contact your local Multiquip Dealer for parts or call 800-427-1244 for help in locating a dealer near you.



International Customers should contact their local Multiquip Representatives for Parts Ordering information.

When ordering parts, please supply:

- | | |
|-------------------------------------------------------------------------------|----------------------------------------------------------------------------------------|
| <input type="checkbox"/> Dealer Account Number | <input type="checkbox"/> Specify Preferred Method of Shipment: |
| <input type="checkbox"/> Dealer Name and Address | <input checked="" type="checkbox"/> UPS/Fed Ex <input checked="" type="checkbox"/> DHL |
| <input type="checkbox"/> Shipping Address (if different than billing address) | <input type="checkbox"/> Priority One <input checked="" type="checkbox"/> Truck |
| <input type="checkbox"/> Return Fax Number | <input type="checkbox"/> Ground |
| <input type="checkbox"/> Applicable Model Number | <input type="checkbox"/> Next Day |
| <input type="checkbox"/> Quantity, Part Number and Description of Each Part | <input type="checkbox"/> Second/Third Day |

NOTICE

All orders are treated as *Standard Orders* and will ship the same day if received prior to 3PM PST.

WE ACCEPT ALL MAJOR CREDIT CARDS!



SAFETY INFORMATION

Do not operate or service the equipment before reading the entire manual. Safety precautions should be followed at all times when operating this equipment. Failure to read and understand the safety messages and operating instructions could result in injury to yourself and others.

SAFETY MESSAGES

The four safety messages shown below will inform you about potential hazards that could injure you or others. The safety messages specifically address the level of exposure to the operator and are preceded by one of four words: **DANGER**, **WARNING**, **CAUTION** or **NOTICE**.

SAFETY SYMBOLS

! DANGER

Indicates a hazardous situation which, if not avoided, **WILL** result in **DEATH** or **SERIOUS INJURY**.

! WARNING

Indicates a hazardous situation which, if not avoided, **COULD** result in **DEATH** or **SERIOUS INJURY**.







! CAUTION

Indicates a hazardous situation which, if not avoided, **COULD** result in **MINOR** or **MODERATE INJURY**.

NOTICE

Addresses practices not related to personal injury.

Potential hazards associated with the operation of this equipment will be referenced with hazard symbols which may appear throughout this manual in conjunction with safety messages.

Symbol	Safety Hazard
	Lethal exhaust gas hazards
	Explosive fuel hazards
	Burn hazards
	Overspeed hazards
	Rotating parts hazards
	Pressurized fluid hazards
	Electric shock hazards

SAFETY INFORMATION

GENERAL SAFETY

CAUTION

- **NEVER** operate this equipment without proper protective clothing, shatterproof glasses, respiratory protection, hearing protection, steel-toed boots and other protective devices required by the job or city and state regulations.



- **NEVER** operate this equipment when not feeling well due to fatigue, illness or when under medication. 
- **NEVER** operate this equipment under the influence of drugs or alcohol.



- **ALWAYS** check the equipment for loosened threads or bolts before starting.
- **DO NOT** use the equipment for any purpose other than its intended purposes or applications.

NOTICE

- This equipment should only be operated by trained and qualified personnel 18 years of age and older.
- Whenever necessary, replace nameplate, operation and safety decals when they become difficult read.
- Manufacturer does not assume responsibility for any accident due to equipment modifications. Unauthorized equipment modification will void all warranties.

- **NEVER** use accessories or attachments that are not recommended by MQ Power for this equipment. Damage to the equipment and/or injury to user may result.

- **ALWAYS** know the location of the nearest **fire extinguisher**.



- **ALWAYS** know the location of the nearest **first aid kit**.



- **ALWAYS** know the location of the nearest phone or **keep a phone on the job site**. Also, know the phone numbers of the nearest **ambulance, doctor and fire department**. This information will be invaluable in the case of an emergency.



GENERATOR SAFETY

DANGER

- **NEVER** operate the equipment in an explosive atmosphere or near combustible materials. An explosion or fire could result causing severe **bodily harm or even death**.



WARNING

- **NEVER** disconnect any **emergency or safety devices**. These devices are intended for operator safety. Disconnection of these devices can cause severe injury, bodily harm or even death. Disconnection of any of these devices will void all warranties.

CAUTION

- **NEVER** lubricate components or attempt service on a running machine.

NOTICE

- **ALWAYS** ensure generator is on level ground before use.
- **ALWAYS** keep the machine in proper running condition.
- Fix damage to machine and replace any broken parts immediately.
- **ALWAYS** store equipment properly when it is not being used. Equipment should be stored in a clean, dry location out of the reach of children and unauthorized personnel

SAFETY INFORMATION

ENGINE SAFETY

DANGER

- The engine fuel exhaust gases contain poisonous carbon monoxide. This gas is colorless and odorless, and can cause death if inhaled.
- The engine of this equipment requires an adequate free flow of cooling air. **NEVER** operate this equipment in any enclosed or narrow area where free flow of the air is restricted. If the air flow is restricted it will cause injury to people and property and serious damage to the equipment or engine.



WARNING

- **DO NOT** place hands or fingers inside engine compartment when engine is running.
- **NEVER** operate the engine with heat shields or guards removed.
- Keep fingers, hands hair and clothing away from all moving parts to prevent injury.
- **DO NOT** remove the radiator cap while the engine is hot. High pressure boiling water will gush out of the radiator and severely scald any persons in the general area of the generator.
- **DO NOT** remove the coolant drain plug while the engine is hot. Hot coolant will gush out of the coolant tank and severely scald any persons in the general area of the generator.



CAUTION

- **NEVER** touch the hot exhaust manifold, muffler or cylinder. Allow these parts to cool before servicing equipment.



NOTICE

- **NEVER** run engine without an air filter or with a dirty air filter. Severe engine damage may occur. Service air filter frequently to prevent engine malfunction.
- **NEVER** tamper with the factory settings of the engine or engine governor. Damage to the engine or equipment can result if operating in speed ranges above the maximum allowable.
- Wet stacking is a common problem with diesel engines which are operated for extended periods with light or no load applied. When a diesel engine operates without sufficient load (less than 40% of the rated output), it will not operate at its optimum temperature. This will allow unburned fuel to accumulate in the exhaust system, which can foul the fuel injectors, engine valves and exhaust system, including turbochargers, and reduce the operating performance.



In order for a diesel engine to operate at peak efficiency, it must be able to provide fuel and air in the proper ratio and at a high enough engine temperature for the engine to completely burn all of the fuel.

Wet stacking does not usually cause any permanent damage and can be alleviated if additional load is applied to relieve the condition. It can reduce the system performance and increase maintenance. Applying an increasing load over a period of time until the excess fuel is burned off and the system capacity is reached usually can repair the condition. This can take several hours to burn off the accumulated unburned fuel.

- State Health Safety Codes and Public Resources Codes specify that in certain locations, spark arresters must be used on internal combustion engines that use hydrocarbon fuels. A spark arrester is a device designed to prevent accidental discharge of sparks or flames from the engine exhaust. Spark arresters are qualified and rated by the United States Forest Service for this purpose. In order to comply with local laws regarding spark arresters, consult the engine distributor or the local Health and Safety Administrator.

SAFETY INFORMATION

FUEL SAFETY

DANGER

- **DO NOT** start the engine near spilled fuel or combustible fluids. Diesel fuel is extremely flammable and its vapors can cause an explosion if ignited.
- **ALWAYS** refuel in a well-ventilated area, away from sparks and open flames.
- **ALWAYS** use extreme caution when working with **flammable** liquids.
- **DO NOT** fill the fuel tank while the engine is running or hot.
- **DO NOT** overfill tank, since spilled fuel could ignite if it comes into contact with hot engine parts or sparks from the ignition system.
- Store fuel in appropriate containers, in well-ventilated areas and away from sparks and flames.
- **NEVER** use fuel as a cleaning agent.
- **DO NOT** smoke around or near the equipment. Fire or explosion could result from fuel vapors or if fuel is spilled on a hot engine.



TOWING SAFETY

CAUTION

- Check with your local county or state safety towing regulations, in addition to meeting **Department of Transportation (DOT) Safety Towing Regulations**, before towing your generator.
- Refer to MQ Power trailer manual for additional safety information.
- In order to reduce the possibility of an accident while transporting the generator on public roads, **ALWAYS** make sure the trailer that supports the generator and the towing vehicle are mechanically sound and in good operating condition.
- **ALWAYS** shutdown engine before transporting



- Make sure the hitch and coupling of the towing vehicle are rated equal to, or greater than the trailer “gross vehicle weight rating.”
- **ALWAYS** inspect the hitch and coupling for wear. **NEVER** tow a trailer with defective hitches, couplings, chains, etc.
- Check the tire air pressure on both towing vehicle and trailer. **Trailer tires should be inflated to 50 psi cold.** Also check the tire tread wear on both vehicles.
- **ALWAYS** make sure the trailer is equipped with a **safety chain**.
- **ALWAYS** properly attach trailer’s safety chains to towing vehicle.
- **ALWAYS** make sure the vehicle and trailer directional, backup, brake and trailer lights are connected and working properly.
- DOT Requirements include the following:
 - Connect and test electric brake operation.
 - Secure portable power cables in cable tray with tie wraps.
- The maximum speed for highway towing is **55 MPH** unless posted otherwise. Recommended off-road towing is not to exceed **15 MPH** or less depending on type of terrain.
- Avoid sudden stops and starts. This can cause skidding, or jack-knifing. Smooth, gradual starts and stops will improve towing.
- Avoid sharp turns to prevent rolling.
- Trailer should be adjusted to a level position at all times when towing.
- Raise and lock trailer wheel stand in up position when towing.
- Place **chock blocks** underneath wheel to prevent **rolling** while parked.
- Place **support blocks** underneath the trailer’s bumper to prevent **tipping** while parked.
- Use the trailer’s swivel jack to adjust the trailer height to a level position while parked.

SAFETY INFORMATION

ELECTRICAL SAFETY

DANGER

- **DO NOT** touch output terminals during operation. Contact with output terminals during operation can cause **electrocution, electrical shock or burn.**

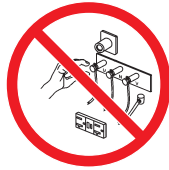

- The electrical voltage required to operate the generator can cause severe injury or even death through physical contact with live circuits. Turn generator and all circuit breakers **OFF** before performing maintenance on the generator or making contact with output terminals.

- **NEVER** insert any objects into the output receptacles during operation. This is extremely dangerous. The possibility exists of **electrical shock, electrocution or death.**



- Backfeed to a utility system can cause **electrocution** and/or property damage. **NEVER** connect the generator to a building's electrical system without a transfer switch or other approved device. All installations should be performed by a **licensed electrician** in accordance with all applicable laws and electrical codes. Failure to do so could result in electrical shock or burn, causing **serious injury or even death.**



Power Cord/Cable Safety

DANGER

- **NEVER** let power cords or cables **lay in water.**
- **NEVER stand in water** while AC power from the generator is being transferred to a load.
- **NEVER** use **damaged** or **worn** cables or cords when connecting equipment to generator. Inspect for cuts in the insulation.
- **NEVER** grab or touch a live power cord or cable with wet hands. The possibility exists of **electrical shock, electrocution or death.**

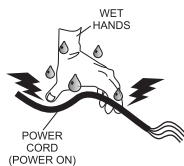

- Make sure power cables are securely connected to the generator's output receptacles. Incorrect connections may cause electrical shock and damage to the generator.

NOTICE

- **ALWAYS** make certain that proper power or extension cord has been selected for the job. See Cable Selection Chart in this manual.

Grounding Safety

DANGER

- **ALWAYS** make sure that electrical circuits are properly grounded to a suitable earth ground (ground rod) per the National Electrical Code (NEC) and local codes before operating generator. **Severe injury or death by electrocution** can result from operating an ungrounded generator.
- **NEVER** use gas piping as an electrical ground.

SAFETY INFORMATION

BATTERY SAFETY

DANGER

- **DO NOT** drop the battery. There is a possibility that the battery will explode.
- **DO NOT** expose the battery to open flames, sparks, cigarettes, etc. The battery contains combustible gases and liquids. If these gases and liquids come into contact with a flame or spark, an explosion could occur.



WARNING

- **ALWAYS** wear safety glasses when handling the battery to avoid eye irritation. The battery contains acids that can cause injury to the eyes and skin.
- Use well-insulated gloves when picking up the battery.
- **ALWAYS** keep the battery charged. If the battery is not charged, combustible gas will build up.
- **ALWAYS** recharge the battery in a well-ventilated environment to avoid the risk of a dangerous concentration of combustible gasses.
- If the battery liquid (dilute sulfuric acid) comes into contact with **clothing or skin**, rinse skin or clothing immediately with plenty of water.
- If the battery liquid (dilute sulfuric acid) comes into contact with **eyes**, rinse eyes immediately with plenty of water and contact the nearest doctor or hospital to seek medical attention.



CAUTION

- **ALWAYS** disconnect the **NEGATIVE** battery terminal before performing service on the generator.
- **ALWAYS** keep battery cables in good working condition. Repair or replace all worn cables.

ENVIRONMENTAL SAFETY

NOTICE

- Dispose of hazardous waste properly. Examples of potentially hazardous waste are used motor oil, fuel and fuel filters.
- **DO NOT** use food or plastic containers to dispose of hazardous waste.
- **DO NOT** pour waste, oil or fuel directly onto the ground, down a drain or into any water source.



SPECIFICATIONS (GENERATOR)

Table 1. Specifications (Generator)		
AC Generator 60 Hz AC Power Source	Model	DA7000SS/DA7000SSA DA7000SSW/DA7000SSWGH
	Type	2-Pole Brushless Revolving Field Type
	Excitation	Solid State, Statically Excited System
	Speed	3,600 RPM
	Cooling System	Self-Ventilation
	Max Power Output	7 kW
	Continuous Power Output	6 kW
	Rated Voltage	120/240V
	Current Max/Continuous (120V)	58.3/50 amps
	Current Max/Continuous (240V)	29.2/25 amps
	Phase	Single Phase (4 wire)
	Frequency	60 Hz
	Power Factor	1
Battery	12V -35Ah	
Dimensions (L x W x H)	25.6 x 44.9 X 31.3 in. (650 X 1,140 X 795 mm)	
Dry Net Weight	526 lbs. (239 kg)	

NOTICE

In keeping with Multiquip's policy of constantly improving its products, the specifications quoted herein are subject to change without prior notice.

SPECIFICATIONS (ENGINE)

Table 2. Specifications (Engine)				
Engine	Kubota Engine Model	Z482-EB	Z482-E2B-DGDE-2	Z482-E3B-DGDE-2
	Tier	1	2	4
	Gen. Enclosure Color	Orange	Orange/White	White
	Type	Vertical, water-cooled, 4-cycle diesel engine		
	Bore X Stroke	2.64 in. X 2.68 in. (67 mm x 68 mm.)		
	Displacement	29.23 cu.-in. (479 cm ³)		
	Number of Cylinders	2		
	Max Output	12.5~13.9 H.P./3600 R.P.M.		
	Fuel	#2 Diesel Fuel		
	Fuel Capacity	6.6 gal. (25 liters)		
	Fuel Consumption	.7 gals. (2.63 liters)/hr.		
	Coolant Capacity	2.95 quarts (2.8 liters)		
	Lube Oil Capacity	2.64 quarts (2.5 liters)		
	Oil Alert System	Yes		
	Starting Method	Electric Start		
Battery	12 Volt @ 35 Ah			
Dimensions (L x W x H)	13.82 x 15.31 X 20.47 in. (351 X 389 X 520 mm)			
Dry Net Weight	117.1 lbs. (53.1 kg)			

Effects of Altitude and Heat

The maximum output of the engines listed above are applicable to supplying electrical power for continuous service at ambient conditions in accordance with SAE Test cord J607. The above ambient conditions are at standard sea level, with a barometric reading of 29.92 inches and a temperature of 60° F (15.5° C).

Generally, the engine's output power will decrease 3-1/2% for each 1000 feet (305 meters) of altitude above sea level, and 1% for each 10° F (-12.2° C) above the standard temperature of 60° F (15.5° C).

DIMENSIONS

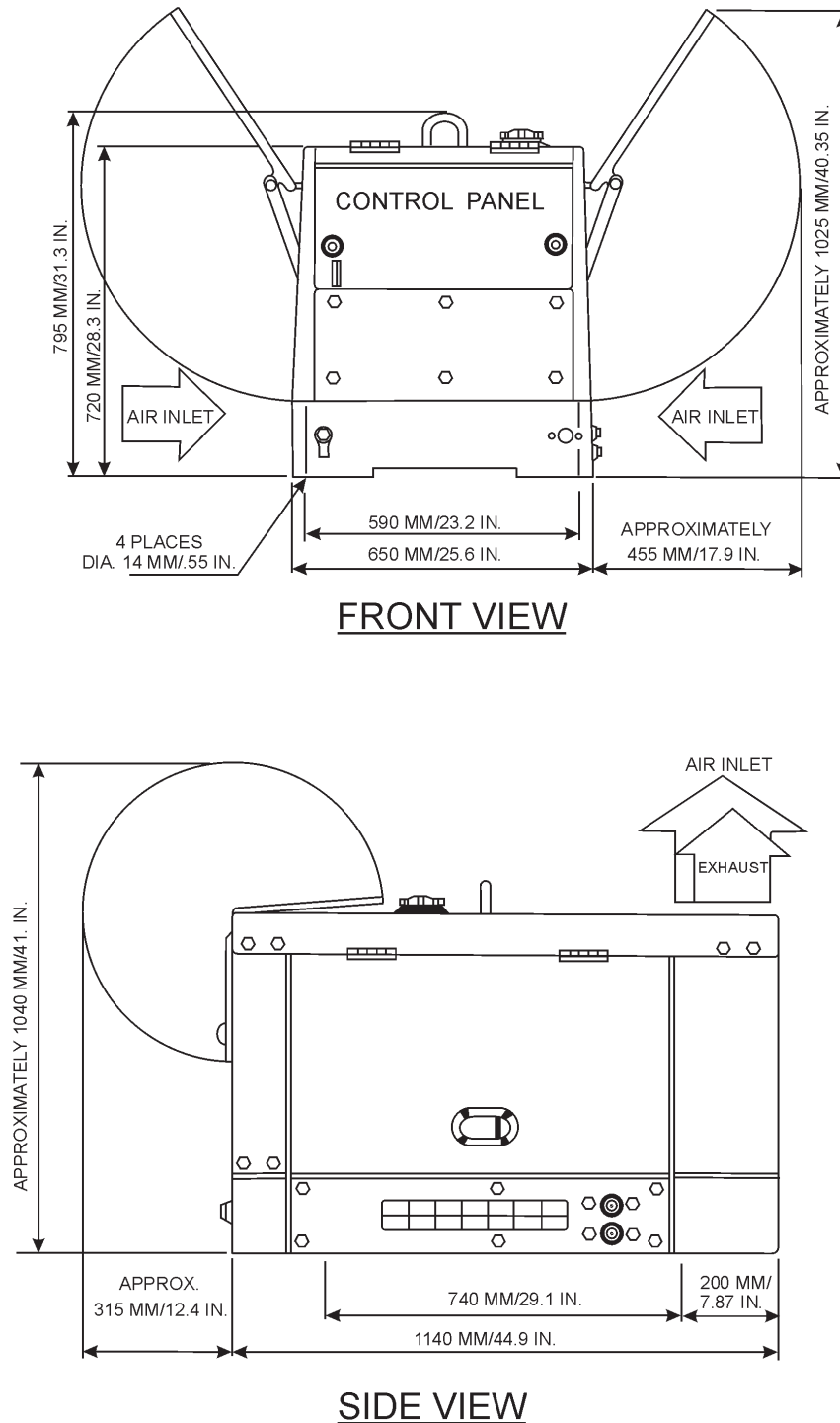

Figure 1. Dimensions

CONNECTING THE GROUND

The nut and ground terminal on the generator should always be used to connect the generator to a suitable ground. The ground cable should be #8 size wire minimum.

At the generator, connect the terminal of the ground cable between the lock washer and the nut (Figure 2) and tighten the nut fully. Connect the other end of the ground cable to a suitable earth ground (ground rod).

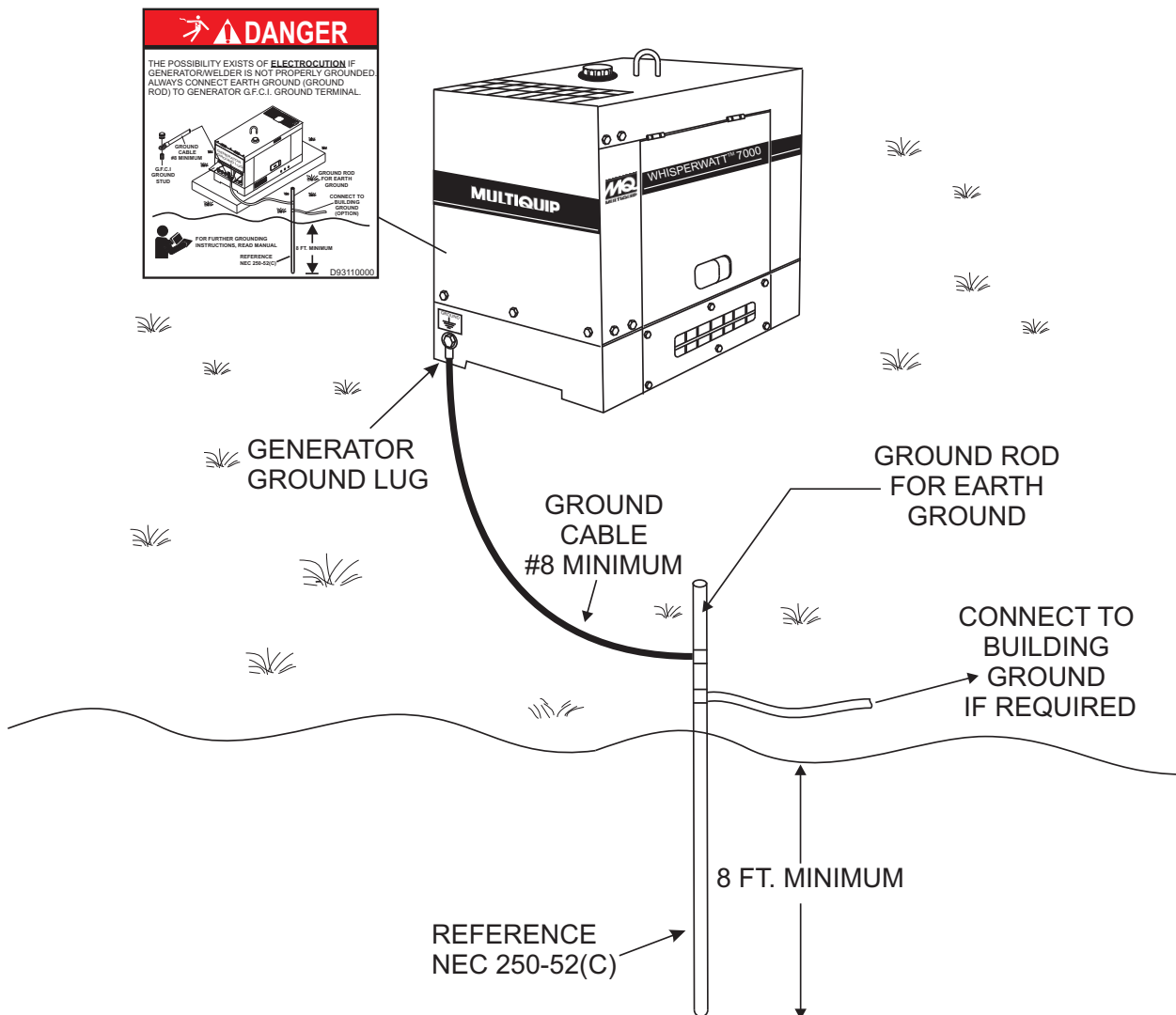



Figure 2. Generator Grounding

OUTDOOR INSTALLATION

If possible install the generator in a area that is free of debris, bystanders, and overhead obstructions. Make sure the generator is on secure level ground so that it cannot slide or shift around.

The installation site must be relatively free from moisture and dust. All electrical equipment should be protected from excessive moisture. Failure to do will result in deterioration of the insulation and will result in short circuits and grounding.

Foreign materials such as dust, sand, lint and abrasive materials have a tendency to cause excessive wear to engine and alternator parts.

 **WARNING**

 Pay close attention to ventilation when operating the generator inside tunnels and caves. The engine exhaust contains noxious elements. Engine exhaust must be routed to a ventilated area

INDOOR INSTALLATION

Exhaust gases from gas engines are extremely poisonous. Whenever an engine is installed indoors the exhaust fumes must be vented to the outside. The engine should be installed at least two feet from any outside wall. Using an exhaust pipe which is too long or too small can cause excessive back pressure which will cause the engine to heat excessively and possibly burn the valves.

PLACEMENT

The generator should always be placed on a flat level surface when it is running. **DO NOT** place the generator on slopes, the possibility exists that the generator could slide.

 **DANGER**

 An electric shock is apt to happen when vibrators are used. Pay close attention to handling when operating vibrators and always use rubber boots and gloves to insulate the body from a short circuit.

GENERATOR GROUNDING

To guard against electrical shock and possible damage to the equipment, it is important to provide a good **EARTH** ground.

Article 250 (Grounding) of the National Electrical Code (NEC) provides guide lines for proper grounding and specifies that the cable ground shall be connected to the grounding system of the building as close to the point of cable entry as practical.

NEC articles 250-64(b) and 250-66 set the following grounding requirements:

1. Use one of the following wire types to connect the generator to earth ground.
 - a. Copper - 8 AWG (5.3 mm²)
 - b. Aluminum - 6 AWG (8.4 mm²)
2. When grounding the generator (Figure 2) connect the ground cable between the lock washer and the nut on the generator and tighten the nut fully. Connect the other end of the ground cable to earth ground.
3. NEC article 250-52(c) specifies that the earth ground rod should be buried a minimum of 8 ft. into the ground.

NOTICE

When connecting the generator to any buildings electrical system **ALWAYS** consult with a licensed electrician.

 **DANGER**

Before connecting this generator to any building's electrical system, a licensed electrician must install an isolation (transfer) switch.

Serious injury or death may result without this transfer switch.

FAMILIARIZATION

Generator

The Multiquip DA7000 Series generators are 6.0 kW (continuous output), 7.0 kW (max output) A.C. generators designed as a portable dual purpose power source for 60 Hz (single phase) lighting facilities, power tools, submersible pumps and other industrial and construction machinery.

Control Panel

The control box is provided with the following:

- GFCI 120 volt receptacle, 20 amp (single-phase)
- 120 volt receptacle, 25 amp (single-phase)
- 120/240 volt receptacle, 25 amp (single-phase)
- 120/240 volt receptacle, 25 amp (single-phase)
- AC Voltmeter
- Main Circuit Breaker 265V @25 Amps
- GFCI Circuit Breaker 120V @20 Amps
- Idle Control Switch
- Starter Switch
- Warning Lamp Unit
- Hour Meter
- Ground Terminal

Engine Protection System

Engine protection fail safe features are provided in the event of low oil pressure, high coolant temperature and failure of the battery to charge. If any of the above conditions occur while operating the generator it will cause a complete unit shut down.

Battery Charge Alarm

This unit is equipped with a protective device that signals an alarm and automatically stops the engine when the battery cannot be charged by the alternator.

Water Temperature Alarm

This unit is equipped with an apparatus that signals an alarm and automatically stops the engine when the cooling water temperature becomes abnormally high. This apparatus will not function properly if the machine is operated with less than the proper amount of coolant.

Oil Pressure Warning Alarm

This unit is equipped with a protective device that detects low oil pressure. If the lubricating oil pressure of this unit should become abnormally low, the protective device will automatically stop the engine. If this condition should occur, please refer to the engine troubleshooting table in this manual.

Idle Control Switch

The DA7000 series generators are provided with an automatic idle (engine) control capability for noise suppression and fuel cost reduction. The automatic idle control feature automatically engages under a no-load condition.

With AC loads of more than 150W (such as lighting equipment, motor-powered tools, submersible water pumps, etc.), the engine runs at high speed. When a no load condition is produced, the engine automatically slows down.

Turn the idle control switch to the "ON" (up) position when AC loads of more than 150W are connected. Turn the idle control switch to the "OFF" (down) position when AC loads of less than 100W or when a magnetic switch is used.

Excitation System

The DA7000 series generators use a brushless exciter to create rated output electricity. This system will use the mechanical energy generated by the 3600 RPM engine to spin the rotor (or armature) inside the generator (or alternator end).

Excitation current is sourced from the battery to the excitation winding in the stator. Current applied to this coil creates a magnetic field. The rotating armature is induced with AC current.

Engine

The DA7000 series generators are powered by a water-cooled, 4-cycle KUBOTA diesel engine. This engine is designed to meet every performance requirement of the generator. Reference Table 2, engine specifications.

In keeping with Multiquip's policy of constantly improving its products, the specifications quoted herein are subject to change without prior notice.

Figure 3 and Figure 4 show the basic controls and indicators for the DA7000 series generators.

COMPONENTS (GENERATOR)

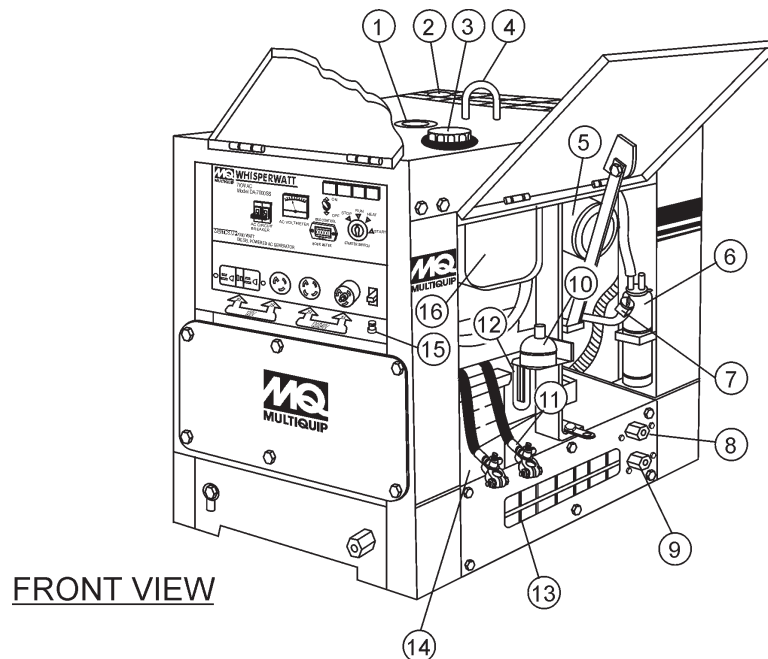

Figure 3. Generator Components

1. **Fuel Gauge** — Indicates the amount of fuel in the fuel tank.
2. **Air Outlet Exhaust** — Allows engine exhaust to exit the generator into the open air. **NEVER** block this opening.
3. **Fuel Cap** — Remove this cap to add fuel. Add only #2 Diesel Fuel. Always keep an adequate amount of fuel in the tank. **DO NOT** top off. Wipe up any spilled fuel immediately.
4. **Lifting Hook** — Use this hook to lift the generator.
5. **Engine Air Cleaner** — Prevents dirt and other debris from entering the fuel system. Lift locking latch on air filter cannister to gain access to filter element.
6. **Overflow Bottle** — Supplies coolant to the radiator when radiator coolant level is low. Fill to indicated level as shown on bottle.
7. **Engine Oil Filler Port** — Remove this cap to add engine oil. Use only recommended type oil. See Table 5.
8. **Coolant Drain Plug** — Remove this plug to drain coolant from the radiator.
9. **Oil Drain Plug** — Remove this plug to drain oil from the engine.
10. **Automatic Speed Control Solenoid** — Automatically regulates engine speed.
11. **Battery Terminals** — Connect these terminals to the battery. Always pay close attention to the polarity of the terminals when connecting to the battery, **RED** (positive), and **BLACK** (negative).
12. **Fuel Filter** — Prevents dirt and other debris from entering the fuel system. Change fuel filter as recommended in the maintenance section of this manual.
13. **Air Inlet Vent** — Allows outside air to enter the generator. **NEVER** block this opening.
14. **Battery** — Provides +12 VDC power for the generator. When replacing battery (12V 35 AH) use only recommended type battery.
15. **Ground Terminal** — Use this terminal to connect external equipment grounds so that the GFCI receptacle will have a ground path.
16. **Fuel Tank** — Holds 6.6 gallons (25 liters) of diesel fuel.

COMPONENTS (GENERATOR)

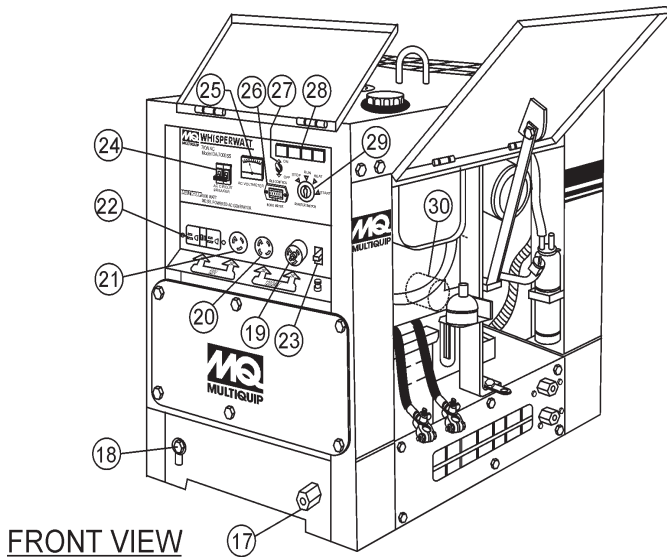

Figure 4. Generator Components

17. **Fuel drain Plug** — Remove this plug to drain fuel from the fuel tank.
18. **Frame Ground Lug** — Connect a ground strap between this lug and a ground rod. Make sure that the ground rod is inserted deep into the ground to provide a good earth ground. Consult with local Electrical and Safety Codes for proper connection.
19. **CS6369 Receptacle** — Dual voltage receptacle, provides 120/240 volts output at 25 amps.
20. **L-14-30R Receptacle** — Dual voltage receptacle, provides 120/240 volts output at 25 amps.
21. **L5-30R Receptacle** — Provides 120 volts output at 25 amps.
22. **Receptacle G.F.C.I.** — This receptacle provides 120 volts output at 20 amps.
23. **GFCI Circuit Breaker** — This single pole circuit breaker provides circuit protection (120V @20 amps) for the G.F.C.I. receptacle.
24. **Main Circuit Breaker** — This 2-pole circuit breaker provides circuit protection (265V @25 amps) for the Electric Parts Assembly.
25. **AC Voltmeter** — This voltmeter indicates (with a mark) the rated 60 Hz (single-phase) output voltage. In addition the voltmeter can also be used as a diagnostic tool. If the voltmeter indicator (needle) is

below the rated voltage, engine problems may exist (low/high RPM's). To prevent damage to the generator or power tools turn the generator OFF and consult your authorized Multiquip service dealer.

26. **Hour Meter** — Indicates number of hours machine has been in use or hours engine was run.
27. **Idle Control Switch** — The generator is provided with an automatic idle control device for noise suppression and reduced fuel consumption.

The automatic idle control automatically engages under a no-load condition. With the automatic idle control switched "ON", the engine revolutions will automatically drop to about 2200 rpm (low-speed operation) within 3 seconds after the load stops. When the operation is resumed, the engine speed is automatically increased to about 3600 rpm (high-speed operation) as soon as the load is connected.

28. **Warning Lamp Display** — Lights red when the following conditions occur:
 - **Oil Pressure Lamp** — If the oil pressure drops suddenly, the oil pressure lamp will go on, and the generator will shut down.
 - **Charge Lamp** — The charge lamp will go on when the battery fails to charge, and the generator will shut down.
 - **Water Temperature Lamp** — The water temperature lamp will go on if the temperature rises to an abnormally high level, and the generator will shut down.
29. **Starter Switch** — With key inserted turn clockwise to start engine.
30. **Oil Filter** — Provides oil filtering for the engine.

NOTICE

This **KUBOTA** engine is equipped with a low oil shutdown capability. A built in sensor will automatically turn off the engine should the oil level fall below a safe operating condition. Make sure the generator is placed on level ground. Placing the generator on level ground will ensure that the low oil sensor will function properly.

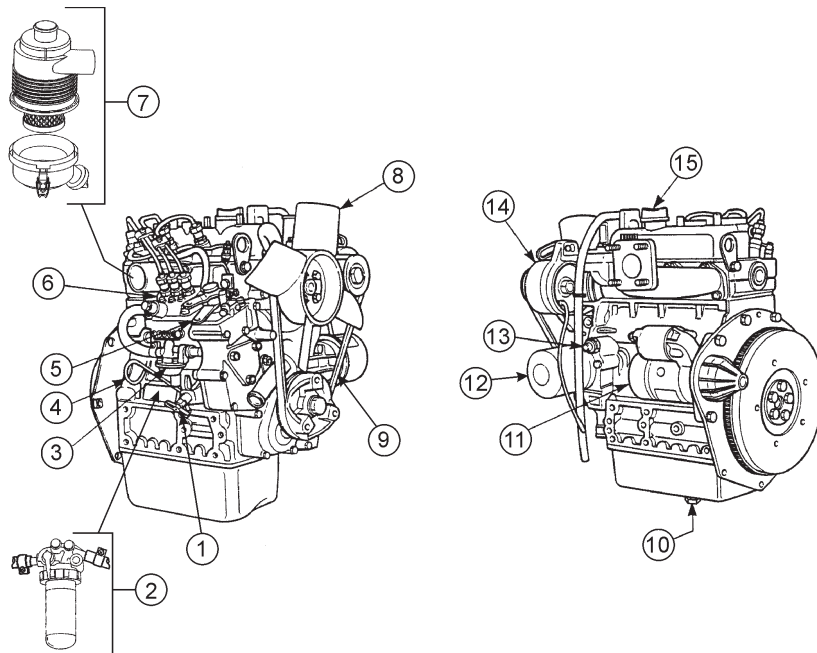

Figure 5. Kubota Z482 Series

INITIAL SERVICING

The engine (Figure 5) must be checked for proper lubrication and filled with fuel prior to operation. Refer to the manufacturer's engine manual for instructions and details of operation and servicing.

1. **Water Drain Cock** — Open this cock to drain water
2. **Fuel Filter** — Prevents dirt and other debris from entering the fuel system. Replace filter as recommended in the maintenance section of this manual.
3. **Fuel Feed Pump** — Pumps fuel to the injection system.
4. **Oil Dip Stick/Gauge** — Remove to check amount and condition of oil in crankcase. Refill or replace with recommended type oil as listed in Table 5.
5. **Speed Control Lever** — Controls engine speed. This lever is factory set. **DO NOT** adjust this lever.
6. **Injector Pump** — Provides fuel under pressure to the injector nozzles.
7. **Air Filter** — Prevents dirt and other debris from entering the fuel system. Loosen clips on side of air filter canister to gain access to filter element. Replace with only manufacturer's recommended type air cleaner.
8. **Cooling Fan Blades** — Make sure cooling fan blades are not bent or broken. A damaged fan blade can cause the engine to run hot and overheat.
9. **Fan V-Belt** — **ALWAYS** make sure V-belt is properly tensioned. A loose or defective V-belt can adversely affect the performance of the generator.
10. **Oil Drain Plug/Crankcase** — Remove to drain crankcase oil. Fill with recommended type oil as listed in Table 5. Crankcase holds a maximum of 2.64 quarts (2.5 liters) of motor oil.
11. **Starter** — Starts engine when ignition key is rotated to the "ON" position
12. **Oil Filter** — Spin-on type, filters oil contaminants. Replace filter as recommended in the maintenance section of this manual.
13. **Oil Pressure Switch** — Monitors engine oil pressure. In the event of low oil pressure engine will shutdown.
14. **Alternator** — Provides power to the +12VDC electrical system. Replace with only manufacturer's recommended type alternator.
15. **Oil Filler Cap** — Fill with recommended type oil as listed in Table 5.

LOAD APPLICATIONS

Single Phase Load — 60 Hz

Always be sure to check the nameplate on the generators and equipment to insure the wattage, amperage and frequency requirements are satisfactorily supplied by the generators for operating the equipment.

Generally, the wattage listed on the nameplate of the equipment is its rated output. Equipment may require 130—150% more wattage than the rating on the nameplate, as the wattage is influenced by the efficiency, power factor and starting system of the equipment.

NOTICE

If wattage is not given on the equipment's name plate, approximate wattage may be determined by multiplying nameplate voltage by the nameplate amperage

$$\text{WATTS} = \text{VOLTAGE} \times \text{AMPERAGE}$$

The power factor of this generators is 1.0 See Table 3 below when connecting loads.

Table 3. Power Factor By Load

Type Of Load	Power Factor
Single-phase induction motors	0.4 - 0.75
Electric heaters, incandescent lamps	1.0
Fluorescent lamps, mercury lamps	0.4 - 0.9
Electronic devices, communication equipment	1.0
Common power tools	0.8

NOTICE

When using a combination of dual receptacles, total load should not exceed the rated capacity of the generator.

NOTICE

When connecting power tools or equipment pay close attention to the required starting current capacity.

To determine the running wattage for your load, multiply the running wattage as indicated by steps 1, 2, and 3 below:

1. INCANDESCENT LOADS

Lights, heaters and similar appliances.
Total the running wattage and multiply by 1.

Example:

29 light bulbs @ 100W each = 2.9 kW
use a 3 kW generator.

2. SMALL MOTORS

Drills and other small power tools.
Total the running wattage and multiply by 2.

Example:

A 1 inch drill runs at 1 kW
use a 2 kW generator

3. LARGE MOTORS

Submersible pumps, table saws etc.
Total the running wattage and multiply by 3.

Example:

A conveyor belt runs at 8 kW
use a 24 kW generator.

NOTICE

Motors and motor-driven equipment draw much greater current for starting than during operation. Always use an adequate size extension cable which can carry the required load.

Extension Cables

When electric power is to be provided to various tools or loads at some distance from the generator, extension cords are normally used. **Cables should be sized to allow for distance in length and amperage so that the voltage drop between the generators and point of use (load) is held to a minimum.** Use the cable selection chart (Table 4) as a guide for selecting proper cable size.

NOTICE

The idle control device is operated at a minimum load capacity of 100W. If the load capacity is less than 100W, place the idle control switch in the **OFF** position.

GENERAL INSPECTION PRIOR TO OPERATION

Ground Power Tools

When using power tools or electrical equipment requiring AC power from the generator, make sure power tool cord has a ground pin or is double insulated as shown in Figure 6.

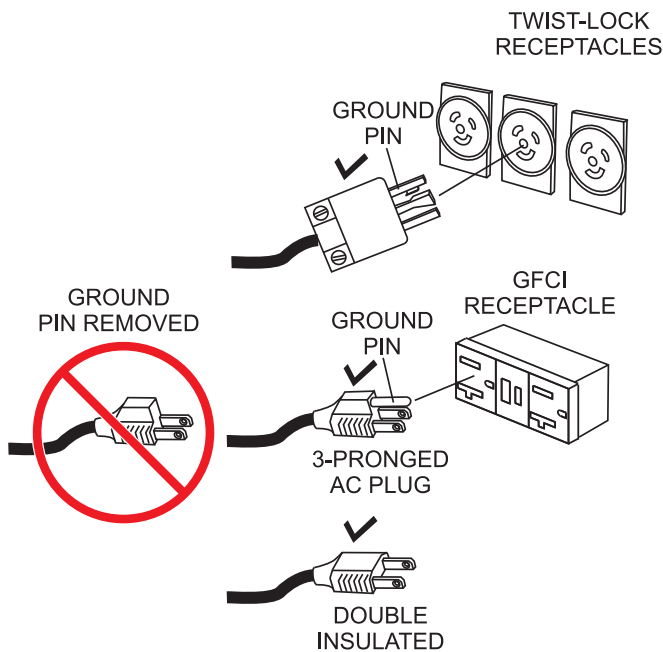

Figure 6. Ground Pin

NOTICE

Double-insulated power tools and small appliances have specially insulated housings that eliminate the need for a ground. These types of double-insulated power cords are designed so that no part of the device will be electrically live even if the internal insulation fails.

Extension Cable

When electric power is to be provided to various tools or loads at some distance from the generator, extension cords are normally used. Cables should be sized to allow for distance in length and amperage so that the voltage drop between the generator and point of use (load) is held to a minimum. Use the cable selection chart (Table 4) as a guide for selecting proper cable size.

! DANGER

NEVER use power tools or equipment that do not have a ground capability, the possibility exists of electrocution, electrical shock or burn, which can cause severe bodily harm or even **DEATH!**

Circuit Breakers

ALWAYS place the *main*, and *GFCI* circuit breakers in the **OFF** position prior to starting the engine.

Table 4. Cable Selection (60 Hz, Single Phase Operation)

Current In Amperes	Load In Watts		Maximum Allowable Cable Length			
	120 Volts	240 Volts	#10 Wire	#12 Wire	#14 Wire	#16 Wire
2.5	300	600	1000 ft.	600 ft.	375 ft.	250 ft.
5	600	1200	500 ft.	300 ft.	200 ft.	125 ft.
7.5	900	1800	350 ft.	200 ft.	125 ft.	100 ft.
10	1200	2400	250 ft.	150 ft.	100 ft.	
15	1800	3600	150 ft.	100 ft.	65 ft.	
20	2400	4800	125 ft.	75 ft.	50 ft.	

CAUTION: Equipment damage can result from low voltage.

INSPECTION/SETUP

Before Starting

1. Read safety instructions at the beginning of manual.
2. Clean the generator, removing dirt and dust, particularly the engine cooling air inlet.
3. Check the air filter for dirt and dust. If air filter is dirty, replace air filter with a new one as required.
4. Check fastening nuts and bolts for tightness

Engine Oil Check

1. To check the engine oil level, place the generator on secure level ground with the engine stopped.
2. Remove the dipstick from its holder (Figure 7) and wipe clean.

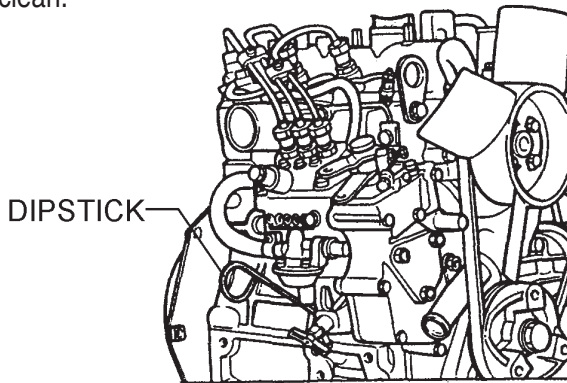

Figure 7. Engine Oil Dipstick Removal

3. Re-Insert dipstick (Figure 8), then remove dipstick from its holder. Check the oil level shown on the dipstick.

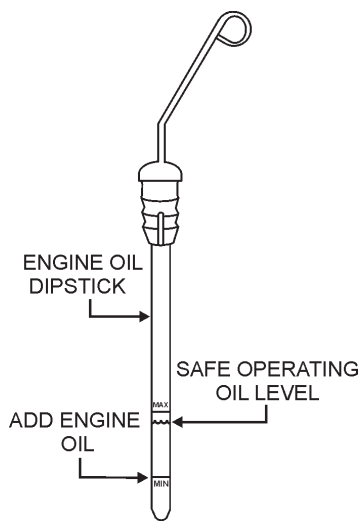

Figure 8. Engine Oil Dipstick

4. If the oil level is low, remove the oil filler cap (Figure 9) and fill to a safe operating level (max) as indicated by the dipstick. Fill with recommended type oil as listed in Table 5. Maximum oil capacity is 2.64 quarts (2.5 liters).

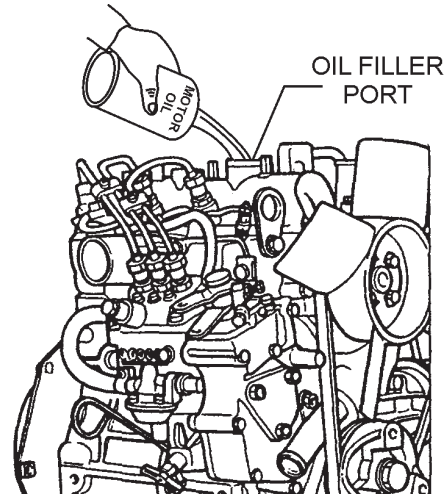

Figure 9. Engine Oil Filler Port

Table 5. Oil Type

Temperature	Oil Type
Above 77° F (25° C)	SAE 30 or SAE10W-30 SAE 15W-40
32° ~ 77° F (0° ~ 25° C)	SAE 20 or SAE10W-30 SAE 15W-40
Below 32° F (0° C)	SAE 10 or SAE10W-30 SAE 15W-40

NOTICE

When adding engine oil **DO NOT** overfill.

Fuel Check

Fill the fuel tank with #2 diesel fuel. **DO NOT** fill the tank beyond capacity.

Pay attention to the fuel tank capacity when replenishing fuel. Refer to the fuel tank capacity listed in Table 2.

The fuel tank cap must be closed tightly after filling. Handle fuel in a safety container. If the container does not have a spout, use a funnel.

1. Read the fuel gauge located on top of the generator (Figure 10) to determine if the fuel level is low.

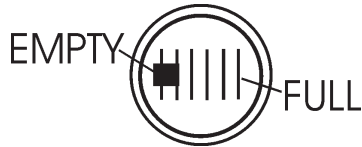

Figure 10. Fuel Gauge

2. If fuel is low, remove the fuel cap (Figure 11) located on top of the generator and replenish with clean #2 diesel fuel.

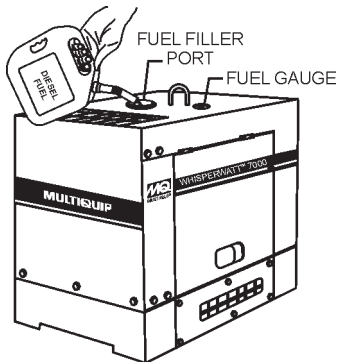

Figure 11. Adding Fuel

DANGER



Motor fuels are highly flammable and can be dangerous if mishandled. **DO NOT** smoke while refueling. **DO NOT** attempt to refuel the generator if the engine is hot!, running or in the dark.

NOTICE

When refueling, be sure to use a strainer for filtration. **DO NOT** top-off fuel. **DO NOT** fill the tank beyond capacity. Wipe up any spilled fuel immediately!

Coolant (Antifreeze)

Kubota recommends Antifreeze/Summer Coolant for use in their engines, which can be purchased in concentrate (and mixed with 50% demineralized water) or pre-diluted. See the Kubota Engine Owner's Manual for further details.

WARNING



If adding coolant/antifreeze mix to the radiator, **DO NOT** remove the radiator cap until the unit has completely cooled. The possibility of hot! coolant exists which can cause severe burns.

Day-to-day addition of coolant is done from the recovery tank. When adding coolant to the radiator, **DO NOT** remove the radiator cap until the unit has completely cooled. See Table 6 for engine, radiator, and recovery tank coolant capacities. Make sure the coolant level in the recovery tank is always between the "H" and the "L" markings.

Table 6. Coolant Capacity

Engine and Radiator	.74 gal (2.8 liters)
Reserve Tank (Full)	.23 gal (.87 liters)

Operation Freezing Weather

When operating in freezing weather, be certain the proper amount of antifreeze (Table 7) has been added.

Table 7. Anti-Freeze Operating Temperatures

Vol % Anti-Freeze	Freezing Point	
	°C	°F
50	-37	-34

NOTICE

When the antifreeze is mixed with water, the antifreeze mixing ratio must be less than 50%.

CLEANING THE RADIATOR

The engine may overheat if the radiator fins become overloaded with dust or debris. Periodically clean the radiator fins with compressed air. Cleaning inside the machine is dangerous, so clean only with the engine turned off and the **negative** battery terminal disconnected.

AIR CLEANER

Periodic cleaning/replacement is necessary. Inspect it in accordance with the KUBOTA Engine Owner's Manual.

Fan Belt Tension

A slack fan belt may contribute to overheating, or to insufficient charging of the battery. Inspect the fan belt for damage and wear and adjust it in accordance with the Kubota Engine Owner's Manual.

The fan belt tension is proper if the fan belt bends 10 to 15 mm (Figure 12) when depressed with the thumb as shown below.

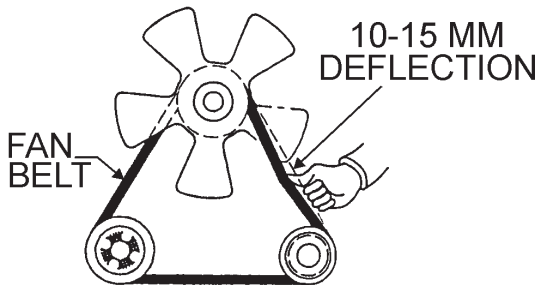

Figure 12. Fan Belt Tension

CAUTION



NEVER place hands near the belts or fan while the generator set is running.

BATTERY

This unit is of negative ground **DO NOT** connect in reverse. Always maintain battery fluid level between the specified marks. Battery life will be shortened, if the fluid level are not properly maintained. Add only distilled water when replenishment is necessary.

DO NOT over fill. Check to see whether the battery cables are loose. Poor contact may result in poor starting or malfunctions. **Always** keep the terminals firmly tightened. Coating the terminals with an approved battery terminal treatment compound. Replace battery with only recommended type battery.

The battery is sufficiently charged if the specific gravity of the battery fluid is 1.28 (at 68° F). If the specific gravity should fall to 1.245 or lower, it indicates that the battery is dead and needs to be recharged or replaced.

Before charging the battery with an external electric source, be sure to disconnect the battery cables.

Battery Cable Installation

ALWAYS be sure the battery cables (Figure 13) are properly connected to the battery terminals as shown below. The **red cable** is connected to the positive terminal of the battery, and the **black cable** is connected to the negative terminal of the battery.

CAUTION

ALWAYS disconnect the negative terminal **FIRST** and reconnect negative terminal **LAST**.

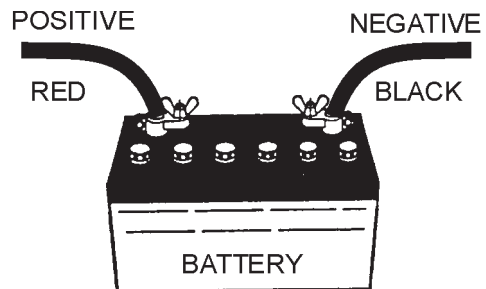

Figure 13. Battery Connections

When connecting battery do the following:

1. **NEVER** connect the battery cables to the battery terminals when the **Ignition Switch** is in the **START** position. **ALWAYS** make sure that the **Ignition Switch** is in the **OFF** position when connecting the battery.
2. Place a small amount of battery terminal treatment compound around both battery terminals. This will ensure a good connection and will help prevent corrosion around the battery terminals.

NOTICE

If the battery cable is connected incorrectly, electrical damage to the generator will occur. Pay close attention to the polarity of the battery when connecting the battery.

CAUTION

Inadequate battery connections may cause poor starting of the generator, and create other malfunctions.

ALTERNATOR

The polarity of the alternator is negative grounding type. When an inverted circuit connection takes place, the circuit will be in short circuit instantaneously resulting the alternator failure.

DO NOT put water directly on the alternator. Entry of water into the alternator can cause corrosion and damage the alternator.

WIRING

Inspect the entire generator for bad or worn electrical wiring or connections. If any wiring or connections are exposed (insulation missing) replace wiring immediately.

PIPING AND HOSE CONNECTION

Inspect all piping, oil hose, and fuel hose connections for wear and tightness. Tighten all hose clamps and check hoses for leaks.

If any hose (**fuel or oil**) lines are defective replace them immediately.

OPERATION

Before Starting the Engine

CAUTION

The engine's exhaust contains harmful emissions. **ALWAYS** have adequate ventilation when operating. Direct exhaust away from nearby personnel.

WARNING

NEVER manually start the engine with the main or GFCI circuit breakers in the **ON** (closed) position.

1. Open the cabinet door and turn the fuel cock lever (Figure 14) to the "ON" position.

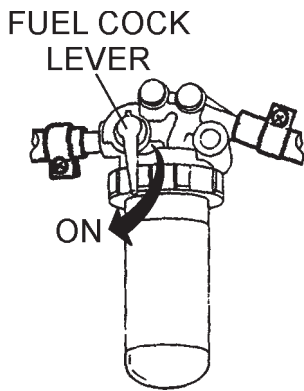

Figure 14. Fuel Cock Lever (ON)

2. **NEVER** operate the generator with the doors *open* (Figure 15). Operation with the doors open may cause insufficient cooling of the unit, and engine damage may result. Close the doors for normal operation.

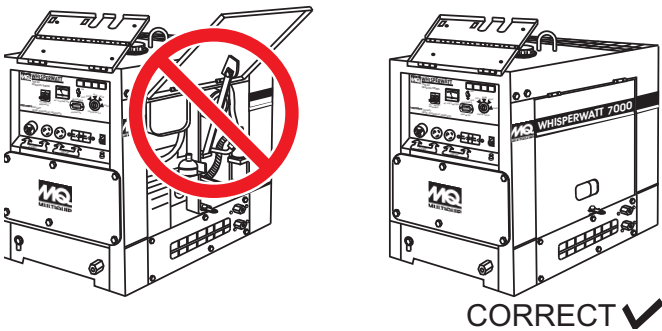

Figure 15. Generator Doors

3. **NEVER** start the engine with the main circuit breaker in the **ON** position. Always place circuit breaker (Figure 16) in the **OFF** position before starting.

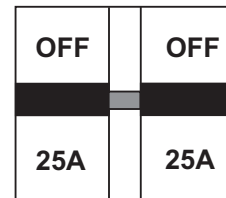

Figure 16. Main Circuit Breaker (OFF)

4. **NEVER** start the engine with the **GFCI** circuit breaker in the **ON** position. Always place circuit breaker (Figure 17) in the **OFF** position before starting the engine.

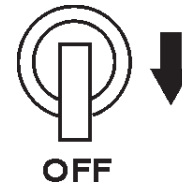

Figure 17. GFCI Circuit Breaker (OFF)

Starting the Engine

1. Insert the key into the starter switch (Figure 18) and turn it to the "RUN" position. Check to see that the oil pressure and charge Lights on the "Warning Lamp Unit Display" are lit. If either light is not lit, check the system and wiring (refer to the Engine Operation Manual).

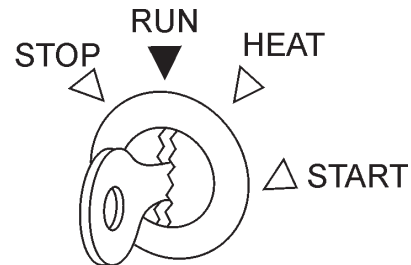

Figure 18. Starter Switch

2. Turn the ignition key to the **HEAT** position. When the preheat light goes off, turn the key to the **START** position to start the engine. As soon as the engine starts, release the key. The key will automatically return to the **RUN** position.
3. During winter or when the surrounding air temperature is cold, in situations where a load start is required, turn the key to the **HEAT** position, you must wait until the preheat light goes off.

- If the engine does not start within 10 seconds after the key is turned to the **START** position, wait for about 30 seconds and repeat the procedure as described in step 4. above.
- When the engine starts, the oil pressure light and charge light should go out. If these lights stay on, immediately stop the engine and check the system and wiring (refer to the Engine Operation Manual).
- Let the engine idle for five minutes with the **Idle Control Switch** (Figure 19) placed in the **ON** position.



Figure 19. Idle Control Switch (ON)

NOTICE

Placing the idle control switch (Figure 19) in the **OFF** position allows the engine to operate at a maximum speed of about 3600 RPM's.

When the idle control switch is placed in the up position (**ON**), the generator will run at idle speed (2200 RPM's) until a load is applied, at that time the engine speed will increase to 3600 RPM's as long as a load is being applied.

When the load is not in use, the engine speed will drop back to the idle mode after about 3 seconds.

Output Voltage Verification

- Place **main** circuit breaker (Figure 20) in the **ON** position.

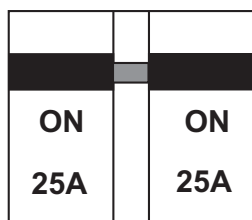

Figure 20. Main Circuit Breaker (ON)

- Place **GFCI** circuit breaker (Figure 21) in the **ON** position.

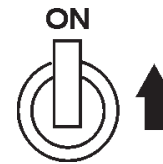

Figure 21. GFCI Circuit Breaker (ON)

- Read voltmeter on front panel of generator (Figure 22) and verify that 120 VAC is displayed. Using an external voltmeter as shown in Figure 22, verify that 120 VAC is present at the 120V twist-lock and GFCI duplex receptacles.

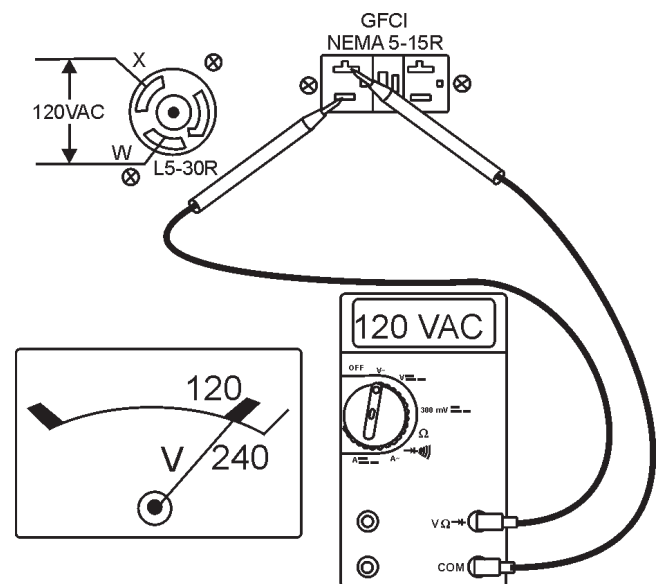

Figure 22. 120V GFCI/L5-30R Receptacles

NOTICE

When using a combination of dual receptacles, total load should not exceed the rated capacity of the generator.

OPERATION/SHUTDOWN

- The CS-6369 receptacle is a dual voltage receptacle (120/240 volts). Using an external voltmeter as shown in Figure 23, verify that 120/240 VAC is present at the CS-6369 twist-lock receptacle.

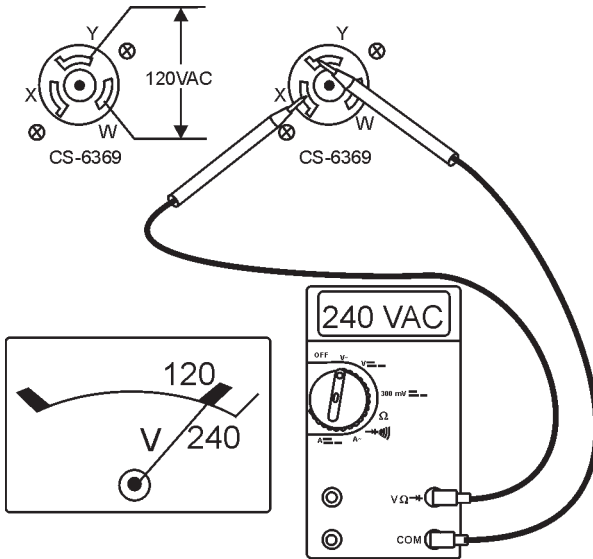

Figure 23. 120/240 CS-6369 Receptacle

- The L14-30R receptacle is a dual voltage receptacle (120/240 volts). Using an external voltmeter as shown in Figure 24, verify that 120/240 VAC is present at the L14-30R twist-lock receptacle.

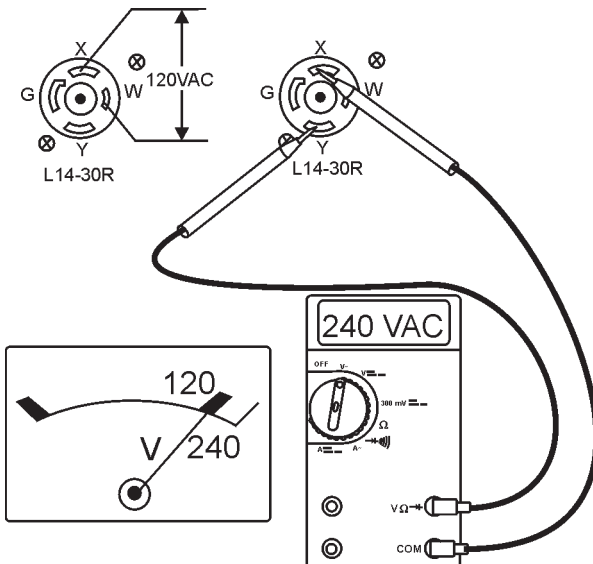

Figure 24. 120/240V L14-30R Receptacle

- Connecting of loads (power tools, lighting ect.) to the generator receptacles can now be done.

Stopping the Engine (Normal Shutdown)

- Place **main** circuit breaker (Figure 25) in the **OFF** position.

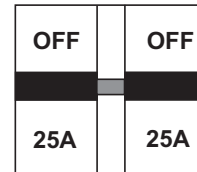

Figure 25. Main Circuit Breaker (OFF)

- Place **GFCI** circuit breakers (Figure 26) in the **OFF** position.



Figure 26. GFCI Circuit Breakers (OFF)

- Place idle control switch (Figure 27) in the **ON** position.



Figure 27. Idle Control switch (OFF)

- Let engine run at idle with no load for 3-5 minutes.
- Place the starter switch key (Figure 28) in the **STOP** position and remove the key. Place fuel cock lever in the **OFF** position.

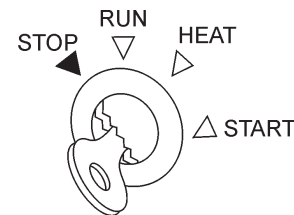

Figure 28. Starter Switch (Stop Position)

- Remove all loads from the generator.

Emergency Shutdown

- Place starter switch key in **STOP** position. Remove key. Place fuel cock lever in the **OFF** position.

PREPARATION FOR LONG TERM STORAGE

Generator Storage

For storage of the generating set for over 30 days, the following is required:

- Run the engine until all the fuel is completely consumed.
- Drain the fuel tank completely, or add STA-BIL to the fuel
- Completely drain the oil from the crankcase and refill with fresh oil.
- Disconnect the ***negative battery cable*** from the battery.
- Clean all external parts of the generating set with a cloth.
- If generator is mounted on a trailer, jack trailer up and place on blocks so tires do not touch the ground or block and completely remove the tires.
- Cover the generating set and store in a clean, dry place.

MAINTENANCE

Use Table 8as a general maintenance guideline when servicing your engine. For more detail engine maintenance information, refer to the engine owner's manual supplied with your engine.

Table 8. Engine Maintenance Schedule

DESCRIPTION (3)	OPERATION	DAILY	FIRST MONTH OR 50 HRS.	EVERY 3 MONTHS OR 25 HRS.	EVERY 6 MONTHS OR 50 HRS.	EVERY YEAR OR 100 HRS.	EVERY 2 YEARS OR 200 HRS.	EVERY 8 YEARS OR 800 HRS.	
Engine Oil	CHECK	X							
	CHANGE		X			X			
Oil Filter Cartridge	CHANGE						X		
Air Cleaner Element	CHECK	X							
	CHANGE				X(1)				
All Nuts & Bolts	RETIGHTEN IF NECESSARY	X							
Cooling Fins	CHECK				X				
Fuel Tank	CLEAN						X		
Fuel Filter	CLEAN					X			
Fuel Filter Element	CHANGE						X		
Fuel lines	CHANGE	Every 2 years, replace if necessary (2)							
Battery	CHANGE						X		
Radiator Hoses/ Clamps	CHANGE	Every 2 years, replace if necessary (2)							
Radiator Coolant	CHANGE						X		
Idle Speed	CHECK-ADJUST					X (2)			
Valve Clearance	CHECK-ADJUST							X (2)	

(1) Service more frequently when used in **DUSTY** areas.

(2) These items should be serviced by your service dealer, unless you have the proper tools and are mechanically proficient. Refer to the KUBOTA Shop Manual for service procedures.

(3) For commercial use, log hours of operation to determine proper maintenance intervals.

NOTICE

Thoroughly remove dirt and oil from the engine and control area. Clean or replace the air cleaner elements as necessary. Check and retighten all fasteners as necessary..

Maintenance

Perform the scheduled maintenance procedures as defined by Table 8 and below:

Engine Oil

Every 100 hours: Change engine oil after the first 50 hours of operation and 100 hours thereafter. Always check the crankcase oil level prior to each use, or when the fuel tank is filled. Insufficient oil may cause severe engine damage. Make sure generator is level when checking oil level. The oil level must be between the two notches on the dipstick as shown in Figure 8.

1. Remove engine oil drain plug located at the bottom of the generator enclosure (Figure 29) and drain oil from crankcase. For best results drain oil while engine is warm. Reinstall oil drain plug, and add engine oil as specified in Table 5. Crankcase oil capacity is 2.64 qts. (2.5 liters).

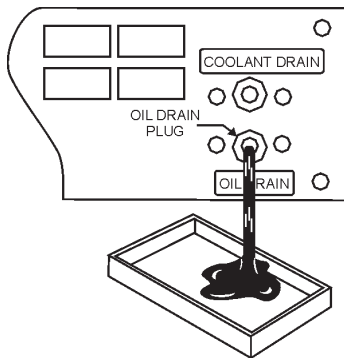

Figure 29. Engine Oil Drain Plug

Oil Filter Cartridge

Every 200 hours: Replace the engine oil filter cartridge after every 200 hours of operation.

1. Clean oil filter mounting base, and coat oil filter seal (Figure 30) with clean engine oil.

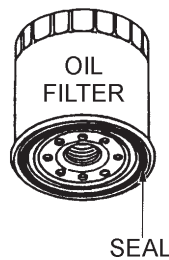

Figure 30. Oil Filter Cartridge

2. Screw on new oil filter by hand until seal contacts the filter mounting base. Install drain bolt with sealing washer and hand tighten.

NOTICE

When installing the oil filter, coat rubber seal with a small amount of lubricant (motor oil). **DO NOT** over-tighten cartridge. Hand tighten only.

3. Replace engine oil with recommended type oil as listed in Table 5. For engine oil capacity, see Table 2 (engine specifications). Fill to upper limit as shown in Figure 8.

Engine Air Cleaner

Every 50 hours: The air cleaner employed on the KUBOTA Z482 series engines is a dry type, **NEVER** apply oil to it. If generator is used in severe dusty areas service air cleaner element more frequently.

1. Release the air cleaner retaining clamps (Figure 31) and remove the air cleaner element.

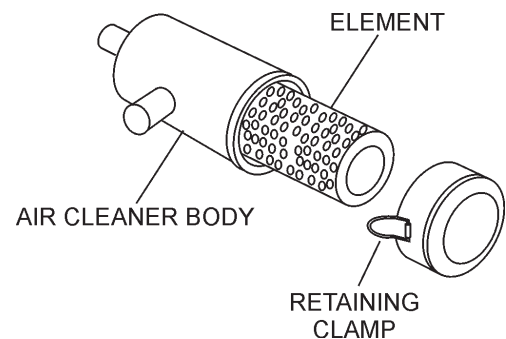

Figure 31. Air Cleaner

2. Wipe the inside of the air cleaner with a clamp cloth and remove all dust and debris that may have accumulated inside air cleaner body.
3. Tap the edge of element lightly to allow heavy dust build-up to fall off.
4. Tap the paper filter element (Figure 31) several times on a hard surface to remove dirt, or blow compressed air [not exceeding 99 psi (686 kPa, 2.1 kgf/cm²)] through the filter element from from the inside while turning the element. **NEVER** brush off dirt. Brushing will force dirt into the fibers.
5. Replace the filter element once a year or every six cleanings or if it is excessively dirty

Cleaning the Fuel Filter

Every 100 hours: Clean fuel filter every 100 hours of operation or once a month to remove dust or water.

1. Place fuel cock lever (Figure 32) in the close position.
2. Disconnect fuel lines from fuel filter.

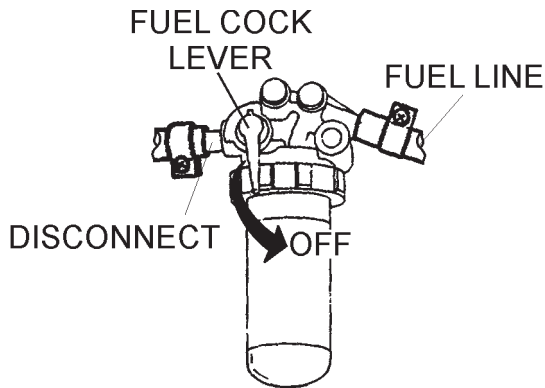

Figure 32. Fuel Cock Lever (OFF)

Replacing Fuel Filter Element

Every 200 hours: Replace fuel filter element.

1. Remove the top cap (Figure 33) from the fuel filter and rinse cap and filter bowl with diesel fuel.
2. Remove element, and rise with diesel fuel.
3. Reinstall fuel filter and connect fuel lines.

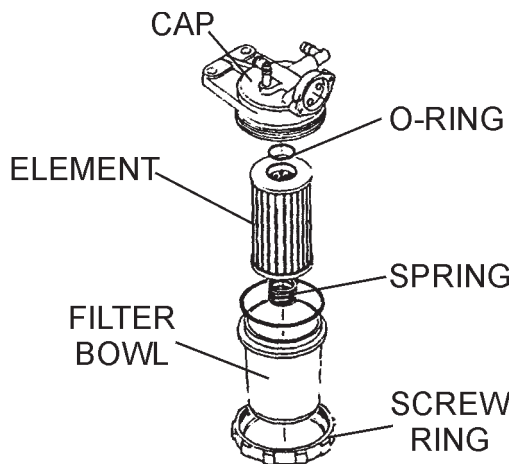

Figure 33. Fuel Filter Disassembly

4. Inspect all fuel lines every 50 hours.

Radiator

Check Daily: Always check the level of the coolant in the radiator before starting the engine. Remove the radiator cap and verify that the coolant reaches top of radiator coils.

1. **DO NOT** remove the radiator cap while the coolant is hot. The possibility exists of severe burns or scalding from the coolant gushing out. Let the coolant cool before removing radiator cap.
2. Check coolant in the reserve tank daily (Figure 34). Make sure the level is between the FULL (H) and LOW (L) markings. Fill reserve tank with a mixture of 50/50 antifreeze/water.

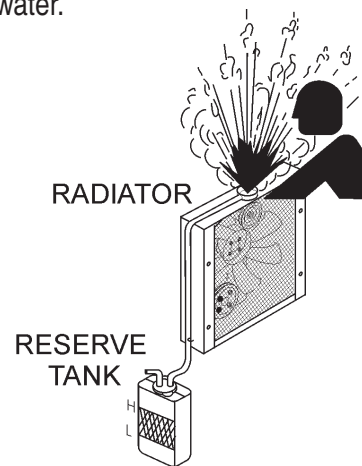

Figure 34. Radiator/Reserve Tank

Flushing Out Radiator and Replacing Coolant

1. Remove radiator coolant plug (Figure 35) located at the bottom of the generator enclosure and drain radiator coolant. Open the radiator cap while draining. Remove the overflow tank and drain.

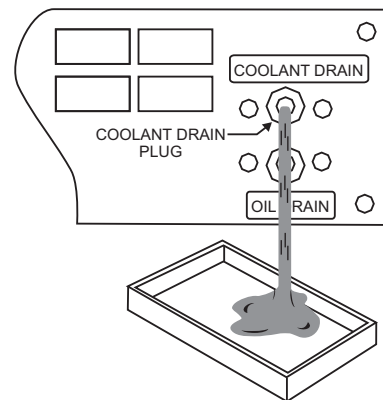



Figure 35. Coolant Drain Plug

2. Flush the radiator by running clean tap water through radiator until signs of rust and dirt are removed. **DO NOT** clean radiator core with any objects, such as a screwdriver.
3. Check hoses for softening and kinks. Check clamps for signs of leakage.
4. Tighten coolant drain plug and reinstall the overflow tank.
5. Fill with coolant as recommended by the engine manufacturer.
6. Close radiator cap tightly.

WARNING



Allow engine to **cool** when flushing out radiator. Flushing the radiator while hot could cause serious burns from water or steam.

RADIATOR CLEANING

The radiator (Figure 36) should be sprayed (cleaned) with a high pressure washer when excessive amounts of dirt and debris have accumulated on the cooling fins or tube. When using a high pressure washer, stand at least 5 feet (1.5 meters) away from the radiator to prevent damage to the fins and tube.

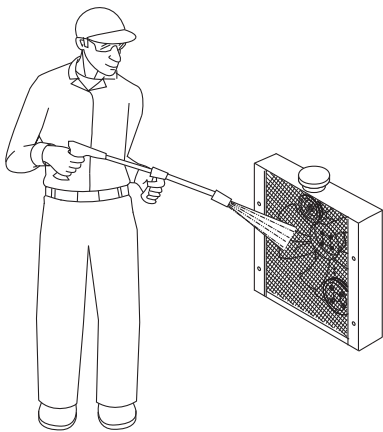

Figure 36. Radiator Cleaning

GENERATOR STORAGE

For long term storage of the generator the following is recommended:

- Drain the fuel tank completely. Treat with a fuel stabilizer if necessary.
- Completely drain the oil from the crankcase and refill if necessary with fresh oil.
- Clean the entire generator, internal and external.
- Cover the generating set and store in a clean, dry place.
- Disconnect the **negative** battery cable from the battery.
- Make sure engine coolant is at proper level.
- If generator is mounted on a trailer, jack trailer up and place on blocks so tires do not touch the ground or block and completely remove the tires.

MAINTENANCE (TRAILER)

TRAILER MAINTENANCE

The following trailer maintenance guidelines are intended to assist the operator in preventive maintenance.

Adjustable Channel

Your trailer may be equipped with an adjustable channel (Figure I) that allows the coupler to be raised or lowered to a desired height. Periodically check the channel bolts for damage or loosening.

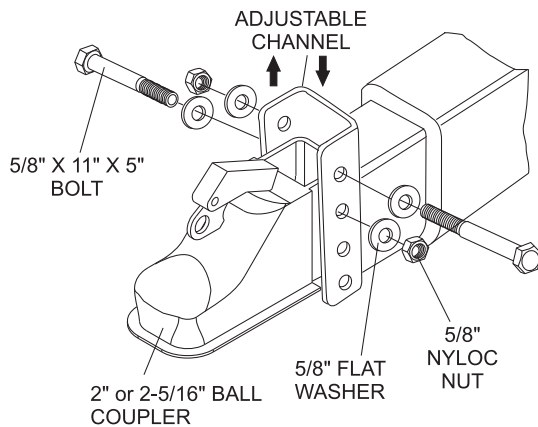

Figure I. Adjustable Channel

Wheel Bearings

Wheel bearings (Figure II) must be inspected and lubricated once a year or 12,000 miles to insure safe operation of your trailer.

If trailer wheel bearings are immersed in water, they must be replaced.

! DANGER

If trailer wheels are under water for a long period of time, wheel bearings may fail. If this is the case, service wheel bearings immediately.

The possibility exists of the wheels falling off causing equipment damage and severe bodily harm even death!

If the trailer has not been used for an extended amount of time, have the bearings inspected and packed more frequently, at least every six months and prior to use.

Follow the steps below to disassemble the wheel hub and service the wheel bearings. See Figure II.

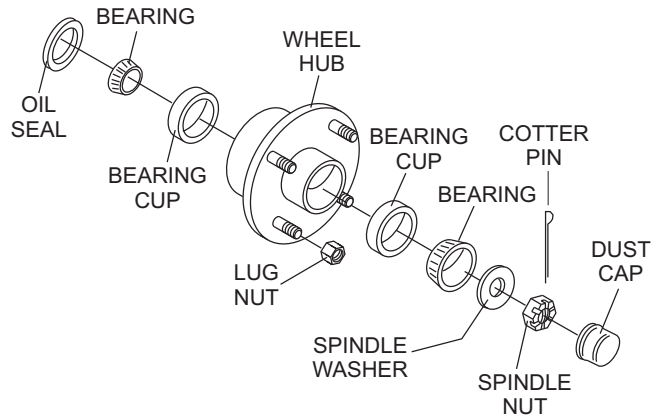

Figure II. Wheel Hub Components

- After removing the dust cap, cotter pin, spindle nut and spindle washer, remove the hub to inspect the bearings for wear and damage.
- Replace bearings that have flat spots on rollers, broken roller cages, rust or pitting. Always replace bearings and cups in sets. The inner and outer bearings are to be replaced at the same time.
- Replace seals that have nicks, tears or wear.
- Lubricate the bearings with a high quality EP-2 automotive wheel bearing grease.

Wheel Hub Adjustment

Every time the wheel hub is removed and the bearings are reassembled, follow the steps below to check the wheel bearings for free running and adjust.

- Turn the hub slowly, by hand, while tightening the spindle nut until you can no longer turn the hub by hand.
- Loosen the spindle nut just until you are able to turn it (the spindle nut) by hand. Do not turn the hub while the spindle nut is loose.
- Install a new cotter pin through the spindle nut and axle.
- Check the adjustments. Both the hub and the spindle nut should be able to move freely (the spindle nut motion will be limited by the cotter pin).

MAINTENANCE (TRAILER)

DANGER

NEVER crawl under the trailer unless it is on firm and level ground and resting on properly placed and secured jackstands.

The possibility exists of the trailer falling thus causing equipment damage and severe bodily harm even death!

DANGER

When performing trailer inspection and maintenance activities, you must jack up the trailer using jacks and jackstands.

When jacking and using jackstands, place them so as to clear wiring, brake lines, and suspension parts (i.e., springs, torsion bars). Place jacks and jackstands inside of the perimeter strip on the supporting structure to which the axles are attached.

DANGER

Improper weld repair will lead to early failure of the trailer structure and can cause serious injury or death.

DO NOT repair cracked or broken welds unless you have a certified welder perform the repair. If not, have the welds repaired by your dealer.

WARNING

If the trailer is involved in an accident, have it inspected immediately by qualified personnel. In addition, the trailer should be inspected annually for signs of wear or deformations.

Leaf Suspension

The leaf suspension springs and associated components (Figure III) should be visually inspected every 6,000 miles for signs of excessive wear, elongation of bolt holes, and loosening of fasteners. Replace all damaged parts (suspension) immediately.

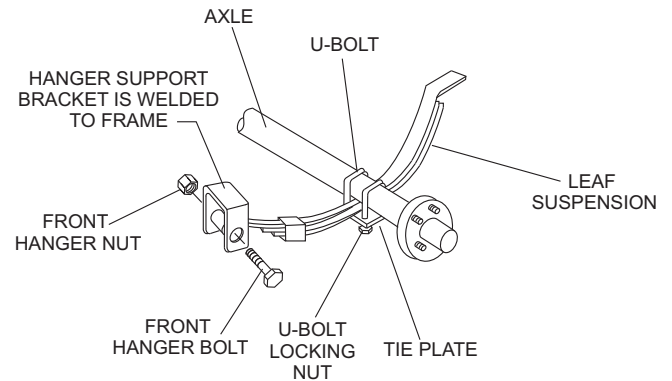

Figure III. Leaf Suspension Components

DANGER

Worn or broken suspension parts can cause loss of control, damage to equipment and severe bodily injury, even death!

Check suspension regularly.

TRAILER GUIDELINES

The following guidelines are intended to assist the operator in the operation and handling of a trailer.

Safety precautions should be followed at all times when operating a trailer. Failure to read, understand and follow the safety guidelines could result in injury to yourself and others. Loss of control of the trailer or tow vehicle can result in death or serious injury.

COMMON CAUSES FOR LOSS OF TRAILER

- Driving too fast for the conditions (maximum speed when towing a trailer is 55 mph).
- Overloading the trailer or loading the trailer unevenly.
- Trailer improperly coupled to the hitch.
- No braking on trailer.
- Not maintaining proper tire pressure.
- Not keeping lug nuts tight.
- Not properly maintaining the trailer structure.
- Ensure machine is towed level to tow vehicle.

TRAILER TOWING GUIDELINES

- Recheck the load tiedowns to make sure the load will not shift during towing.
- Before towing, check coupling, safety chain, safety brake, tires, wheels and lights.
- Check the lug nuts or bolts for tightness.
- Check coupler tightness after towing 50 miles.
- Use your mirrors to verify that you have room to change lanes or pull into traffic.
- Use your turn signals well in advance. Allow plenty of stopping space for your trailer and tow vehicle.
- Allow plenty of stopping space for your trailer and tow vehicle.
- **DO NOT** drive so fast that the trailer begins to sway due to speed.
- Allow plenty of room for passing. A rule of thumb is that the passing distance with a trailer is 4 times the passing distance without the trailer.

- Shift your automatic transmission into a lower gear for city driving.
- **ALWAYS** use lower gears for climbing and descending grades.
- **DO NOT** ride the brakes while descending grades, they may get so hot that they stop working. Then you will potentially have a runaway tow vehicle and trailer.
- To conserve fuel, don't use full throttle to climb a hill. Instead, build speed on the approach.
- Slow down for bumps in the road. Take your foot off the brake when crossing the bump.
- **DO NOT** brake while in a curve unless absolutely necessary. Instead, slow down before you enter the curve and power through the curve. This way, the towing vehicle remains in charge.
- **DO NOT** apply the brakes to correct extreme trailer swaying. Continued pulling of the trailer, and even slight acceleration, will provide a stabilizing force.
- Anticipate the trailer "swaying." Swaying is the trailer reaction to the air pressure wave caused by passing trucks and buses. Continued pulling of the trailer provides a stabilizing force to correct swaying. **DO NOT** apply the brakes to correct trailer swaying.
- Use lower gear when driving down steep or long grades. Use the engine and transmission as a brake. Do not ride the brakes, as they can overheat and become ineffective.
- Be aware of your trailer height, especially when approaching roofed areas and around trees.
- Make regular stops, about once each hour. Confirm that:
 - Coupler is secure to the hitch and is locked.
 - Electrical connectors are secure.
 - There is appropriate slack in the safety chains.
 - There is appropriate slack in the breakaway switch pullpin cable.
 - Tires are not visibly low on pressure.

TRAILER GUIDELINES

DRIVING CONDITIONS

When towing a trailer, you will have decreased acceleration, increased stopping distance, and increased turning radius (which means you must make wider turns to keep from hitting curbs, vehicles, and anything else that is on the inside corner). In addition, you will need a longer distance to pass, due to slower acceleration and increased length.

- Be alert for slippery conditions. You are more likely to be affected by slippery road surfaces when driving a tow vehicle with a trailer, than driving a tow vehicle without a trailer.
- Check rearview mirrors frequently to observe the trailer and traffic.
- **NEVER** drive faster than what is safe.

WARNING

Driving too fast for severe road conditions can result in loss of control and cause death or serious injury.

Decrease your speed as road, weather, and lighting conditions deteriorate.

Always check for local trailer tow speed limits in your area.

WARNING

Do not transport people on the trailer. The transport of people puts their lives at risk and may be illegal.

COUPLING TO THE TOW VEHICLE

Follow all of the safety precautions and instructions in this manual to ensure safety of persons, equipment, and satisfactory life of the trailer. Always use an adequate tow vehicle and hitch. If the vehicle or hitch is not properly selected and matched to the Gross Vehicle Weight Rating (GVWR) of your trailer, you can cause an accident that could lead to death or serious injury.

If you already have a tow vehicle, know your vehicle tow rating and make certain the trailer's rated capacity is less than or equal to the tow vehicle's rated towing capacity. If you already have (or plan to buy) a trailer, make certain that the tow rating of the tow vehicle is equal to or greater than that of the trailer.

The trailer VIN tag contains the critical safety information

for the use of your trailer. Again, be sure your hitch and tow vehicle are rated for the Gross Vehicle Weight Rating of your trailer.

WARNING

Proper selection and condition of the coupler and hitch are essential to safely towing your trailer. A loss of coupling may result in death or serious injury.

- Be sure the hitch load rating is equal to or greater than the load rating of the coupler.
- Be sure the hitch size matches the coupler size.
- Observe the hitch for wear, corrosion and cracks before coupling. Replace worn, corroded or cracked hitch components before coupling the trailer to the tow vehicle.
- Be sure the hitch components are tight before coupling the trailer to the tow vehicle.

WARNING

An improperly coupled trailer can result in death or serious injury.

DO NOT move the trailer until:

- The coupler is secured and locked to hitch.
- The safety chains are secured to the tow vehicle.
- The trailer jack(s) are fully retracted.

DO NOT tow the trailer on the road until:

- Tires and wheels are checked.
- The trailer brakes are checked.
- The breakaway switch is connected to the tow vehicle.
- The load is secured to the trailer.
- The trailer lights are connected and checked.

WARNING

Use of a hitch with a load rating less than the load rating of the trailer can result in loss of control and may lead to death or serious injury.

Use of a tow vehicle with a towing capacity less than the load rating of the trailer can result in loss of control, and may lead to death or serious injury.

Be sure your hitch and tow vehicle are rated for the Gross Vehicle Weight Rating of your trailer.

TRAILER GUIDELINES

INOPERABLE BRAKES, LIGHTS OR MIRRORS

Be sure that the brakes and all of the lights on your trailer are functioning properly before towing your trailer. Check the trailer taillights by turning on your tow vehicle headlights. Check the trailer brake lights by having someone step on the tow vehicle brake pedal while you look at trailer lights. Do the same thing to check the turn signal lights. See Trailer Wiring Diagram section in this manual.

Standard mirrors usually do not provide adequate visibility for viewing traffic to the sides and rear of a towed trailer. You must provide mirrors that allow you to safely observe approaching traffic.

WARNING

Improper electrical connection between the tow vehicle and the trailer will result in inoperable lights and can lead to collision.

Before each tow, check that the tail lights, brake lights and turn signals work.

TRAILER TOWING TIPS

Driving a vehicle with a trailer in tow is vastly different from driving the same vehicle without a trailer in tow. Acceleration, maneuverability and braking are all diminished with a trailer in tow.

It takes longer to get up to speed, you need more room to turn and pass, and more distance to stop when towing a trailer. You will need to spend time adjusting to the different feel and maneuverability of the tow vehicle with a loaded trailer.

Because of the significant differences in all aspects of maneuverability when towing a trailer, the hazards and risks of injury are also much greater than when driving without a trailer. You are responsible for keeping your vehicle and trailer in control, and for all the damage that is caused if you lose control of your vehicle and trailer.

As you did when learning to drive an automobile, find an open area with little or no traffic for your first practice trailering. Of course, before you start towing the trailer, you must follow all of the instructions for inspection, testing, loading and coupling. Also, before you start towing, adjust the mirrors so you can see the trailer as well as the area to the rear of it.

Drive slowly at first, 5 mph or so, and turn the wheel to get the feel of how the tow vehicle and trailer combination responds. Next, make some right and left hand turns. Watch in your side mirrors to see how the trailer follows the tow vehicle. Turning with a trailer attached requires more room.

Stop the rig a few times from speeds no greater than 10 mph. If your trailer is equipped with brakes, try using different combinations of trailer brake and tow vehicle brake. Note the effect that the trailer brakes have when they are the only brakes used. When properly adjusted, the trailer brakes will come on just before the tow vehicle brakes.

It will take practice to learn how to back up a tow vehicle with a trailer attached. Take it slow. Before backing up, get out of the tow vehicle and look behind the trailer to make sure that there are no obstacles.

Some drivers place their hands at the bottom of the steering wheel, and while the tow vehicle is in reverse, “think” of the hands as being on the top of the wheel. When the hands move to the right (counterclockwise, as you would do to turn the tow vehicle to the left when moving forward), the rear of the trailer moves to the right. Conversely, rotating the steering wheel clockwise with your hands at the bottom of the wheel will move the rear of the trailer to the left while backing up.

If you are towing a bumper hitch rig, be careful not to allow the trailer to turn too much because it will hit the rear of the tow vehicle. To straighten the rig, either pull forward or turn the steering wheel in the opposite direction.

TRAILER VIN TAG

Figure A below is a sample of the Vehicle Identification Number (VIN) Tag which is typically located on the left front of the trailer. See Figure B for location.

UFACTURED BY / FABRIQUE PAR:		DATE	
R / PNRV	KG (LB)		
R (EACH AXLE) / PNRB (CHAQUE ESSIEU)	KG (LB)	TIRES / PNEU	
/ JANTB			
INFL. PRESS. / PRESS. DE GONFL. A FROID	KPA (PSI / LPO	<input type="checkbox"/> SINGLE <input type="checkbox"/> DUAL
VEHICLE CONFORMS TO ALL APPLICABLE U.S. FEDERAL MOTOR VEHICLE SAFETY STANDARDS IN EFFECT ON THE DATE OF MANUFACTURE SHOWN ABOVE.			
VEHICLE CONFORMS TO ALL APPLICABLE STANDARDS PRESCRIBED UNDER THE CANADIAN MOTOR VEHICLE SAFETY REGULATIONS IN EFFECT ON THE DATE OF MANUFACTURE. - CE VEHICULE EST			
D'RIE A TOUTES LES NORMES QUI LUI SONT APPLICABLES EN VERTU DU REGLEMENT SUR LA SECURITE DES VEHICULES AUTOMOBILES DU CANADA EN VIGUEUR A LA DATE DE SA FABRICATION.			
/ N.I.N.:		TYPE / TYPE: TRAILER TRA / REM	FD-306 REV A

Figure A. Vehicle VIN Tag

TRAILER GUIDELINES

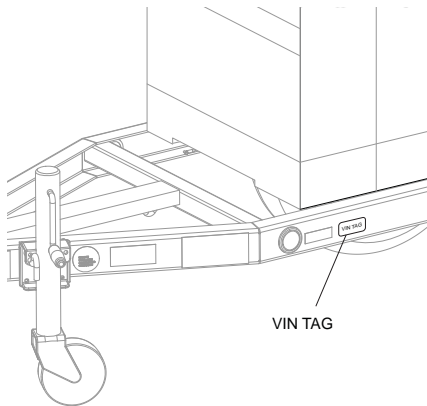

Figure B. VIN Tag Location

The trailer VIN Tag contains the following critical safety information for the use of your trailer.

GAWR: The maximum gross weight that an axle can support. It is the lowest of axle, wheel, or tire rating.

Usually, the tire or wheel rating is lower than the axle rating, and determines GAWR.

GVWR: The maximum allowable gross weight of the trailer and its contents. The gross weight of the trailer includes the weight of the trailer and all of the items within it. GVWR is sometimes referred to as GTWR (Gross Trailer Weight Rating), or MGTW (Maximum Gross Trailer Weight). GVWR, GTWR and MGTW are all the same rating.

The sum total of the GAWR for all trailer axles may be less than the GVWR for the trailer, because some of the trailer load is to be carried by the tow vehicle, rather than by the trailer axle(s). The total weight of the cargo and trailer must not exceed the GVWR, and the load on an axle must not exceed its GAWR.

PSIC: The tire pressure (psi) measured when cold.

VIN: The Vehicle Identification Number.

EMPTY WEIGHT: Some information that comes with the trailer (such as the Manufacturer's Statement of Origin) is not a reliable source for "empty" or "net" weight. The shipping documents list average or standard weights and your trailer may be equipped with options.

To determine the "empty" or "net" weight of your trailer, weigh it on an axle scale. To find the weight of the trailer using an axle scale, you must know the axle weights of your tow vehicle without the trailer coupled. Some of the trailer weight will be transferred from the trailer to the tow vehicle axles, and an axle scale weighs all axles, including the tow vehicle axles.

TOW VEHICLE

The towing hitch attached to your tow vehicle must have a capacity equal to or greater than the load rating of the trailer you intend to tow. The hitch capacity must also be matched to the tow vehicle capacity. Your vehicle dealer can provide and install the proper hitch on your tow vehicle.

SUSPENSION SYSTEM

Sway bars, shock absorbers, heavy duty springs, heavy duty tires and other suspension components may be required to sufficiently tow the trailer and pump.

SIDE VIEW MIRRORS

The size of the trailer that is being towed and your state law regulations determine the size of the mirrors. However, some states prohibit extended mirrors on a tow vehicle, except while a trailer is actually being towed. In this situation, detachable extended mirrors are necessary. Check with your dealer or the appropriate state agency for mirror requirements.

HEAVY DUTY FLASHER

A Heavy Duty Flasher is an electrical component that may be required when your trailer turn signal lights are attached to the tow vehicle flasher circuit.

ELECTRICAL CONNECTOR

An Electrical Connector connects the lights on the trailer to the lights on the towing vehicle.

EMERGENCY FLARES AND TRIANGLE REFLECTORS

It is wise to carry these warning devices even if you are not towing a trailer. It is particularly important to have these when towing a trailer because the hazard flashers of your towing vehicle will not operate for as long a period of time when the battery is running both the trailer lights and tow vehicle lights.

TRAILER GUIDELINES

SAFETY CHAINS

If the coupler connection comes loose, the safety chains can keep the trailer attached to the tow vehicle. With properly rigged safety chains, it is possible to keep the tongue of the trailer from digging into the road pavement, even if the coupler-to-hitch connection comes apart.

JACKSTAND

A device on the trailer that is used to raise and lower the coupler. The jack is sometimes called the “landing gear” or the “tongue jack”.

COUPLER TYPES

Two types of coupler used with the trailer are discussed below.

- Ball Hitch Coupler
- Pintel Eye Coupler

BALL HITCH COUPLER

A ball hitch coupler (Figure C) connects to a ball that is located on or under the rear bumper of tow vehicle. This system of coupling a trailer to a tow vehicle is sometimes referred to as “bumper pull.”

A ball hitch trailer may be fitted with a tongue jack that can raise and lower the coupler. The tongue jack is mounted to the A-frame (front or tongue) part of the trailer. By rotating the jack handle clockwise, the jack will extend and raise the tongue of the trailer.

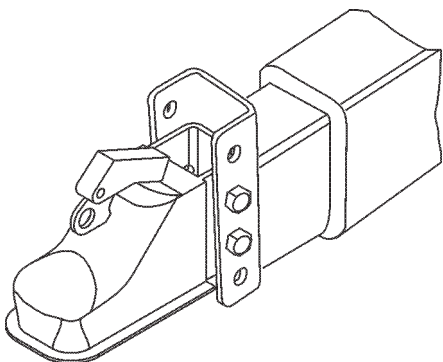

Figure C. Ball Hitch Coupler

Before each tow, coat the ball with a thin layer of automotive bearing grease to reduce wear and ensure proper operation.

Check the locking device that secures the coupler to the ball for proper operation.

If you see or feel evidence of wear, such as flat spots, deformations, pitting or corrosion, on the ball or coupler, immediately have your dealer inspect them to determine the proper action to prevent possible failure of the ball and coupler system. All bent or broken coupler parts must be replaced before towing the trailer.

The coupler handle lever must be able to rotate freely and automatically snap into the latched position. Oil the pivot points, sliding surfaces, and spring ends with SAE 30W motor oil. Keep the ball socket and latch mechanism clean. Dirt or contamination can prevent proper operation of the latching mechanism.

The load rating of the coupler and the necessary ball size are listed on the trailer tongue. You must provide a hitch and ball for your tow vehicle where the load rating of the hitch and ball is equal to or greater than that of your trailer.

Also, the ball size must be the same as the coupler size. If the hitch ball is too small, too large, is underrated, is loose or is worn, the trailer can come loose from the tow vehicle and may cause death or serious injury.

THE TOW VEHICLE, HITCH AND BALL MUST HAVE A RATED TOWING CAPACITY EQUAL TO OR GREATER THAN THE TRAILER Gross Vehicle Weight Rating (GVWR). IT IS ESSENTIAL THAT THE HITCH BALL BE OF THE SAME SIZE AS THE COUPLER.

The ball size and load rating (capacity) are marked on the ball. Hitch capacity is marked on the hitch.

! WARNING

Coupler-to-hitch mismatch can result in uncoupling, leading to death or serious injury.

Be sure the **LOAD RATING** of the hitch ball is equal or greater than the load rating of the coupler.

Be sure the **SIZE** of the hitch ball matches the size of the ball coupler.

TRAILER GUIDELINES

WARNING

A worn, cracked or corroded hitch ball can fail while towing and may result in death or serious injury.

Before coupling trailer, inspect the hitch ball for wear, corrosion and cracks.

Replace worn or damaged hitch ball.

WARNING

A loose hitchball nut can result in uncoupling, leading to death or serious injury.

Be sure the hitch ball is tight to the hitch before coupling the trailer.

- Rock the ball to make sure it is tightened to the hitch, and visually check that the hitch ball nut is solid against the lock washer and hitch frame.
- Wipe the inside and outside of the coupler. Clean and visually inspect it for cracks and deformations. Feel the inside of the coupler for worn spots and pits.
- Be sure the coupler is secured tightly to the tongue of the trailer. All coupler fasteners must be visibly solid against the trailer frame.
- The bottom surface of the coupler must be above the top of the hitch ball. Use the tongue jackstand to support the trailer tongue. Wood or concrete blocks may also be used.

Coupling the Trailer to the Tow Vehicle (Ball Coupler)

- Lubricate the hitch ball and the inside of the coupler with a thin layer of automotive bearing grease.
- Slowly back up the tow vehicle so that the hitch ball is near or aligned under the coupler.
- Using the jackstand at the front of trailer (tongue), turn the jackstand crank handle to raise the trailer. If the ball coupler does not line up with the hitch ball, adjust the position of the tow vehicle.
- Open the coupler locking mechanism. Ball couplers have a locking mechanism with an internal moving piece and an outside handle. In the open position, the coupler is able to drop fully onto the hitch ball.

- Lower the trailer (Figure D) until the coupler fully engages the hitch ball.

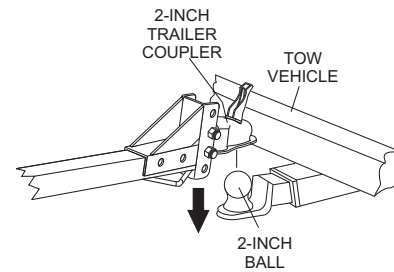

Figure D. Ball Hitch Coupling Mechanism

- Engage the coupler locking mechanism. In the engaged position, the locking mechanism securely holds the coupler to the hitch ball.
- Insert a pin or lock through the hole in the locking mechanism.
- Be sure the coupler is all the way on the hitch ball and the locking mechanism is engaged. A properly engaged locking mechanism will allow the coupler to raise the rear of the tow vehicle. Using the trailer jackstand, verify that you can raise the rear of the tow vehicle by 1 inch after the coupler is locked to the hitch.
- Lower the trailer so that its entire tongue weight is held by the hitch.
- Raise the jackstand to a height where it will not interfere with the road.

NOTICE

Overloading can damage the tongue jack. **DO NOT** use the tongue jack to raise the tow vehicle more than one inch.

If the coupler cannot be secured to the hitch ball, do not tow the trailer. Call your dealer for assistance. Lower the trailer so that its entire tongue weight is held by the hitch and continue retracting the jack to its fully retracted position.

TRAILER GUIDELINES

Attaching Safety Chain

Visually inspect the safety chains and hooks for wear or damage. Replace worn or damaged safety chains and hooks before towing.

Attach the safety chains so that they:

- Cross underneath the coupler. See Figure E.

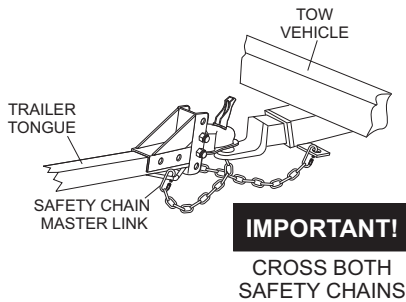

Figure E. Attaching Safety Chain (Ball Hitch)

- Loop around a frame member of the tow vehicle or holes provided in the hitch system (DO NOT attach them to an interchangeable part of the hitch assembly).
- Have enough slack to permit tight turns, but not be close to the road surface, so if the trailer uncouples, the safety chains can hold the tongue up above the road

WARNING

Improper rigging of the safety chains can result in loss of control of the trailer and tow vehicle, leading to death or serious injury, if the trailer uncouples from the tow vehicle.

- Fasten chains to frame of tow vehicle. DO NOT fasten chains to any part of the hitch unless the hitch has holes or loops specifically for that purpose.
- Cross chains underneath hitch and coupler with enough slack to permit turning and to hold tongue up, if the trailer comes loose.

Connecting Trailer Lights

Connect the trailer lights to the tow vehicle's electrical system using the electric connectors at the front of the trailer (tongue). Refer to the wiring diagram shown in the trailer wiring diagram section of this manual. Before towing the trailer check for the following:

- Running lights (turn on tow vehicle headlights).
- Brake Lights (step on tow vehicle brake pedal).

- Backup Lights (place tow vehicle gear shift in reverse).
- Turn Signals (activate tow vehicle directional signal lever).

WARNING

Improper electrical connection between the tow vehicle and the trailer will result in inoperable lights and electric brakes, and can lead to collision.

Before each tow:

- Check that the taillights, brake lights and turn signals work.
- Check that the electric brakes work by operating the brake controller inside the tow vehicle.

Uncoupling the Ball Hitch

Follow these steps to uncouple ball hitch from tow vehicle:

- Block trailer tires to prevent the trailer from rolling, before jacking the trailer up.
- Disconnect the electrical connector.
- Disconnect the breakaway brake switch cable. Promptly replace the pullpin in the switchbox.
- Before extending jackstand, make certain the ground surface below the jackstand foot will support the tongue load.
- Rotate the jackstand handle (or crank) clockwise. This will slowly extend the jack and transfer the weight of the trailer tongue to the jack.

PINTLE HITCH COUPLER

A pintle eye coupler (Figure F) connects to a pintle-hook hitch that is located on or under the rear bumper of the tow vehicle. This system of coupling a trailer to a tow vehicle is sometimes referred to as a “lunette eye, tow ring or G.I. hitch.”

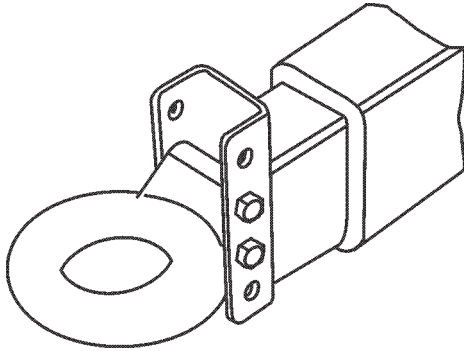

Figure F. Pintle Hitch Coupler

A pintle hitch trailer may be fitted with a tongue jackstand that can raise and lower the coupler. The tongue jack is mounted to the A-frame (front or tongue) part of the trailer. By rotating the jack handle clockwise, the jack will extend and raise the tongue of the trailer.

The load rating of the coupler and the necessary pintle hitch size are listed on the trailer tongue. You must provide a pintle hitch and pintle coupler for your tow vehicle, where the load rating of the pintle hitch and pintle coupler is equal to or greater than that of your trailer.

Also, the pintle hitch size must be the same as the pintle coupler size. If the hitch is too small, too large, underrated, loose or worn, the trailer can come loose from the tow vehicle, and may cause death or serious injury.

Pintle Coupler and Pintle Hook

Before each tow, check the locking device that secures the coupler to the pintle hook assembly.

The pintle hook lever must be able to operate freely and automatically snap into place into the latched position. Lightly oil the pivot points and sliding surfaces with SAE30W motor oil to prevent rust and help ensure proper operation of the latching mechanism.

If you see or feel evidence of wear, such as flat spots, deformations, pitting or corrosion, on the pintle hook or coupler, immediately have your dealer inspect them to determine the proper action to prevent possible failure of the ball and coupler system. All bent or broken coupler parts must be replaced before towing the trailer.

THE TOW VEHICLE, PINTLE HITCH AND PINTLE COUPLER MUST HAVE A RATED TOWING CAPACITY EQUAL TO OR GREATER THAN THE TRAILER Gross Vehicle Weight Rating (GVWR).

IT IS ESSENTIAL THAT THE PINTLE HITCH BE OF THE SAME SIZE AS THE PINTLE COUPLER.

The coupler size and load rating (capacity) are marked on the coupler. Hitch capacity is marked on the hitch.

WARNING

Coupler-to-hitch mismatch can result in uncoupling, leading to death or serious injury.

Be sure the **LOAD RATING** of the pintle hitch hook is equal or greater than the load rating of the pintle eye coupler.

Be sure the **SIZE** of the pintle hitch hook matches the size of the pintle eye coupler.

WARNING

A worn, cracked or corroded pintle hitch hook can fail while towing, and may result in death or serious injury.

Before coupling trailer, inspect the pintle hitch hook for wear, corrosion and cracks.

Replace worn or damaged pintle hitch hook.

- Rock the pintle eye coupler to make sure it is secured tightly to the hitch.
- Wipe the inside and outside of the pintle coupler. Clean and inspect it visually for cracks and deformations. Feel the inside of the coupler for worn spots and pits.
- Be sure the coupler is secured tightly to the tongue of the trailer. All coupler fasteners must be visibly solid against the trailer frame.

TRAILER GUIDELINES

- Raise the bottom surface of the coupler to be above the top of the pintle hitch hook. Use the tongue jackstand to support the trailer tongue. Wood or concrete blocks may also be used.

WARNING

A defective pintle hitch not properly fastened can result in uncoupling, leading to death or serious injury.

Be sure the pintle hook is securely tightened to the tow vehicle before coupling the trailer.

Coupling Trailer to Tow Vehicle (Pintle Coupler)

- Slowly back up the tow vehicle so that the pintle hitch hook is near or aligned under the pintle eye ring coupler.
- Using the jackstand at the front of trailer (tongue), turn the jackstand crank handle to raise the trailer. If the pintle eye coupler does not line up with the pintle hitch hook, adjust the position of the tow vehicle.
- OPEN the pintle hook locking mechanism (Figure G). Place the hook inside the eye coupler. CLOSE the pintle hook mechanism.

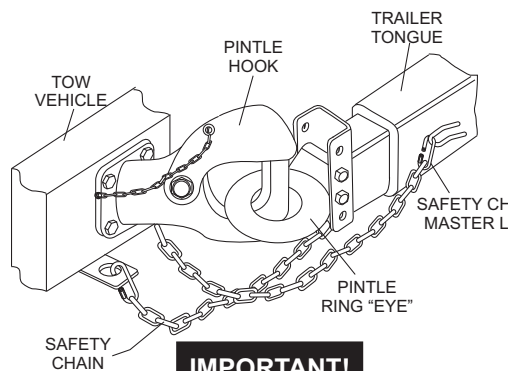

IMPORTANT!

CROSS BOTH

Figure G. Attaching Safety Chain (Pintle Hitch)

- Insert a pin or lock through the hole in the locking mechanism.
- Be sure the pintle hook is inserted completely through the eye ring and the locking mechanism is engaged. A properly engaged locking mechanism will allow the coupler to raise the rear of the tow vehicle. Using the trailer jack, test to see that you can raise the rear of the tow vehicle by 1-inch after the coupler is locked to the hitch.

- Lower the trailer so that its entire tongue weight is held by the hitch.
- Raise the jackstand to a height where it will not interfere with the road.

TIRE SAFETY

Unsafe Tires, Lug Nuts or Wheels

Trailer tires and wheels are more likely to fail than car tires and wheels because they carry a heavier load. Therefore, it is essential to inspect the trailer tires before each tow.

If a tire has a bald spot, bulge, cuts, is showing any cords, or is cracked, replace the tire before towing. If a tire has uneven tread wear, take the trailer to a dealer service center for diagnosis.

Uneven tread wear can be caused by tire imbalance, axle misalignment or incorrect inflation.

Tires with too little tread will not provide adequate tracking on wet roadways and can result in loss of control, leading to death or serious injury.

Improper tire pressure causes an unstable trailer and can result in a tire blowout and loss of control. Therefore, before each tow you must also check the tire pressure. Tire pressure must be checked when tires are cold.

Allow 3 hours cool-down after driving as much as 1 mile at 40 mph before checking tire pressure. Trailer tires will be inflated to higher pressures than passenger vehicle tires.

Since trailer wheels and lug nuts (or bolts) are subjected to greater side loads than automobile wheels, they are more prone to loosen. Before each tow, check to make sure they are tight.

The proper tightness (torque) for lug nuts is listed in the lug nut tightening section of this manual. Use a torque wrench to tighten the lug nuts. If you do not have a torque

TRAILER GUIDELINES

wrench, use a lug wrench (from your tow vehicle) and tighten the nuts as much as you can. Then have a service garage or trailer dealer tighten the lug nuts to the proper torque.

⚠ WARNING

Metal creep between the wheel rim and lug nuts will cause rim to loosen and could result in a wheel coming off, leading to death or serious injury.

Tighten lug nuts before each tow.

Lug nuts are also prone to loosen after first being assembled. When driving a new trailer (or after wheels have been remounted), check to make sure they are tight after the first 10, 25 and 50 miles of driving and before each tow thereafter.

Failure to perform this check can result in a wheel parting from the trailer and a crash, leading to death or serious injury.

⚠ WARNING

Lug nuts are prone to loosen after initial installation, which can lead to death or serious injury.

Check lug nuts for tightness on a new trailer or when wheel(s) have been remounted after the first 10, 25 and 50 miles of driving.

⚠ WARNING

Improper lug nut torque can cause a wheel parting from the trailer, leading to death or serious injury.

Be sure lug nuts are tight before each tow.

⚠ WARNING

Improper tire pressure can result in a blowout and loss of control, which can lead to death or serious injury.

Be sure tires are inflated to pressure indicated on side wall before towing trailer.

Determining Load Limit of Trailer

Determining the load limits of a trailer includes more than understanding the load limits of the tires alone. On all trailers there is a Federal certification/VIN label that is located on the forward half of the left (road) side of the unit.

This certification/VIN label will indicate the trailer's Gross Vehicle Weight Rating (GVWR). This is the most weight the fully loaded trailer can weigh. It will also provide the Gross Axle Weight Rating (GAWR). This is the most a the axle can weigh.

There is a vehicle placard (Figure H) located in the same location as the certification label described above. This placard provides tire and loading information. In addition, this placard will show a statement regarding maximum cargo capacity.

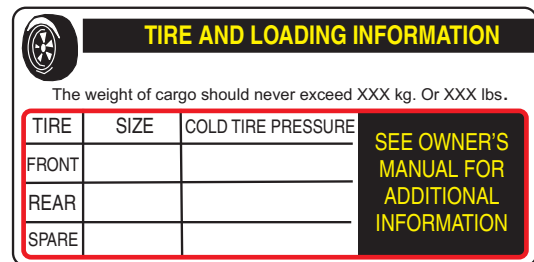

Figure H. Trailer Tire Placard

If additional work items (hoses, tools, clamps etc.) are going to be added to the trailer, be sure they are distributed evenly to prevent overloading front to back and side to side. Heavy items should be placed low and as close to the axle positions as reasonable. Too many items on one side may overload a tire.

Excessive loads and/or underinflation cause tire overloading and, as a result, abnormal tire flexing occurs. This situation can generate an excessive amount of heat within the tire. Excessive heat may lead to tire failure. It is the air pressure that enables a tire to support the load, so proper inflation is critical. The proper air pressure may be found on the certification/VIN label and/or on the Tire and Loading Information placard. This value should never exceed the maximum cold inflation pressure stamped on the tire.

Perform the following steps to determine the load limit of your trailer.

Step 1.

Locate the statement, "The weight of cargo should never exceed XXX kg or XXX lbs.," on your vehicle's Tire and Loading Information placard (Figure I). This value equals the available amount of equipment load capacity.

TRAILER GUIDELINES

Step 2.

Determine the weight of the equipment being loaded on the tow vehicle. That weight may not safely exceed the available equipment load capacity. The trailer's Tire Information Placard is attached adjacent to or near the trailer's VIN (Certification) label at the left front of the trailer (See Figure I).

Determining Load Limit of Tow Vehicle

Step 1.

Locate the statement, "The combined weight of occupants and cargo should never exceed XXX lbs.," on your vehicle's placard.

Step 2.

Determine the combined weight of the driver and passengers who will be riding in your vehicle.

Step 3.

Subtract the combined weight of the driver and passengers from XXX kilograms or XXX pounds.

Step 4.

The resulting figure equals the available amount of cargo and luggage capacity. For example, if the "XXX" amount equals 1400 lbs. and there will be five 150 lb. passengers in your vehicle, the amount of available cargo and luggage capacity is 650 lbs. ($1400 - 750 (5 \times 150) = 650$ lbs.).

Step 5.

Determine the combined weight of luggage and cargo being loaded on the vehicle. That weight may not safely exceed the available cargo and luggage capacity calculated in Step 4.

If your vehicle will be towing a trailer, load from your trailer will be transferred to your vehicle. Consult the tow vehicle's manual to determine how this weight transfer reduces the available cargo and luggage capacity of your vehicle.

Studies of tire safety show that maintaining proper tire pressure, observing tire and vehicle load limits (not carrying more weight in your vehicle than your tires or vehicle can safely handle), avoiding road hazards and inspecting tires for cuts, slashes and other irregularities are the most important things you can do to avoid tire failure, such as tread separation or blowout and flat tires. These actions,

along with other care and maintenance activities, can also:

- Improve vehicle handling.
- Help protect you and others from avoidable breakdowns and accidents.
- Improve fuel economy.
- Increase the tire life.

Use the information contained in this section to make tire safety a regular part of your vehicle maintenance routine. Recognize that the time you spend is minimal compared with the inconvenience and safety consequences of a flat tire or other tire failure.

TIRE FUNDAMENTALS

Federal law requires tire manufacturers to place standardized information on the sidewall of all tires (Figure I). This information identifies and describes the fundamental characteristics of the tire and also provides a tire identification number for safety standard certification and in case of a recall.

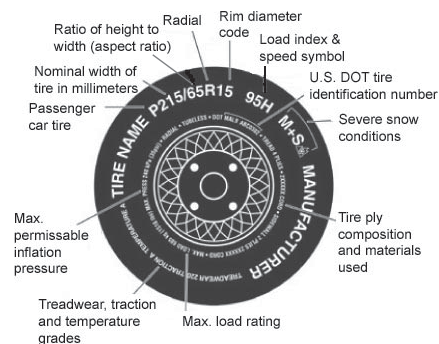

Figure I. Standard Tire Sidewall Information

P: The "P" indicates the tire is for passenger vehicles.

Next number: This three-digit number gives the width in millimeters of the tire from sidewall edge to sidewall edge. In general, the larger the number, the wider the tire.

Next number: This two-digit number, known as the aspect ratio, gives the tire's ratio of height to width. Numbers of 70 or lower indicate a short sidewall for improved steering response and better overall handling on dry pavement.

P: The "R" stands for radial. Radial ply construction of tires has been the industry standard for the past 20 years.

TRAILER GUIDELINES

Next number: This two-digit number is the wheel or rim diameter in inches. If you change your wheel size, you will have to purchase new tires to match the new wheel diameter.

Next number: This two- or three-digit number is the tire's load index. It is a measurement of how much weight each tire can support. You may find this information in your owner's manual. If not, contact a local tire dealer. *Note:* You may not find this information on all tires because it is not required by law.

M+S: The "M+S" or "M/S" indicates that the tire has some mud and snow capability. Most radial tires have these markings; hence, they have some mud and snow capability.

Speed Rating: The speed rating denotes the speed at which a tire is designed to be driven for extended periods of time. The ratings range from 99 miles per hour (mph) to 186 mph. These ratings are listed in Table A. *Note:* You may not find this information on all tires because it is not required by law.

Letter Rating	Speed Rating
Q	99 mph
R	106 mph
S	112 mph
T	118 mph
U	124 mph
H	130 mph
V	149 mph
W	168* mph
Y	186* mph

U.S. DOT Tire Identification Number: This begins with the letters "DOT" and indicates that the tire meets all federal standards. The next two numbers or letters are the plant code where it was manufactured, and the last four numbers represent the week and year the tire was built. For example, the numbers 3197 means the 31st week of 1997. The other numbers are marketing codes used at the manufacturer's discretion. This information is used to contact consumers if a tire defect requires a recall.

Tire Ply Composition and Materials Used: The number of plies indicates the number of layers of rubber-coated fabric

in the tire. In general, the greater the number of plies, the more weight a tire can support. Tire manufacturers also must indicate the materials in the tire, which include steel, nylon, polyester, and others.

Maximum Load Rating: This number indicates the maximum load in kilograms and pounds that can be carried by the tire.

Maximum Permissible Inflation Pressure: This number is the greatest amount of air pressure that should ever be put in the tire under normal driving conditions.

Uniform Tire Quality Grading Standards (UTQGS)

Treadwear Number: This number indicates the tire's wear rate. The higher the treadwear number is, the longer it should take for the tread to wear down. For example, a tire graded 400 should last twice as long as a tire graded 200.

Traction Letter: This letter indicates a tire's ability to stop on wet pavement. A higher graded tire should allow you to stop your car on wet roads in a shorter distance than a tire with a lower grade. Traction is graded from highest to lowest as "AA", "A", "B", and "C".

Temperature Letter: This letter indicates a tire's resistance to heat. The temperature grade is for a tire that is inflated properly and not overloaded. Excessive speed, underinflation or excessive loading, either separately or in combination, can cause heat build-up and possible tire failure. From highest to lowest, a tire's resistance to heat is graded as "A", "B", or "C".

Refer to Figure J for additional tire information for light trucks.

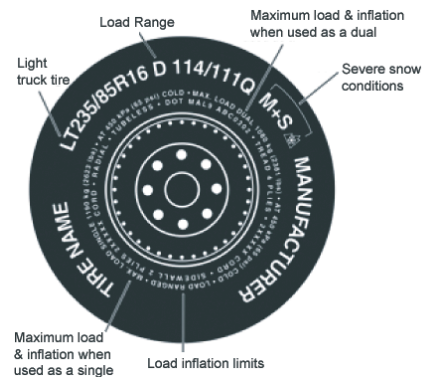

Figure J. UTQGS Tire Information

TRAILER GUIDELINES

Tires for light trucks have other markings besides those found on the sidewalls of passenger tires.

LT: The “LT” indicates the tire is for light trucks or trailers.

ST: An “ST” is an indication the tire is for trailer use only.

Max. Load Dual kg (lbs) at kPa (psi) Cold: This information indicates the maximum load and tire pressure when the tire is used as a dual, that is, when four tires are put on each rear axle (a total of six or more tires on the vehicle).

Max. Load Single kg (lbs) at kPa (psi) Cold: This information indicates the maximum load and tire pressure when the tire is used as a single.

Load Range: This information identifies the tire’s load-carrying capabilities and its inflation limits.

Tire Safety Tips

- Slow down if you have to go over a pothole or other object in the road.
- **DO NOT** run over curbs or other foreign objects in the roadway, and try not to strike the curb when parking.
- Check tire inflation pressure weekly during use to insure the maximum tire life and tread wear.
- **DO NOT** bleed air from tires when they are hot.
- Inspect tires for uneven wear patterns on the tread, cracks, foreign objects, or other signs of wear or trauma.
- Remove bits of glass and foreign objects wedged in the tread.
- Make sure your tire valves have valve caps.
- **ALWAYS** check tire pressure on tow vehicle and trailer before towing. Check tire pressure at least once a month.
- **DO NOT** overload tow vehicle. Check the tire information and loading placard for safe allowable tire loading conditions.

Tire Repair







The proper repair of a punctured tire requires a plug for the hole and a patch for the area inside the tire that surrounds the puncture hole. Punctures through the tread can be repaired if they are not too large, but punctures to the

sidewall should not be repaired. Tires must be removed from the rim to be properly inspected before being plugged and patched.

Replacing Worn or Damaged Tires

Replace the tire before towing the trailer if the tire treads have less than 1/16 inch depth or the telltale bands are visible. Check inflation pressure weekly during use to insure the maximum tire life and tread wear. A bubble, cut or bulge in a side wall can result in a tire blowout. Inspect both side walls of each tire for any bubble, cut or bulge; and replace a damaged tire before towing the trailer.

Table B below will help pinpoint the causes and solutions of tire wear problems.

Table B. Tire Wear Troubleshooting			
Wear Pattern		Cause	Solution
	Center Wear	Over inflation.	Adjust pressure to particular load per tire manufacturer.
	Edge Wear	Under inflation.	Adjust pressure to particular load per tire manufacturer.
	Side Wear	Loss of camber or overloading.	Make sure load does not exceed axle rating. Align wheels.
	Toe Wear	Incorrect toe-in.	Align wheels.
	Cupping	Out-of-balance.	Check bearing adjustment and balance tires.
	Flat Spots	Wheel lockup and tire skidding.	Avoid sudden stops when possible and adjust brakes.

WARNING

 **ALWAYS** wear safety glasses when removing or installing force fitted parts. **DO NOT** attempt to repair or modify a wheel. **DO NOT** install an inner-tube to correct a leak through through the rim. If the rim is cracked, the air pressure in the inner tube may cause pieces of the rim to explode (break off) with great force and cause serious eye or bodily injury.

TRAILER GUIDELINES

Wheel Rims

If the trailer has been struck, or impacted, on or near the wheels, or if the trailer has struck a curb, inspect the rims for damage (i.e. being out of round); and replace any damaged wheel. Inspect the wheels for damage every year, even if no obvious impact has occurred.

Wheels, Bearings and Lug Nuts

A loose, worn or damaged wheel bearing is the most common cause of brakes that grab.

To check wheel bearings, jack trailer and check wheels for side-to-side looseness. If the wheels are loose, or spin with a wobble, the bearings must be serviced or replaced. Check inflation pressure weekly during use to insure the maximum tire life and tread wear. Most trailer axles are built with sealed bearings that are not serviceable. Sealed bearings must be replaced as complete units.

WARNING

Lug nuts are prone to loosen after initial installation, which can lead to death or serious injury. Check all wheel lug nuts periodically.

Lug Nut Torque Requirements

It is extremely important to apply and maintain proper wheel mounting torque on the trailer. Be sure to use only the fasteners matched to the cone angle of the wheel. Proper procedure for attachment of the wheels is as follows:

1. Start all wheel lug nuts by hand.
2. Torque all lug nuts in sequence. See Figure K. DO NOT torque the wheel lug nuts all the way down. Tighten each lug nut in 3 separate passes as defined by Table C.

NOTICE

NEVER use an pneumatic air gun to tighten wheel lug nuts.

Over-tightening lug nuts will result in breaking the studs or permanently deforming the mounting stud holes in the wheels.

3. Check to see if the lug nuts are tight after the first 10, 25 and 50 miles of driving and before each tow thereafter

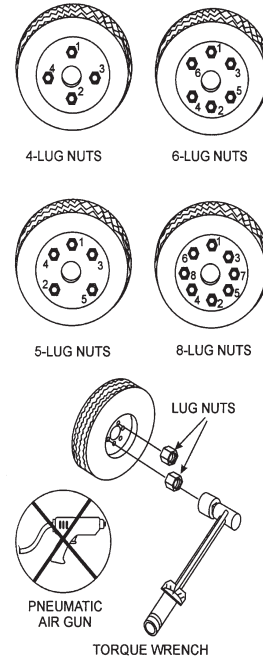

Figure K. Wheel Lug Nuts Tightening Sequence

Table C. Tire Torque Requirements

Wheel Size	First Pass FT-LBS	Second Pass FT-LBS	Third Pass FT-LBS
12"	20-25	35-40	50-65
13"	20-25	35-40	50-65
14"	20-25	50-60	90-120
15"	20-25	50-60	90-120
16"	20-25	50-60	90-120

Lights and Signals

Before each tow, check the trailer taillights, stoplights, turn signals and any clearance lights for proper operation.

Replace any broken or burned-out lamps as necessary. Check the wire harness for cuts, fraying or other damage. If it needs replacing, contact your dealer.

WARNING

Improper operating taillights, stoplights and turn signals can cause collisions.

Check all lights before each tow.

TRAILER WIRING DIAGRAM

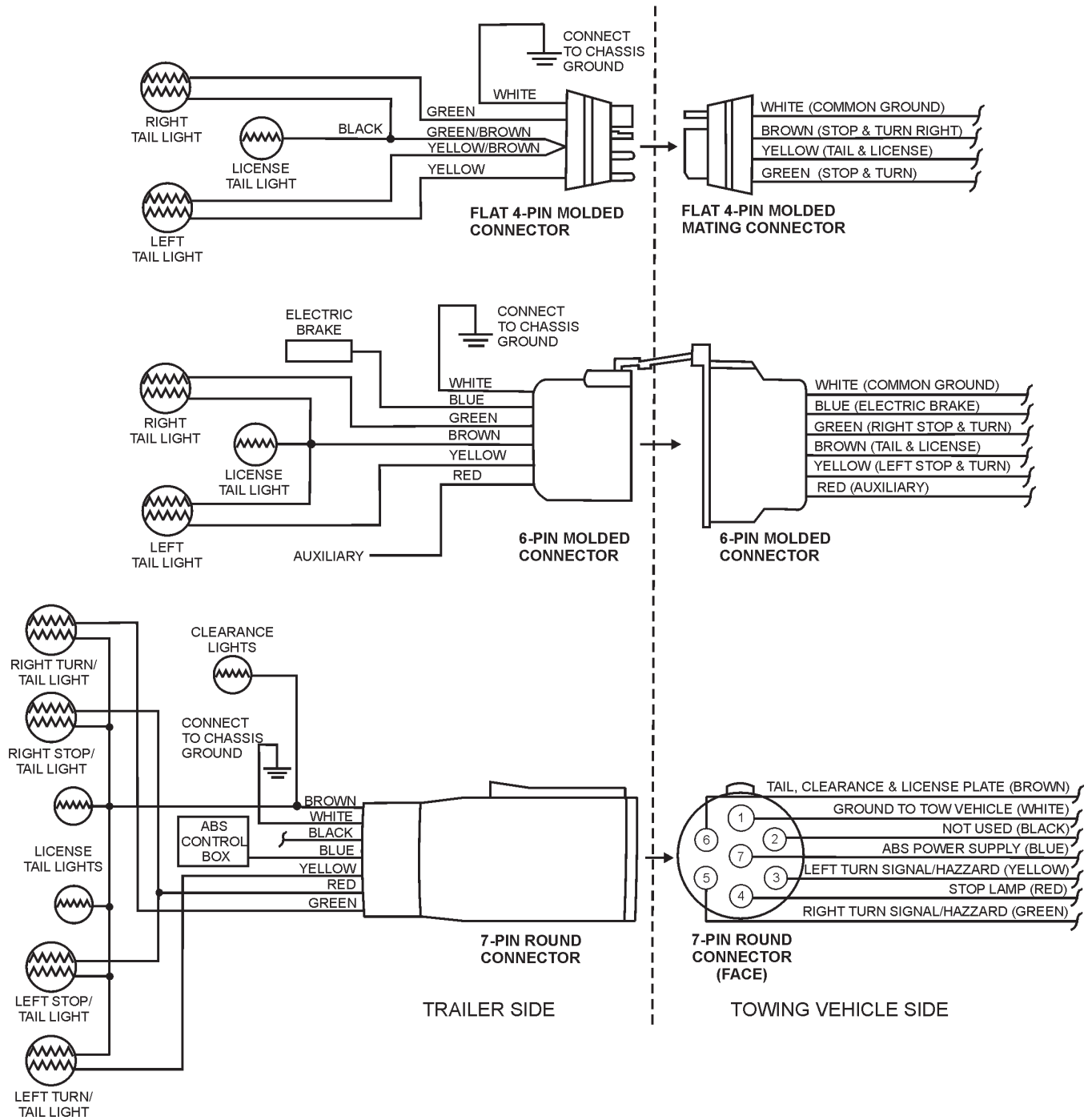
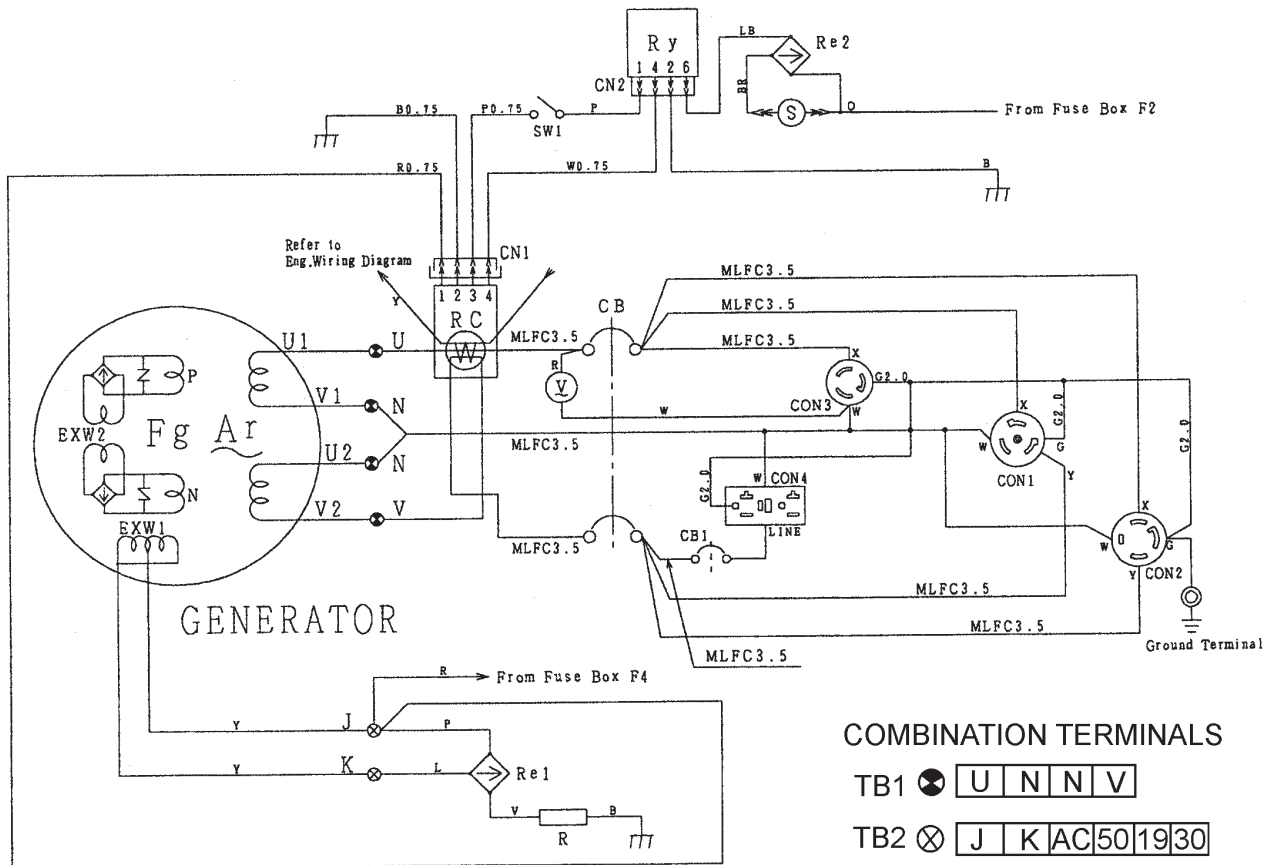
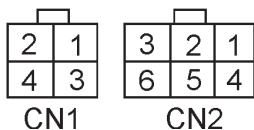

Figure 37. Trailer Wiring Diagram

GENERATOR WIRING DIGRAM



WIRING COLOR CODE	
SYMBOL	COLOR
B	BLACK
L	BLUE
BR	BROWN
G	GREEN
GR	GRAY
V	VIOLET
P	PINK
R	RED
W	WHITE
Y	YELLOW
LB	LIGHT BLUE
LG	LIGHT GREEN
O	ORANGE



SYMBOL	PARTS NAME
AR	ARMATURE WINDING
Eg	FIELD WINDING
EXW1~2	EXCITATION WINDING
V	AC VOLTMETER
RE1~2	RECTIFIER
CON1	RECEPTACLE (120/240V, 50 AMP)
CON2	RECEPTACLE (120/240V, 30 AMP)
CON3	RECEPTACLE (120V, 30 AMP)
CON4	RECEPTACLE (120V, 20 AMP-GFCI)
CB	MAIN CIRCUIT BREAKER (265V, 25 AMP)
CB	GFCI CIRCUIT BREAKER (250V, 20 AMP)
SW1	IDLE CONTROL SWITCH
RC	IDLE CONTROL DEVICE
S	SOLENOID
Ry	RELAY
R	RESISTOR

Figure 38. Generator Wiring Diagram (DA7000 SERIES)

ENGINE WIRING DIGRAM

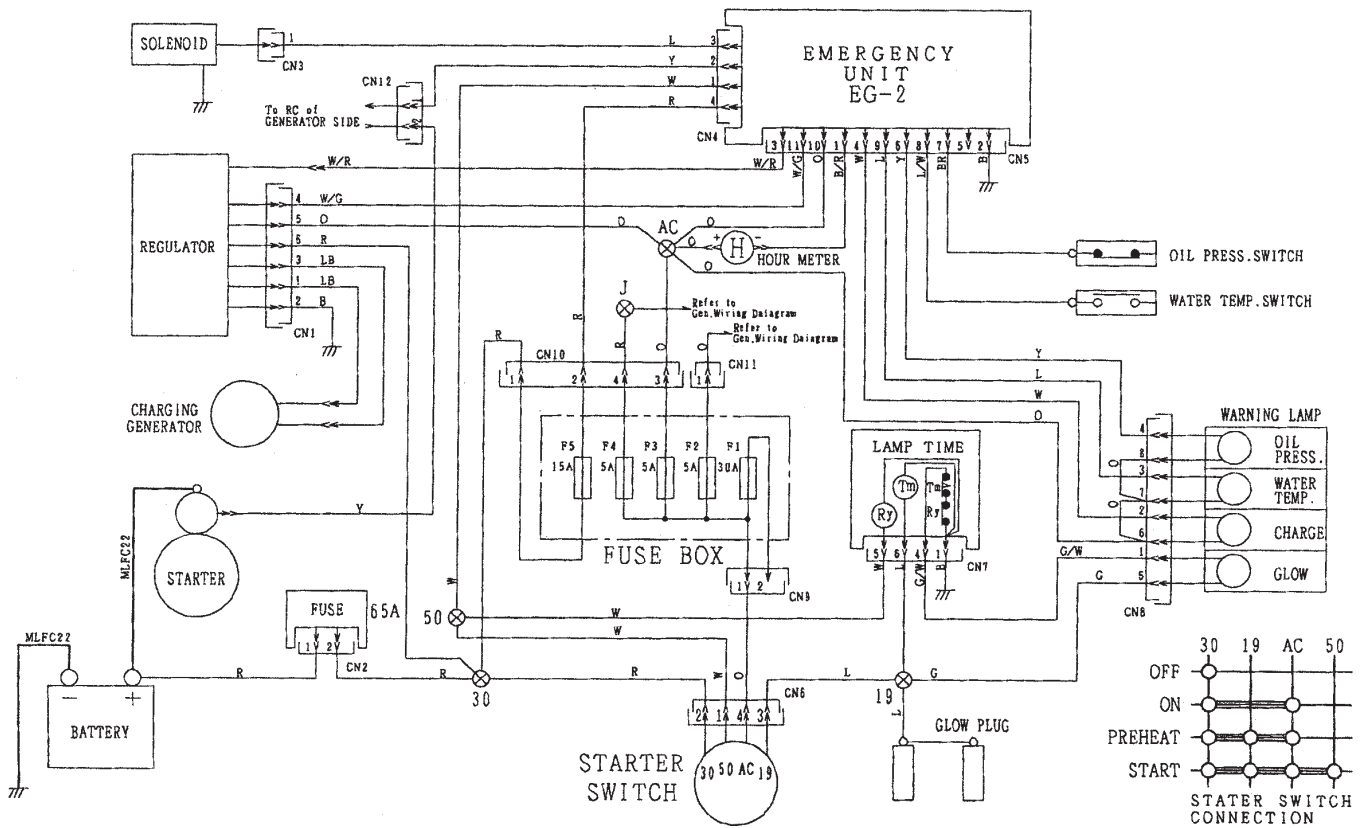

CONNECTOR VIEWED AT WINDING SIDE

WIRING COLOR CODE	
SYMBOL	COLOR
B	BLACK
L	BLUE
BR	BROWN
G	GREEN
GR	GRAY
V	VIOLET
P	PINK
R	RED
W	WHITE
Y	YELLOW
LB	LIGHT BLUE
LG	LIGHT GREEN
O	ORANGE

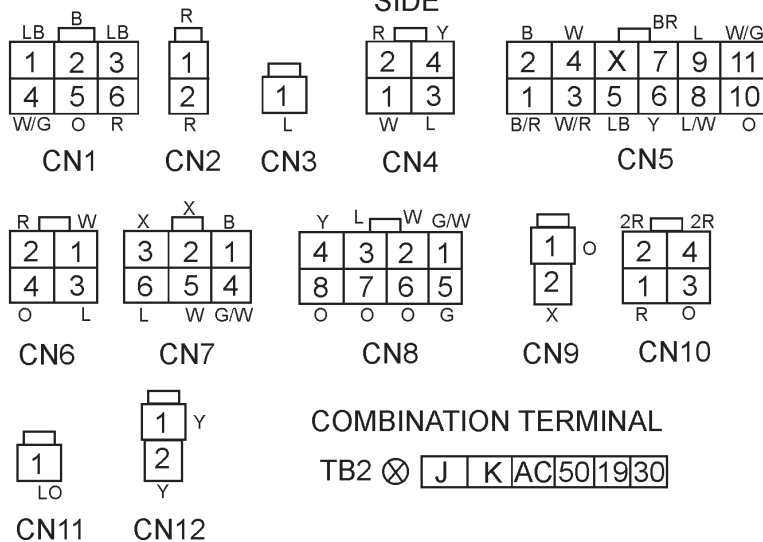

Figure 39. Engine Wiring Diagram

TROUBLESHOOTING (ENGINE AND GENERATOR)

Table 9. Engine and Generator Troubleshooting

SYMPTOM	POSSIBLE PROBLEM	SOLUTION
Engine fails to start and starter does not rotate.	Dead Battery?	Replace Battery.
	Defective Starter Switch?	Replace Switch.
	Defective Starter?	Replace Starter.
	Fuse F5 Burned Out?	Replace Fuse.
Engine fails to start and starter rotates.	Broken Pre-Heat Circuit?	Check Pre-Heat Circuit.
	No Fuel?	Add Fuel.
	Defective Wiring?	Check Wiring.
Engine starts "Idle Control Switch" is in OFF position and engine remains at low speed.	Defective Idle Control Switch?	Replace Switch.
	Idle Control Switch is in ON position?	Set Switch to OFF Position.
	Clogged Fuel Strainer?	Clean or Replace.
	Clogged Air Cleaner?	Clean or Replace.
	Defective Idle Control Device?	Replace.
	Disconnected Wiring?	Check and Repair Wiring.
Engine starts and "Idle Control Switch" is in OFF position. Engine speed rises and no voltage is present in AC power source.	No Voltage Present in AC Power source	Replace Rectifier (RE1).
	Defective Rotor?	Replace Rotor.
	Defective Voltmeter?	Replace Voltmeter.
	Disconnected Wiring?	Check and Repair Wiring.
	Layer Short-Circuit in armature winding?	Replace Armature.
Engine starts and "Idle Control Switch" is in OFF position . Engine speed rises and AC power voltage is too low or cannot be used.	Defective Circuit Breaker (Protector)?	Replace Circuit Breaker (Protector).
	Layer Short-Circuit, Broken Wires In Armature Winding?	Repair or Replace Armature.

TROUBLESHOOTING (ENGINE AND GENERATOR)

Table 9. Engine and Generator Troubleshooting (Continued)

SYMPTOM	POSSIBLE PROBLEM	SOLUTION
Engine starts and "Idle Control Switch" is in OFF position. Engine speed rises and battery discharges too soon.	Defective Engine Regulator?	Replace Regulator.
	Defective Wiring?	Repair or Replace Wiring.
Engine starts and "Idle Control Switch" is in OFF position. Engine speed rises and engine seems overloaded.	Defective Alternator?	Repair or Replace Alternator.
	Damaged Alternator Bearing?	Replace Alternator Bearings.
Engine starts and "Idle Control Switch" is in OFF position. Engine speed rises and engine has large vibrations. overload.	Bad Engine Installation?	Repeat Installation of of Engine.
Engine starts and "Idle Control Switch" is in OFF position. Engine speed rises and engine has abnormal noise.	Loose Engine Parts?	Check All Engine Parts For Tightnes.
	Defective Alternator?	Check Alternator for Damaged Bearing or Loose Clamping Bolts.
	Defective Enclosure?	Check Enclosure Bolts for Tightness.
Engine starts and "Idle Control Switch" is in OFF position. Engine speed rises and remains at high speed when Idle Control switch is placed in the ON position.	Defective Idle Control Device?	Repair or Replace Idle Control Device.
	Defective Idle Control Switch?	Replace Idle Control Switch.
	Defective Solenoid?	Replace Solenoid.
	Defective Relay?	Replace Relay.

TROUBLESHOOTING (ENGINE)

Table 10. Engine Troubleshooting

SYMPTOM	POSSIBLE PROBLEM	SOLUTION
Engine does not start.	No fuel?	Replenish fuel.
	Air in the fuel system?	Bleed system.
	Water in the fuel system?	Remove water from fuel tank.
	Fuel pipe clogged?	Clean fuel pipe.
	Fuel filter clogged?	Clean or change fuel filter.
	Excessively high viscosity of fuel or engine oil at low temperature?	Use the specified fuel or engine oil.
	Fuel with low cetane number?	Use the specified fuel.
	Fuel leak due to loose injection pipe retaining nut?	Tighten nut.
	Incorrect injection timing?	Adjust.
	Fuel cam shaft worn?	Replace.
	Injection nozzle clogged?	Clean injection nozzle.
	Injection pump malfunctioning?	Repair or replace.
	Seizure of crankshaft, camshaft, piston, cylinder liner or bearing?	Repair or replace.
	Compression leak from cylinder?	Replace head gasket, tighten cylinder head bolt, glow plug and nozzle holder.
	Improper valve timing?	Correct or replace timing gear.
Piston ring and liner worn?	Replace.	
Excessive valve clearance?	Adjust.	
Starter does not run.	Battery discharged?	Charge battery.
	Starter malfunctioning?	Repair or replace.
	Key switch malfunctioning?	Repair or replace.
	Wiring disconnected?	Connect wiring.

TROUBLESHOOTING (ENGINE)

Table 10. Engine Troubleshooting (Continued)

SYMPTOM	POSSIBLE PROBLEM	SOLUTION
Engine revolution is not smooth	Fuel filter clogged or dirty?	Clean or change.
	Air cleaner clogged?	Clean or change.
	Fuel leak due to loose injection pipe retaining nut?	Tighten nut.
	Injection pump malfunctioning?	Repair or replace.
	Incorrect nozzle opening pressure?	Adjust.
	Injection nozzle stuck or clogged?	Repair or replace.
	Fuel over flow pipe clogged?	Clean.
	Governor malfunctioning?	Repair.
Either white or blue exhaust gas is observed.	Excessive engine oil?	Reduce to the specified level.
	Piston ring and liner worn or stuck?	Repair or replace.
	Incorrect injection timing?	Adjust.
	Deficient compression?	Adjust top clearance.
Either black or dark gray exhaust gas is observed.	Overload?	Lessen the load.
	Low grade fuel used?	Use the specified fuel.
	Fuel filter clogged?	Clean or change.
	Air cleaner clogged?	Clean or change.
	Deficient nozzle injection?	Repair or replace the nozzle.
Deficient output.	Incorrect injection timing?	Adjust.
	Engine's moving parts seem to be seizing?	Repair or replace.
	Uneven fuel injection?	Repair or replace the injection pump.
	Deficient nozzle injection?	Repair or replace the nozzle.
	Compression leak?	Replace head gasket, tighten cylinder head bolt, glow plug and nozzle holder.

EXPLANATION OF CODE IN REMARKS COLUMN

The following section explains the different symbols and remarks used in the Parts section of this manual. Use the help numbers found on the back page of the manual if there are any questions.

NOTICE

The contents and part numbers listed in the parts section are subject to change **without notice**. Multiquip does not guarantee the availability of the parts listed.

SAMPLE PARTS LIST

NO.	PART NO.	PART NAME	QTY.	REMARKS
1	12345	BOLT	1	INCLUDES ITEMS W/%
2%		WASHER, 1/4 IN.		NOT SOLD SEPARATELY
2%	12347	WASHER, 3/8 IN. ...	1	MQ-45T ONLY
3	12348	HOSE	A/R	MAKE LOCALLY
4	12349	BEARING	1	S/N 2345B AND ABOVE

NO. Column

Unique Symbols — All items with same unique symbol

(@, #, +, %, or >) in the number column belong to the same assembly or kit, which is indicated by a note in the “Remarks” column.

Duplicate Item Numbers — Duplicate numbers indicate multiple part numbers, which are in effect for the same general item, such as different size saw blade guards in use or a part that has been updated on newer versions of the same machine.

NOTICE

When ordering a part that has more than one item number listed, check the remarks column for help in determining the proper part to order.

PART NO. Column

Numbers Used — Part numbers can be indicated by a number, a blank entry, or TBD.

TBD (To Be Determined) is generally used to show a part that has not been assigned a formal part number at the time of publication.

A blank entry generally indicates that the item is not sold separately or is not sold by Multiquip. Other entries will be clarified in the “Remarks” Column.

QTY. Column

Numbers Used — Item quantity can be indicated by a number, a blank entry, or A/R.

A/R (As Required) is generally used for hoses or other parts that are sold in bulk and cut to length.

A blank entry generally indicates that the item is not sold separately. Other entries will be clarified in the “Remarks” Column.

REMARKS Column

Some of the most common notes found in the “Remarks” Column are listed below. Other additional notes needed to describe the item can also be shown.

Assembly/Kit — All items on the parts list with the same unique symbol will be included when this item is purchased.

Indicated by:

“INCLUDES ITEMS W/(unique symbol)”

Serial Number Break — Used to list an effective serial number range where a particular part is used.

Indicated by:

“S/N XXXXX AND BELOW”

“S/N XXXX AND ABOVE”

“S/N XXXX TO S/N XXX”

Specific Model Number Use — Indicates that the part is used only with the specific model number or model number variant listed. It can also be used to show a part is NOT used on a specific model or model number variant.

Indicated by:

“XXXXX ONLY”

“NOT USED ON XXXX”

“Make/Obtain Locally” — Indicates that the part can be purchased at any hardware shop or made out of available items. Examples include battery cables, shims, and certain washers and nuts.

“Not Sold Separately” — Indicates that an item cannot be purchased as a separate item and is either part of an assembly/kit that can be purchased, or is not available for sale through Multiquip.

SUGGESTED SPARE PARTS

DA7000 SERIES GENERATORS WITH KUBOTA Z482-EB/Z482-E2B/ Z482-E3B DIESEL ENGINES

1 to 3 units

Qty.	P/N	Description
5.....	1556211010.....	AIR FILTER
5.....	7000011221.....	AIR FILTER, ELEMENT
5.....	1523143560.....	FUEL FILTER
5.....	7000015241.....	OIL FILTER CARTRIDGE, Z482-EB/Z482-E2B ENGINES
5.....	1585332435.....	OIL FILTER, CARTRIDGE, Z482-E3B ENGINE
2.....	1980572531.....	FAN BELT
1.....	3741059110.....	STARTER SWITCH
5.....	3741055150.....	IGNITION KEY
1.....	1584139010.....	OIL SENDING UNIT, Z482-EB ENGINE
1.....	1584139013.....	OIL SENDING UNIT, Z482-E2B/Z482-E3B ENGINES
1.....	D2312500103.....	RADIATOR HOSE (UPPER)
1.....	D2312500003.....	RADIATOR HOSE (LOWER)
1.....	0810105800.....	FUEL CAP
1.....	0601842463.....	RESISTOR
1.....	0602201378.....	REGULATOR
1.....	0601807456.....	CIRCUIT BREAKER
1.....	0601827350.....	CONTROL UNIT
2.....	0601810830.....	BULB, INDICATOR ASSY.
3.....	0601806640.....	FUSE, 65 AMP
4.....	1685165510.....	GLOW PLUG, Z482-EB ENGINE
4.....	1685165512.....	GLOW PLUG, Z482-E2B/Z482-E3B ENGINES
2.....	1554383040.....	SWITCH, WATER TEMP., Z482-EB ENGINE
2.....	1753883040.....	SWITCH, WATER TEMP., Z482-E2B/Z482-E3B ENGINES

NOTICE

Part numbers on this Suggested Spare Parts list may supersede/replace the part numbers shown in the following parts lists.

NAMEPLATE AND DECALS ASSY.

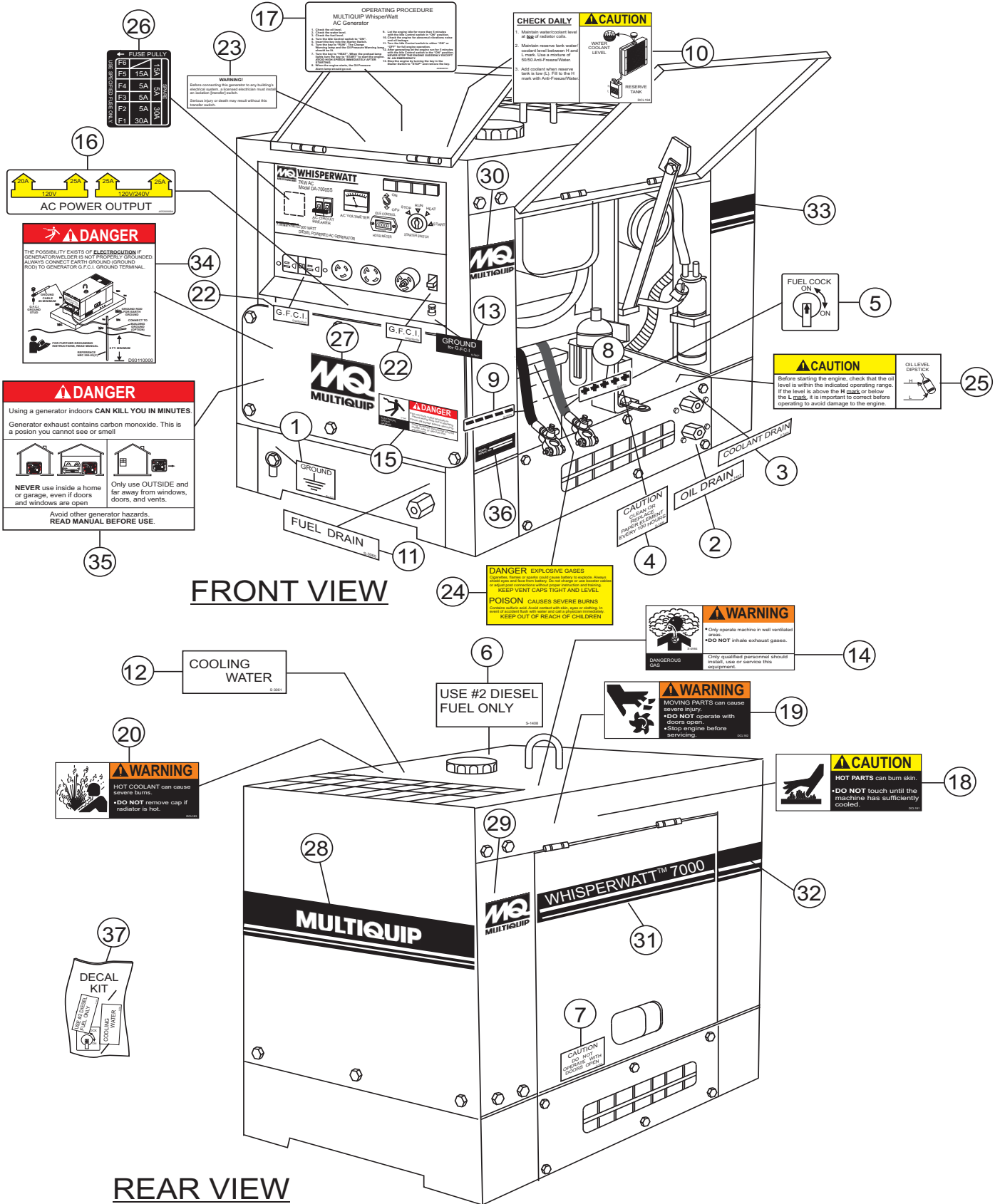

NAMEPLATE AND DECALS ASSY.

<u>NO.</u>	<u>PART NO.</u>	<u>PART NAME</u>	<u>QTY.</u>	<u>REMARKS</u>
1	0800628504	DECAL: GROUND	1.....	S1123
2#	1630645004	DECAL: OIL DRAIN	1.....	S1403
3#	1630647004	DECAL: COOLANT DRAIN.....	1.....	S1404
4#	1630610404	DECAL: CAUTION (PAPER ELEMENT).....	1.....	S1406
5#	1630680104	DECAL: FUEL COCK.....	1.....	S1407
6#	1630680004	DECAL: USE 2 DIESEL FUEL ONLY	1.....	S1408
6#	B9504501204	DECAL: DIESEL FUEL	1.....	B90450120 — DA7000SSA
7#	1630610504	DECAL: CAUTION (DOORS OPEN)	2.....	S1409
8#	0600689404	DECAL: BATTERY POSITIVE	1.....	S2090
9#	0800689504	DECAL: BATTERY NEGATIVE	1.....	S2091
10#	6390671104	DECAL: IMPORTANT CHECK DAILY	1.....	S2377
11#	7810680104	DECAL: FUEL DRAIN.....	1.....	S3060
12#	7810680204	DECAL: COOLING WATER	1.....	S3061
13#	8700611603	DECAL: GROUND FOR G. F. C. I.	1.....	S3821REPLACESP/N7670624004
14#	8700611804	DECAL: WARNING DANGEROUS GAS	1.....	S4984
15#	8700611904	DECAL: DANGER ELECT. SHOCK HAZ.....	1.....	S4985
16#	A5552000003	DECAL: AC POWER OUTPUT	1.....	A55200000
16#	A5552000013	DECAL: AC POWER OUTPUT	1.....	A55200001 — DA7000SSA
17#	A5552000103	DECAL: OPERATING PROCEDURE	1.....	A55200010
17#	A5552000113	DECAL: OPERATING PROCEDURE	1.....	A55200011 — DA7000SSA
18#	B9504000304	DECAL: CAUTION HOT PARTS	1.....	B90400030
19#	B9504000404	DECAL: WARNING MOVING PARTS	2.....	B90400040
20#	B9504100104	DECAL: WARNING HOT COOLANT	1.....	B90410010
21#	B9504500004	DECAL: WARNING DIESEL FUEL	1.....	B90450000
22#	7670624004	DECAL: G. F. C. I.....	2.....	D92200100
22#	D9522001004	DECAL: G. F. C. I.....	2.....	D92200100 — DA7000SSA
23#	0820610404	DECAL: WARNING (TRANSFER SWITCH)	1	
24#	0820650604	DECAL: DANGER EXPLO GASES (BATT.)	1	
25#	8700611524	DECAL: CAUTION OIL LEVEL GAUGE	1	
25#	B9505000304	DECAL: CAUTION OIL LEVEL GAUGE	1.....	B90500030 — DA7000SSA
26#	8700625504	DECAL: FUSE BOX	1	
27#	A556200004	DECAL: MQ	1.....	A56200000
28#	A5562100003	DECAL: STRIPE MULTIQUIP	1.....	A56210000
29#	A5562100104	DECAL: STRIPE MQ	1.....	A56210010
30#	A5562100204	DECAL: STRIPE MQ	1.....	A56210020
31#	A5562100303	DECAL: STRIPE WHISPERWATT	2.....	A56210030
32#	A5562100404	DECAL: STRIPE	1.....	A56210040
33#	A5562100504	DECAL: STRIPE	1.....	A56210050
34	D9531100004	DECAL: DANGER GROUNDING.....	1.....	D93110000
35	A9504000014	DECAL: DANGER HAZARDOUS FUMES.....	1.....	A90400001
36		PLATE, SERIAL NO.....	1.....	CONTACT MQ PARTS DEPT. WITH MODEL AND S/N
37	DCLDA7000SS	KIT, DECAL.....	1.....	INCLUDES ITEMS W/#

GENERATOR ASSY.

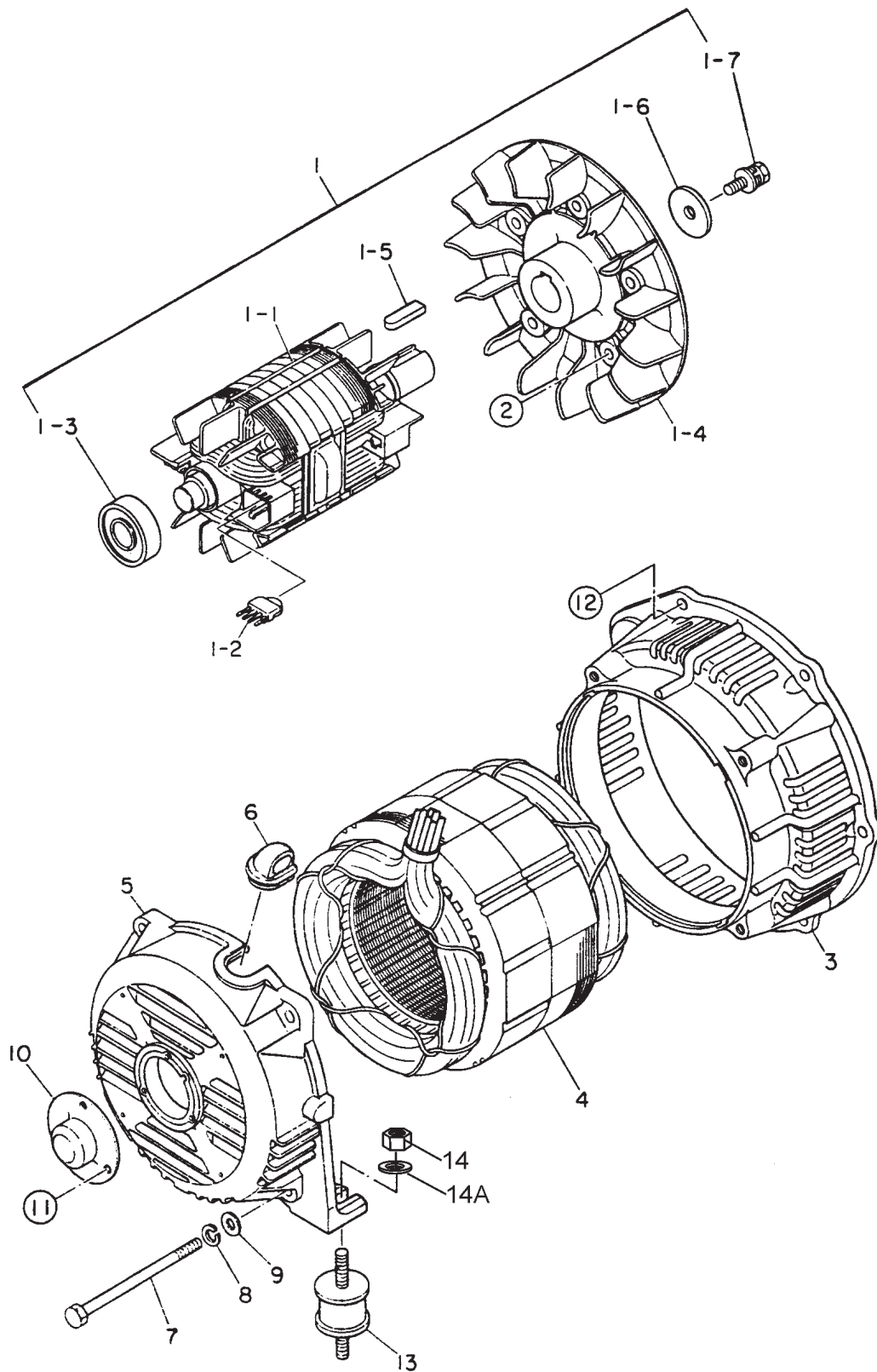

GENERATOR ASSY.

<u>NO.</u>	<u>PART NO.</u>	<u>PART NAME</u>	<u>QTY.</u>	<u>REMARKS</u>
1	A5110100003	ROTOR ASSY.	1.....	INCLUDES ITEMS W/#
1-1#	A5116000103	FIELD ASSY.	1	
1-2#	7871025004	RECTIFIER ASSY.	2	
1-3#	042006304	BEARING 6304 DOU.....	1.....	REPLACES 0071206304
1-4#	A5113100002	FAN	1	
1-5#	0171707033	KEY	1	
1-6#	1991072004	SET WASHER FAN	1	
1-7#	0012308020	HEX HEAD BOLT	1	
2	011208025	HEX HEAD BOLT.....	5.....	REPLACES 0012308025
3	A515510002	END BRACKET	1	
4	A5136000103	ARMATURE ASSY.	1	
5	A6155000002C	END BRACKET	1.....	REPLACES A6155000002
6	7871329514	GROMMET	1	
7	7901316004	SET BOLT	4	
8	0040008000	WASHER, LOCK	4	
9	031108160	WASHER, FLAT	4.....	REPLACES 0041206000
10	A6155400104C	COVER	1.....	REPLACES A6155400104
11	0027106012	MACHINE SCREW	3	
11	0027105012	MACHINE SCREW	3.....	DA7000SSA
12	0012308020	HEX HEAD BOLT	6	
13	0805084704	RUBBER SUSPENSION	2	
14	020108060	HEX NUT	2.....	REPLACES 0207006000
14A	0801086104	WASHER, FLAT	2	

CONTROL PANEL ASSY.

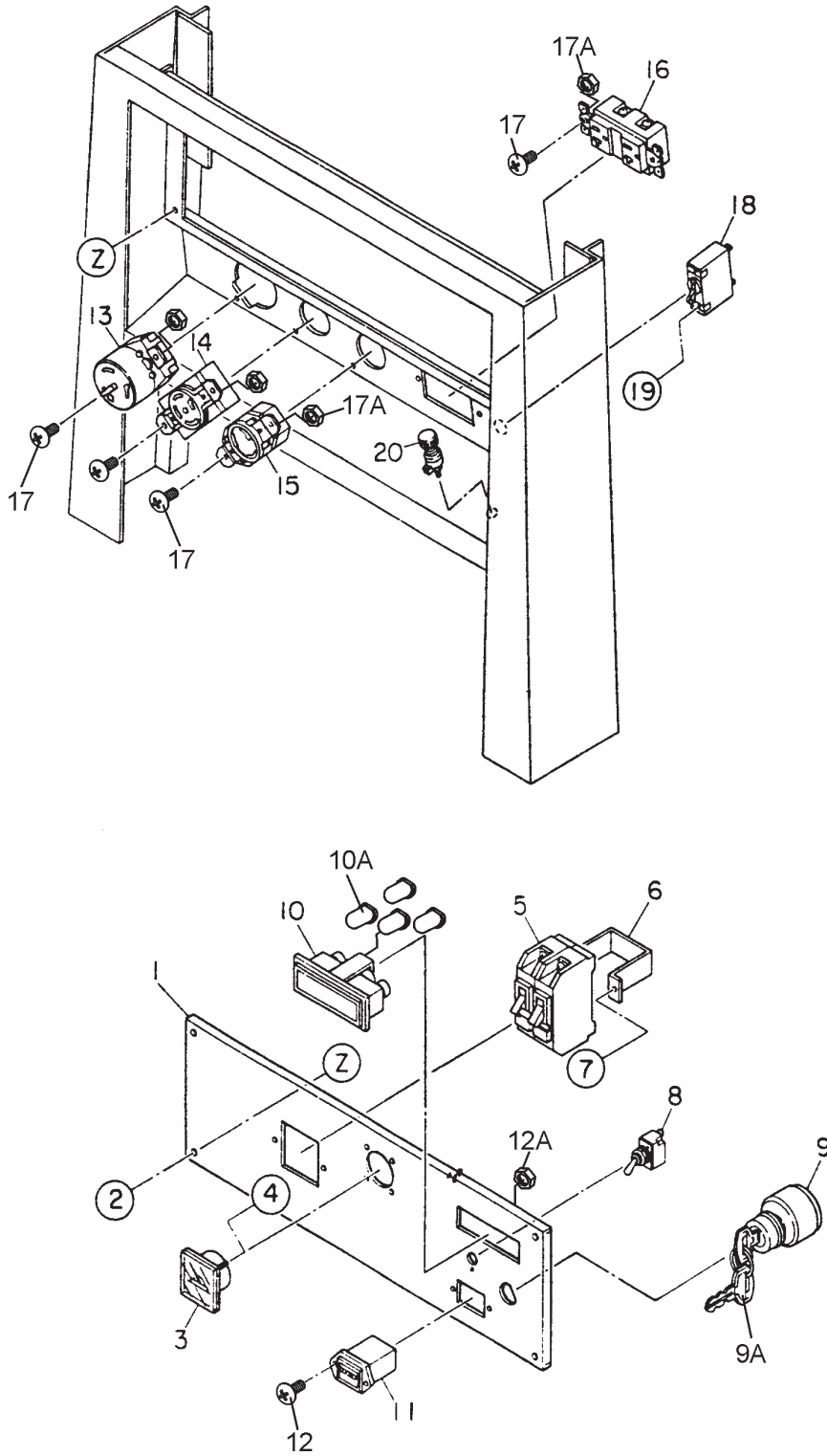

CONTROL PANEL ASSY.

<u>NO.</u>	<u>PART NO.</u>	<u>PART NAME</u>	<u>QTY.</u>	<u>REMARKS</u>
1	A5225000303	CONTROL PANEL	1	
1	A5511302402	CONTROL PANEL	1	DA7000SSA
2	0021805020	MACHINE SCREW	4	
3	0601800258	AC VOLTMETER, 120/240	1	
4	0207003000	HEX NUT	2	
5	0601807456	CIRCUIT BREAKER, KM52 265V 25A	1	
6	4341817004	BRACKET CIRCUIT BREAKER	1	
7	0021004016	MACHINE SCREW	2	
8	0601830771	IDLE CONTROL SWITCH	1	
9	1628663602	STARTER SWITCH	1	REPLACES 0602100077
9A	3741055150	IGNITION, KEY		
10	0601810523	INDICATOR ASSY.	1	
10A	0601810830	BULB	4	
11	0601800682	HOUR METER 820114	1	
12	0027403512	MACHINE SCREW	2	
12A	0030003500	HEX NUT	2	
13	0601811034	RECEPTACLE CS6369 125 250V 50A.....	1	REPLACES 0601812566
14	0601812529	RECEPTACLE, L14- 30R 125V 30A	1	
15	0601811031	RECEPTACLE, L5-30R 125V 30A.....	1	REPLACES 0601811035
16	0601812597	RECEPTACLE, 5-20R 120V 20A.....	1	REPLACES 0601812598
17	0021004010	MACHINE SCREW	8	
17A	0030004000	HEX NUT	8	REPLACES 0207004000
18	0601806420	CIRCUIT PROTECTOR, AC 250V 20A	1	
19	0027103005	MACHINE SCREW	2	
20	0601815109	GROUND TERMINAL	1	

ELECTRIC PARTS ASSY.

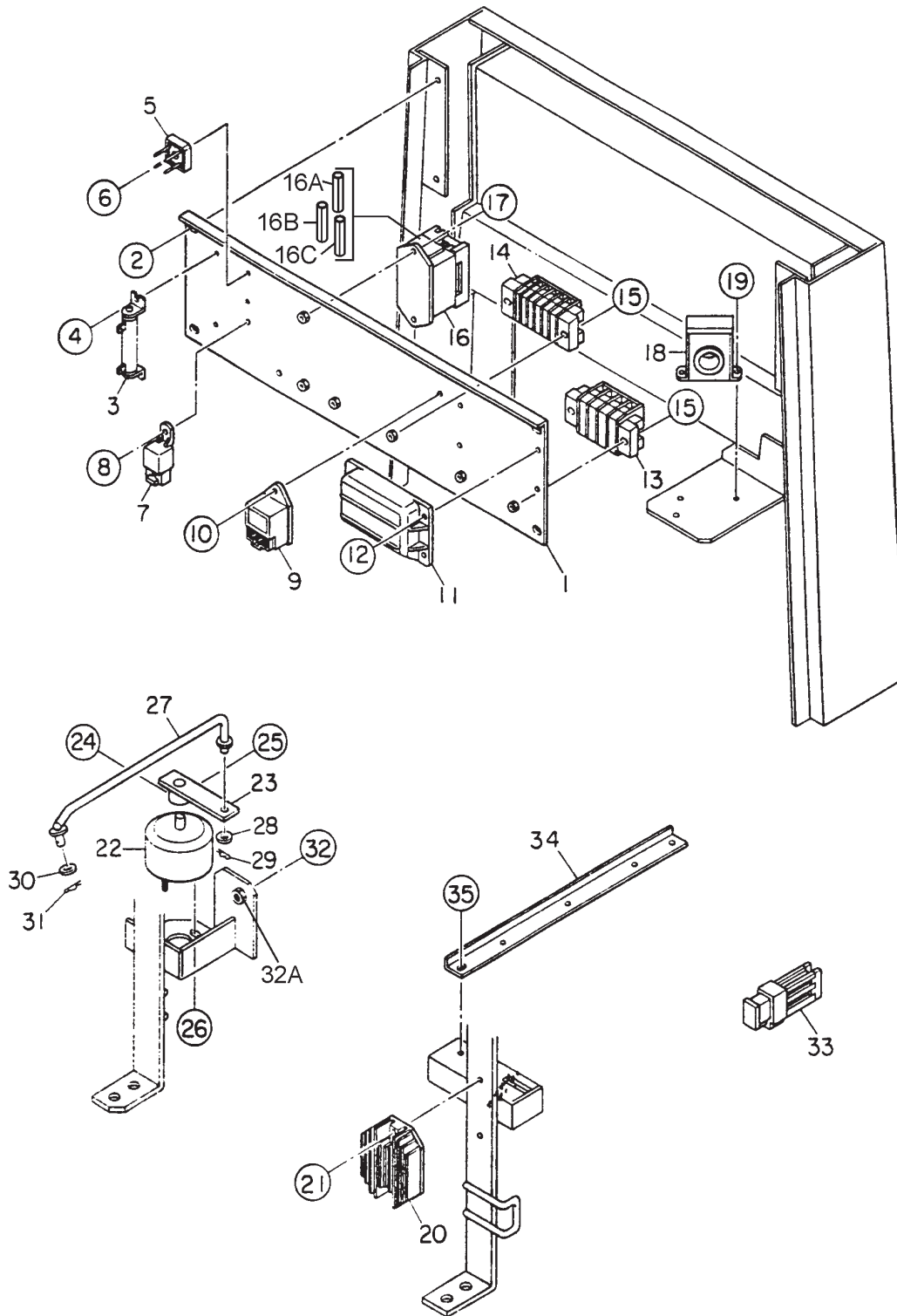

ELECTRIC PARTS ASSY.

<u>NO.</u>	<u>PART NO.</u>	<u>PART NAME</u>	<u>QTY.</u>	<u>REMARKS</u>
1	A5262500203	BRACKET ELECTRIC PARTS	1	
2	0016906016	HEX HEAD BOLT	4	
3	0601842463	RESISTOR, 30W 10 OHM	1	
4	0027104012	MACHINE SCREW	2	
5	0601823204	RECTIFIER, S5VB60	2	
6	0027103020	MACHINE SCREW	2	
7	0601823754	RELAY	1	
8	0027105016	MACHINE SCREW	1	
9	1569465990	LAMP TIMER	1	REPLACES 0602201273
10	0017105016	HEX HEAD BOLT	1	
11	1747260604	EMERGENCY UNIT	1	REPLACES 0602200475
12	0017105025	HEX HEAD BOLT	4	
13	0601815731	TERMINAL BOARD	1	
14	0601815759	TERMINAL BOARD	1	
15	0027105020	MACHINE SCREW	4	
16	8701899004	FUSE BOX	1	
16A	0601806642	FUSE, 5A	4	
16B	0601806643	FUSE, 15A	2	
16C	0601806644	FUSE, 30A	2	
17	0027105020	MACHINE SCREW	2	
18	0601827350	CONTROL UNIT	1	
19	0027104010	MACHINE SCREW	2	
20	1584464600	REGULATOR	1	REPLACES 1584464601
21	0017105025	HEX HEAD BOLT	2	
22	16226361032	ROTARY SOLENOID	1	REPLACES 1620150404
23	1992636004	ARM SOLENOID	1	
24	0050403020	SPRING PIN	1	
25	16226361032	HEX HEAD BOLT	1	REPLACES 0010106025
25A	0030006000	HEX NUT	1	REPLACES 0030006000
26	0207206000	HEX NUT	2	
27	D235630004	GOVERNOR ROD	1	
28	031108160	WASHER, FLAT	1	REPLACES 0041608000
29	0605010503	SNAP PIN	1	
30	0042806000	WASHER, FLAT	1	
31	505015300	SNAP PIN	1	REPLACES 0605010502
32	0010108050	HEX HEAD BOLT	1	
33A	020108060	HEX NUT	1	REPLACES 0207008000
33	0601806640	FUSE, 65A	1	
34	A5485500004	GUIDE	1	
35	0016906016	HEX HEAD BOLT	2	

ENGINE AND RADIATOR ASSY.

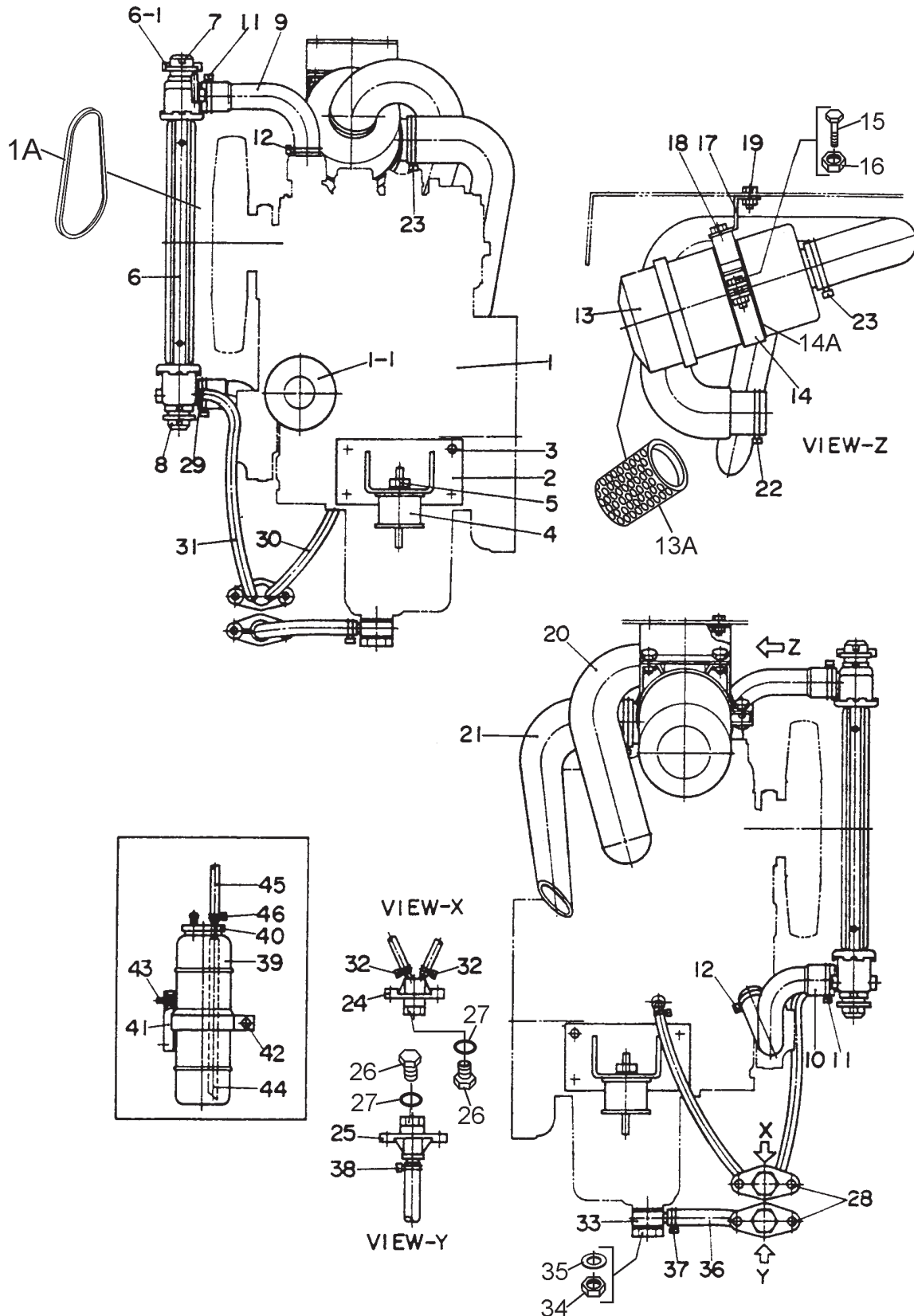

ENGINE AND RADIATOR ASSY.

NO.	PART NO.	PART NAME	QTY.	REMARKS
1	A5925200004	ENGINE, Z482EB	1DA7000SS
1	A5924200004	ENGINE, Z482E2BDGDE2	1DA7000SS
1	A5924200094	ENGINE, Z482E3BDGDE2	1DA7000SSA
1A	1980572531	FAN BELT	1REPLACES P/N 0602011477
1-1	7000015241	CARTRIDGE OIL FILTER	1REPLACES P/N's 1584132430 AND 0602041271
1-1	1585332435	CARTRIDGE OIL FILTER	1Z482-E3B ENGINE
2	8745112003	ENGINE FOOT	2	
3	0012410020	HEX HEAD BOLT	8	
4	7085419004	RUBBER SUSPENSION	2	
5	0207010000	HEX NUT	2	
6	0602012750	RADIATOR	1INCLUDES ITEM W/#
6	0602012795	RADIATOR	1INCLUDES ITEM W/% DA7000SSA
6-1#	0602011074	CAP RADIATOR	1	
6-1%	0602011079	CAP RADIATOR.....	1DA7000SSA
7	8702014004	INSULATOR	2DA7000SS-DA7000SSW ONLY
8	0605000460	RUBBER MOUNT	2	
9	D2312500103	RADIATOR HOSE	1	
10	D2312500003	RADIATOR HOSE	1	
11	0605515111	HOSE BAND, Ø34	2	
11	0605515134	HOSE BAND HS-16.....	2DA7000SSA
12	0605515003	HOSE BAND, Ø30	2	
13	1556211010	FILTER AIR CLEANER ASSY.	1REPLACES P/N 0602046265
13A	7000011221	ELEMENT AIR CLEANER	1REPLACES P/N's 0602046374, 1556211081
14	3415013960	BAND	1	
14A	0222600340	RUBBER CUSHION	1	
15	0016908030	HEX HEAD BOLT	1	
16	0207008000	HEX NUT	1	
17	8742031004	BRACKET AIR CLEANER	1	
18	0016908020	HEX HEAD BOLT	2	
19	0016906016	HEX HEAD BOLT	2	
20	8742032003	HOSE AIR CLEANER	1	
21	1612036203	HOSE AIR CLEANER	1	
22	0605515006	HOSE BAND, Ø50	1	
23	0605515021	HOSE BAND, Ø55	2	
24	1622014103	DRAIN JOINT WATER	1	
25	1502025103	DRAIN JOINT OIL	1	

NOTICE

For Tier II white units air cleaner assy., See Kubota engine section in this manual.

ENGINE AND RADIATOR ASSY.

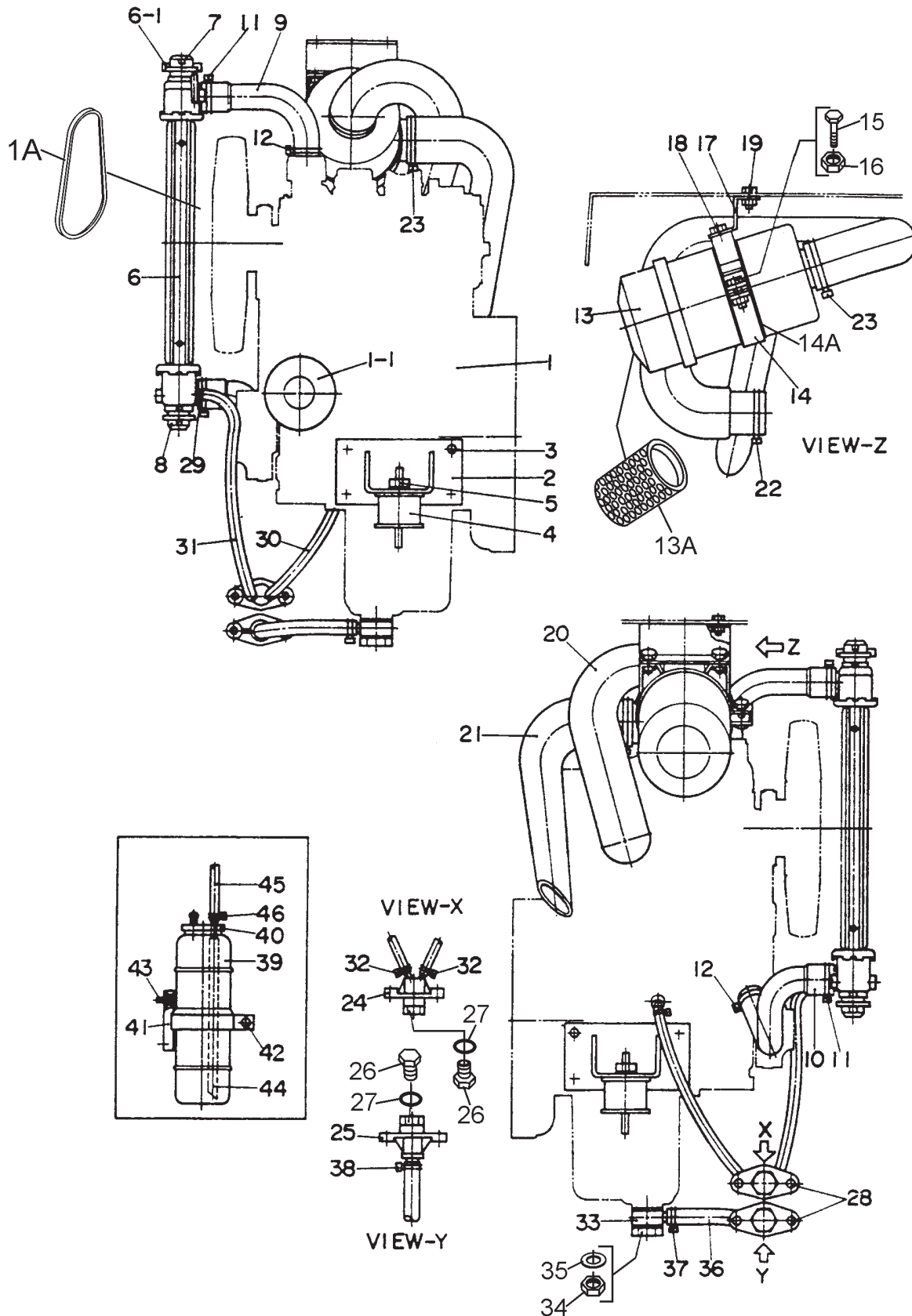

ENGINE AND RADIATOR ASSY.

<u>NO.</u>	<u>PART NO.</u>	<u>PART NAME</u>	<u>QTY.</u>	<u>REMARKS</u>
26	0802011104	PLUG	2	
27	0150000018	O-RING A P18	2	
28	0016906016	HEX HEAD BOLT	4	
29	D2322400004	HOSE JOINT	1	
30	0199900550	DRAIN HOSE	1	
31	0199900700	DRAIN HOSE	1	
31	0199900500	DRAIN HOSE.....	1.....	DA7000SSA
32	0605515094	HOSE BAND, Ø12	4	
33	0805010004	DRAIN JOINT	1	
34	1552053004	JOINT BOLT	1	
35	0602021190	PACKING SW22	2	
36	0192200400	DRAIN HOSE	1	
37	0605515081	HOSE BAND	1	
38	0605515003	HOSE BAND, Ø27	1	
38	0605515159	HOSE BAND, Ø32	1.....	DA7000SSA
39	0802081403	RESERVE TANK	1	
40	0602081104	CAP RESERVE TANK	1	
41	1622082104	BRACKET RESERVE TANK	1	
42	0016906025	HEX HEAD BOLT	1	
43	0016906016	HEX HEAD BOLT	2	
44	7222016304	HOSE	1	
45	0199900650	HOSE	1	
45	0199900650	HOSE.....	1.....	DA7000SSA
46	0605515094	HOSE BAND, Ø12	2	

NOTICE

For Tier II white units Air Cleaner Assy., See Kubota engine section in this manual.

BATTERY ASSY.

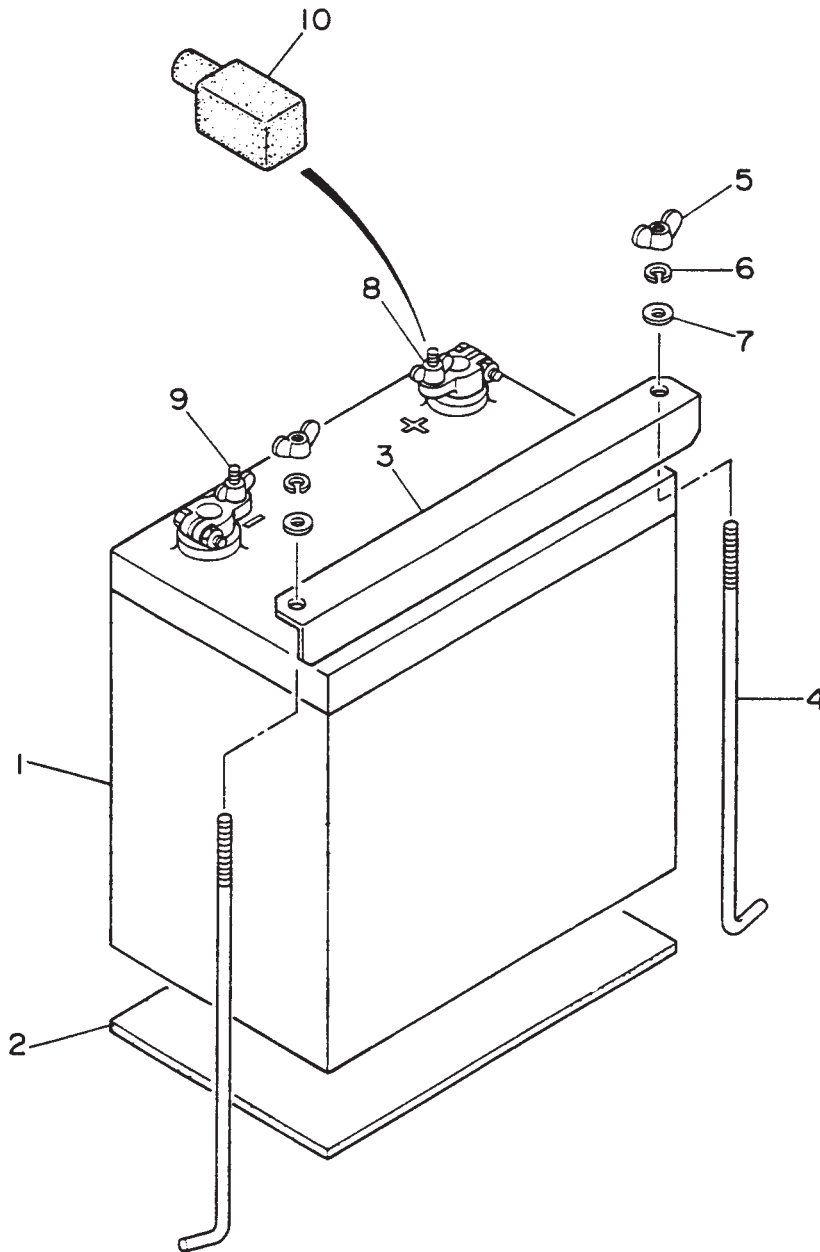

BATTERY ASSY.

<u>NO.</u>	<u>PART NO.</u>	<u>PART NAME</u>	<u>QTY.</u>	<u>REMARKS</u>
1	0167103820	BATTERY	1	
2	1702202104	BATTERY SHEET	1	
3	D2345200004	BATTERY BAND	1	
4	0805082704	BATTERY BOLT	2	
5	0037806000	WING NUT	2	
6	0040006000	WASHER, LOCK	2	
7	0041206000	WASHER, FLAT	2	
8	0602220310	TERMINAL ASSY. (POSITIVE)	1	
9	0602220311	TERMINAL ASSY. (NEGATIVE)	1	
10	0602220600	TERMINAL CAP	1	

MUFFLER ASSY.

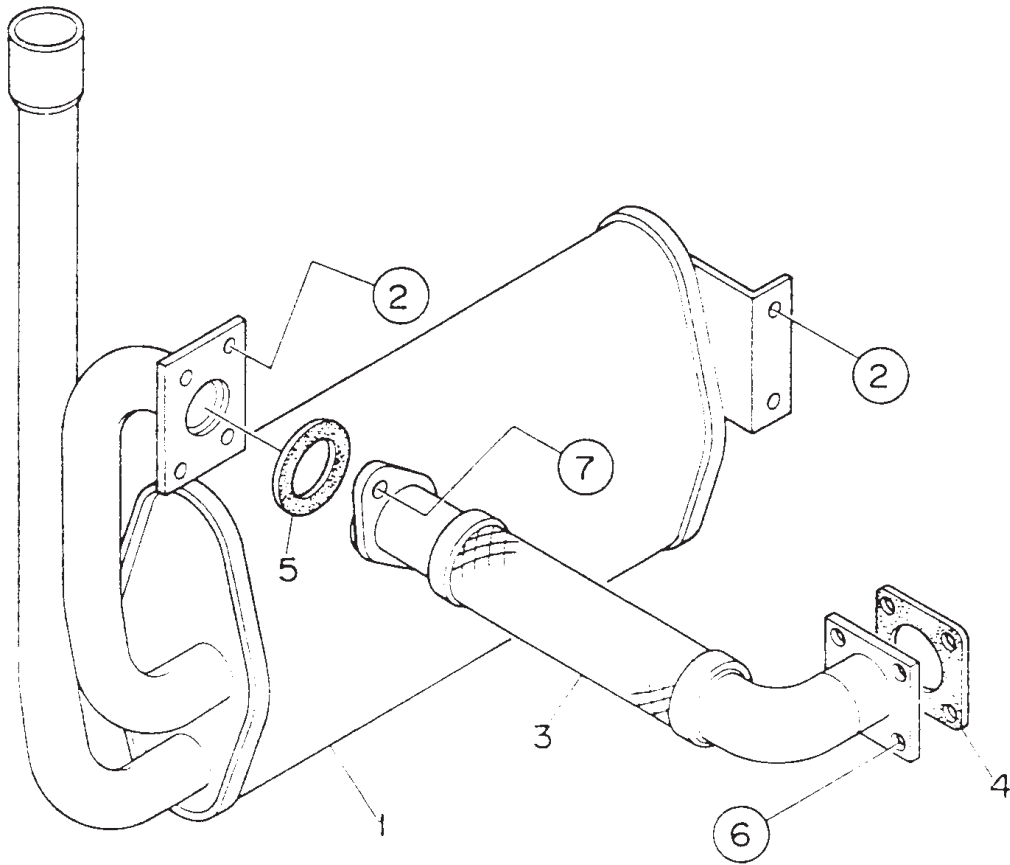

MUFFLER ASSY.

<u>NO.</u>	<u>PART NO.</u>	<u>PART NAME</u>	<u>QTY.</u>	<u>REMARKS</u>
1	D2332100003	MUFFLER	1	
2	0016908020	HEX. HEAD BOLT	4	
3	D2335000003	EXHAUST PIPE	1	
4	1526312371	GASKET	1.....	REPLACES 1526312371
5	1502336004	GASKET	1	
6	0207008000	HEX. NUT	4	
7	0016908035	HEX. HEAD BOLT	2	

FUEL TANK ASSY.

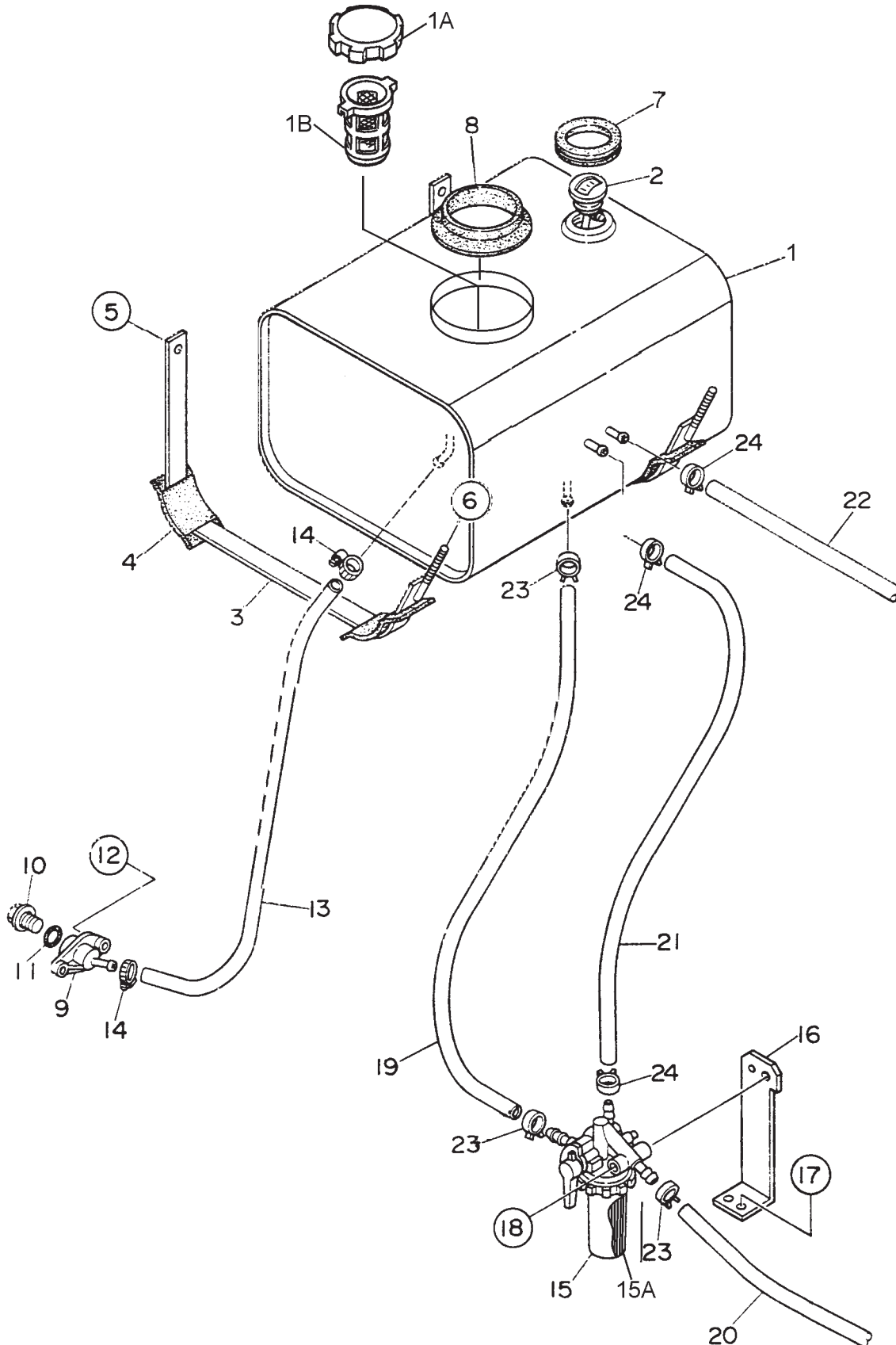

FUEL TANK ASSY.

<u>NO.</u>	<u>PART NO.</u>	<u>PART NAME</u>	<u>QTY.</u>	<u>REMARKS</u>
1	D2365000013	FUEL TANK	1	
1A	0810105800	CAP, FUEL TANK	1	
1B	0810105900	FUEL FILTER	1	
2	0602125033	FUEL GAUGE	1	
3	D2365200004	TANK BAND	2	
4	0805003414	PAD, TANK BANK	4	
5	0016906016	HEX. HEAD BOLT	2	
6	0207308000	HEX. NUT	2	
7	D1490600104	RUBBER SEAL	1	
8	1615511204	RUBBER SEAL	1	
8	B9312400004A	RUBBER SEAL.....	1.....	DA7000SSA
9	7812014003	DRAIN JOINT	1	
10	0802011104	PLUG	1	
11	0150000018	O-RING A P18	1	
12	0016906016	HEX. HEAD BOLT	2	
13	0199900670	DRAIN HOSE	1	
14	0605515094	HOSE BAND F-12	2	
15	1553143010	FUEL FILTER ASSY.....	1.....	REPLACES 0602042460 AND 1553143012
15A	1523143560	ELEMENT, FUEL FILTER.....	1.....	REPLACES 0602042171 AND 1523143563
16	D2368700004	BRACKET, FUEL FILTER	1	
17	0016906016	HEX. HEAD BOLT	2	
18	0016908065	HEX. HEAD BOLT	1	
19	0966180240	SUCTION HOSE.....	1.....	REPLACES 0605513158
20	0966180400	SUCTION HOSE.....	1.....	REPLACES 0605513101
21	0966140320	RETURN HOSE.....	1.....	REPLACES 0605514101
22	0966140240	RETURN HOSE.....	1.....	REPLACES 0605514102
23	1491142750	HOSE BAND.....	4.....	REPLACES 0605515070
24	1024442320	HOSE BAND.....	4.....	REPLACES 0605515072

OIL FILTER RETROFIT ASSY.

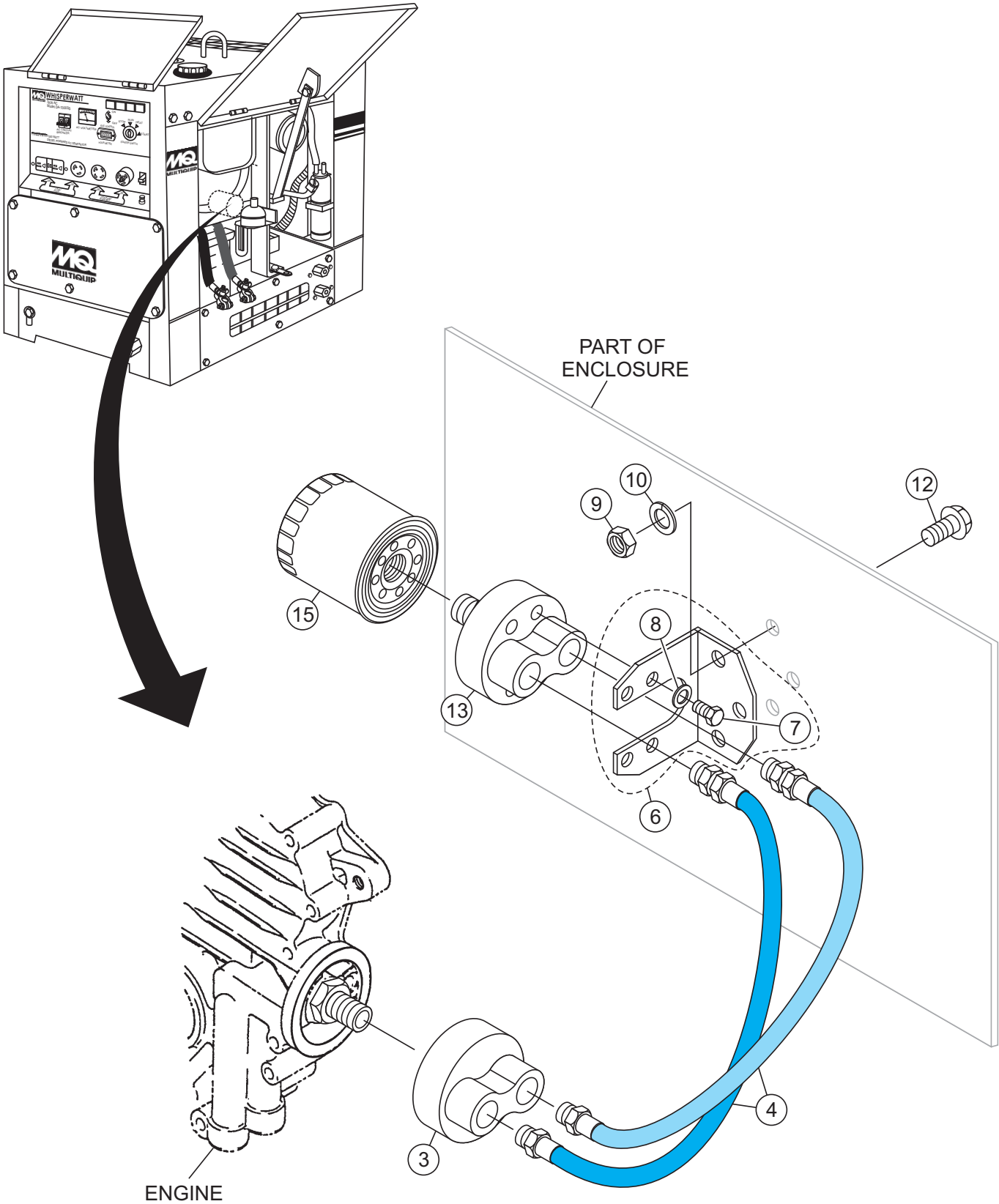

OIL FILTER RETROFIT ASSY.

<u>NO.</u>	<u>PART NO.</u>	<u>PART NAME</u>	<u>QTY.</u>	<u>REMARKS</u>
3	148002003	ADAPTER FILTER	1	
4	010601000	HOSE KIT	1	
6	149149001	BRACKET	1	INCLUDES ITEMS W/#
7#		BOLT	4	NOT SOLD SEPARATELY
8#		LOCKWASHER.....	4	NOT SOLD SEPARATELY
9	DA7000NUT	NUT	3	
10	DA7000LOCKWASHER	LOCKWASHER	3	
12	DA7000BOLT	BOLT	3	
13	149002000	FILTERHEAD	1	
15	7000015241	SPIN-ON OIL FILTER	1	

ENCLOSURE ASSY.

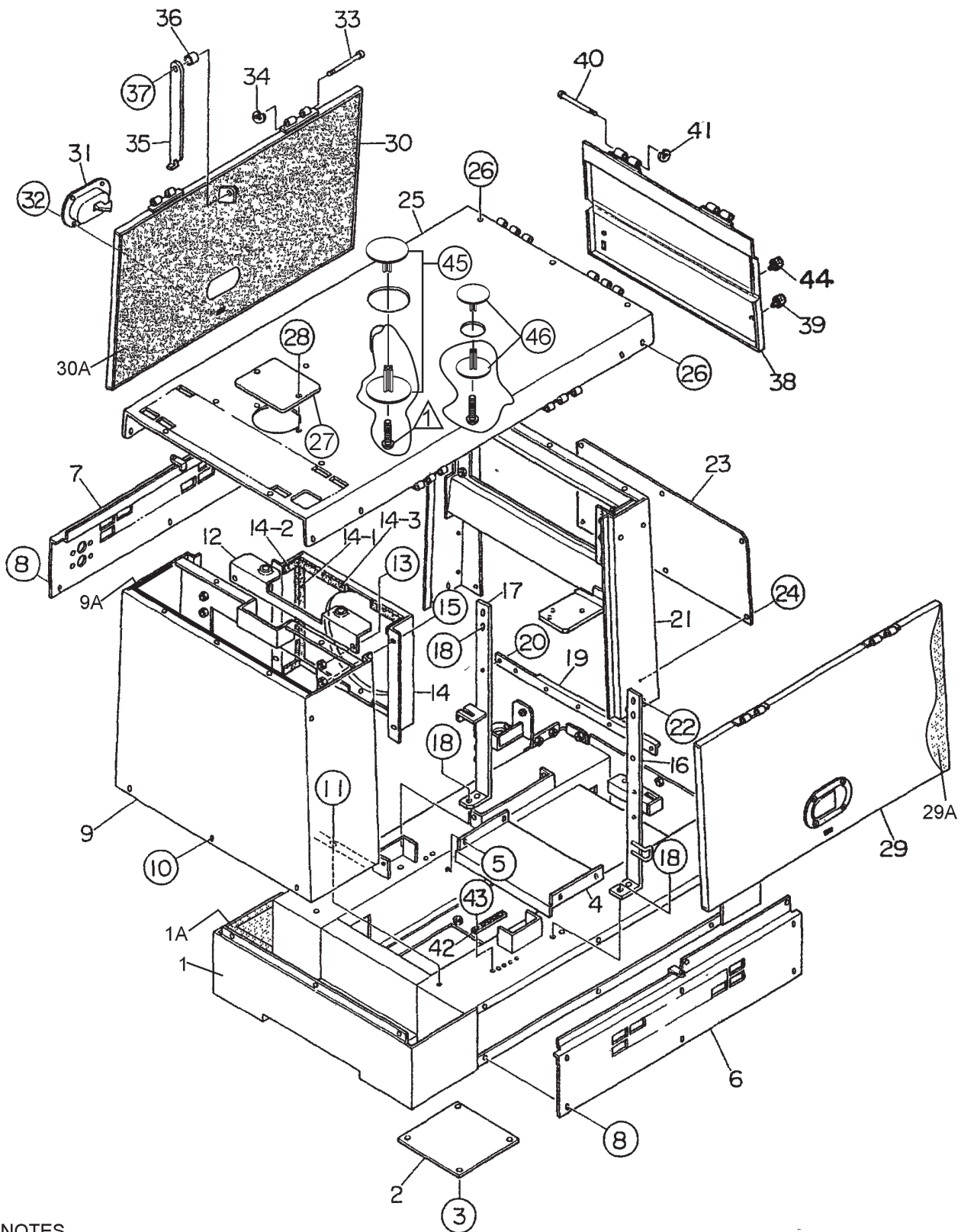

NOTES

- ▲ PURCHASE SHEET METAL SCREW
LOCALLY DA-7000SSGH WHITE UNITS ONLY.

ENCLOSURE ASSY.

NO.	PART NO.	PART NAME	QTY.	REMARKS
1	A5415000202	BASE	1	SEE ORDER CODE CHART BELOW
1A	D2492100004	LINING	1	
2	D2415100004	FLOOR PANEL	1	SEE ORDER CODE CHART BELOW
3	0016906016	HEX HEAD BOLT	4	
4	A5415600104	DUCT	1	SEE ORDER CODE CHART BELOW
5	0016906016	HEX HEAD BOLT	4	
6	D2455200113	SPLASHER PANEL	1	SEE ORDER CODE CHART BELOW
7	D2455200003A	SPLASHER PANEL	1	REPLACES P/N D2455200003 SEE ORDER CODE CHART BELOW
8	0016906016	HEX HEAD BOLT	12	
9	D2425000012B	FRONT FRAME, (ORANGE UNITS)	1	REPLACES P/N D2425000012 S/N 3757609 AND BELOW
9	D2425000022	FRONT FRAME, (WHITE UNITS)	1	S/N 3757610 AND ABOVE
9A	0220900340	RUBBER SEAL	2	
10	0016906016	HEX HEAD BOLT	3	
11	0016908020	HEX HEAD BOLT	2	
12	D2312100004	BRACKET RADIATOR	1	
13	0016906016	HEX HEAD BOLT	2	
14	D2312300013	FAN SHROUD	1	
14-1	D2492200004	LINING	1	
14-2	0221700050	LINING	4	
14-3	0221900165	LINING	4	
15	0016906016	HEX HEAD BOLT	4	
16	A5435300203	HANGER.....	1	SEE ORDER CODE CHART BELOW
17	A5435300403	HANGER.....	1	SEE ORDER CODE CHART BELOW
18	0012310025	HEX HEAD BOLT	8	
19	D2485500014	HARNESS GUIDE	1	
20	0016906016	HEX HEAD BOLT	2	
21	A5445000102	REAR FRAME, (ORANGE UNITS)	1	
21	A5445000112	REAR FRAME, (WHITE UNITS)	1	
22	0016906016	HEX HEAD BOLT	4	
23	D2445300004	COVER REAR FRAME.....	1	SEE ORDER CODE CHART BELOW
24	0016906016	HEX HEAD BOLT	6	

ORDER CODE CHART

THE PART NUMBER ABOVE INDICATES DEFAULT COLOR OF ORANGE. TO ORDER WITH DIFFERENT COLOR, PLEASE ADD THE FOLLOWING LETTERS WITH THE PART NUMBER:

MQW-WHITE

Unit serial number may be required

ENCLOSURE ASSY.

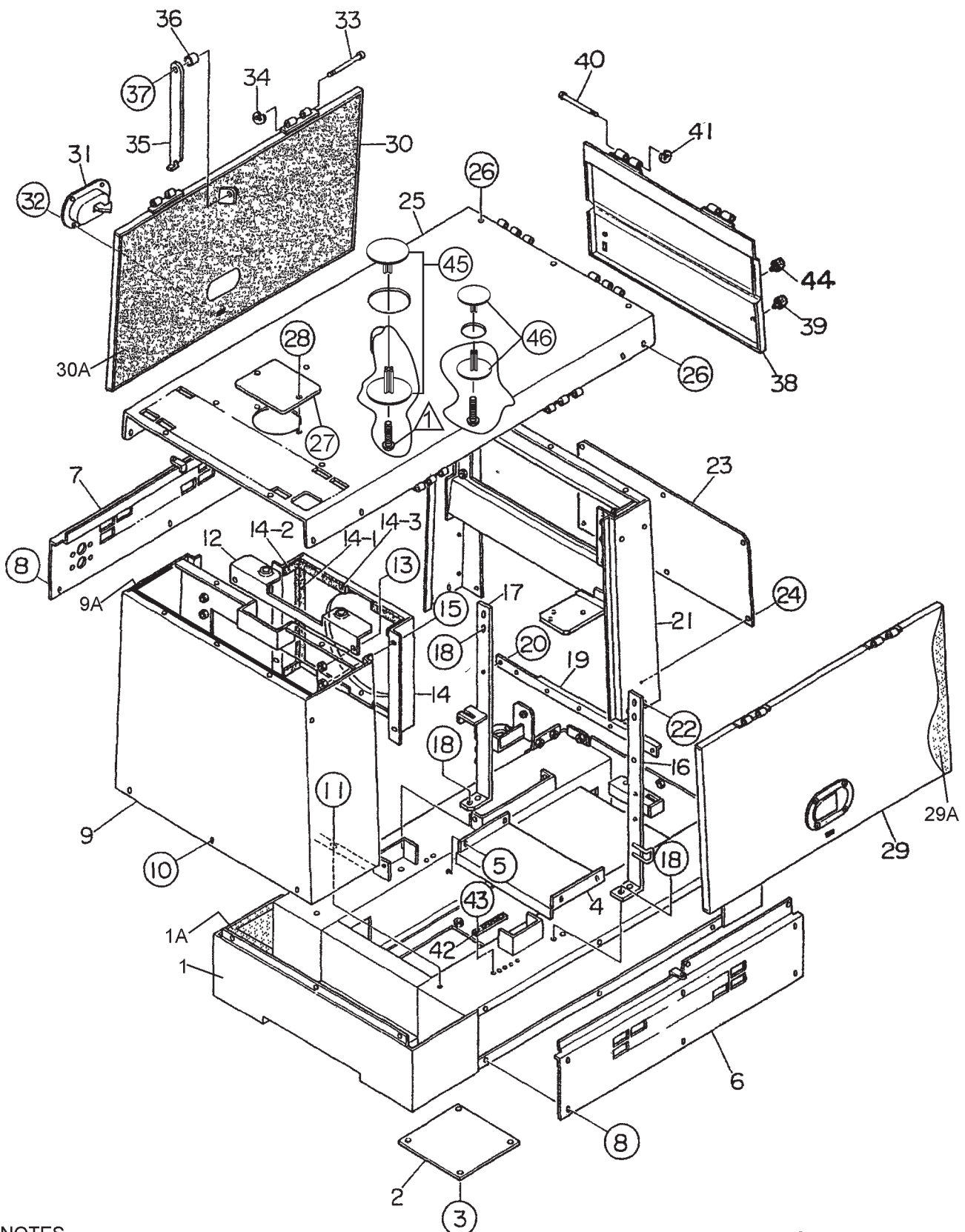

NOTES

ENCLOSURE ASSY.

<u>NO.</u>	<u>PART NO.</u>	<u>PART NAME</u>	<u>QTY.</u>	<u>REMARKS</u>
25	A5465000102	ROOF PANEL, (ORANGE UNITS)	1	
25	A5465000112	ROOF PANEL, (WHITE UNITS)	1	
26	0016906016	HEX HEAD BOLT	15	
27	8432081004	COVER RADIATOR CAP	1	SEE ORDER CODE CHART BELOW
28	0016906016	HEX HEAD BOLT	2	
29	D245500113	SIDE DOOR	1	
29A	A5495400704	LINING	1	
30	D2455000013	SIDE DOOR.....	1	SEE ORDER CODE CHART BELOW
30A	A5495400704	LINING, (ORANGE UNITS)	1	
30A	A5495400604	LINING, (WHITE UNITS)	1	
31	0605010215	DOOR HANDLE	2	
32	0021805016	MACHINE SCREW	8	
33	0810014704	PIN	4	
34	0080200004	SNAP RING	4	
35	D2455700004	DOOR STAY	2	
36	7835088004	COLLAR	2	
37	0016908020	HEX HEAD BOLT	2	
38	A5445200003	REAR DOOR, (ORANGE UNITS)	1	
38	A5445200013	REAR DOOR, (WHITE UNITS)	1	
39	0601851613	STOPPER	2	
40	0810014704	PIN	2	
41	0080200004	SNAP RING	2	
42	8511864604	TERMINAL PLATE	1	
43	0016906016	HEX HEAD BOLT	5	
44	0601851660	STOPPER	2	
45	97535K25	CAP, 4-INCH FUEL FILL.....	1	OPTION
46	97535K21	CAP, 3-INCH FUEL GAUGE	1	OPTION

ORDER CODE CHART

THE PART NUMBER ABOVE INDICATES DEFAULT COLOR OF ORANGE. TO ORDER WITH DIFFERENT COLOR, PLEASE ADD THE FOLLOWING LETTERS WITH THE PART NUMBER:

MQW-WHITE

Unit serial number may be required

RUBBER SEALS ASSY.

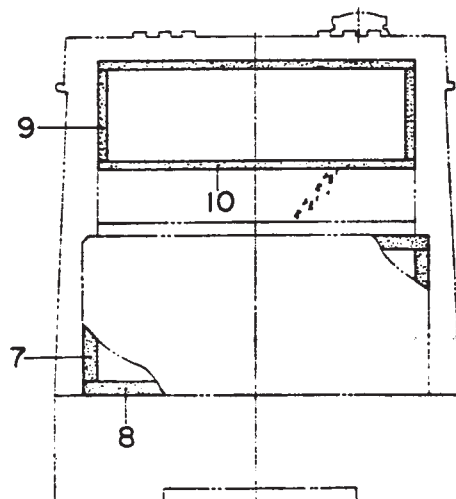
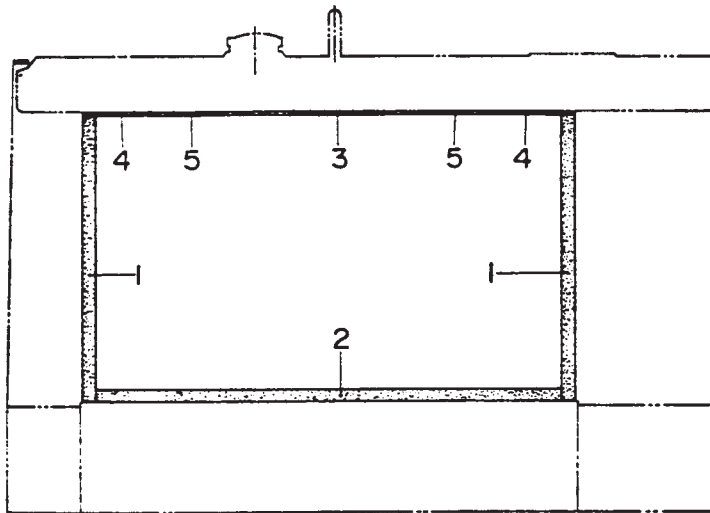
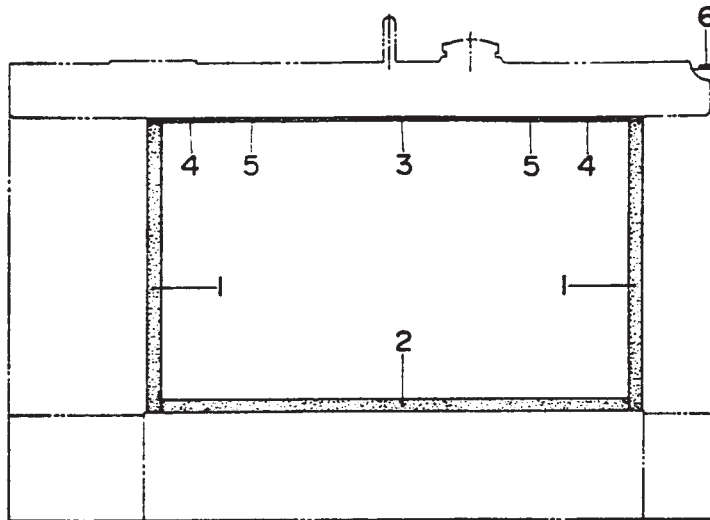

RUBBER SEALS ASSY.

<u>NO.</u>	<u>PART NO.</u>	<u>PART NAME</u>	<u>QTY.</u>	<u>REMARKS</u>
1	0229400470	RUBBER SEAL	4	
2	0229400760	RUBBER SEAL	2	
3	0222900325	RUBBER SEAL	2	
4	0222900125	RUBBER SEAL	4	
5	0222600100	RUBBER SEAL	4	
6	0228300600	RUBBER SEAL	1	
7	0228300200	RUBBER SEAL	2	
8	0228300550	RUBBER SEAL	2	
9	0227600130	RUBBER SEAL	2	
10	0227600500	RUBBER SEAL	2	

KUBOTA Z482-EB/E2B/E3B ENGINE — CRANKCASE ASSY.

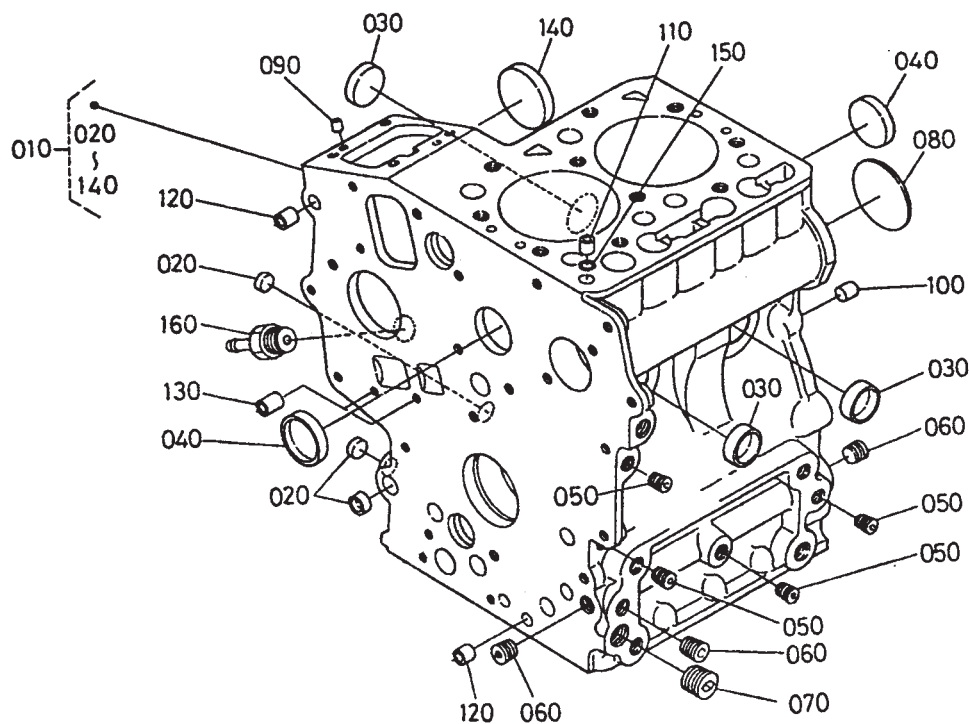

KUBOTA Z482-EB/E2B/E3B ENGINE — CRANKCASE ASSY.

CRANKCASE ASSY.

<u>NO.</u>	<u>PART NO.</u>	<u>PART NAME</u>	<u>QTY.</u>	<u>REMARKS</u>
010	1685301012	COMP. CRANKCASE, Z482-EB	1.....	INCLUDES ITEMS W/\$
010	1685301017	COMP. CRANKCASE, Z482-E2B	1.....	INCLUDES ITEMS W/#
010	1685301019	COMP. CRANKCASE, Z482-E3B	1.....	INCLUDES ITEMS W/%
020\$#%	1685196260	CAP, SEALING	3	
030\$#%	1685196270	CAP, SEALING	3	
040\$#%	1545196270	CAP, SEALING	2	
050\$#%	1526196010	PLUG	4	
060\$#%	1552196020	PLUG	1	
070\$#%	1552196030	PLUG	1	
080\$#%	1526196160	PLUG, EXPANSION	1	
090\$#%	0501200508	PIN, STRAIGHT	2	
100\$#%	0501200814	PIN, STRAIGHT	2	
110\$#%	1522133650	PIN, PIPE	1	
120\$#%	1523133960	PIN, PIPE	2	
130\$#%	1733159190	PIN, PIPE	2	
140\$#%	1685116212	COVER, FUEL CAMSHAFT	1	
150#	1522133700	O-RING	1.....	Z482-E2B ONLY
160\$#%	1584773130	JOINT, DRAIN PIPE	1	

KUBOTA Z482-EB/E2B/E3B ENGINE — OIL PUMP ASSY.

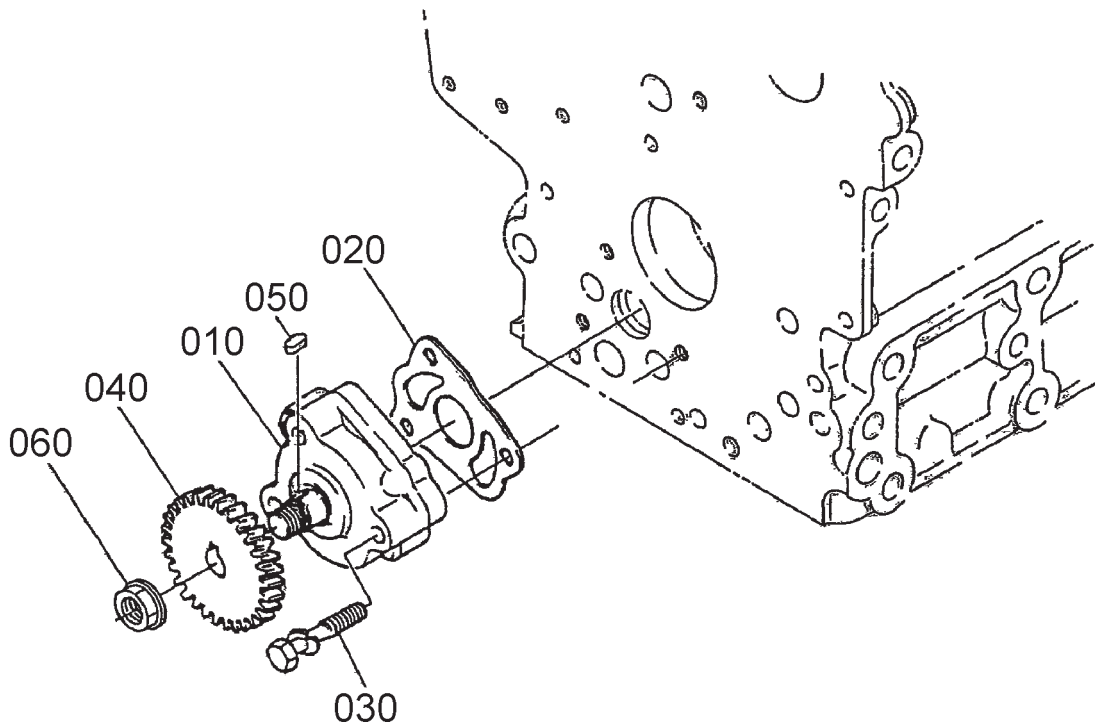

KUBOTA Z482-EB/E2B/E3B ENGINE — OIL PUMP ASSY.

OIL PUMP ASSY.

<u>NO.</u>	<u>PART NO.</u>	<u>PART NAME</u>	<u>QTY.</u>	<u>REMARKS</u>
010	1685135010	OIL PUMP ASSY.....	1.....	Z482-EB
010	1685135012	OIL PUMP ASSY.....	1.....	Z482-E2B AND Z482-E3B
020	1685135152	GASKET, OIL PUMP NA	1	
030	1584191050	BOLT	3	
040	1584135660	GEAR, OIL PUMP DRIVE	1	
050	0571200408	KEY, FEATHER	1	
060	0278350100	NUT, FLANGE	1	

KUBOTA Z482-EB/E2B/E3B ENGINE — OIL PAN ASSY.

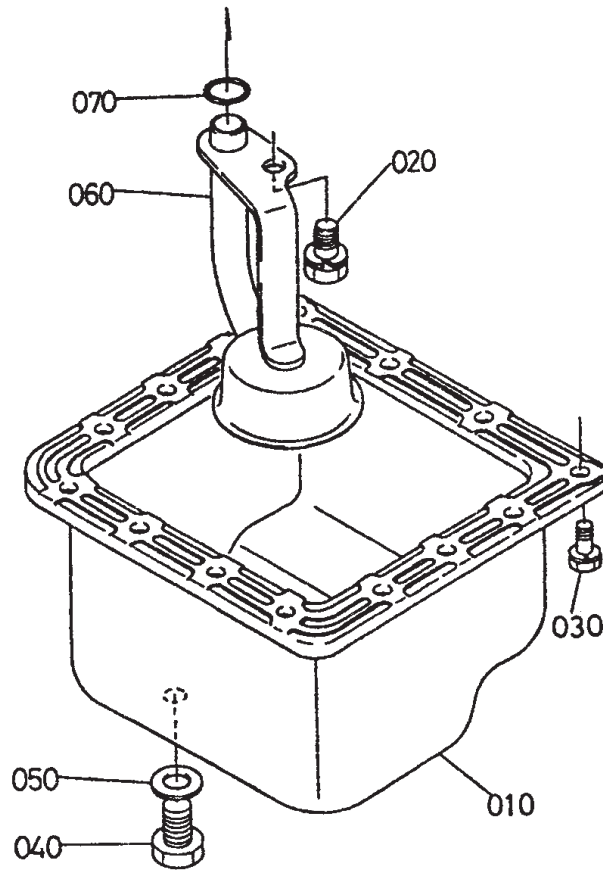

KUBOTA Z482-EB/E2B/E3B ENGINE — OIL PAN ASSY.

OIL PAN ASSY.

<u>NO.</u>	<u>PART NO.</u>	<u>PART NAME</u>	<u>QTY.</u>	<u>REMARKS</u>
010	1756101505	COMP. OIL PAN	1	
020	0112360814	BOLT	1	
030	0102350612	BOLT	14.....	Z482-EB AND Z482-E2B
030	0102350614	BOLT	14.....	Z482-E3B
040	1654133750	PLUG, DRAIN	1	
050	1545196670	GASKET	1	
060	1685132110	FILTER, OIL	1	
070	0481400160	O-RING	1	

KUBOTA Z482-EB/E2B/E3B ENG. — CYLINDER HEAD ASSY.

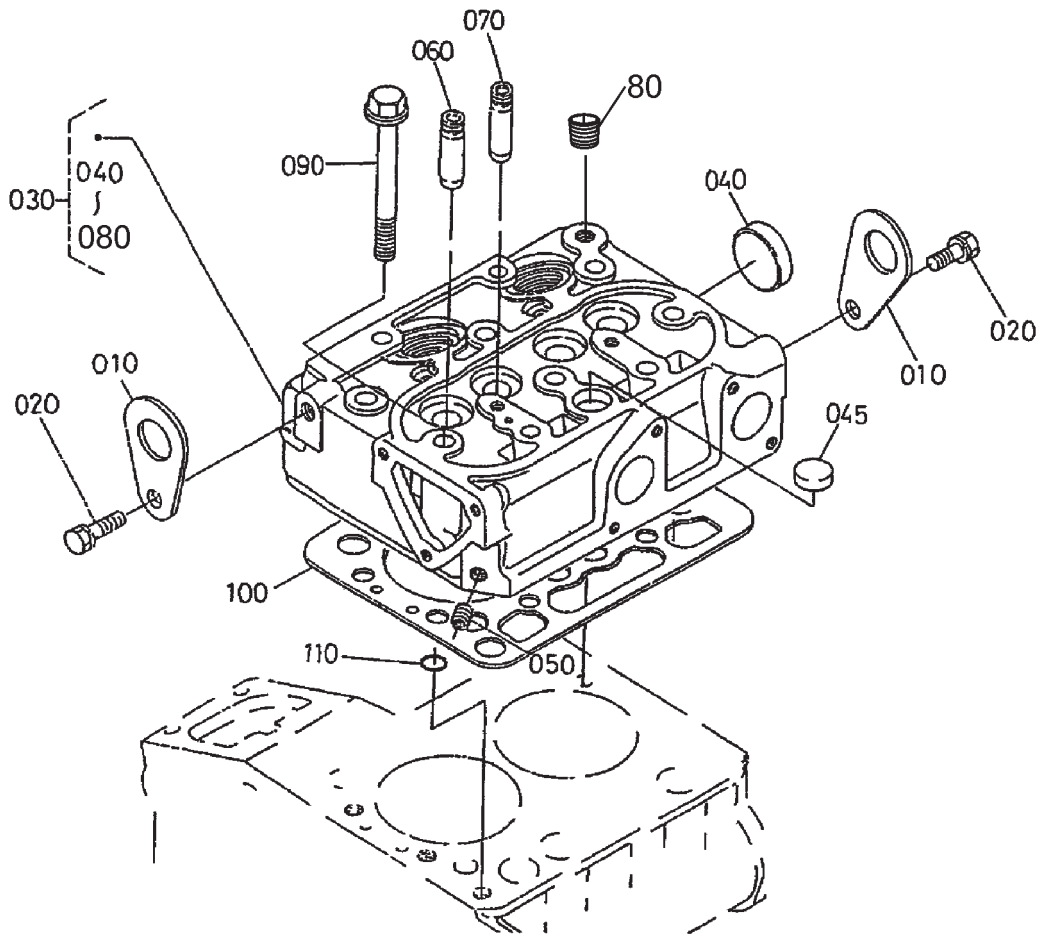

KUBOTA Z482-EB/E2B/E3B ENG. — CYLINDER HEAD ASSY.

CYLINDER HEAD ASSY.

<u>NO.</u>	<u>PART NO.</u>	<u>PART NAME</u>	<u>QTY.</u>	<u>REMARKS</u>
010	1522101750	HOOK, ENGINE	2	
020	0112360816	BOLT	2.....	Z482-EB
020	0112350816	BOLT	2.....	Z482-E2B AND Z482-E3B
030	1685503042	COMP. CYLINDER HEAD, Z482-EB	1.....	INCLUDES ITEMS W/#
030	1G95703023	COMP. CYLINDER HEAD, Z482-E2B	1.....	INCLUDES ITEMS W/%
030	1G68903040	COMP. CYLINDER HEAD, Z482-E3B	1.....	INCLUDES ITEMS W/\$
040#%\$	1532196260	CAP, SEALING.....	1.....	Z482-EB AND Z482-E3B
045%\$	1526103370	CAP, SEALING.....	1.....	Z482-E2B
050#%\$	1526196010	PLUG	1	
060#%\$	1584113540	GUIDE, INLET VALVE	2	
070#%\$	1584113560	GUIDE, EXHAUST VALVE	2	
080#	1584196020	PLUG	1.....	Z482-EB
090	1460103450	BOLT, CYLINDER HEAD	10	
100	1685103310	GASKET, CYLINDER HEAD	1	
100	1685103312	GASKET, CYLINDER HEAD.....	1.....	Z482-EB
110	1522133700	O-RING	1.....	Z482-E2B AND Z482-E3B

KUBOTA Z482-EB/E2B/E3B ENGINE — GEAR CASE ASSY.

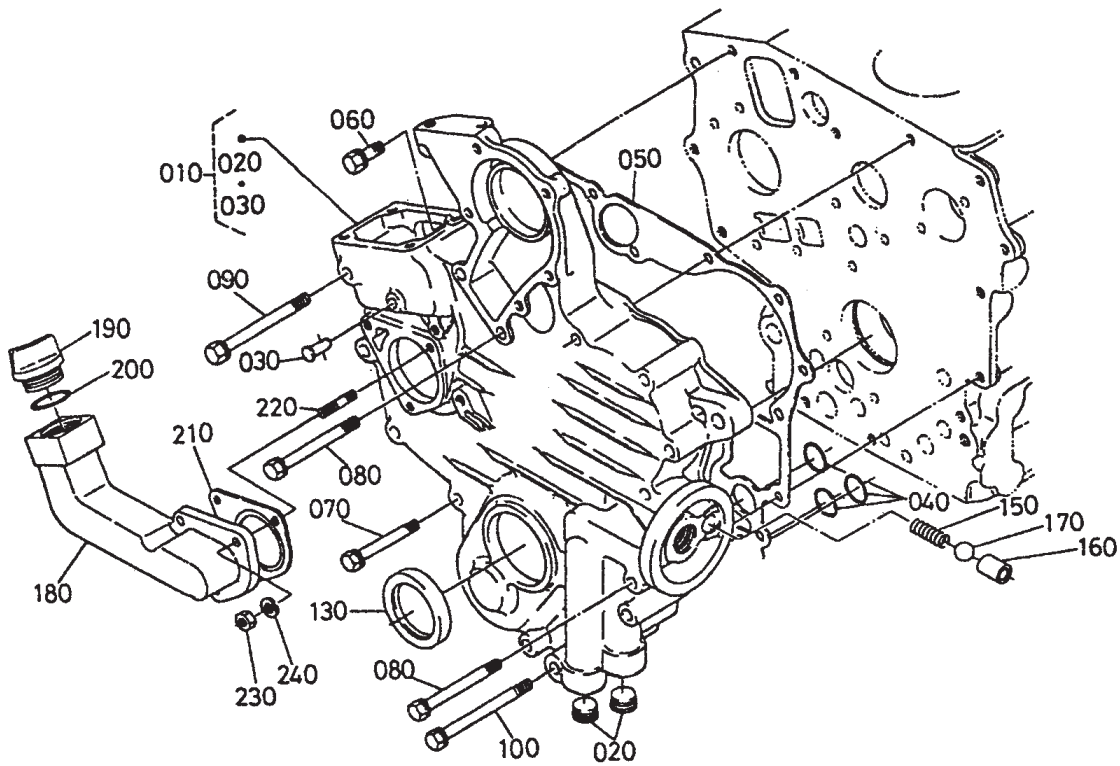

KUBOTA Z482-EB/E2B/E3B ENGINE — GEAR CASE ASSY.

GEAR CASE ASSY.

<u>NO.</u>	<u>PART NO.</u>	<u>PART NAME</u>	<u>QTY.</u>	<u>REMARKS</u>
010	1687504024	COMP. CASE, GEAR, Z482EB, Z482E2B	1.....	INCLUDES ITEMS W/#
010	1E05104024	COMP. CASE, GEAR, Z482E3B	1.....	INCLUDES ITEMS W/%
020#%	1685196010	PLUG	2.....	Z482EB
020#%	1552196030	PLUG	2.....	Z482-E2B AND Z482-E3B
030#%	1584156280	PIN, START SPRING	1	
040	0481406130	O-RING	3.....	Z482-EB AND Z482-E2B
050	1586204132	GASKET, GEAR CASE	1.....	Z482-EB AND Z482-E2B
050	1586204130	GASKET, GEAR CASE	1.....	Z482-E3B
060	0102350618	BOLT	1	
070	0102360650	BOLT	8	
080	1584191010	BOLT	5	
090	0102350670	BOLT	1.....	Z482EB
090	0102360670	BOLT	1.....	Z482E2B AND Z482-E3B
100	0102350675	BOLT	1	
130	1587704140	SEAL, OIL	1	
150	1685136950	SPRING	1	
160	1584136930	SEAT, VALVE	1	
170	0771503211	BALL	1	
180	1584633110	FLANGE, OIL FILLER	1	
190	1381133140	PLUG, OIL FILLER	1	
200	0481106230	O-RING	1	
210	1946188132	GASKET, H/M GEAR CASE	1	
220	1522188210	STUD	3	
230	0205650060	NUT	3	
240	0451260060	WASHER, LOCK	3	

KUBOTA Z482-EB/E2B/E3B ENGINE — HEAD COVER ASSY.

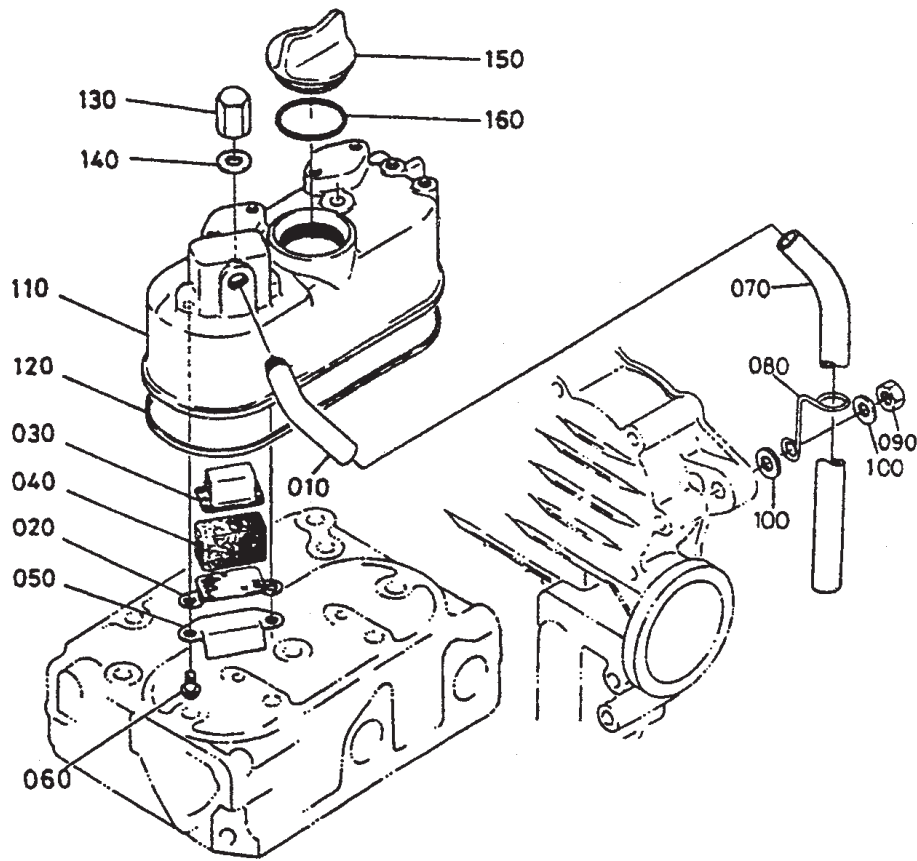

KUBOTA Z482-EB/E2B/E3B ENGINE — HEAD COVER ASSY.

HEAD COVER ASSY. (Z482-EB)

<u>NO.</u>	<u>PART NO.</u>	<u>PART NAME</u>	<u>QTY.</u>	<u>REMARKS</u>
010	1588105550	JOINT, BREATHER PIPE	1	
020	1584105140	PLATE, BREATHER ELEMENT	1	
030	1584105150	PLATE, BREATHER ELEMENT	1	
040	1584105670	ELEMENT, BREATHER	1	
050	1584105370	OIL SHIELD, BREATHER	1	
060	1686193310	SCREW	2	
070	1584705512	PIPE, BREATHER	1	
080	1584105590	CLAMP, PIPE	1	
090	0211450080	NUT	1	
100	0401360080	WASHER, FLATT	2	
110	1685114512	COVER, CYLINDER HEAD	1	Z482-EB
120	1685114522	GASKET, HEAD COVER	1	
130	1584114620	NUT, CAP	2	
140	1560196650	GASKET	2	
150	1585233140	PLUG, OIL FILLER	1	
160	0481150300	O-RING	1	

KUBOTA Z482-EB/E2B/E3B ENGINE — HEAD COVER ASSY.

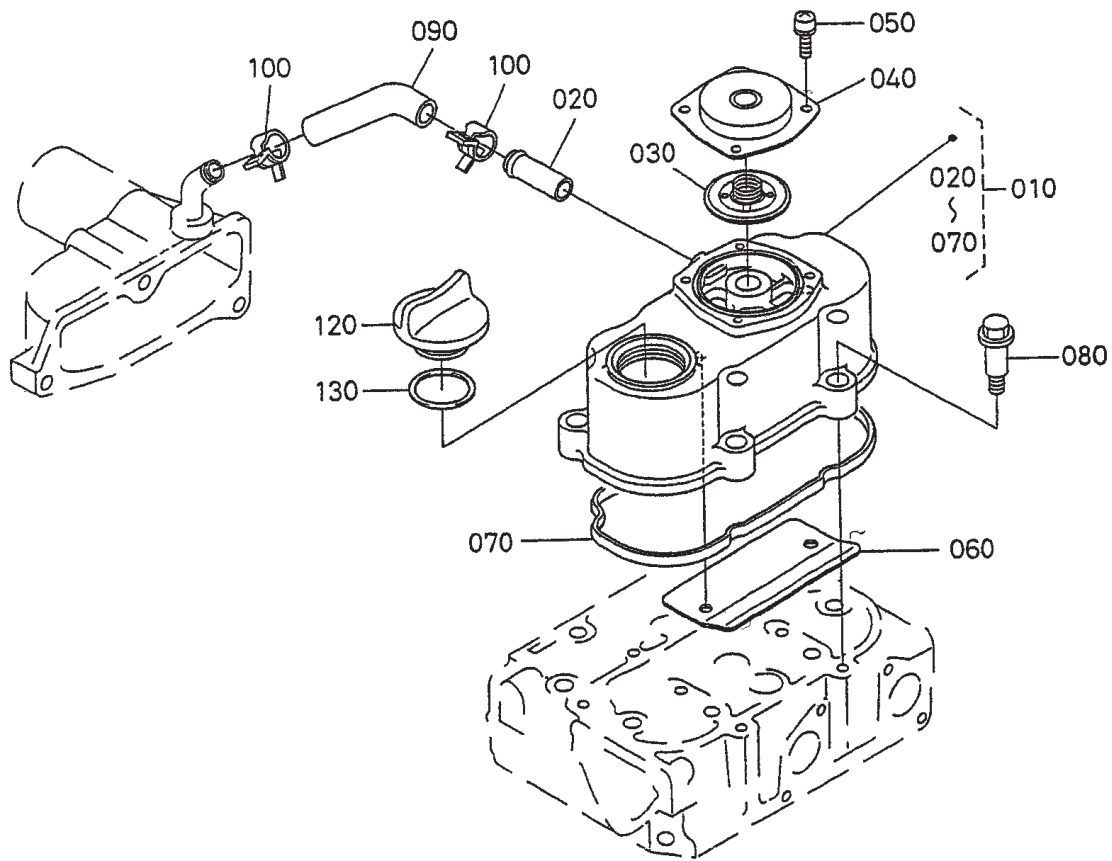

KUBOTA Z482-EB/E2B/E3B ENGINE — HEAD COVER ASSY.

HEAD COVER ASSY. (Z482-E2B/Z482-E3B)

<u>NO.</u>	<u>PART NO.</u>	<u>PART NAME</u>	<u>QTY.</u>	<u>REMARKS</u>
010	1G95714503	COVER CYLINDER HEAD, Z482-E2B	1.....	INCLUDES ITEMS W/#
010	1G95714504	COVER CYLINDER HEAD, Z482-E3B	1.....	INCLUDES ITEMS W/%
020#	1624173370	PIPE, WATER RETURN	1	
030#	1G91105203	COMP. VALVE BREATHER	1	
040#	1G80105120	COVER, BREATHER	1	
050#	0302450510	SCREW WITH WASHER	4	
060#	1G95805370	SHIELD, BREATHER	1.....	Z482-E2B
070#	1G95714520	GASKET, HEAD COVER	1	
080	1G91191022	BOLT	4	
090	1G96005512	TUBE, BREATHER	1	
100	0931888125	CLAMP, HOSE	2	
120	E915133140	PLUG, OIL FILTER	1	
130	0481450300	O-RING	1	

KUBOTA Z482-EB/E2B/E3B ENGINE — OIL FILTER ASSY.

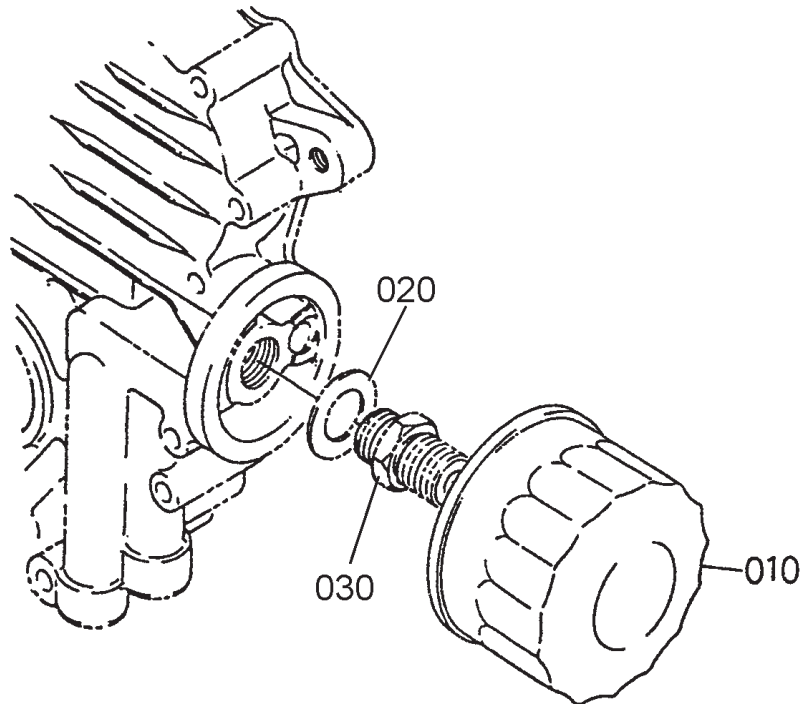

KUBOTA Z482-EB/E2B/E3B ENGINE — OIL FILTER ASSY.

OIL FILTER ASSY.

<u>NO.</u>	<u>PART NO.</u>	<u>PART NAME</u>	<u>QTY.</u>	<u>REMARKS</u>
010	7000015241	CARTRIDGE, OIL FILTER, Z482-EB.....	1.....	REPLACES P/N 1585399170
010	1585332430	CARTRIDGE, OIL FILTER.....	1.....	Z482-E2B AND Z482-E3B
020	1584194010	WASHER, FLAT	1	
030	1524132290	JOINT, PIPE	1	

KUBOTA Z482-EB/E2B/E3B ENG. — DIPSTICK AND GUIDE ASSY.

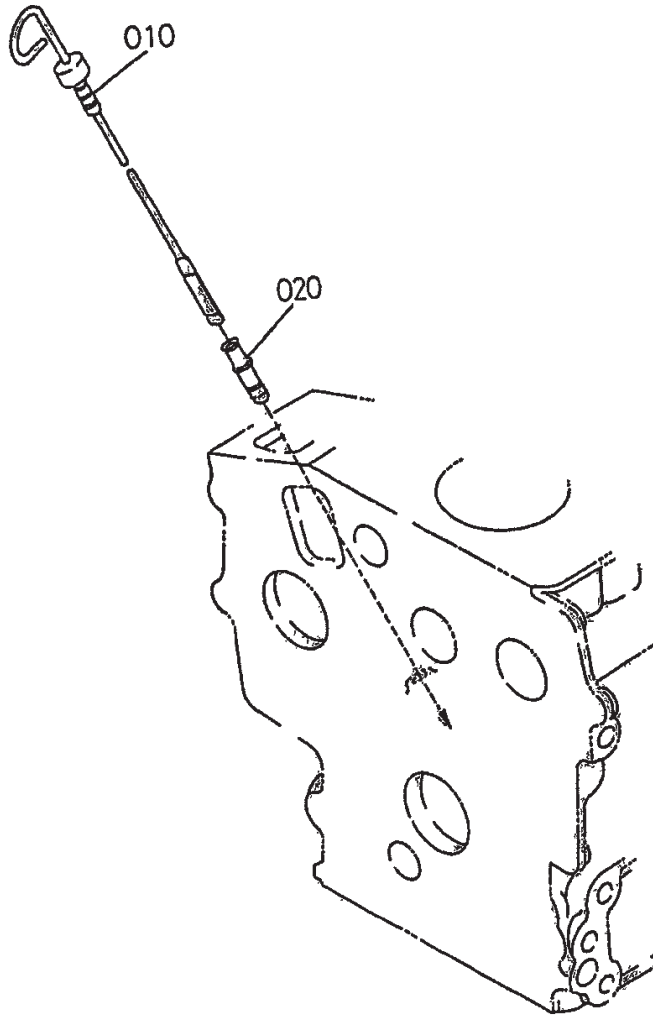

KUBOTA Z482-EB/E2B/E3B ENG. — DIPSTICK AND GUIDE ASSY.

DIPSTICK AND GUIDE ASSY.

<u>NO.</u>	<u>PART NO.</u>	<u>PART NAME</u>	<u>QTY.</u>	<u>REMARKS</u>
010	1685136410	GAUGE, OIL	1.....	Z482-EB
010	1G30436410	GAUGE, OIL	1.....	Z482-E2B AND Z482-E3B
020	1745636420	GUIDE, OIL GAUGE	1.....	Z482-E2B AND Z482-E3B

KUBOTA Z482-EB/E2B/E3B ENG. — MAIN BEARING CASE ASSY.

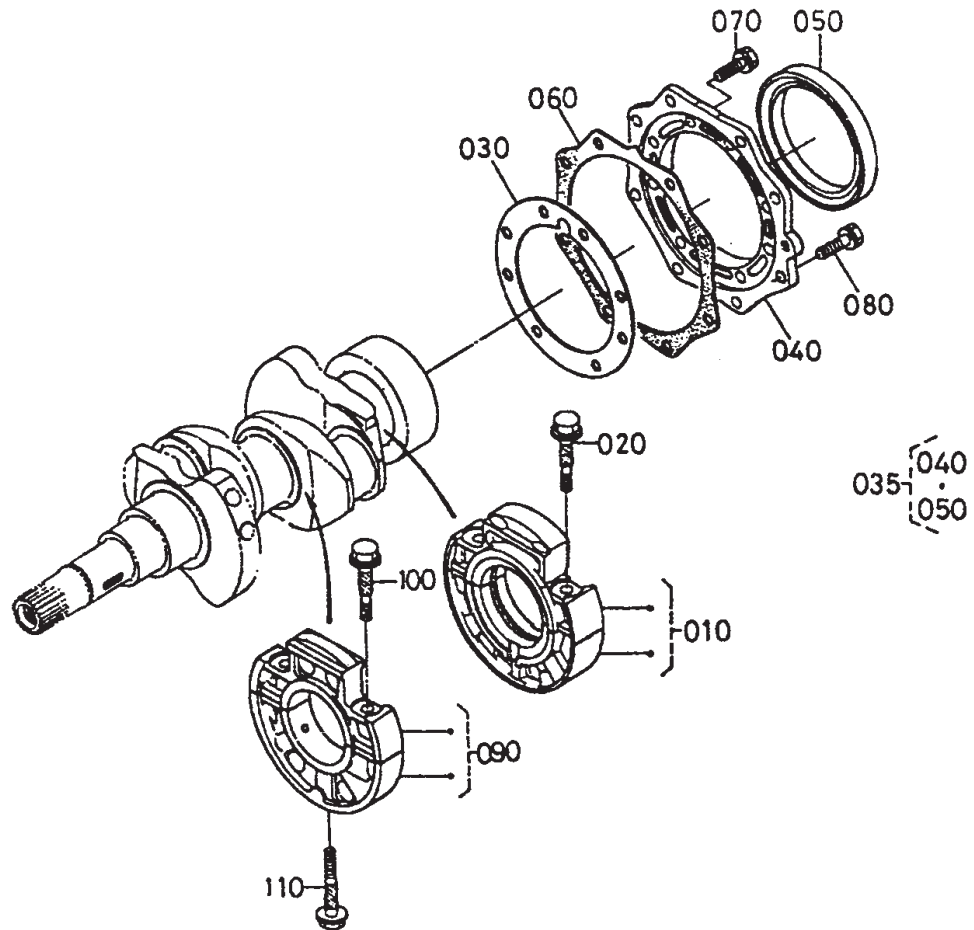

KUBOTA Z482-EB/E2B/E3B ENG. — MAIN BEARING CASE ASSY.

MAIN BEARING CASE ASSY.

<u>NO.</u>	<u>PART NO.</u>	<u>PART NAME</u>	<u>QTY.</u>	<u>REMARKS</u>
010	1685104092	ASSY. CASE, MAIN BEARING, Z482-EB/E2B ..1.....	1	INCLUDES ITEMS W/@
010	1685107090	ASSY. CASE, MAIN BEARING, Z482-E3B.....1.....	1	INCLUDES ITEMS W/\$
015@\$	1686123480	METAL, CRANKSHAFT M	1	
020@\$	1584104540	BOLT, BEARING CASE	2	
030	1585204360	GASKET, BEARING CASE	1	
035	1584104800	COVER ASSY., BRG CASE, Z482-EB ..1.....	1	INCLUDES ITEMS W/#
035	1584104803	COVER ASSY., BRG CASE, Z482-E2B/E3B.....1.....	1	INCLUDES ITEMS W/%
040#	1584104810	COVER, BEARING CASE ..1.....	1	Z482-EB
040%	1584104815	COVER, BEARING CASE ..1.....	1	Z482-E2B AND Z482-E3B
050#%	1921599160	SEAL, OIL	1	
060	1584104822	GASKET, CASE COVER ..1.....	1	Z482-EB AND Z482-E2B
060	1584104823	GASKET, CASE COVER ..1.....	1	Z482-E3B
070	0102350620	BOLT	8	
080	0102350622	BOLT	8	
090	1685104040	ASSY. CASE, MAIN BEARING ..1.....	1	Z482-EB AND Z482-E2B
090	1685107040	ASSY. CASE, MAIN BEARING ..1.....	1	Z482-E3B
100	1584104540	BOLT, BEARING CASE	2	
110	1584104562	BOLT, BEARING CASE	1	

KUBOTA Z482-EB/E2B/E3B ENGINE — CAMSHAFT AND IDLE GEAR ASSY.

CAMSHAFT AND IDLE GEAR SHAFT ASSY.

<u>NO.</u>	<u>PART NO.</u>	<u>PART NAME</u>	<u>QTY.</u>	<u>REMARKS</u>
010	1685115550	TAPPET	4.....	Z482-EB
010	1685115552	TAPPET	4.....	Z482-E2B AND Z482-E3B
020	1685115110	PUSH ROD	4	
030	1584116015	CAMSHAFT ASSY.....	1.....	INCLUDES ITEMS W/%
030	1584116019	CAMSHAFT ASSY.....	1.....	INCLUDES ITEMS W/\$
040\$	1552193610	SCREW, SET	1.....	Z482-EB
040A%	0771500401	BALL	1.....	Z482-E2B AND Z482-E3B
050%\$	1686416510	GEAR, CAM	1	
060%\$	0571200518	KEY, FEATHER	1	
070%\$	1584116270	STOPPER, CAMSHAFT	1	
080	0102350612	BOLT	2	
090	1587524013	COMP. GEAR, IDLE.....	1.....	INCLUDES ITEMS W/#
100#	1587524282	BUSH	1	
120	1587524370	COLLAR, IDLE GEAR	1	
130	1587524320	RING, SNAP	1	
140	1587524250	SHAFT, IDLE GEAR	1	
150	0102350614	BOLT	3	

KUBOTA Z482-EB/E2B/E3B ENG. — PISTON AND CRANKSHAFT ASSY.

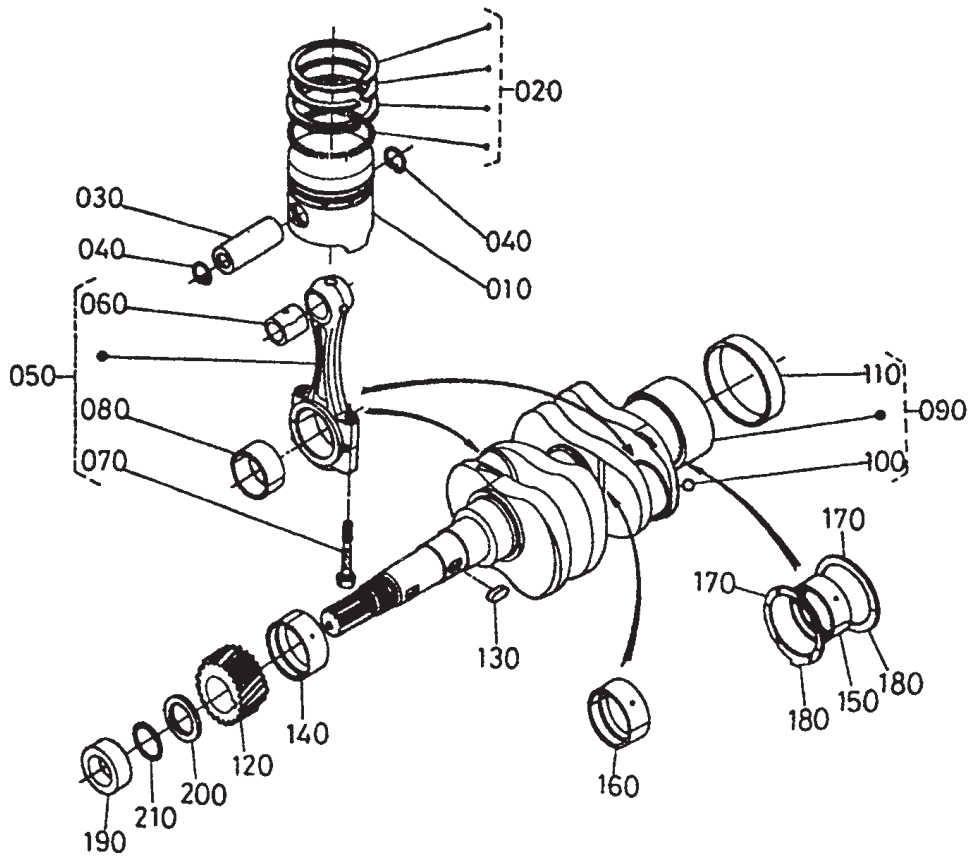

KUBOTA Z482-EB/E2B/E3B ENG. — PISTON AND CRANKSHAFT ASSY.

PISTON AND CRANKSHAFT ASSY.

<u>NO.</u>	<u>PART NO.</u>	<u>PART NAME</u>	<u>QTY.</u>	<u>REMARKS</u>
010	1685121112	PISTON STD	2.....	Z482-EB AND Z482-E2B
010	1685121114	PISTON STD	2.....	Z482-E3B
010	1685121900	PISTON +0.25MM.....	2.....	Z482-EB AND Z482-E2B
010	1685121903	PISTON +0.25MM.....	2.....	Z482-E3B
020	1685321050	ASSY. PISTON RING STD	2	
020	1685321090	ASSY. PISTON RING +0.25MM	2	
030	1685121310	PIN, PISTON	2	
040	1526121330	AIR CLIP, PISTON PIN	4	
050	1685122010	CONNECTING ROD ASSY., Z482-EB.....	2.....	INCLUDES ITEMS W/%
050	1685122015	CONN. ROD ASSY. Z482-E2B/E3B.....	2.....	INCLUDES ITEMS W/+
060%	1685121980	BUSH, PISTON PIN.....	2.....	Z482-EB
060+	1685121982	BUSH, PISTON PIN.....	2.....	Z482-E2B AND Z482-E3B
070%+	1685122140	BOLT, CONNECTING ROD	4	
080%+	1685122320	METAL, CRANKPIN M STD SET	2	
080	1586122970	METAL, CRANKPIN -0.20MM SET	2	
080	1586122980	METAL, CRANKPIN -0.40MM SET	2	
090	1685323030	CRANKSHAFT ASSY.....	1.....	INCLUDES ITEMS W/#
100#	0771503207	BALL	2	
110#	1921523280	SLEEVE, CRANKSHAFT	1	
120	1584124110	GEAR, CRANK	1	
130	0571200515	KEY, FEATHER	1	
140	1586123470	METAL, CRANKSHAFT STD	1	
140	1586123910	METAL, CRANKSHAFT -0.20MM	1	
140	1586123920	METAL, CRANKSHAFT -0.40MM	1	
150	1686123480	METAL, CRANKSHAFT M STD SET	1	
150	1569423930	METAL, CRANKSHAFT -0.20MMSET	1	
150	1569423940	METAL, CRANKSHAFT -0.40MMSET	1	
160	1686123490	METAL, CRANKSHAFT STD SET	1	
160	1586123860	METAL, CRANKSHAFT -0.20MM SET	1	
160	1586123870	METAL, CRANKSHAFT -0.40MM SET	1	
170	1526123530	METAL, SIDE STD	2	
170	1526123950	METAL, SIDE +0.20MM	2	
170	1526123960	METAL, SIDE +0.40MM	2	
180	1526123540	METAL, SIDE STD	2	
180	1526123970	METAL, SIDE +0.20MM	2	
180	1526123980	METAL, SIDE +0.40MM	2	
190	1584123250	COLLAR, CRANKSHAFT	1	
200	1588123310	SLINGER, OIL	1	
210	0481416220	O-RING	1	

KUBOTA Z482-EB/E2B/E3B ENGINE — FLYWHEEL ASSY.

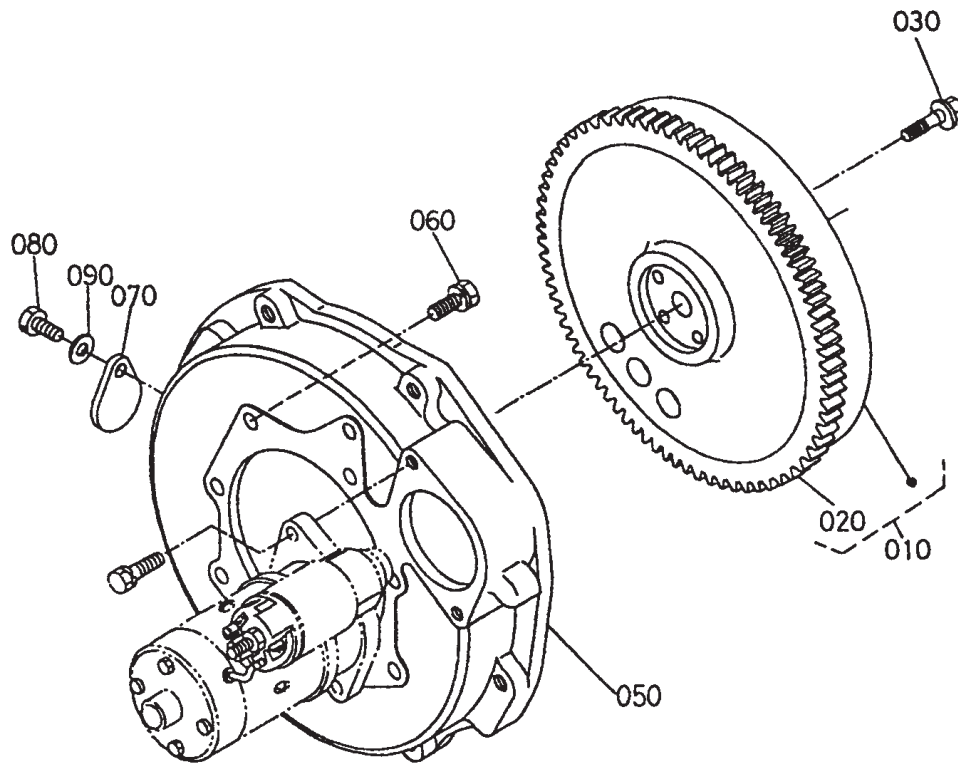

KUBOTA Z482-EB/E2B/E3B ENGINE — FLYWHEEL ASSY.

FLYWHEEL ASSY.

<u>NO.</u>	<u>PART NO.</u>	<u>PART NAME</u>	<u>QTY.</u>	<u>REMARKS</u>
010	1685125010	COMP. FLYWHEEL, Z482-EB.....	1.....	INCLUDES ITEMS W/#
010	1685125015	COMP. FLYWHEEL, Z482-E2B/E3B	1.....	INCLUDES ITEMS W/%
020#	1685163820	GEAR, RING, Z482-EB	1	
020%	1685163822	GEAR, RING, Z482-E2B AND Z482-E3B	1	
030	1585225160	BOLT, FLYWHEEL	5	
050	1584704612	HOUSING, FLYWHEEL	1	
060	0112350820	BOLT	10	
070	3122014170	COVER	1	
080	0112360814	BOLT	1	
090	0401360080	WASHER, FLAT	1	

KUBOTA Z482-EB/E2B/E3B ENG. — FUEL CAMSHAFT & GOV. SHAFT ASSY.

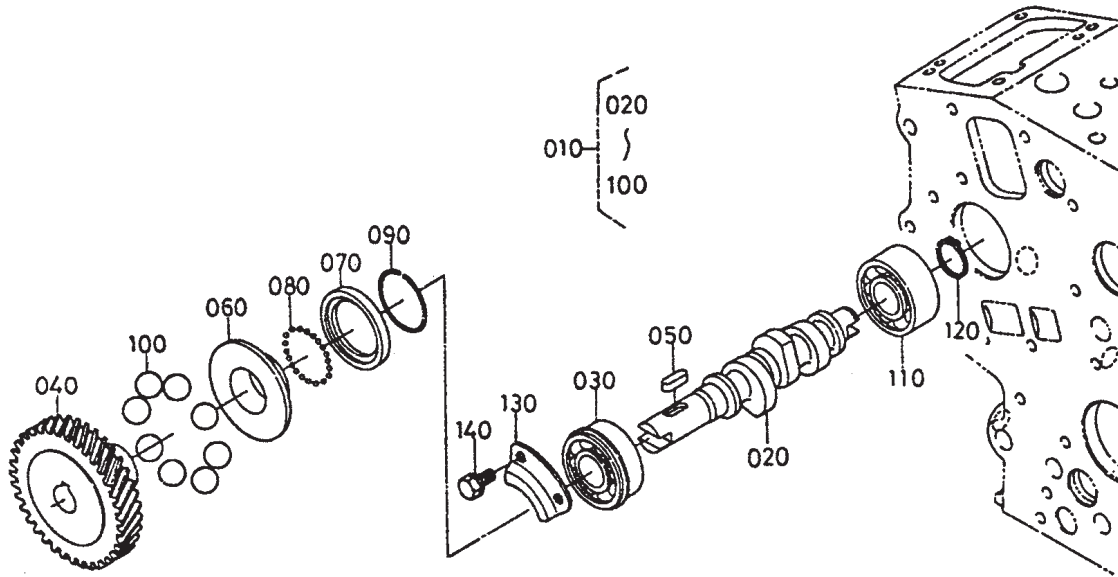

KUBOTA Z482-EB/E2B/E3B ENG. — FUEL CAMSHAFT & GOV. SHAFT ASSY.

FUEL CAMSHAFT AND GOVERNOR SHAFT ASSY.

NO.	PART NO.	PART NAME	QTY.	REMARKS
010	1685116020	CAMSHAFT ASSY., FUEL, Z482-EB/E2B.....	1.....	INCLUDES ITEMS W/#
010	1685116023	CAMSHAFT ASSY., FUEL, Z482-E3B.....	1.....	INCLUDES ITEMS W/\$
020#	1584116172	CAMSHAFT, FUEL	1	
030#	0815306203	BEARING, BALL	1	
040#	1685151150	GEAR, INJECTION PUMP	1	
050#	0571200515	KEY, FEATHER	1	
060#	1584155450	SLEEVE, GOVERNOR	1.....	Z482-EB AND Z482-E2B
060#	1584155452	SLEEVE, GOVERNOR	1.....	Z482-E3B
070#	1584155690	CASE, GOVERNOR BALL	1	
080#	0771500801	BALL	32	
090#	1526155470	CIR-CLIP, GOVERNOR SLEEVE	1	
100#	0771503217	BALL	8	
110	0810306203	BEARING, BALL	1.....	Z482-EB
110	1687197300	BEARING, BALL	1.....	Z482-E2B AND Z482-E3B
120	0461200170	CIR CLIP, EXTERNAL	1	
130	1584116320	STOPPER, FUEL. CAMSHAFT	1	
140	0102350612	BOLT	2	

KUBOTA Z482-EB/E2B/E3B ENG. — ENG. STOP LEVER ASSY.

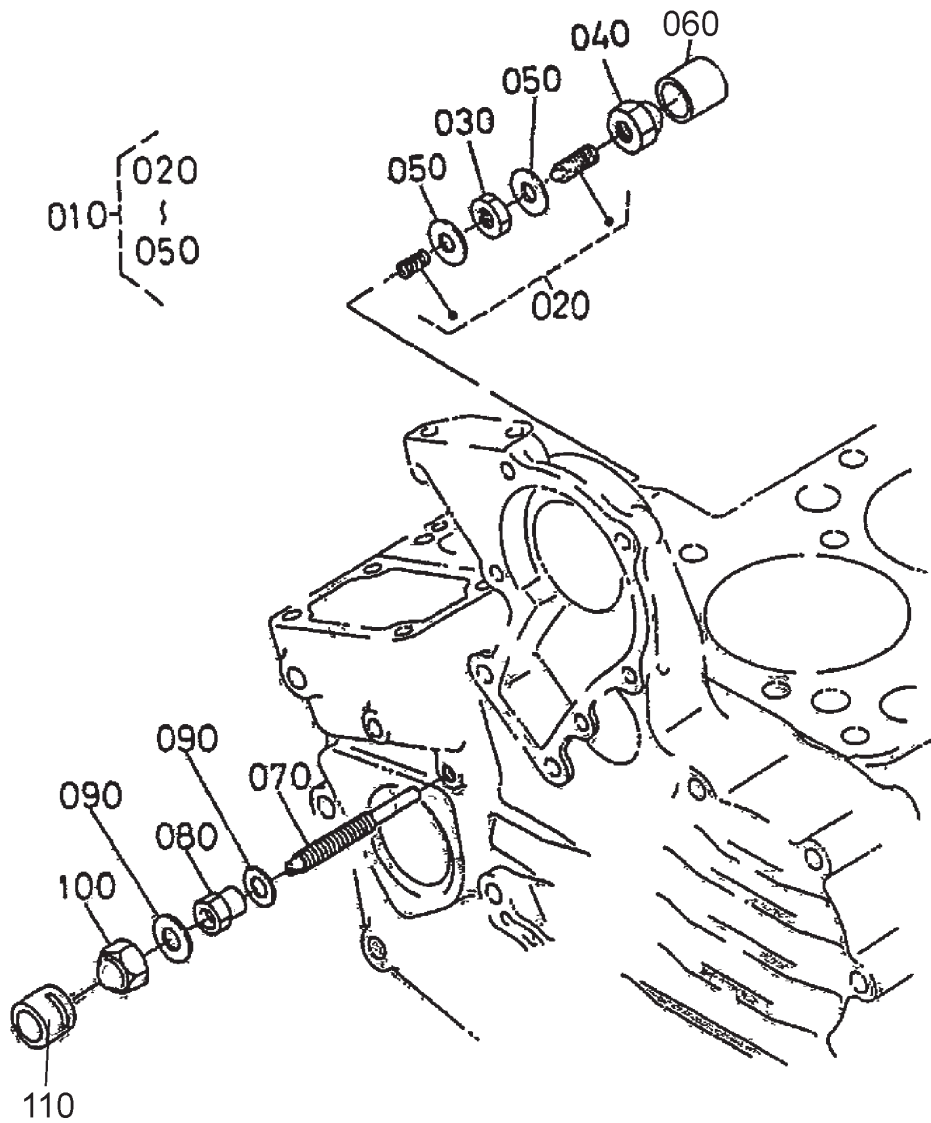

KUBOTA Z482-EB/E2B/E3B ENG. — ENG. STOP LEVER ASSY.

ENGINE STOP LEVER ASSY.

<u>NO.</u>	<u>PART NO.</u>	<u>PART NAME</u>	<u>QTY.</u>	<u>REMARKS</u>
010	1584154092	ASSY. APPARATUS, IDLE	1.....	INCLUDES ITEMS W/#
020#	1584154100	ASSY. BOLT, ADJUSTING	1	
030#	1526192020	NUT	1	
040#	1584154220	NUT, CAP	1	
050#	1502133660	GASKET	2	
060	1584154270	CAP	1	
070	1584154122	BOLT, ADJUSTING	1.....	Z482-EB
070	1584154123	BOLT, ADJUSTING	1.....	Z482-E2B AND Z482-E3B
080	1G03154210	NUT, LOCK	1	
090	1560196650	GASKET	2.....	Z482-EB
090	1560196650	GASKET	1.....	Z482-E2B AND Z482-E3B
095	1G02196650	GASKET	1.....	Z482-E2B/Z482-E3B ONLY
100	1584192330	NUT, CAP	1	
110	1G02154290	PIPE, LOCK.....	1.....	Z482-EB ONLY

KUBOTA Z482-EB/E2B/E3B ENG. — STOP SOLENOID ASSY.

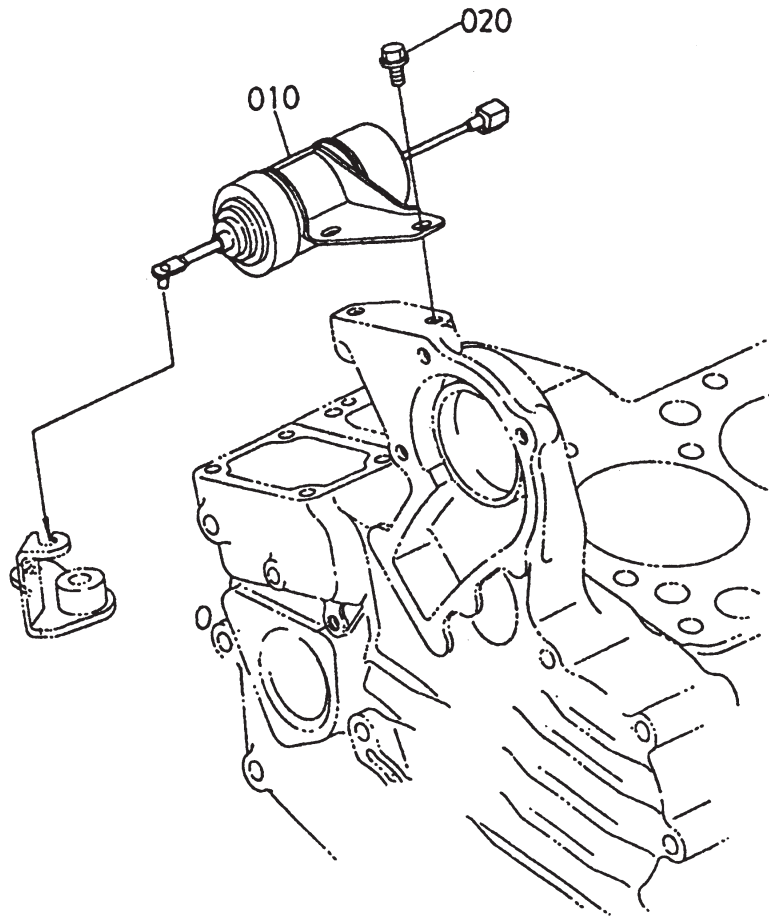

KUBOTA Z482-EB/E2B/E3B ENG. — STOP SOLENOID ASSY.

STOP SOLENOID ASSY.

<u>NO.</u>	<u>PART NO.</u>	<u>PART NAME</u>	<u>QTY.</u>	<u>REMARKS</u>
010	1685160010	SOLENOID, STOP	1.....	Z482-EB
010	1685160013	SOLENOID, STOP	1.....	Z482-E2B
010	1685160014	SOLENOID, STOP	1.....	Z482-E3B
020	0175450612	BOLT, FLANGE	2	

KUBOTA Z482-EB/E2B/E3B ENG. — INJECTION PUMP ASSY.

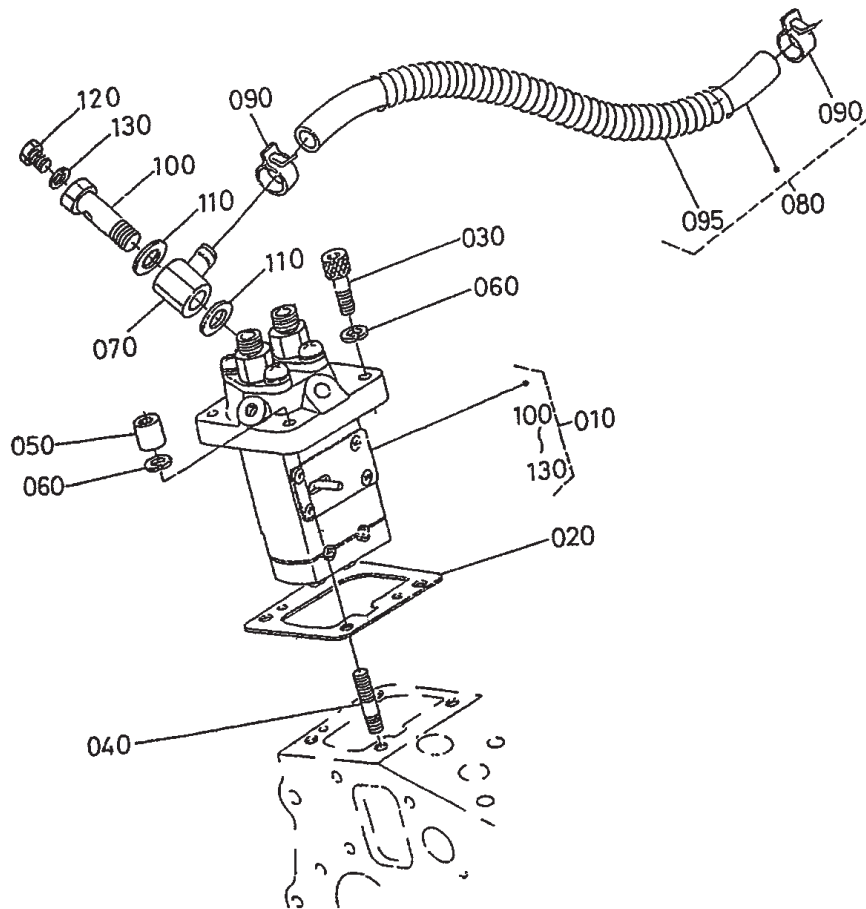

KUBOTA Z482-EB/E2B/E3B ENG. — INJECTION PUMP ASSY.

INJECTION PUMP ASSY.

<u>NO.</u>	<u>PART NO.</u>	<u>PART NAME</u>	<u>QTY.</u>	<u>REMARKS</u>
010	1600151010	PUMP ASSY., INJECTION	1.....	INCLUDES ITEMS W/%
020	1600152090	SHIM, INJECTION PUMP, 20 MM	1	
020	1600152110	SHIM, INJECTION PUMP, 25 MM	1	
020	1600152120	SHIM, INJECTION PUMP, 30 MM	1	
020	1G68952160	SHIM, INJECTION PUMP, 35 MM	1.....	Z482-E3B ONLY
020	1G68952200	SHIM, INJECTION PUMP, 175 MM	1.....	Z482-E3B ONLY
030	0131110620	BOLT, HEX-SOC-HD	3	
040	1584191500	STUD	1	
050	1584192320	NUT, CAP	1	
060	0451260060	WASHER, LOCK	4	
070	1584195680	JOINT, EYE	1	
080	1526342010	ASSY. PIPE, FUEL.....	1.....	INCLUDES ITEMS W/#
090#	1491142750	CLIP, PIPE	2	
095#	6659154250	SPRING, PIPE PROTECT	1	
100%	1584151320	SCREW HOLLOW	1.....	Z482-E2B /Z482-E3B ONLY
110%	1584196650	GASKET	2.....	Z482-E2B AND Z482-E3B ONLY
120%	1584151350	SCREW.....	1.....	Z482-E2B AND Z482-E3B ONLY
130%	1584196660	GASKET	1.....	Z482-E2B AND Z482-E3B ONLY

KUBOTA Z 482-EB ENGINE—INJECTION PUMP COMPONENTS ASSY.

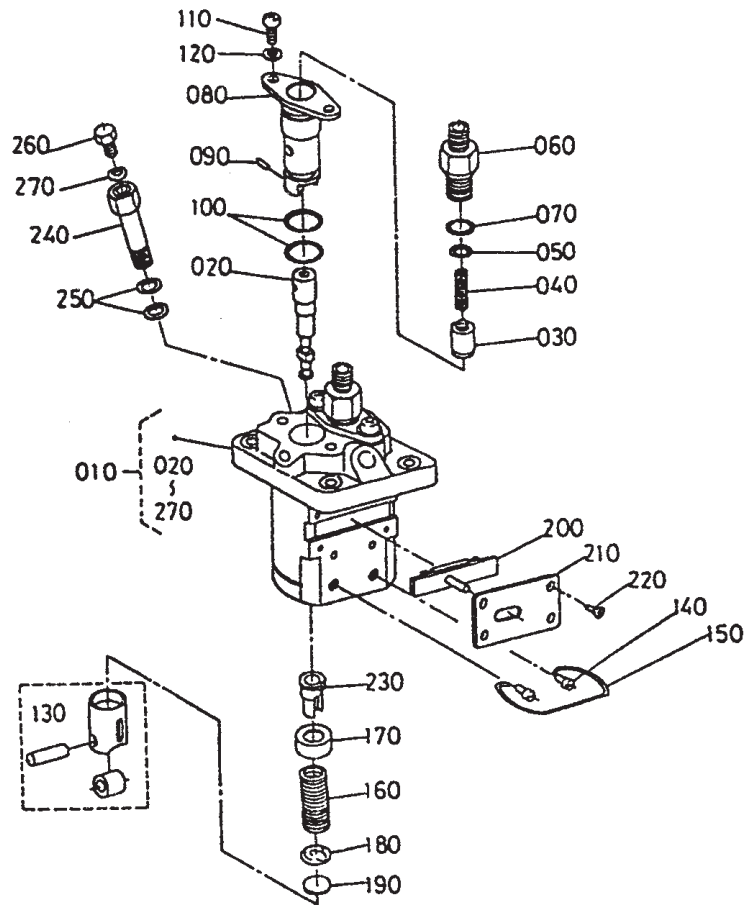

KUBOTA Z 482-EB ENGINE—INJECTION PUMP COMPONENTS ASSY.

INJECTION PUMP COMPONENTS ASSY.

<u>NO.</u>	<u>PART NO.</u>	<u>PART NAME</u>	<u>QTY.</u>	<u>REMARKS</u>
010	1600151010	INJECTION PUMP ASSY., Z482-EB	1.....	INCLUDES ITEMS W/#
010	1754851010	INJECTION PUMP ASSY., Z482-E2B/E3B	1.....	INCLUDES ITEMS W/%
020#	1685151050	PLUNGER, PUMP, Z482-EB	2	
020%	1754851050	PLUNGER, PUMP, Z482-E2B/E3B	2	
030#	1584151030	VALVE, DELIVERY	2	
040#	1584151230	SPRING, DELIV. VALVE	2	
050#	1584151240	GASKET, DELIV. VALVE	2	
060#	1685151220	HOLDER, DELIV. VALVE	2	
070#	1584196760	O-RING	2	
080#	1584151560	FLANGE, SLEEVE	2	
090#	1584194570	PIN, JOINT	2	
100#	1584151200	O-RING	4	
110#	1586291430	SCREW	4	
120#	1585251470	WASHER	4	
130#	1584151070	ASSY. TAPPET	2	
140#	1584151250	PIN, TAPPET GUIDE	2	
150#	1584151430	PIN, CLAMP	1	
160#	1584151280	SPRING, PLUNGER	2	
170#	1584151270	SEAT, SPRING UPPER	2	
180#	1584151290	SEAT, SPRING LOWER	2	
190#	1584151490	SHIM	1	
200#	1584151060	SHIM	1	
210#	1584151540	PLATE	1	
220#	1584193110	SCREW, CSK-HD	4	
230#	1584151380	SLEEVE, CONTROL	2	
240#	1584151320	SCREW, FOLLOW	1	
250#	1584196650	GASKET	2	
260#	1584151350	SCREW	1	
270#	1584196660	GASKET	1	

KUBOTA Z482-EB/E2B/E3B ENG. — SPEED CONTROL PLATE ASSY.

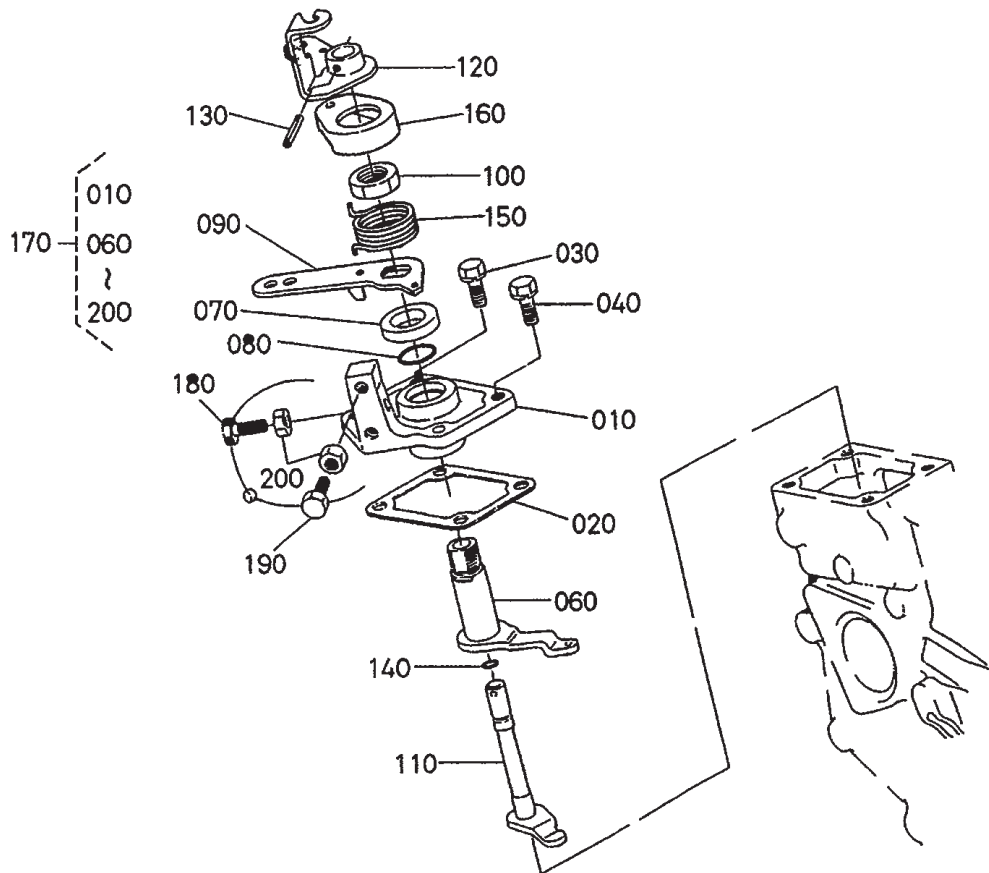

KUBOTA Z482-EB/E2B/E3B ENG. — SPEED CONTROL PLATE ASSY.

SPEED CONTROL PLATE ASSY.

<u>NO.</u>	<u>PART NO.</u>	<u>PART NAME</u>	<u>QTY.</u>	<u>REMARKS</u>
010	1584157110	PLATE, SPEED CONTROL	1.....	Z482-EB
010%	1584157112	PLATE, SPEED CONTROL	1.....	Z482-E2B AND Z482-E3B
020	1584157212	GASKET, CONTROL PLATE	1	
030	0102350618	BOLT	2	
040	0105350618	BOLT	2.....	Z482-EB AND Z482-E2B
040	1687191050	BOLT	2.....	Z482-E3B
050	1560196650	GASKET	2.....	Z482-EB AND Z482-E2B
060	1584156110	LEVER, GOVERNOR	1.....	Z482-EB
060%	1584156112	LEVER, GOVERNOR	1.....	Z482-E2B AND Z482-E3B
070	1584157240	COLLAR.....	1.....	Z482-EB
070	1928057240	COLLAR.....	1.....	Z482-E2B AND Z482-E3B
080%	0481410160	O-RING	1	
090%	1666757150	LEVER, SPEED CONTROL	1	
100	1584192010	NUT, SPEED CONTROL	2.....	Z482-EB
100%	1686692010	NUT, SPEED CONTROL	2.....	Z482-E2B AND Z482-E3B
110	1687857740	SHAFT, LEVER.....	1.....	Z482-EB
110%	1687857742	SHAFT, LEVER.....	1.....	Z482-E2B AND Z482-E3B
120	1685157720	LEVER, ENGINE STOP.....	1.....	Z482-EB
120%	1685157724	LEVER, ENGINE STOP.....	1.....	Z482-E2B AND Z482-E3B
130	0541100318	PIN, SPRING	1.....	Z482-EB
130%	0541100314	PIN, SPRING	1.....	Z482-E2B AND Z482-E3B
140%	0481410070	O-RING	1	
150%	1687857920	SPRING, RETURN	1	
160	1686657300	CAP.....	1.....	Z482-EB
160%	1686657302	CAP.....	1.....	Z482-E2B AND Z482-E3B
170%	1756157013	COMP. PLATE, SPEED CO.....	1.....	INCLUDES ITEMS W%
180%	1920291010	BOLT	2.....	Z482-E3B ONLY
190%	1920291010	BOLT	3.....	Z482-E3B ONLY
200%	0205650060	NUT.....	3.....	Z482-E3B ONLY

KUBOTA Z482-EB/E2B/E3B ENG. — NOZZLE HOLDER AND GLOW ASSY.

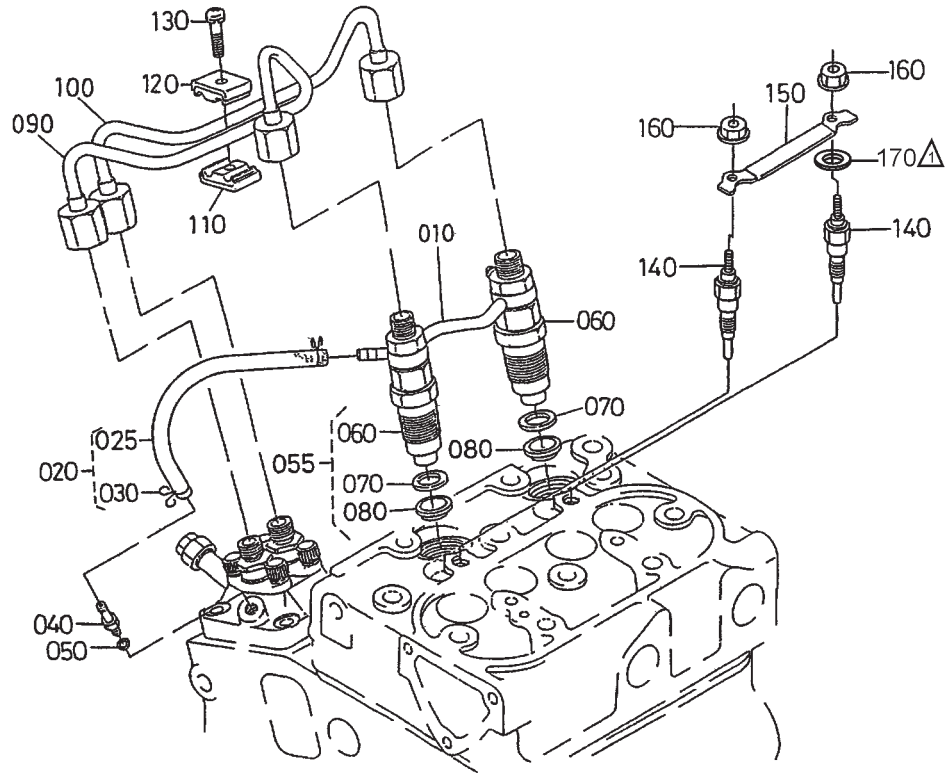

NOTES

- 1 ITEM 170, FLAT WASHER IS USED ON KUBOTA Z482EB ENGINE ONLY.

KUBOTA Z482-EB/E2B/E3B ENG. — NOZZLE HOLDER AND GLOW ASSY.

NOZZLE HOLDER AND GLOW PLUG ASSY.

<u>NO.</u>	<u>PART NO.</u>	<u>PART NAME</u>	<u>QTY.</u>	<u>REMARKS</u>
010	1585242502	PIPE ASSY., OVER FLOW	1	
020	1584142500	PIPE ASSY., OVER FLOW	1	INCLUDES ITEMS W/#
025#	1584142520	PIPE, FUEL OVER FLOW	1	
030#	1497142750	CLIP, PIPE	2	
040	1584151360	SCREW, AIR BREATHER	1	
050	1560196650	GASKET	1	
055	1600153900	KIT, HOLDER NOZZLE	2	
060	1600153000	HOLDER ASSY., NOZZLE	2	
070	1584153622	GASKET	2	
075	1907753650	SEAL, HEAT	2	
090	1685153712	PIPE, INJECTION.....	1	Z482-EB
090	1685153713	PIPE, INJECTION.....	1	Z482-E2B
090	1G68653710	PIPE, INJECTION.....	1	Z482-E3B
100	1685153722	PIPE, INJECTION.....	1	Z482-EB
100	1685153723	PIPE, INJECTION.....	1	Z482-E2B
100	1G68653720	PIPE, INJECTION.....	1	Z482-E3B
110	1584153850	CLAMP, PIPE	1	
120	1584153860	CLAMP, PIPE	1	
130	0302450520	SCREW, WITH WASHER	1	
140	1685165510	GLOW PLUG	2	Z482-EB
140	1685165512	GLOW PLUG	2	Z482-E2B AND Z482-E3B
150	1685165560	CORD, GLOW PLUG	1	
160	0276150040	NUT, FLANGE	2	
170	0401360040	WASHER, FLAT	2	Z482-EB ONLY

KUBOTA Z482-EB/E2B/E3B ENGINE — NOZZLE HOLDER ASSY.

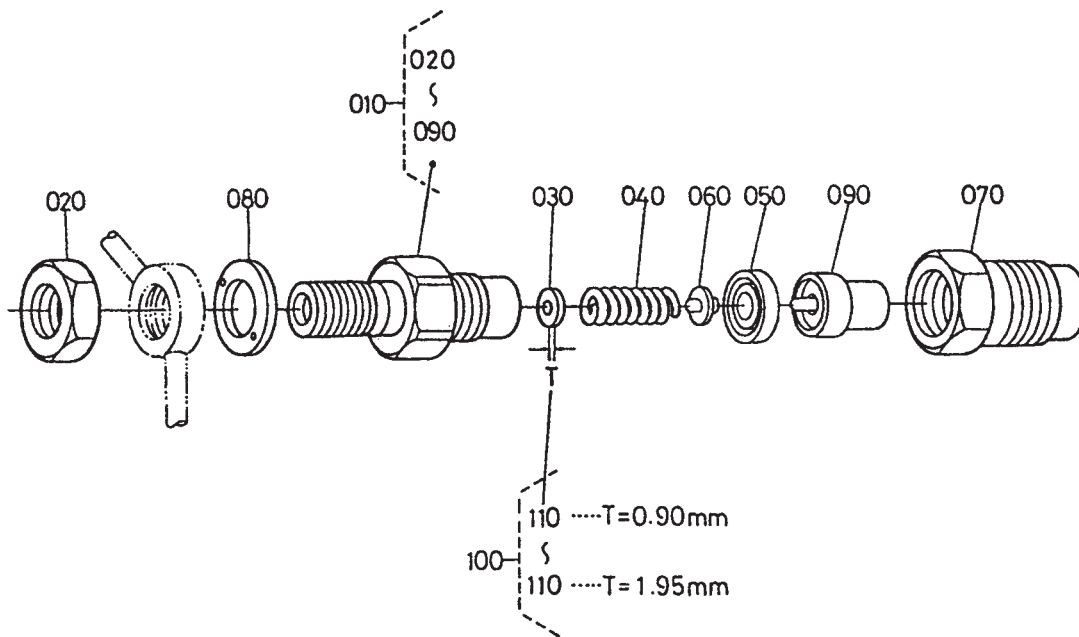

KUBOTA Z482-EB/E2B/E3B ENGINE — NOZZLE HOLDER ASSY.



NOZZLE HOLDER ASSY.

<u>NO.</u>	<u>PART NO.</u>	<u>PART NAME</u>	<u>QTY.</u>	<u>REMARKS</u>
10	1600153000	ASSY. HOLDER, NOZZLE	2	INCLUDES ITEMS W/ %
20%	1584192030	NUT	2	
30%	1584153230	WASHER, ADJUSTING	2	
40%	1584153170	SPRING, NOZZLE	2	
50%	1584153350	PIECE, DISTANCE	2	
60%	1584153160	PUSH ROD	2	
70%	1647553280	NUT, NOZZLE	2	
80%	1584194040	WASHER	2	
90%	1685153610	PIECE NOZZLE	2	
100	1584198100	ASSY. WASHER, ADJUST	2	INCLUDES ITEMS W/#OPTION
110#	1584153230	WASHER, ADJUSTING	2	0.900MM
110#	1584198510	WASHER, ADJUSTING	2	0.925MM
110#	1584198520	WASHER, ADJUSTING	2	0.950MM
110#	1584198530	WASHER, ADJUSTING	2	0.975MM
110#	1584198540	WASHER, ADJUSTING	2	1.000MM
110#	1584198550	WASHER, ADJUSTING	2	1.025MM
110#	1584198560	WASHER, ADJUSTING	2	1.050MM
110#	1584198570	WASHER, ADJUSTING	2	1.075MM
110#	1584198580	WASHER, ADJUSTING	2	1.100MM
110#	1584198590	WASHER, ADJUSTING	2	1.125MM
110#	1584198600	WASHER, ADJUSTING	2	1.150MM
110#	1584198610	WASHER, ADJUSTING	2	1.175MM
110#	1584198620	WASHER, ADJUSTING	2	1.200MM
110#	1584198630	WASHER, ADJUSTING	2	1.225MM
110#	1584198640	WASHER, ADJUSTING	2	1.250MM
110#	1584198650	WASHER, ADJUSTING	2	1.275MM
110#	1584198660	WASHER, ADJUSTING	2	1.300MM
110#	1584198670	WASHER, ADJUSTING	2	1.325MM
110#	1584198680	WASHER, ADJUSTING	2	1.350MM
110#	1584198690	WASHER, ADJUSTING	2	1.375MM
110#	1584198700	WASHER, ADJUSTING	2	1.400MM
110#	1584198710	WASHER, ADJUSTING	2	1.425MM
110#	1584198720	WASHER, ADJUSTING	2	1.450MM
110#	1584198730	WASHER, ADJUSTING	2	1.475MM
110#	1584198740	WASHER, ADJUSTING	2	1.500MM
110#	1584198750	WASHER, ADJUSTING	2	1.525MM
110#	1584198760	WASHER, ADJUSTING	2	1.550MM
110#	1584198770	WASHER, ADJUSTING	2	1.575MM
110#	1584198780	WASHER, ADJUSTING	2	1.600MM
110#	1584198790	WASHER, ADJUSTING	2	1.625MM
110#	1584198800	WASHER, ADJUSTING	2	1.650MM
110#	1584198810	WASHER, ADJUSTING	2	1.675MM
110#	1584198820	WASHER, ADJUSTING	2	1.700MM
110#	1584198830	WASHER, ADJUSTING	2	1.725MM
110#	1584198840	WASHER, ADJUSTING	2	1.750MM
110#	1584198850	WASHER, ADJUSTING	2	1.775MM
110#	1584198860	WASHER, ADJUSTING	2	1.800MM
110#	1584198870	WASHER, ADJUSTING	2	1.825MM
110#	1584198880	WASHER, ADJUSTING	2	1.850MM
110#	1584198890	WASHER, ADJUSTING	2	1.875MM
110#	1584198900	WASHER, ADJUSTING	2	1.900MM
110#	1584198910	WASHER, ADJUSTING	2	1.925MM
110#	1584198920	WASHER, ADJUSTING	2	1.950MM

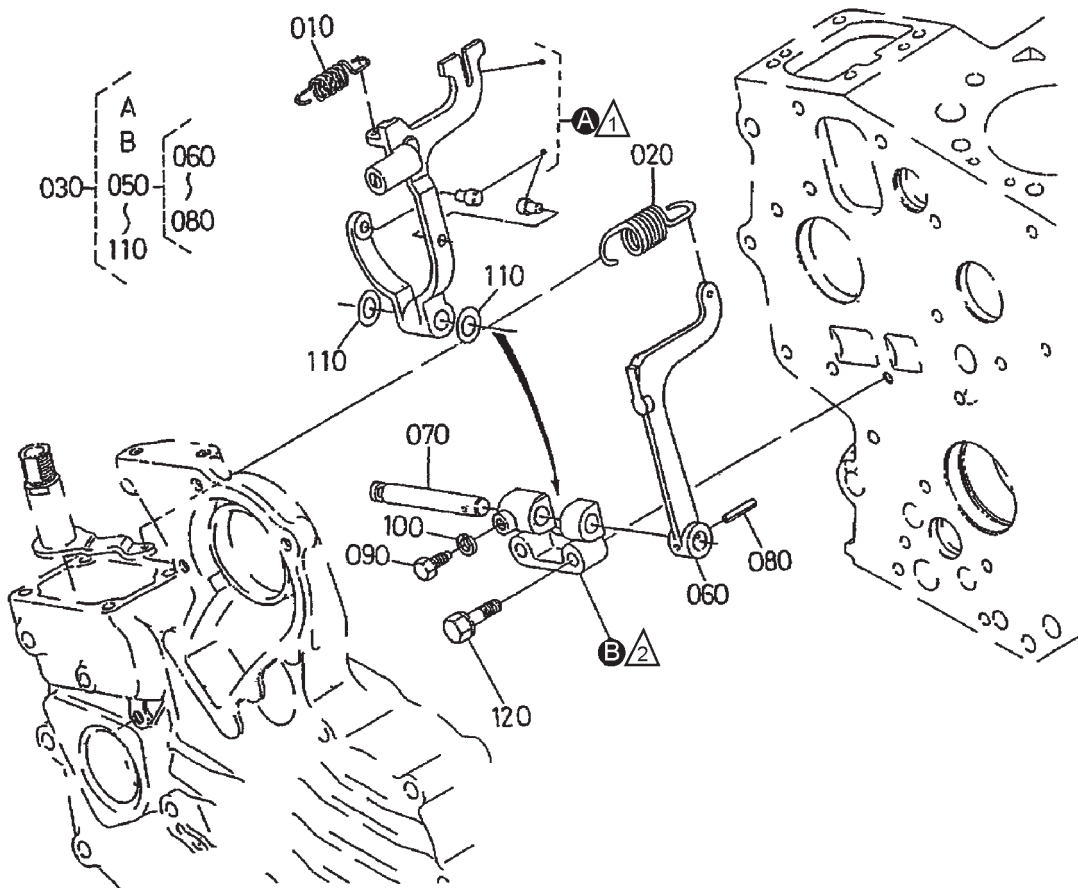
KUBOTA Z482-EB/E2B/E3B ENGINE — FORK LEVER ASSY.



NOTES

-  FORK LEVER ITEM **A** NOT SOLD SEPARATELY.
-  HOLDER, FORK LEVER ITEM **B** NOT SOLD SEPARATELY.

KUBOTA Z482-EB/E2B/E3B ENGINE — FORK LEVER ASSY.

FORK LEVER ASSY.

<u>NO.</u>	<u>PART NO.</u>	<u>PART NAME</u>	<u>QTY.</u>	<u>REMARKS</u>
010	1685156480	SPRING, START	1	
020	1946156410	SPRING, GOVERNOR	1	
030	1754856054	LEVER, FORK ASSY.....	1	INCLUDES ITEMS/#
A#		LEVER, FORK COMP	1	NOT SOLD SEPARATELY
B#		HOLDER, FORK LEVER	1	NOT SOLD SEPARATELY
050#	1584156060	LEVER, FORK ASSY.....	1	INCLUDES ITEMS W/%
060#	1584156130	LEVER, FORK	1	
070#	1584156150	SHAFT, FORK LEVER	1	
080#	0541100318	PIN, SPRING	1	
090#	1526166410	BOLT	1	
100#	0451260050	WASHER, LOCK	1	
110#	1666255620	WASHER, FLAT	2	Z482-E2B AND Z482-E3B ONLY
120	0102350635	BOLT	2	

KUBOTA Z482-EB/E2B/E3B ENGINE — FUEL FILTER ASSY.

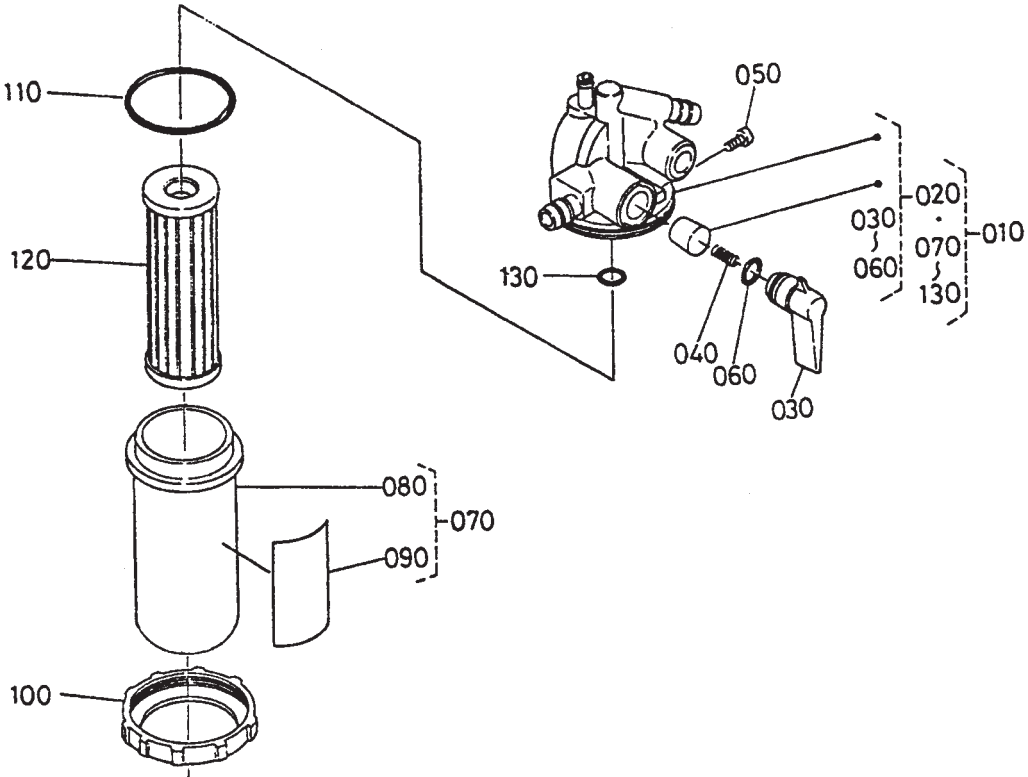

KUBOTA Z482-EB/E2B/E3B ENGINE — FUEL FILTER ASSY.

FUEL FILTER ASSY.

<u>NO.</u>	<u>PART NO.</u>	<u>PART NAME</u>	<u>QTY.</u>	<u>REMARKS</u>
010	1553143010	FILTER, FUEL ASSY.....	1.....	INCLUDES ITEMS W/\$ REPLACES P/N 1553143012
020\$	1553143110	COMP. BODY, COCK	1.....	INCLUDES ITEMS W/#
030\$#	1430143522	LEVER, COCK	1	
040 \$#	1430143820	SPRING, VALVE	1	
050\$#	1430143830	SCREW, SET	1	
060\$#	1430143840	O-RING, LEVER	1	
070\$	1539343100	CUP ASSY., FILTER	1.....	INCLUDES ITEMS W/%
080\$%	1539343580	CUP, FILTER	1	
090*%	1687388430	LABEL, FUEL	1	
100\$	1430143590	RING, RETAINING	1	
110\$	1430143650	O-RING, FILTER CUP	1.....	Z482-EB AND Z482-E2B
110\$	0481600390	O-RING, FILTER CUP	1.....	Z482-E3B ONLY
120\$	1523143560	ELEMENT, FUEL FILTER	1.....	Z482-EB AND Z482-E2B
120\$	1T02143560	ELEMENT, FUEL FILTER	1.....	Z482-E3B
130\$	1430143570	O-RING, FILTER		

KUBOTA Z482-EB/E2B/E3B ENGINE—FUEL PUMP ASSY.

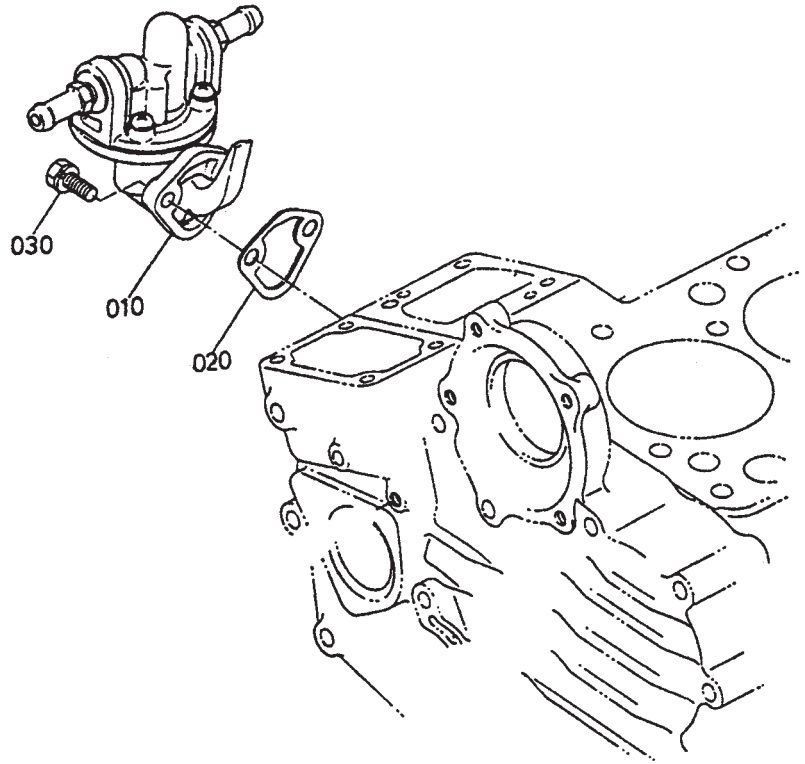

KUBOTA Z482-EB/E2B/E3B ENGINE—FUEL PUMP ASSY.

FUEL PUMP ASSY.

<u>NO.</u>	<u>PART NO.</u>	<u>PART NAME</u>	<u>QTY.</u>	<u>REMARKS</u>
010	1582152030	FUEL PUMP ASSY.	1	
020	1626452140	GASKET, FUEL PUMP	1	
030	0102350616	BOLT	2	

KUBOTA Z482-EB/E2B/E3B ENGINE — DYNAMO & PULLEY ASSY.

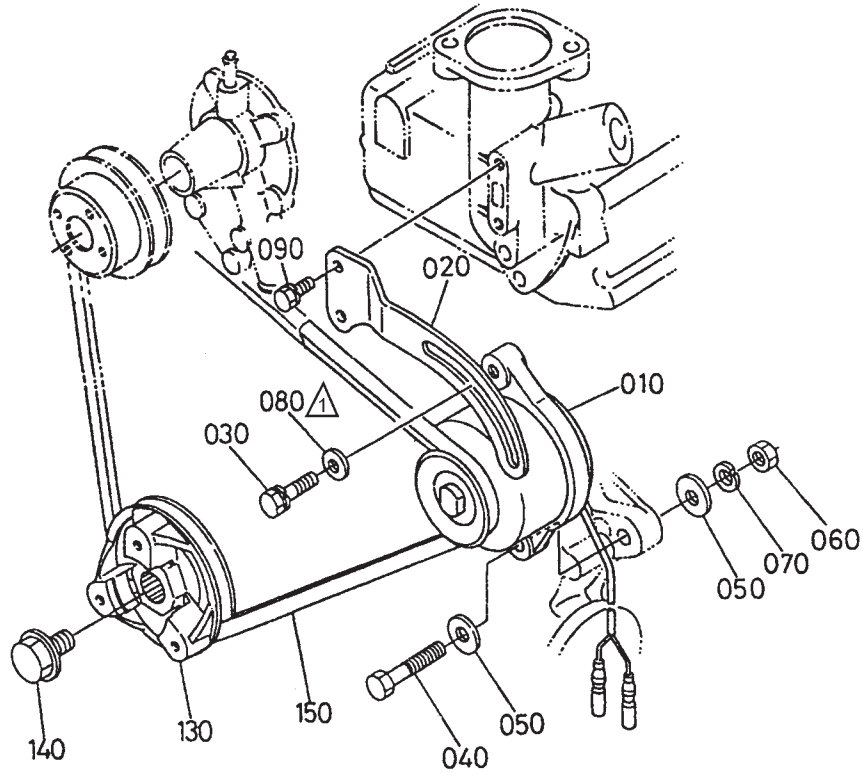

NOTES

- ① ITEM 080, FLAT WASHER IS USED ON KUBOTA Z482-EB ENGINE ONLY.

KUBOTA Z482-EB/E2B/E3B ENGINE — DYNAMO & PULLEY ASSY.

DYNAMO AND PULLEY ASSY.

<u>NO.</u>	<u>PART NO.</u>	<u>PART NAME</u>	<u>QTY.</u>	<u>REMARKS</u>
010	1753164010	DYNAMO ASSY.	1.....	Z482-EB
010	1753164012	DYNAMO ASSY.	1.....	Z482-E2B AND Z482-E3B
020	1259964420	STAY, DYNAMO	1	
030	0112350830	BOLT	1.....	Z482-EB
030	1687191030	BOLT	1.....	Z482-E2B AND Z482-E3B
040	0115350855	BOLT	1	
050	0401360080	WASHER, FLAT	2	
060	0211450080	NUT	1	
070	0451260080	WASHER, LOCK	1	
080	0401560080	WASHER, FLAT	1.....	Z482-EB ONLY
090	0102350616	BOLT	2	
130	1685174280	PULLEY, FAN DRIVE	1	
140	1588191030	BOLT	1	
150	1980572530	BELT, FAN (34.5 IN)	1	

KUBOTA Z482-EB/E2B/E3B ENGINE — DYNAMO ASSY.

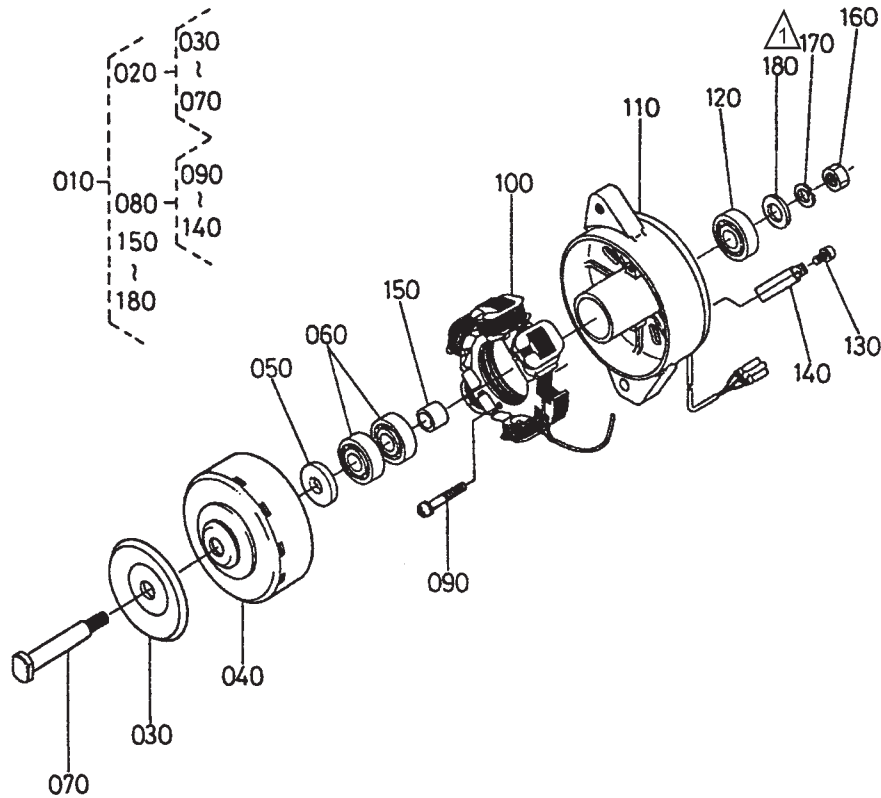

NOTES

- △ ITEMS 170 AND 180, LOCK WASHER AND FLAT WASHER ARE USED ON KUBOTA Z482-EB ENGINE ONLY.

KUBOTA Z482-EB/E2B/E3B ENGINE — DYNAMO ASSY.

DYNAMO ASSY.

<u>NO.</u>	<u>PART NO.</u>	<u>PART NAME</u>	<u>QTY.</u>	<u>REMARKS</u>
010	1753164010	DYNAMO ASSY. , Z482-EB	1	INCLUDES ITEMS W/%
010	1753164012	DYNAMO ASSY. , Z482-E2B/E3B..	1	INCLUDES ITEMS W/#
020	1553164122	COMP. FLYWHEEL, Z482-EB.....	1	INCLUDES ITEMS W/+
020	1553264120	COMP. FLYWHEEL, Z482-E2B/E3B.	1	INCLUDES ITEMS W/<
030%#+<	1553164110	PULLEY	1	
040%+	1553164040	FLYWHEEL	1	Z482-EB
040#<	1553264040	FLYWHEEL	1	Z482-E2B AND Z482-E3B
050%+	6C04082860	COLLAR.....	1	Z482-EB
050#+<	1553164140	COLLAR.....	1	Z482-E2B AND Z482-E3B
060%#+<	1553174180	BEARING, BALL	2	
070%+	1553174140	SHAFT, FAN.....	1	Z482-EB
070#<	1553274140	SHAFT, FAN.....	1	Z482-E2B AND Z482-E3B
080%	1553164363	COMP. STATOR, Z482-EB	1	INCLUDES ITEMS W/>
080#	1553264360	COMP. STATOR, Z482-E2B/E3B ...	1	INCLUDES ITEMS W/\$
090%#>\$	1526193010	SCREW, ROUND HD.	2	
100%#>\$	1553164292	STATOR	1	
110%>	1553164072	PLATE	1	Z482-EB
110#\$	1553264070	PLATE	1	Z482-E2B AND Z482-E3B
120%#>\$	1553174180	BEARING, BALL	1	
130%#>\$	1553193010	SCREW, ROUND HD.	1	
140%#>\$	1553164190	CLAMP, CORD	1	
150%#	1526164150	COLLAR	1	
160%	1526192030	NUT.....	1	Z482-EB AND Z482-E3B
160#	0277160100	NUT, FLANGE.....	1	Z482-E2B
170%	1526194070	WASHER, LOCK.....	1	Z482-EB AND Z482-E3B
180%	1526194020	WASHER, FLAT	1	Z482-EB AND Z482-E3B

KUBOTA Z482-EB/E2B/E3B ENGINE — STARTER ASSY.

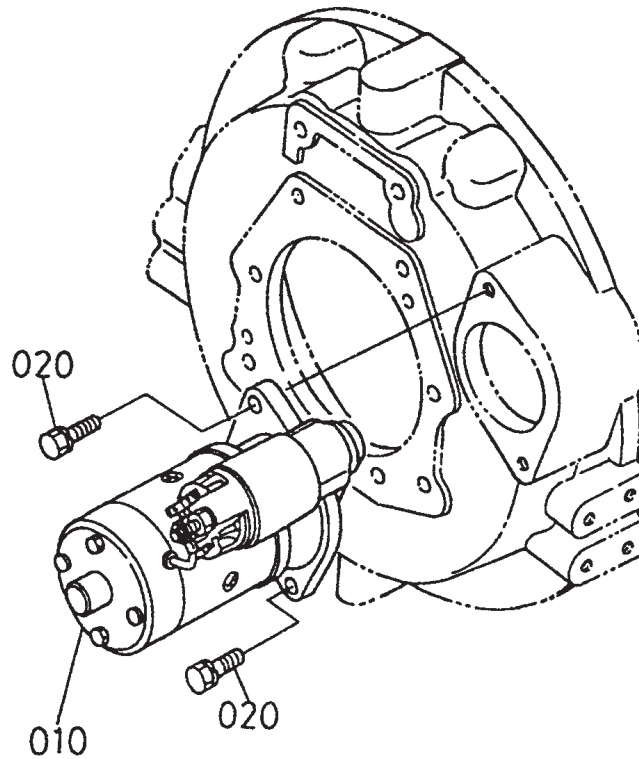

KUBOTA Z482-EB/E2B/E3B ENGINE — STARTER ASSY.

STARTER ASSY.

<u>NO.</u>	<u>PART NO.</u>	<u>PART NAME</u>	<u>QTY.</u>	<u>REMARKS</u>
010	1983763010	STARTER ASSY. 12V, 0.8KW	1	
020	0112350825	BOLT	2	

KUBOTA Z482-EB/E2B/E3B ENGINE — STARTER COMP. ASSY.

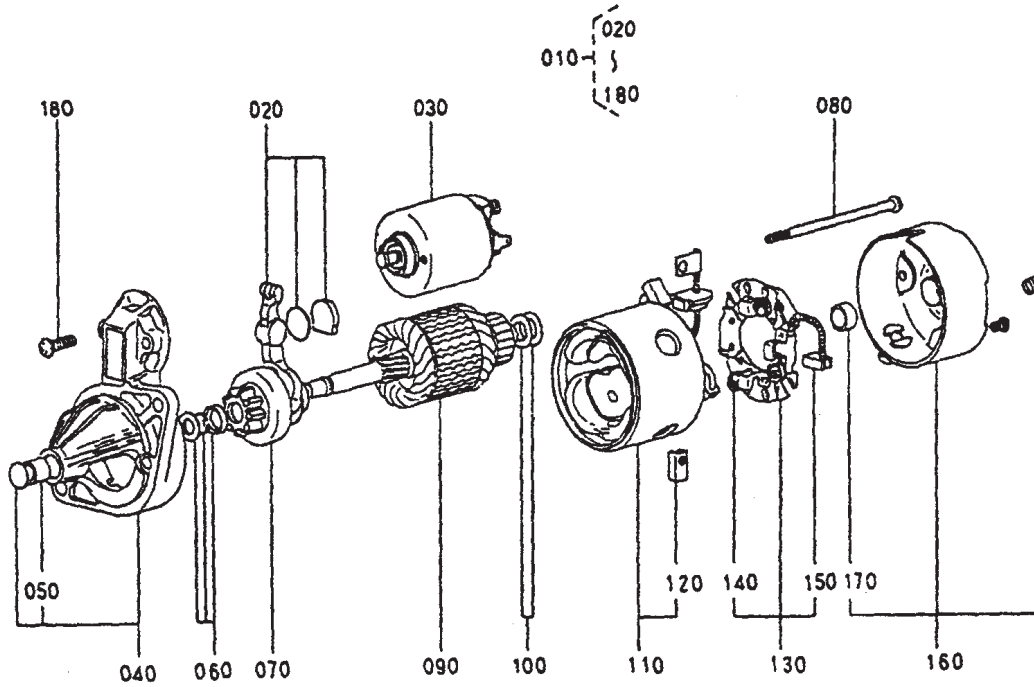

KUBOTA Z482-EB/E2B/E3B ENGINE — STARTER COMP. ASSY.

STARTER COMPONENTS ASSY.

<u>NO.</u>	<u>PART NO.</u>	<u>PART NAME</u>	<u>QTY.</u>	<u>REMARKS</u>
010	1983763010	STARTER ASSY.....	1.....	INCLUDES ITEMS W/@
020@	1983763050	LEVER, DRIVE	1	
030@	1585263020	SWITCH, MAGNETIC	1	
040@	1983763030	FRAME, DRIVE END.....	1.....	INCLUDES ITEMS W/#
050@#	1585263240	BUSH	1	
060@	1983763150	STOPPER	1	
070@	1983763040	CLUTCH, OVER RUNNING	1	
080@	1983763320	BOLT	2	
090@	1983763070	ARMATURE	1	
100@	1585263410	WASHER, ADJUSTING	1	
110@	1983763080	YOKE ASSY.	1.....	INCLUDES ITEMS W/%
120@%	1585263360	BRUSH	2	
130@	1585263380	HOLDER, BRUSH ASSY.....	1.....	INCLUDES ITEMS W/+
140@+	1585263390	SPRING, BRUSH	3	
150@+	1585263370	BRUSH	1	
160@	1983763200	FRAME, END.....	1.....	INCLUDES ITEM W/\$
170@\$	1585263250	BUSH	1	
180@	1585293310	SCREW, PAN-HEAD	1	

KUBOTA Z482-EB ENGINE — OIL SWITCH ASSY.

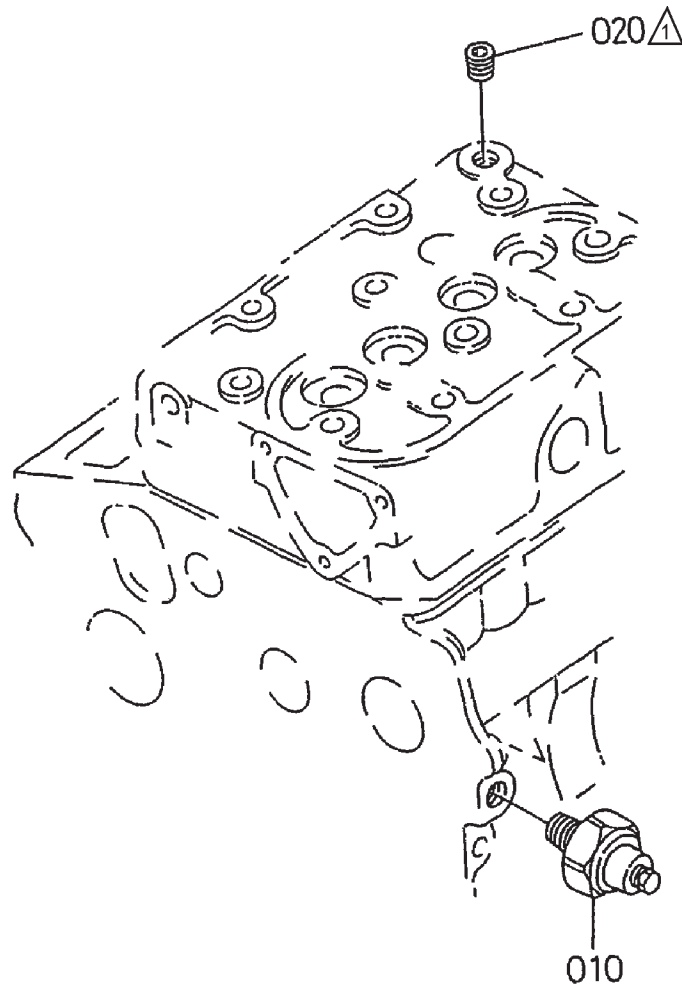

NOTES

- 1  ITEM 020, PLUG IS USED ON KUBOTA Z482-EB ENGINE ONLY.

KUBOTA Z482-EB ENGINE — OIL SWITCH ASSY.

OIL SWITCH ASSY.

<u>NO.</u>	<u>PART NO.</u>	<u>PART NAME</u>	<u>QTY.</u>	<u>REMARKS</u>
010	1584139010	SWITCH, OIL	1.....	Z482-EB
010	1584139013	SWITCH, OIL	1.....	Z482-E2B AND Z482-E3B
020	1584196020	PLUG	1.....	Z482-E2B AND Z482-E3B

KUBOTA Z482-EB/E2B/E3B ENGINE — WATER FLANGE & THERM. ASSY.

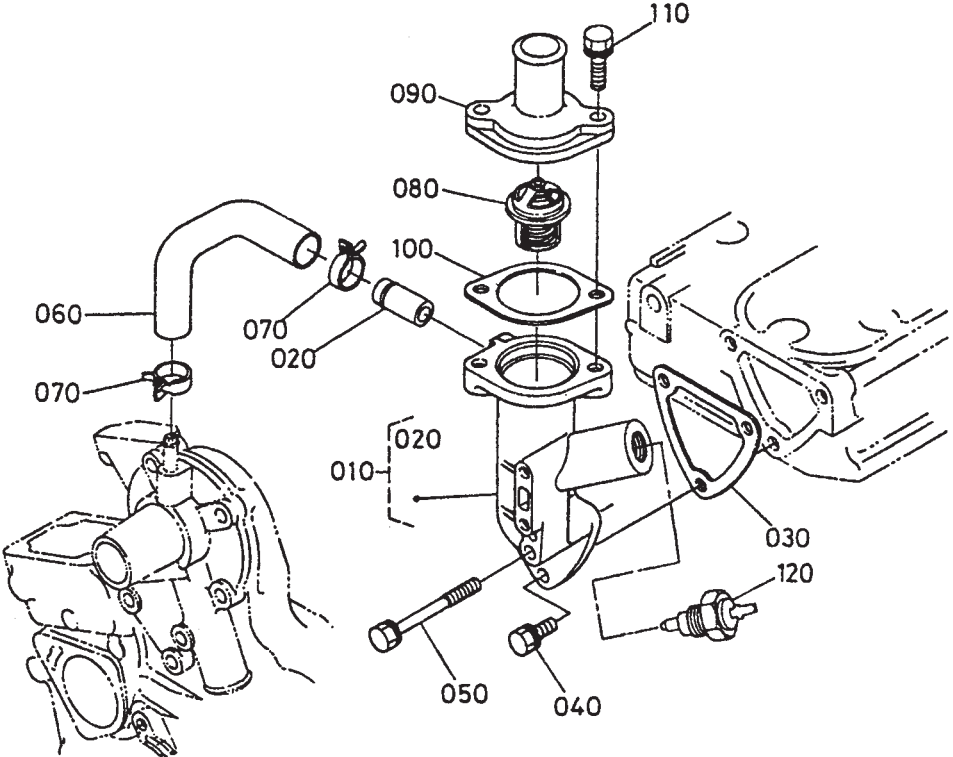

KUBOTA Z482-EB/E2B/E3B ENGINE — WATER FLANGE & THERM. ASSY.

WATER FLANGE AND THERMOSTAT ASSY.

<u>NO.</u>	<u>PART NO.</u>	<u>PART NAME</u>	<u>QTY.</u>	<u>REMARKS</u>
010	1687572700	COMP. FLANGE, WATER, Z482-EB	1.....	INCLUDES ITEMS W/%
010	1687572704	COMP. FLANGE, WATER, Z482-E2B/E3B	1.....	INCLUDES ITEMS W/#
020%#	1624173370	PIPE, WATER RETURN	1	
030	1584172922	GASKET, WATER FLANGE	1.....	Z482-EB
030	1584172923	GASKET, WATER FLANGE	1.....	Z482-E2B AND Z482-E3B
040	0102350616	BOLT	2	
050	0102360650	BOLT	4	
060	1685173350	PIPE, WATER RETURN	1	
070	1624173360	BAND, PIPE	2	
080	1553173010	THERMOSTAT ASSY.	1	
090	1584173260	COVER, THERMOSTAT	1	
100	1685173270	GASKET, THERMOSTAT	1	
110	0102350622	BOLT	2	
120	1554383040	SWITCH, THERMOMETER.....	1.....	Z482-EB
120	1753883040	SWITCH, THERMOMETER.....	1.....	Z482-E2B AND Z482-E3B

KUBOTA Z482-EB/E2B/E3B ENGINE — WATER PUMP ASSY.

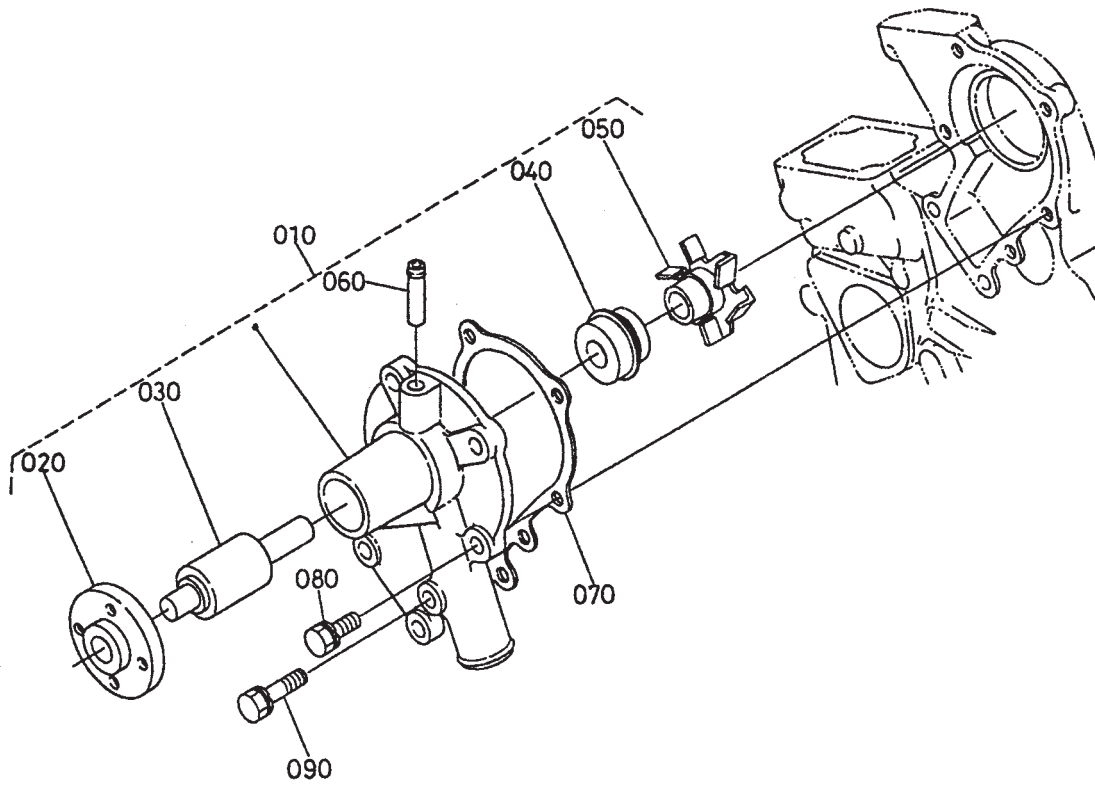

KUBOTA Z482-EB/E2B/E3B ENGINE — WATER PUMP ASSY.

WATER PUMP ASSY.

<u>NO.</u>	<u>PART NO.</u>	<u>PART NAME</u>	<u>QTY.</u>	<u>REMARKS</u>
010	1988373030	WATER PUMP ASSY.....	1.....	INCLUDES ITEMS W/@
020@	1585273520	FLANGE, WATER PUMP	1	
030@	1585273550	BEARING	1	
040@	1548173050	SEAL ASSY., MECHANICAL	1	
050@	1988373510	IMPELLER, WATER PUMP.....	1.....	Z482-EB AND Z482-E2B ONLY
060@	1585273340	PIPE, WATER RETURN	1	
070	1588173432	GASKET, WATER PUMP NA.....	1.....	Z482-EB AND Z482-E2B
070	1687173430	GASKET, WATER PUMP NA.....	1.....	Z482-E3B
080	0102350622	BOLT	4	
090	0102350638	BOLT	1	

KUBOTA Z482-EB/E2B/E3B ENGINE — WATER PIPE ASSY.

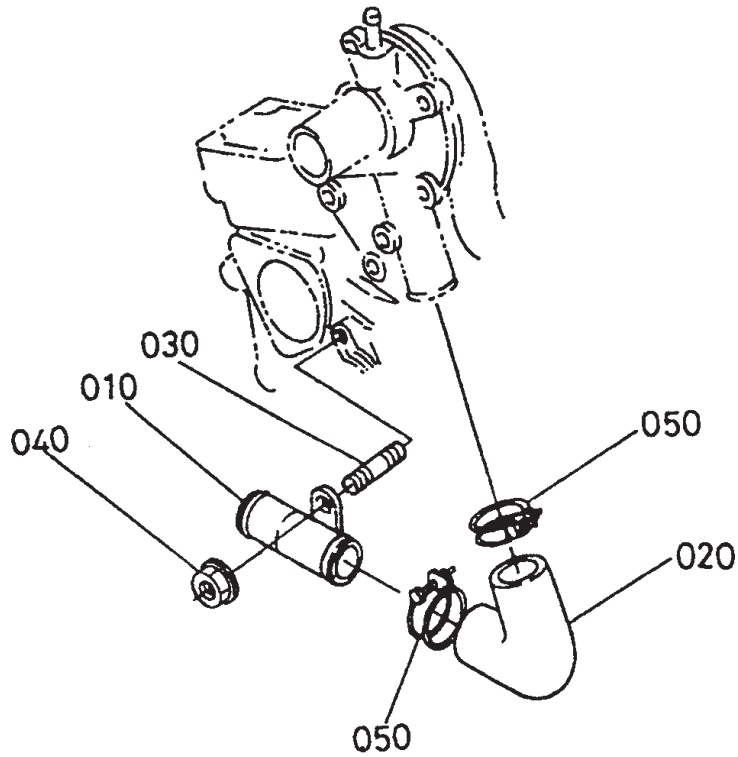

KUBOTA Z482-EB/E2B/E3B ENGINE — WATER PIPE ASSY.

WATER PIPE ASSY.

<u>NO.</u>	<u>PART NO.</u>	<u>PART NAME</u>	<u>QTY.</u>	<u>REMARKS</u>
010	1584172860	PIPE, WATER	1	
020	1588172870	PIPE, WATER	1	
030	1584191510	STUD	1	
040	0275150060	NUT, FLANGE	1	
050	0931889030	CLAMP, HOSE	2.....	Z482-EB
050	1584172960	BAND, PIPE	2.....	Z482-E2B AND Z482-E3B

KUBOTA Z482-EB/E2B/E3B ENGINE — FAN ASSY.

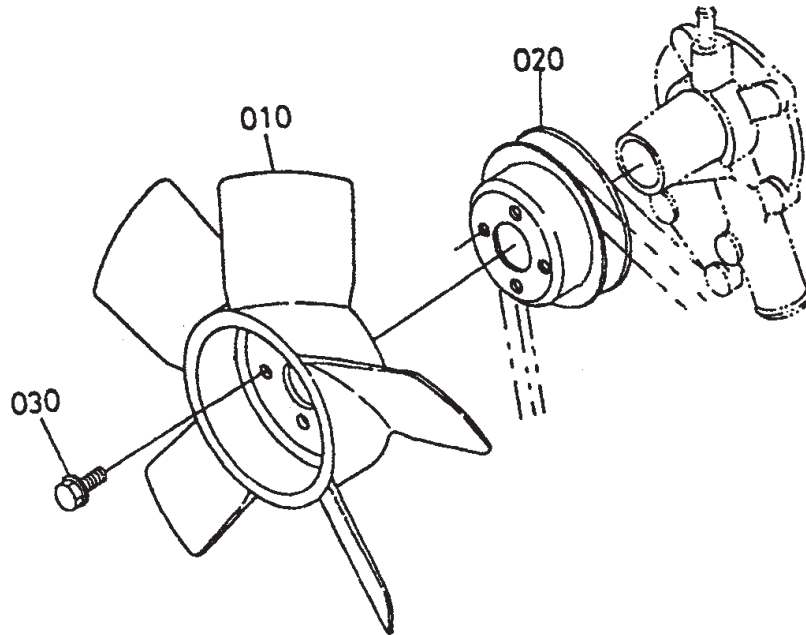

KUBOTA Z482-EB/E2B/E3B ENGINE — FAN ASSY.

FAN ASSY.

<u>NO.</u>	<u>PART NO.</u>	<u>PART NAME</u>	<u>QTY.</u>	<u>REMARKS</u>
010	1586774112	FAN	1	
020	1584174250	PULLEY, FAN	1	
030	0175450610	BOLT, FLANGE	4	

KUBOTA Z482-EB/E2B/E3B ENG. — VALVE AND ROCKER ARM ASSY.

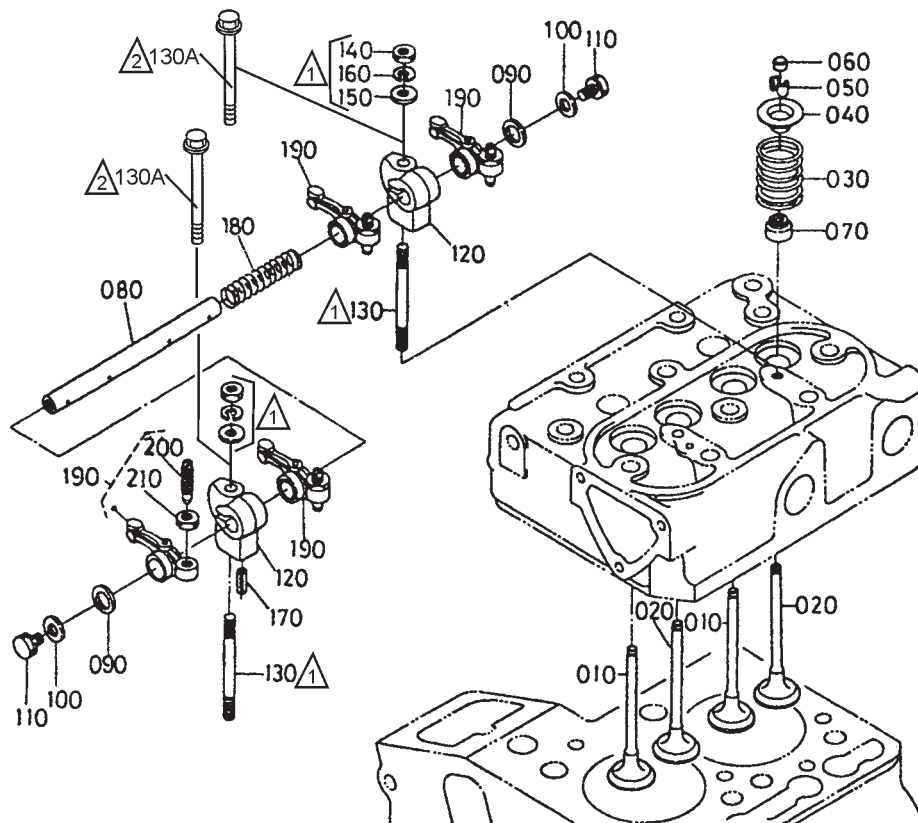

NOTES

△¹ ITEMS 130, 140 160 AND 150, (STUD, NUT, FLAT WASHER AND LOCK WASHER ARE USED ON KUBOTA Z482-EB ENGINE ONLY.

△² ITEM 130A (FLANGE BOLT) IS USED ON KUBOTA Z482-E2B AND Z482-E3B ENGINES ONLY.

KUBOTA Z482-EB/E2B/E3B ENG. — VALVE AND ROCKER ARM ASSY.

VALVE AND ROCKER ARM ASSY.

<u>NO.</u>	<u>PART NO.</u>	<u>PART NAME</u>	<u>QTY.</u>	<u>REMARKS</u>
010	1460113110	VALVE, INLET	2	
020	1460113120	VALVE, EXHAUST	2	
030	1460113240	SPRING, VALVE	4	
040	1460113330	RETAINER, SPRING	4	
050	1460113360	COLLET, VALVE SPRING SET	4	
060	1685113280	CAP, VALVE	4	
070	1584113150	SEAL, VALVE STEM	4	
080	1584114263	SHAFT, ROCKER ARM	1.....	Z482-EB AND Z482-E2B
080	1584114264	SHAFT, ROCKER ARM	1.....	Z482-E3B
090	1687114430	WASHER	2	
100	1584194022	WASHER, FLAT	2	
110	0102350610	BOLT	2	
120	1584114350	BRACKET, ROCKER ARM	2.....	Z482-EB
120	1G95814350	BRACKET, ROCKER ARM	2.....	Z482-E2B AND Z482-E3B
130	1460114410	STUD	2.....	Z482-EB
130A	0175450640	BOLT FLANGE.....	2.....	Z482-E2B AND Z482-E3B
140	0205650060	NUT.....	2.....	Z482-EB ONLY
150	0401250060	WASHER, FLAT	2.....	Z482-EB ONLY
160	0451260060	WASHER, LOCK.....	2.....	Z482-EB ONLY
170	0541100420	PIN, SPRING	1	
180	1460114310	SPRING, ROCKER ARM.....	1.....	Z482-EB AND Z482-E2B
180	1460114312	SPRING, ROCKER ARM.....	1.....	Z482-E3B
190	1584114030	ROCKER ARM ASSY.....	4.....	INCLUDES ITEMS W/#
200#	1584114230	SCREW, ADJUSTING	4	
210#	1460114240	NUT	4	

KUBOTA Z482-EB/E2B/E3B ENGINE — INLET MANIFOLD ASSY.

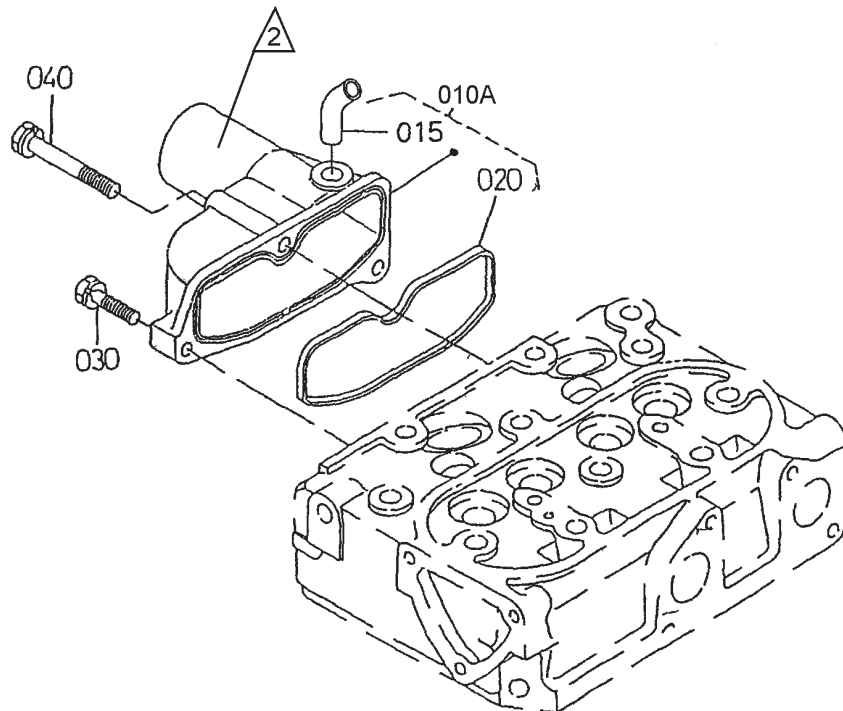
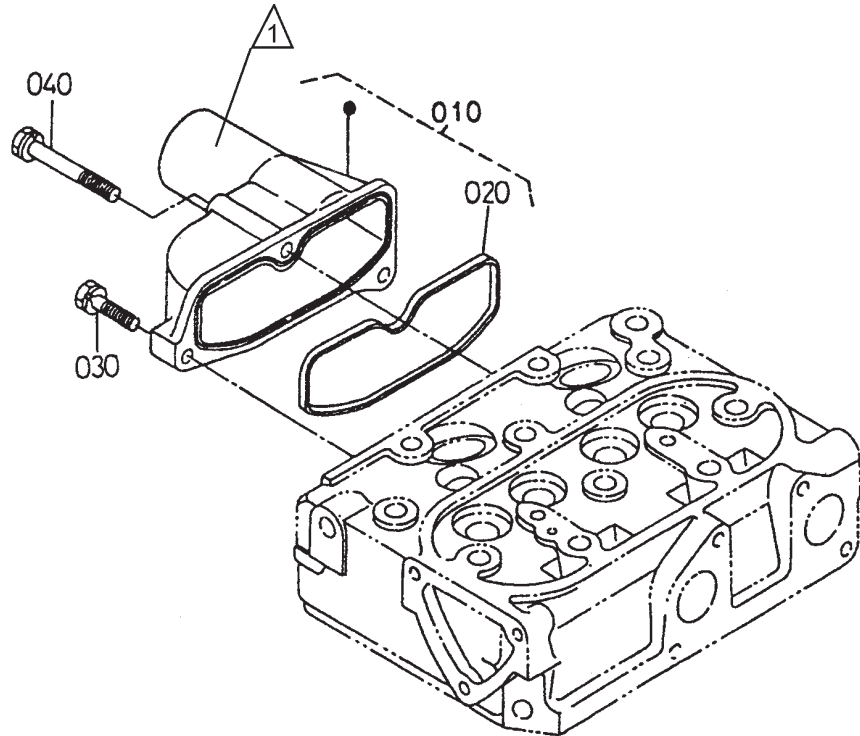

NOTES

 ITEM 010 (MANIFOLD INLET ASSY.) IS USED ON KUBOTA Z482-EB ENGINE ONLY.

 ITEM 010A (MANIFOLD INLET ASSY.) IS USED ON KUBOTA Z482-E2B AND Z482-E3B ENGINES ONLY.

KUBOTA Z482-EB/E2B/E3B ENGINE — INLET MANIFOLD ASSY.

INLET MANIFOLD ASSY.

<u>NO.</u>	<u>PART NO.</u>	<u>PART NAME</u>	<u>QTY.</u>	<u>REMARKS</u>
010	1584111770	MANIFOLD, INLET ASSY., Z482-EB	1.....	INCLUDES ITEMS W/%
010A	1G95711771	MANIFOLD, INLET ASSY., Z482-E2B/E3B	1.....	INCLUDES ITEMS W/#
015#	1G96005550	PIPE BREATHER.....	1.....	Z482-E2B AND Z482-E3B
020%#	1584111820	GASKET, IN-MANIFOLD	1	
030	0102350618	BOLT	2	
040	0102350645	BOLT	1	

KUBOTA Z482-EB/E2B/E3B ENGINE — EXHAUST MANIFOLD ASSY.

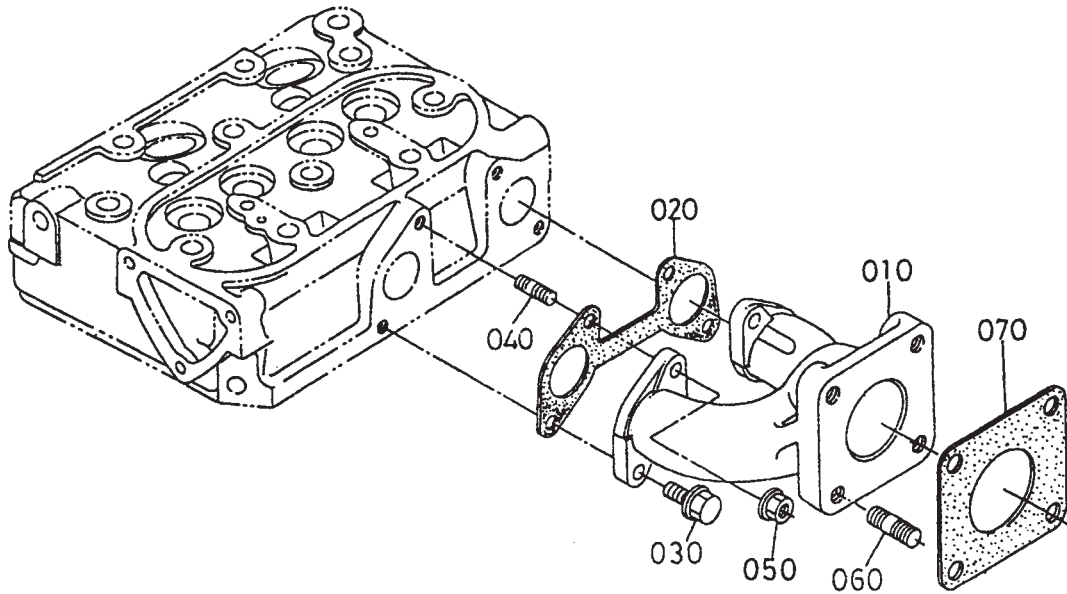

KUBOTA Z482-EB/E2B/E3B ENGINE — EXHAUST MANIFOLD ASSY.

EXHAUST MANIFOLD ASSY.

<u>NO.</u>	<u>PART NO.</u>	<u>PART NAME</u>	<u>QTY.</u>	<u>REMARKS</u>
010	1584112313	MANIFOLD, EXHAUST	1	
020	1584112360	GASKET	1	
030	0175950616	BOLT, UBS	2	
040	0151350618	STUD	2	
050	0275650060	NUT, UBS	2	
060	0151350822	STUD	4	
070	1526312370	GASKET, MUFFLER	1	

KUBOTA Z482-EB/E2B/E3B ENG. — GLOW PLUG/LAMP AND TIMER ASSY.

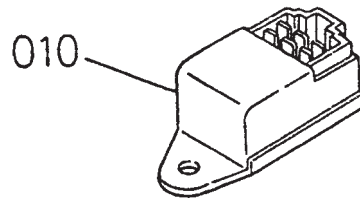

KUBOTA Z482-EB/E2B/E3B ENG. — GLOW PLUG/LAMP AND TIMER ASSY.

GLOW PLUG/LAMP AND TIMER ASSY.

<u>NO.</u>	<u>PART NO.</u>	<u>PART NAME</u>	<u>QTY.</u>	<u>REMARKS</u>
010	1569465990	TIMER, GLOW LAMP	1	

KUBOTA Z482-EB/E2B/E3B ENGINE — STARTER SWITCH ASSY.

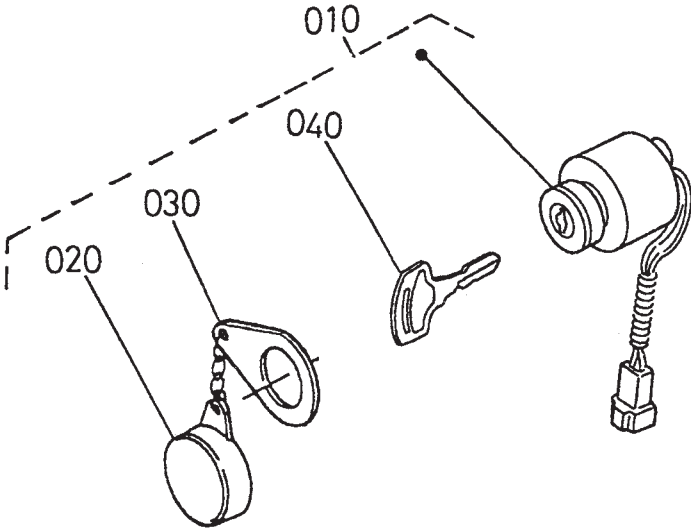

KUBOTA Z482-EB/E2B/E3B ENGINE — STARTER SWITCH ASSY.

STARTER SWITCH ASSY.

<u>NO.</u>	<u>PART NO.</u>	<u>PART NAME</u>	<u>QTY.</u>	<u>REMARKS</u>
010	3741059110	STARTER SWITCH ASSY.....	1.....	INCLUDES ITEMS W/%
020%	3741055180	CAP, STARTER SWITCH	1	
030%	6641655170	WASHER	1	
040%	3741055150	KEY, STARTER	1	

KUBOTA Z482-EB/E2B/E3B ENGINE — AIR CLEANER ASSY.

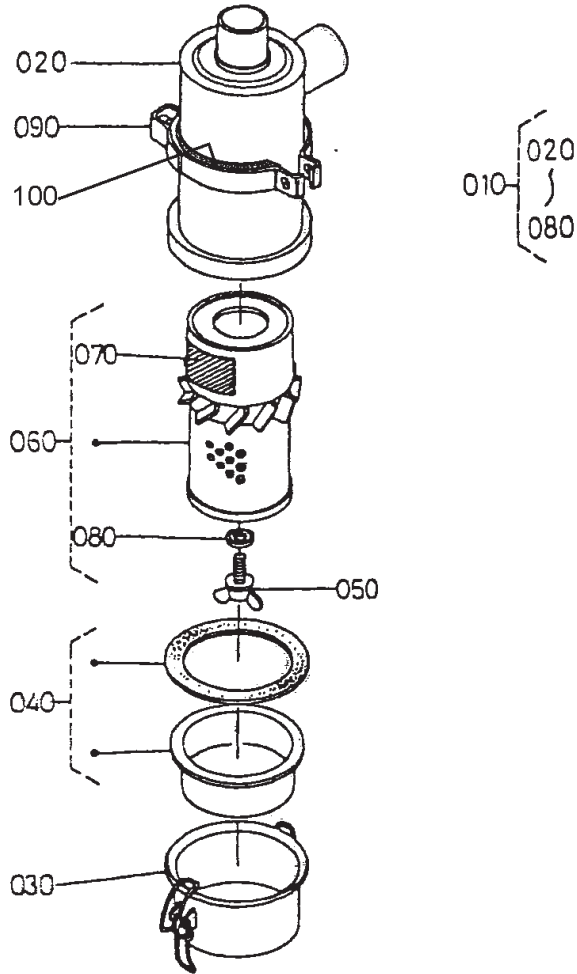

KUBOTA Z482-EB/E2B/E3B ENGINE — AIR CLEANER ASSY.

AIR CLEANER ASSY.

<u>NO.</u>	<u>PART NO.</u>	<u>PART NAME</u>	<u>QTY.</u>	<u>REMARKS</u>
010	1556211010	AIR CLEANER ASSY.....	1.....	INCLUDES ITEMS W/@
020@	155451115	BODY, AIR CLEANER	1	
030@	1558911160	COVER, AIR CLEANER	1	
040@	1522111410	COVER, BAFFLE	1	
050@	1522192620	BOLT, WING	1	
060@	1556211080	ELEMENT, AIR CLEANER ASSY.	1.....	INCLUDES ITEMS W/#
070@#	1522787480	LABEL, ELEMENT A/C	1	
080@#	1522194430	WASHER, WITH RUBBER	1	
090	3415013960	BAND, AIR CLEANER	1	
100	3415013970	CUSHION	1.....	Z482-EB ONLY

KUBOTA Z482-EB/E2B/E3B ENGINE — ACCESSORIES

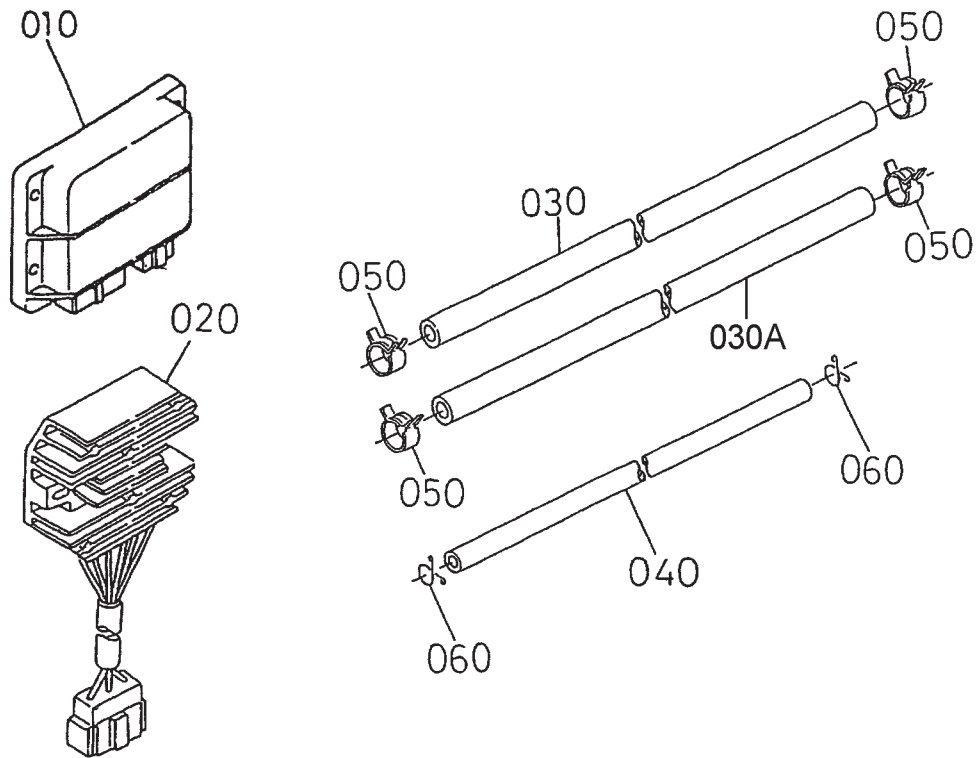

KUBOTA Z482-EB/E2B/E3B ENGINE — ACCESSORIES

ACCESSORIES

<u>NO.</u>	<u>PART NO.</u>	<u>PART NAME</u>	<u>QTY.</u>	<u>REMARKS</u>
010	1747260604	EMERGENCY UNIT	1	
020	1584464600	COMP. REGULATOR	1.....	REPLACES P/N 1518164602
030	0966180400	TUBE FUEL. 8X13X400L	1	
030A	0966180240	TUBE FUEL. 8X13X240L	1	
040	0966140320	TUBE FUEL. 4X8X320L	1	
050	1491142750	CLIP, PIPE	4	
060	1497142750	CLIP, PIPE	6	

KUBOTA Z482-EB/E2B/E3B ENGINE — PISTON KIT (OPTION)

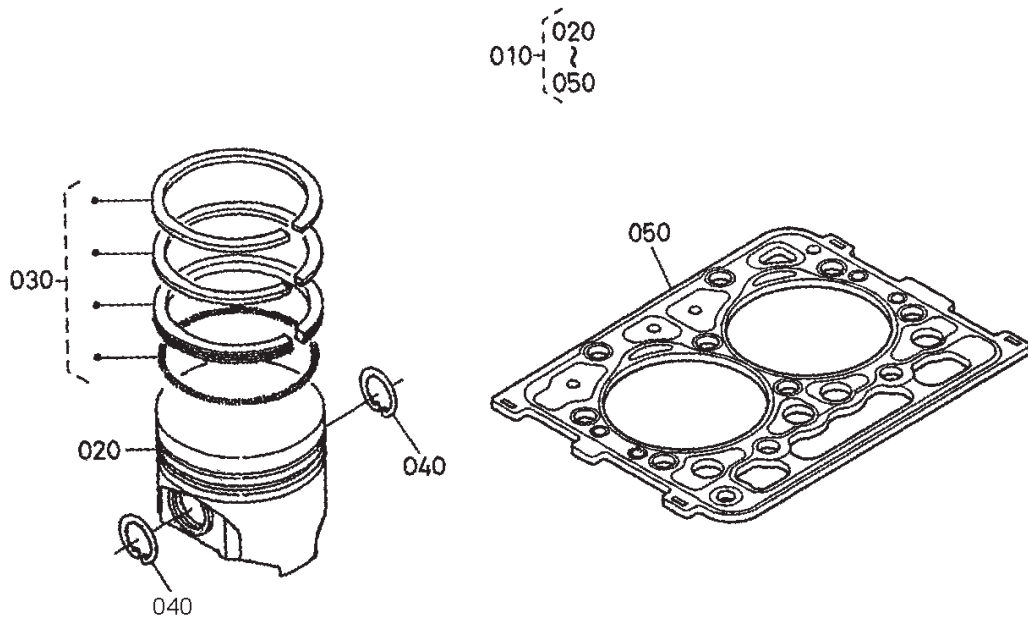

KUBOTA Z482-EB/E2B/E3B ENGINE — PISTON KIT (OPTION)

PISTON KIT (OPTION)

<u>NO.</u>	<u>PART NO.</u>	<u>PART NAME</u>	<u>QTY.</u>	<u>REMARKS</u>
010	1685321002	KIT, PISTON, Z482-E2B/E3B.....	1.....	INCLUDES ITEMS W/%
020%	1685121114	PISTON	1	
030%	1685321050	ASSY. PISTON RING	1	
040%	1526121330	CIRCULAR CLIP PISTON PIN	1	
050%	1685103312	GASKET, CYLINDER HEAD	1	

TERMS AND CONDITIONS OF SALE — PARTS

PAYMENT TERMS

Terms of payment for parts are net 30 days.

FREIGHT POLICY

All parts orders will be shipped collect or prepaid with the charges added to the invoice. All shipments are F.O.B. point of origin. Multiquip's responsibility ceases when a signed manifest has been obtained from the carrier, and any claim for shortage or damage must be settled between the consignee and the carrier.

MINIMUM ORDER

The minimum charge for orders from Multiquip is \$15.00 net. Customers will be asked for instructions regarding handling of orders not meeting this requirement.

RETURNED GOODS POLICY

Return shipments will be accepted and credit will be allowed, subject to the following provisions:

1. A Returned Material Authorization must be approved by Multiquip prior to shipment.
2. To obtain a Return Material Authorization, a list must be provided to Multiquip Parts Sales that defines item numbers, quantities, and descriptions of the items to be returned.
 - a. The parts numbers and descriptions must match the current parts price list.
 - b. The list must be typed or computer generated.
 - c. The list must state the reason(s) for the return.
 - d. The list must reference the sales order(s) or invoice(s) under which the items were originally purchased.
 - e. The list must include the name and phone number of the person requesting the RMA.
3. A copy of the Return Material Authorization must accompany the return shipment.
4. Freight is at the sender's expense. All parts must be returned freight prepaid to Multiquip's designated receiving point.

5. Parts must be in new and resalable condition, in the original Multiquip package (if any), and with Multiquip part numbers clearly marked.
6. The following items are not returnable:
 - a. Obsolete parts. (If an item is in the price book and shows as being replaced by another item, it is obsolete.)
 - b. Any parts with a limited shelf life (such as gaskets, seals, "O" rings, and other rubber parts) that were purchased more than six months prior to the return date.
 - c. Any line item with an extended dealer net price of less than \$5.00.
 - d. Special order items.
 - e. Electrical components.
 - f. Paint, chemicals, and lubricants.
 - g. Decals and paper products.
 - h. Items purchased in kits.
7. The sender will be notified of any material received that is not acceptable.
8. Such material will be held for five working days from notification, pending instructions. If a reply is not received within five days, the material will be returned to the sender at his expense.
9. Credit on returned parts will be issued at dealer net price at time of the original purchase, less a 15% restocking charge.
10. In cases where an item is accepted, for which the original purchase document can not be determined, the price will be based on the list price that was effective twelve months prior to the RMA date.
11. Credit issued will be applied to future purchases only.

PRICING AND REBATES

Prices are subject to change without prior notice. Price changes are effective on a specific date and all orders received on or after that date will be billed at the revised price. Rebates for price declines and added charges for price increases will not be made for stock on hand at the time of any price change.

Multiquip reserves the right to quote and sell direct to Government agencies, and to Original Equipment Manufacturer accounts who use our products as integral parts of their own products.

SPECIAL EXPEDITING SERVICE

A \$35.00 surcharge will be added to the invoice for special handling including bus shipments, insured parcel post or in cases where Multiquip must personally deliver the parts to the carrier.

LIMITATIONS OF SELLER'S LIABILITY

Multiquip shall not be liable hereunder for damages in excess of the purchase price of the item with respect to which damages are claimed, and in no event shall Multiquip be liable for loss of profit or good will or for any other special, consequential or incidental damages.

LIMITATION OF WARRANTIES

No warranties, express or implied, are made in connection with the sale of parts or trade accessories nor as to any engine not manufactured by Multiquip. Such warranties made in connection with the sale of new, complete units are made exclusively by a statement of warranty packaged with such units, and Multiquip neither assumes nor authorizes any person to assume for it any other obligation or liability whatever in connection with the sale of its products. Apart from such written statement of warranty, there are no warranties, express, implied or statutory, which extend beyond the description of the products on the face hereof.

Effective: February 22, 2006

OPERATION AND PARTS MANUAL

HERE'S HOW TO GET HELP

PLEASE HAVE THE MODEL AND SERIAL
NUMBER ON-HAND WHEN CALLING

UNITED STATES

Multiquip Corporate Office

18910 Wilmington Ave.
Carson, CA 90746
Contact: mq@multiquip.com

Tel. (800) 421-1244
Fax (800) 537-3927

Service Department

800-421-1244
310-537-3700

Fax: 310-537-4259

Technical Assistance

800-478-1244

Fax: 310-943-2238

MQ Parts Department

800-427-1244
310-537-3700

Fax: 800-672-7877
Fax: 310-637-3284

Warranty Department

800-421-1244
310-537-3700

Fax: 310-943-2249

MEXICO

MQ Cipsa

Carr. Fed. Mexico-Puebla KM 126.5
Momoxpan, Cholula, Puebla 72760 Mexico
Contact: pmastretta@cipsa.com.mx

Tel: (52) 222-225-9900
Fax: (52) 222-285-0420

CANADA

Multiquip

4110 Industriel Boul.
Laval, Quebec, Canada H7L 6V3
Contact: jmartin@multiquip.com

Tel: (450) 625-2244
Tel: (877) 963-4411
Fax: (450) 625-8664

UNITED KINGDOM

Multiquip (UK) Limited Head Office

Unit 2, Northpoint Industrial Estate,
Globe Lane,
Dukinfield, Cheshire SK16 4UJ
Contact: sales@multiquip.co.uk

Tel: 0161 339 2223
Fax: 0161 339 3226

© COPYRIGHT 2011, MULTIQUIP INC.

Multiquip Inc and the MQ logo are registered trademarks of Multiquip Inc. and may not be used, reproduced, or altered without written permission. All other trademarks are the property of their respective owners and used with permission.

This manual MUST accompany the equipment at all times. This manual is considered a permanent part of the equipment and should remain with the unit if resold.

The information and specifications included in this publication were in effect at the time of approval for printing. Illustrations, descriptions, references and technical data contained in this manual are for guidance only and may not be considered as binding. Multiquip Inc. reserves the right to discontinue or change specifications, design or the information published in this publication at any time without notice and without incurring any obligations.

Your Local Dealer is:



Free Manuals Download Website

<http://myh66.com>

<http://usermanuals.us>

<http://www.somanuals.com>

<http://www.4manuals.cc>

<http://www.manual-lib.com>

<http://www.404manual.com>

<http://www.luxmanual.com>

<http://aubethermostatmanual.com>

Golf course search by state

<http://golfingnear.com>

Email search by domain

<http://emailbydomain.com>

Auto manuals search

<http://auto.somanuals.com>

TV manuals search

<http://tv.somanuals.com>