

OPERATION AND PARTS MANUAL



ULTRA-SILENT™ SERIES MODEL DCA-125USJ 50 Hz GENERATOR

PARTS LIST NO. M3870400004

Revision #0 (03/11/05)

**THIS MANUAL MUST ACCOMPANY
THE EQUIPMENT AT ALL TIMES.**



WARNING



CALIFORNIA — Proposition 65 Warning

Diesel engine exhaust and some of its constituents are known to the State of California to cause cancer, birth defects and other reproductive harm.

HERE'S HOW TO GET HELP

PLEASE HAVE THE MODEL AND SERIAL
NUMBER *ON-HAND* WHEN CALLING

MQ POWER CORPORATE OFFICE

18910 Wilmington Ave. 800-421-1244
Carson, CA 90746 FAX:310-632-2656
Email: mqpower@multiquip.com
Internet: www.mqpower.com

PARTS DEPARTMENT

800-427-1244 FAX:800-672-7877
310-537-3700 FAX:310-637-3284

SERVICE DEPARTMENT

800-835-2551 FAX:310-638-8046
310-537-3700

TECHNICAL ASSISTANCE

800-478-1244 FAX:310-631-5032

WARRANTY DEPARTMENT

800-835-2551, EXT.279 FAX:310-638-8046
310-537-3700, EXT.279

© COPYRIGHT 2005, MULTIQUIP INC.

MQ Power Inc, Ultra-Silent series, and the MQ Power logo are registered trademarks of Multiquip Inc. and may not be used, reproduced, or altered without written permission. All other trademarks are the property of thier respective owners and used with permission.

This manual **MUST** accompany the equipment at all times. This manual is considered a permanent part of the equipment and should remain with the unit if resold.

The information and specifications included in this publication were in effect at the time of approval for printing. Illustrations are based on the *DCA-125USJ (50 HZ) Ultra Silent Generator*. Multiquip Inc. reserves the right to discontinue or change specifications, design or the information published in this publication at any time without notice and without incurring any obligations.

**To find the latest revision of this
publication, visit our website at:
www.mqpower.com**



**MQ POWER DCA12USJ
AC GENERATOR**

California Proposition 65 Warning 2
 Here's How To Get Help 3
 Table Of Contents 4
 Parts Ordering Procedures 5
 Specifications 6
 Dimensions (Top, Side, Front) 7
 Safety Message Alert Symbols 8-9
 Rules for Safe Operation 10-13
 Installation 14-15
 Towing Safety Precaution 16
 Trailer Specifications 17
 Generator Decals 18-19
 General Information 20
 Major Components 21
 Generator Control Panel 23
 Engine Operating Panel 24-25
 Output Terminal Panel Familiarization 26-28
 Load Application 29
 Generator Outputs 30-31
 Gauge Reading 31
 Output Terminal Panel Connections 32-33
 Pre Setup 34-37
 Generator Start-up Procedure (Manual) 38-40
 Generator Start-up Procedure (Auto Mode) 41
 Generator Shut-Down Procedure 42
 Maintenance 43-45
 Trailer Brakes Maintenance 46
 Trailer Maintenance 47-48
 Trailer Wiring Diagram 49
 Generator Wiring Diagram 50
 Engine Wiring Diagram 51
 Generator Troubleshooting 52
 Engine Controller Troubleshooting 53
 Explanation of Code in Remarks Column 54
 Suggested Spare Parts 55

COMPONENT DRAWINGS

Generator Assembly 56-57
 Control Box Assembly 58-61
 Engine & Radiator Assembly 62-65
 Output Terminal Assembly 66-67
 Battery Assembly 68-69
 Muffler Assembly 70-71
 Fuel Tank Assembly 72-73
 Enclosure #1 Assembly 74-77
 Enclosure #2 Assembly 78-79
 Rubber Seals Assembly 80-81
 Nameplate and Decals 82-83
 Terms and Condition of Sale — Parts 84

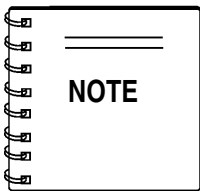

Specification and part number are subject to change without notice.

PARTS ORDERING PROCEDURES

When ordering parts, please supply the following information:

- Dealer account number
- Dealer name and address
- Shipping address (if different than billing address)
- Return fax number
- Applicable model number
- Quantity, part number and description of each part
- Specify preferred method of shipment:
 - ✓ FedEx or UPS Ground
 - ✓ FedEx or UPS Second Day or Third Day
 - ✓ FedEx or UPS Next Day
 - ✓ Federal Express Priority One
 - ✓ DHL
 - ✓ Truck

Note: Unless otherwise indicated by customer, all orders are treated as "Standard Orders", and will ship within 24 hours. We will make every effort to ship "Air Shipments" the same day that the order is received, if prior to 2PM west coast time. "Stock Orders" must be so noted on fax or web forms.



Here's how to get help...

Please have the model and serial number on hand when calling.

MQ POWER CORPORATE OFFICE

18910 Wilmington Ave. 800-421-1244
 Carson, CA 90746 FAX: 310-632-2656
 Email: mqpower@multiquip.com
 Internet: www.mqpower.com

PARTS DEPARTMENT

800-427-1244 FAX: 800-672-7877
 310-537-3700 FAX: 310-637-3284

SERVICE DEPARTMENT

800-835-2551 FAX: 310-638-8046
 310-537-3700

TECHNICAL ASSISTANCE

800-478-1244 FAX: 310-631-5032

WARRANTY DEPARTMENT

800-835-2551, EXT. 279 FAX: 310-638-8046
 310-537-3700, EXT. 279

Place Your Parts Order Via Web or Fax For Even More Savings!

(Domestic USA Dealers Only)

Extra Discounts!

All parts orders which include complete part numbers and are received by our automated web parts order system, or by fax qualify for the following extra discounts:

Ordered via	Standard orders	Stock orders (\$750 list and above)
Fax	3%	10%
Web	5%	10%

Special freight allowances when you order 10 or more line items via Web or Fax! **

FedEx Ground Service *at no charge for freight*

No other allowances on freight shipped by any other carrier.

***Common nuts, bolts and washers (all items under \$1.00 list price) do not count towards the 10+ line items.*

NOTE: DISCOUNTS ARE SUBJECT TO CHANGE



MQPOWER
 A Division of Multiquip Inc.
 POST OFFICE BOX 6254
 CARSON, CA 90749
 310-537-3700 • 800-421-1244
 FAX: 310-632-2656
 E-MAIL: mqpower@multiquip.com
 INTERNET: www.mqpower.com

Direct TOLL-FREE access to our Parts Department:

Toll-free nationwide — 800-427-1244

Toll-free FAX — 800-6-PARTS-7 (800/672-7877)

DCA-125USJ (50 HZ)— SPECIFICATIONS

Table 1. Generator Specifications		
Model	DCA125USJ	
Type	Revolving field, self ventilated, open protected type synchronous generator	
Armature Connection	Star with Neutral	Zig Zag
Phase	3	Single
Standby Output	110 KVA (88 KW)	63 KW
Prime Output	100 KVA (80 KW)	58 KW
Voltage	200V or 400V	200/100V
Frequency	50 Hz	
Speed	1500 rpm	
Power Factor	0.8	1
Aux. AC Power	Single Phase, 50 Hz	
Voltage	100 V	
Output	4.8 KW (2.4 KW x 2)	

Table 2. Engine Specifications		
Model	JOHN DEERE 6068TF 275	
Type	4 cycle, water-cooled, direct injection, turbo-charged	
No. of Cylinders	6 cylinders	
Bore x Stroke	4.19 in. x 5 in. (106 mm x 127 mm)	
Rated Output	150 HP/1500 rpm	
Displacement	415 cu. in. (6,800 cc)	
Starting	Electric 12VDC	
Coolant Capacity	4.4 gal. (16.8 liters)	
Lube Oil Capacity	5.3 gal. (18.9 liters)	
Fuel Type	#2 Diesel Fuel	
Fuel Tank Capacity	169 gal. (640 liters)	
Fuel Consumption	6.1 gal. (23.2 L)/hr at full load	4.6 gal. (17.5 L)/hr at 3/4 load
	3.0 gal. (11.3 L)/hr at 1/2 load	2.0 gal. (7.5 L)/hr at 1/4 load
Battery	12V BCI Group 46	

DCA-125USJ (50 HZ)— DIMENSIONS (TOP, SIDE AND FRONT)

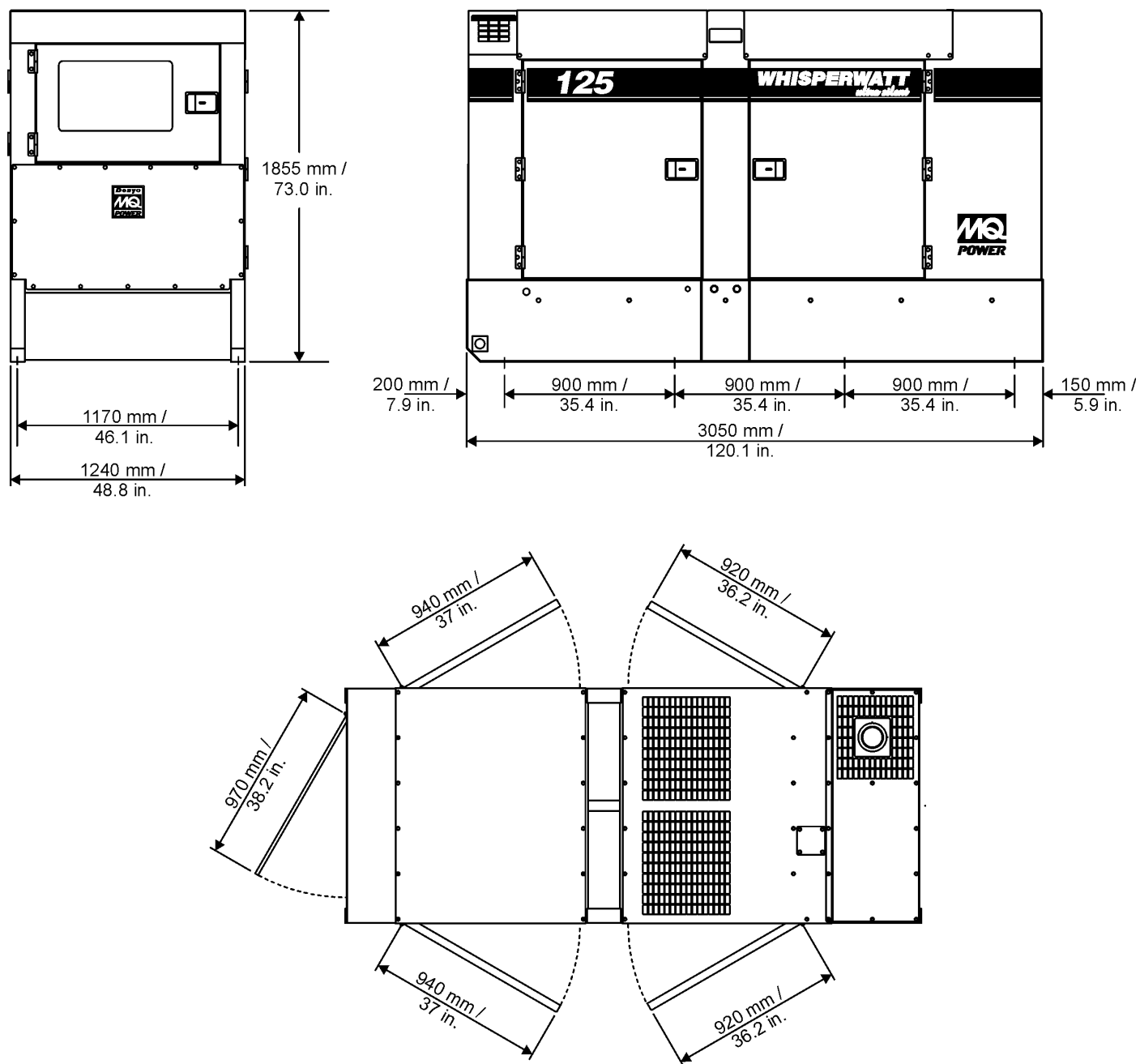
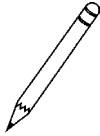
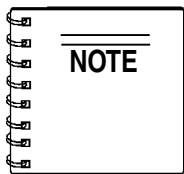

Figure 1. Dimensions

DCA-125USJ (50 HZ) — SAFETY MESSAGE ALERT SYMBOLS

FOR YOUR SAFETY AND THE SAFETY OF OTHERS!

Safety precautions should be followed at all times when operating this equipment. Failure to read and understand the Safety Messages and Operating Instructions could result in injury to yourself and others.



This Owner's Manual has been developed to provide complete instructions for the safe and efficient operation of the MQ Power **Model DCA-125USJ (50 HZ) ULTRA-SILENT™**

GENERATOR.

Before using this GENERATOR, ensure that the operating individual has read and understands all instructions in this manual.

SAFETY MESSAGE ALERT SYMBOLS

The three (3) Safety Messages shown below will inform you about potential hazards that could injure you or others. The Safety Messages specifically address the level of exposure to the operator, and are preceded by one of three words: **DANGER**, **WARNING**, or **CAUTION**.



DANGER: You **WILL** be **KILLED** or **SERIOUSLY** injured if you **DO NOT** follow directions.



WARNING: You **CAN** be **KILLED** or **SERIOUSLY** injured if you **DO NOT** follow directions.



CAUTION: You **CAN** be injured if you **DO NOT** follow directions.

Potential hazards associated with trowel operation will be referenced with "**Hazard Symbols**" which appear throughout this manual, and will be referenced in conjunction with Safety "**Message Alert Symbols**".

HAZARD SYMBOLS



Lethal Exhaust Gases



Engine exhaust gases contain poisonous carbon monoxide. This gas is colorless and odorless, and can cause death if inhaled. **NEVER** operate this equipment in a confined area or enclosed structure that does not provide ample free flow air.



Explosive Fuel



Diesel fuel is extremely flammable, and its vapors can cause an explosion if ignited. **DO NOT** start the engine near spilled fuel or combustible fluids. **DO NOT** fill the fuel tank while the engine is running or hot. **DO NOT** overfill tank, since spilled fuel could ignite if it comes into contact with hot engine parts or sparks from the ignition system. Store fuel in approved containers, in well-ventilated areas and away from sparks and flames. **NEVER** use fuel as a cleaning agent.



Burn Hazards



Engine components can generate extreme heat. To prevent burns, **DO NOT** touch these areas while the engine is running or immediately after operations. **NEVER** operate the engine with heat shields or heat guards removed.



Rotating Parts



NEVER operate equipment with covers, or guards removed. Keep **fingers, hands, hair** and **clothing** away from all moving parts to prevent injury.

DCA-125USJ (50 HZ) — SAFETY MESSAGE ALERT SYMBOLS



Accidental Starting



OFF

ALWAYS place the engine ON/OFF switch in the **OFF** position, when the trowel is not in use.



Respiratory Hazard



ALWAYS wear approved respiratory protection.



Over Speed Conditions



NEVER tamper with the factory settings of the engine governor or settings. Personal injury and damage to the engine or equipment can result if operating in speed ranges above maximum allowable.



Sight and Hearing hazard

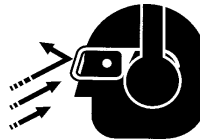

ALWAYS wear approved eye and hearing protection.



Equipment Damage Messages

Other important messages are provided throughout this manual to help prevent damage to your trowel, other property, or the surrounding environment.

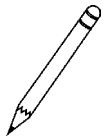
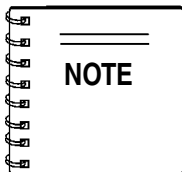

This **generator**, other property, or the surrounding environment could be damaged if you do not follow instructions.

DCA-125USJ (50 HZ) — RULES FOR SAFE OPERATION

CAUTION:



Failure to follow instructions in this manual may lead to serious injury or even death! This equipment is to be operated by trained and qualified personnel only! This equipment is for industrial use only.

The following safety guidelines should always be used when operating the **DCA-125USJ (50 HZ) Generator**:

GENERAL SAFETY

- **DO NOT** operate or service this equipment before reading this entire manual.



- This equipment should not be operated by persons under 18 years of age.

- **NEVER** operate this equipment without proper protective clothing, shatterproof glasses, steel-toed boots and other protective devices required by the job.



- **NEVER** operate this equipment when not feeling well due to fatigue, illness or taking medicine.



- **NEVER** operate this equipment under the influence of drugs or alcohol.



- **NEVER** use accessories or attachments, which are not recommended by MQ Power for this equipment. Damage to the equipment and/or injury to user may result.

- Manufacture does not assume responsibility for any accident due to equipment modifications.

- Whenever necessary, replace nameplate, operation and safety decals when they become difficult read.

- **ALWAYS** check the machine for loosened threads or bolts before starting.

- **NEVER** operate the generator in an explosive atmosphere or near combustible materials. An explosion or fire could result causing severe **bodily harm or even death**.

- **NEVER** touch the hot exhaust manifold, muffler or cylinder. Allow these parts to cool before servicing engine or generator.



- **High Temperatures** – Allow the engine to cool before performing service and maintenance functions. Contact with **hot!** components can cause serious burns.

- The engine of this generator requires an adequate free flow of cooling air. **NEVER** operate the generator in any enclosed or narrow area where free flow of the air is restricted. If the air flow is restricted it will

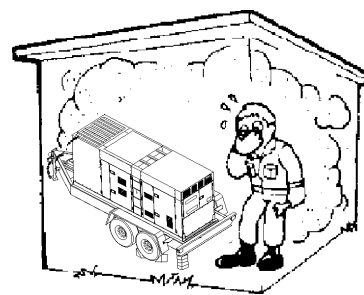

cause serious damage to the generator or engine and may cause injury to people. The generator engine gives off **DEADLY** carbon monoxide gas.

- **ALWAYS** make sure generator is properly grounded.

- **NEVER** use gas piping as an electrical ground.

- **DO NOT** place hands or fingers inside generator engine compartment when engine is running.

- **ALWAYS** make sure generator installation is accordance with **national and local electrical codes**.

- **ALWAYS** have a qualified electrician perform the generator wiring installation.

- **NEVER** power cables or cords **lay in water**.

- **NEVER stand in water** while AC power from the generator is being transfer to a load.

- **NEVER** use a defective or frayed power cable. Check the cable for cuts in the insulation.

- **NEVER** use a extension cord that is frayed or damaged where the insulation has been cut.

- **ALWAYS** make certain that proper extension cord has been selected for the job See Table 5.

- The electrical voltage required to operate the generator can cause severe injury or even death through physical contact with live circuits. Turn all circuit breakers **OFF** before performing maintenance on the generator.

DCA-125USJ (50 HZ) — RULES FOR SAFE OPERATION

■ **ALWAYS** make sure that electrical circuits are properly *grounded* per the *National Electrical Code* (NEC) and local codes before operating generator. Severe *injury* or *death!* by electrocution can result from operating an ungrounded generator.

■ **ALWAYS** be sure the operator is familiar with proper safety precautions and operations techniques before using generator.

■ **ALWAYS** store equipment properly when it is not being used. Equipment should be stored in a clean, dry location out of the reach of children.

■ **ALWAYS** read, understand, and follow procedures in Operator's Manual before attempting to operate equipment.



DANGER:

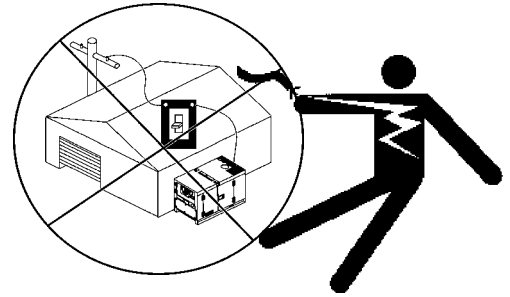

■ Backfeed to a utility system can cause *electrocution* and or property damage. **DO NOT** connect to any building's electrical system except through an approved device or after building main switch is opened. **ALWAYS** have a licensed electrician perform the installation

DANGER:



Never use damaged or worn cables when connecting equipment to the generator. Make sure power connecting cables are securely connected to the generator's output terminals, insufficient tightening of the terminal connections may cause damage to the generator and electrical shock.



DANGER:



NEVER grab or touch a live power cord with wet hands, the possibility exists of electrical shock, electrocution, and even *death!*

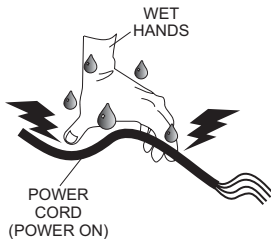

DANGER:

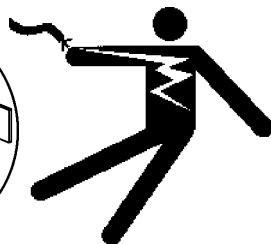
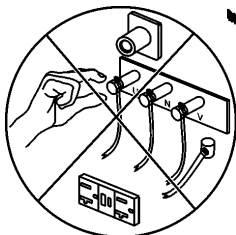

■ **NEVER** touch output terminals during operation. This is extremely dangerous. **ALWAYS** stop the machine and place the circuit breaker in the "OFF" position when contact with the output terminals is required. There exists the possibility of *electrocution, electrical shock or burn, which can cause severe bodily harm or even death!*

CAUTION:



DO NOT touch or open any of the below mentioned components while the generator is running. Always allow sufficient time for the engine and generator to cool before performing maintenance.

Radiator

1. **Radiator Cap** - Removing the radiator cap while the engine is hot will result in high pressurized, boiling water to gush out of the radiator, causing severe scalding to any persons in the general area of the generator.
2. **Coolant Drain Plug** - Removing the coolant drain plug while the engine is hot will result in hot coolant to gush out of the coolant drain plug, therefore causing severe scalding to any persons in the general area of the generator.
3. **Engine Oil Drain Plug** - Removing the engine oil drain plug while the engine is hot will result in hot oil to gush out of the oil drain plug, therefore causing severe scalding to any persons in the general area of the generator.

Maintenance Safety

■ **NEVER** lubricate components or attempt service on a running machine.

■ **ALWAYS** allow the machine a proper amount of time to cool before servicing.



■ Keep the machinery in proper running condition.

■ Fix damage to the machine immediately and always replace broken parts.

DCA-125USJ (50 HZ)— RULES FOR SAFE OPERATION

- **NEVER** run engine without air filter. Severe engine damage may occur.
- **ALWAYS** service air cleaner frequently to prevent engine malfunction.
- **ALWAYS** disconnect the **negative battery terminal** before performing service on the generator.
- **ALWAYS** be sure the operator is familiar with proper safety precautions when operating the generator set.
- **ALWAYS** store equipment properly when not in use.
- **DO NOT** leave the generator running in the **manual mode** unattended.
- **DO NOT** allow unauthorized people to operate this equipment.
- **ALWAYS** read, understand, and follow procedures in Operator's Manual before attempting to operate equipment.
- Refer to the **John Deere Engine Owner's Manual** for engine technical questions or information.

DANGER:



Pay close attention to ventilation when operating the generator inside tunnels and caves. The engine exhaust contains noxious elements. Engine exhaust must be routed to a ventilated area.



Generator Grounding

To guard against electrical shock and possible damage to the equipment, it is important to provide a good **EARTH** ground.

Article 250 (Grounding) of the **National Electrical Code** (NEC) provides guide lines for proper grounding and specifies that the cable ground shall be connected to the grounding system of the building as close to the point of cable entry as practical.

ALWAYS be sure to use the ground terminal (green wire) when connecting a load to the UVWO output terminals.

Battery

The battery contains acids that can cause injury to the eyes and skin. To avoid eye irritation, **always** wear safety glasses. Use well insulated gloves when picking up the battery. Use the following guidelines when handling the battery:

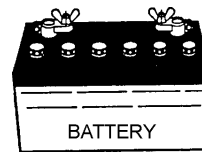

1. **DO NOT** drop the battery. There is the possibility of risk that the battery may explode.
2. **DO NOT** expose the battery to open flames, sparks, cigarettes etc. The battery contains combustible gases and liquids. If these gases and liquids come in contact with a flame or spark, an explosion could occur.
3. **ALWAYS** keep the battery charged. If the battery is not charged a buildup of combustible gas will occur.
4. **ALWAYS** keep battery charging and cables in good working condition. Repair or replace all worn cables.
5. **ALWAYS** recharge the battery in an vented air environment, to avoid risk of a dangerous concentration of combustible gases.
6. In case the battery liquid (dilute sulfuric acid) comes in contact with **clothing or skin**, rinse skin or clothing immediately with plenty of water.
7. In case the battery liquid (dilute sulfuric acid) comes in contact with your **eyes**, rinse eyes immediately with plenty of water, then contact the nearest doctor or hospital, and seek medical attention.

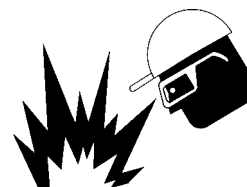

Transporting

- **ALWAYS** shutdown engine before transporting.
- Tighten both fuel tank caps securely.
- If generator is mounted on a trailer, make sure trailer complies with all local and state safety transportation laws. See next page "**Towing Safety Precautions**" for basic towing techniques.

DCA-125USJ (50 HZ)— RULES FOR SAFE OPERATION

Towing Safety Precautions

CAUTION:



Conform to **Department of Transportation (DOT) Safety Towing Regulations** before towing generator.

To reduce the possibility of an accident while transporting the generator on public roads, always make sure the trailer that supports the generator and the towing vehicle are in good operating condition and both units are mechanically sound.

The following list of suggestions should be used when towing your generator:

- Make sure the hitch and coupling of the towing vehicle are rated equal to, or greater than the trailer "gross vehicle weight rating."
- **ALWAYS** inspect the hitch and coupling for wear. **NEVER** tow a trailer with defective hitches, couplings, chains etc.
- Check the tire air pressure on both towing vehicle and trailer. **Trailer tires should be inflated to 50 psi cold.** Also check the tire tread wear on both vehicles.
- **ALWAYS** make sure the trailer is equipped with a "Safety Chain".
- **ALWAYS** attach trailer's safety chains to towing vehicle properly.
- **ALWAYS** make sure the vehicle and trailer directional, backup, brake, and trailer lights are connected and working properly.
- The maximum speed for highway towing is **55 MPH** unless posted otherwise. Recommended off-road towing is not to exceed **15 MPH** or less depending on type of terrain.
- Place **chock blocks** underneath wheel to prevent **rolling**, while parked.
- Use the trailer's swivel jack to adjust the trailer height to a level position while parked.
- Avoid sudden stops and starts. This can cause skidding, or jack-knifing. Smooth, gradual starts and stops will improve towing.

- Avoid sharp turns.
- Trailer should be adjusted to a level position at all times when towing.
- Raise and lock trailer wheel stand in up position when transporting.
- DOT Requirements include the following:
 - Connect and test electric brake operation.
 - Secure portable power cables in cable tray with tie wraps.

Emergencies

- **ALWAYS** know the location of the nearest **fire extinguisher**.

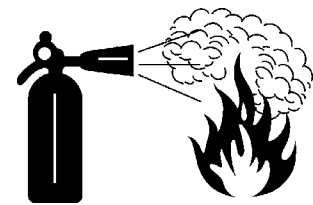

- **ALWAYS** know the location of the nearest **first aid kit**.



- In emergencies **always** know the location of the nearest phone or **keep a phone on the job site**. Also know the phone numbers of the nearest **ambulance, doctor** and **fire department**. This information will be invaluable in the case of an emergency.

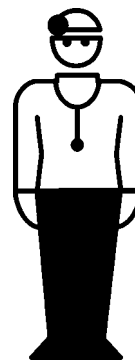
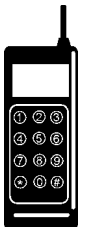

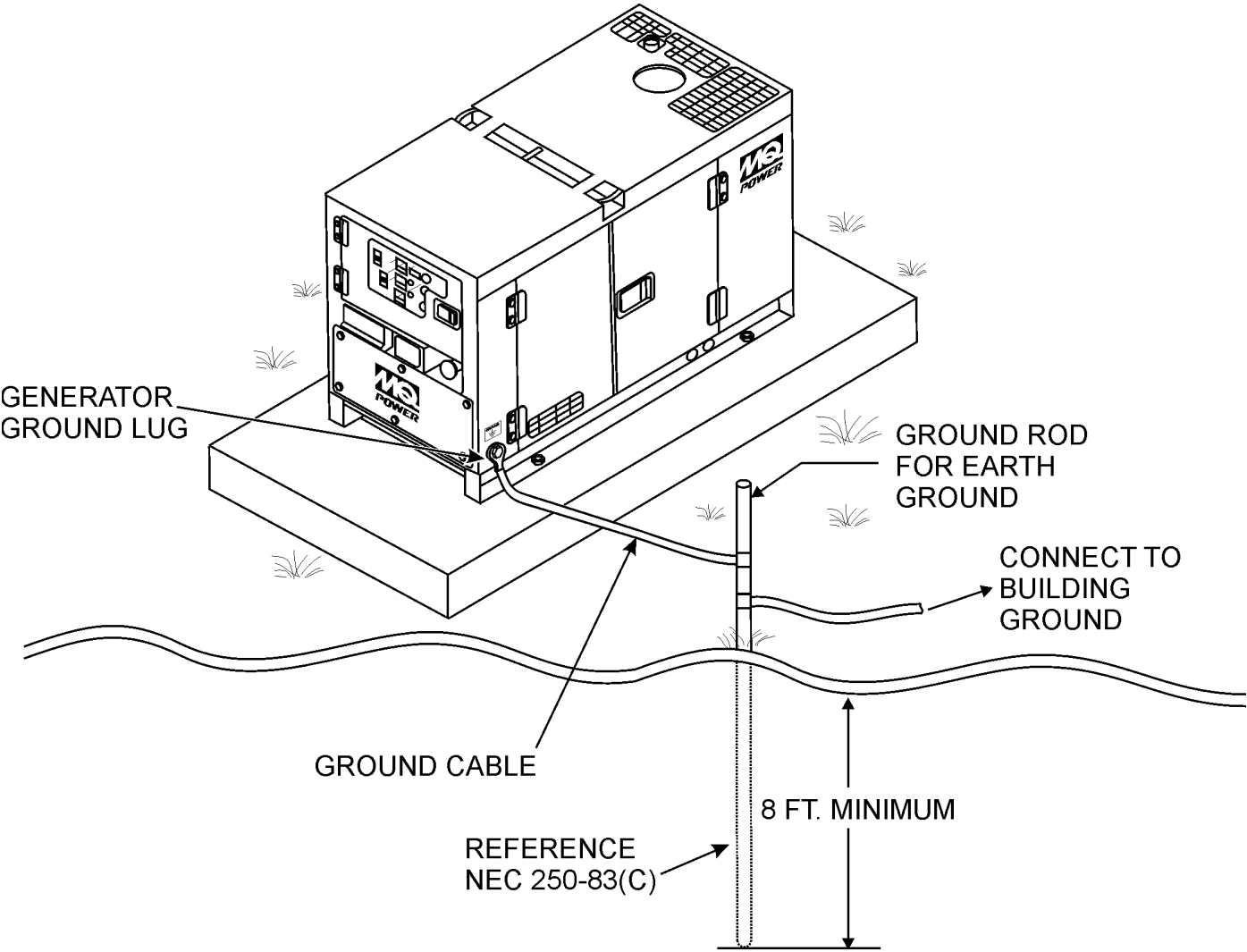

Figure 2. Typical Generator Grounding Application

Outdoor Installation

Install the generator in a area that is free of debris, bystanders, and overhead obstructions. Make sure the generator is on secure level ground so that it cannot slide or shift around. Also install the generator in a manner so that the exhaust will not be discharged in the direction of nearby homes.

The installation site must be relatively free from moisture and dust. All electrical equipment should be protected from excessive moisture. Failure to do will result in deterioration of the insulation and will result in short circuits and grounding.

Foreign materials such as dust, sand, lint and abrasive materials have a tendency to cause excessive wear to engine and alternator parts.

CAUTION:



Pay close attention to ventilation when operating the generator inside tunnels and caves. The engine exhaust contains noxious elements. Engine exhaust must be routed to a ventilated area.

Indoor Installation

Exhaust gases from diesel engines are extremely poisonous. Whenever an engine is installed indoors the exhaust fumes must be vented to the outside. The engine should be installed at least two feet from any outside wall. Using an exhaust pipe which is too long or too small can cause excessive back pressure which will cause the engine to heat excessively and possibly burn the valves.

Mounting

The generator must be mounted on a solid foundation (such as concrete) and set firmly on the foundation to isolate vibration of the generator when it is running. The generator must set at least 6 inches above the floor or grade level (in accordance to NFPA 110, Chapter 5-4.1). **DO NOT** remove the metal skids on the bottom of the generator. They are to resist damage to the bottom of the generator and to maintain alignment.

Generator Grounding

To guard against electrical shock and possible damage to the equipment, it is important to provide a good **EARTH** ground.

Article 250 (Grounding) of the National Electrical Code (NEC) provides guide lines for proper grounding and specifies that the cable ground shall be connected to the grounding system of the building as close to the point of cable entry as practical.

NEC articles 250-64(b) and 250-66 set the following grounding requirements:

1. Use one of the following wire types to connect the generator to earth ground.
 - a. Copper - 10 AWG (5.3 mm²) or larger.
 - b. Aluminum - 8 AWG (8.4 mm²) or larger.
2. When grounding the generator (Figure 2) connect the ground cable between the lock washer and the nut on the generator and tighten the nut fully. Connect the other end of the ground cable to earth ground.
3. NEC article 250-52(c) specifies that the earth ground rod should be buried a minimum of 8 ft. into the ground.

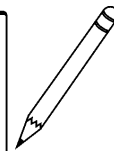
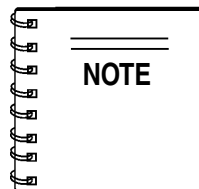

When connecting the generator to any buildings electrical system **ALWAYS** consult with a licensed electrician.

DCA-125USJ (50 HZ)—TOWING SAFETY PRECAUTIONS

Towing Safety Precautions

CAUTION:



Check with your local county or state safety towing regulations before towing your generator.

To reduce the possibility of an accident while transporting the generator on public roads, always make sure the trailer (Figure 4) that supports the generator and the towing vehicle are in good operating condition and both units are mechanically sound.

The following list of suggestions should be used when towing your generator:

- Make sure the hitch and coupling of the towing vehicle are rated equal to, or greater than the trailer "gross vehicle weight rating" (GVWR).
- **ALWAYS** inspect the hitch and coupling for wear. **NEVER** tow a trailer with defective hitches, couplings, chains etc.
- Check the tire air pressure on both towing vehicle and trailer. Also check the tire tread wear on both vehicles.
- **ALWAYS** make sure the trailer is equipped with a "Safety Chain".

- **ALWAYS** attach trailer's safety chain to bumper of towing vehicle.
- **ALWAYS** make sure the vehicle and trailer directional, backup, brake, and trailer lights are connected and working properly.
- The maximum speed for highway towing is **55 MPH** unless posted otherwise. Recommended off-road towing is not to exceed **15 MPH** or less depending on type of terrain.
- Place *chocked blocks* underneath wheel to prevent **rolling**, while parked.
- Place *support blocks* underneath the trailer's bumper to prevent **tipping**, while parked.
- Use the trailer's hand winch to adjust the height of the trailer, then insert locking pin to lock wheel stand in place, while parked.
- Avoid sudden stops and starts. This can cause skidding, or jackknifing. Smooth, gradual starts and stops will improve gas mileage.
- Avoid sharp turns to prevent rolling.
- Remove wheel stand when transporting.
- **DO NOT** transport generator with fuel in tank.

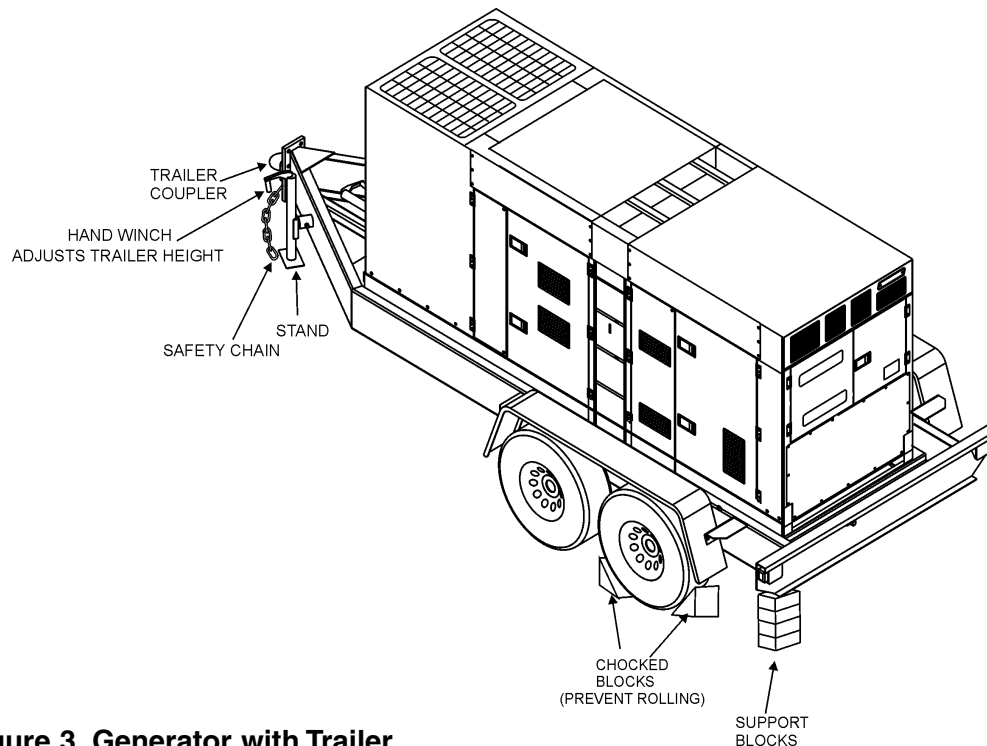

Figure 3. Generator with Trailer

CAUTION:



ALWAYS make sure the trailer is in good operating condition. Check the tires for proper inflation and wear. Also check the wheel lug nuts for proper tightness.

Explanation of Chart:

This section is to provide the user with trailer service and maintenance information. The service and maintenance guidelines referenced in this section apply a wide range of trailers. Remember periodic inspection of the trailer will ensure safe towing of the equipment and will prevent damage to the equipment and personal injury.

It is the purpose of this section to cover the major maintenance components of the trailer. The following trailer components will be discussed in this section:

- Brakes
- Tires
- Lug Nut Torquing
- Suspension
- Electrical
- Brake Troubleshooting Tables

Use the following definitions when reading Table 2.

1. **Fuel Cell** - Provides an adequate amount of fuel for the equipment in use. Fuel cells must be empty when transporting equipment.
2. **Braking System** - System employed in stopping the trailer. Typical braking systems are electric, surge, hydraulic, hydraulic-surge and air.
3. **GVWR**- Gross Vehicle Weight Rating (GVWR), is the maximum number of pounds the trailer can carry, including the fuel cell (empty).
4. **Frame Length** - Measurement is from the ball hitch to the rear bumper (reflector).
5. **Frame Width** - Measurement is from fender to fender
6. **Jack Stand** - Trailer support device with maximum pound requirement from the tongue of the trailer.
7. **Coupler** - Type of hitch used on the trailer for towing.
8. **Tire Size** - Indicates the diameter of the tire in inches (10,12,14, etc.), and the width in millimeters (175,185,205, etc.). The tire diameter must match the diameter of the tire rim.
9. **Tire Ply** - The tire ply (layers) number is rated in letters; 2-ply,4-ply,6-ply, etc.
10. **Wheel Hub** - The wheel hub is connected to the trailer's axle.
11. **Tire Rim** - Tires mounted on a tire rim. The tire rim must match the size of the tire.
12. **Lug Nuts** - Used to secure the wheel to the wheel hub. Always use a torque wrench to tighten down the lug nuts. See Table 17 and Figure 67 for lug nut tightening and sequence.
13. **Axle** - Indicates the maximum weight the axle can support in pounds, and the diameter of the axle expressed in inches. Please note that some trailers have a double axle. This will be shown as 2-6000 lbs., meaning two axles with a total weight capacity of 6000 pounds.
14. **Suspension** - Protects the trailer chassis from shocks transmitted through the wheels. Types of suspension used are leaf, Q-flex, and air ride.
15. **Electrical** - Electrical connectors (looms) are provided with the trailer so the brake lights and turn signals can be connected to the towing vehicle.
16. **Application** - Indicates which units can be employed on a particular trailer.

DCA-125USJ (50 HZ)— GENERATOR DECALS

The DCA-125USJ (50 HZ) generator is equipped with a number of safety decals (Figure 4). These decals are provided for operator safety and maintenance information. The illustration below and on the preceding page show the decals as they appear on the machine. Should any of these decals become unreadable, replacements can be obtained from your dealer.

OPERATING PROCEDURES

Manual Starting

1. Check the engine oil, coolant, and fuel levels. Replenish if necessary.
2. Place all Generator Circuit Breakers in the "OFF" position and close all doors.
3. Check that the Voltage select switch (or the Voltage change-over board) is present at desired voltage.
(In case of generator having multiple voltage ratings.)
4. Set the Engine speed switch to the "LOW" position.
5. Turn the Auto-Off/Reset-Manual switch to the "Manual" position to start the engine. If the engine fails to start in the specified number of attempts, the overcrank lamp will indicate and the Auto-Off/Reset-Manual switch must be returned to the "Off/Reset" position before proceeding.
6. When the engine is ready for starting during cold weather operating conditions, push the water heater button for approximately 30 seconds. Start engine using the Auto-Off/Reset-Manual switch to the "Manual" position. As soon as the engine starts, release the button.
If the engine still does not start, utilize the water heater until water is warm. If additional water heater is supplied.)
7. After starting, allow the engine to run for 1 or 2 minutes to warm-up. At temperatures below freezing, this time period must be extended to 2 to 4 minutes.
8. When the engine starts, immediately check for abnormal noise, vibration, fluid leakage or any indication of a problem. Check the control panel gauges. If all is normal, let the engine remain at the "Low" position for a short time, depending on the ambient conditions, warm up.
9. After sufficient warm-up time has elapsed, set the Engine speed switch to the "High" position and the unit is ready for operation.
10. Check the NO-Load speed as shown in the table below.
60Hz operation—Approx. 63.0Hz (1800rpm)
11. Adjust the Voltage Regulator to the specified voltage.

Manual Stopping

1. Place the Generator Circuit Breakers in the "OFF" position.
2. Set the Engine speed switch to the "LOW" position, and allow the unit to cool for a few minutes.
3. Turn the Auto-Off/Reset-Manual switch to the "Off/Reset" position.

Auto Starting/Stopping

1. With the Auto/Manual switch in the Auto position, the Auto Starting/Stopping controller monitors remote start contacts. Closure of the remote start contacts will begin engine cranking. When the contacts are opened cranking will stop. If cranking the engine will stop. All functions for the Automatic shutdown System work as in Manual Starting/stopping.
2. For cold weather conditions utilize the water heater until water is warm. If the engine still does not start, please operate as in Manual Starting.

Emergency Stopping

1. Place the Generator Circuit Breakers in the "OFF" position.
2. Turn the Auto-Off/Reset-Manual switch to the "Off/Reset" position.

M35200010

P/N M3552000103

SAFETY INSTRUCTIONS

Improper operation of this machine can cause severe injury or death.

- Read the instruction manual carefully before operating or servicing. This machine should only be operated by a person with sufficient knowledge and skill to ensure safe operation. High voltage circuits are located inside the output terminal cover and control panel.
- Close the cover and control panel before operating. Moving parts and hot surfaces are contained within the enclosure.
- Close all doors and lock them before operating.

M92010030

P/N M9520100304

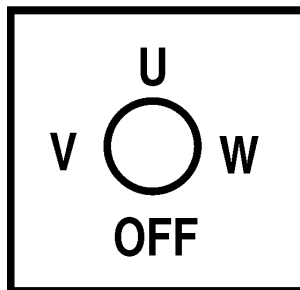

P/N M9520000104

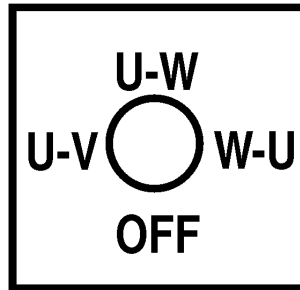

P/N M9520000204

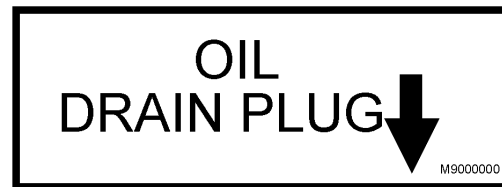

P/N M950000004



P/N M9510200002

OVER CURRENT RELAY

If it is Impossible to reset the CIRCUIT BREAKER, open the control panel and push the RESET BUTTON as below.

M92020010

P/N M9520200104

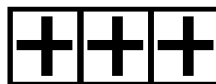

P/N M9500300104



P/N M9500300004



P/N M9500500004



P/N M9503000103

Figure 4. Generator Decals

DCA-125USJ (50 HZ)— GENERATOR DECALS

	⚠ WARNING	⚠ WARNING	⚠ WARNING
	ELECTRIC SHOCK HAZARD <ul style="list-style-type: none"> Do not touch output terminals when this machine is operating. Turn power off before servicing 	ELECTRIC SHOCK HAZARD <ul style="list-style-type: none"> Always complete the grounding path from the ground terminal on this genset to an external grounding source. See instruction manual for details. 	<ul style="list-style-type: none"> Before connecting this generator to any building's electrical system, a licensed electrician must install an isolation (transfer) switch. Serious injury or death may result without this transfer switch

M9520 100503

P/N M9520100503

	⚠ WARNING
	HOT COOLANT can cause severe burns. <ul style="list-style-type: none"> Do not remove cap if radiator is hot.

M90310000

P/N M9503100004

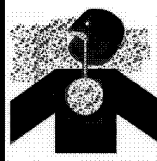
	⚠ WARNING
	ENGINE EXHAUST can cause severe injury or death. <ul style="list-style-type: none"> Use only in open, well ventilated areas or vent exhaust outside.

M90320000

P/N M9503200004

DANGER
HIGH VOLTAGE

M9520100401

P/N M9520100404

⚠ CAUTION
Stop engine before switching

M9520100204

P/N M9520100204

	⚠ CAUTION
	MOVING PARTS can cause severe injury. <ul style="list-style-type: none"> Do not operate with doors open. Stop engine before servicing.

M90300000

P/N M9503000004

NOTE
To use 50 amp receptacles, adjust the voltage selector switch to the single phase position and the main line circuit breaker to the on position.

P/N M1500020

P/N M1550000204

	⚠ CAUTION
	HOT PARTS can burn skin. <ul style="list-style-type: none"> Do not touch until the machine has sufficiently cooled.

M91010000

P/N M9510100004

	⚠ WARNING
	ELECTRIC SHOCK HAZARD <ul style="list-style-type: none"> Do not touch output terminals while this machine is operating. Turn power off before servicing.

P/N M9520100503

	⚠ WARNING
	ELECTRIC SHOCK HAZARD <ul style="list-style-type: none"> Do not touch internal wiring or connections while this machine is operating. Turn power off before servicing.

M92010000

P/N M9520100004

⚠ CAUTION
This machine stops and starts Automatically and without notice.

P/N B15200010

P/N B15200010

Figure 4. Generator Decals (Cont.)

DCA-125USJ (50 HZ) Series Familiarization

Generator

The MQ Power Model DCA-125USJ (50 HZ) is a 80 kW **generator** (Figure 5) that is designed as a high quality portable (requires a trailer for transport) power source for telecom sites, lighting facilities, power tools, submersible pumps and other industrial and construction machinery.

Engine Operating Panel

The "Engine Operating Panel" is provided with the following:

- Tachometer
- Water Temperature Gauge
- Oil Pressure Gauge
- Charging Ammeter Gauge
- Fuel Level Gauge
- Pre-heat Lamp
- Panel Light/Panel Light Switch
- Auto ON/OFF Engine Controller (MPEC)
- Fuel Leak Detected Alarm Lamp

Generator Control Panel

The "Generator Control Panel" is provided with the following:

- Frequency Meter (Hz)
- AC Ammeter (Amps)
- AC Voltmeter (Volts)
- Ammeter Change-Over Switch
- Voltmeter Change-Over Switch
- Voltage Regulator
- 3-Pole, 300 amp Main Circuit Breaker

Control Box

The "Control Box", located behind the **Generator Control Panel**, is provided with the following:

- Automatic Voltage Regulator
- Current Transformer
- Over-Current Relay
- Voltage Rectifier
- Starter Relay
- Engine Controller (Computer Controlled)
- Voltage Selector Switch

Output Terminal Panel

The "Output Terminal Panel" is provided with the following:

- Three 100/200V output receptacles (CS-6369), 50A
- Three auxiliary circuit breakers, 50A
- Two 100V output receptacles (GFCI), 20A
- Two GFCI circuit breakers, 20A
- Five output terminal lugs (3Ø power)
- Battery Charger (Optional)
- Water Heater (Optional)

Open Delta Excitation System

The DCA-125USJ (50 HZ) generator is equipped with the state of the art "**Open-Delta**" excitation system. The open delta system consist of an electrically independent winding wound among stationary windings of the AC output section.

There are four connections of the open delta A, B, C and D. During steady state loads, the power from the voltage regulator is supplied from the parallel connections of A to B, A to D, and C to D. These three phases of the voltage input to the voltage regulator are then rectified and are the excitation current for the exciter section.

When a heavy load, such as a motor starting or a short circuit occurs, the automatic voltage regulator (AVR) switches the configuration of the open delta to the series connection of B to C. This has the effect of adding the voltages of each phase to provide higher excitation to the exciter section and thus better voltage response during the application of heavy loads.

The connections of the AVR to the AC output windings are for sensing only. No power is required from these windings.

The open-delta design provides virtually unlimited excitation current, offering maximum motor starting capabilities. The excitation does not have a "**fixed ceiling**" and responds according the demands of the required load.

Engine

The **DCA-125USJ (50 HZ)** is powered by a 4 cycle, water cooled, direct injection, turbocharged **JOHN DEERE Model 6068TF275 Diesel Engine**. This engine is designed to meet every performance requirement for the generator. Reference Table 1 for engine specifications.

In keeping with MQ Power's policy of constantly improving its products, the specifications quoted herein are subject to change without prior notice.

Electric Governor System

The electric governor system controls the RPMs of the engine. When the engine demand increases or decreases, the governor system regulates the frequency variation to $\pm 25\%$.

Extension Cables

When electric power is to be provided to various tools or loads at some distance from the generator, extension cords are normally used. Cables should be sized to allow for distance in length and amperage so that the voltage drop between the generator and point of use (load) is held to a minimum. Use the cable selection chart (Table 5) as a guide for selecting proper extension cable size.

DCA-125USJ (50 HZ)— MAJOR COMPONENTS

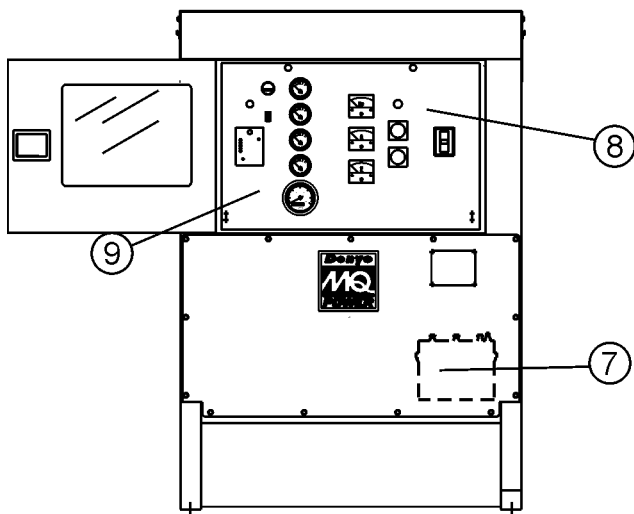
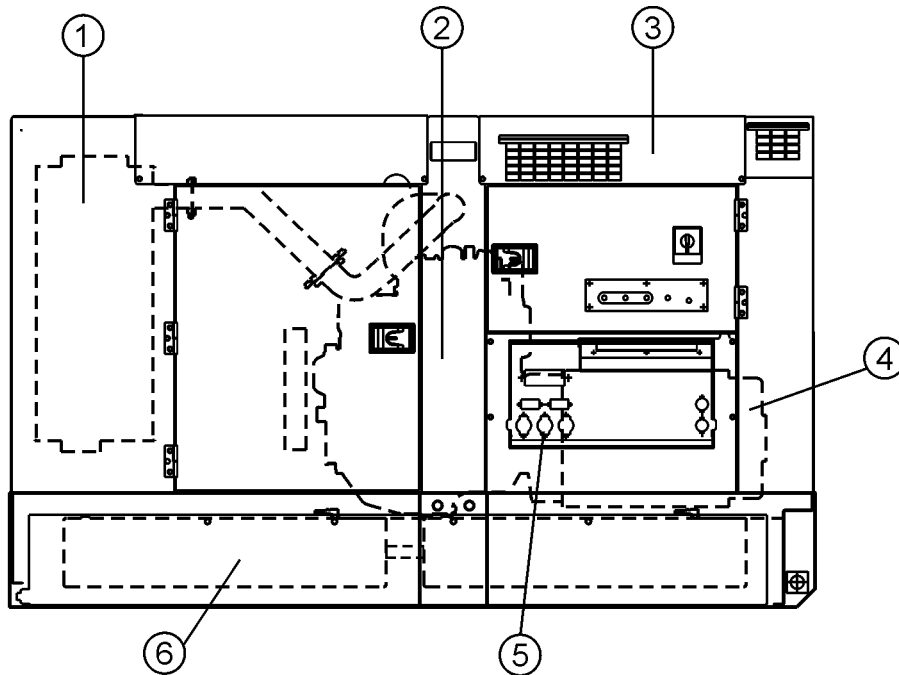

Figure 5. Major Components

Table 3. Generator Major Components

ITEM NO.	DESCRIPTION
1	Muffler Assembly
2	Engine Assembly
3	Enclosure Assembly
4	Generator Assembly
5	Output Terminal Assembly
6	Fuel Tank Assembly
7	Battery Assembly
8	Generator Control Panel Assembly
9	Engine Operating Panel Assembly

DCA-125USJ (50 HZ)— GENERATOR CONTROL PANEL

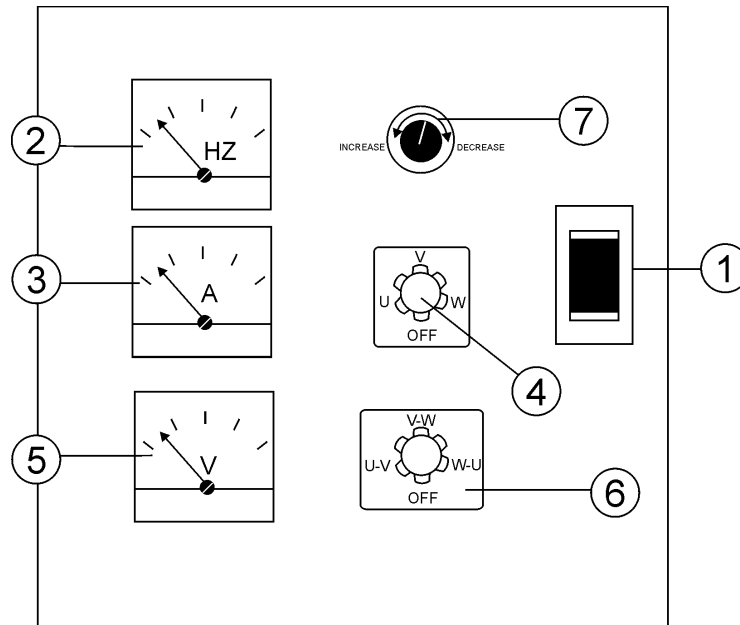

Figure 6. Generator Control Panel

The definitions below describe the controls and functions of the DCA-125USJ (50 HZ) **Generator Control Panel** (Figure 6).

1. **Main Circuit Breaker** – This three-pole, 300A main breaker is provided to protect the the **U, V, and W Output Terminal Lugs** from overload.
2. **Frequency Meter** – Indicates the output frequency in hertz (Hz). Normally 50 Hz.
3. **AC Ammeter** – Indicates the amount of current the load is drawing from the generator per leg selected by the ammeter phase-selector switch.
4. **Ammeter Change-Over Switch** – This switch allows the AC ammeter to indicate the current flowing to the load connected to any phase of the output terminals, or to be switched off. This switch does not effect the generator output in any fashion, it is for current reading only.
5. **AC Voltmeter** – Indicates the output voltage present at the **U, V, and W Output Terminal Lugs**.
6. **Voltmeter Change-Over Switch** – This switch allows the AC voltmeter to indicate phase to phase voltage between any two phases of the output terminals or to be switched off.
7. **Voltage Regulator Control** – Allows $\pm 15\%$ manual adjustment of the generator's output voltage.

Located behind the generator control panel is the **Generator Control Box**. This box contains some of the necessary electronic components required to make the generator function.

The **Control Box** is equipped with the following major components:

- Over-Current Relay
- Voltage Rectifier (AVR)
- Starter Relay
- Current Transformer
- Voltage Selector Switch

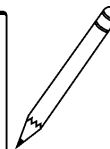
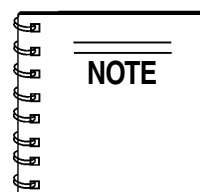

Remember the **overcurrent relay** monitors the current flowing from the **U, V, and W Output Terminal Lugs** to the load.

In the event of a short circuit or over current condition, it will automatically trip the 60 amp main breaker.

To restore power to the **Output Terminal Panel**, press the **reset** button on the overcurrent relay and place the **main** circuit breaker in the **closed** position (**ON**).

DCA-125USJ (50 HZ)— ENGINE OPERATING PANEL

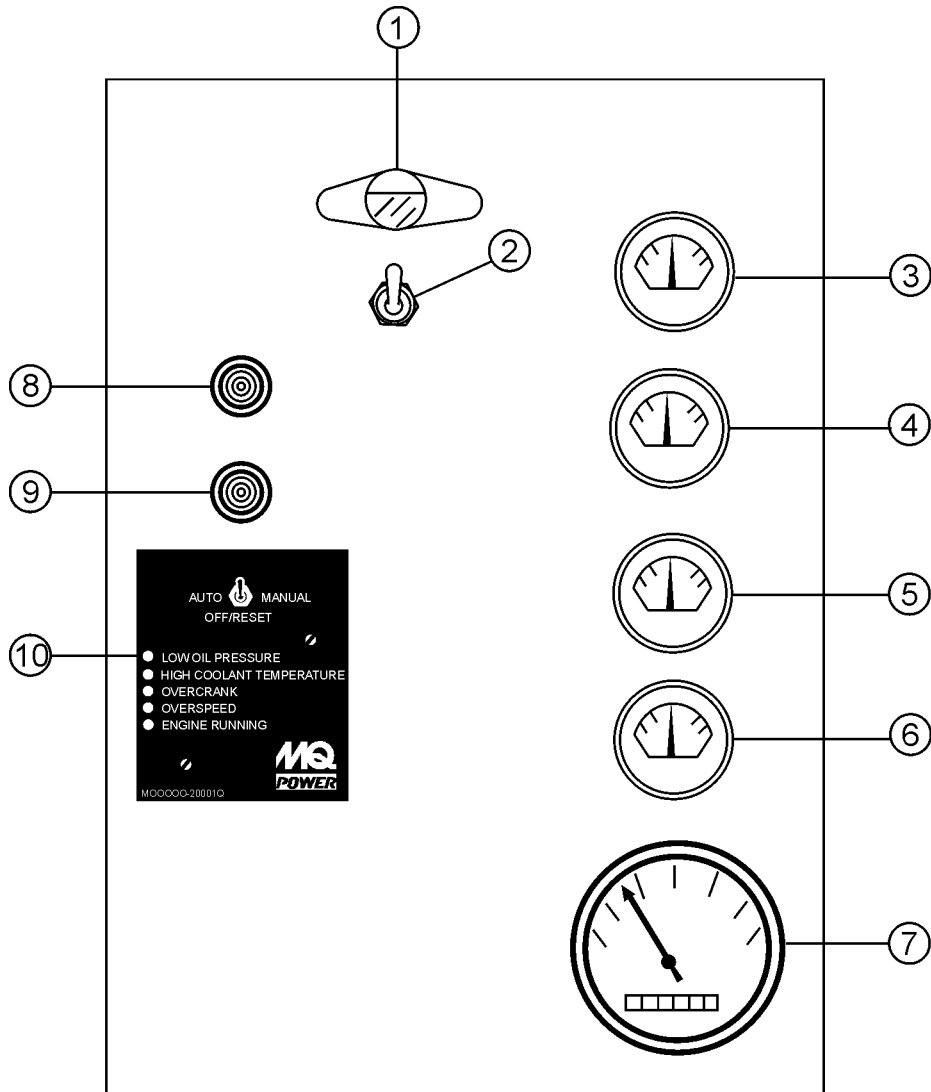
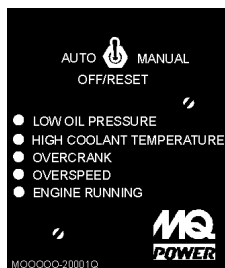

Figure 7. Engine Operating Panel

DCA-125USJ (50 HZ)— ENGINE OPERATING PANEL

The definitions below describe the controls and functions of the DCA-125USJ (50 HZ) **Engine Operating Panel** (Figure 7):

1. **Panel Light** – Normally used in dark areas or at night time. When activated, panel lights will illuminate. When the generator is not in use be sure to turn the panel light switch to the **OFF** position.
2. **Panel Light Switch** – When activated will turn on control panel light.
3. **Oil Pressure Gauge** – During normal operation this gauge be should read between 35 to 65 psi. When starting the generator the oil pressure may read a little higher, but after the engine warms up the oil pressure should return to the correct pressure range.
4. **Water Temperature Gauge** – During normal operation this gauge be should read between 180° and 221°F.
5. **Charging Ammeter Gauge** – Indicates the current being supplied by the engine's alternator which provides current for generator's control circuits and battery charging system.
6. **Fuel Gauge** - Indicates amount of diesel fuel available.
7. **Tachometer** – Indicates engine speed in RPM's for 50 Hz operation. This meter should indicate 1500 RPM's when the rated load is applied. In addition a built in hour meter will record the number of operational hours that the generator has been in use.
8. **Pre-Heat Lamp** – As the engine cranks, this lamp will illuminate to indicate automatic preheating of the engine. When the lamp turns off, the engine has been preheated and will start automatically.
9. **Fuel Leak Detected Alarm Lamp** – This lamp will illuminate when a leak in the fuel tank containment enclosure is detected.
10. **Auto On/Off Engine Controller (MPEC) –**
This controller has a vertical row of status LED's (inset), that when lit, indicate that an engine malfunction (fault) has been detected. When a fault has been detected the engine controller will evaluate the fault and all major faults will shutdown the generator.



During **cranking cycle**, The MPEC will attempt to crank the engine for 10 seconds before disengaging. If the engine does not engage (start) by the third attempt, the engine will be shutdown by the engine controller's **Over Crank Protection** mode. If the engine engages at a speed (RPM's) that is not safe, the controller will shutdown the engine by initializing the **Over Speed Protection** mode.

Also the engine controller will shut down the engine in the event of low oil pressure, high coolant temperature, low coolant level, and loss of magnetic pickup. These conditions can be observed by monitoring the **LED** status indicators on the front of the controller module.

A. MPEC Control Switch – This switch controls the running of the unit. If this switch is set to the **OFF/RESET** position, the unit will not run. When this switch is set to the **MANUAL** position, the generator will start immediately.

If the generator is to be connected to a building's AC power source via a transfer switch (isolation), place the switch in the **AUTO** position. In this position the generator will monitor the AC line output from the building's power source.

B. Low Oil Pressure – Indicates the engine pressure has fallen below 15 psi. The oil pressure is detected using variable resistive values from the oil pressure sending unit. This is considered a **major** fault.

C. High Coolant Temperature – Indicates the engine temperature has exceeded 239°F. The engine temperature is detected using variable resistive values from the temperature sending unit. This is considered a **major** fault.

D. Overcrank Shutdown – Indicates the unit has attempted to start a pre-programmed number of times, and has failed to start. The number of cycles and duration are programmable. It is pre-set at 3 cycles with a 10 second duration. This is considered a **major** fault.

E. Overspeed Shutdown – Indicates the engine is running at an unsafe speed. This is considered a **major** fault.

F. Engine Running – Indicates that engine is running at a safe operating speed.

DCA-125USJ (50 HZ)— OUTPUT TERMINAL PANEL FAMILIARIZATION

Output Terminal Panel

The **Output Terminal Panel** (Figure 8) shown below is located on the right-hand side (left from control panel) of the generator. Lift up on the cover to gain access to receptacles and terminal lugs.

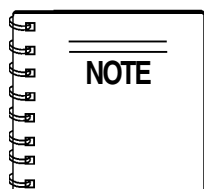

Terminal legs "O" and "Ground" are considered **bonded grounds**.

Output Terminal Familiarization

The "**Output Terminal Panel**" (Figure 8) is provided with the following:

- Three (3) 100/200V output receptacles @ 50 amp
- Three (3) Circuit Breakers @ 50 amps
- Two (2) 100V GFCI receptacles @ 20 amp
- Two (2) GFCI Circuit Breakers @ 20 amps
- Five (5) Output Terminal Lugs (U, V, W, O, Ground)

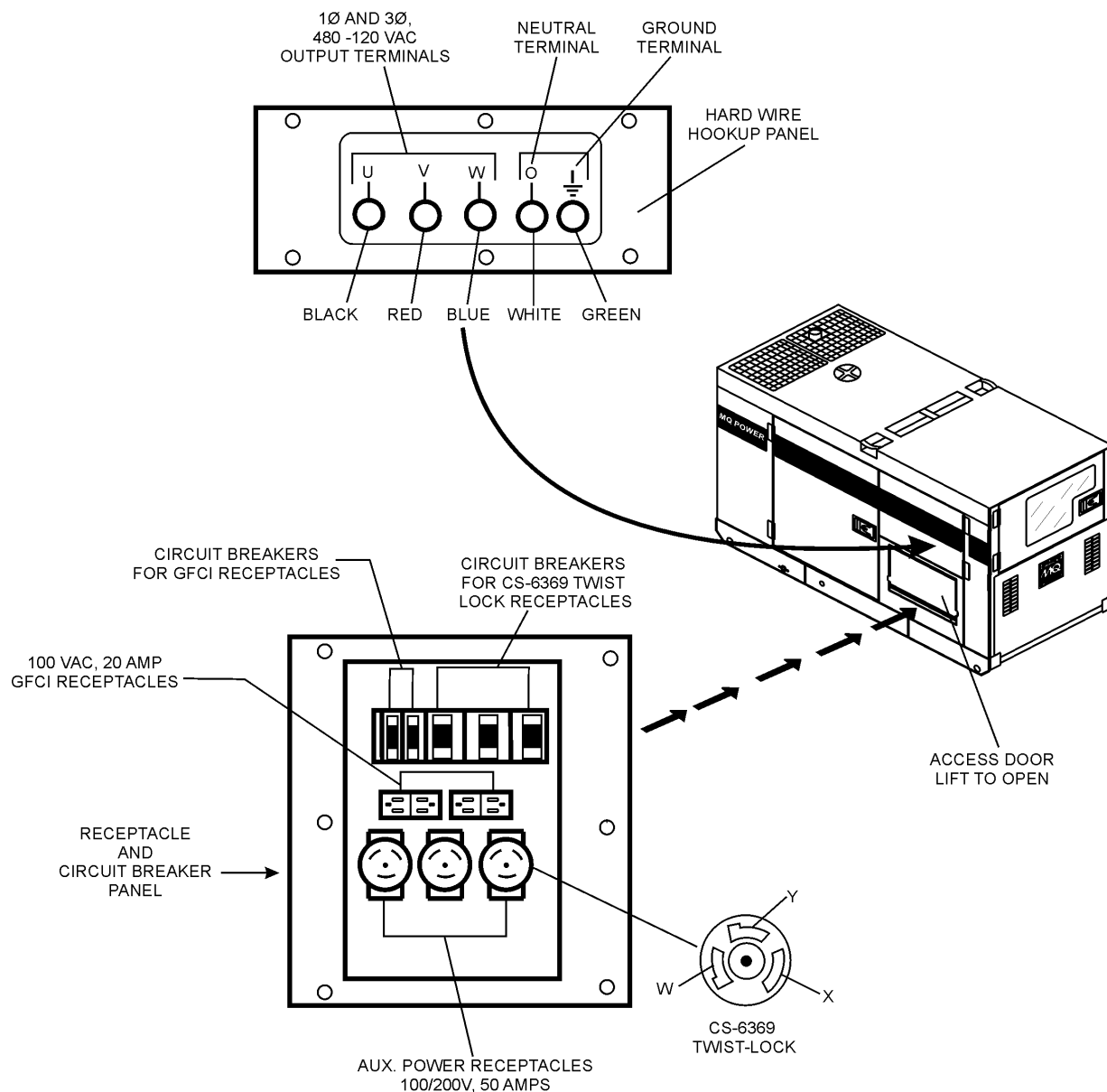

Figure 8. Output Terminal Panel

DCA-125USJ (50 HZ)— OUTPUT TERMINAL PANEL FAMILIARIZATION

100 VAC GFCI Receptacles

There are two 100 VAC, 20 amp GFCI (Duplex Nema 5-20R) receptacles provided on the output terminal panel. These receptacles can be accessed in **any voltage selector switch** position. Each receptacle is protected by a 20 amp circuit breaker. These breakers are located directly above the GFCI receptacles. Remember the load output (current) of both GFCI receptacles is dependent on the load requirements of the UVWO terminals.

Pressing the **reset** button resets the GFCI receptacle after being tripped. Pressing the "**Test Button**" (See Figure 9) in the center of the receptacle will check the GFCI function. Both receptacles should be tested at least once a month.

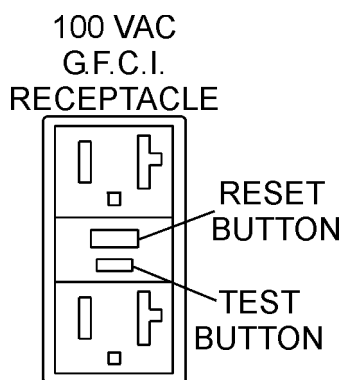

Figure 9. G.F.C.I. Receptacle

Twist Lock Dual Voltage 100/200 VAC Receptacles

There are three 100/200V, 50 amp auxilliary twist-lock (CS-6369) receptacles (Figure 10) provided on the output terminal panel. These receptacles can **only** be accessed when the voltage selector switch is placed in the **single-phase 240/120 position**.

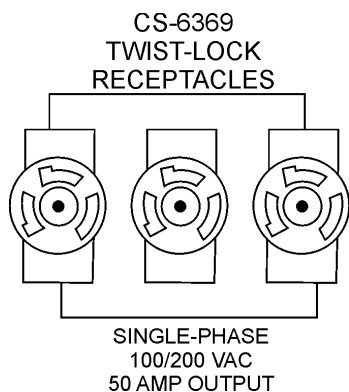

Figure 10. 100/200V Twist-Lock Auxiliary Receptacles

Each auxilliary receptacle is protected by a 50 amp circuit breaker. These breakers are located directly above the GFCI receptacles. Remember the load output (current) on all three receptacles is dependent on the load requirements of the **Output Terminal Lugs**.

Turn the **voltage regulator control knob** (Figure 11) on the control panel to obtain the desired voltage. Turning the knob clockwise will **increase** the voltage, turning the knob counter-clockwise will **decrease** the voltage.

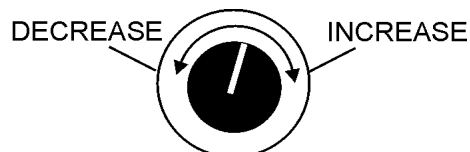

Figure 11. Voltage Regulator Control Knob

Removing the Plastic Face Plate (Hard Wire Hookup Panel)

The **Output Terminal Lugs** are protected by a plastic face plate cover (Figure 12). Un-screw the securing bolts and lift the plastic terminal cover to gain access to the terminal enclosure.

After the load wires have been securely attached to the terminal lugs, reinstall the plastic face plate.

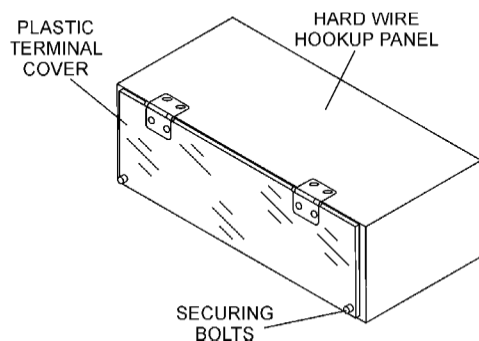

Figure 12. Plastic Face Plate (Output Terminal Lugs)

DCA-125USJ (50 HZ)— OUTPUT TERMINAL PANEL FAMILIARIZATION

Connecting Loads

Loads can be connected to the generator by the **Output Terminal Lugs** or the convenience receptacles. (See Figure 13). Make sure to read the operation manual before attempting to connect a load to the generator.

To protect the output terminals from overload, a 3-pole, 300A **main** circuit breaker is provided. Make sure to switch **ALL** circuit breakers to the **OFF** position prior to starting the engine.

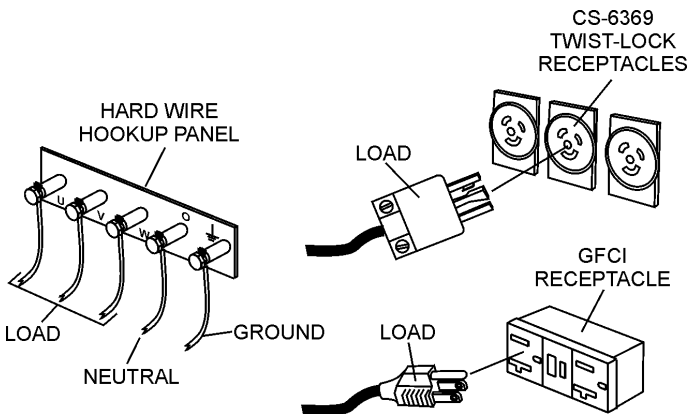

Figure 13. Connecting Loads

Over Current Relay

An **over current relay** (Figure 14) is connected to the main circuit breaker. In the event of an overload, both the circuit breaker and the over current relay may trip. If the circuit breaker can not be reset, the **reset button** on the over current relay must be pressed. The over current relay is located in the control box.

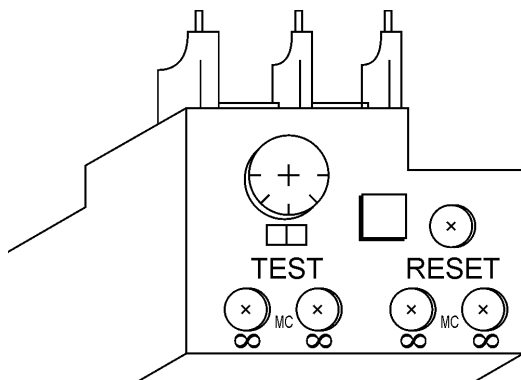

Figure 14. Over Current Relay

Blower Fan

This unit has an intake fan located at the rear of the machine to draw outside air into the cabinet to cool the engine. The fan has a 10 amp AC fuse located beneath the **Voltage Selector Switch** (Figure 15).

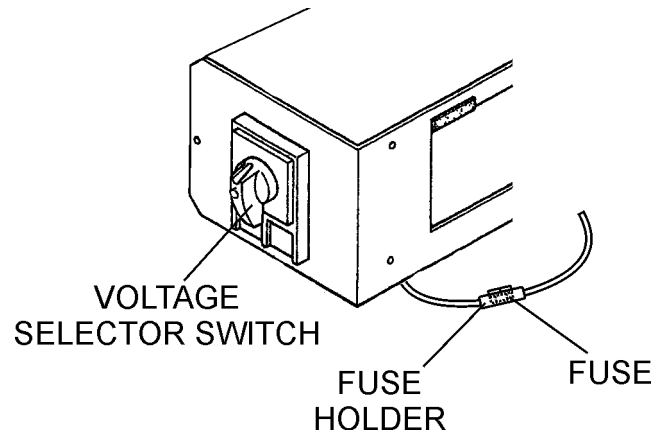

Figure 15. Blower Fan Fuse

DANGER:



This fuse has current running through it any time the engine is operating. **THIS FUSE IS NOT** connected to the main circuit breaker **OF** the generator. Attempting to replace the fuse with the engine and/or generator operating could result in **electrocution** and **severe bodily harm**. **ALWAYS** turn the unit completely off before attempting to replace or handle **THIS** fuse



DCA-125USJ (50 HZ)— LOAD APPLICATION

Single Phase Load

Always be sure to check the nameplate on the generator and equipment to insure the wattage, amperage, frequency, and voltage requirements are satisfactorily supplied by the generator for operating the equipment.

Generally, the wattage listed on the nameplate of the equipment is its rated output. Equipment may require 130—150% more wattage than the rating on the nameplate, as the wattage is influenced by the efficiency, power factor and starting system of the equipment.

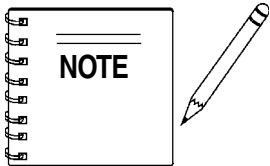

If wattage is not given on the equipment's name plate, approximate wattage may be determined by multiplying nameplate voltage by the nameplate amperage.

$$\text{WATTS} = \text{VOLTAGE} \times \text{AMPERAGE}$$

The power factor of this generator is 0.8. See Table 4 below when connecting loads.

Type Of Load	Power Factor
Single-phase induction motors	0.4 - 0.75
Electric heaters, incandescent lamps	1.0
Fluorescent lamps, mercury lamps	0.4 - 0.9
Electronic devices, communication equipment	1.0
Common power tools	0.8

Current in Amperes	Load In Watts		Maximum Allowable Cable Length			
	At 100 Volts	At 200 Volts	#10 Wire	#12 Wire	#14 Wire	#16 Wire
2.5	300	600	1000 ft.	600 ft.	375 ft.	250 ft.
5	600	1200	500 ft.	300 ft.	200 ft.	125 ft.
7.5	900	1800	350 ft.	200 ft.	125 ft.	100 ft.
10	1200	2400	250 ft.	150 ft.	100 ft.	
15	1800	3600	150 ft.	100 ft.	65 ft.	
20	2400	4800	125 ft.	75 ft.	50 ft.	

CAUTION: Equipment damage can result from low voltage.

Three Phase Load

When calculating the power requirements for 3-phase power use the following equation:

$$\text{KVA} = \frac{\text{VOLTAGE} \times \text{AMPERAGE} \times 1.732}{1000}$$

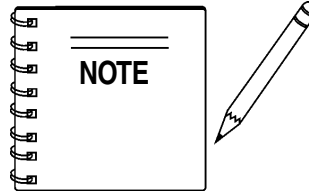

If 3Ø load (kVA) is not given on the equipment nameplate, approximate 3Ø load output may be determined by multiplying voltage by amperage by 1.732.

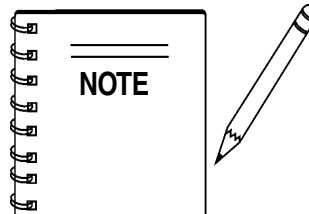

Motors and motor-driven equipment draw much greater current for starting than during operation.

An inadequate size connecting cable which cannot carry the required load can cause a voltage drop which can burn out the appliance or tool and overheat the cable. See Table 5.

- When connecting a resistance load such as an incandescent lamp or electric heater, a capacity of up to the generating set's rated output (kW) can be used.
- When connecting a fluorescent or mercury lamp, a capacity of up to the generating set's rated output (kW) multiplied by 0.6 can be used.
- When connecting an electric drill or other power tools, pay close attention to the required starting current capacity.

When connecting ordinary power tools, a capacity of up to the generating set's rated output (kW) multiplied by 0.8 can be used.

DANGER:



Before connecting this generator to any building's electrical system, a **licensed electrician** must install an **isolation (transfer) switch**. Serious damage to the building's electrical system may occur without this transfer switch.

DCA-125USJ (50 HZ)— GENERATOR OUTPUTS

Voltage Selector Switch

The **voltage selector** switch (Figure 16) is located above the output terminal panel's **Hard Wire Hook-up Panel**. It has been provided for ease of voltage selection.

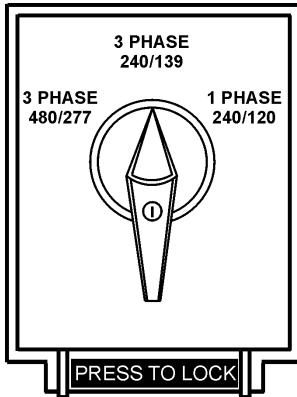

Figure 16. Voltage Selector Switch

Voltage Selector Switch Locking Button

The voltage selector switch has a locking button to protect the generator and load from being switched while the engine is running. To lock the voltage selector switch, **press** and **hold** the **red button** located at the bottom of the switch.

CAUTION:



NEVER change the position of the **voltage selector switch** while the engine is running. **ALWAYS** place circuit breaker in the open position before selecting voltage.

Generator Output Voltages

A wide range of voltages are available to supply voltage for many different applications. Voltages are selected by using the **voltage selector** switch (Figure 15). To obtain some of the voltages as listed in Table 6 (see below) will require a fine adjustment using the **voltage regulator (VR) control knob** located on the control panel.

Table 6. Voltages Available					
Three Phase (Switchable)	200V	220V	240V	416V	440V
Single Phase (Switchable)	115V	127V	139V	240V	254V

Generator Amperage

Table 7 describes the generator's current output capability for both 1 \emptyset -phase and 3 \emptyset phase applications.

Table 7. Generator Ampere Ratings						
DCA-125USJ	kW	kVA	100V	200V	220V	440V
Single Phase	58	N/A	288A x 2	N/A	263A	N/A
Three Phase*	80	100	N/A	288A	288A	131A

* Power Factor = 0.8

How to Read the Output Terminal Gauges.

The gauges and selector switches on the control panel **DO NOT** effect the generator output. They are provided to help observe how much power is being supplied at the **Output terminals lugs**.

Before taking a reading off either gauge, set the **Voltage Selector Switch** (Figure 17) to the position which produces the required voltage (For example, for 3Ø 200V, choose the center 3Ø 240/139V position on the volt- age selector switch.)

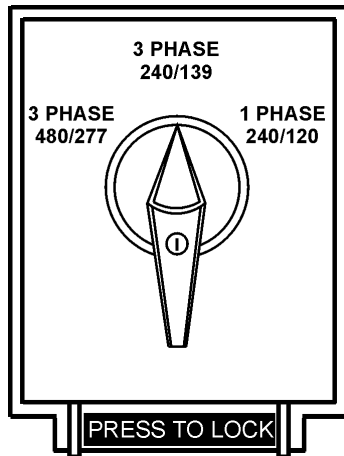
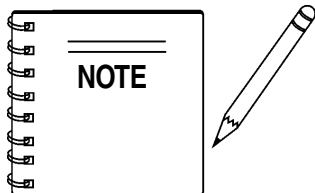

Figure 17. Voltage Selector Switch 240/139V Three Phase Position



For 3Ø 200V/1Ø,115V, place the Voltage Selector Switch in the 3 Phase 240/139 position.

Reading Amperage

To determine the amperage at a terminal lug, set the **AC Ammeter Change-Over Switch** to the appropriate setting (Figure 20) to activate the **AC Ammeter Gauge** (Figure 21) and read the available amperage at the terminal lug.

For example, to measure the amperage at the U terminal lug, set the **AC Ammeter Change-Over Switch** to U and read the **AC Ammeter Gauge**.

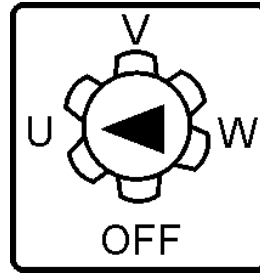

Figure 20. AC Ammeter Change-Over Switch

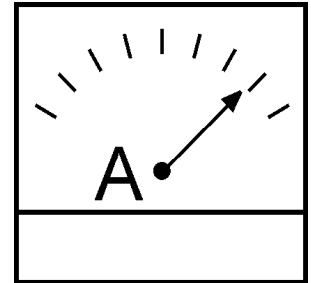
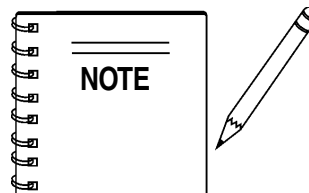

Figure 21. AC Ammeter (Amp reading on U lug)



The **ammeter** gauge will only show a reading when the **Output Terminal Lugs** are connected to a load and in use.

Reading Voltage

To determine the voltage between two terminal lugs, set the **AC Voltmeter Change-Over Switch** to the appropriate setting (Figure 18) to activate the **AC Voltmeter Gauge** (Figure 19) and read the available voltage between the two lugs.

For example, to measure the voltage between the W and U terminal lugs, set the **AC Voltmeter Change-Over Switch** to W-U and read the **AC Voltmeter Gauge**.

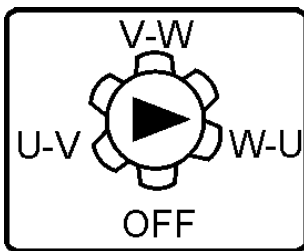

Figure 18. AC Voltmeter Change-Over Switch

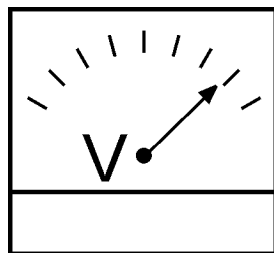

Figure 19. AC Voltmeter Gauge (Volt reading on W-U Lug)

DCA-125USJ (50 HZ)— OUTPUT TERMINAL PANEL CONNECTIONS

UVWO Terminal Output Voltages

Various output voltages can be obtained using the **Output Terminal Lugs**. The voltages at the terminals are dependent on the position of the **Voltage Selector Switch** and the adjustment of the **Voltage Regulator Control Knob**.

Remember the voltage selector switch determines the **range** of the output voltage. The voltage regulator (VR) allows the user to increase or decrease the selected voltage.

3Ø 220/127 Output Terminal Lug Voltages

1. Place the voltage selector switch in the 3Ø 240/139 position as shown in Figure 22.

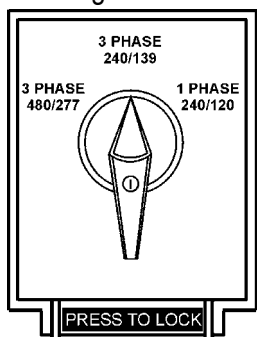

Figure 22. Voltage Selector Switch 240/139V Three-Phase Position

2. Connect the load wires to the **Output Terminal Lugs** as shown in Figure 22.

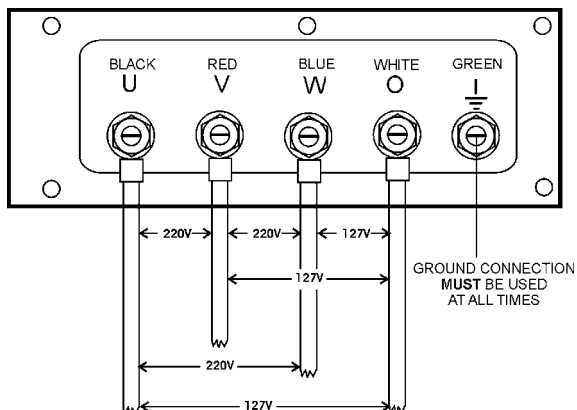

Figure 23. Output Terminal Lugs 3Ø 220/127V Three Phase Connections

3. Turn the voltage regulator knob (Figure 24) clockwise to increase voltage output, turn counterclockwise to decrease voltage output.



Figure 24. Voltage Regulator Knob (139V/240V)

3Ø 200V/1Ø115V Output Terminal Lug Voltages

1. Place the voltage selector switch in the 3Ø 240/139 position as shown in Figure 25.

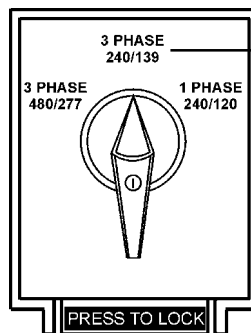

Use this position for 3Ø-200 or 1Ø115V.

Figure 25. Voltage Selector Switch 240/139V Three-Phase Position

2. Connect the load wires to the **Output Terminal Lugs** as shown in Figure 26.

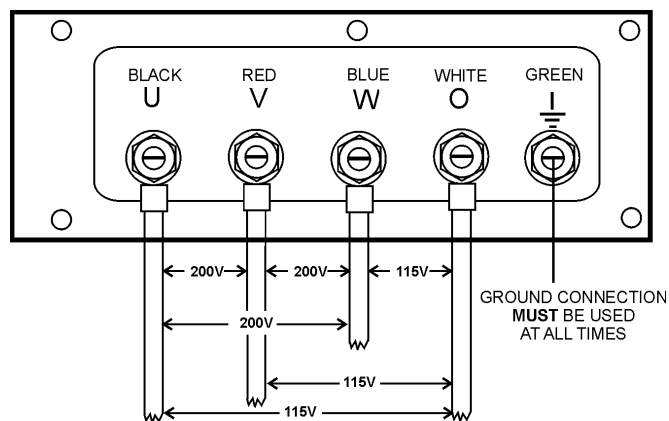
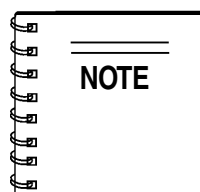

Figure 26. Output Terminal Lugs 3Ø-200V/115V Connections

3. Turn the voltage regulator knob (Figure 24) clockwise to increase voltage output, turn counterclockwise to decrease voltage output.



To achieve a 3Ø 200V output the voltage selector switch must be in the 3Ø-240/139 position and the voltage regulator must be adjusted to 200V.

DCA-125USJ (50 HZ)— OUTPUT TERMINAL PANEL CONNECTIONS

3Ø 440/254 Output Terminal Lug Voltages

1. Place the voltage selector switch in the 3Ø 480/277 position as shown in Figure 27.

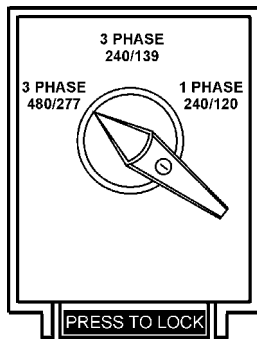

Figure 27. Voltage Selector Switch 480/277V Three-Phase Position

2. Connect the load wires to the **Output Terminal Lugs** as shown in Figure 28.

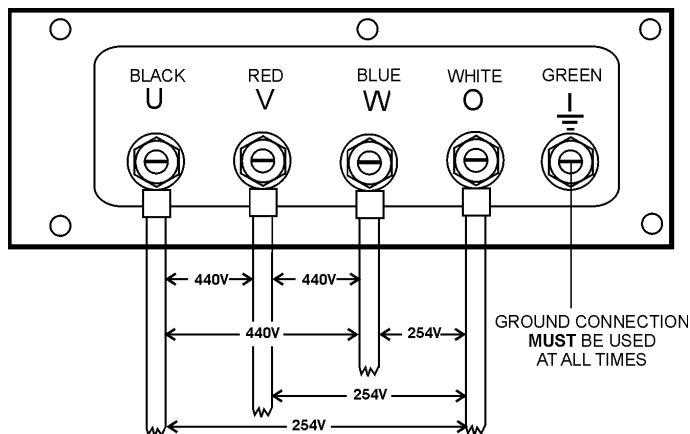

Figure 28. UVWO Terminal Lugs 400/230V Three Phase Connections

3. Turn the voltage regulator knob (Figure 24) clockwise to increase voltage output, turn counterclockwise to decrease voltage output.

1Ø 200V/100V Output Terminal Lug Voltages

1. Place the voltage selector switch in the 1Ø 240/120 position as shown in Figure 29.

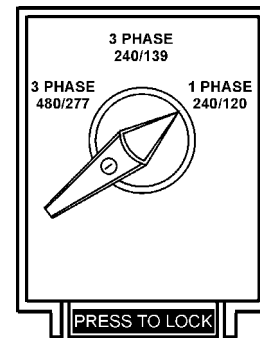

Figure 29. Voltage Selector Switch 240/120V Single-Phase Position

2. Connect the load wires to the **Output Terminal Lugs** as shown in Figure 30.

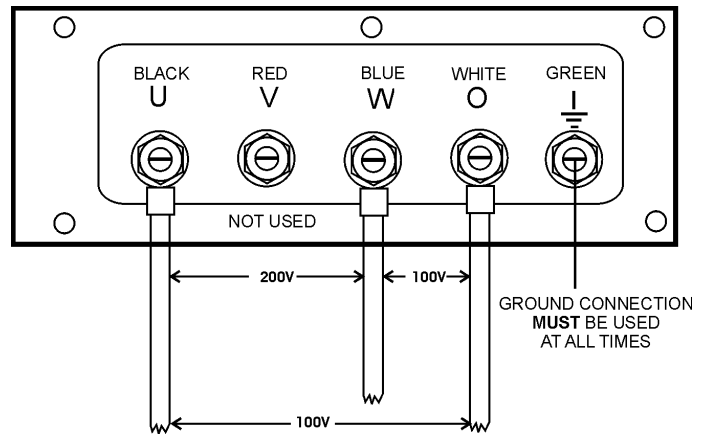

Figure 30. UVWO Terminal Lugs 1Ø-200V/100V Connections

3. Turn the voltage regulator knob (Figure 25) clockwise to increase voltage output, turn counterclockwise to decrease voltage output.

Circuit Breakers

To protect the generator from an overload, a 3-pole, 300 amp, **main** circuit breaker is provided to protect the **U, V, and W Output Terminals** from overload. In addition two single-pole, 20 amp **GFCI** circuit breakers are provided to protect the GFCI receptacles from overload. Three 50 amp **load** circuit breakers have also been provided to protect the auxiliary receptacles from overload. Make sure to switch **ALL** circuit breakers to the **OFF** position prior to starting the engine.

Lubrication Oil

Fill the engine crankcase with lubricating oil through the filler hole, but **DO NOT** overfill. Make sure the generator is level. and verify that the oil level is maintained between the two notches (Figure 31) on the dipstick. See Table 8 for proper selection of engine oil.

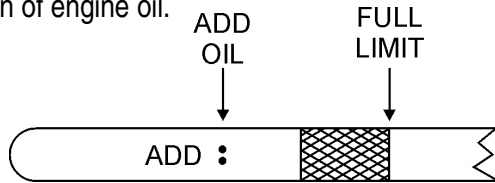

Figure 31. Engine Oil Dipstick

When checking the engine oil, be sure to check if the oil is clean. If the oil is not clean, drain the oil by removing the oil drain plug, and refill with the specified amount of oil as outlined in the **John Deere Engine Owner's Manual**. Oil should be warm before draining.

Other types of motor oils may be substituted if they meet the following requirements:

- API Service Classification CC/SC
- API Service Classification CC/SD
- API Service Classification CC/SE
- API Service Classification CC/SF

°F		°C		OIL: SAE	
122	50				
104	40	10W/40	30	10W/40	
86	30			15W/30	
68	20			10W/30	
50	10			10W	20W/40
32	0				
-14	-10			5W/30	
-4	-20				
-22	-30				
-40	-40			ARCTIC OIL	

Fuel Check

DANGER:



Fuel spillage on a **hot!** engine can cause a **fire** or **explosion**. If fuel spillage occurs, wipe up the spilled fuel completely to prevent fire hazards. **NEVER!** smoke around or near the generator.



Refilling the Fuel System

WARNING:



ONLY properly trained personnel who have read and understand this section should re-fill the fuel tank system.

The generator unit has an internal fuel tank located at the bottom of the cabinet (Figure 32). **ALWAYS** fill the fuel tank with clean and fresh **#2 diesel fuel**. **DO NOT** fill the fuel tanks beyond their capacities.

Pay attention to the fuel tank capacity when replenishing fuel. The fuel tank cap must be closed tightly after filling. Handle fuel in a safety container. If the container does not have a spout, use a funnel. Wipe up any spilled fuel immediately.

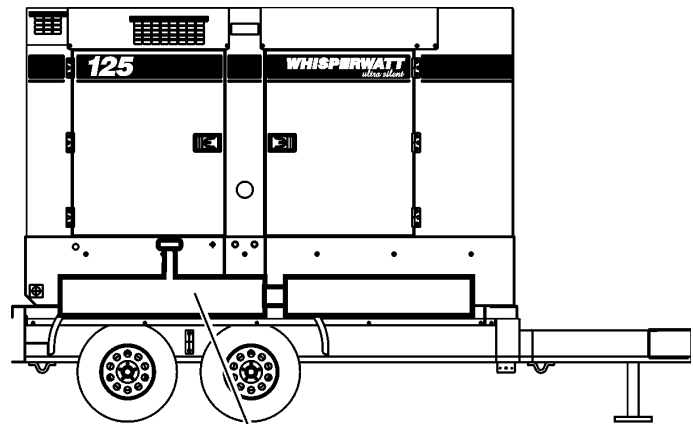

Generator Internal Fuel Tank

Figure 32. Internal Fuel Tank System

Refueling Procedure:

DANGER:



Diesel fuel and its vapors are dangerous to your health and the surrounding environment. Avoid skin contact and/or inhaling fumes.



1. **Level Tanks** – make sure fuel cells are level with the ground. Failure to do so will cause fuel to spill from the tank before reaching full capacity (Figure 33).

WARNING:



ALWAYS! place trailer on firm level ground before refueling.

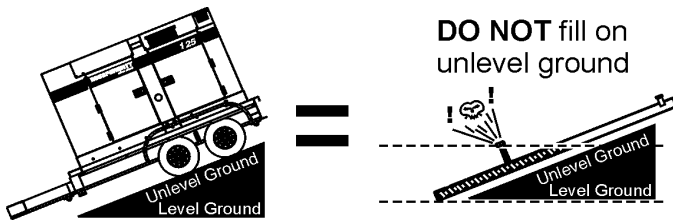
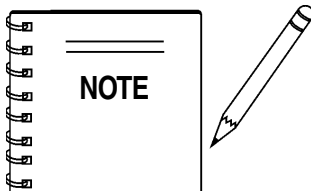

Figure 33. Only Fill on Level Ground



ONLY! use #2 diesel fuel when refueling.

3. Open cabinet doors on the “right side” of the generator (from generator control panel position). Remove fuel cap and fill tank (Figure 34).

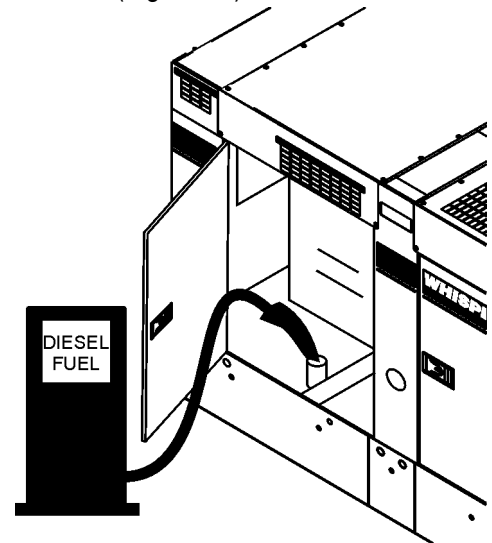

Figure 34. Fueling the Generator

3. **NEVER overfill fuel tank** – It is important to read the fuel gauge when filling trailer fuel tank. **DO NOT** wait for fuel to rise in filler neck (Figure 35).

FUEL GAUGE LOCATED ON CONTROL PANEL

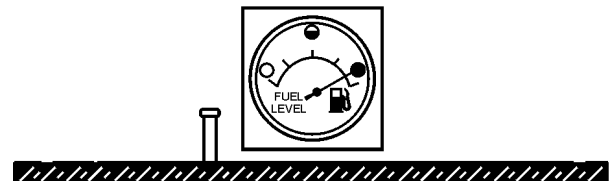

Figure 35. Full Fuel Tank

WARNING:



DO NOT OVER-FILL fuel system. Leave room for fuel expansion. Fuel expands when heated (Figure 36).



Figure 36. Fuel Expansion

Coolant (John Deere Antifreeze/Summer Coolant/Water)

John Deere recommends John Deere Antifreeze/Summer Coolant for use in thier engines, which can be purchased in concentrate (and mixed with 50% demineralized water) or pre-diluted. See the **John Deere Engine Owner's Manual** for further details.

CAUTION:



If adding coolant/antifreeze mix to the radiator, **DO NOT** remove the radiator cap until the unit has completely cooled. The possibility of **hot!** coolant exists which can cause severe burns.

Day-to-day addition of coolant is done from the recovery tank. When adding coolant to the radiator, **DO NOT** remove the radiator cap until the unit has completely cooled. See Table 9 for engine, radiator, and recovery tank coolant capacities. Make sure the coolant level in the recovery tank is always between the "H" and the "L" markings.

Table 9. Coolant Capacity

Engine and Radiator	4.4 Gal. (16.8 liters)
Reserve Tank	2 Quarts (1.9 liters)

Operation Freezing Weather

When operating in freezing weather, be certain the proper amount of antifreeze (Table 10) has been added.

Table 10. Anti-Freeze Operating Temperatures

Vol % Anti-Freeze	Freezing Point	
	°C	°F
50	-37	-34

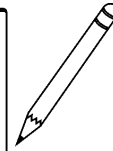
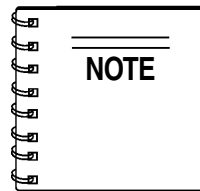

When the antifreeze is mixed with water, the antifreeze mixing ratio **must be** less than 50%.

Cleaning the Radiator

The engine may overheat if the radiator fins become overloaded with dust or debris. Periodically clean the radiator fins with compressed air. Cleaning inside the machine is dangerous, so clean only with the engine turned off and the **negative** battery terminal disconnected.

Air Cleaner

Periodic cleaning/replacement is necessary. Inspect it in accordance with the **John Deere Engine Owner's Manual**.

Fan Belt Tension

A slack fan belt may contribute to overheating, or to insufficient charging of the battery. Inspect the fan belt for damage and wear and adjust it in accordance with the **John Deere Engine Owner's Manual**.

The fan belt tension is proper if the fan belt bends 10 to 15 mm (Figure 37) when depressed with the thumb as shown below.

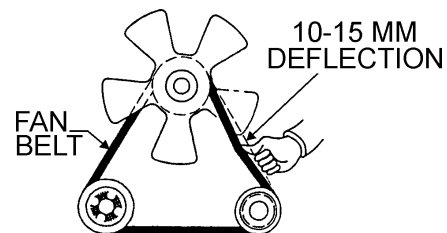

Figure 37. Fan Belt Tension

CAUTION:



NEVER! place hands near the belts or fan while the generator set is running.



Battery

This unit is of negative ground **DO NOT** connect in reverse. Always maintain battery fluid level between the specified marks. Battery life will be shortened, if the fluid level are not properly maintained. Add only distilled water when replenishment is necessary.

DO NOT over fill. Check to see whether the battery cables are loose. Poor contact may result in poor starting or malfunctions. **Always** keep the terminals firmly tightened. Coating the terminals with an approved battery terminal treatment compound. Replace battery with only recommended type battery. The battery type used in this generator is BCI Group 27.

The battery is sufficiently charged if the specific gravity of the battery fluid is 1.28 (at 68° F). If the specific gravity should fall to 1.245 or lower, it indicates that the battery is dead and needs to be recharged or replaced.

Before charging the battery with an external electric source, be sure to disconnect the battery cables.

Battery Cable Installation

ALWAYS be sure the battery cables (Figure 38) are properly connected to the battery terminals as shown below. The **RED** cable is connected to the positive terminal of the battery, and the **BLACK** cable is connected to the negative terminal of the battery.

CAUTION:



ALWAYS disconnect the negative terminal **FIRST** and reconnect negative terminal **LAST**.

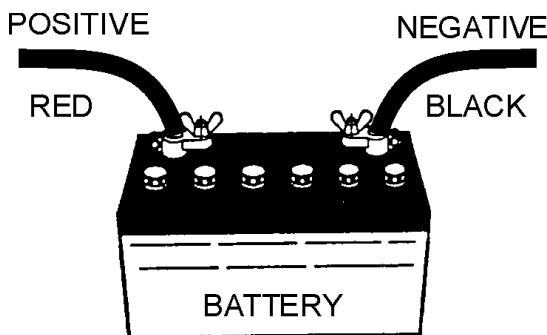
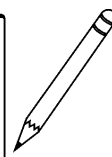
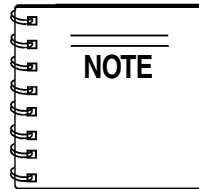

Figure 38. Battery Connections

When connecting battery do the following:

1. **NEVER** connect the battery cables to the battery terminals when the **MPEC Control Switch** is in either the **MANUAL** position. **ALWAYS** make sure that the **MPEC Control Switch** is in the **OFF/RESET** position when connecting the battery.
2. Place a small amount of battery terminal treatment compound around both battery terminals. This will ensure a good connection and will help prevent corrosion around the battery terminals.



If the battery cable is connected incorrectly, electrical damage to the generator will occur. Pay close attention to the polarity of the battery when connecting the battery.

CAUTION:



Inadequate battery connections may cause poor starting of the generator, and create other malfunctions.

Alternator

The polarity of the alternator is negative grounding type. When an inverted circuit connection takes place, the circuit will be in short circuit instantaneously resulting the alternator failure.

DO NOT put water directly on the alternator. Entry of water into the alternator can cause corrosion and damage the alternator.

Wiring

Inspect the entire generator for bad or worn electrical wiring or connections. If any wiring or connections are exposed (insulation missing) replace wiring immediately.

Piping and Hose Connection

Inspect all piping, oil hose, and fuel hose connections for wear and tightness. Tighten all hose clamps and check hoses for leaks.

If any hose (**fuel** or **oil**) lines are defective replace them immediately.

DCA-125USJ (50 HZ)— GENERATOR START-UP PROCEDURE (MANUAL)

WARNING:



The engine's exhaust contains harmful emissions. **ALWAYS have adequate ventilation when operating.** Direct exhaust away from nearby personnel.

Before Starting

CAUTION:



NEVER! manually start the engine with the **main, GFCI** or **auxiliary** circuit breakers in the **ON** (closed) position.

1. Place the **main, G.F.C.I.** and **aux.** circuit breakers (Figure 39) in the **OFF** position prior to starting the engine.

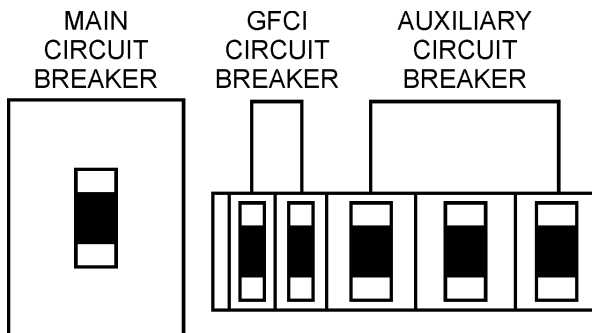
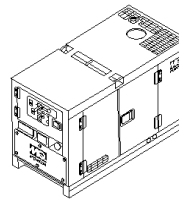

Figure 39. Main, Aux. and GFCI Circuit Breakers (OFF)

2. Connect the load to the **receptacles** or the **Output Terminal Lugs** as shown in Figure 13. These load connection points can be found on the output terminal panel and the output terminal panel's hard wire hookup panel.
3. The output terminal lugs are protected by a plastic cover. Remove this cover to gain access to the terminals. Tighten terminal nuts securely to prevent load wires from slipping out.

4. Close all engine enclosure doors (Figure 40).



CORRECT

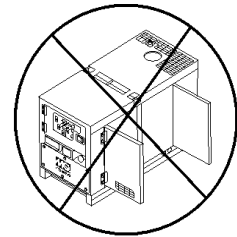

INCORRECT

Figure 40. Engine Enclosure Doors

5. Place the **voltage selector switch** in the desired voltage position (Figure 41).

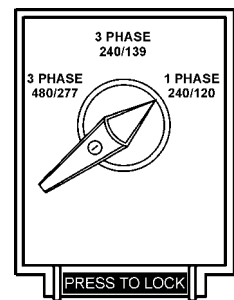

Figure 41. Voltage Selector Switch

DCA-125USJ (50 HZ)— GENERATOR START-UP PROCEDURE (MANUAL)

Starting (Manual)

- Place the **MPEC Control Switch** in the **MANUAL** position to start the engine (Figure 42).

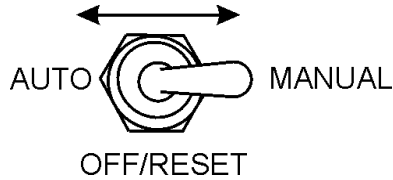

Figure 42. MPEC Control Switch (Manual Position)

In cold weather conditions, placing the **MPEC Control Switch** in the **MANUAL** position will preheat and start the engine **AUTOMATICALLY**. The **Preheat Lamp** (Figure 43) will turn off when the engine has started.

- Once the engine starts, let the engine run for 1-2 minutes. Listen for any abnormal noises.



Figure 43. Pre-Heat Lamp

- Verify that the **Engine Running** status LED on the MPEC unit (Figure 44) is **ON** (lit) after the engine has been started.

Figure 44. Engine Running LED (ON)

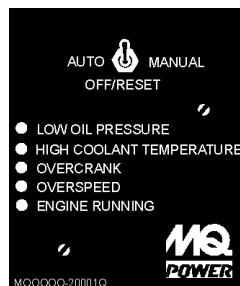

- The generator's frequency meter (Figure 45) should be displaying the 60 cycle output frequency in **HERTZ**.

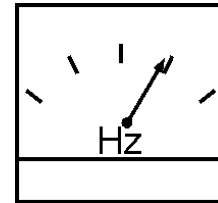

Figure 45. Frequency Meter (Hz)

- The generator's AC-voltmeter (Figure 46) will display the generator's output in **VOLTS**. If the voltage is not within the specified tolerance, use the voltage adjustment control knob (Figure 47) to increase or decrease the desired voltage.

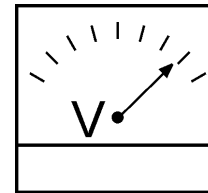

Figure 46. Voltmeter



Figure 47. Voltage Adjust Control Knob

- The ammeter (Figure 48) will indicate zero amps with no load applied. When a load is applied, the ammeter will indicate the amount of current that the load is drawing from the generator.

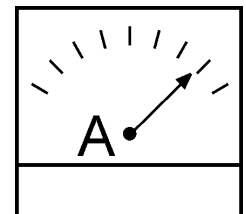

Figure 48. Ammeter (No Load)

DCA-125USJ (50 HZ)— GENERATOR START-UP PROCEDURE (MANUAL)

12. The engine oil pressure gauge (Figure 49) will indicate the oil pressure (kg/ cm²) of the engine. Under normal operating conditions the oil pressure is approximately 35~65 PSI.

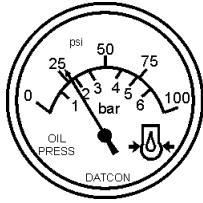

Figure 49. Oil Pressure Gauge

13. The **coolant temperature gauge** (Figure 50) will indicate the coolant temperature. Under normal operating conditions the coolant temperature should be between 165 and 215 degrees Fahrenheit (**Green Zone**).

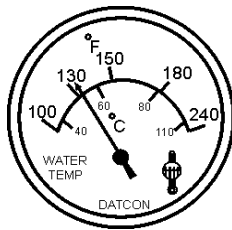

Figure 50. Coolant Temperature Gauge

14. The **tachometer gauge** (Figure 51) will indicate the speed of the engine when the generator is operating. Under normal operating conditions this speed is approximately 1500 RPM's.

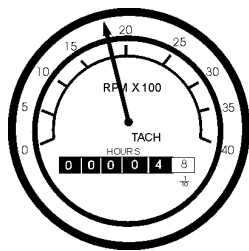

Figure 51. Engine Tachometer Gauge

15. Place the **main**, **GFCI**, and **aux.** circuit breakers in the **ON** position (Figure 52).

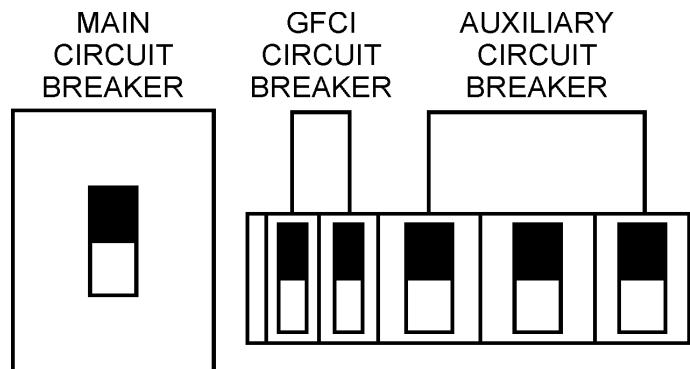

Figure 52. Main, Aux. and GFCI Circuit Breakers (ON)

16. Observe the generator's ammeter (Figure 53) and verify it reads the anticipated amount of current with respect to the load. The ammeter will only display a current reading if a load is in use.

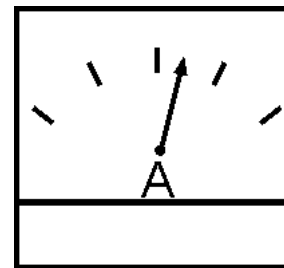

Figure 53. Ammeter (Load)

17. The generator will run until manually stopped or an abnormal condition occurs.

DCA-125USJ (50 HZ)— GENERATOR START-UP PROCEDURE (AUTO MODE)

DANGER:



Before connecting this generator to any building's electrical system, a **licensed electrician** must install an **isolation (transfer) switch**. Serious damage to the building's electrical system may occur without this transfer switch.



CAUTION:



When connecting the generator to a isolation (transfer) switch, **ALWAYS** have power applied to the generator's internal battery charger. This will ensure that the engine will not fail due to a dead battery.

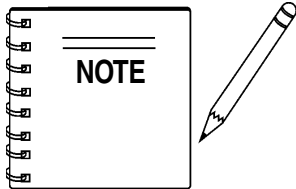

When the generator is set in the **AUTO** mode, the generator will **automatically start** in the event of commercial power falling below a prescribed level by means of a contact closure that is generated automatically by a transfer switch.

WARNING:



When running the generator in the **AUTO** mode, remember the generator can start up at any time without warning. **NEVER** attempt to perform any maintenance when the generator is in the auto mode.

1. Perform steps 1 through 5 in the **Before Starting** section as outlined in the **Manual Starting Procedure**.

Starting (Auto Mode)

2. Place the **MPEC Control Switch** (Figure 54) in the **AUTO** position .

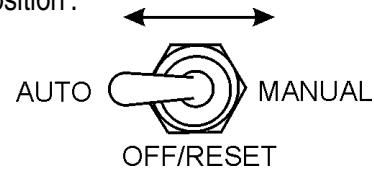

Figure 54. MPEC Control Switch (AUTO)

3. Continue to follow the steps outlined in the **Manual Start-up** procedure (start at step 9).

DCA-125USJ (50 HZ)— GENERATOR SHUT-DOWN PROCEDURE

CAUTION:



NEVER stop the engine suddenly except in an emergency. **DO NOT** use the emergency stop switch as a method of shutting down the generator. This switch is **ONLY** to be used in the event of an emergency.

Emergency Shutdown Procedure

1. To shut-down the engine in the event of an emergency, switch the **MAIN**, **GFCI** and **LOAD** (Figure 39) circuit breakers to **OFF** position.
2. Place the **MPEC Control Switch** (Figure 55) to the **OFF/RESET** position.

Shutdown Procedure

To shutdown the generator use the following procedure:

1. Place both the **MAIN**, **GFCI** and **LOAD** circuit breakers as shown in Figure 39 to the **OFF** position.
3. Let the engine cool by running it for 3-5 minutes with no load applied.
4. Place the **MPEC Control Switch** (Figure 55) to the **OFF/RESET** position.



Figure 55. MPEC Control Switch (Off/Reset)

5. Verify that the **all** status LED on the MPEC display are **OFF** (not lit).
6. Remove all loads from the generator.

TABLE 11. INSPECTION/MAINTENANCE		10 Hrs DAILY	250 Hrs	500 Hrs	1000 Hrs
ENGINE	Check Engine Fluid Levels	X			
	Check Air Cleaner	X			
	Check Battery Acid Level	X			
	Check Fan Belt Condition	X			
	Check for Leaks	X			
	Check for Loosening of Parts	X			
	Replace Engine Oil and Filter * 1		X		
	Clean Air Filter		X		
	Check Fuel Filter/Water Separator Bowl	X			
	Clean Unit, Inside and Outside		X		
	Change Fuel Filter			X	
	Clean Radiator and Check Coolant Protection Level*2			X	
	Replace Air Filter Element * 3			X	
	Check all Hoses and Clamps * 4				X
	Clean Inside of Fuel Tank				X
GENERATOR	Measure Insulation Resistance Over 3M ohms		X		
	Check Rotor Rear Support Bearing			X	

*1 Replace engine oil and filter at 100 hours, first time only.

*2 Add "Supplemental Coolant Additives (SCA'S)" to recharge the engine coolant.

*3 Replace primary air filter element when restriction indicator shows a vacuum of 625 mm (25 in. H₂O).

*4 If blowby hose needs to be replaced, ensure that the slope of the blowby hose is at least a 1/2 inch per foot, with no sags or dips that could collect moisture and/or oil.

General Inspection

Prior to each use, the generator should be cleaned and inspected for deficiencies. Check for loose, missing or damaged nuts, bolts or other fasteners. Also check for fuel, oil, and coolant leaks.

Engine Side (Refer to the Engine Instruction Manual). Use Table 11 as a general maintenance guideline

Air Cleaner

Every 250 hours: Remove air cleaner element and clean the heavy duty paper element with light spray of compressed air. Replace the air cleaner as needed.

Air Cleaner with Dust Indicator

This indicator is attached to the air cleaner. When the air cleaner element is clogged, air intake restriction becomes greater and the dust indicator signal shows **RED** meaning the element needs changing or service. After changing the air element, press the dust indicator button to reset the indicator.

Service Daily

If the engine is operating in very **dusty** or **dry grass** conditions, a clogged air cleaner will result. This can lead to a loss of power, excessive carbon buildup in the combustion chamber and high fuel consumption. Change air cleaner more **frequently** if these conditions exist.

Fuel Addition

Add diesel fuel (the grade may vary according to season and locations).

Removing Water from the Fuel Tank

After prolonged use, water and other impurities accumulate in the bottom of the tank. Occasionally inspect the fuel tank for water contamination and drain the contents if required.

During cold weather, the more empty volume inside the tank, the easier it is for water to condense. This can be reduced by keeping the tank full with diesel fuel.

Air Removal

If air enters the fuel injection system of a diesel engine, starting becomes impossible. After running out of fuel, or after disassembling the fuel system, bleed the system according to the following procedure. See the *John Deere Engine Manual* for details.

Check Oil Level

Check the crankcase oil level prior to each use, or when the fuel tank is filled. Insufficient oil may cause severe damage to the engine. Make sure the generator is level. The oil level must be between the two notches on the dipstick as shown in Figure 33.

Replacing Oil Filter

- Remove the old oil filter.
- Apply a film of oil to the gasket on the new oil filter.
- Install the new oil filter.
- After the oil cartridge has been replaced, the engine oil will drop slightly. Run the engine for a while and check for leaks before adding more oil if needed. Clean excessive oil from engine.

Replacing Fuel Filter

- Replace the fuel filter cartridge with new one every 500 hours or so.
- Loosen the drain plug at the lower top of the fuel filter. Drain the fuel in the fuel body together with the mixed water. **DO NOT** spill the fuel during disassembly.
- Vent any air.

Flushing Out Radiator and Replacing Coolant

- Open both cocks located at the crankcase side and at the lower part of the radiator and drain coolant. Open the radiator cap while draining. Remove the overflow tank and drain.
- Check hoses for softening and kinks. Check clamps for signs of leakage.
- Flush the radiator by running clean tap water through radiator until signs of rust and dirt are removed. **DO NOT** clean radiator core with any objects, such as a screwdriver.
- Tighten both cocks and replace the overflow tank.
- Replace with coolant as recommended by the engine manufacturer.
- Close radiator cap tightly.

CAUTION:



Allow engine to **cool** when flushing out radiator. Flushing the radiator while hot could cause serious burns from water or steam.



Generator Storage

For long term storage of the generator the following is recommended:

- Fill the fuel tank completely. Treat with a fuel stabilizer if necessary.
- Completely drain the oil from the crankcase and refill if necessary with fresh oil.
- Clean the entire generator, internal and external.
- Cover the generating set and store in a clean, dry place.
- Disconnect the battery.
- Make sure engine coolant is at proper level.
- If generator is mounted on a trailer, jack trailer up and place on blocks so tires do not touch the ground or block and completely remove the tires.

DCA-125USJ (50 HZ)—TRAILER BRAKES MAINTENANCE

Brakes

Trailer brakes should be inspected the **first 200 miles** of operation. This will allow the brake shoes and drums to seat properly. After the first 200 mile interval, inspect the brakes **every 3,000 miles**. If driving over rough terrain, inspect the brakes more frequently.

Figure 56 displays the major hydraulic surge brake components that will require inspection and maintenance. Please inspect these components as required using steps 1 through 8 as listed below:

Brake Adjustment

1. Place the trailer on jack stands. Make sure the jack stands are placed on secure level ground.
2. Check the wheel and drum for free rotation.
3. Remove the adjusting hole cover from the adjusting slot at the bottom brake backing plate.
4. With a screwdriver or standard adjusting tool, rotate the star wheel of the adjuster assembly to expand the brake shoes.
5. Adjust the brake shoes outward until the pressure of the lining against the wheel drum makes the wheel difficult to turn.
6. Adjust, rotate the star wheel in the opposite direction until the wheel rotates freely with slight lining drag.
7. Replace the adjusting hole cover and lower the trailer to the ground.
8. Repeat steps 1 through 7 on the remaining brakes.

Hydraulic Surge Brakes

Hydraulic surge brakes (Figure 56) should not require any special attention with the exception of routine maintenance such as shoe and lining replacement. Brake lines should be periodically checked for cracks, kinks, or blockage.

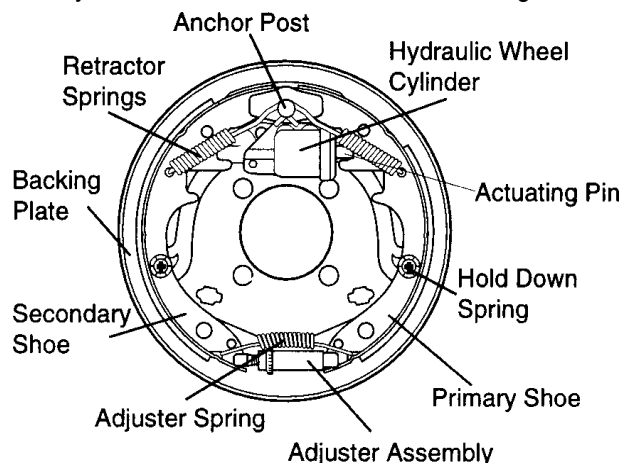

Figure 56. Hydraulic Brake Components

Actuator

Hydraulic surge braking requires the installation of an actuator at the tongue of the trailer. Remember the **surge** or **push** of the trailer toward the tow vehicle automatically synchronizes the trailer brakes with the tow vehicle brakes. As the trailer pushes against the tow vehicle the actuator telescopes together and applies force to the master cylinder, supplying hydraulic pressure to the trailer brakes.

Periodically check and test the surge "**actuator**" to make sure that it is functioning correctly. Never use an undersize actuator.

Table 12. Hydraulic Brake Troubleshooting

Symptom	Possible Cause	Solution
No Brakes	Brake line broken or kinked?	Repair or replace.
Weak Brakes or Brakes Pull to One Side	Brake lining glazed?	Reburnish or replace.
	Trailer overloaded?	Correct weight.
	Brake drums scored or grooved?	Machine or replace.
	Tire pressure correct?	Inflate all tires equally.
	Tires unmatched on the same axle?	Match tires.
Locking Brakes	Brake components loose, bent or broken?	Replace components.
	Brake drums out-of-round?	Replace.
Noisy Brakes	System lubricated?	Lubricate.
	Brake components correct?	Replace and correct.
Dragging Brakes	Brake lining thickness incorrect or not adjusted correctly?	Install new shoes and linings.
	Enough brake fluid or correct fluid?	Replace rubber parts fill with dot 4 fluid.

DCA-125USJ (50 HZ)—TRAILER MAINTENANCE

Tires/Wheels/Lug Nuts

Tires and wheels are a very important and critical components of the trailer. When specifying or replacing the trailer wheels it is important the wheels, tires, and axle are properly matched.

CAUTION:



DO NOT attempt to repair or modify a wheel. **DO NOT** install in

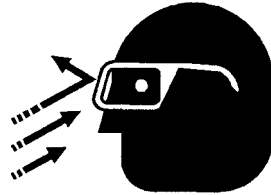

inner tube to correct a leak through the rim. If the rim is cracked, the air pressure in the inner tube may cause pieces of the rim to explode (break off) with great force and cause serious eye or bodily injury.

Tire Wear/Inflation

Tire inflation pressure is the most important factor in tire life. Pressure should be checked cold before operation **DO NOT** bleed air from tires when they are *hot!* Check inflation pressure weekly during use to insure the maximum tire life and tread wear.

Table 10 (Tire Wear Troubleshooting) will help pinpoint the causes and solutions of tire wear problems.

TABLE 13. TIRE WEAR TROUBLESHOOTING		
WEAR PATTERN	CAUSE	SOLUTION
Center Wear	Over Inflation.	Adjust pressure to particular load per tire manufacturer.
Edge Wear	Under Inflation.	Adjust pressure to particular load per tire manufacturer.
Side Wear	Loss of camber or overloading.	Make sure load does not exceed axle rating. Align wheels.
Toe Wear	Incorrect toe-in.	Align wheels.
Cupping	Out-of-balance.	Check bearing adjustment and balance tires.
Flat Spots	Wheel lockup & tire skidding.	Avoid sudden stops when possible and adjust brakes.

CAUTION:



ALWAYS wear safety glasses when removing or installing force fitted parts. Failure to comply may result in serious injury.

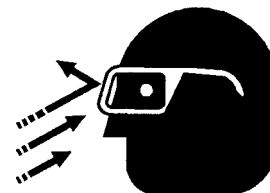

Suspension

The *leaf suspension* springs and associated components (Figure 57) should be visually inspected every 6,000 miles for signs of excessive wear, elongation of bolt holes, and loosening of fasteners. Replace all damaged parts (suspension) immediately. Torqued suspension components as detailed in Table 14.

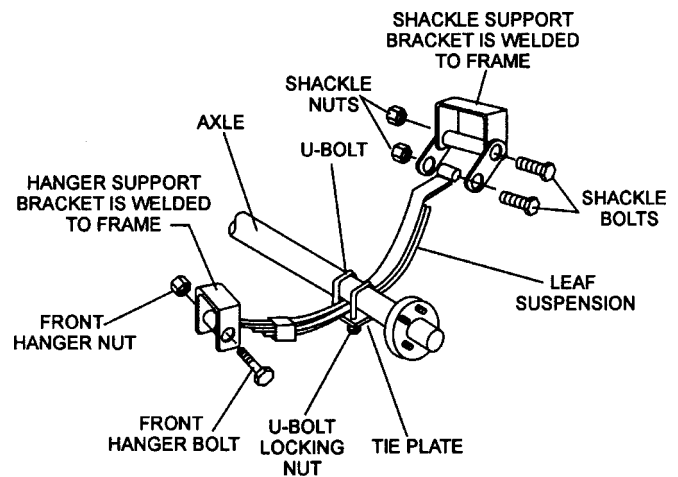

Figure 57. Major Suspension Components

Table 14. Suspension Torque Requirements

Item	Torque (Ft.-Lbs.)
3/8" U-BOLT	MIN-30 MAX-35
7/16" U-BOLT	MIN-45 MAX-60
1/2" U-BOLT	MIN-45 MAX-60
SHACKLE BOLT SPRING EYE BOLT	SNUG FIT ONLY. PARTS MUST ROTATE FREELY. LOCKING NUTS OR COTTER PINS ARE PROVIDED TO RETAIN NUT-BOLT ASSEMBLY.
SHOULDER TYPE SHACKLE BOLT	MIN-30 MAX-50

DCA-125USJ (50 HZ)—TRAILER MAINTENANCE

Lug Nut Torque Requirements

It is extremely important to apply and maintain proper wheel mounting torque on the trailer. Be sure to use only the fasteners matched to the cone angle of the wheel. Proper procedure for attachment of the wheels is as follows:

1. Start all wheel lug nuts by hand.
2. Torque all lug nuts in sequence (see Figure 58). **DO NOT** torque the wheel lug nuts all the way down. Tighten each lug nut in 3 separate passes as defined by Table 15.
3. After first road use, retorque all lug nuts in sequence. Check all wheel lug nuts periodically.

Table 15. Tire Torque Requirements

Wheel Size	First Pass FT-LBS	Second Pass FT-LBS	Third Pass FT-LBS
12"	20-25	35-40	50-65
13"	20-25	35-40	50-65
14"	20-25	50-60	90-120
15"	20-25	50-60	90-120
16"	20-25	50-60	90-120

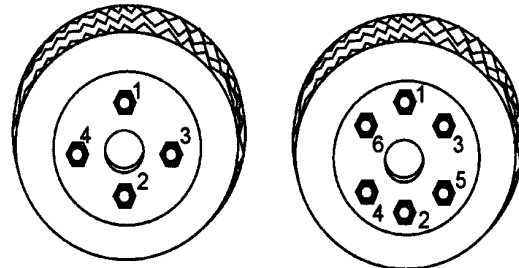

4-LUG NUTS

6-LUG NUTS

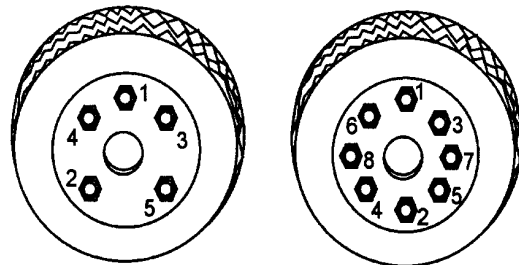

5-LUG NUTS

8-LUG NUTS

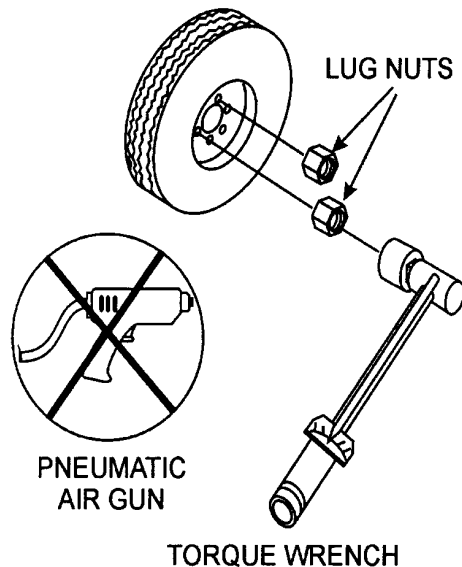
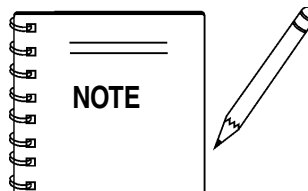

Figure 59. Wheel Lug Nuts Tightening Sequence



NEVER use an pneumatic air gun to tighten wheel lug nuts.

DCA-125USJ (50 HZ)—TRAILER WIRING DIAGRAM

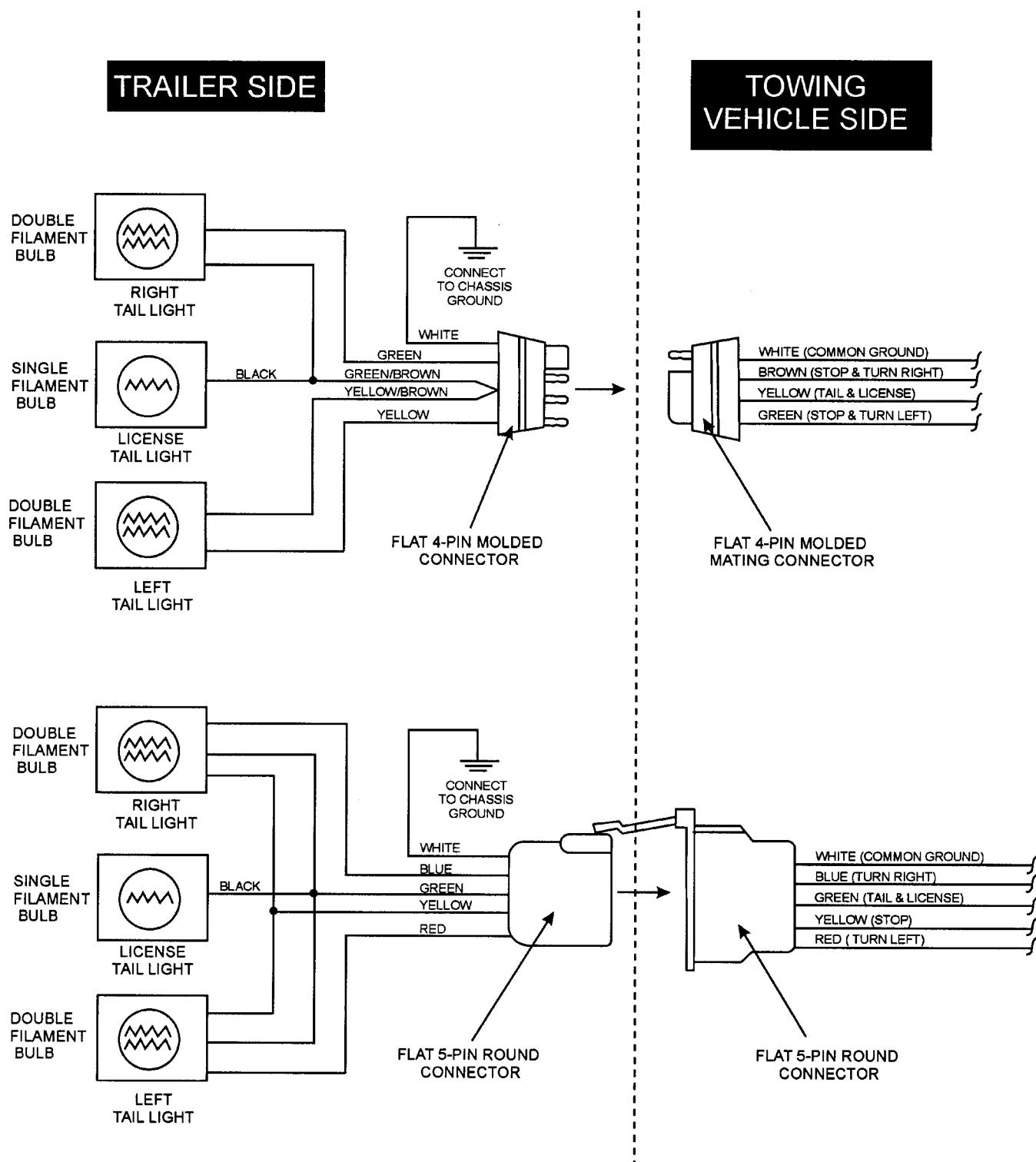
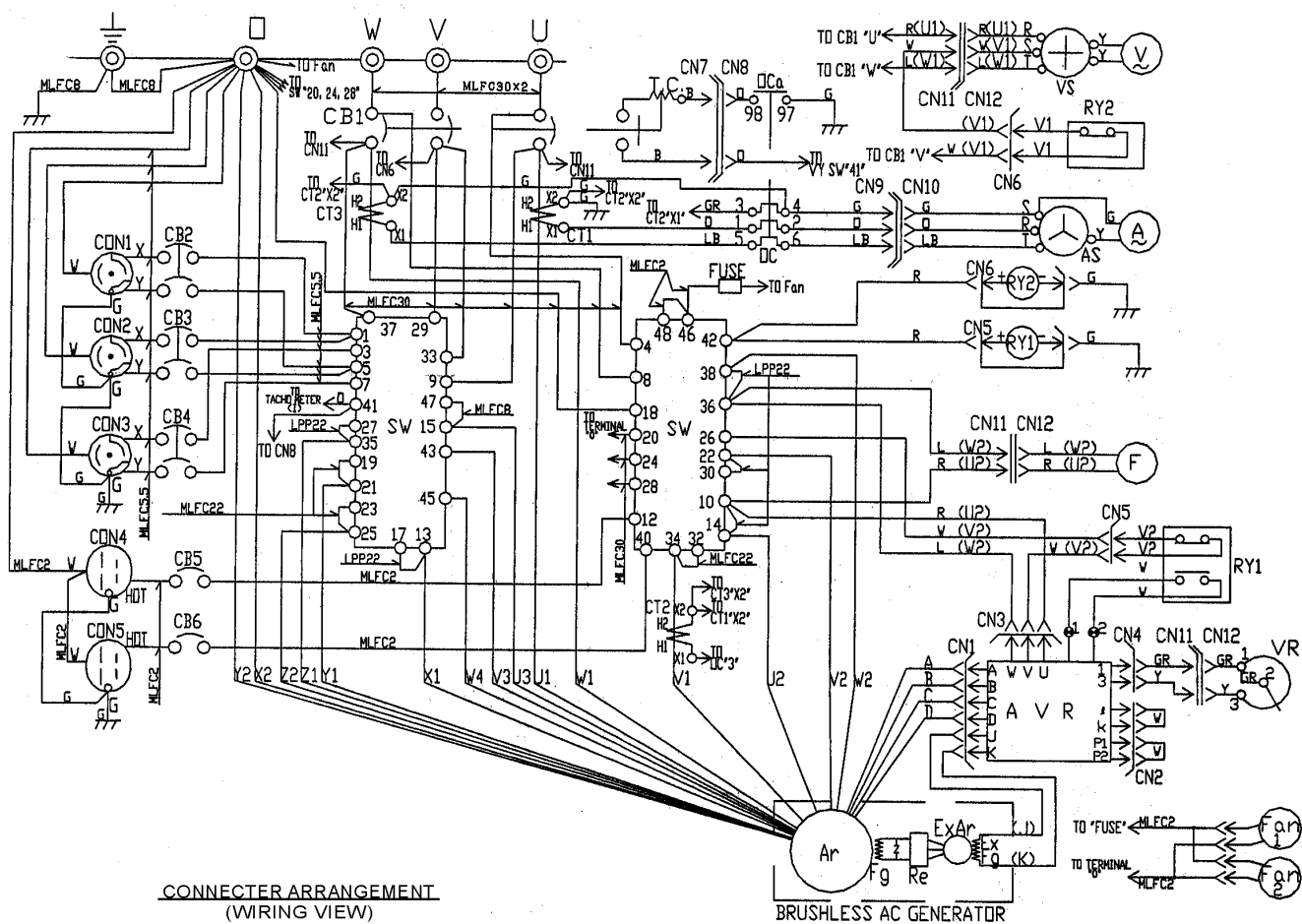
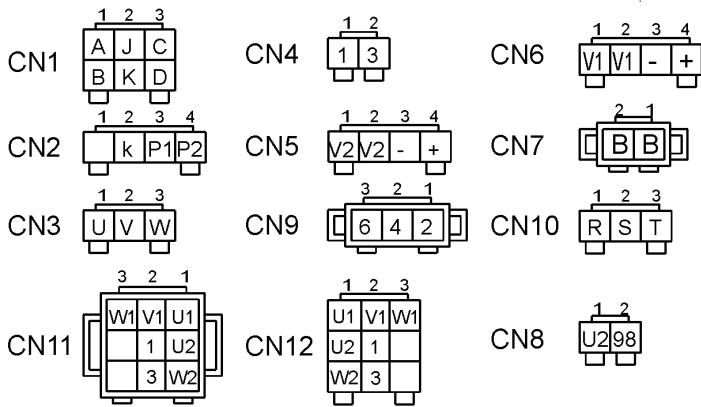

Figure 59. Trailer/Towing Vehicle Wiring Diagram

DCA-125USJ (50 HZ)— GENERATOR WIRING DIAGRAM



CONNECTER ARRANGEMENT
(WIRING VIEW)



COLOR CODE			
SYM.	WIRE COLOR	SYM.	WIRE COLOR
B	BLACK	R	RED
L	BLUE	W	WHITE
BR	BROWN	Y	YELLOW
G	GREEN	LB	LIGHT BLUE
GR	GRAY	LG	LIGHT GREEN
V	VIOLET	O	ORANGE
P	PINK		

Notice :

1. No designation lead size : 1.25

SYMBOL	DESIGNATION
Ar	MAIN GENERATOR ARMATURE WINDING
Fg	MAIN GENERATOR FIELD WINDING
ExAr	EXCITER ARMATURE WINDING
ExFg	EXCITER FIELD WINDING
Re	RECTIFIER
AVR	AUTOMATIC VOLTAGE REGULATOR
VR	VOLTAGE REGULATOR (RHEOSTAT)
CT 1,2,3	CURRENT TRANSFORMER
AS	CHANGE-OVER SWITCH, AMMETER
A	AC, AMMETER
VS	CHANGE-OVER SWITCH, VOLTMETER
V	AC, VOLTMETER
F	FREQUENCY METER
CB1	CIRCUIT BREAKER
CB2,3,4	CIRCUIT BREAKER
CB5,6	CIRCUIT BREAKER
CN1,2,3	RECEPTACLE
CN4,5	RECEPTACLE
OC	OVER CURRENT RELAY
SW	SELECTOR SWITCH
RY1,2	RELAY UNIT
FUSE	10A
FAN 1,2	FAN MOTOR

Figure 60. Generator Wiring Diagram

DCA-125USJ (50 HZ)—ENGINE WIRING DIAGRAM

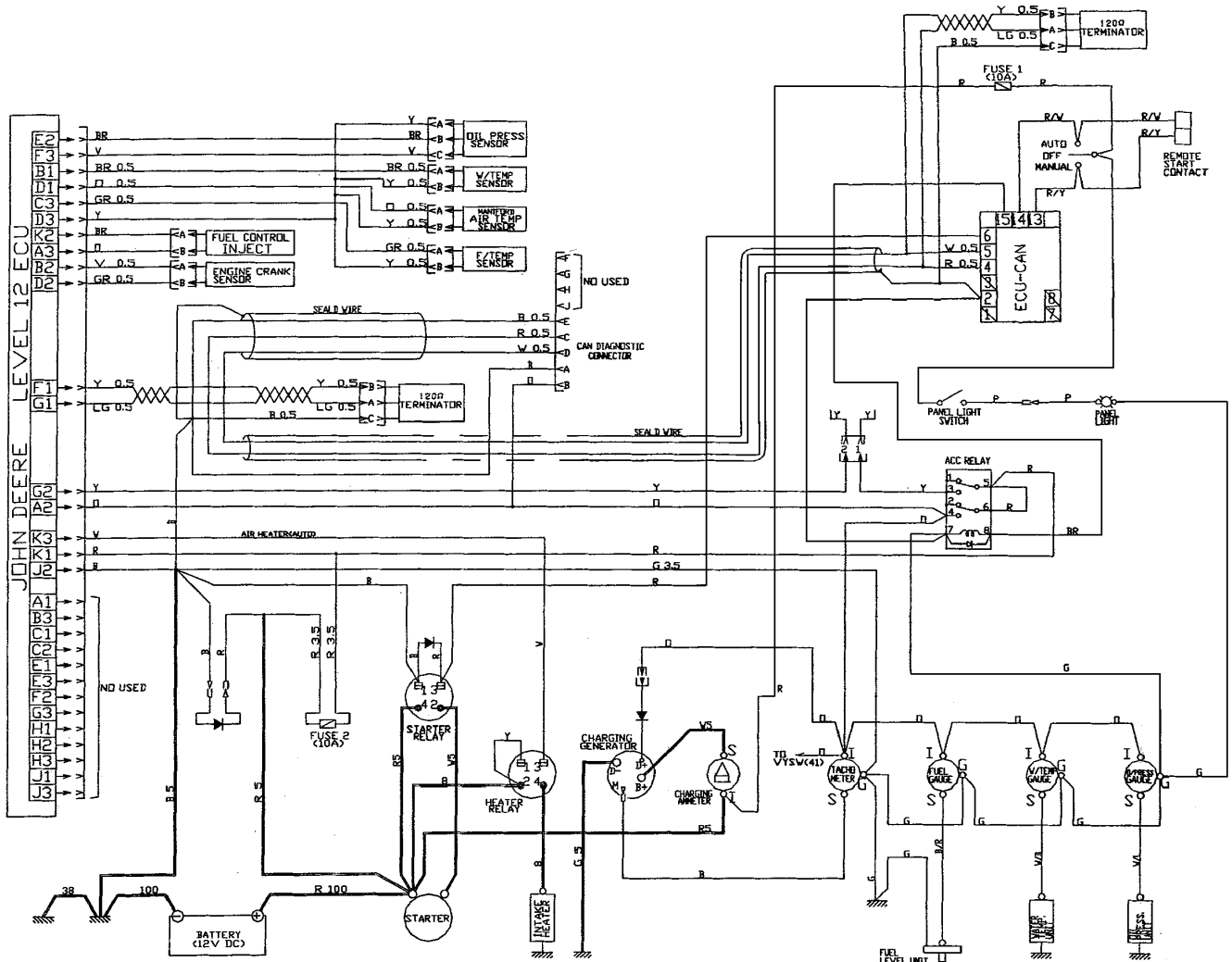

JOHN DEERE LEVEL 12 ECU CONNECTOR

CAN DIAGNOSTIC CONNECTOR

CAN TERMINATOR

CRANK SENSOR

COOLANT TEMP.

INTAKE HEATER WAIT LAMP (LAMP SIDE)

MGP (A CONNECTOR FORM IS MALE FEMALE COMMONNESS)

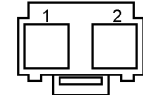
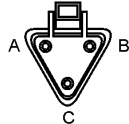
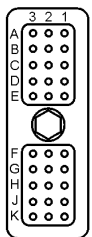

ALTERNATOR

120 OHM TERMINATOR

FUEL TEMP.

MANIFOLD AIR TEMP.

INTAKE HEATER WAIT LAMP (WIRING SIDE)

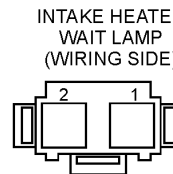
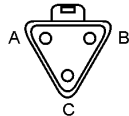

Figure 61. Engine Wiring Diagram

COLOR CODE			
SYM.	WIRE COLOR	SYM.	WIRE COLOR
B	BLACK	R	RED
L	BLUE	W	WHITE
BR	BROWN	Y	YELLOW
G	GREEN	LB	LIGHT BLUE
GR	GRAY	LG	LIGHT GREEN
V	VIOLET	O	ORANGE
P	PINK		

WIRE SIZE	
100:KIV or MLFC	100 mm ²
38:KIV or MLFC	38 mm ²
8:KIV or MLFC	8 mm ²
5:DESIGNATED COLOR	AV 5 mm ²
3.5:DESIGNATED COLOR	AV 3.5 mm ²
0.5:DESIGNATED COLOR	AV 0.5 mm ²
WITH NO DESIGNATION, USE AV	
1.25 mm ² LEAD OF DESIGNATED COLOR	

DCA-125USJ (50 HZ)—TROUBLESHOOTING (GENERATOR)

Practically all breakdowns can be prevented by proper handling and maintenance inspections, but in the event of a breakdown, use Table 16 shown below for diagnosis of the Generator. If the problem cannot be remedied, consult our company's business office or service plant.

TABLE 16. GENERATOR TROUBLESHOOTING

SYMPTOM	POSSIBLE PROBLEM	SOLUTION
No Voltage Output	AC Voltmeter defective?	Check output voltage using a voltmeter.
	Is wiring connection loose?	Check wiring and repair.
	Is AVR defective?	Replace if necessary.
	Defective Rotating Rectifier?	Check and replace.
	Defective Exciter Field?	Check for 17.3 ohms across J & K on CN1
Low Voltage Output	Is engine speed correct?	Turn engine throttle lever to "High".
	Is wiring connections loose?	Check wiring and repair.
	Defective AVR?	Replace if necessary.
High Voltage Output	Is wiring connections loose?	Check wiring and repair.
	Defective AVR?	Replace if necessary.
Circuit Breaker Tripped	Short Circuit in load?	Check load and repair.
	Over current?	Confirm load requirements and reduce.
	Defective circuit breaker?	Check and replace.
	Over current Relay actuated?	Confirm load requirement and replace.

DCA-125USJ (50 HZ)—TROUBLESHOOTING (ENGINE CONTROLLER)

Practically all breakdowns can be prevented by proper handling and maintenance inspections, but in the event of a breakdown, use Table 17 (Engine Controller Troubleshooting) as a basic guideline for troubleshooting the Microprocessor Engine Controller unit (MPEC). If the problem cannot be remedied, consult our company's business office or service plant.

TABLE 17. ENGINE CONTROLLER TROUBLESHOOTING

Sympton	Possible Cause	Solution
Low oil pressure light is on.	Low oil level?	Fill oil level.
	Oil pressure sending unit failure?	Replace oil pressure sending unit.
	Time delay malfunction in Controller?	Refer to dealer.
	Wire shorted?	Inspect/repair wire.
Low coolant level light is on.	Low coolant level?	Fill coolant level.
	Sending unit failure?	Replace sending unit.
	Low battery voltage?	Replace/charge battery.
High coolant temperture light is on.	Fan belt tension incorrect?	Tighten/replace fan belt.
	Air flow is not circulation through radiator?	Clean/repair radiator grill.
	Doors open?	Close doors.
	Exhaust leaking?	Replace/repair gaskets or faulty part.
	Generator being overloaded?	Check/reduce load.
	Thermostat failure?	Replace thermostat.
	Air intake blocked?	Clear all air intakes.
	Temperature switch failure?	Replace temperature switch.
Overcrank light is on.	No or low Fuel?	Fill fuel level.
	Controller needs to be calibrated?	Refer to dealer.
Overspeed light is on.	RPM engine speed too high?	Adjust RPM.
	Governor actuator needs to be adjusted?	Adjust governor actuator.
	Governor controller needs to be adjusted?	Adjust governor controller.
	Engine Controller needs to be calibrated?	Refer to dealer.
Loss of MPU light(s) or on.	Magnetic pick up out of adjustment?	Adjust magnetic pick up.
	Magnetic pick up dirty?	Clean magnetic pick up.

EXPLANATION OF CODE IN REMARKS COLUMN

How to read the marks and remarks used in this parts book.

Items Found In the “Remarks” Column

Serial Numbers-Where indicated, this indicates a serial number range (inclusive) where a particular part is used.

Model Number-Where indicated, this shows that the corresponding part is utilized only with this specific model number or model number variant.

Items Found In the “Items Number” Column

All parts with same symbol in the number column, *, #, +, %, or <, belong to the same assembly or kit

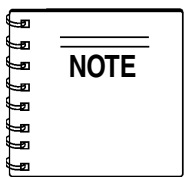

If more than one of the same reference number is listed, the last one listed indicates newest (or latest) part available.

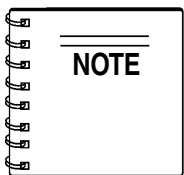

The contents of this catalog are subject to change without notice.

DCA-125USJ (50 HZ)— SUGGESTED SPARE PARTS

DCA-125USJ (50 HZ)W/JOHN DEERE 4045TF275 DIESEL ENGINE 1 TO 3 UNITS

<u>Qty.</u>	<u>P/N</u>	<u>Description</u>
5	0602041292	FILTER, OIL
5	0602042594	FILTER, FUEL, PRIMARY
5	0602042595	FILTER, FUEL, FINAL
3	0602046377	ELEMENT, AIR
1	0602011493	BELT, FAN
1	0605505070	CAP. FUEL TANK
1	0602122272	UNIT, OIL PRESSURE
1	0602123261	UNIT, WATER TEMPERATURE
2	0601802149	FUSE, 10A
1	1518183040	SENDER, WATER SWITCH (ENGINE SIDE)
1	1718939010	SENDER, OIL SWITCH (ENGINE SIDE)

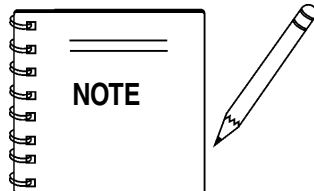

Part number on this Suggested Spare Parts list may supercede/replace the P/N shown in the text pages of this book.

DCA-125USJ (50 HZ)— GENERATOR ASSY.

GENERATOR ASSY.

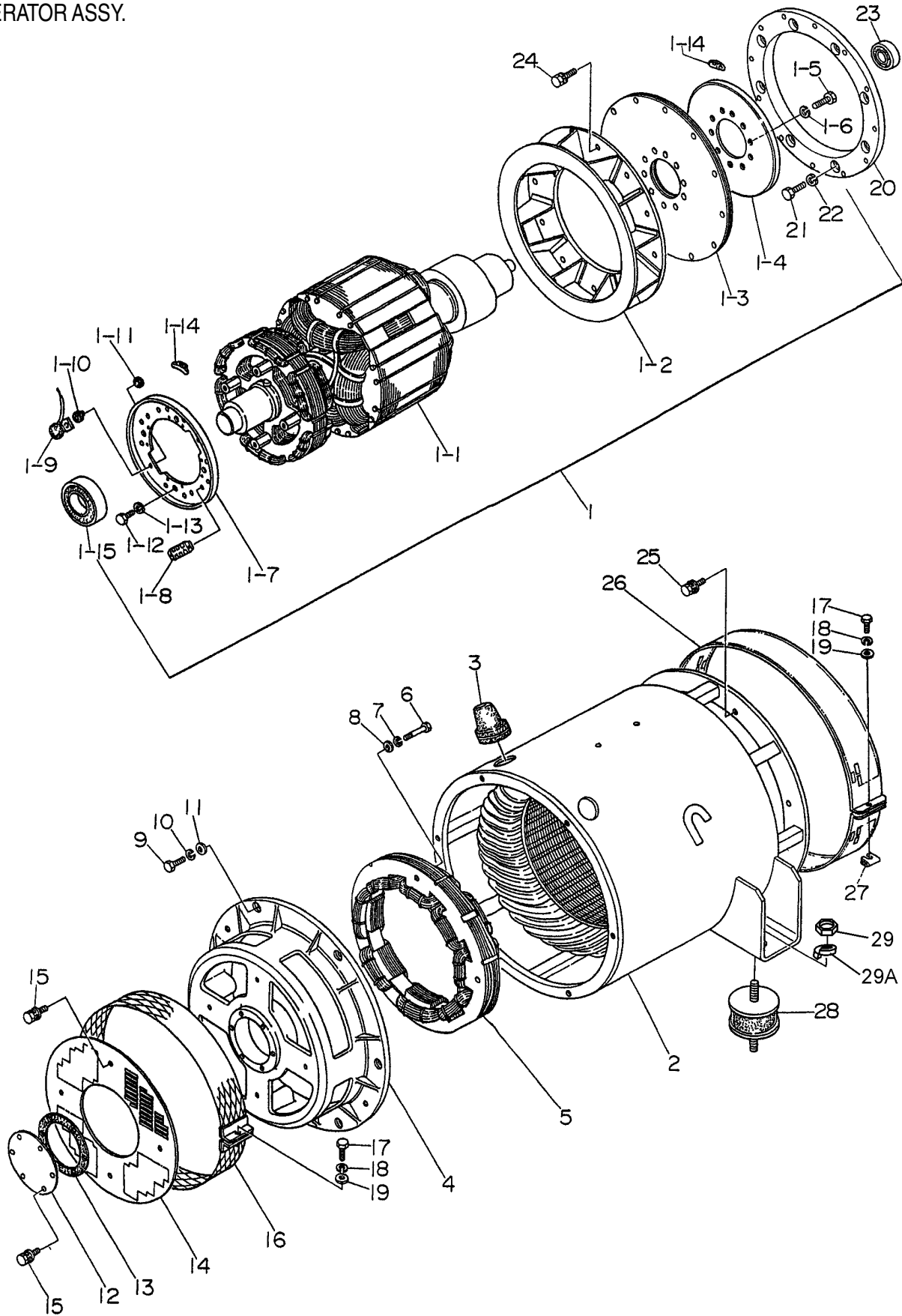

DCA-125USJ (50 HZ)— GENERATOR ASSY.

GENERATOR ASSY.

<u>NO.</u>	<u>PART NO.</u>	<u>PART NAME</u>	<u>QTY.</u>	<u>REMARKS</u>
1	C0110000002	ROTOR ASSY.	1	
1-1*		FIELD ASSY.	1	
1-2*	8131070013	FAN	1	
1-3*	8131611014	COUPLING DISK	8	
1-4*	8131015003	BALANCING PLATE	1	PURCHASE SET OF 1-14
1-5*	0012112035	HEX HEAD BOLT	10	
1-6*	0042612000	SPRING WASHER	10	
1-7*	8101026013	SET PLATE, RECTIFIER	1	PURCHASE SET OF 1-14
1-8*	0601821349	RECTIFIER	2	PT3610
1-9*	0601822601	SURGE ABSORBER	1	ERZ-M14JK621A
1-10*	8001020004	INSULATOR WASHER	1	
1-11*	8001020504	INSULATOR WASHER	1	
1-12*	0010110020	HEX, HEAD BOLT	4	
1-13*	0040010000	SPRING WASHER	4	
1-14*	0601000209	BALANCING WEIGHT KIT	1	
1-15*	0071906312	BEARING	1	6312DDUC3
2	C0130000503	STATOR ASSY.	1	
3	0845041804	GROMMET	2	
4	8131315202	END BRACKET	1	
5	8101350013	FIELD ASSY. EXCITER	1	
6	0012110060	HEX, HEAD BOLT	4	
7	0042610000	SPRING WASHER	4	
8	0041210000	PLAIN WASHER	4	
9	0010112035	HEX, HEAD BOLT	6	
10	0041212000	SPRING WASHER	6	
11	0041212000	PLAIN WASHER	6	
12	8131310104	COVER, BEARING	1	
13	8131312204	GASKET, BEARING	1	
14	8131331003	COVER, END BRACKET	1	
15	0017106012	HEX, HEAD BOLT	10	
16	8101333003	COVER, END BRACKET	1	
17	0010106030	HEX, HEAD BOLT	2	
18	0040006000	SPRING WASHER	2	
19	0041206000	PLAIN WASHER	2	
20	M3163400003	COUPLING RING	1	
21	0343204150	HEX, HEAD BOLT	8	
22	0043604000	SPRING WASHER	8	
23	0070506306	BEARING, 6306ZZ	1	
24	0012810030	HEX, HEAD BOLT	12	
25	0012810030	HEX, HEAD BOLT	12	
26	8131332014	COVER, FAN	1	
27	0600815000	NUT	1	
28	0605000063	RUBBER SUSPENSION, KA120SS	2	
29	0030016000	HEX, NUT	2	
29A	0040016000	SPRING WASHER	2	

DCA-125USJ (50 HZ)— CONTROL BOX ASSY.

CONTROL BOX ASSY.

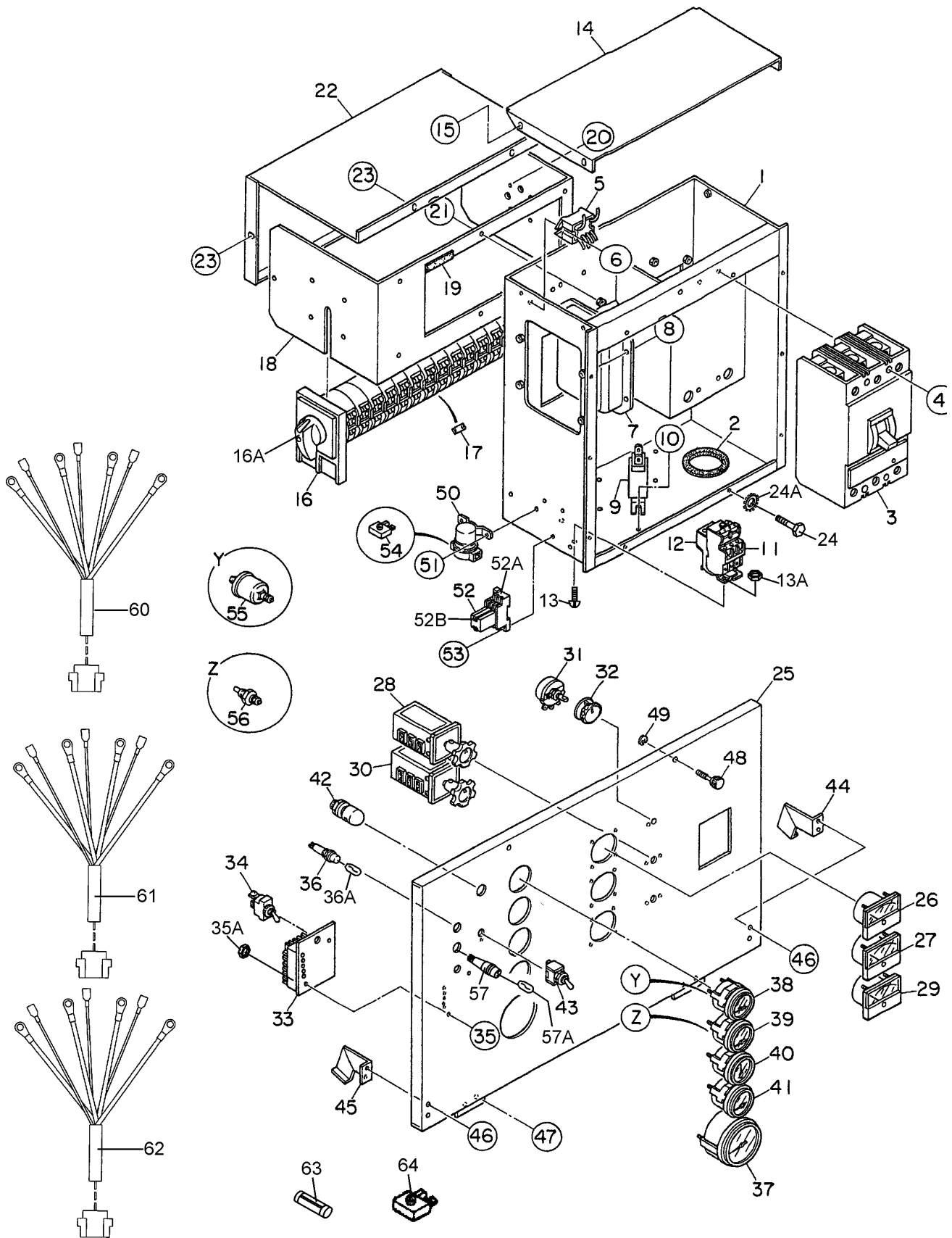

DCA-125USJ (50 HZ)— CONTROL BOX ASSY.

CONTROL BOX ASSY.

<u>NO.</u>	<u>PART NO.</u>	<u>PART NAME</u>	<u>QTY.</u>	<u>REMARKS</u>
1	M3213000702	CONTROL BOX	1	
2	0330000180	EDGING	2	
3	0601808823	CIRCUIT BREAKER, 300A	1	LAF3630010393P
4	0021006080	MACHINE SCREW	4	
5	0601823863	RELAY UNIT	2	MSA9013A
6	0027104016	MACHINE SCREW	4	
7	0601820671	AUTOMATIC VOLTAGE REGULATOR	1	NTA-5A-2DB
8	0027105016	MACHINE SCREW	4	
9	0601806118	CURRENT TRANSFORMER	3	814-943 200/5A
10	0027106016	MACHINE SCREW	6	
11	0601820845	OVER CURRENT RELAY	1	LR2D1308
12	0601820846	OVER CURRENT RELAY	1	LA7D1064
13	0027104016	MACHINE SCREW	2	
13A	0207004000	HEX, NUT	2	
14	M3213500013	CONTROL BOX COVER	1	
15	0016906016	HEX, HEAD BOLT	4	
16	M3270100104	SELECTOR SWITCH	1	XUSS01574
16A	047230402	KNOB, SELECTOR SWITCH	1	
17	M3276600004	SPACER	8	
18	M3213600503	SWITCH BRACKET	1	
19	03300003330	EDGING	2	
20	0027104010	MACHINE SCREW	4	
21	0016906016	HEX, HEAD BOLT	6	
22	M3213600604	SWITCH COVER	1	
23	0016906016	HEX, HEAD BOLT	4	
24	0016906016	HEX, HEAD BOLT	10	
24A	0040506000	TOOTHED WASHER	1	
25	M3223000503	CONTROL PANEL	1	
26	0601807641	FREQUENCY METER	1	FCF-6 45~65Hz 240V
27	0601808988	AC AMMETER	1	ACF-6 0~200A/400A:5A
28	0601801040	CHANGE-OVER SWITCH, AMMETER	1	SL-2AS
29	0601806859	AC VOLTMETER	1	SCF-6 0~600V
30	0601801041	CHANGE-OVER SWITCH, VOLTMETER	1	SL-2VS

DCA-125USJ (50 HZ)— CONTROL BOX ASSY.

CONTROL BOX ASSY.

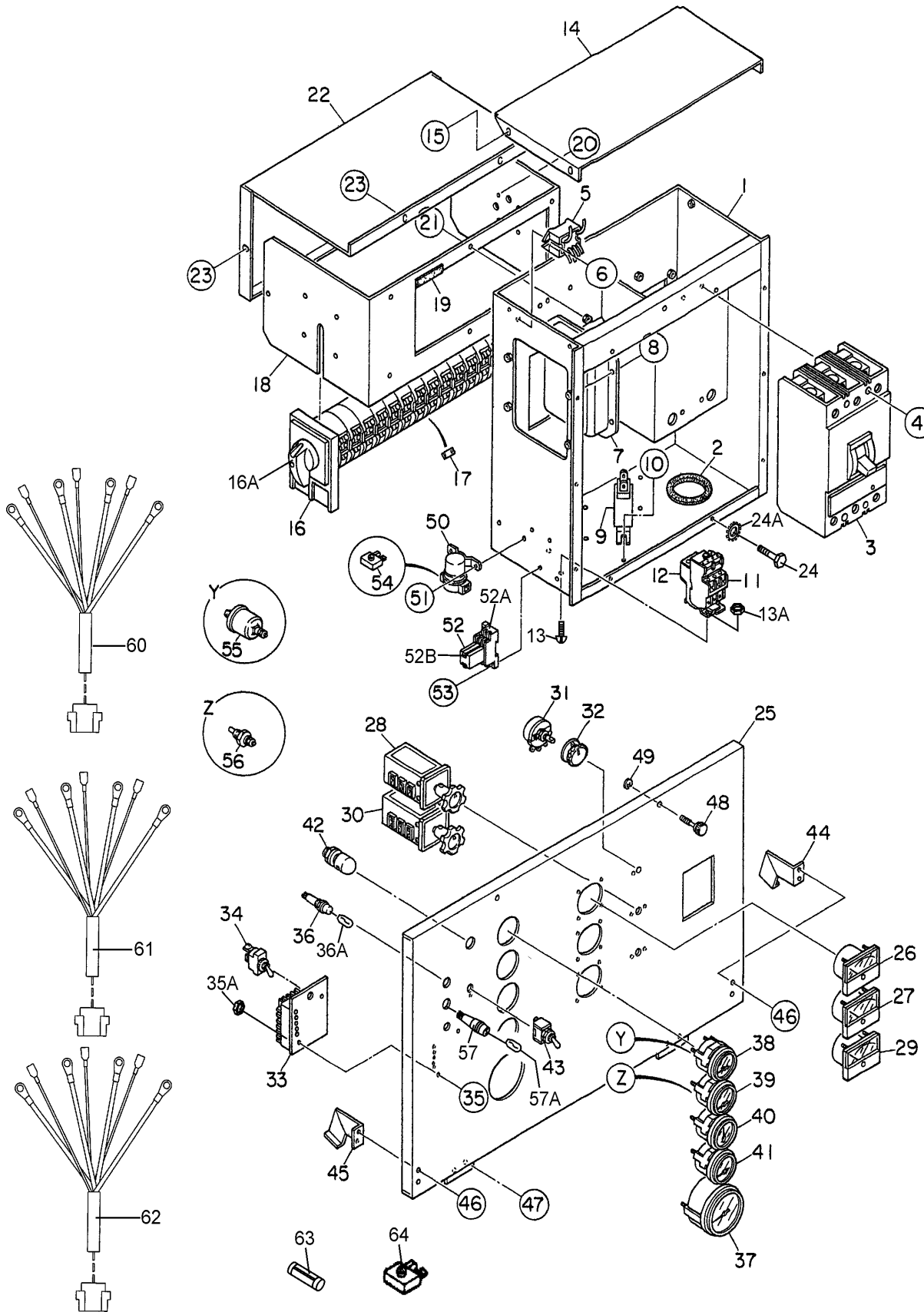

DCA-125USJ (50 HZ)— CONTROL BOX ASSY.

CONTROL BOX ASSY.

<u>NO.</u>	<u>PART NO.</u>	<u>PART NAME</u>	<u>QTY.</u>	<u>REMARKS</u>
31	0601840073	RHEOSTAT (VOLTAGE REGULATOR)	1	RA20A2SE102BJ 2W 1k OHM
32	0601840121	KNOB	1	
33	ECUCAN71	CONTROLLER, 50Hz	1	
34	0601831340	SWITCH	1	7562K4
35	0027104040	MACHINE SCREW	2	
35A	0207004000	HEX, NUT	2	
36	0602103092	PREHEAT LAMP	1	PL-05
36A	0601810245	BULB	1	
37	0602120096	TACHOMETER	1	111812
38	0602122093	OIL PRESSURE GAUGE	1	100174
39	0602123092	WATER TEMPERATURE GAUGE	1	100182
40	0602121080	CHARGING AMMETER	1	100158
41	0602125090	FUEL GAUGE	1	100176
42	0601810141	PANEL LIGHT	1	8826800370
43	0601831330	SWITCH, PANEL LIGHT	1	90-0001
44	M1223100004	STOPPER	1	
45	M3223100004	STOPPER	1	
46	0027105010	MACHINE SCREW	4	
47	0027105010	MACHINE SCREW	4	
48	M9220100004	SET SCREW	2	
49	0080200007	SNAP RING	2	
50	0602202592	STARTER RELAY	1	AT141011
51	0027106018	MACHINE SCREW	2	
52	LY2DDC12V	RELAY	1	
52A	PTF08A	BASE	1	
52B	PYCA1	CLIP	2	
53	0027104020	MACHINE SCREW	2	
54	0601823240	RECTIFIER	1	DE4503
55	0602122272	UNIT, OIL PRESSURE	1	108497
56	1518183040	SENDER, WATER SWITCH	1	REPLACES P/N 0602123282
57	0602103092	ALARM LAMP, PL095	1	8400041~
57A	0601810245	BULB	1	8400041~
60	M3246701904	WIRE HARNESS, GENERATOR	1	
61	M3357201102	WIRE HARNESS, ENGINE	1	
62	M3357200304	WIRE HARNESS, FUEL LEAK	1	8400041~
63	0601802149	FUSE	2	F-106510A
64	0601823240	RECTIFIER	1	DE4503

DCA-125USJ (50 HZ)— ENGINE AND RADIATOR ASSY.

ENGINE AND RADIATOR ASSY.

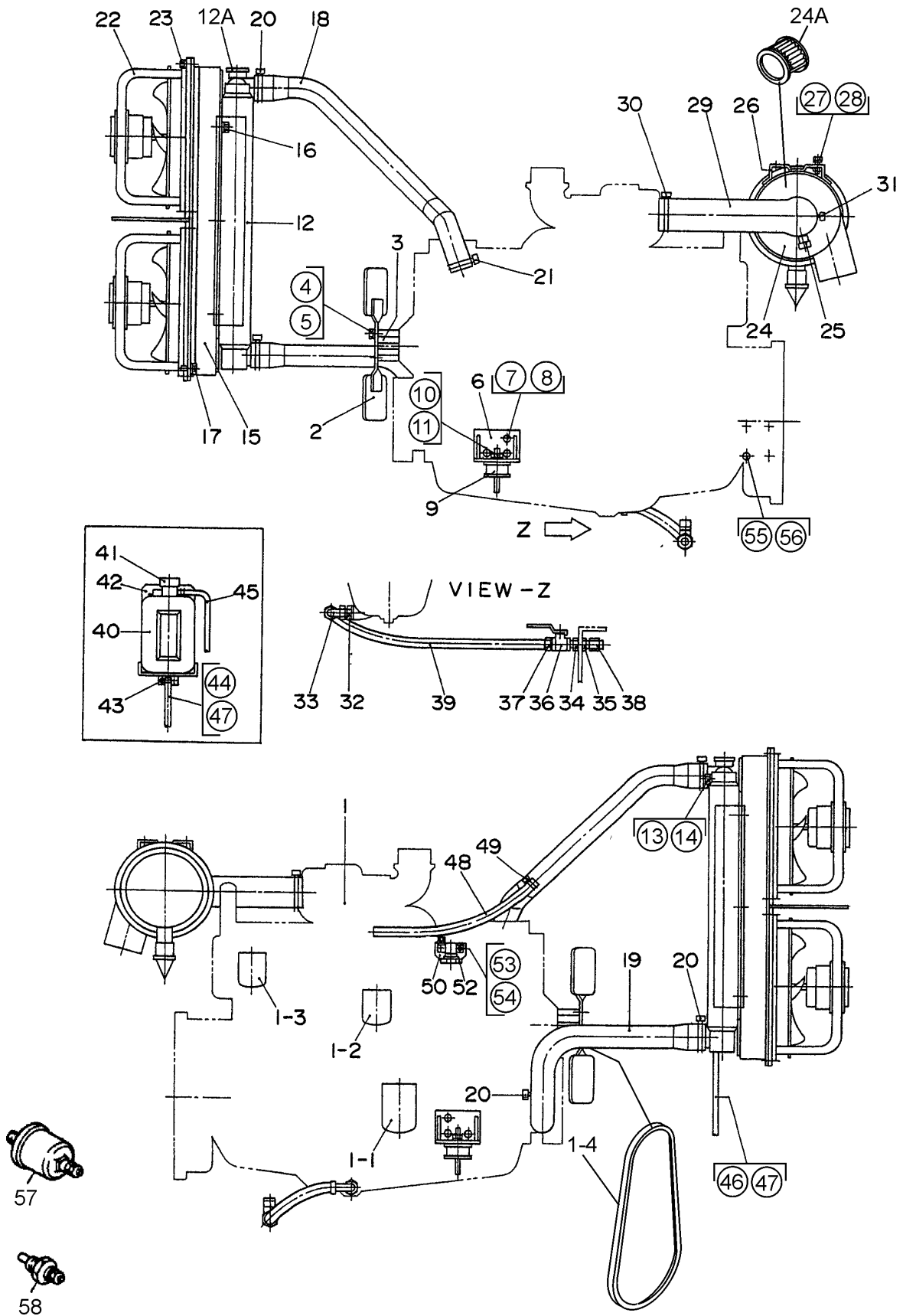

DCA-125USJ (50 HZ)— ENGINE AND RADIATOR ASSY.

ENGINE AND RADIATOR ASSY.

NO.	PART NO.	PART NAME	QTY.	REMARKS
1	M3923200054	ENGINE & RADIATOR SET	1	JOHN DEERE 6068TF275
1-1	0602041292	CARTRIDGE, OIL FILTER	1	RE504836
1-2	0602042594	CARTRIDGE, PRIMARY, FUEL FILTER	1	RE517181
1-3	0602042595	CARTRIDGE, FINAL, FUEL FILTER	1	RE509031
1-4	0602011493	FAN BELT	1	2402
2	0602060003	BLOWER FAN	1	AT39247
3	0602061000	FAN SPACER	1	R81911
4	0012110095	HEX, HEAD BOLT	4	
5	0042510000	SPRING WASHER	4	
6	M2303200303	ENGINE FOOT	2	
7	0010312030	HEX, HEAD BOLT	6	
8	0040012000	SPRING WASHER	6	
9	0605000060	RUBBER SUSPENSION	2	
10	0030012000	HEX, NUT	2	
11	0040012000	SPRING WASHER	2	
12	C0923200124	RADIATOR	1	
12A	0602011062	CAP, RADIATOR	1	
13	M9200100904	PLUG	1	
14	0150000016	O-RING	1	
15	M3131300103	FAN BRACKET	1	
16	0016910025	HEX, HEAD BOLT	6	
17	0016910025	HEX, HEAD BOLT	4	
18	M3310500813	RADIATOR HOSE	1	
19	M3310500903	RADIATOR HOSE	1	
20	0605515148	HOSE BAND	3	
21	0605515147	HOSE BAND	1	
22	0601822794	FAN MOTOR	2	
23	0017110035	HEX, HEAD BOLT	8	
24	0602046258	AIR CLEANER	1	FRG100297
24A	0602046377	ELEMENT, AIR CLEANER	1	P778214
25	0602040650	INDICATOR, AIR CLEANER	1	RBX00-2252
26	0602040596	BAND, AIR CLEANER	2	
27	0016908020	HEX, HEAD BOLT	4	
28	0207008000	HEX, NUT	4	
29	M3373100003	HOSE, AIR CLEANER	1	
30	0605515146	HOSE BAND	1	

DCA-125USJ (50 HZ)— ENGINE AND RADIATOR ASSY.

ENGINE & RADIATOR ASSY.

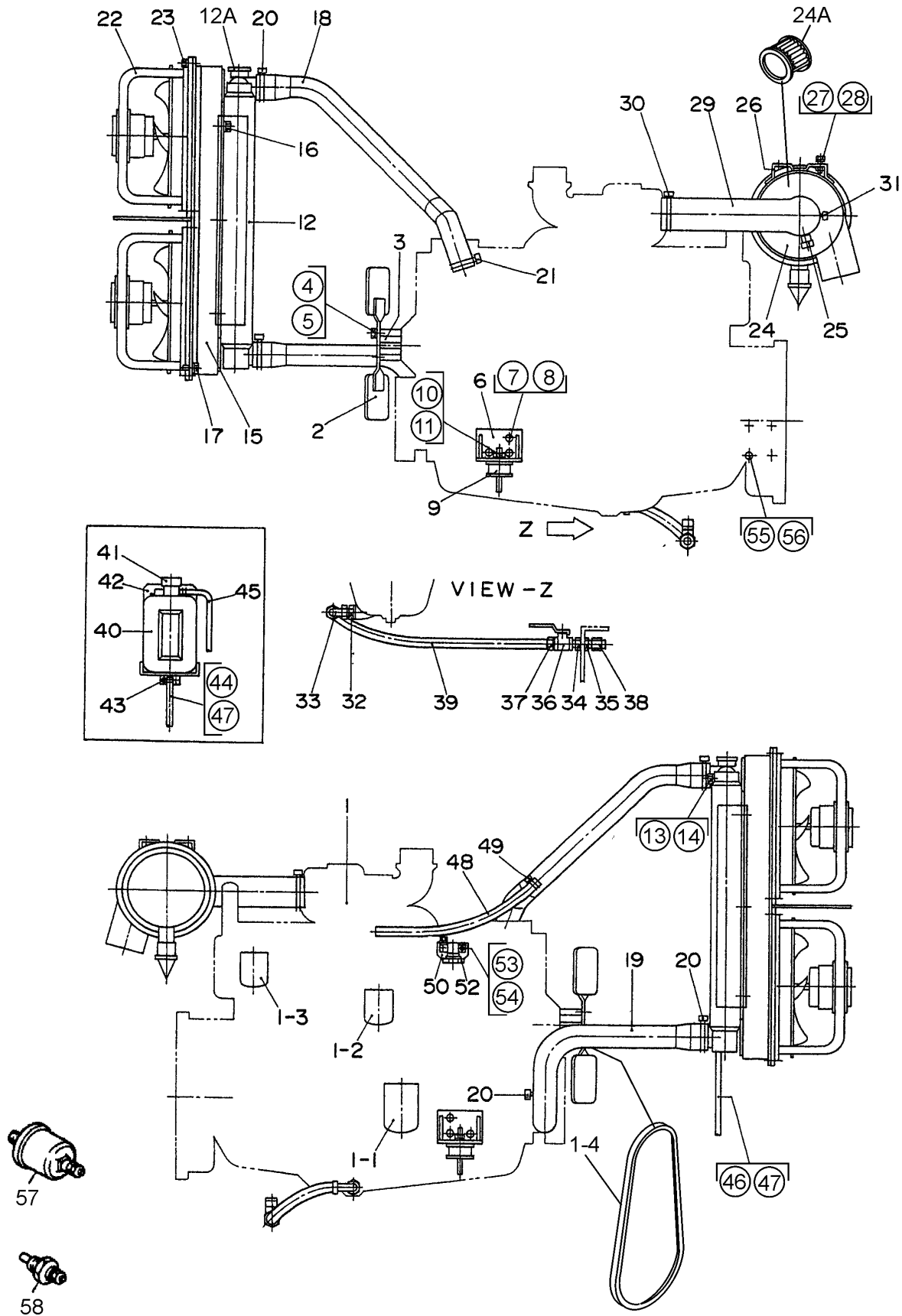

DCA-125USJ (50 HZ)— ENGINE AND RADIATOR ASSY.

ENGINE & RADIATOR ASSY.

<u>NO.</u>	<u>PART NO.</u>	<u>PART NAME</u>	<u>QTY.</u>	<u>REMARKS</u>
31	0605515197	HOSE BAND	1	
32	0602022563	ADAPTER	1	
33	0602022561	90 DEGREE ELBOW	1	
34	0603306590	CONNECTOR	1	
35	0603300285	ROCKNUT	1	
36	0605511395	VALVE	1	
37	0603306395	HOSE JOINT	1	
38	0602021070	CAP	1	
39	0269200450	DRAIN HOSE	1	
40	M9300000203	RESERVE TANK	1	
41	0602010900	CAP, RESERVE TANK	1	
42	M3316100303	BRACKET, RESERVE TANK	1	
43	0016908020	HEX, HEAD BOLT	3	
44	0199102200	HOSE	1	
45	0193600700	HOSE	1	
46	0193601000	HOSE	1	
47	0605515106	HOSE BAND	3	
48	M3326000204	BLOWBY HOSE	1	
49	0605515149	HOSE BAND	1	
50	M3260600104	RELAY BRACKET	1	
52	0602202592	RELAY	1	AT141011
53	0027106016	MACHINE SCREW	2	
54	0030006000	HEX, NUT	2	
55	0017112025	HEX, HEAD BOLT	1	
56	0040512000	TOOTHED WASHER	1	
57	0602123261	UNIT, WATER TEMPERATURE	1	
58	1718939010	SENDER, OIL SWITCH	1	REPLACES P/N 0602122281

DCA-125USJ (50 HZ)— OUTPUT TERMINAL ASSY.

OUTPUT TERMINAL ASSY.

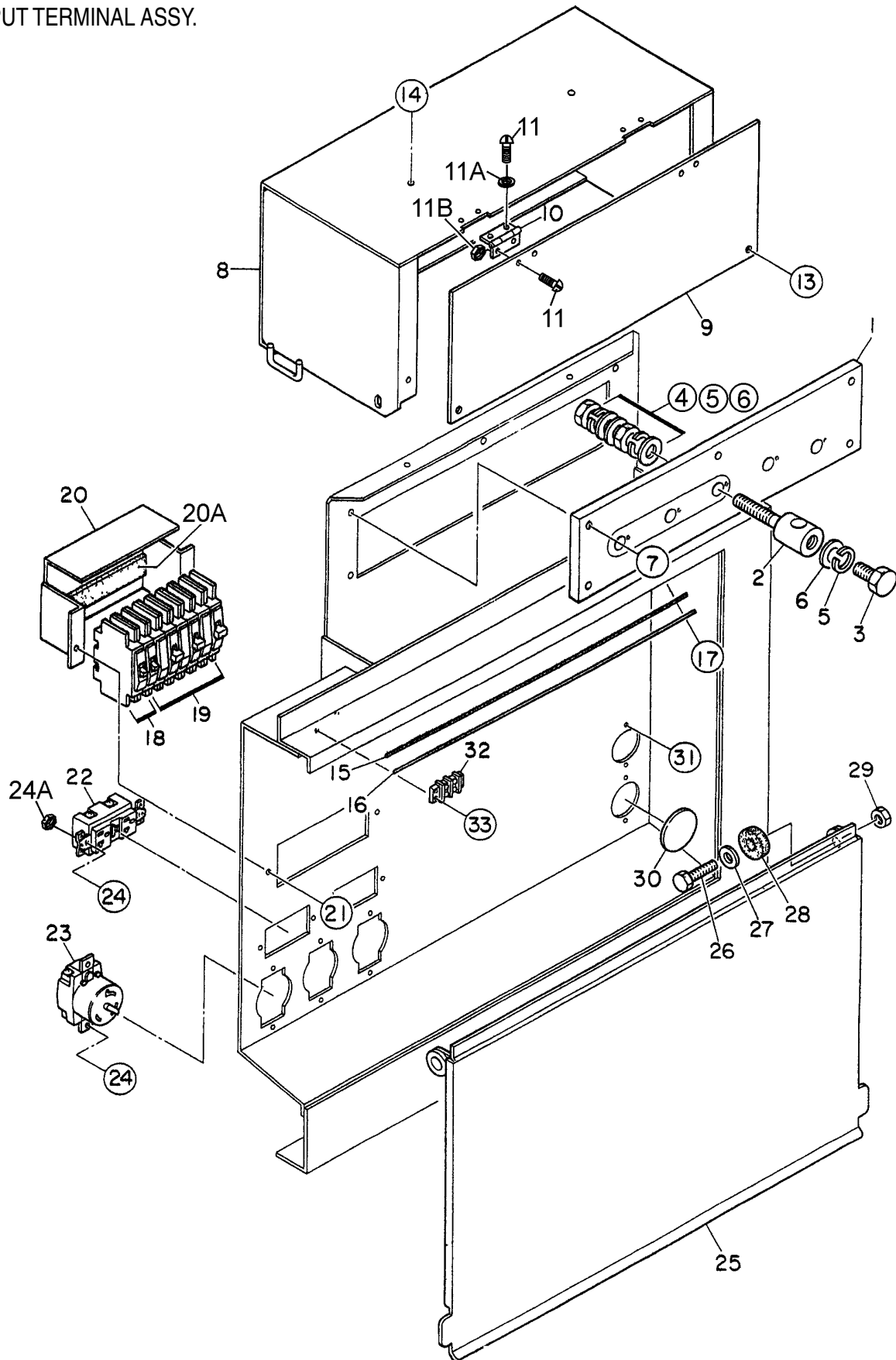

DCA-125USJ (50 HZ)— OUTPUT TERMINAL ASSY.

OUTPUT TERMINAL ASSY.

<u>NO.</u>	<u>PART NO.</u>	<u>PART NAME</u>	<u>QTY.</u>	<u>REMARKS</u>
1	M3230700003	TERMINAL PANEL	1	
2	M9220100304	OUTPUT TERMINAL BOLT	5	
3	M9220100404	TIE BOLT	5	
4	0039316000	HEX, NUT	10	
5	0040016000	SPRING WASHER	15	
6	0041416000	PLAIN WASHER	20	
7	0016908035	HEX, HEAD BOLT	5	
8	M3236100503	TERMINAL COVER	1	
9	M3236100404	OUTPUT WINDOW	1	
10	0605010040	HINGE	2	
11	0027103010	MACHINE SCREW	4	
11A	0030003000	HEX, NUT	4	
11B	0041203000	PLAIN WASHER	4	
12	0027103010	MACHINE SCREW	4	
12A	0030003000	HEX, NUT	4	
13	0016906020	HEX, HEAD BOLT	2	
14	0016906016	HEX, HEAD BOLT	4	
15	M3236400004	CABLE OUTLET COVER	1	
16	M3236300004	SUPPORTER, CABLE OUTLET COVER	1	
17	0016906020	HEX, HEAD BOLT	6	
18	0601808803	CIRCUIT BREAKER, 1-POLE 20A	2 QOU 120B
19	0601808804	CIRCUIT BREAKER, 2-POLE 50A	3 QOU 250B
20	M1260700304	BREAKER FITTING COVER	1	
20A	022100150	CUSHION RUBBER	1	
21	0016906020	HEX, HEAD BOLT	2	
22	0601812598	RECEPTACLE	2 GF530EM 125V 20A X 2
23	0601812538	RECEPTACLE	3 CS6369 250V 50A
24	0027104016	MACHINE SCREW	10	
24A	0207004000	HEX, NUT	10	
25	M3236100213	TERMINAL COVER	1	
26	0010112045	HEX, HEAD BOLT	2	
27	0041212000	PLAIN WASHER	2	
28	M9310200004	STAY RUBBER	2	
29	0030012000	HEX, NUT	2	
30	0603306775	BLIND PLUG	2	
31	0027104016	MACHINE SCREW	4	
32	0601815194	TERMINAL	1	
33	0027104016	MACHINE SCREW	2	

ADD THE FOLLOWING DIGITS AFTER THE PART NUMBER WHEN ORDERING ANY PAINTED PANEL TO INDICATE COLOR OF UNIT:

1-ORANGE	5-BLACK
2-WHITE	6-CATERPILLAR YELLOW
3-SPECTRUM GREY	7-CATO GOLD
4-SUNBELT GREEN	8-RED

THE SERIAL NUMBER MAY BE REQUIRED.

DCA-125USJ (50 HZ)— BATTERY ASSY.

BATTERY ASSY.

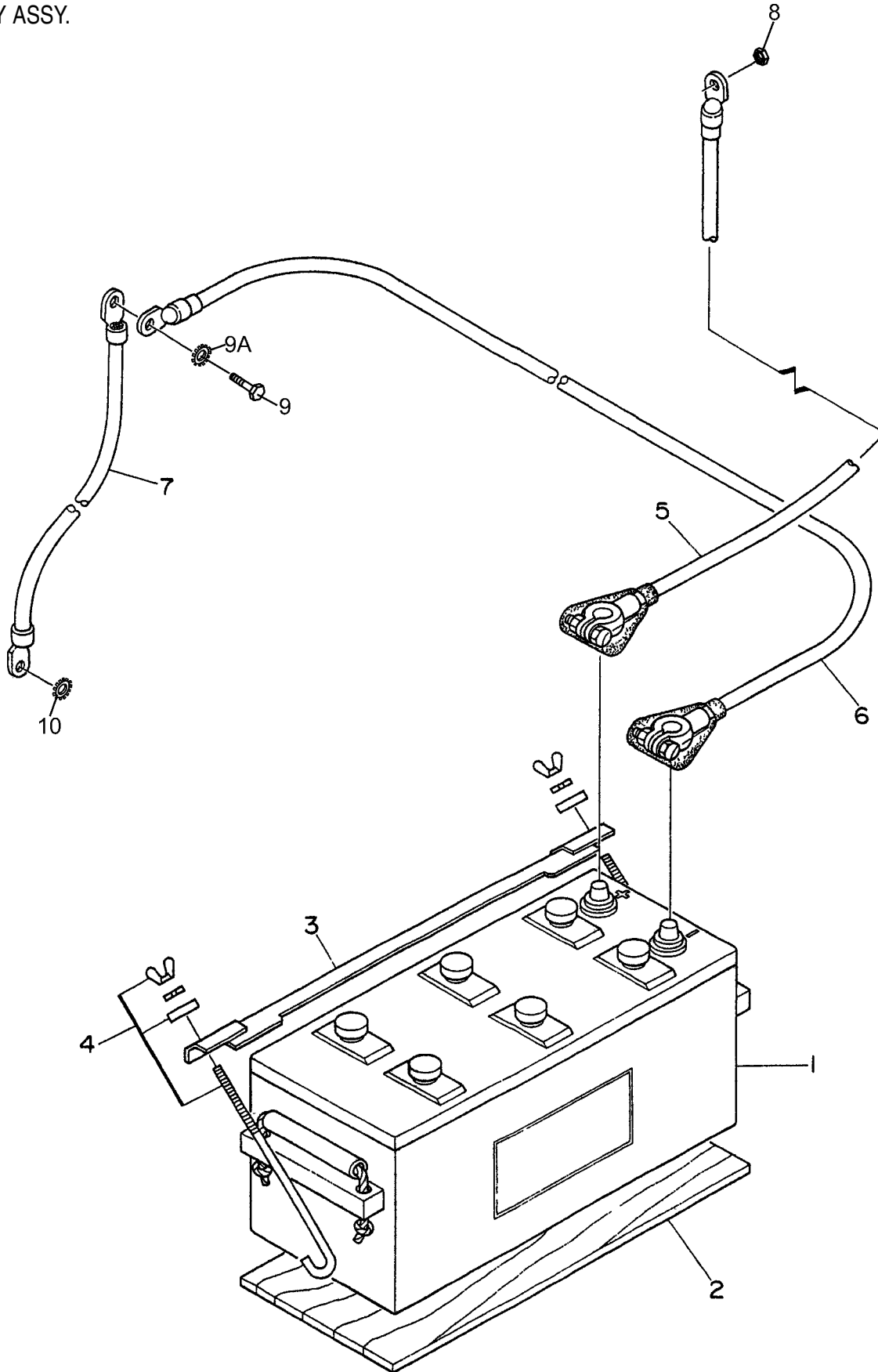

DCA-125USJ (50 HZ)— BATTERY ASSY.

BATTERY ASSY.

<u>NO.</u>	<u>PART NO.</u>	<u>PART NAME</u>	<u>QTY.</u>	<u>REMARKS</u>
1	0602220196	BATTERY	1	4D-2
2	M9310500404	BATTERY SHEET	1	
3	M9103000504	BATTERY BAND	1	
4	0602220921	BATTERY BOLT SET	2	
5	M3346900904	BATTERY CABLE	1	
6	M3346901004	BATTERY CABLE	1	
7		CABLE	1	MAKE LOCALLY
8	0030012000	HEX, NUT	1	
8A	0040012000	SPRING WASHER	1	
9	0017112025	HEX, HEAD BOLT	1	
9A	0040512000	TOOTHED WASHER	1	
10	0040520000	TOOTHED WASHER	1	

DCA-125USJ (50 HZ)— MUFFLER ASSY.

MUFFLER ASSY.

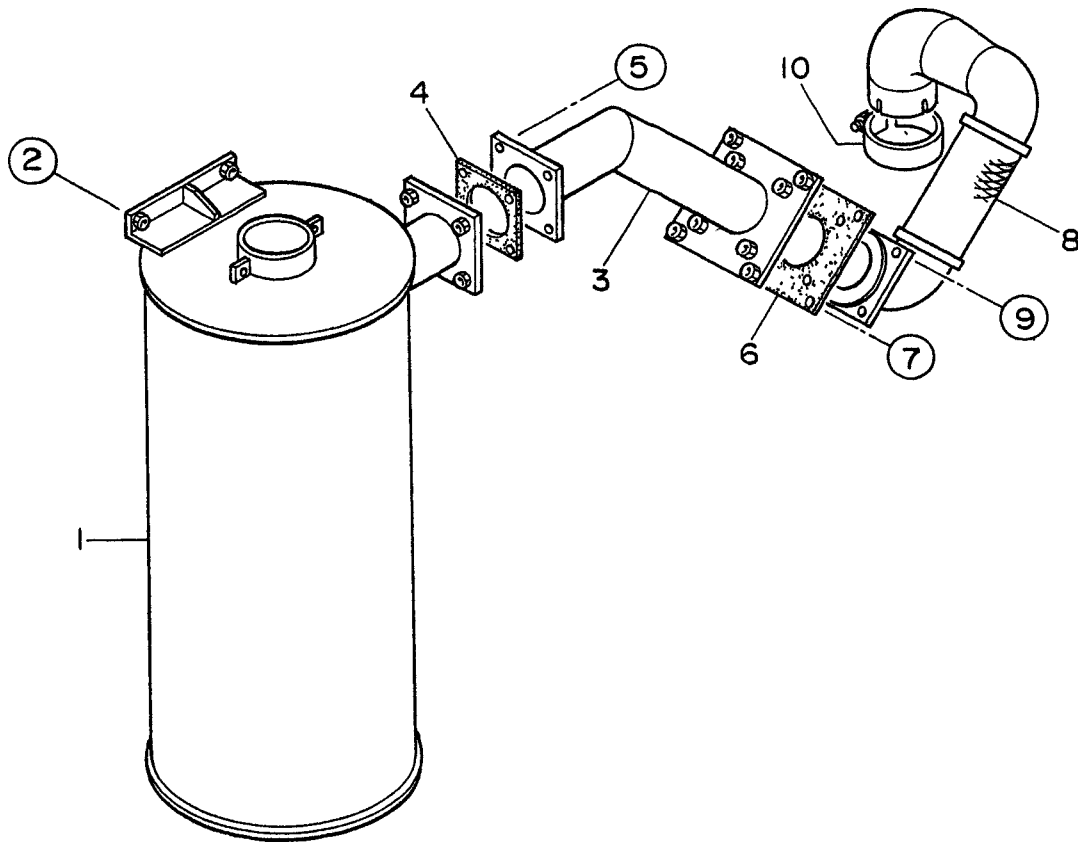

DCA-125USJ (50 HZ)— MUFFLER ASSY.

MUFFLER ASSY.

<u>NO.</u>	<u>PART NO.</u>	<u>PART NAME</u>	<u>QTY.</u>	<u>REMARKS</u>
1	M3330100402	MUFFLER	1	
2	0017112030	HEX, HEAD BOLT	4	
3	M3333000903	EXHAUST PIPE	1	
4	M3333200304	GASKET	1	
5	0017110040	HEX, HEAD BOLT	4	
6	M3333200204	GASKET	1	
7	0017108040	HEX, HEAD BOLT	4	
7	0017110035	HEX, HEAD BOLT	4	S/N 8500015~
8	M3333000803	EXHAUST PIPE	1	
9	0016908055	HEX, HEAD BOLT	4	
9	0017110050	HEX, HEAD BOLT	4	S/N 8500015~
10	0602325066	CLAMP	1	

DCA-125USJ (50 HZ)— FUEL TANK ASSY.

FUEL TANK ASSY.

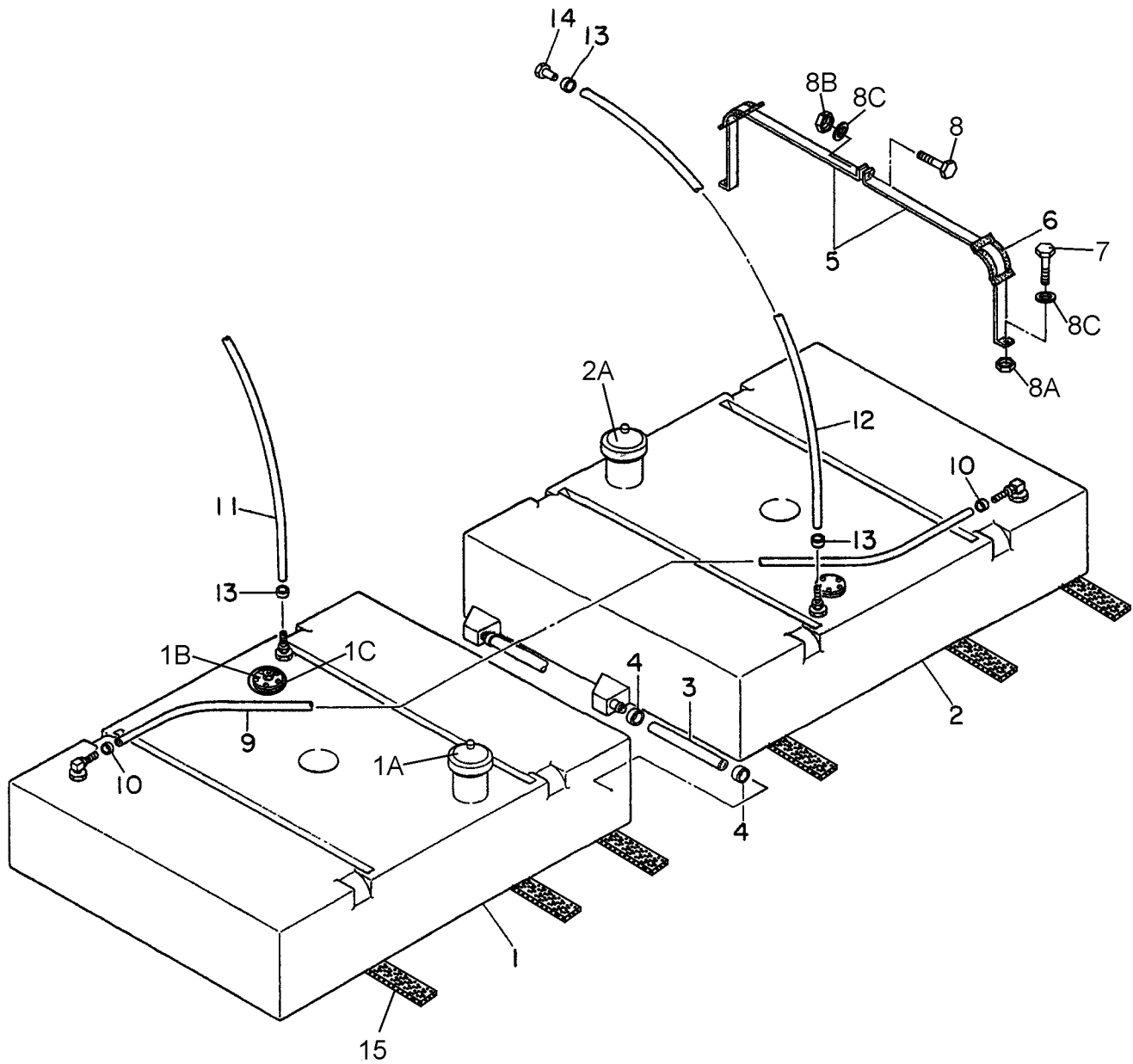

DCA-125USJ (50 HZ)— FUEL TANK ASSY.

FUEL TANK ASSY.

<u>NO.</u>	<u>PART NO.</u>	<u>PART NAME</u>	<u>QTY.</u>	<u>REMARKS</u>
1	M3363001402	FUEL TANK	1	
1A	0605505070	FUEL TANK CAP	1	
1B	0605501074	FUEL SENDER UNIT	1	
1C	0605516090	GASKET	1	
2	M3363001504	FUEL TANK	1	
2A	0605505070	FUEL TANK CAP	1	
3	0191700260	CONNECT HOSE	2	
4	0605515149	HOSE BAND	4	
5	M3363200404	TANK BAND	8	
6	M9310500104	SUPPORTER SHEET	8	
7	0016908020	HEX, HEAD BOLT	8	
8	0016908055	HEX, HEAD BOLT	4	
8A	0030008000	HEX, NUT	8	
8B	0207308000	HEX, NUT	4	
8C	0041208000	PLAIN WASHER	12	
9	0191302500	VENT HOSE	1	
10	0605515109	HOSE BAND	2	
11	0191301200	SUCTION HOSE	1	
12	0191301200	RETURN HOSE	1	
13	0605515109	HOSE BAND	4	
14	0602042601	RETURN PIPE	1	RE67050
15	0222101000	TANK SHEET	6	

DCA-125USJ (50 HZ)— ENCLOSURE #1 ASSY.

ENCLOSURE #1 ASSY.

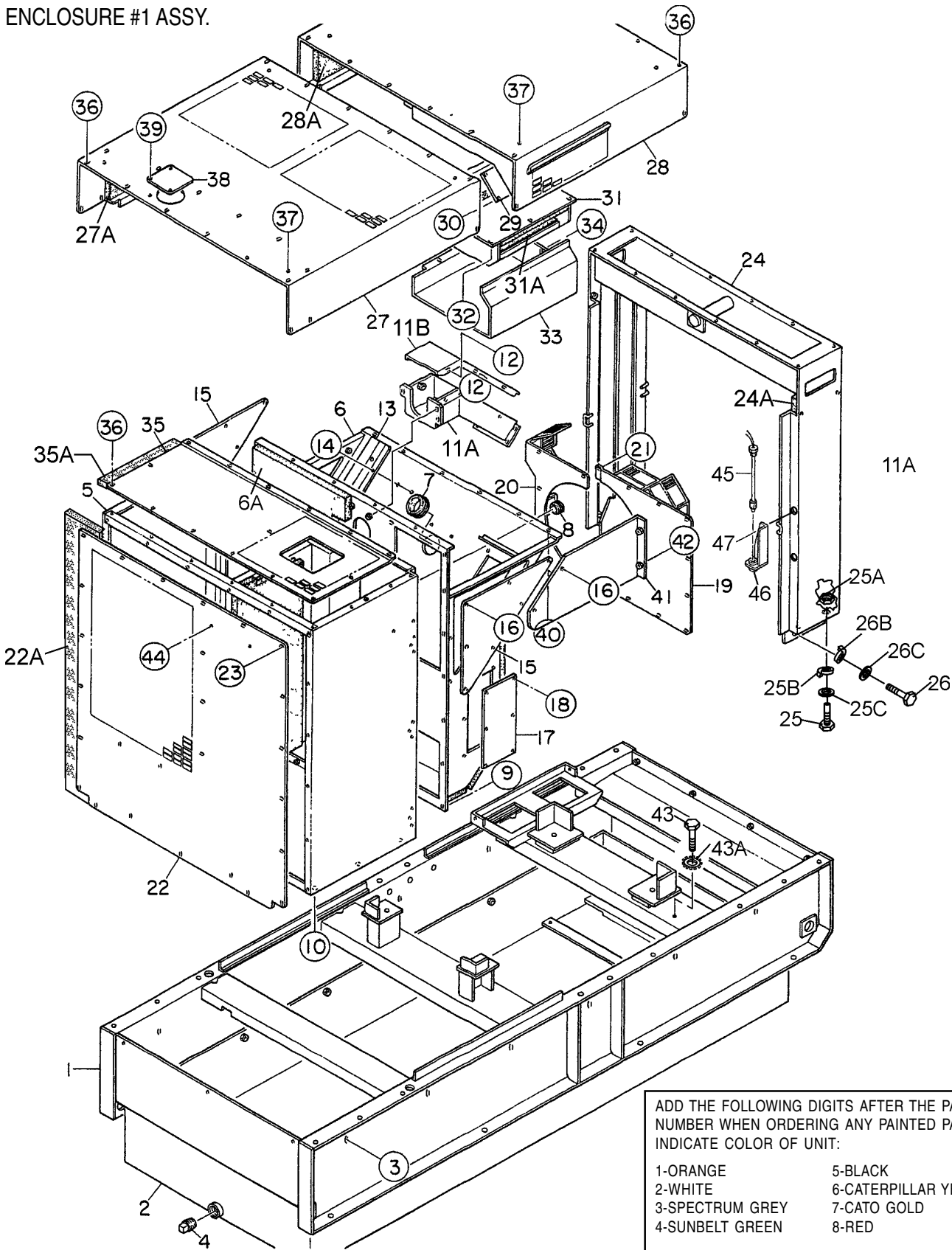

ADD THE FOLLOWING DIGITS AFTER THE PART NUMBER WHEN ORDERING ANY PAINTED PANEL TO INDICATE COLOR OF UNIT:

- | | |
|-----------------|----------------------|
| 1-ORANGE | 5-BLACK |
| 2-WHITE | 6-CATERPILLAR YELLOW |
| 3-SPECTRUM GREY | 7-CATO GOLD |
| 4-SUNBELT GREEN | 8-RED |

THE SERIAL NUMBER MAY BE REQUIRED.

DCA-125USJ (50 HZ)— ENCLOSURE #1 ASSY.

ENCLOSURE #1 ASSY.

<u>NO.</u>	<u>PART NO.</u>	<u>PART NAME</u>	<u>QTY.</u>	<u>REMARKS</u>
1	M3413001812	BASE	1	
2	M3363300303	ENVIRONMENTAL TANK	1	
3	0016910030	HEX, HEAD BOLT	12	
4	0603306797	PLUG	1	
5	M3423001202	FRONT FRAME	1	S/N 8500001 TO 8500040
5	M3423001602	FRONT FRAME	1	S/N 8500041~
5A	M3493107813	ACOUSTIC SHEET	1	S/N 8500001 TO 8500035
5A	M3493107823	ACOUSTIC SHEET	1	S/N 8500036 TO 8400040
5A	M3493111303	ACOUSTIC SHEET	1	S/N 8500041~
6	M3423001302	FRONT FRAME	1	S/N 8500001 TO 8500040
6	M3423001702	FRONT FRAME	1	S/N 8500041~
6A	M3493107813	ACOUSTIC SHEET	1	S/N 8500001 TO 8500035
6A	M3493107823	ACOUSTIC SHEET	1	S/N 8500036 TO 8500040
6A	M3493111303	ACOUSTIC SHEET	1	S/N 8500041~
7	0601851739	GROMMET	1	S/N 8500036 TO 8500040
8	0601850100	GROMMET	1	
9	0016908020	HEX, HEAD BOLT	26	
10	0016910025	HEX, HEAD BOLT	6	
11	M3131400203	HOSE COVER	1	S/N 8500001 TO 8500040
11A	M3131400103	HOSE COVER	1	S/N 8500041~
11B	M3131400004	HOSE COVER	1	S/N 8500041~
12	0016908020	HEX, HEAD BOLT	4	S/N 8500001 TO 8500040
12	0016906020	HEX, HEAD BOLT	13	S/N 8500041~
13	M3423500104	BRACKET	1	
14	0016906016	HEX, HEAD BOLT	6	
15	M3423200704	DUCT COVER	2	
16	0016906020	HEX, HEAD BOLT	14	
17	M3423200804	DUCT COVER	1	
18	0016906016	HEX, HEAD BOLT	6	
19	M3310300104	FAN SHROUD	1	
20	M3310300004	FAN SHROUD	1	
21	0016906020	HEX, HEAD BOLT	14	
22	M3423201003	COVER, FRONT FRAME	1	S/N 8500001 TO 8500035
22	M3423201203	COVER, FRONT FRAME	1	S/N 8500036~
22A	M3493107904	ACOUSTIC SHEET	1	
23	0016908020	HEX, HEAD BOLT	26	S/N 8500001 TO 8500040
23	0019208020	HEX, HEAD BOLT	26	S/N 8500041~
24	M3433000803	CENTER FRAME	1	S/N 8500001 TO 8500035
24	M3433000813	CENTER FRAME	1	S/N 8500036~

DCA-125USJ (50 HZ)— ENCLOSURE #1 ASSY.

ENCLOSURE #1 ASSY.

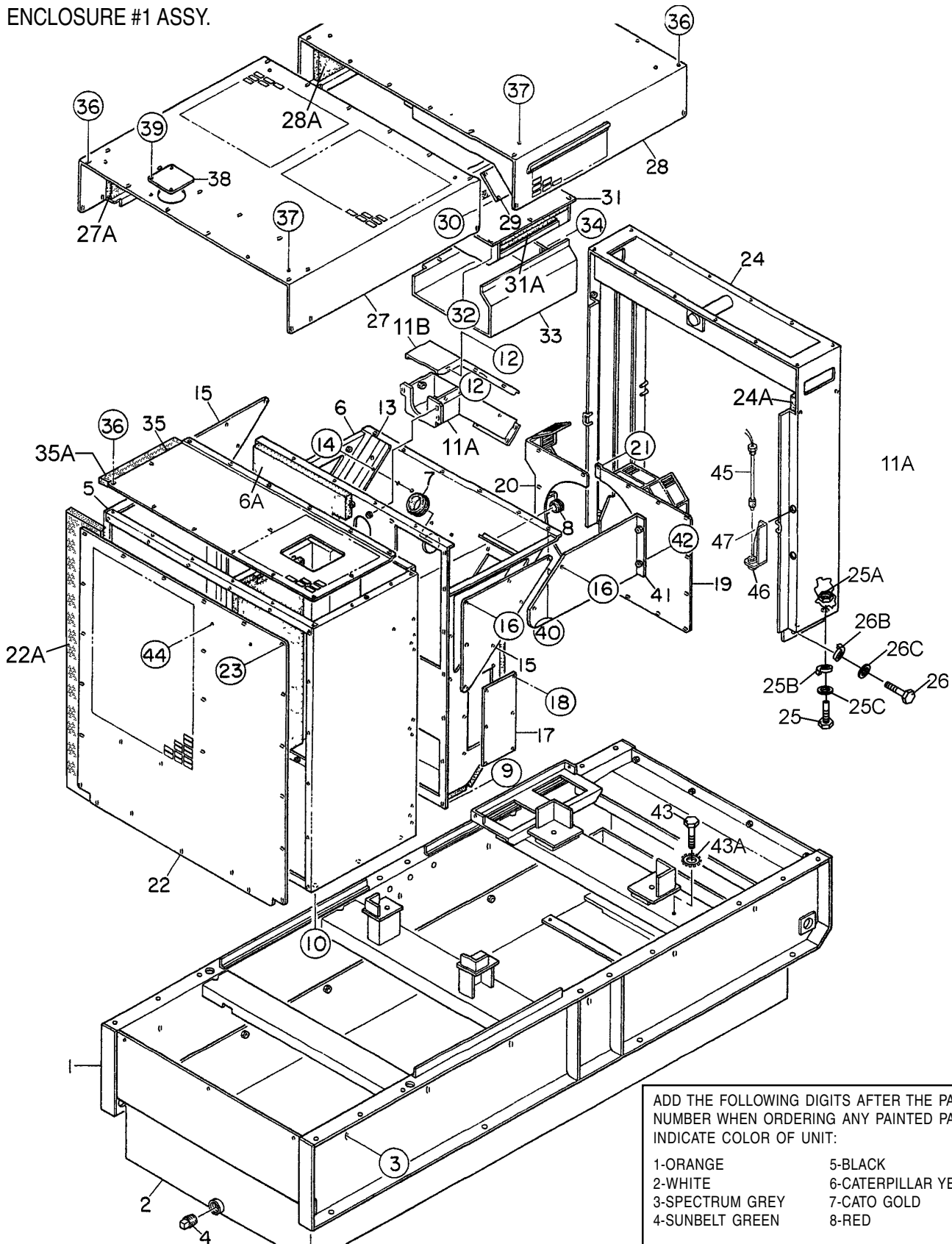

ADD THE FOLLOWING DIGITS AFTER THE PART NUMBER WHEN ORDERING ANY PAINTED PANEL TO INDICATE COLOR OF UNIT:

- | | |
|-----------------|----------------------|
| 1-ORANGE | 5-BLACK |
| 2-WHITE | 6-CATERPILLAR YELLOW |
| 3-SPECTRUM GREY | 7-CATO GOLD |
| 4-SUNBELT GREEN | 8-RED |

THE SERIAL NUMBER MAY BE REQUIRED.

DCA-125USJ (50 HZ)— ENCLOSURE #1 ASSY.

ENCLOSURE #1 ASSY.

<u>NO.</u>	<u>PART NO.</u>	<u>PART NAME</u>	<u>QTY.</u>	<u>REMARKS</u>
24A	M3493200614	ACOUSTIC SHEET	1	S/N 8500001 TO 8500040
24A	M3493201204	ACOUSTIC SHEET	1	S/N 8500041~
25	0010114040	HEX, HEAD BOLT	4	
25A	0030014000	HEX, NUT	4	
25B	0040014000	SPRING WASHER	4	
25C	0041214000	PLAIN WASHER	8	
26	0010120050	HEX, HEAD BOLT	4	
26A	0030020000	HEX, NUT	4	
26B	0040020000	SPRING WASHER	4	
26C	0041220000	PLAIN WASHER	8	
27	M3463100802	ROOF PANEL	1	
27A	M3493503914	ACOUSTIC SHEET	1	
28	M3463200502	ROOF PANEL	1	
28A	M3493504003	ACOUSTIC SHEET	1	
29	M3463200704	BACK PLATE	1	
30	0016906016	HEX, HEAD BOLT	6	
31	M3463200803	DUCT	1	
31A	M3493504104	ACOUSTIC SHEET	1	
32	0016908020	HEX, HEAD BOLT	8	
33	M3463400003	DUCT COVER	1	
34	0016908020	HEX, HEAD BOLT	6	
35	M3423200604	OVER COVER, FRONT FRAME	1	
35A	M3493108004	ACOUSTIC SHEET	1	
36	0016908020	HEX, HEAD BOLT	49	S/N 8500001 TO 8500040
36	0019208020	HEX, HEAD BOLT	49	S/N 8500041~
37	0016910025	HEX, HEAD BOLT	8	S/N 8500001 TO 8500040
37	0019210025	HEX, HEAD BOLT	8	S/N 8500041~
38	M3310600004	COVER, RADIATOR CAP	1	
39	0016908020	HEX, HEAD BOLT	4	
40	0016908020	HEX, HEAD BOLT	6	
41	M3483100004	COVER, EXHAUST PIPE	1	
42	0016908020	HEX, HEAD BOLT	2	S/N 8500001 TO 8500040
43	0016908020	HEX, HEAD BOLT	1	S/N 8500041~
43A	0040508000	TOOTHED WASHER	1	
44	0016906016	HEX, HEAD BOLT	2	S/N 8500001 TO 8500035
45	0605503062	FUEL LEAK DETECTION SWITCH	1	S/N 840003~
46	M1414800104	BRACKET	1	S/N 840003~
47	0017108020	HEX HEAD BOLT	2	S/N 840003~

DCA-125USJ (50 HZ)— ENCLOSURE #2 ASSY.

ENCLOSURE #2 ASSY.

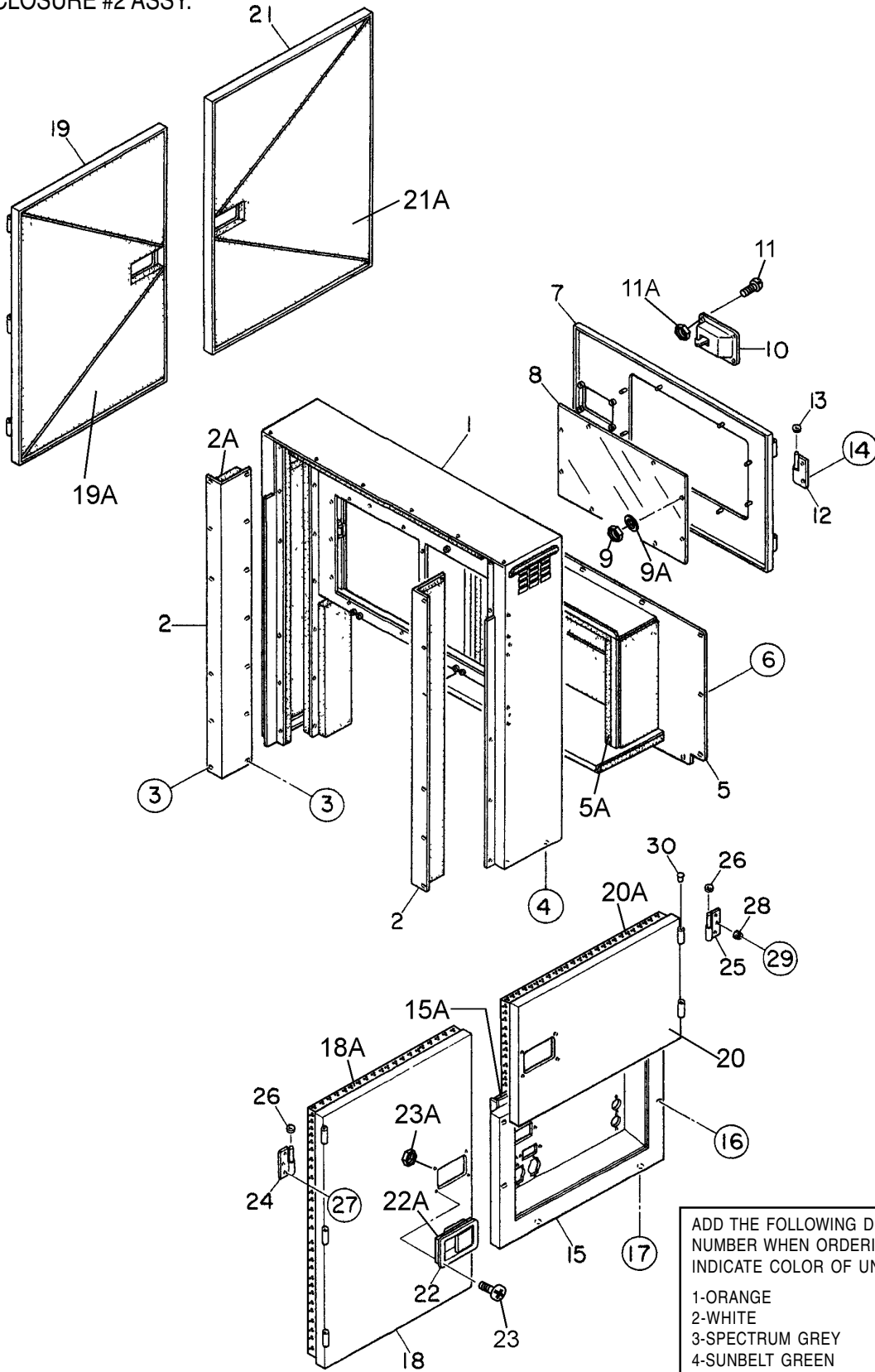

ADD THE FOLLOWING DIGITS AFTER THE PART NUMBER WHEN ORDERING ANY PAINTED PANEL TO INDICATE COLOR OF UNIT:

- | | |
|-----------------|----------------------|
| 1-ORANGE | 5-BLACK |
| 2-WHITE | 6-CATERPILLAR YELLOW |
| 3-SPECTRUM GREY | 7-CATO GOLD |
| 4-SUNBELT GREEN | 8-RED |

THE SERIAL NUMBER MAY BE REQUIRED.

DCA-125USJ (50 HZ)— ENCLOSURE #2 ASSY.

ENCLOSURE #2 ASSY.

<u>NO.</u>	<u>PART NO.</u>	<u>PART NAME</u>	<u>QTY.</u>	<u>REMARKS</u>
1	M3443000802	REAR FRAME	1	S/N 8500001 TO 8500035
1	M3443000812	REAR FRAME	1	S/N 8500036~
1A	M3493303203	ACOUSTIC SHEET	1	
2	M3443000904	DUCT	2	S/N 8500001 TO 8500035
2	M3443000914	DUCT	2	S/N 8500036~
2A	M3493303304	ACOUSTIC SHEET	2	
3	0016908020	HEX, HEAD BOLT	26	
4	0016910025	HEX, HEAD BOLT	4	
5	M3443301003	COVER, REAR FRAME	1	
5A	M3493303404	ACOUSTIC SHEET	1	
6	0016908020	HEX, HEAD BOLT	13	
7	M3443200503	DOOR, REAR FRAME	1	
8	M3443600304	WINDOW PLATE	1	
9	0207306000	HEX, NUT	8	
9A	0041206000	PLAIN WASHER	8	
10	M9113000002	DOOR HANDLE ASSY.	1	
11	0021806016	MACHINE SCREW	4	
11A	0030006000	HEX, NUT	4	
12	M9110100204	HINGE	2	
13	M9116100004	WASHER	2	
14	0016908020	HEX, HEAD BOLT	3	
15	M3453200802	SPLASHER PANEL	1	S/N 8500001 TO 8500035
15	M3453200812	SPLASHER PANEL	1	S/N 8500036~
15A	M3493417004	ACOUSTIC SHEET	1	S/N 8500001 TO 8500035
15A	M3493417014	ACOUSTIC SHEET	1	S/N 8500036~
16	0016908065	HEX, HEAD BOLT	4	S/N 8500001 TO 8500040
17	0016910025	HEX, HEAD BOLT	2	S/N 8500041~
18	M3453002503	SIDE DOOR	1	
18A	M3493416804	ACOUSTIC SHEET	1	
19	M3453002603	SIDE DOOR	1	
19A	M3493416904	ACOUSTIC SHEET	1	
20	M3453002703	SIDE DOOR	1	
20A	M3493417204	ACOUSTIC SHEET	1	
21	M3453002803	SIDE DOOR	1	
21A	M3493417104	ACOUSTIC SHEET	1	
22	M9113000002	DOOR HANDLE ASSY.	4	
22A	C9312500004	SEAL RUBBER	4	
23	0021806016	MACHINE SCREW	16	
23A	0030006000	HEX, NUT	16	
24	M9110100804	HINGE	6	
25	M9110100904	HINGE	5	
26	M9116100004	WASHER	11	
27	0016908020	HEX, HEAD BOLT	26	S/N 8500001 TO 8500040
27	0019208020	HEX, HEAD BOLT	26	S/N 8500041~
28	0601850097	STOPPER	8	
29	0027208025	MACHINE SCREW	8	
30	M9310000004	CAP	13	

DCA-125USJ (50 HZ)— RUBBER SEALS ASSY.

RUBBER SEALS ASSY.

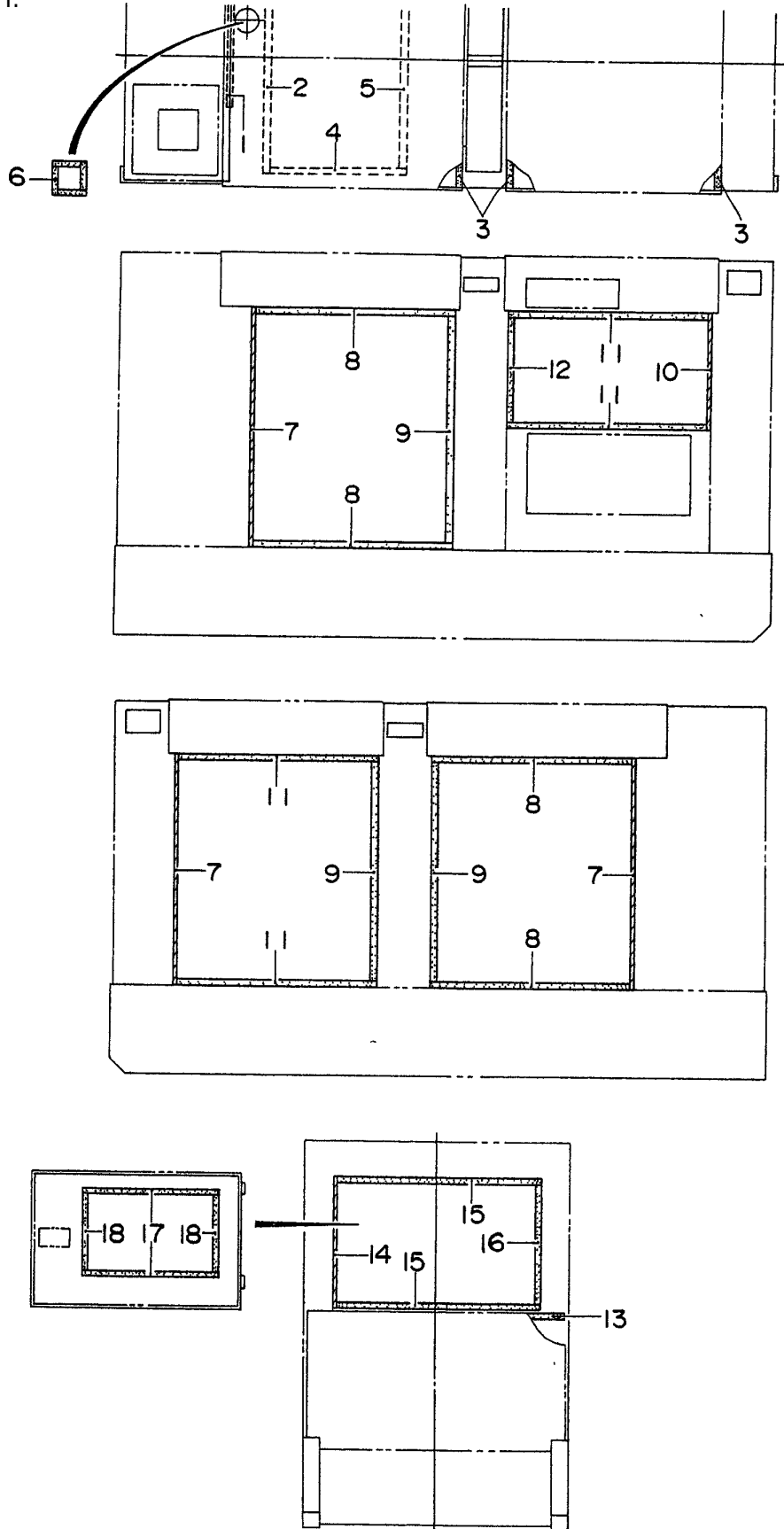

DCA-125USJ (50 HZ)— RUBBER SEALS ASSY.

RUBBER SEALS ASSY.

<u>NO.</u>	<u>PART NO.</u>	<u>PART NAME</u>	<u>QTY.</u>	<u>REMARKS</u>
1	0229200870	RUBBER SEAL	1	
2	0229201130	RUBBER SEAL	1	
3	0229201240	RUBBER SEAL	3	
4	0228900660	RUBBER SEAL	2	
5	0229201070	RUBBER SEAL	1	
6	0229200125	RUBBER SEAL	4	
7	0228901165	RUBBER SEAL	3	
8	0228900925	RUBBER SEAL	4	
9	0228901105	RUBBER SEAL	3	
10	0228900565	RUBBER SEAL	1	
11	0228900945	RUBBER SEAL	4	
12	0228800505	RUBBER SEAL	1	
13	0229201200	RUBBER SEAL	1	
14	0228800635	RUBBER SEAL	1	
15	0228800970	RUBBER SEAL	2	
16	0228800595	RUBBER SEAL	1	
17	0228100640	RUBBER SEAL	2	
18	0228100370	RUBBER SEAL	2	

DCA-125USJ (50 HZ)— NAMEPLATE AND DECALS ASSY.

NAMEPLATE AND DECALS ASSY.

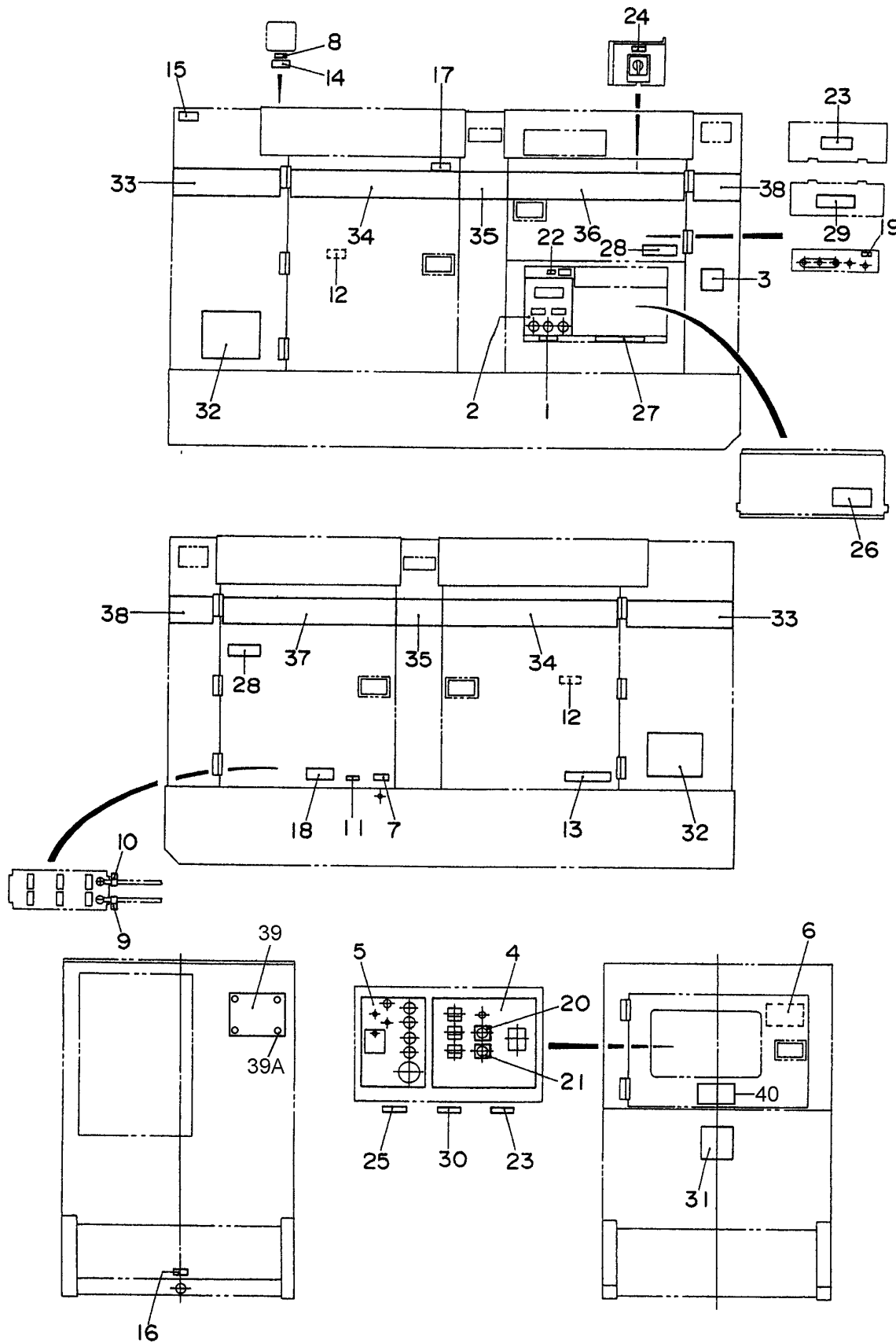

DCA-125USJ (50 HZ)— NAMEPLATE AND DECALS ASSY.

NAMEPLATE AND DECALS ASSY.

<u>NO.</u>	<u>PART NO.</u>	<u>PART NAME</u>	<u>QTY.</u>	<u>REMARKS</u>
1	M1550000204	DECAL, NOTE	1	M15000020
2	M1550000703	DECAL, AUXILARY OUTPUT	1	M15000070
3	M3550000004	DECAL, NOTE	1	M35000000
4	M3550001603	DECAL, GENERATOR CONTROL	1	M35000160
5	M3550001703	DECAL, ENGINE OPERATING, M35000170	1	S/N 8500001 TO 8500040
5	M3550002003	DECAL, ENGINE OPERATING, M35000200	1	S/N 8500041~
6	M3550001803	DECAL, OPERATING PROCEDURES	1	M35000180A
7	M9500000004	DECAL, OIL DRAIN PLUG	1	M90000000
8	M9500100004	DECAL, WATER	1	M90010000
9	M9500300004	DECAL, NEGATIVE	1	M90030000
10	M9500300104	DECAL, POSITIVE	1	M90030010
11	M9500500004	DECAL, DIESEL FUEL	1	M90050000
12	M9503000004	DECAL, WARNING MOVING PARTS	2	M90300000
13	M9503000103	DECAL, WATER OIL CHECK	1	M90300010
14	M9503100004	DECAL, WARNING HOT COOLANT	1	M90310000
15	M9503200004	DECAL, WARNING ENGINE EXHAUST	1	M90320000
16	M9510000004	DECAL, FLUID DRAIN	1	M91000000
17	M9510100004	DECAL, CAUTION HOT PARTS	1	M91010000
18	M9510100403	DECAL, CAUTION	1	M91010040
19	M9520000004	DECAL, GROUND	1	M92000000
20	M9520000104	DECAL, AMMETER CHANGE-OVER SW.	1	M92000010
21	M9520000204	DECAL, VOLTMETER CHANGE-OVER SW.	1	M92000020
22	M9520000504	DECAL, START CONTACT	1	M92000050
23	M9520100004	DECAL, WARNING ELECTRIC HAZARD	2	M92010000
24	M9520100204	DECAL, CAUTION	1	M92010020A
25	M9520100304	DECAL, SAFETY INSTRUCTIONS	1	M92010030
26	M9520100404	DECAL, DANGER HIGH VOLTAGE	1	M92010040
27	M9520100503	DECAL, WARNING	1	M92010050
28	M9520100603	DECAL, CAUTION	2	M92010060
29	M9520200003	DECAL, CONNECTION OF OUTPUT CABLE ..	1	M92020000
30	M9520200104	DECAL, OVER CURRENT RELAY	1	M92020010
31	M9512200004	DECAL, MQ	1	M91220000
32	M9510200304	DECAL, MQ POWER	3	
33	M3560102004	STRIPE	2	
34	M3560102103	STRIPE, WHISPERWATT	2	
35	M3560102204	STRIPE	2	
36	M3560102303	STRIPE, 125	1	
37	M3560102403	STRIPE, 125	1	
38	M3560102504	STRIPE	2	
39	0600500092	PLATE, MQ POWER	1	S/N 8400031~
39A	0021106016	MACHINE SCREW	4	S/N 8400031~
40	M9510100304	DECAL, ENVIRONMENTAL WARNIN6	1	S/N 8400031~

PAYMENT TERMS

Terms of payment for parts are net 10 days.

FREIGHT POLICY

All parts orders will be shipped collect or prepaid with the charges added to the invoice. All shipments are F.O.B. point of origin. Multiquip's responsibility ceases when a signed manifest has been obtained from the carrier, and any claim for shortage or damage must be settled between the consignee and the carrier.

MINIMUM ORDER

The minimum charge for orders from Multiquip is \$15.00 net. Customers will be asked for instructions regarding handling of orders not meeting this requirement.

RETURNED GOODS POLICY

Return shipments will be accepted and credit will be allowed, subject to the following provisions:

1. A Returned Material Authorization must be approved by Multiquip prior to shipment.
2. To obtain a Return Material Authorization, a list must be provided to Multiquip Parts Sales that defines item numbers, quantities, and descriptions of the items to be returned.
 - a. The parts numbers and descriptions must match the current parts price list.
 - b. The list must be typed or computer generated.
 - c. The list must state the reason(s) for the return.
 - d. The list must reference the sales order(s) or invoice(s) under which the items were originally purchased.
 - e. The list must include the name and phone number of the person requesting the RMA.
3. A copy of the Return Material Authorization must accompany the return shipment.
4. Freight is at the sender's expense. All parts must be returned freight prepaid to Multiquip's designated receiving point.

5. Parts must be in new and resalable condition, in the original Multiquip package (if any), and with Multiquip part numbers clearly marked.
6. The following items are not returnable:
 - a. Obsolete parts. (If an item is in the price book and shows as being replaced by another item, it is obsolete.)
 - b. Any parts with a limited shelf life (such as gaskets, seals, "O" rings, and other rubber parts) that were purchased more than six months prior to the return date.
 - c. Any line item with an extended dealer net price of less than \$5.00.
 - d. Special order items.
 - e. Electrical components.
 - f. Paint, chemicals, and lubricants.
 - g. Decals and paper products.
 - h. Items purchased in kits.
7. The sender will be notified of any material received that is not acceptable.
8. Such material will be held for five working days from notification, pending instructions. If a reply is not received within five days, the material will be returned to the sender at his expense.
9. Credit on returned parts will be issued at dealer net price at time of the original purchase, less a 15% restocking charge.
10. In cases where an item is accepted, for which the original purchase document can not be determined, the price will be based on the list price that was effective twelve months prior to the RMA date.
11. Credit issued will be applied to future purchases only.

PRICING AND REBATES

Prices are subject to change without prior notice. Price changes are effective on a specific date and all orders received on or after that date will be billed at the revised price.

Rebates for price declines and added charges for price increases will not be made for stock on hand at the time of any price change.

Multiquip reserves the right to quote and sell direct to Government agencies, and to Original Equipment Manufacturer accounts who use our products as integral parts of their own products.

SPECIAL EXPEDITING SERVICE

A \$35.00 surcharge will be added to the invoice for special handling including bus shipments, insured parcel post or in cases where Multiquip must personally deliver the parts to the carrier.

LIMITATIONS OF SELLER'S LIABILITY

Multiquip shall not be liable here under for damages in excess of the purchase price of the item with respect to which damages are claimed, and in no event shall Multiquip be liable for loss of profit or good will or for any other special, consequential or incidental damages.

LIMITATION OF WARRANTIES

No warranties, express or implied, are made in connection with the sale of parts or trade accessories nor as to any engine not manufactured by Multiquip. Such warranties made in connection with the sale of new, complete units are made exclusively by a statement of warranty packaged with such units, and Multiquip neither assumes nor authorizes any person to assume for it any other obligation or liability whatever in connection with the sale of its products. Apart from such written statement of warranty, there are no warranties, express, implied or statutory, which extend beyond the description of the products on the face hereof.

OPERATION AND PARTS MANUAL

HERE'S HOW TO GET HELP

PLEASE HAVE THE MODEL AND SERIAL
NUMBER *ON-HAND* WHEN CALLING

MQ POWER CORPORATE OFFICE

18910 Wilmington Ave. 800-421-1244
Carson, CA 90746 FAX:310-632-2656
Email:mqpower@multiquip.com
Internet:www.mqpower.com

PARTS DEPARTMENT

800-427-1244 FAX:800-672-7877
310-537-3700 FAX:310-637-3284

SERVICE DEPARTMENT

800-835-2551 FAX:310-638-8046
310-537-3700

TECHNICAL ASSISTANCE

800-478-1244 FAX:310-631-5032

WARRANTY DEPARTMENT

800-835-2551, EXT.279 FAX:310-638-8046
310-537-3700, EXT.279

Manufactured for Multiquip Inc.
by
DENYO CO., LTD, JAPAN

Your Local Dealer is:



MQ POWER

A Division of Multiquip Inc.

POST OFFICE BOX 6254

CARSON, CA 90749

310-537-3700 • 800-421-1244

FAX:310-632-2656

E-mail:mqpower@multiquip.com

Internet:www.mqpower.com

Free Manuals Download Website

<http://myh66.com>

<http://usermanuals.us>

<http://www.somanuals.com>

<http://www.4manuals.cc>

<http://www.manual-lib.com>

<http://www.404manual.com>

<http://www.luxmanual.com>

<http://aubethermostatmanual.com>

Golf course search by state

<http://golfingnear.com>

Email search by domain

<http://emailbydomain.com>

Auto manuals search

<http://auto.somanuals.com>

TV manuals search

<http://tv.somanuals.com>