

PARTS AND OPERATION MANUAL

MULTIQUIP Model GA-6HZ A.C. GENERATOR

© COPYRIGHT 2001, MULTIQUIP INC.

Revision #4 (10/08/04)



MULTIQUIP INC.

18910 WILMINGTON AVE.
CARSON, CALIFORNIA 90746
310-537-3700
800-421-1244
FAX: 310-537-3927

PARTS DEPARTMENT:

800-427-1244
FAX: 800-672-7877

SERVICE DEPARTMENT/TECHNICAL ASSISTANCE:

800-478-1244
FAX: 310-631-5032

E-mail: mq@multiquip.com • www.multiquip.com

Atlanta • Boise • Dallas • Houston • Newark
Montreal, Canada • Manchester, UK
Rio De Janeiro, Brazil • Guadalajara, Mexico

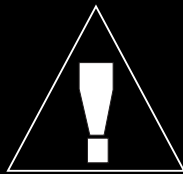

WARNING

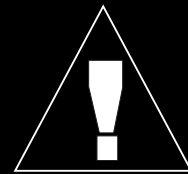

CALIFORNIA — Proposition 65 Warning

Engine exhaust and some of its constituents are known to the State of California to cause cancer, birth defects and other reproductive harm.

HERE'S HOW TO GET HELP

*PLEASE HAVE THE MODEL AND SERIAL NUMBER
ON-HAND WHEN CALLING*

PARTS DEPARTMENT

800-427-1244 or 310-537-3700

FAX: 800-672-7877 or 310-637-3284

SERVICE DEPARTMENT/TECHNICAL ASSISTANCE

800-478-1244 or 310-537-3700

FAX: 310- 537-4259

WARRANTY DEPARTMENT

888-661-4279, or 310-661-4279

FAX: 310- 537-1173

MAIN

800-421-1244 or 310-537-3700

FAX: 310-537-3927

TABLE OF CONTENTS

Here's How To Get Help	3
Table Of Contents	4
Parts Ordering Procedures	5
Rules For Safe Operation	6
Operation and Safety Decals	7
Specifications	8
General Information	9

Multiquip GA-6HZ— AC Generator

Controls and Indicators	10
Installation	11
Pre-Setup	12-13
Instrumentation	14
Load Application	15
Operating Instructions	16
Maintenance	17
Preparation For Long Term Storage	18
Wiring Diagram	19
Troubleshooting (Engine)	20-221
Troubleshooting (Generator)	22-23
Explanation Of Codes In Remarks Column	24
Suggested Spare Parts	25
Generator Assembly	26-27
Control Box Assembly	28-29
Pipe Frame Assembly	30-31
Muffler Assembly	32-33
Nameplate Assembly	34-35

Honda GX340K1 Engine

Cylinder Head Assembly	36-37
Recoil Starter Assembly	38-39
Fan Cover Assembly	40-41
Camshaft/Valves Assembly	42-43
Piston/Rings Assembly	44-45
Air Cleaner Assembly	46-47
Cylinder Barrel (Recoil) Assembly	48-49
Cylinder Barrel (Electric) Assembly	50-51
Crankcase Cover/Governor Assembly	52-53
Flywheel/Fan Assembly	54-55
Coil Assembly	56-57
Crankshaft Assembly	58-59
Electric Start Assembly	60-61
Governor Controls Assembly	62-63
Carburetor Assembly	64-65
Solenoid Assembly	66-67
Fuel Cock Assembly	68-69

Terms and Conditions Of Sale — Parts	70
--	----

NOTE

Specification and part number are subject to change without notice.

PARTS ORDERING PROCEDURES

- Dealer account number
- Dealer name and address
- Shipping address (if different than billing address)
- Return fax number
- Applicable model number
- Quantity, part number and description of each part
- Specify preferred method of shipment:
 - UPS Ground
 - UPS Second Day or Third Day*
 - UPS Next Day*
 - Federal Express Priority One (please provide us with your Federal Express account number)*
 - Airborne Express*
 - Truck or parcel post

**Normally shipped the same day the order is received, if prior to 2PM west coast time.*

Earn Extra Discounts when you order by FAX!

All parts orders which include complete part numbers and are received by fax qualify for the following extra discounts:

<u>Number of line items ordered</u>	<u>Additional Discount</u>
1-9 items	3%
10+ items**	5%

Get special freight allowances when you order 10 or more line items via FAX! **

- UPS Ground Service at no charge for freight
- PS Third Day Service at one-half of actual freight cost

No other allowances on freight shipped by any other carrier.

**Common nuts, bolts and washers (all items under \$1.00 list price) do not count towards the 10+ line items.

DISCOUNTS ARE SUBJECT TO CHANGE

Fax order discount and UPS special programs revised June 1, 1995

**Extra Fax Discount
for Domestic USA
Dealers Only**

**Up to 5%
extra savings!**

**UPS
Special**
For faxed orders only

**Now! Direct TOLL-FREE access
to our Parts Department!**

Toll-free nationwide:

800-421-1244

Toll-free FAX:

800/6-PARTS-7 • 800-672-7877

CAUTION:



Failure to follow instructions in this manual may lead to serious injury or even death! This equipment is to be operated by trained and qualified personnel only! This equipment is for industrial use only.

The following safety guidelines should always be used when operating the GA-6HZRGenerator:

GENERAL SAFETY

- **DO NOT** operate or service this equipment before reading this entire manual.
- This equipment should not be operated by persons under 18 years of age.
- **NEVER** operate this equipment without proper protective clothing, shatterproof glasses, steel-toed boots and other protective devices required by the job.
- This generator is a source of potentially **LETHAL** high voltage. Never permit unqualified personnel-especially children to operate the generator.
- Always refuel in a well-ventilated area, away from sparks and open flames.
- Always use extreme caution when working with **flammable** liquids. When refueling, **stop the engine** and allow it to cool. **DO NOT smoke** around or near the machine. Fire or explosion could result from fuel vapors, or if fuel is spilled on a hot engine.
- This generator is equipped with a **ground terminal** for your protection. Always complete the grounding path from the generator to an external grounding source.
- **NEVER** operate this generator, or handle any electrical equipment while standing in **water, while bare foot, while hands are wet, or in the rain**. *Electrical shock could occur causing severe bodily harm or even death.*
- Keep electrical cords in good condition. Worn, bare or frayed wiring can cause electrical shock, leading to *bodily harm or even death.*
- This generator requires an adequate free flow of cooling air. Never operate the generator in any enclosed or narrow area where free flow of the air is restricted. If the air flow is restricted it will cause serious damage to the generator and may cause injury to people.
- **NEVER** touch the hot exhaust manifold, muffler or cylinder. Allow these parts to cool before servicing generator.

- Provide adequate ventilation when operating the generator. **DO NOT** operate the generator in any enclosed or narrow space. The generator's gasoline engine gives off **DEADLY** carbon monoxide gas.
- **NEVER** operate the generator in an explosive atmosphere or near combustible materials. An explosion or fire could result causing severe *bodily harm or even death.*
- Always make sure that the generator is secure on level ground so that it cannot slide or shift around, endangering workers. Also keep the immediate area free of bystanders.
- When using a concrete vibrator or a similar device that is immersed in a water based solution, make sure the device is equipped with short circuit protection.
- Always use rubber boots and gloves when operating a concrete vibrator or similar device.
- Use adequate size connecting cable for extension.
- Maintain electrical cords in good condition and frequently replace the entire cable of the concrete vibrator with a new one.
- **High Temperatures** – Allow the machine and engine to cool before adding fuel or performing service and maintenance functions. Contact with *hot* components can cause serious burns.

Emergencies

- Always know the location of the nearest **fire extinguisher** and **first aid kit**. Know the location of the nearest telephone. Also know the phone numbers of the nearest **ambulance, doctor** and **fire department**. This information will be invaluable in the case of an emergency.

Maintenance Safety

- **NEVER** lubricate components or attempt service on a running machine.
- Always allow the machine a proper amount of time to cool before servicing.
- Keep the machinery in proper running condition.
- Fix damage to the machine immediately and always replace broken parts.
- Dispose of hazardous waste properly. Examples of potentially hazardous waste are used motor oil, fuel and fuel filters.
- **DO NOT** use food or plastic containers to dispose of hazardous waste.
- **DO NOT** pour waste, oil or fuel directly onto the ground, down a drain or into any water source

OPERATION AND SAFETY DECALS

Machine Safety Decals

The GA-6HZ portable generator is equipped with a number of safety decals. These decals are provided for operator safety and maintenance information. The illustration below shows these decals as they appear on the machine. Should any of these decals become unreadable, replacements can be obtained from your dealer.



P/N 7900631302



P/N 7900636004

OPERATING INSTRUCTIONS

1. Before starting check the oil and fuel level.
2. Switch the circuit breaker to the "OFF" position.
3. Open the fuel valve.
4. Pull the choke knob.
5. Turns the operation switch to the "RUN" position and push
6. Pull the recoil starter.
7. After the engine starts, gradually push in the choke valve.
8. Run the generator for 3-5 minutes without load.
9. Check for any abnormal noise or smell.
10. Switch the circuit breaker to the "ON" position.
11. When stopping, remove the load and allow it to continue to run for 2-3 minutes before stopping engine.
12. Turns the operation switch to the "STOP" position.
13. After the engine completely stops, close the fuel valve.

P/N 7900638204

S-4607

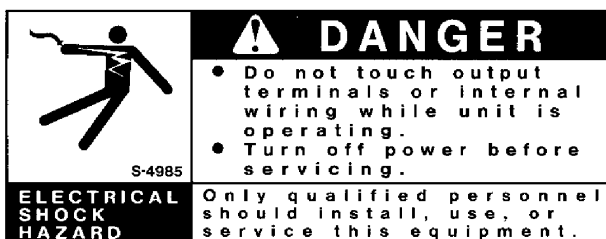

P/N 8700611904

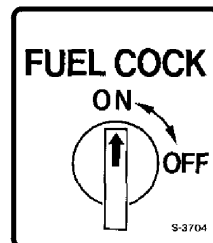

P/N 1980680004

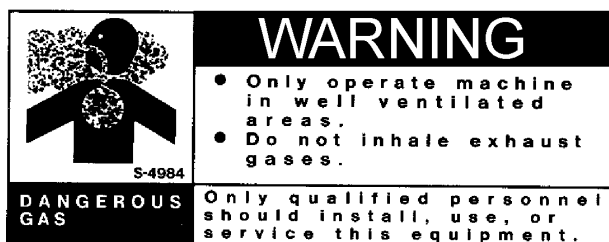

P/N 8700611804

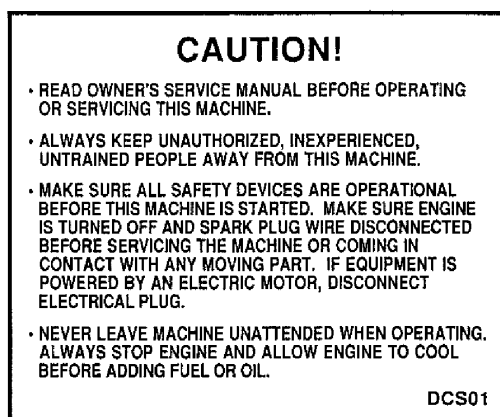

P/N 0820610804

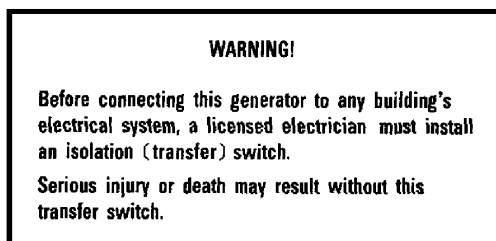

P/N 0820610404

GROUND



P/N 0800628504

Table 1. Specifications

MODEL		GA-6HZ
	Type	2-pole, Brushless Type Revolving Field
60 Cycle Generator	Max. Output	5500 Watts
	Rated Output (continuous)	5000 Watts
	Rated Voltage	120/240 V
	Rated Current	21 Amps
	Phase	Single Phase (4-wire)
	Frequency	60 Hz
	Rated Speed	3600 RPM
	Power Factor	100%
Engine	Model	Honda GX340K1VD
	Type	Air-cooled 4 stroke OVH 90 V- Twin horizontal shaft gasoline engine
	Bore X Stroke	1-3.23 in. X 2.52 in.
	Displacement	20.63 cc
	Max Output	11 H.P./3600 R.P.M.
	Fuel Tank Capacity	Approx. 5 U.S. Gallons
	Fuel	Unleaded Automobile Gasoline
	Lube Oil Capacity	2 1/3 pints
	Speed Control Method	Centrifugal Fly-weight Type
	Starting Method	Recoil/Electric Start
Dimension (LXWXH)		780 X 515 X 480 mm
Dry Net Weight		216 lbs (98 Kg.)

Effects of Altitude and Heat

The maximum output of the engine listed above is applicable to supplying electrical power for continuous service at ambient conditions in accordance with SAE Test cord J607. The above ambient conditions are at standard sea level, with a barometric reading of 29.92 inches and a temperature of 60 degrees fahrenheit.

Generally, the engine output power will decrease 3 1/2% for each 1000 feet of altitude above sea level, and 1% for each 10° F fahrenheit above the standard temperature of 60° F

WARNING:



Before connecting this generator to any building's electrical system, a licensed electrician must install an isolation (transfer) switch.

Serious injury or death may result without this transfer switch.

GA-6HZ FAMILIARIZATION

Generator

The Multiquip Model GA-6HZ generator has been designed as a portable lightweight power source for 60 Hz (single-phase) vibrators, lighting facilities, power tools, submersible pumps and other industrial and construction machinery.

This generator is powered by a **HONDA** gasoline engine. The alternator, a brushless revolving-field type, is permanently aligned to the engine through rigid coupling.

The generator is mounted on rubber vibration isolators that have a steel base backplate which is attached to the protective steel pipe carrying frame. The protective carrying frame is made of steel tubing and fully wraps around the generator to protect against damage.

This portable generator is supplied with a electrical **control box**. To reduce vibration caused by the engine, the control box is also placed on rubber isolators.

Control Box

The control box has the following: (all outputs are 60 Hz, single phase)

- One 120V output receptacle.
- One 240V output receptacle.
- One 120V output receptacle (GFI protected).
- One main 21 amp circuit breaker.
- AC Voltmeter
- Idle Control Switch
- Full Power Switch
- Operation Switch

Excitation System

All GA-series generators use a magnet attached to a flywheel to produce AC voltage from a lamp coil beneath the flywheel. As the magnet passes the coil it produces approximately 19-22 AC volts.

This voltage (19-22 VAC) is then sent to the control box that contains three rectifying diodes:

- Excitation (diode 1)
- Battery (diode 2)
- Slow Down (diode 3)

The AC voltage will pass through the excitation diode that converts the voltage to DC power.

This DC power is then sent to the excitation windings housed within the main windings commonly called the "stator".

This voltage is then transferred into the rotor through induction. The rotor contains two diodes within it which rectify the DC voltage and send it out through the main windings, as AC voltage.

Engine

The four-cycle air-cooled HONDA gasoline engine is designed to meet every performance requirement of this generator. Reference Table 1, page 8 for engine specifications.

Figure 1 (page 10) shows the basic controls and indicators for the GA-6HZ generator.

NOTE

In keeping with Multiquip's policy of constantly improving its products, the specifications quoted herein are subject to change without prior notice.

GA-6HZ — CONTROLS AND INDICATORS

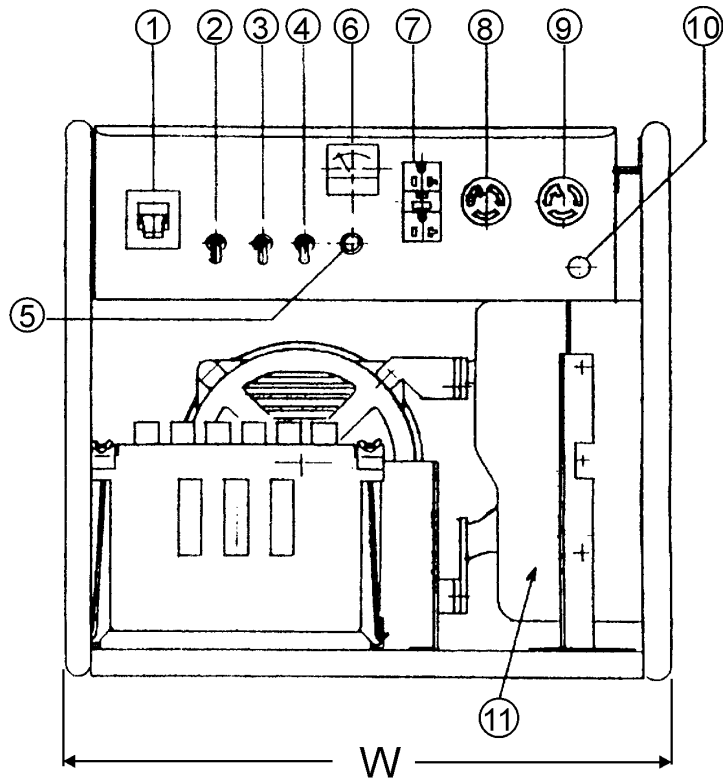

NO.	PARTS NAME
1	CIRCUIT BREAKER
2	FULL POWER SWITCH
3	IDLE CONTROL SWITCH
4	OPERATION SWITCH
5	START SWITCH
6	AC VOLTMETER
7	RECEPTACLE (120V, GFCI)
8	RECEPTACLE (120V)
9	RECEPTACLE (240V)
10	GROUND TERMINAL
11	MUFFLER
12	FUEL TANK
13	BATTERY

L	W	H
780 MM (30.70 IN)	515 MM (20.27 IN)	480 MM (18.90 IN)

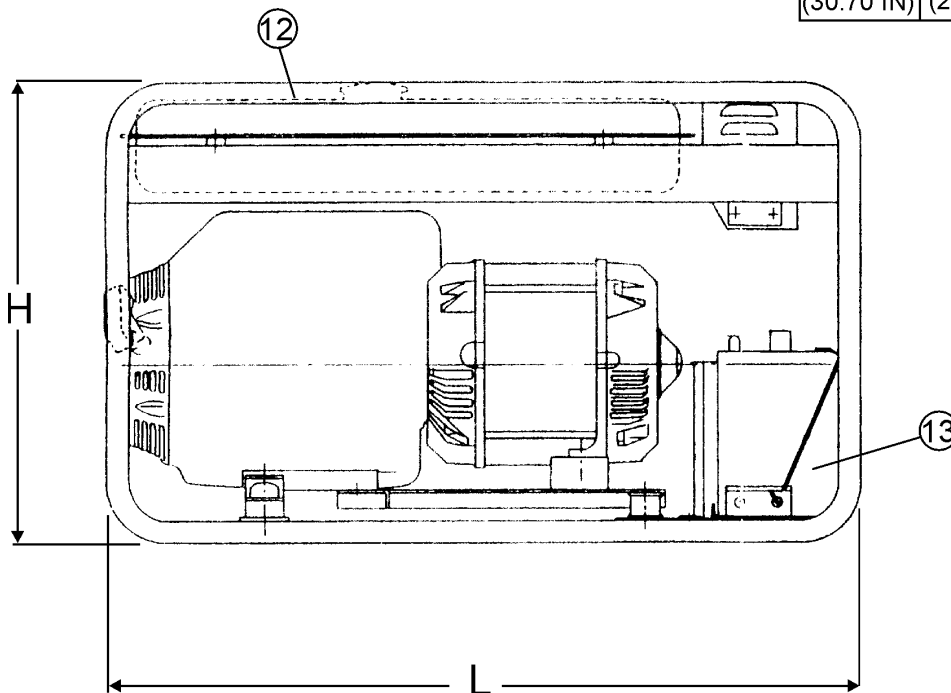

Figure 1. Controls and Indicators

Outdoor Installation

Install the generator in a location where it will not be exposed to rain or sunshine. Make sure that the generator is on secure level ground so that it cannot slide or shift around. Also install the generator in a manner so that the exhaust will not be discharged in the direction of nearby homes.

The installation site must be relatively free from moisture and dust. All electrical equipment should be protected from excessive moisture. Failure to do so will result in deterioration of the insulation and will result in short circuits and grounding.

Foreign materials such as dust, sand, lint and abrasive materials have a tendency to cause excessive wear, not only to the engine parts, but also to the alternator parts.

CAUTION :



Pay close attention to ventilation when operating the generator inside confined areas. The engine exhaust contains noxious elements.

Indoor Installation

Exhaust gases from gasoline engines are extremely poisonous. Whenever an engine is installed indoors the exhaust fumes must be vented to the outside. The engine should be installed at least two feet from any outside wall. Using an exhaust pipe which is too long or too small can cause excessive back pressure which will cause the engine to heat excessively and possibly burn the valves.

Eliminate the danger of deadly carbon monoxide gas. Remember that exhaust fumes from any gasoline engine are very poisonous if discharged in a closed room, but harmless if allowed to mix with the outside air. If the generator is installed indoors, you must make provisions for venting the engine exhaust to the outside of the building.

CAUTION :

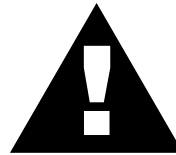

An electric shock is apt to happen when vibrators are used. Pay close attention to handling when operating vibrators and always use rubber boots and gloves to insulate the body from a short circuit.

General Inspection Prior to Operation

This generator has been thoroughly inspected and accepted prior to shipment from the factory. However, be sure to check for damaged parts or components, or loose nuts and bolts, which could have occurred in transit.

Circuit Breaker

To protect the generator from an overload, a 2-pole 13.5 amp circuit breaker is provided on the control box. Make sure to switch this circuit breaker to the "OFF" position prior to starting the engine.

Ground

The nut and ground terminal on the generator should always be used to connect the generator to a suitable ground. The ground path should be of #8 size wire.

Connect the terminal of the ground wire between the lock washer and the nut and tighten the nut fully. Connect their end of the wire to a suitable ground.

Extension Cable

When electric power is to be provided to various tools or loads at some distance from the generator, extension cords are normally used. Cables should be sized to allow for distance in length and amperage so that the voltage drop between the generator and point of use (load) is held to a minimum. Use the cable selection chart (Table 2) as a guide for selecting proper cable size.

Table 2. Cable Selection (60 Hz, single phase operation)

Current in Amperes	Load In Watts		Maximum Allowable Cable Length			
	At 120 Volts	At 240 Volts	#10 Wire	#12 Wire	#14 Wire	#16 Wire
2.5	300	600	1000 ft.	600 ft.	375 ft.	250 ft.
5	600	1200	500 ft.	300 ft.	200 ft.	125 ft.
7.5	900	1800	350 ft.	200 ft.	125 ft.	100 ft.
10	1200	2400	250 ft.	150 ft.	100 ft.	
15	1800	3600	150 ft.	100 ft.	65 ft.	
20	2400	4800	125 ft.	75 ft.	50 ft.	
CAUTION: Equipment damage can result from low voltage.						

Lubrication Oil

Fill the engine crankcase with lubricating oil through the filler hole, but do not overfill. Make sure the generator is level. With the dipstick inserted all the way, but without being screw into the filler hole, verify that the oil level is maintained between the two notches on the dipstick.

The oil listed in Table 3 is recommended to ensure better engine performance. Use class SC or higher grade motor oil.

NOTE

This HONDA engine is equipped with a low oil shutdown capability. A built in sensor will automatically turn off the engine should the oil level fall below a safe operating condition. Make sure the generator is placed on level ground. Placing the generator on level ground will ensure that the low oil sensor will function properly.

Fuel

Close the fuel cock before filling the tank. Fill the fuel tank with clean and fresh unleaded gasoline. Do not fill the tank beyond capacity.

Pay attention to the fuel tank capacity when replenishing fuel. Refer to the fuel tank capacity listed on page 8 Specification Table 1.

The fuel tank cap must be closed tightly after filling.

Handle fuel in a safety container. If the container does not have a spout, use a funnel.

CAUTION :

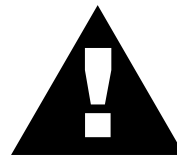

Never fill the fuel tank while the engine is running or in the dark. Gasoline spillage on a hot engine can cause a fire or explosion. If gasoline spillage occurs, wipe

Table 3. Recommended Motor Oil

Temperature Range	Type Oil
104° F ~ 23° F (40° C ~ -5°C)	SAE 30
23° F ~ 5° F (-5° C ~ -15°C)	SAE 20 or SAE 10W-30
Below 5° C (-15°)	SAE 10W or SAE 10W-30

CAUTION :



When using a combination of dual receptacles, total load should not exceed the rated capacity of the generating.

Power Outlets

The generator has the following 120/240 volt 60 Hz (single-phase) receptacles.

- Single Phase
 - One Duplex NEMA (GFCI) 5-20R (120V, 20 Amp)
 - One Twist Lock NEMA L5-30R (120V, 30 Amp)
 - One Twist Lock NEMA L6-20R (240V, 20 Amp)

Main Circuit Breaker (2-Pole 120/240V 60 Hz)

This 2-pole 21 amp breaker protects the generator from short circuiting or overloading from the 120/240V 60 Hz single phase load.

Idle Control Switch

This unit is provided with an automatic idle control for noise suppression and reduced fuel consumption. The automatic idle control automatically engages under a no-load condition. With the automatic idle control switched "ON", the engine revolutions will automatically drop to about 2500 rpm (low-speed operation) within 3 seconds after the load stops. When the operation is resumed, the engine speed is automatically increased to about 3600 rpm (high-speed operation) as soon as the load is connected.

Fuel Gauge

The fuel gauge is located on the fuel tank and allows easy monitoring of the fuel level.

AC Voltmeter

This voltmeter indicates (with a mark) the rated 60 Hz, single phase output voltage. In addition the voltmeter can also be used as a diagnostic tool.

If the voltmeter indicator (needle) is below the rated voltage, engine problems may exist (low/high RPM's). To prevent damage to the generator or power tools turn the generator OFF and consult your authorized Multiquip service dealer.

Operation Switch

This switch must be in the ON position (up) for normal operation.

Start Switch

Push this switch to start the engine (electric start only). If a recoil starter is used, pull the starter rope to start the engine. Make sure the operation switch is in the ON position (up), otherwise engine will not start.

Full Power Switch

The unit is provided with a full power switch. Figures 2 and 3 show simplified wiring diagrams of the dual voltage system.

When the full power switch is in the 120 volt (up) position, you can take up **full rated power** of the generator at 120 volts from the single duplex receptacle, single locking type 120 volt receptacle, or a combination of these receptacles as long as the total load does not exceed the generating set capacity.

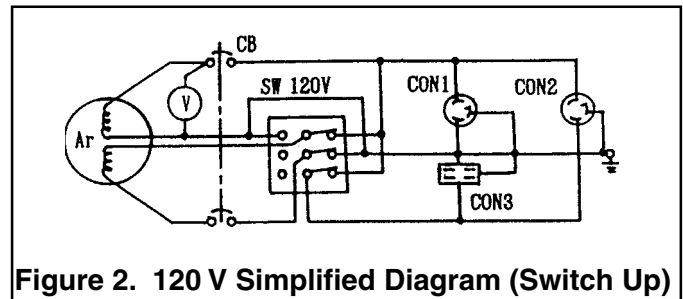

Figure 2. 120 V Simplified Diagram (Switch Up)

NOTE

When the full power switch is in the 120 volt position, the locking type 240 volt receptacle cannot be used.

When the full power switch is in the 240 volt (down) position, you can take up to half of the rated power of the generating set at 120 volts from the duplex receptacle and up to half of the rated power of the set at 120 volts from the locking type 120 volt receptacle; or full rated power of the set at 240 volts from the locking type 240 volt receptacle.

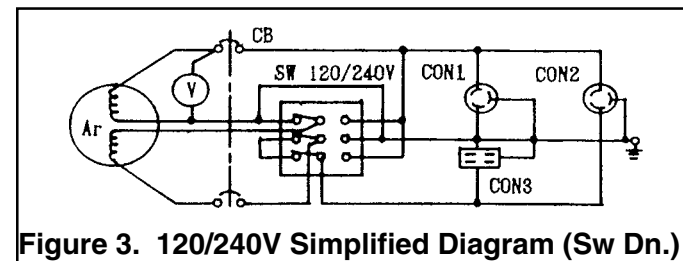

Figure 3. 120/240V Simplified Diagram (Sw Dn.)

Single Phase Load

Always be sure to check the nameplate on the generator and equipment to insure the wattage, amperage and frequency requirements are satisfactorily supplied by the generator for operating the equipment.

Generally, the wattage listed on the nameplate of the equipment is its rated output. Equipment may require 130—150% more wattage than the rating on the nameplate, as the wattage is influenced by the efficiency, power factor and starting system of the equipment.

NOTE

If wattage is not given on the equipment's name plate, approximate wattage may be determined by multiplying nameplate voltage by the nameplate amperage.

WATTS = VOLTAGE x AMPERAGE

To determine the running wattage for your load, multiply the running wattage as indicated by steps 1, 2, and 3 below:

1. INCANDESCENT LOADS

Lights, heaters and similar appliances.

Total the running wattage and multiply by 1.

Example:

29 light bulbs @ 100W each = 2.9 KW

use a 3 KW generator.

2. SMALL MOTORS

Drills and other small power tools.

Total the running wattage and multiply by 2.

Example:

A 1 inch drill runs at 1 KW

use a 2 KW generator.

3. LARGE MOTORS

Submersible pumps, table saws etc.

Total the running wattage and multiply by 3.

Example:

A conveyor belt runs at 8 KW

use a 24 KW generator.

CAUTION:

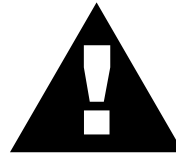

Motors and motor-driven equipment draw much greater current for starting than during operation.

An inadequate size connecting cable which cannot carry the required load can cause a voltage drop which can burn out the appliance or tool and overheat the cable.

The idle control is operated at minimum load capacity of 100W. If the load capacity is less than 100W, throw the idle control switch to the OFF position.

GA-6HZ— OPERATING INSTRUCTIONS

Before Starting

1. Be sure to disconnect the electrical load and switch the main circuit breaker to the "OFF" position prior to starting the engine.
2. Never start the engine with the main circuit breaker "ON".
3. Check the lubricating oil level prior to starting the engine. Make sure the generator is level. The oil level must be maintained between two notches on the dipstick.
4. When there is not enough lubricating oil, fill the crankcase with high grade motor oil. Use a high quality detergent oil classified SC, SD or SE. (See Table 3 on page 13)

CAUTION:



- NEVER start the engine when the oil level is below the lower mark on the dipstick.
- Check the fuel level on the fuel gauge. When fuel is low, fill the fuel tank with clean fresh unleaded automotive gasoline.
- If gasoline spillage occurs, completely wipe up the spilled gasoline.

Starting

1. Open the fuel cock located below the fuel tank. The fuel starts to flow when the fuel cock lever is turned downward.
2. Place the idle control switch in the "ON" (up) position.
3. Close the choke. Adjust the opening of the choke valve according to operating conditions. When the engine is warm or the air temperature is high, close the choke valve halfway or open it all the way.
4. Confirm that the main circuit breaker on the generator control box is "OFF".
5. Set the operation switch to the "ON" position and grasp the starting rope and slowly pull it out. The resistance becomes hardest at a certain position, corresponding to the compression point. Rewind the rope a little from that point and pull out sharply.
6. If the engine fails to start, repeat the procedure.

CAUTION:



- DO NOT pull the starter rope all the way to the end.
- DO NOT release the starter rope after pulling. Allow it to rewind as soon as possible.

Warm up

1. When the engine starts, open the choke slowly.
2. Run the engine at low speed for 3 minutes without load until the engine warms up.
3. Turn the idle control switch to the "OFF" (down) position and check the voltage by referring to the voltmeter on the control box.

CAUTION:

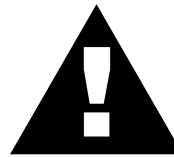

DO NOT change the engine speed control lever which has been set at the factory prior to shipping.

1. Check the generator for abnormal noise and smells. Then connect the load to the receptacles of the generator.
2. Switch the main circuit breaker to the "ON" position and turn the idle control switch to the "ON" (down) position for normal (load) engine operation.

Operation

Check the voltage by referring to the voltmeter on the control box. When the voltmeter indicates 120 volts, 120 volts from the 120V receptacles and 240 volts from the 240V receptacle can be obtained at the same time. Refer to Figure 1, Controls and Indicators, item 6 on page 10.

Stopping the Engine

CAUTION:

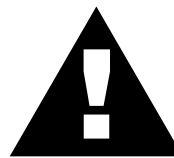

NEVER stop the engine suddenly while running at high speeds.

1. Remove the load from the generator. Place the circuit breaker in the "OFF" position. Refer to Figure 1, item 1 on page 10. Run the engine (no-load) with the idle control switch set to the ON position for three to five minutes, then stop the engine.
2. Turn the START/STOP switch to the "STOP" position.
3. Close the fuel cock.

General Inspection

At least daily or prior to each use, the generating set should be cleaned and inspected for deficiencies. Check for loose, missing or damaged nuts, bolts or other fasteners. Also check for fuel or oil leaks.

Engine Side (Refer to the Engine Instruction Manual)**Check Oil Level**

Check the crankcase oil level prior to each use, or when the fuel tank is filled. Make sure the generating set is level. The oil level must be between the two notches on the dipstick.

Changing Oil

Change oil after the first 20 hours of operation. Drain and refill the engine crankcase every 50 operating hours or once a week thereafter. Drain crankcase oil into a suitable container while engine is still warm. Replace the drain plug tightly. Add oil through the filler hole.

Air Cleaner

Every 50 hours: Remove air cleaner element (std. or heavy duty types), and wash in kerosene or liquid detergent and hot water. Wrap foam element in a cloth and squeeze dry. Wipe heavy duty paper element dry with toweling. Saturate element with kerosene; squeeze excess from foam element. Wipe excess from heavy duty paper element.

Service Daily

If engine is operating in very dusty and dry grass conditions. A clogged air cleaner will result in high fuel consumption, loss of power and excessive carbon buildup in the combustion chamber.

Cleaning the Fuel Strainer

Clean the fuel strainer if it contains dust or water. Remove dust or water in the strainer cap and wash it in gasoline. Securely fasten the fuel strainer cap so that fuel will not leak. Check the fuel strainer every 200 hours of operation or once a month.

Spark Plug

Remove carbon build-up on the spark plug (Figure 4) with a wire brush. Set the spark plug gap to 0.6—0.7mm (0.024-0.028 inch). Tighten with a spark plug socket wrench. Clean the spark plug every 50 operating hours or once a week.

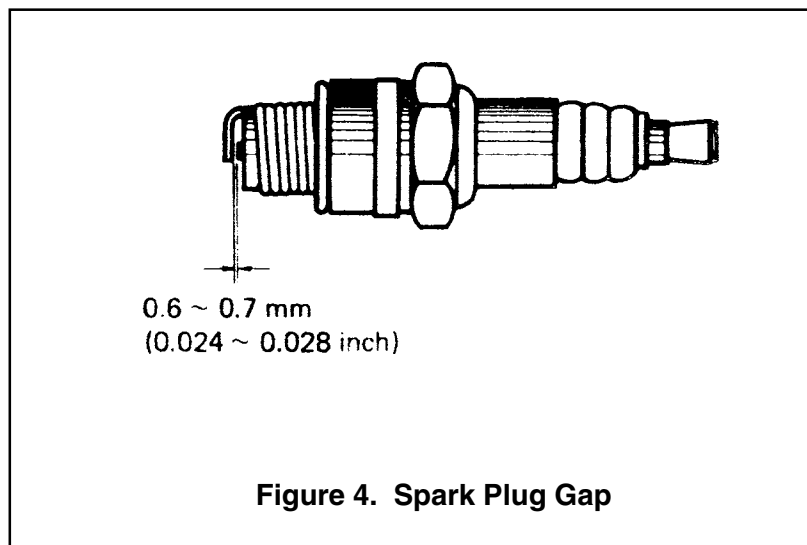

Figure 4. Spark Plug Gap

GA-6HZ— PREPARATION FOR LONG -TERM STORAGE

Generator Storage

For storage of the generating set for over 30 days, the following is required:

- Drain the fuel tank completely.
- Run the engine until the gasoline in the carburetor is completely consumed.
- Completely drain the oil from the crankcase and refill with fresh oil.
- Remove the spark plug, pour 2 or 3 cc of SAE 30 oil into the cylinder and crank slowly to distribute the oil.
- Slowly rotate the engine a few times with the starter Rope and install a new plug.
- Pull out the starter rope slowly and stop at the compression point.
- Clean all external parts of the generating set with a cloth.
- Cover the generating set and store in a clean, dry place.

GENERATOR

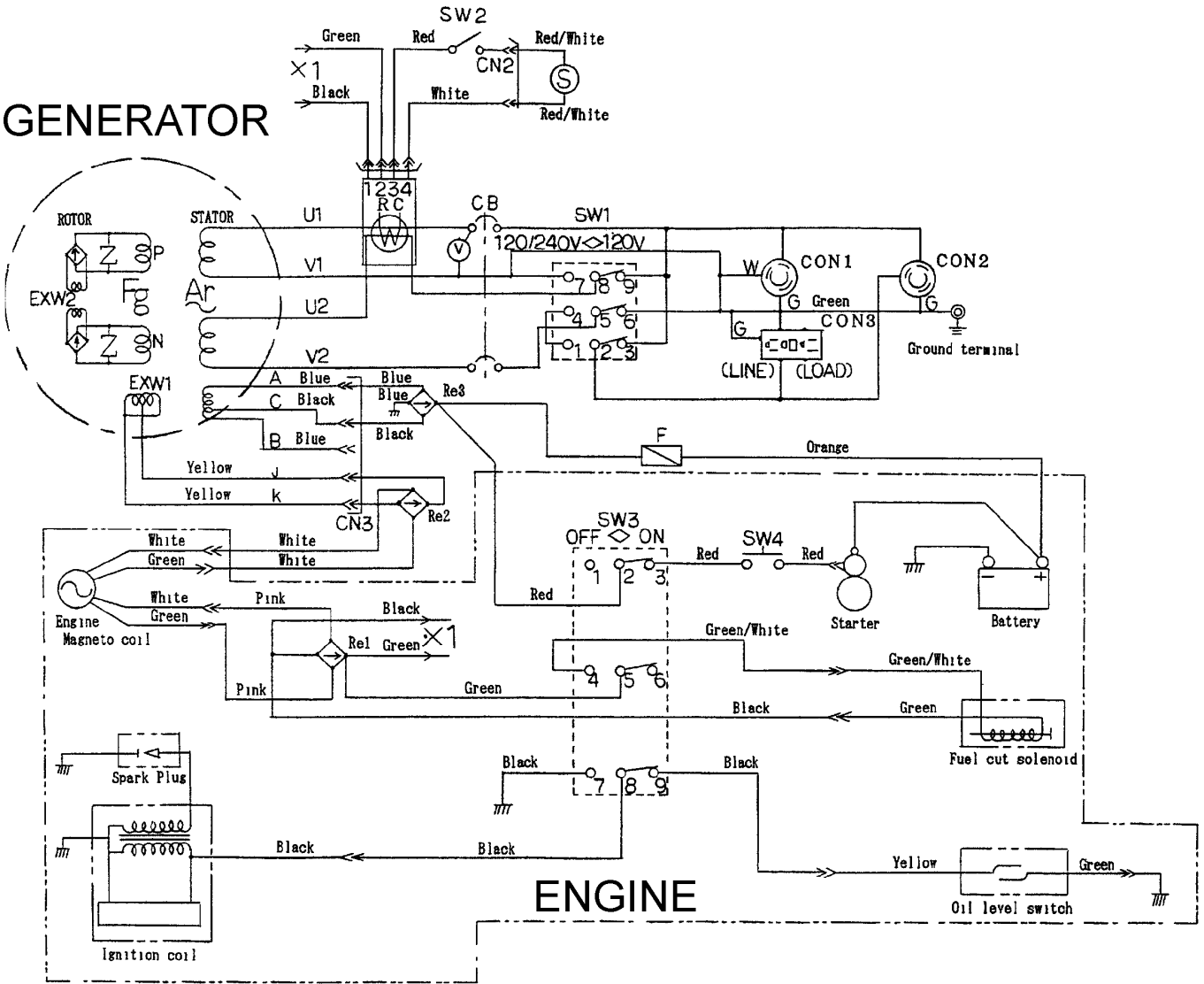

ENGINE

COLOR CODE			
WIRE COLOR		WIRE COLOR	
B	BLACK	R	RED
L	BLUE	W	WHITE
BR	BROWN	Y	YELLOW
G	GREEN	LB	LIGHT BLUE
GR	GRAY	LG	LIGHT GREEN
V	VIOLET	O	ORANGE
P	PINK		



CONNECTOR ARRANGEMENT
(VIEWED AT WINDING SIDE)

SYMBOL	DESIGNATION
Ar	ARMATURE WINDING
Fg	FIELD WINDING
Ex W1~2	EXCITATION WINDING
CON 1	RECEPTACLE 120V
CON 2	RECEPTACLE 240V
CON 3	RECEPTACLE 120V
V	AC VOLTMETER
RE 1~3	RECTIFIER
CB	CIRCUIT BREAKER
SW1	FULL POWER SWITCH
SW2	IDLE CONTROL SWITCH
SW3	OPERATION SWITCH
SW4	STARTER SWITCH
RC	IDLE CONTROL DEVICE
S	IDLE CONTROL SOLENOID
F	FUSE

GA-6HZ—TROUBLESHOOTING (ENGINE)

Practically all breakdowns can be prevented by proper handling and maintenance inspections, but in the event of a breakdown, please take a remedial action following the

diagnosis based on the Engine Troubleshooting (Table 4) information shown below and on the proceeding page. If the problem cannot be remedied, please leave the unit just as it is and consult our company's business office or service plant.

TABLE 4. ENGINE TROUBLESHOOTING

SYMPTOM	POSSIBLE PROBLEM	SOLUTION
Poor starting	Inspect carburetor to see if fuel is reaching it?	Check fuel line
	No Fuel?	Add Fuel
	Water in fuel tank?	Flush or replace fuel tank.
	Fuel filter clogged?	Replace fuel filter
	Stuck carburetor?	Check float mechanism.
	Spark plug is red?	Spark plug is fouled. Check transistor ignition unit.
	Spark plug is blue-white?	Insufficient compression, injected air leaking. Carburetor jets are clogged (overflow).
	No spark present at tip of spark plug?	Transistor ignition unit broken, high voltage cord cracked or broken. Start/Stop switch broken. Replace spark plug if fouled.
	No oil?	Add oil as required.
	Oil pressure alarm lamp blinks upon starting?	Check Automatic shutdown circuit "oil sensor".
Insufficient power output "no compression"	Engine will not turn over?	Replace cylinder and piston and if necessary axel joint.
	Cylinder head connecting bolts loose?	Tighten cylinder head connecting bolts.
	Cylinder head gasket damaged?	Replace cylinder head gasket.
	Malfuction of valve seat?	Re-seat valves.
	Spark plug is loose?	Replace spark plug.
	Worn piston rings?	Replace piston rings.
Insufficient power output "compression"	Malfuction in air-cleaner system, air filter clogged?	Clean or replace air filter.
	Air leaking in from interface between carburetor and cylinder head?	Tighten bolts between carburetor and cylinder head. Replace cylinder head gasket.
	Malfuction in fuel system?	Clean or replace fuel filter. Clean or replace carburetor. Check carburetor float.

TABLE 4. ENGINE TROUBLESHOOTING (CONTINUED)

SYMPTOM	POSSIBLE PROBLEM	SOLUTION
Insufficient power output "compression" and overheats	Malfunction in cooling fan?	Check or replace cooling fan.
	Air in-take filter clogged?	Clean or replace air in-take filter.
Burns to much fuel	Over accumulation of exhaust products?	Clean and check valves. Check muffler, replace if necessary.
	Wrong spark plug?	Replace spark plug with manufactures suggested type spark plug.
Exhaust color is continiously "WHITE"	Lubricating oil is wrong viscosity?	Replace lubricating oil with correct viscosity.
	Worn rings?	Replace rings
Exhaust color is continiously "BLACK"	Air cleanner clogged?	Clean or replace air cleaner.
	Choke valve has not been set to the correct position?	Adjust choke valve to the correct position.
	Carburetor defective, seal on carburetor broken?	Replace carburetor or seal.
	Poor carburetor adjustment "engine runs too rich?"	Adjust carburetor.

GA-6HZ—TROUBLESHOOTING (GENERATOR)

Practically all generator breakdowns can be prevented by proper handling and maintenance inspections, but in the event of a breakdown, please take a remedial action following the

diagnosis based on the Generator Troubleshooting (Table 5) information shown below and on the preceding page. If the problem cannot be remedied, please leave the unit just as it is and consult our company's business office or service plant.

TABLE 5. GENERATOR TROUBLESHOOTING

SYMPTOM	POSSIBLE PROBLEM	SOLUTION
Low voltage	Engine speed too low?	Raise engine speed to rated RPM.
Low voltage. Engine speed normal 3650 RPM (unloaded), 2500 RPM (idle)	AC voltmeter not working?	Replace AC voltmeter.
	Control box internal wiring malfunction?	Check control box wiring.
	Defective ignition coil?	Check red and green ignition wires. Replace ignition wires if necessary.
	Rotor winding malfunction?	Check or replace rotor.
	Stator winding malfunction?	Check or replace stator.
	Leakage breaker malfunction?	Check or replace CB1.
	Full power switch malfunction?	Check full power switch and full power switch circuit.
Voltage output too high.	Engine speed too high?	Lower engine speed to rated RPM.
Voltage output too high. Engine speed normal 3650 RPM (unloaded), 2500 RPM (idle)	Control box internal wiring malfunction	Check control box wiring.
Circuit breaker will not turn on "NO LOAD"	Defective circuit breaker?	Replace circuit breaker.
Circuit breaker will turn on "LOADED" but trips immediately.	Overload?	Reduce load or replace breaker.
	Load circuit is shorted?	Check load circuit for short.
Does not accelerate from low to high "NO LOAD"	Stuck solenoid?	Check solenoid.
	Bad Idle control switch?	Check or replace idle control switch.
Does not accelerate from low to high "LOAD ACTIVE"	Idle control switch malfunction?	Check or replace idle control switch.
	Idle control device malfunction?	Check or replace idle control device.
	Control box internal wiring defective?	Check control box wiring.

GA-6HZ—TROUBLESHOOTING (GENERATOR)

TABLE 5. GENERATOR TROUBLESHOOTING (CONTINUED)

SYMPTOM	POSSIBLE PROBLEM	SOLUTION
Does not decelerate no "VOLTAGE OUTPUT".	Defective rotor windings?	Check or replace rotor.
	Defective solenoid?	Check or replace solenoid.
	Defective idle control device?	Check or replace idle control device.
	Defective solenoid?	Check or replace idle control device.
Does not decelerate but has "VOLTAGE OUTPUT".	Control box wiring malfunction?	Check control box wiring, replace any defective components.
	Defective solenoid?	Check or replace solenoid.
	Idle control device malfunction?	Check or replace idle control device.

GA-6HZ— EXPLANATION OF CODE IN REMARKS COLUMN

How to read the marks and remarks used in this parts book.

Items Found In the “Remarks” Column

Serial Numbers-Where indicated, this indicates a serial number range (inclusive) where a particular part is used.

Model Number-Where indicated, this shows that the corresponding part is utilized only with this specific model number or model number variant.

Items Found In the “Items Number” Column

All parts with same symbol in the number column, *, #, +, %, or ■, belong to the same assembly or kit.

NOTE

If more than one of the same reference number is listed, the last one listed indicates newest (or latest) part available.

NOTE

The contents of this catalog are subject to change without notice.

GA-6HZ 1 TO 5 UNITS WITH HONDA GX340K1EDN2 ENGINE

1 to 5 Units

Qty.	P/N	Description
5	9807955846	SPARK PLUG
1	15510ZE2W01	OIL LEVEL SWITCH
1	15600735700	DIPSTICK
1	28400ZEZW01ZB	RECOIL STARTER
5	17211899000	ELEMENT AIR
1	16100ZEF00	CARBURETOR ASSY.
1	16950ZB4015	FUEL COCK ASSY.
5	0810107103	FUEL FILTER
2	0810106004	CAP, FUEL TANK
2	0601805327	CIRCUIT BREAKER
3	0601823204	RECTIFIER
2	0601812597	RECEPTACLE
2	0601811031	RECEPTACLE, 125V, 30A
2	0601811032	RECEPTACLE, 250V 20A

GA-6HZ— GENERATOR ASSY.

FAN COVER ASSY.

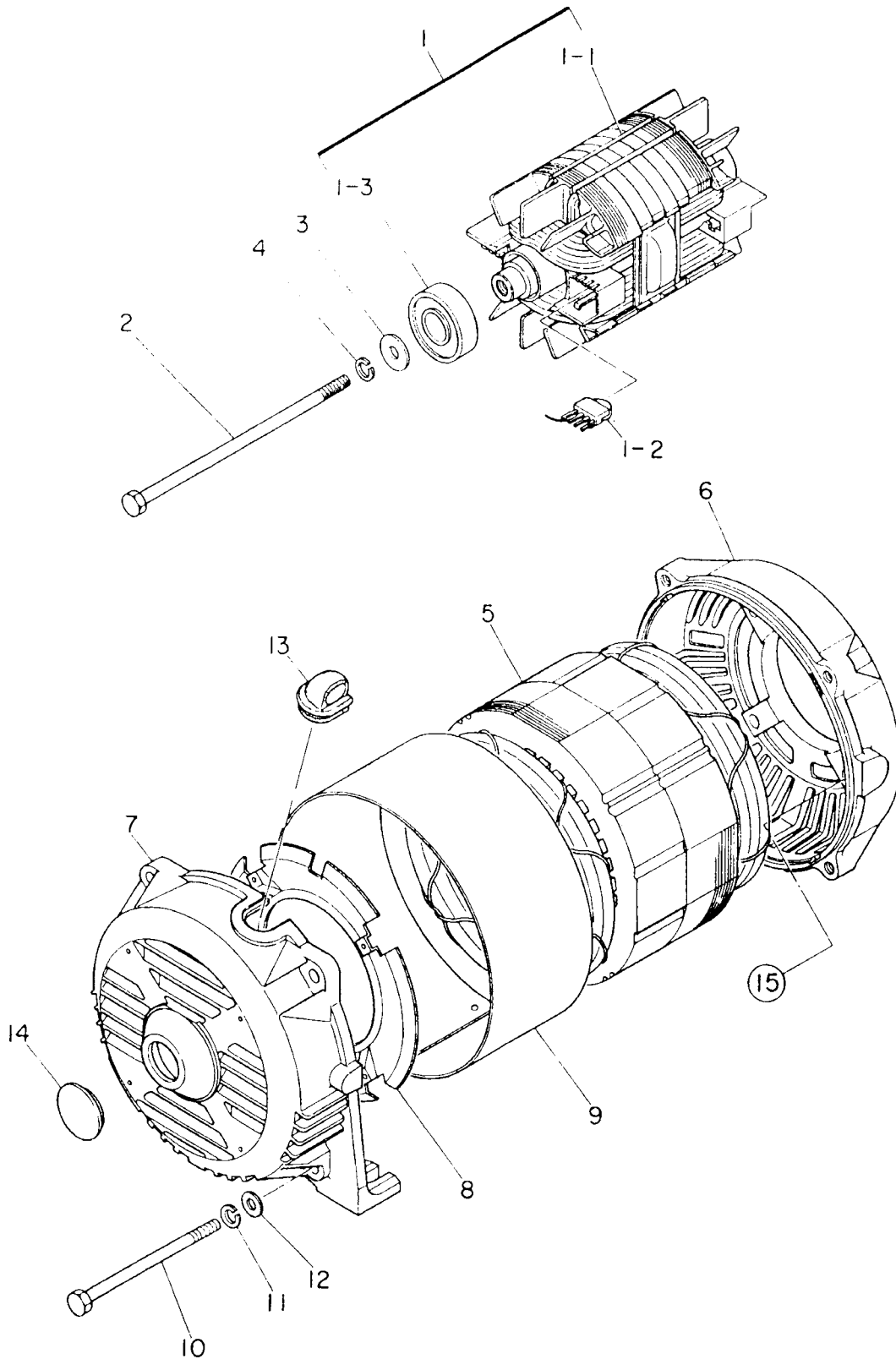

FAN COVER ASSY.

<u>NO</u>	<u>PART NO</u>	<u>PART NAME</u>	<u>QTY.</u>	<u>REMARKS</u>
1	7901002403	ROTOR ASS'Y	1	
1-1		FIELD COIL	1	
1-2	0601823207	RECTIFIER	2	D3SB60 (S)
	0601822638	SURGE ABSORBER	2	TNR15G431K
1-3	0071706304	BEARING	1	6304 2RUNYCM
2	7901017014	SET BOLT, ROTOR	1	
3	0801096104	SET WASHER, BEARING	1	
4	0040010000	SPRING WASHER	1	
5	7901348903	ARMATURE ASSY	1	
6	7901315502	END BRACKET	1	
7	7871315022	END BRACKET	1	
8	7875021513	GUIDE PANEL,AIR	1	
9	7871331003	COVER	1	
10	7901316004	SET BOLT, STATOR	4	
11	0040008000	SPRING WASHER	4	
12	0041208000	PLAIN WASHER	4	
13	7871329514	GROMMET	1	
14	0601851760	CAP	1	OB-13
15	0010108020	HEX. HEAD BOLT	4	
	0040008000	SPRING WASHER	4	

GA-6HZ—CONTROL BOX ASSY.

CONTROL BOX ASSY.

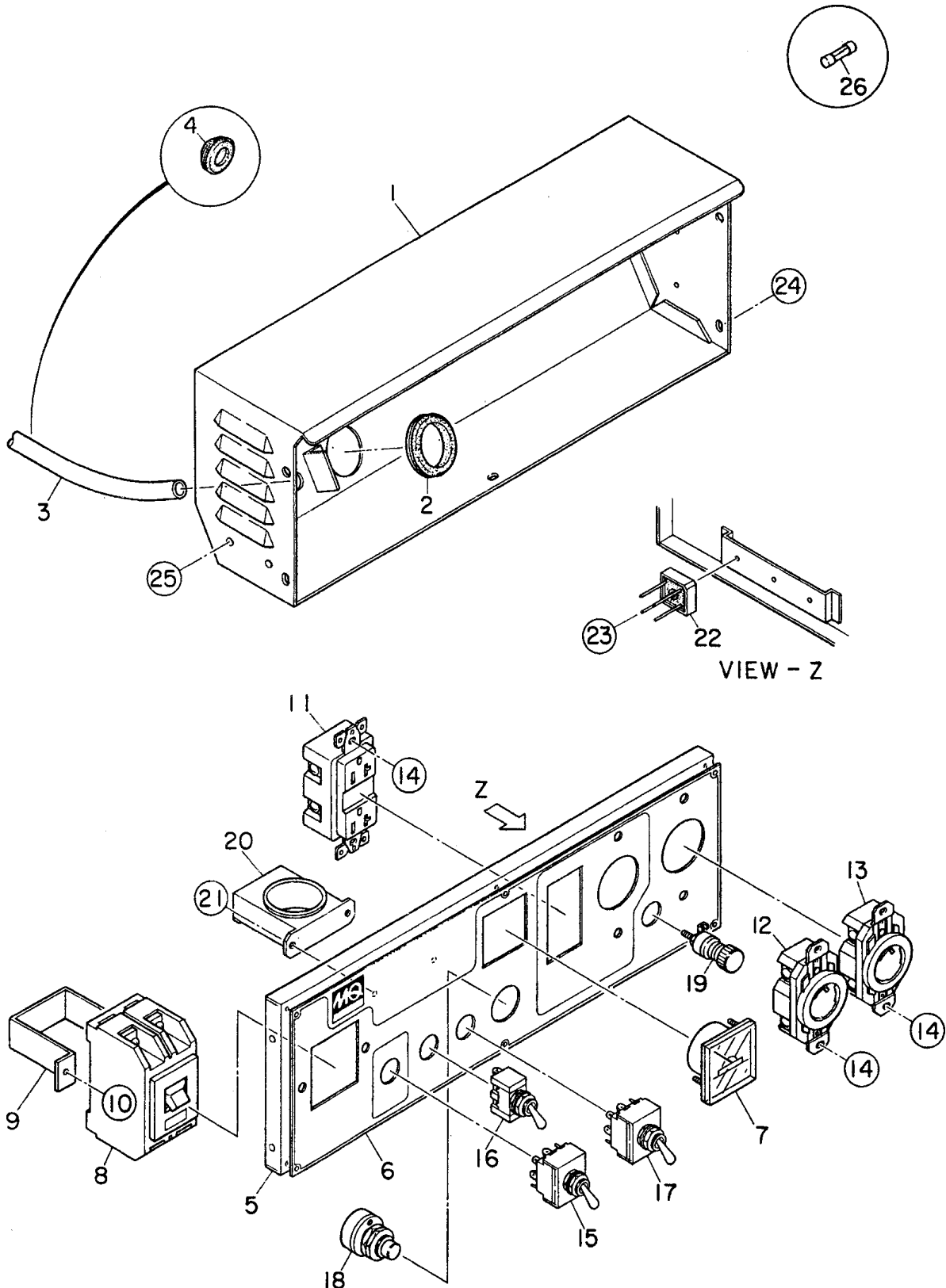

GA-6HZ— CONTROL BOX ASSY.

CONTROL BOX ASSY.

<u>NO</u>	<u>PART NO</u>	<u>PART NAME</u>	<u>QTY.</u>	<u>REMARKS</u>
1	7901810203	CONTROL BOX	1	UP TO S/N.5125596
	7901810213	CONTROL BOX	1	FROM S/N.5125597
2	0601850102	GROMMET	1	
3	0601823204	HOSE	1	
4	7901850004	GROMMET	1	
5	7901820103	CONTROL PANEL	1	UP TO S/N.5125596
	7901820113	CONTROL PANEL	1	FROM S/N.5125597
6	7900501712	NAMEPLATE	1	N-5615B
7	0601800258	AC VOLTMETER 0~120V, 0~240	1	
8	0601804819	CIRCUIT BREAKER, 21A	1	
9	4341817004	BRACKET, CIRCUIT BREAKER	1	
10	0027104010	MACHINE SCREW	2	
11	0601812597	RECEPTACLE,5-20R (GFCI)	2	
12	0601811035	RECEPTACLE, L5-30R, 125V, 30A	1	
13	0601811032	RECEPTACLE,L6-20R, 250V, 20A	1	
14	0027104010	MACHINE SCREW	6	
	0207004000	HEX. NUT	6	
15	0601830737	FULL POWER SWITCH	1	
16	0601830727	IDLE CONTROL SWITCH	1	
17	0601830737	OPERATION SWITCH	1	
18	0602100102	STARTER SWITCH	1	
19	0601815109	GROUND TERMINAL	1	
20	0601823853	SLOW DOWN UNIT	1	
21	0027104010	MACHINE SCREW	2	
22	0601823204	RECTIFIER, S5VB60	3	
23	0027103020	MACHINE SCREW	3	
24	0017105016	HEX. HEAD BOLT	5	
25	0017106016	HEX. HEAD BOLT	4	
26	0601802137	FUSE, 10A	1	

GA-6HZ— PIPE FRAME ASSY.

PIPE FRAME ASSY.

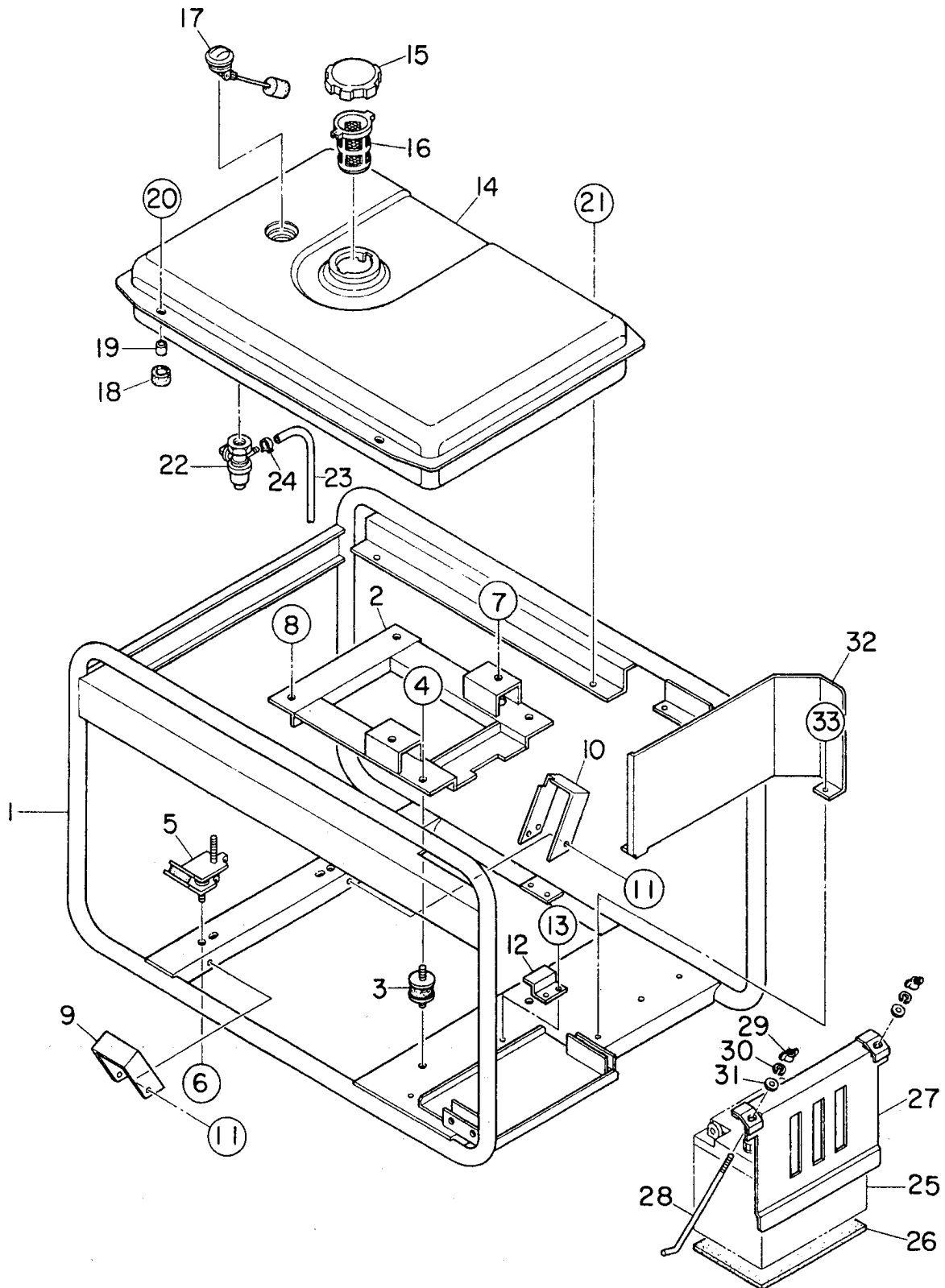

PIPE FRAME ASSY.

<u>NO</u>	<u>PART NO</u>	<u>PART NAME</u>	<u>QTY.</u>	<u>REMARKS</u>
1	7905413102	PIPE FRAME	1	TO S/N 5125596
	7905413112	PIPE FRAME	1	FROM S/N 5125597
2	7905443003	BASE	1	
3	3015419604	RUBBER SUSPENSION	2	
4	0207008000	HEX NUT	4	
5	1725419214	RUBBER SUSPENSION	2	
6	0207008000	HEX NUT	4	
7	0017108030	HEX. HEAD BOLT	2	
8	0017108040	HEX. HEAD BOLT	2	
	0207008000	HEX, NUT	2	
9	7915455103	COVER	1	
10	7855455003	COVER	1	
11	0017106016	HEX. HEAD BOLT	6	
12	7905456104	STOPPER	1	
13	0017106016	HEX. HEAD BOLT	2	
14	7905512002	FUEL TANK	1	
15	0810106004	CAP, FUEL TANK	1	
16	0810107103	FUEL FILTER	1	
17	0602125031	FUEL GAGE	1	
18	7855525514	RUBBER CUSHION	2	
19	7855525604	COLLAR	2	
20	0017108030	HEX. HEAD BOLT	2	
21	0017108020	HEX. HEAD BOLT	2	
22	0605511087	FUEL COCK	1	HONDA 16950-ZB4-015
23	0605513140	HOSE	1	HONDA 950001-4519040
24	0605515096	HOSE BAND	2	
25		BATTERY	1	
26	1702202104	BATTERY SHEET	1	
27	7905458103	BATTERY BAND	1	
28	0805082204	BATTERY BOLT	2	
29	0037806000	WING NUT	2	
30	0040006000	SPRING WASHER	2	
31	0041206000	PLAIN WASHER	2	

GA-6HZ— MUFFLER ASSY.

MUFFLER ASSY.

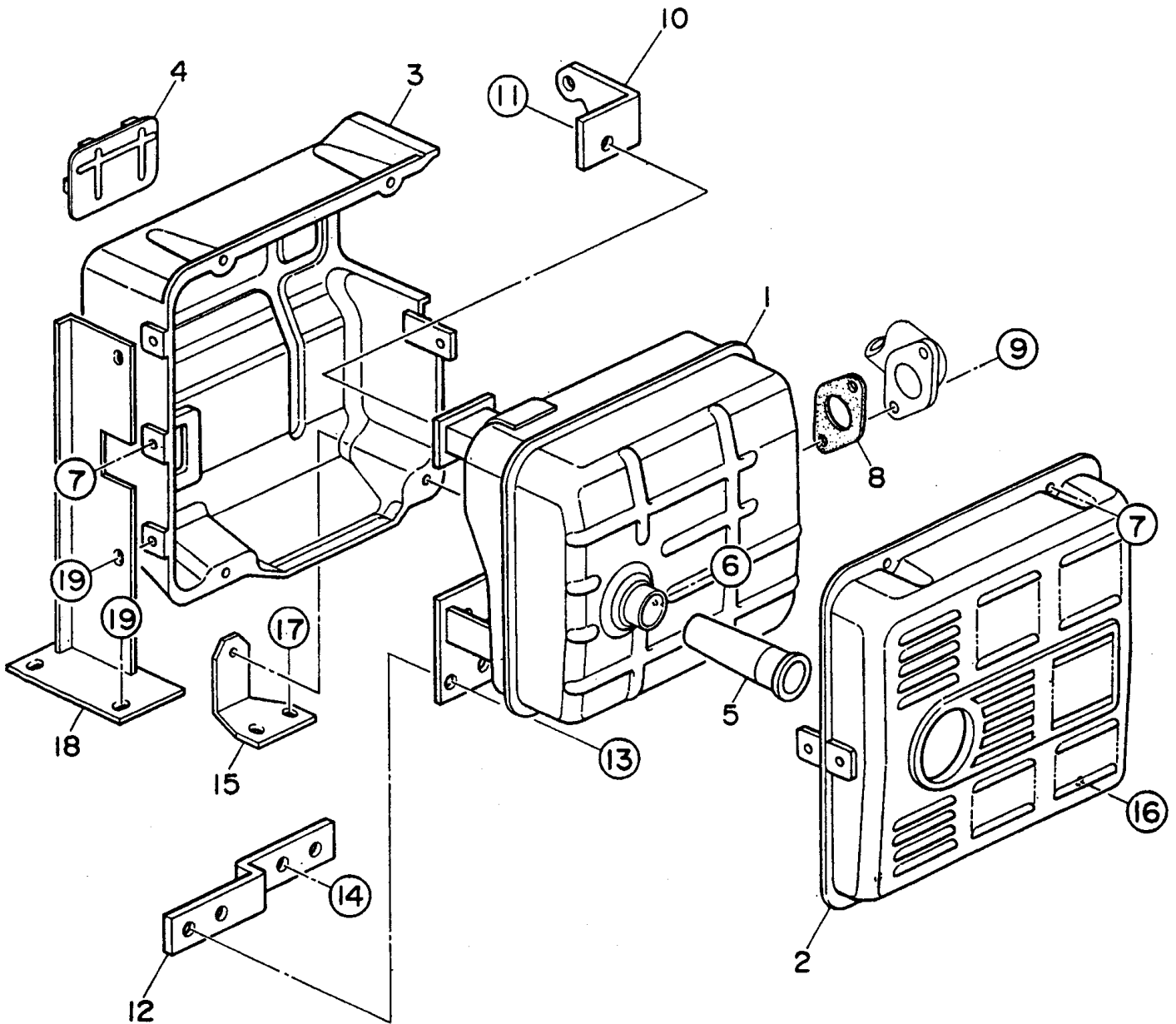

MUFFLER ASSY.

<u>NO</u>	<u>PART NO</u>	<u>PART NAME</u>	<u>QTY.</u>	<u>REMARKS</u>
1	7912310003	MUFFLER	1	
2	0602302001	PROCTER, MUFFLER	1	HONDA 18320-ZC2-000
3	0602302002	PROCTER, MUFFLER	1	HONDA 18325-ZB4-000
4	0602302003	SEAL	2	HONDA 18329-ZB4-000
5	0602313060	ARRESTOR, SPARK	1	HONDA 18335-ZB4-630
6	0602322060	TAPPING SCREW	1	HONDA 90183-671-003
7	0017106012	HEX. HEAD BOLT	5	
8	0602320175	GASKET	1	HONDA 18333-ZB4-800
9	0602322061	HEX. HEAD BOLT	2	HONDA 95700-08020-00
10	7905461004	BRACKET	1	
11	001708020	HEX. HEAD BOLT	1	
12	7905460004	BRACKET	1	
13	0017108025	HEX. HEAD BOLT	2	
	0207008000	HEX, NUT	2	
14	0017108020	HEX. HEAD BOLT	2	
15	7905469004	BRACKET	1	
16	0017106020	HEX. HEAD BOLT	1	
17	0017106012	HEX. HEAD BOLT	2	
18	7905468004	BRACKET	1	UP TO S/N 5125596
	7905468014	BRACKET	1	FROM S/N 5125597
19	001706020	HEX. HEAD BOLT	4	

NAMEPLATE AND DECALS

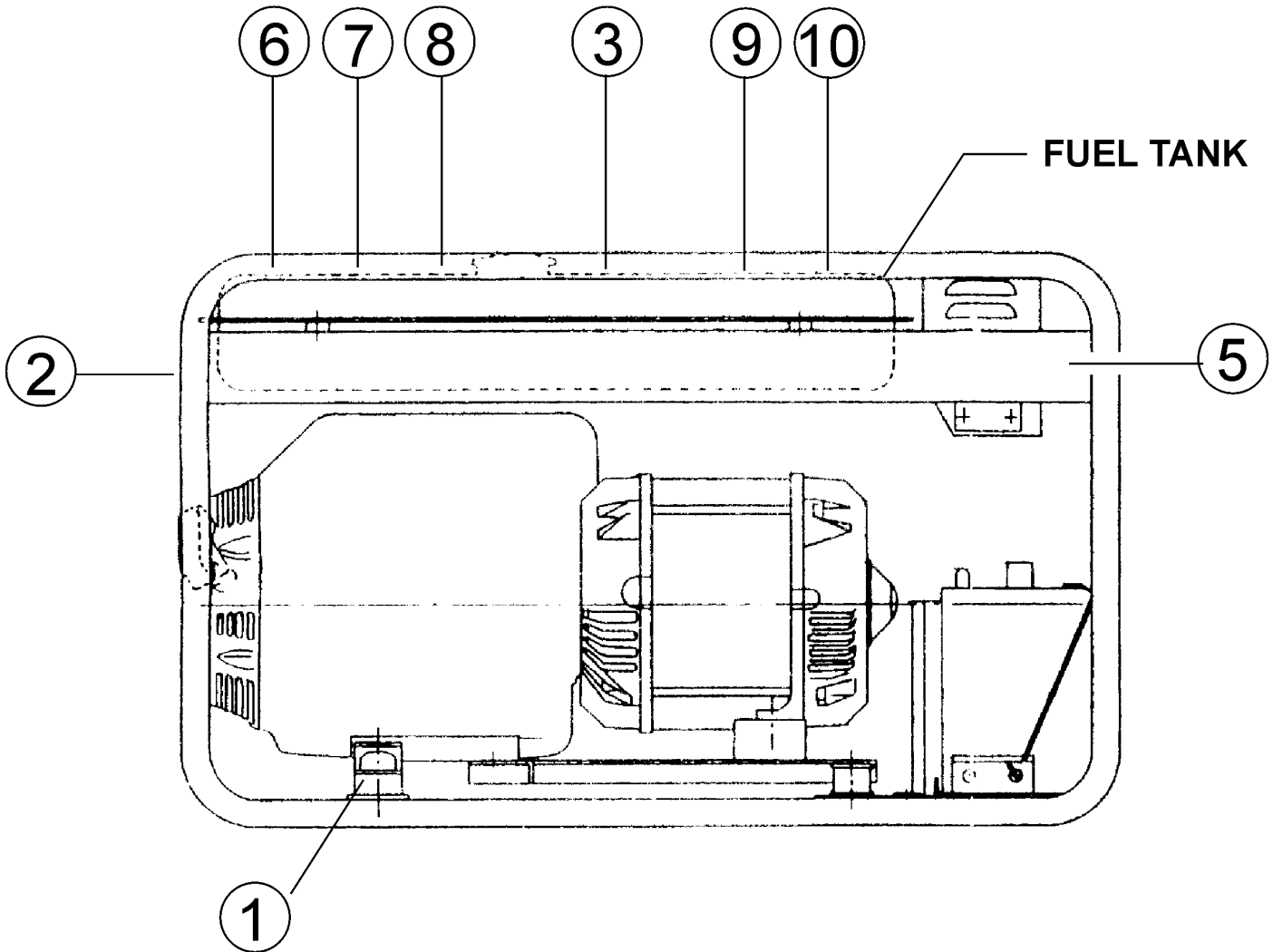

GA-6HZ — NAMEPLATE AND DECALS

NAMEPLATE AND DECALS

NO	PART NO	PART NAME	QTY.	REMARKS
1	0800628504	DECAL : GROUND	1	S-1123
2	1980680004	DECAL : FUEL COCK	1	S-3704
3	7900638204	DECAL : OPERATING INSTRUCTIONS	1	S-4605
4	7900501712	DECAL : MQ GA-6HZ	1	N-5615B
5	7900631302	DECAL : MQ 6000	1	S-5015
6	0820610804	DECAL : CAUTION	1	S-3311
7	0820610404	DECAL : WARNING	1	S-3627
8	7900636004	DECAL : OPERATE AT 3600 RPM ONLY	1	S-4461
9	8700611804	DECAL : WARNING	1	S-4984
10	8700611904	DECAL : DANGER	1	S-4985

SEE ADDITIONAL DECAL ILLUSTRATIONS ON PAGE 7.

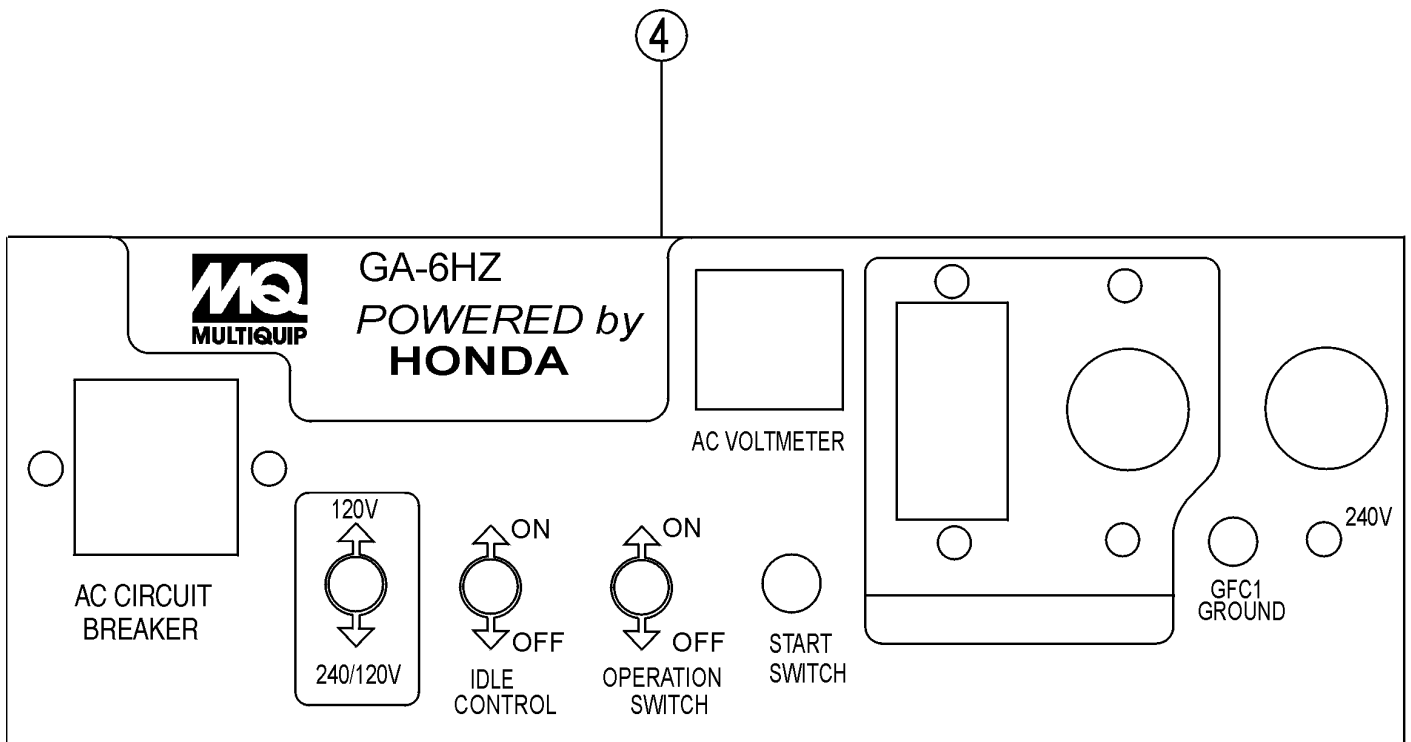

HONDA GX340K1 ENGINE — CYLINDER HEAD

CYLINDER HEAD ASSY.

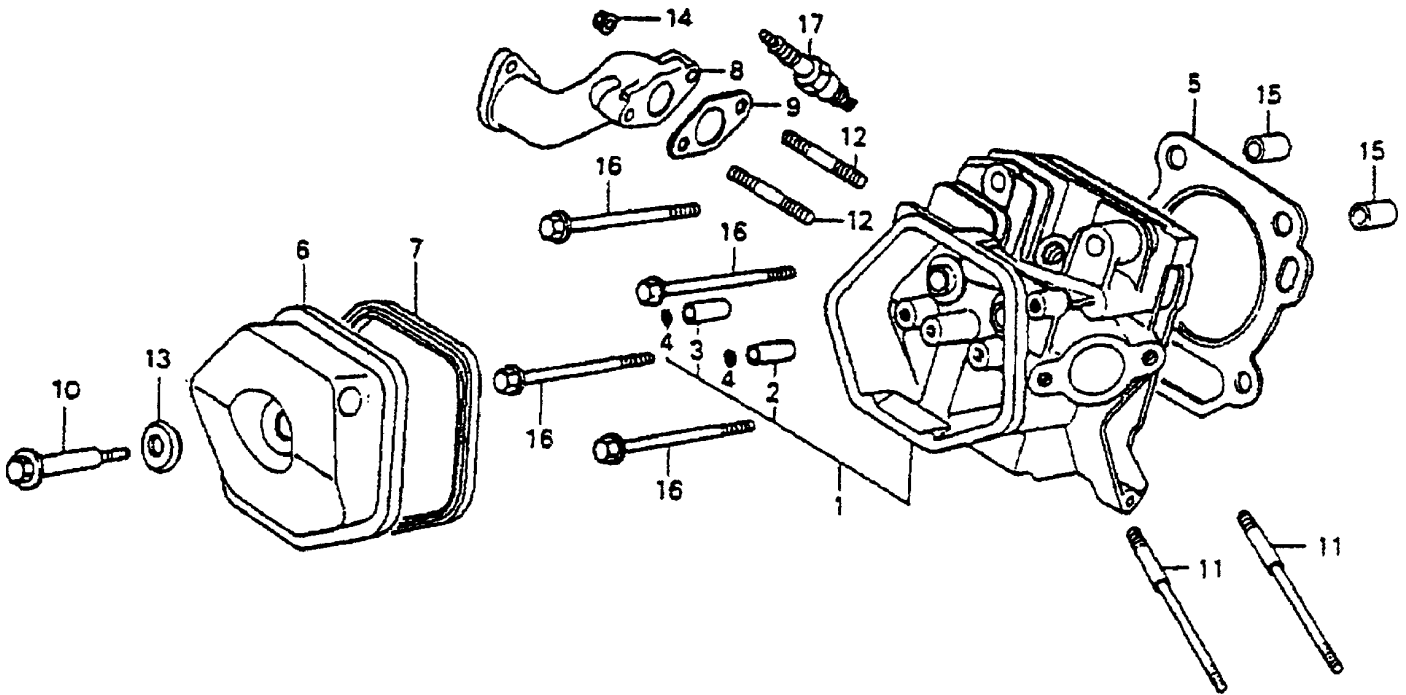

HONDA GX340K1 ENGINE — CYLINDER HEAD

CYLINDER HEAD ASSY.

<u>NO</u>	<u>PART NO</u>	<u>PART NAME</u>	<u>QTY.</u>	<u>REMARKS</u>
1	122AOZF6W00	HEAD COMP., CYLINDER	1	INCLUDES ITEM W/*
2*	12204ZE2325	GUIDE, IN. VALVE (OVER SIZE)	1	
3*	12205ZE2315	GUIDE, EX. VALVE (OVER SIZE)	1	
4*	12216ZE2300	CLIP, VALVE GUIDE	2	
5	12251ZE3W00	GASKET, CYLINDER HEAD	1	
6	12310ZE2010	COVER COMP., HEAD	1	
7	12391ZE2010	PACKING, HEAD COVER	1	
8	18330ZE3700	PIPE, EX.	1	
9	18333ZE3800	GASKET, EX. PIPE	1	
10	90014ZE2000	BOLT, HEAD COVER	1	
11	90042ZE3700	BOLT, STUD, 8X98	2	
12	90047ZE2000	BOLT, STUD, 8X47	2	
13	90441ZE2010	WASHER COMP., HEAD COVER	1	
14	9405008000	NUT, FLANGE, 8MM	2	
15	9430112200	PIN, DOWEL, 12X20	2	
16	957251008000	BOLT, FLANGE, 10X80	4	
17	9807955846	PLUG, SPARK (BPR5ES NGK)	1	
	9807955855	PLUG, SPARK (W16EPRU ND)	1	

HONDA GX340K1 ENGINE — RECOIL STARTER

RECOIL STARTER ASSY.

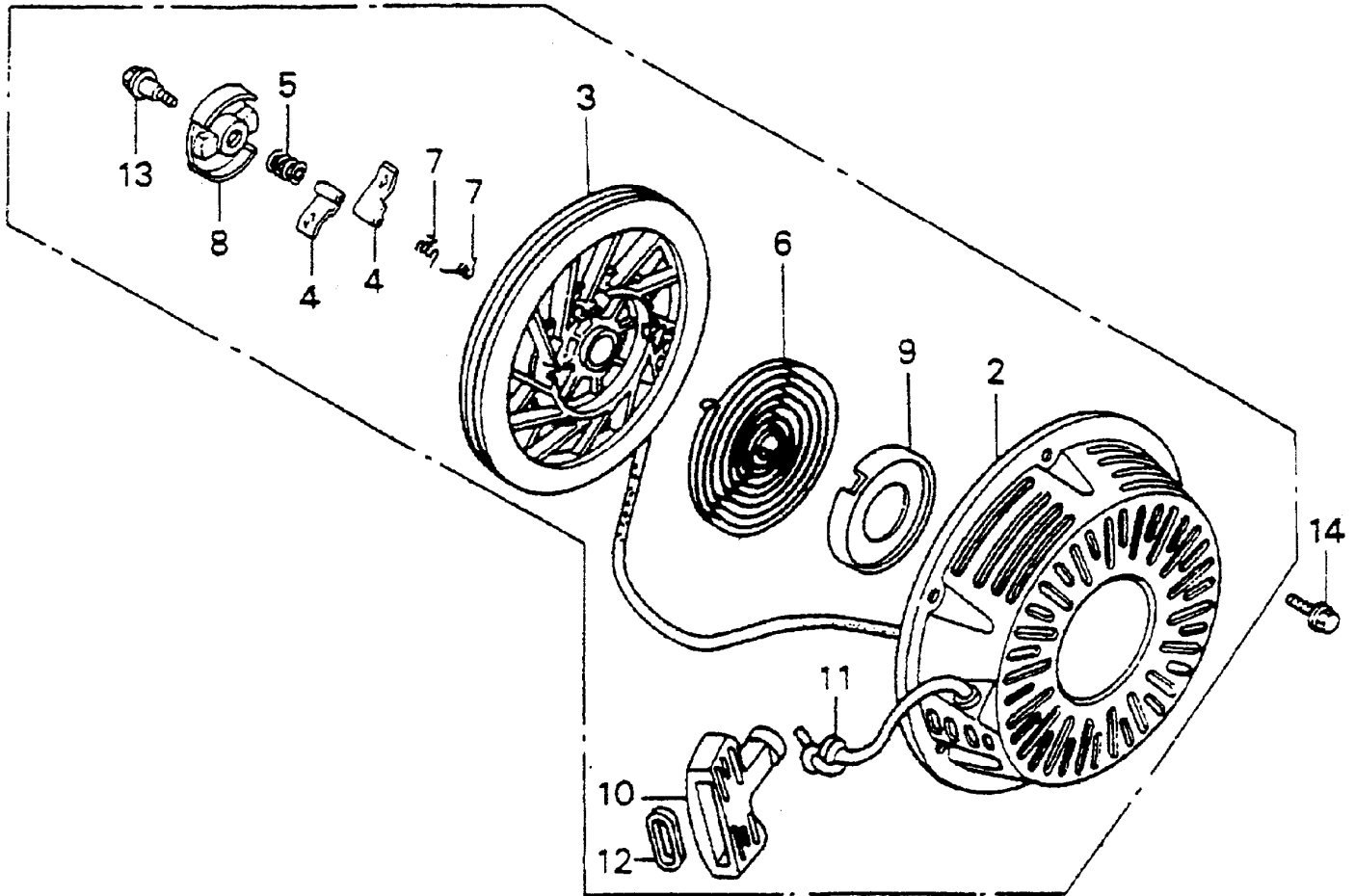

HONDA GX340K1 ENGINE — RECOIL STARTER

RECOIL STARTER ASSY.

<u>NO</u>	<u>PART NO</u>	<u>PART NAME</u>	<u>QTY.</u>	<u>REMARKS</u>
1	28400ZE3W01ZB	STARTER ASSY, RECOIL	1	INCLUDES ITEMS W/*
2*	28410ZE3W01ZB	CASE COMP., RECOIL STARTER	1	
3*	28421ZE3W01	PULLEY, RECOIL STARTER	1	
4*	28422ZE2W01	RATCHET, STARTER	2	
5*	28441ZE2W01	SPRING, FRICTION	1	
6*	28442ZE2W01	SPRING, STARTER RETURN	1	
7*	28443ZE2W01	SPRING, RATCHET	2	
8*	28444ZE2W01	RETAINER, SPRING	1	
9*	28445ZE2W01	HOLDER, SPRING	1	
10*	28461ZE2W01	GRIP, STARTER	1	
11*	28462ZE3W01	ROPE, RECOIL STARTER	1	
12*	28469ZE2W01	GRID REINFORCEMENT	1	
13*	90004ZE2W01	SCREW, CENTER	1	
14	957010600800	BOLT, FLANGE, 6X8	3	

HONDA GX340K1 ENGINE — FAN COVER

FAN COVER ASSY.

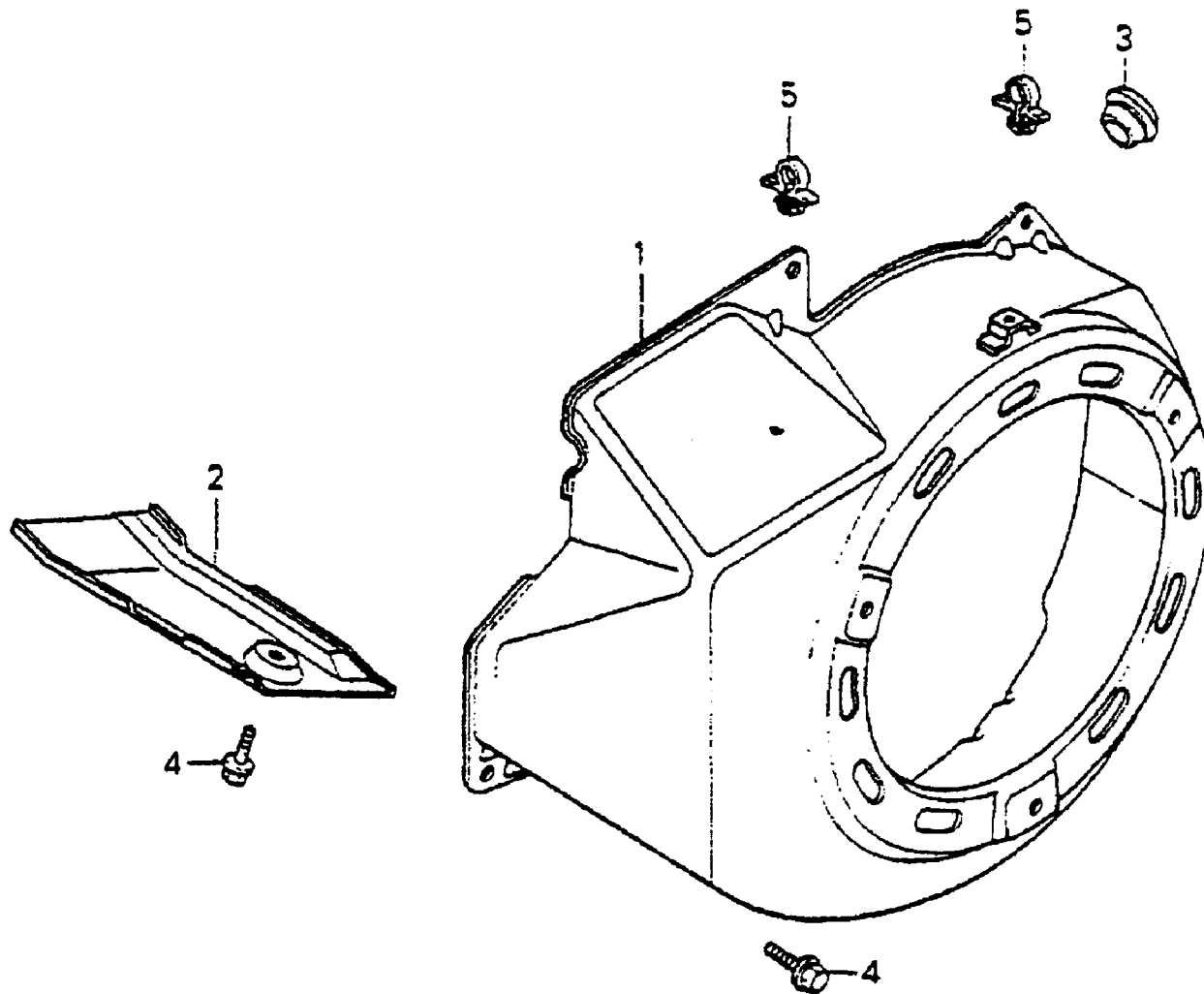

HONDA GX340K1 ENGINE — FAN COVER

FAN COVER ASSY.

<u>NO</u>	<u>PART NO</u>	<u>PART NAME</u>	<u>QTY.</u>	<u>REMARKS</u>
1	19610ZE3700ZB	COVER COMP., FAN	1	
2	19631ZE3W00	SHROUD	1	
3	81329567020	GROMMET, DRAIN HOLE	1	
4	90013883000	BOLT, FLANGE, 6X12	6	
5	90654SA4003	CLIP	2	

HONDA GX340K1 ENGINE — CAMSHAFT/VALVES

CAMSHAFT/VALVES ASSY.

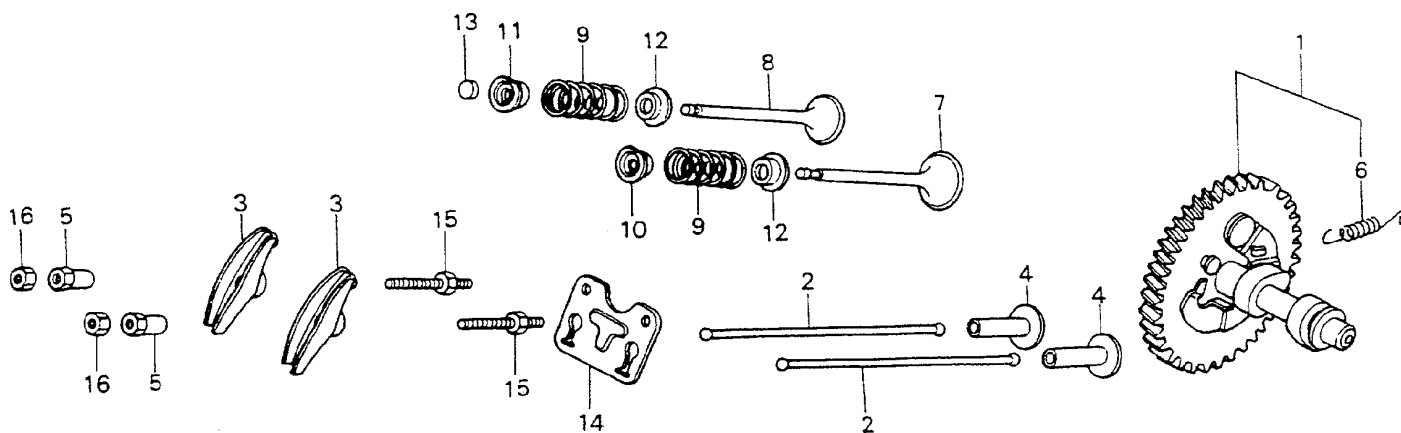

HONDA GX340K1 ENGINE — CAMSHAFT/VALVES

CAMSHAFT/VALVES ASSY.

<u>NO</u>	<u>PART NO</u>	<u>PART NAME</u>	<u>QTY.</u>	<u>REMARKS</u>
1	14100ZE3010	CAMSHAFT ASSY.	1	INCLUDES ITEMS/W*
2	14410ZE3013	ROD, PUSH	2	
3	14431ZE2000	ARM, VALVE ROCKER	2	
4	14441ZE2000	LIFTER, VALVE	2	
5	14451ZE1003	PIVOT, ROCKER ARM	2	
6*	14568ZE1000	SPRING, WEIGHT RETURN	1	
7	14711ZE3000	VALVE, IN	1	
8	14721ZE3000	VALVE, EX.	1	
9	14751ZE2003	SPRING, VALVE	2	
10	14771ZE2000	RETAINER, IN. VALVE SPRING	1	
11	14773ZE2000	RETAINER, EX. VALVE SPRING	1	
12	14775ZE2010	SEAT, VALVE SPRING	2	
13	14781ZE2000	ROTATOR, VALVE	1	
14	14791ZE2010	PLATE, PUSH ROD GUIDE	1	
15	90012ZE0010	BOLT, PIVOT	2	
15	90206ZE1000	NUT, PIVOT ADJUSTING	2	

HONDA GX340K1 ENGINE — PISTON/RINGS

PISTON/RINGS ASSY.

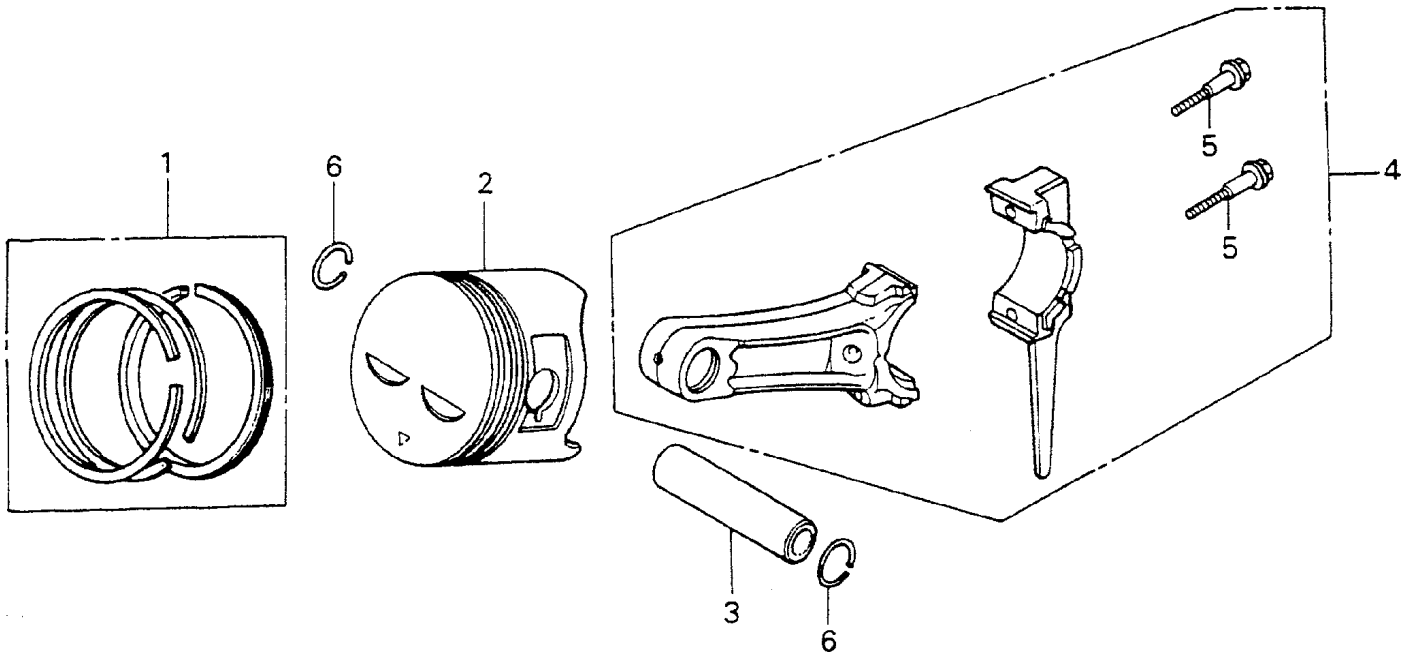

HONDA GX340K1 ENGINE — PISTON/RINGS

PISTON/RINGS ASSY.

<u>NO</u>	<u>PART NO</u>	<u>PART NAME</u>	<u>QTY.</u>	<u>REMARKS</u>
1	13010ZE3003	RING SET, PISTON (STD)	1	
	13011ZE3003	RING SET, PISTON (0.25)	1	
	13012ZE3003	RING SET, PISTON (0.50)	1	
	13013ZE3003	RING SET, PISTON (0.75)	1	
2	13101ZE3W00	PISTON (STD)	1	
	13102ZE3W00	PISTON (0.25)	1	
	13103ZE3W00	PISTON (0.50)	1	
	13104ZE3W00	PISTON (0.75)	1	
3	13111ZF6000	PIN, PISTON	1	
4	13200ZE3010	ROD ASSY., CONNECTING	1	INCLUDES ITEM W/*
5*	90001ZE8000	BOLT, CONNECTING ROD	2	
6	90601ZE3000	CLIP, PISTON PIN, 18MM	2	

HONDA GX340K1 ENGINE — AIR CLEANER

AIR CLEANER ASSY.

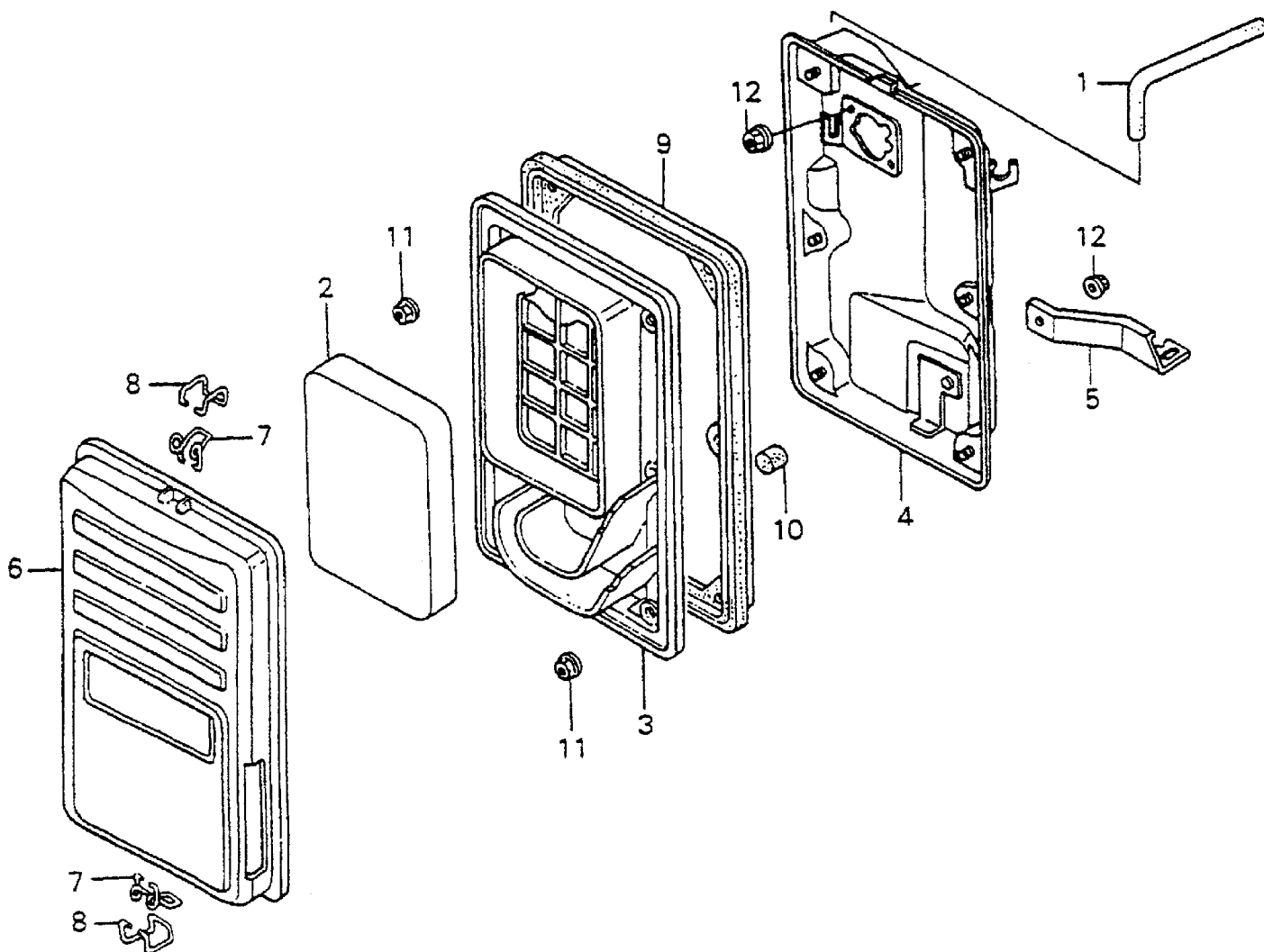

HONDA GX340K1 ENGINE — AIR CLEANER

AIR CLEANER ASSY.

<u>NO</u>	<u>PART NO</u>	<u>PART NAME</u>	<u>QTY.</u>	<u>REMARKS</u>
1	15721ZB4000	TUBE BREATHER	1	
2	17211899000	ELEMENT, AIR CLEANER	1	
3	17212ZB4003	SEPARATOR, AIR CLEANER	1	
4	17220ZB4003	CASE COMP., AIR CLEANER	1	
5	17222ZC2000	STAY, AIR CLEANER	1	
6	17231899000	COVER COMP., AIR CLEANER	1	
7	17235899000	CLIP A, AIR CLEANER WIRE	2	
8	17236899000	CLIP B, AIR CLEANER WIRE	2	
9	17252899000	SEAL, AIR CLEANER	1	
10	17367413690	FILTER, DRAIN TUBE	1	
11	9405005000	NUT, FLANGE, 5 MM	6	
12	9405006000	NUT, FLANGE, 6 MM	3	

HONDA GX340K1 ENGINE — CYLINDER BARREL

CYLINDER BARREL ASSY. (RECOIL STARTER)

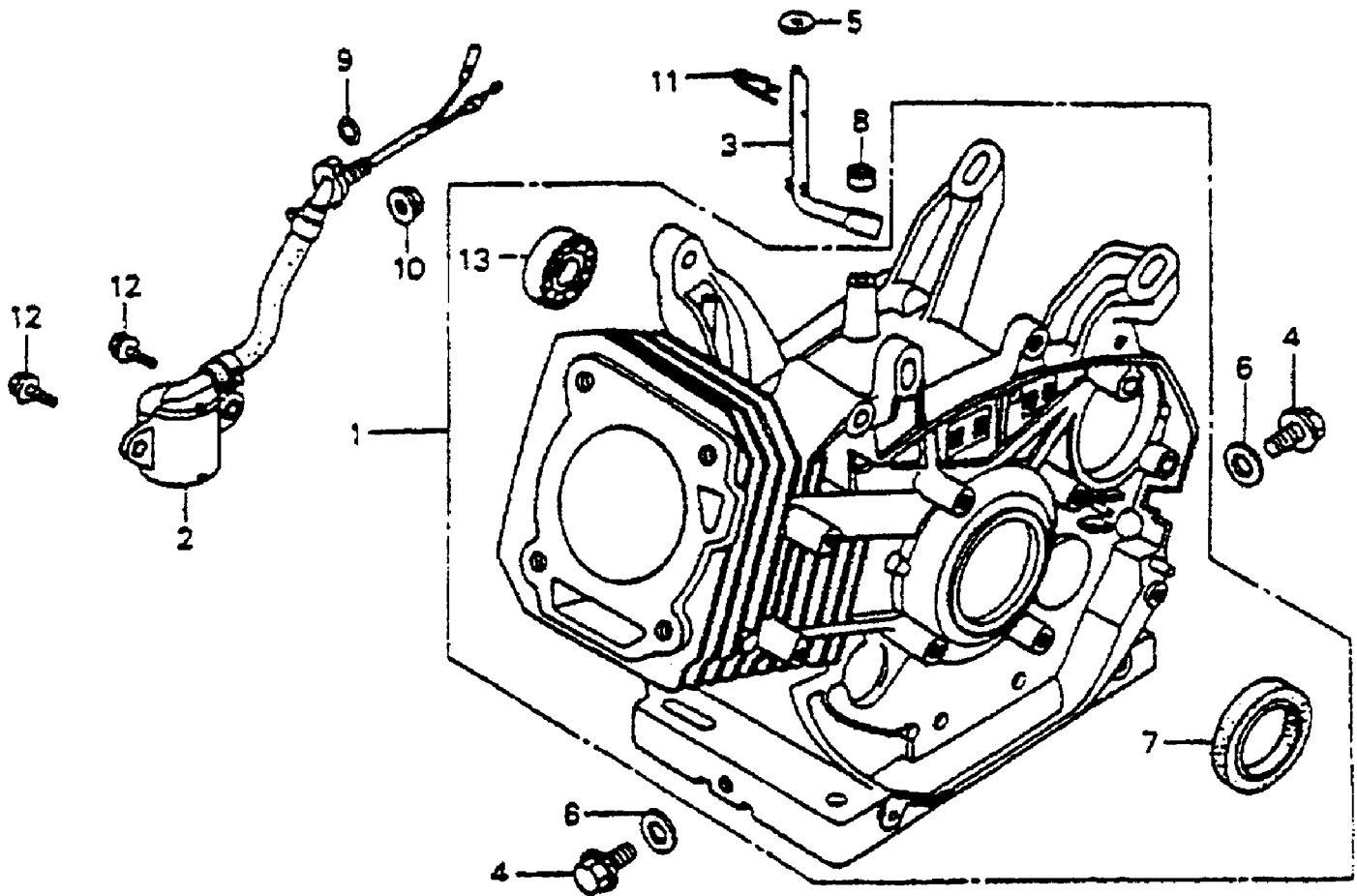

HONDA GX340K1 ENGINE — CYLINDER BARREL

CYLINDER BARREL ASSY. (RECOIL STARTER)

<u>NO</u>	<u>PART NO</u>	<u>PART NAME</u>	<u>QTY.</u>	<u>REMARKS</u>
1	12000ZE3816	BARREL ASSY., CYLINDER	1	
2	15510ZE2043	SWITCH ASSY., OIL LEVEL	1	
3	16541ZE3000	SHAFT, GOVERNOR ARM	1	
4	90131883000	BOLT, DRAIN PLUG	2	
5	90446KE1000	WASHER, 8.2X17X0.8	1	
6	9410912000	WASHER, DRAIN PLUG	2	
7	91201ZE3004	OIL SEAL	1	
8	91203952771	OIL SEAL	1	
9	91353671004	ORING, 14 MM	1	
10	9405010000	NUT, FLANGE, 10 MM	1	
11	9425108000	PIN, LOCK, 8 MM	1	
12	957010601200	BOLT, FLANGE, 6X12	2	
13	961006202000	BEARING, RADIAL BALL 6202	1	

HONDA GX340K1 ENGINE — CYLINDER BARREL

CYLINDER BARREL ASSY. (ELECTRIC START)

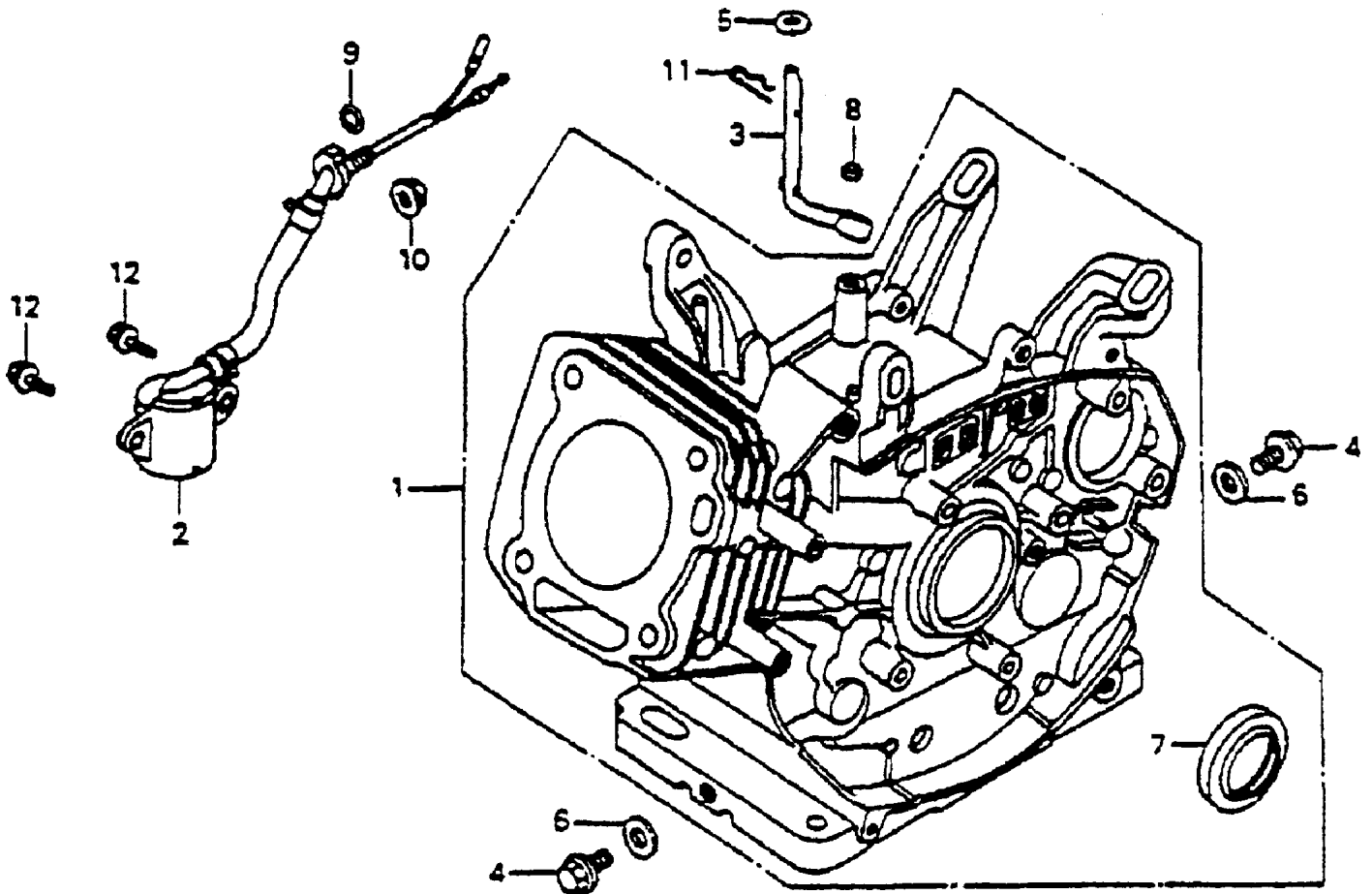

HONDA GX340K1 ENGINE — CYLINDER BARREL

CYLINDER BARREL ASSY. (ELECTRIC START)

<u>NO</u>	<u>PART NO</u>	<u>PART NAME</u>	<u>QTY.</u>	<u>REMARKS</u>
1	12000ZE3826	BARREL ASSY., CYLINDER	1	
2	15510ZE2043	SWITCH ASSY., OIL LEVEL	1	
3	16541ZE3000	SHAFT, GOVERNOR ARM	1	
4	90131883000	BOLT, DRAIN PLUG	2	
5	90446KE1000	WASHER, 8.2X17X0.8	1	
6	9410912000	WASHER, DRAIN PLUG	2	
7	91201ZE300	OIL SEAL	1	
8	91203952771	OIL SEAL	1	
9	91353671004	ORING, 14 MM	1	
10	9405010000	NUT, FLANGE, 10 MM	1	
11	9425108000	PIN, LOCK, 8 MM	1	
12	957010601200	BOLT, FLANGE, 6X12	2	
13	961006202000	BEARING, RADIAL BALL 6202	1	

HONDA GX340K1 ENGINE — CRANKCASE COVER/GOVERNOR

CRANKCASE COVER/GOVERNOR ASSY.

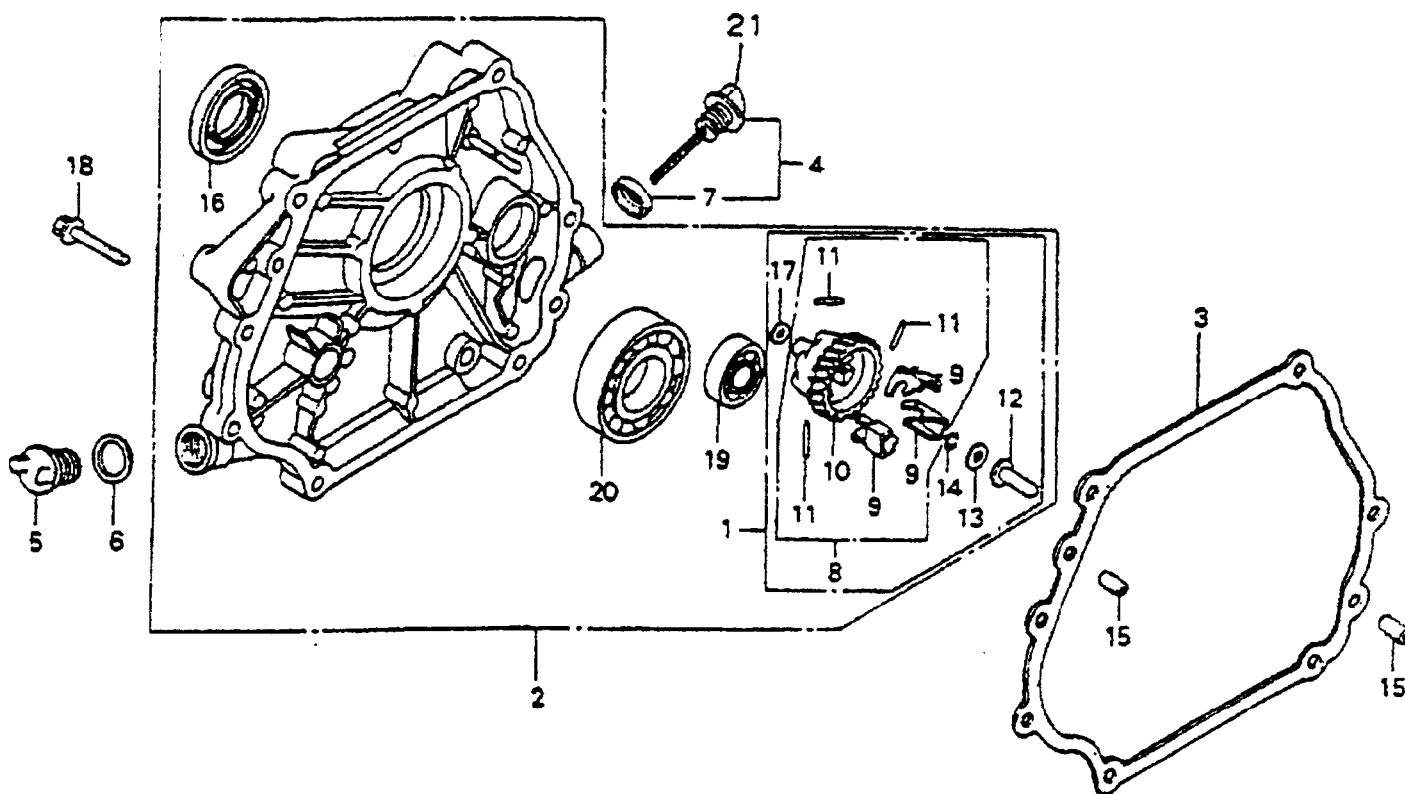

HONDA GX340K1 ENGINE — CRANKCASE COVER/GOVERNOR

CRANKCASE COVER/GOVERNOR ASSY.

<u>NO</u>	<u>PART NO</u>	<u>PART NAME</u>	<u>QTY.</u>	<u>REMARKS</u>
1+	06165ZE3000	GOVERNOR KIT	1	INCLUDES ITEM W/*
2	11300ZE3020	COVER ASSY., CRANKCASE	1	INCLUDES ITEM W/+
3	11381ZE3800	PACKING, CASE COVER	1	
4	15600735700	CAP ASSY., OIL FILLER	1	INCLUDES ITEM W/#
5	15621896010	PACKING, OIL FILLER CAP	1	
6	15625ZE1000	PACKING, OIL FILLER CAP	1	
7#	16510ZE3000	GOVERNOR ASSY.	1	
8*+	16511ZE8000	WEIGHT, GOVERNOR	3	
9*+	16512ZE3000	HOLDER, GOVERNOR WEIGHT	1	
10*+	16513ZE2000	PIN, GOVERNOR WEIGHT	3	
11*+	16531ZE2000	SLIDER, GOVERNOR	1	
12*+	16520ZG4910	CAP, OIL FILLER	1	
13*+	90473147000	WASHER, 6X16	1	
14*+	90602ZE1000	CLIP, GOVERNOR HOLDER	1	
15	91201ZE3004	OIL SEAL, 35X52X8	1	
16+	9410106800	WASHER, PLAIN, 6 MM	1	
17*	90701HC4000	PIN, DOWEL, 8X12	2	
18	959000804000	BOLT, FLANGE, 8X40	7	
19+	961006202000	BEARING, RADIAL BALL 6202	1	
20+	961006207000	BEARING, RADIAL BALL 6207	1	
21#	15620735700	CAP, OIL FILLER	1	

HONDA GX340K1 ENGINE — FLYWHEEL/FAN ASSY.

FLYWHEEL/FAN ASSY.

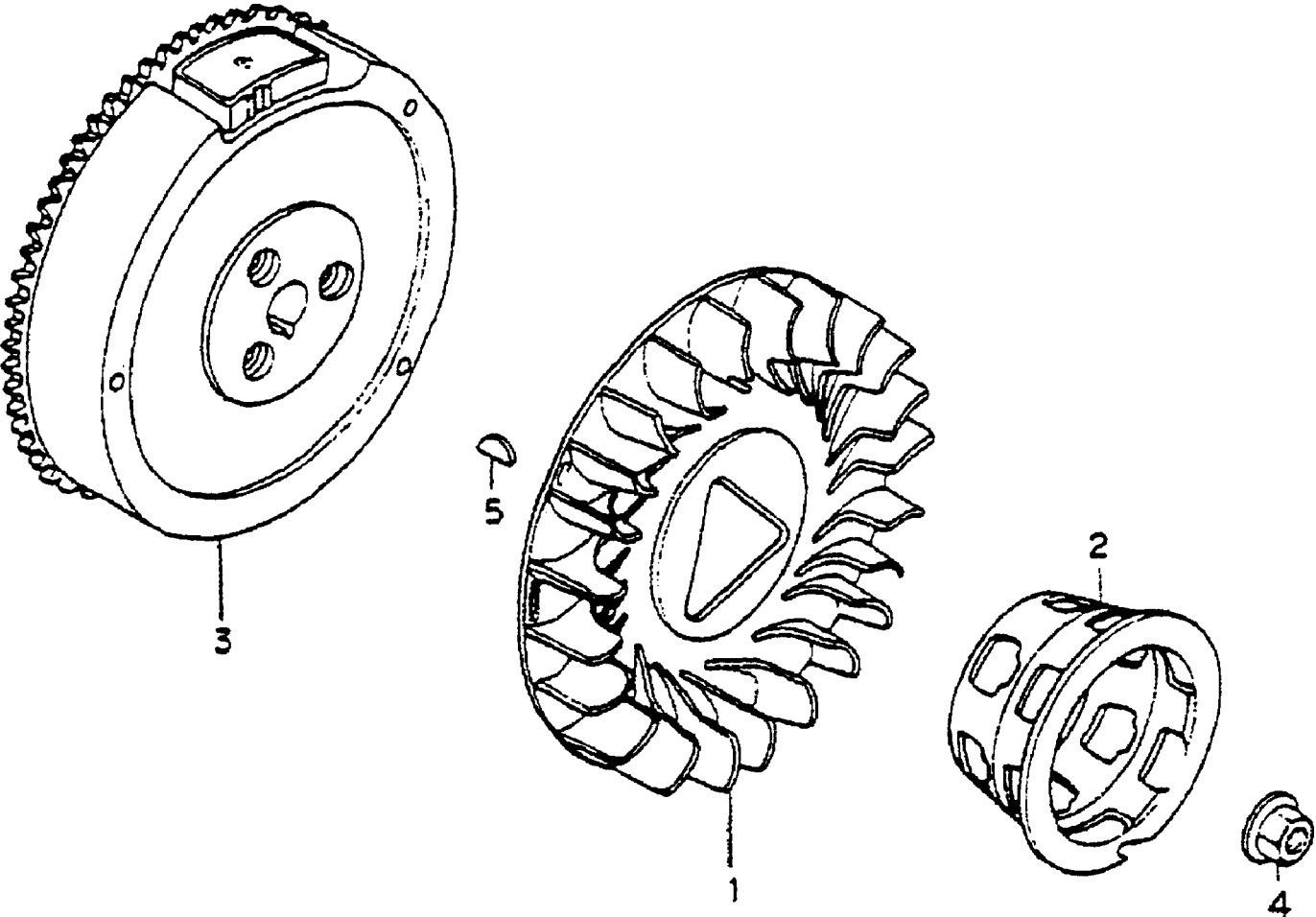

HONDA GX340K1 ENGINE — FLYWHEEL/FAN ASSY.

FLYWHEEL/FAN ASSY.

<u>NO</u>	<u>PART NO</u>	<u>PART NAME</u>	<u>QTY.</u>	<u>REMARKS</u>
1	19511ZE3000	FAN, COOLING	1	
2	28451ZE3W01	PULLEY, STARTER	1	
3	31100ZE3721	FLYWHEEL COMP.	1	
4	90201ZE3790	NUT, SPECIAL, 16 MM	1	
5	90741ZE2000	KEY, SPECIAL WOODRUFF	1	

HONDA GX340K1 ENGINE — COIL ASSY.

COIL ASSY.

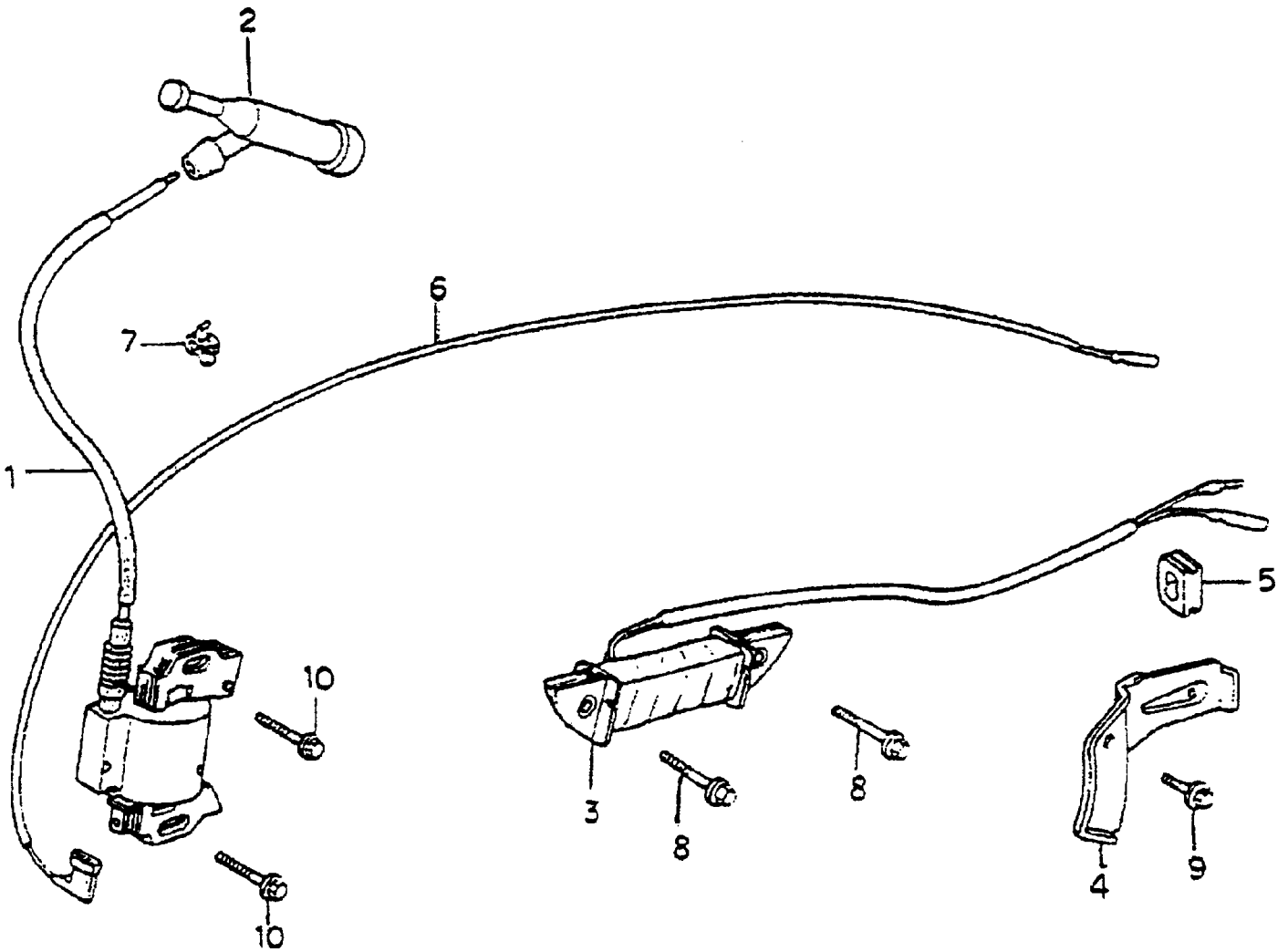

HONDA GX340K1 ENGINE — COIL ASSY.

COIL ASSY.

<u>NO</u>	<u>PART NO</u>	<u>PART NAME</u>	<u>QTY.</u>	<u>REMARKS</u>
1	30500ZE2013	COIL ASSY., IGNITION	1	
2	30700ZE1013	CAP ASSY., NOISE SUPPRESSO	1	
3	31510ZE1811	COIL ASSY., LAMP 12V/25W	1	
4	31511ZE3000	CLAMP, WIRE	1	
5	31512ZE2000	GROMMET, CORD	1	
6	36101ZE3800	CORD, STOP SWITCH	1	
7	36103ZE1000	HOLDER, STOP SWITCH CORD	1	
8	90012888000	BOLT, FLANGE, 6X40	4	
9	90013883000	BOLT, FLANGE, 6X12	1	
10	90015883000	BOLT, FLANGE, 6X28	2	

HONDA GX340K1 ENGINE — CRANKSHAFT ASSY.

CRANKSHAFT ASSY.

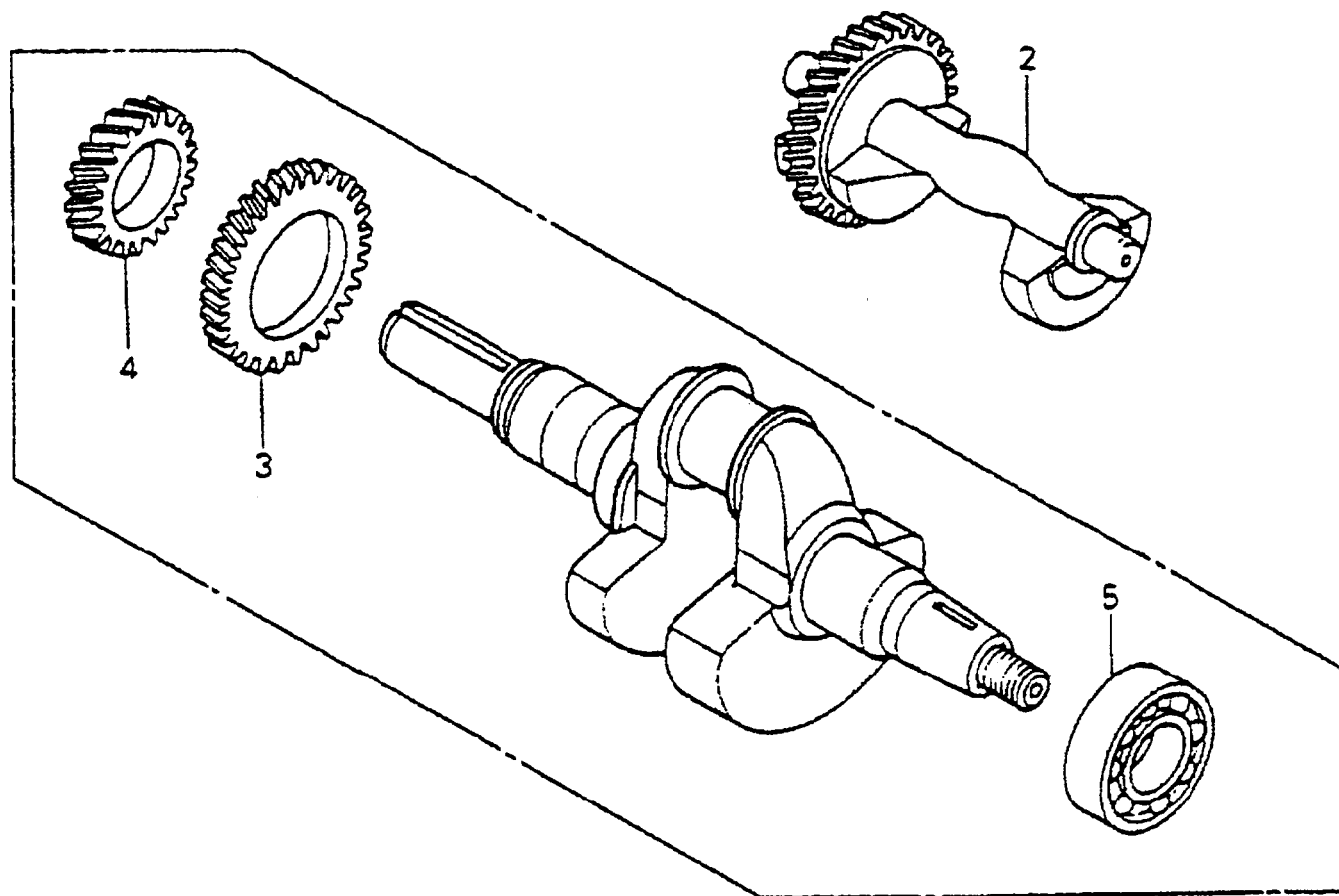

HONDA GX340K1 ENGINE — CRANKSHAFT ASSY.

CRANKSHAFT ASSY.

<u>NO</u>	<u>PART NO</u>	<u>PART NAME</u>	<u>QTY.</u>	<u>REMARKS</u>
1	13310ZE3701	CRANKSHAFT COMP.	1 INCLUDES ITEMS W/*
2	13351ZE3010	WEIGHT, BALANCER	1	
3*	13352ZE3310	GEAR, BALANCER DRIVE	1	
4*	14311ZE3310	GEAR, TIMING	1	
5*	961006207000	BEARING, RADIAL BALL, 6207	1	

HONDA GX340K1 ENGINE — ELECTRIC STARTER ASSY.

ELECTRIC STARTER ASSY.

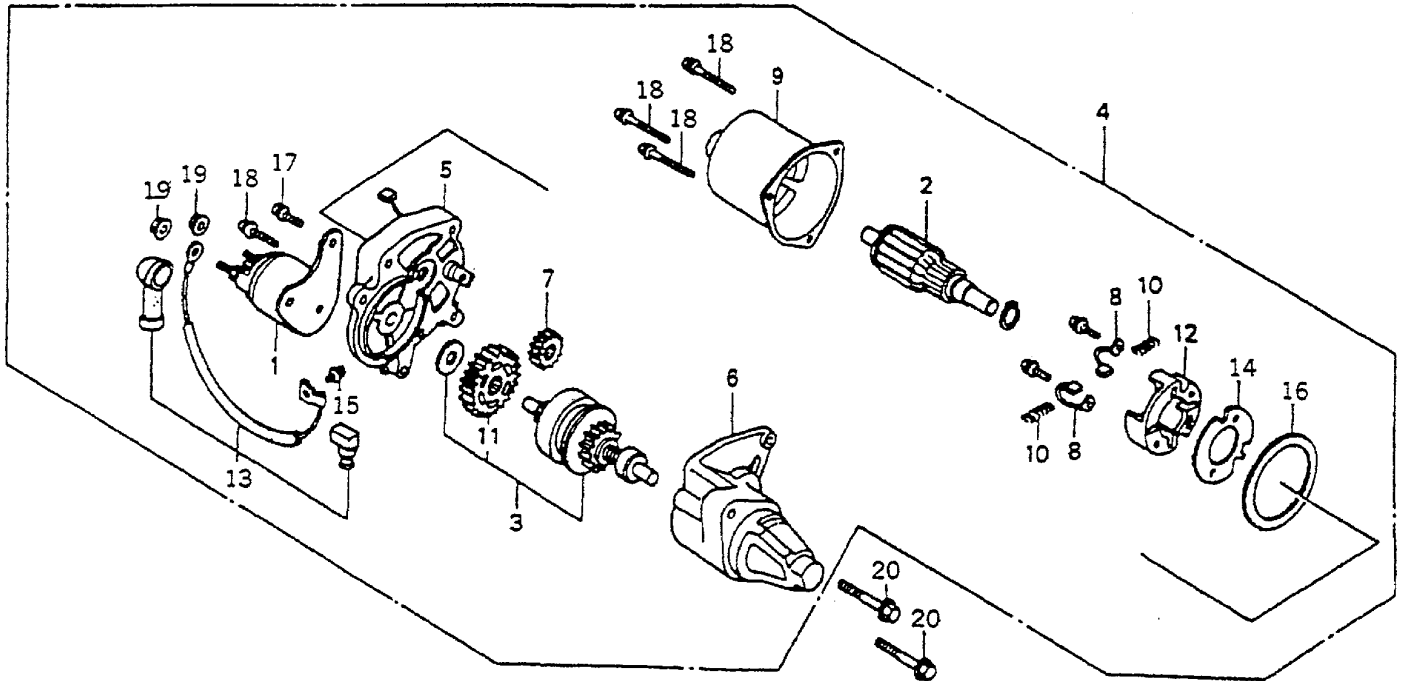

HONDA GX340K1 ENGINE — ELECTRIC STARTER ASSY.

ELECTRIC STARTER ASSY.

<u>NO</u>	<u>PART NO</u>	<u>PART NAME</u>	<u>QTY.</u>	<u>REMARKS</u>
1*	31204ZA0003	CONTACTOR ASSY,	1	
2*	31206ZE3003	ARMATURE COMP	1	
3*	31207ZE3013	CLUTCH COMP, OVER RUNNING	1 INCLUDES ITEMS W/#
4	31201ZE3013	MOTOR UNIT, STARTER	1 INCLUDES ITEMS W/*
5*	31211ZE2003	BRAKET, CENTER	1	
6*	31212ZE3003	BRAKET, FR	1	
7*	31213ZE2003	GEAR, DRIVE DINION	1	
8*	31215ZE2003	BRUSH	2	
9*	31218ZE3003	YOKE COMP	1	
10*	31219ZE2003	SPRING, BRUSH RETURN	4	
11*#	31222ZE3791	GEAR, REDUCTION	1	
12*	31231ZE2003	HOLDER, BRUSH	1	
13*	31232ZE3003	WIRE, WATER COVER	1	
14*	31233ZE2003	INSULATOR	1	
15*	90110ZE2003	SCREW-WASHER, 4X6	1	
16*	91601ZE2003	PACKING	1	
17*	938920501418	SCREW-WASHER, 5X14	1	
18*	938920503218	SCREW-WASHER, 5X32	4	
19*	9407206080	NUT-WASHER, 6MM	2	
20	957010803508	BOLT, FLANGE, 8X35	2	

HONDA GX340K1 ENGINE — GOVERNOR CONTROLS ASSY.

GOVERNOR CONTROLS ASSY.

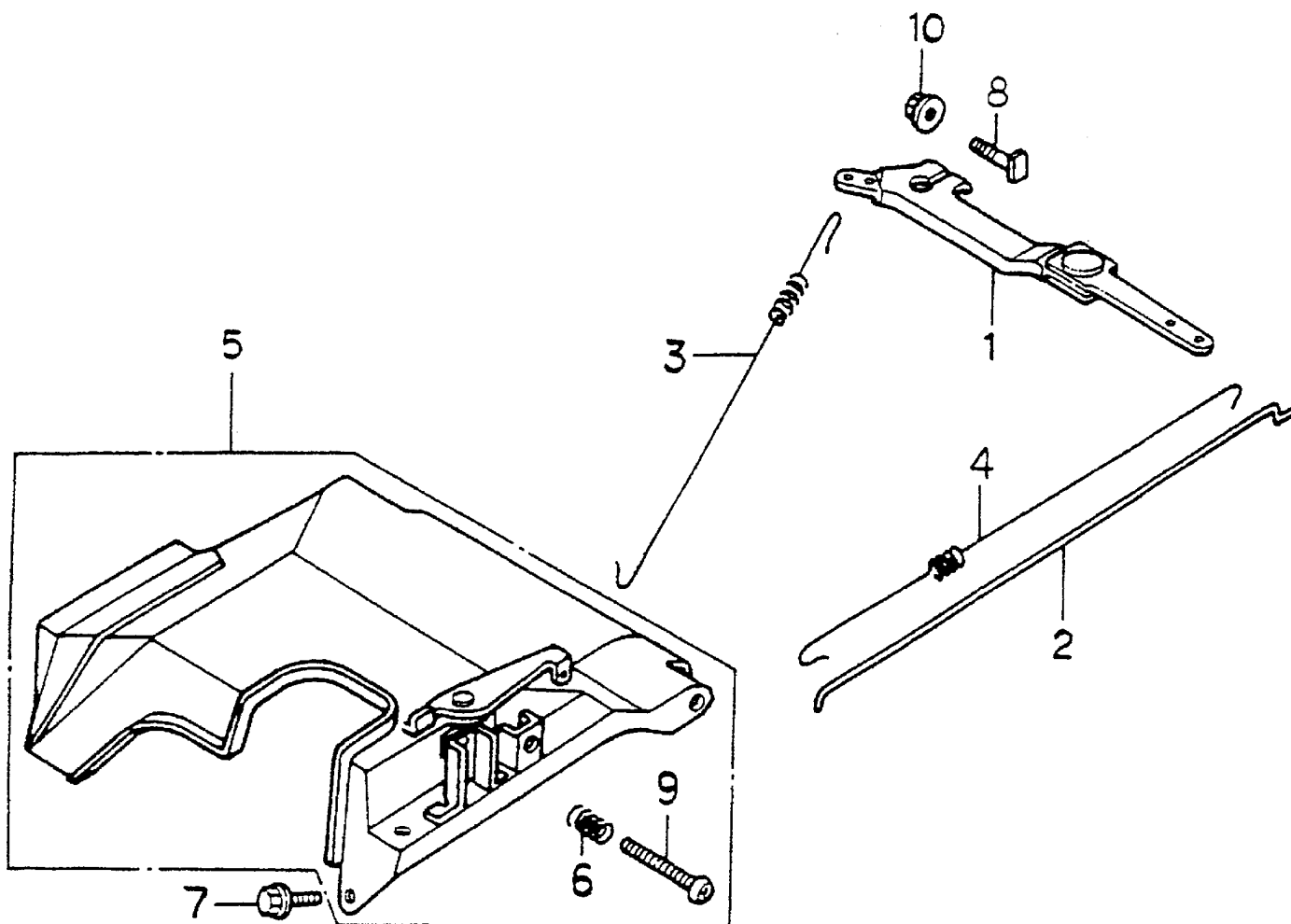

HONDA GX340K1 ENGINE — GOVERNOR CONTROLS ASSY.

GOVERNOR CONTROLS ASSY.

<u>NO</u>	<u>PART NO</u>	<u>PART NAME</u>	<u>QTY.</u>	<u>REMARKS</u>
1	16550ZE3700	ARM, GOVERNOR	1	
2	16555ZE3000	ROD, GOVERNOR	1	
3	16561ZE3000	SPRING, GOVERNOR	1	
4	16562ZE3700	SPRING, THROTTLE RETURN	1	
5	16570ZE3700	CONTROL ASSY.	1 INCLUDES ITEMS W/*
6*	16584883300	SPRING, CONTROL ADJUSTING	1	
7	90013883000	BOLT, FLANGE, 6X12	1	
8	90015ZE5010	BOLT, GOVERNOR ARM	1	
9*	93500050350A	SCREW, PAN, 5X35	1	
10	9405006000	NUT, FLANGE, 6MM	1	

HONDA GX340K1 ENGINE — CARBURETOR ASSY.

CARBURETOR ASSY.

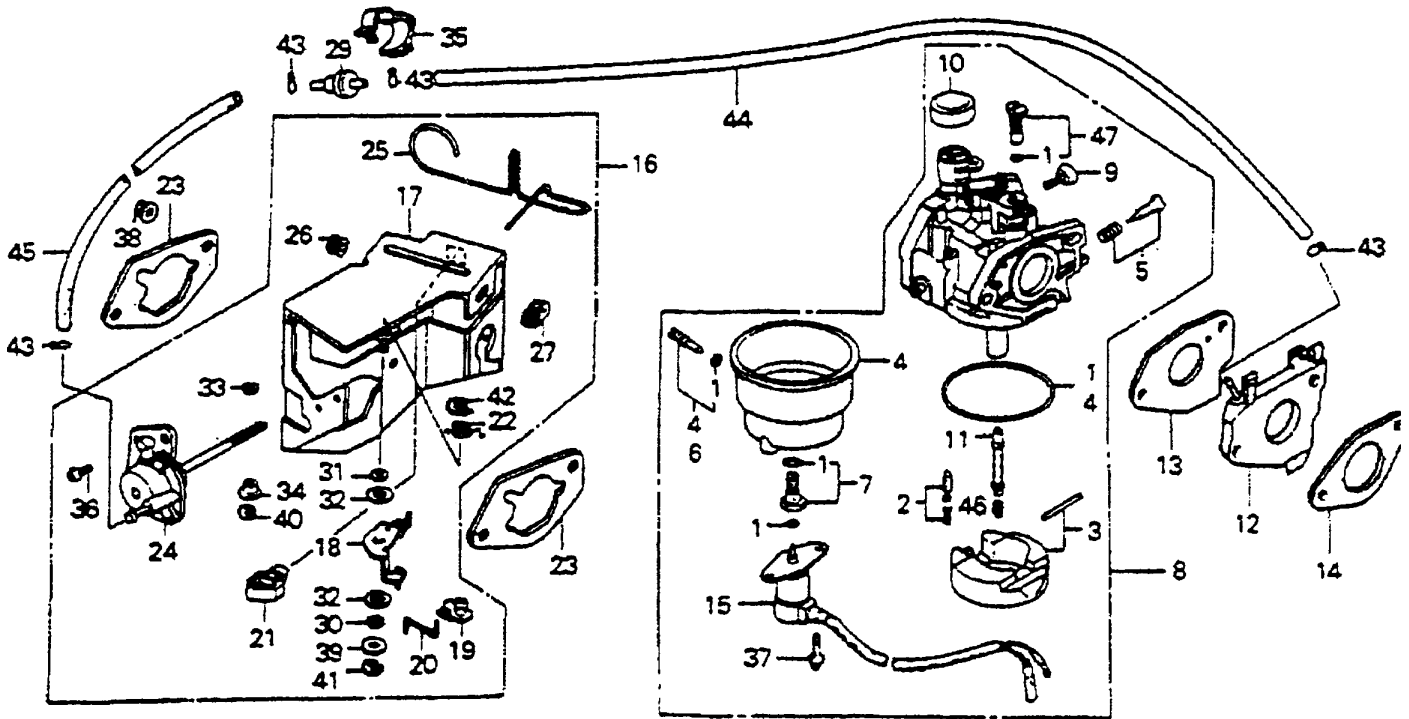

HONDA GX340K1 ENGINE — CARBURETOR ASSY.

CARBURETOR ASSY.

NO	PART NO	PART NAME	QTY.	REMARKS
1*	16010ZE3701	GASKET SET	1	
2*	16011ZA0931	VALVE SET, FLOAT	1	
3*	16013ZA0931	FLOAT SET	1	
4*	16015ZA0931	CHAMBER SET, FLOAT	1	
5	16016ZH7W01	SCREW SET	1	
6*	16024124761	SCREW SET, DRAIN	1	
7*	16028ZA0931	SCREW SET	1	
8	16100ZE3F10	CARBURETOR ASSY.	1	INCLUDES ITEMS W/*
9*	16124ZE0005	SCREW, THROTTLE STOP	1	
10*	16148141881	CAP, CHOKE DUST	1	
11	16166ZE3701	NOZZLE, MAIN	1	
12	16211ZE3700	INSULATOR, CARBURETOR	1	
13	16221ZE3800	PACKING, CARBURETOR	1	
14	16223ZE3800	PACKING, INSULATOR	1	
15*	16230ZE3701	VALVE ASSY., SOLENOID	1	
16	16260ZE2722	STAY, MANUAL CHOKE	1	INCLUDES ITEMS W/#
17#	16261ZE2702	STAY, COMP., SOLENIOD	1	
18#	16262ZE2711	LEVER, CHOKE	1	
19#	16263ZA0000	JOINT, ROD	1	
20#	16264ZE2701	ROD, CHOKE	1	
21#	16265ZE2721	STOPER, CHOKE ROD	1	
22#	16268ZE2721	SPRING, MANUAL CHOKE	1	
23	16269ZA0800	PACKING, AIR CLEANER	2	
24#	16400ZE2703	DIAPHRAGM ASSY.	1	
25#	16611ZE2711	ROD, CHOKE CONTROL	1	
26#	16613893000	GROMMET, CHOKE ROD	1	
27#	16615893000	GUIDE, CHOKE ROD	1	
29	36135ZV1003	VALVE, DASHPOT CHECK	1	
30#	53149964003	BUSH, ARM PIVOT	1	
31#	90431ZE2700	WASHER, CHOKE LEVER	1	
32#	90432ZE2700	SEAL, CHOKE LEVER	2	
33#	90433ZE2700	WASHER, THRUST	1	
34#	90434ZE2700	COLLAR, LOVER	1	
35	90650SD9003	CLIP, WIRE HARNESS	1	
36#	93500050120A	SCREW, PAN, 5X12	2	
37*	938920501208	SCREW, WASHER 5X12	2	
38	9405006000	NUT, FLANGE, 6MM	2	
39#	9410305000	WASHER, PLAIN 5MM	1	
40#	9454002010	E-RING 2MM	1	
41#	9454004010	E-RING 4MM	1	
42#	9454007010	E-RING 7MM	1	
43	9500202070	CLIP B7, TUBE	4	
44	950053507510	TUBE, 3.5X75	1	
45	950053513010	TUBE, 3.5X130	1	
46*	99101ZF50920	JET, MAIN, #92	1	
	99101ZF50950	JET, MAIN, #95	1	

HONDA GX340K1 ENGINE — SOLENOID ASSY.

SOLENOID ASSY.

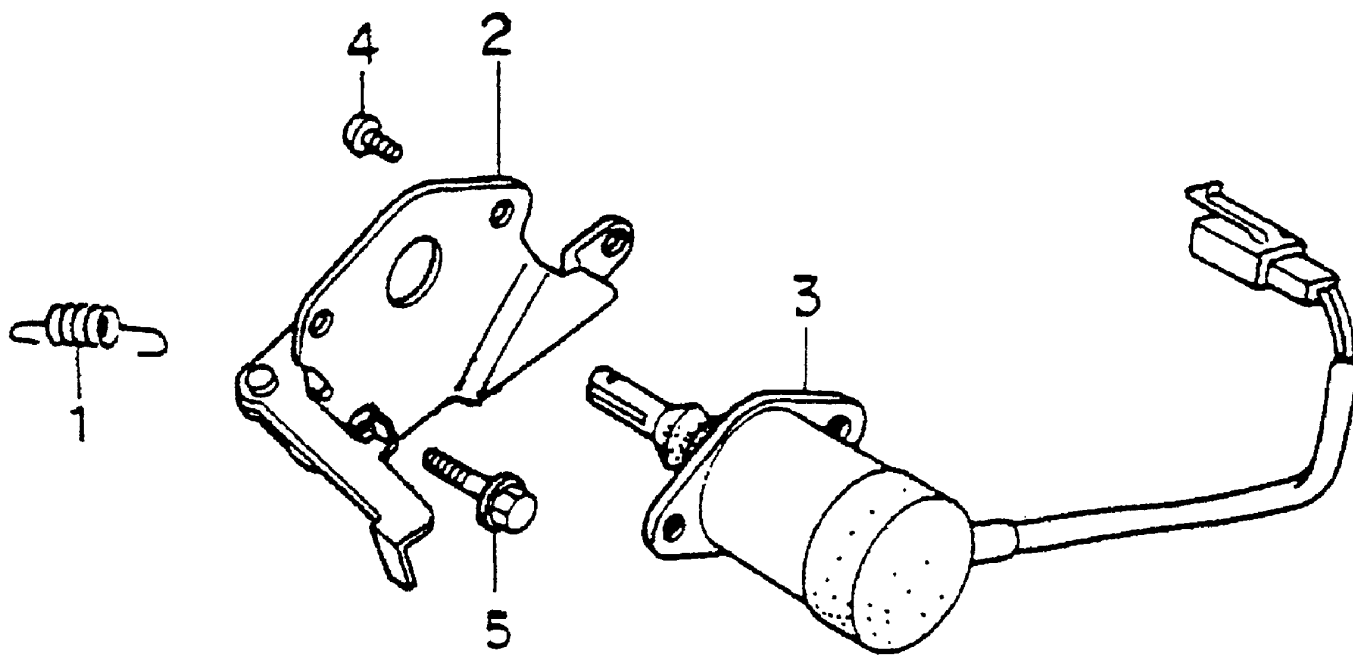

HONDA GX340K1 ENGINE — SOLENOID ASSY.

SOLENOID ASSY.

<u>NO</u>	<u>PART NO</u>	<u>PART NAME</u>	<u>QTY.</u>	<u>REMARKS</u>
1	16268893000	SPRING, CHOKE RETURN	1	
2	17850ZD1E30	LEVER COMP., THROTTLE	1	
3	36160ZB4003	SOLENOID ASSY.	1	
4	93500050080A	SCREW, PAN	2	
5	90013883000	BOLT, FLANGE, 6X2	1	

HONDA GX340K1 ENGINE — FUEL COCK ASSY.

FUEL COCK ASSY.

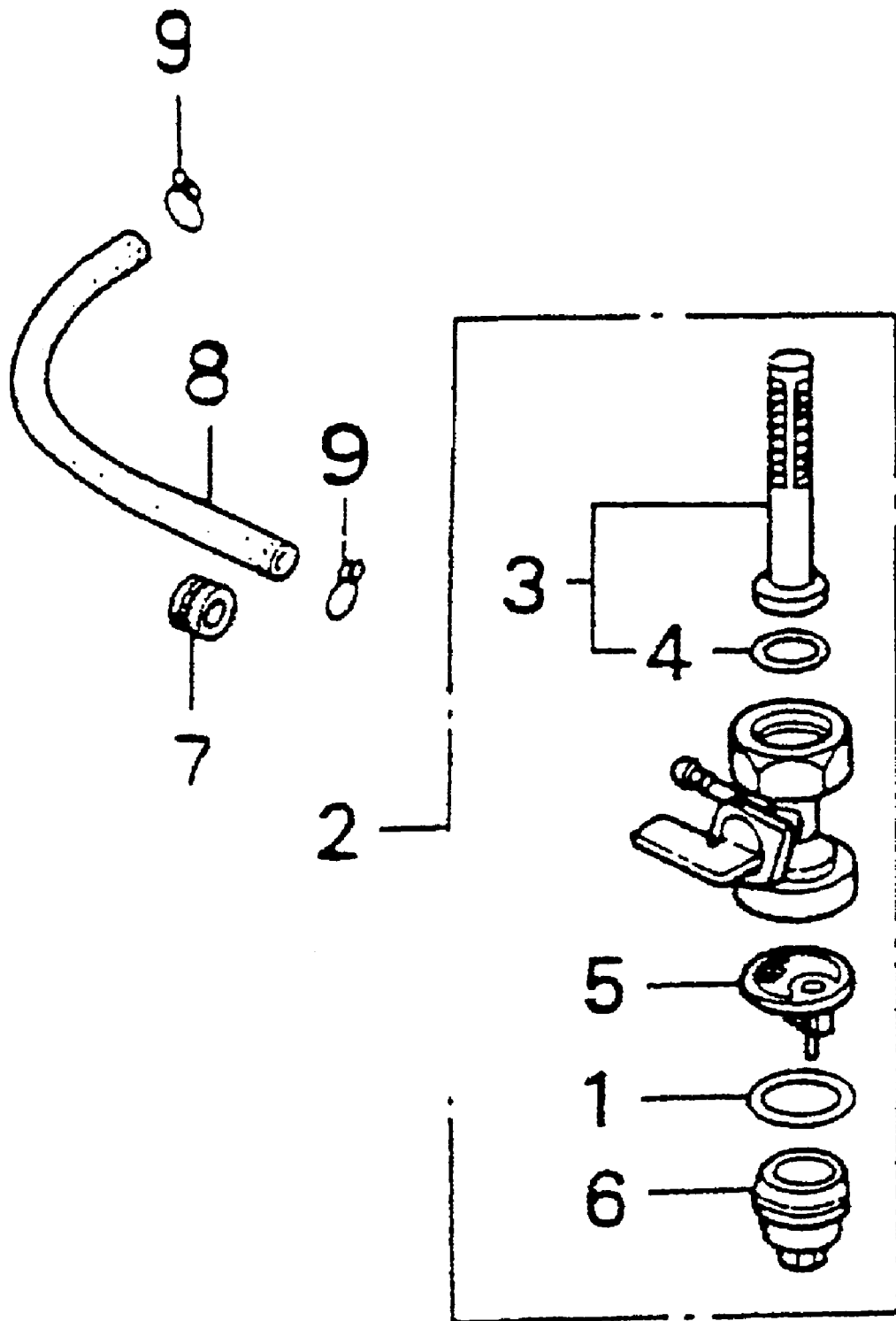

HONDA GX340K1 ENGINE — FUEL COCK ASSY.

FUEL COCK ASSY.

<u>NO</u>	<u>PART NO</u>	<u>PART NAME</u>	<u>QTY.</u>	<u>REMARKS</u>
1*	16173001004	PACKING, FUEL STRAINER CUP	1	
2	16950ZB4015	COCK ASSY., FUEL	1 INCLUDES ITEMS W/*
3*	16952ZB4005	SCREEN, FUEL STRAINER	1	
4*	16958397771	O-RING	1	
5*	16959471831	FILTER CUP	1	
6*	16967GA6671	CUP, FUEL STRAINER	1	
7	90854ZB2000	RUBBER, FUEL TUBE	1	
8	950014521040	TUBE, FUEL, 4.5X210	1	
9	9500202080	CLIP B8, TUBE	2	

PAYMENT TERMS

Terms of payment for parts are net 10 days.

FREIGHT POLICY

All parts orders will be shipped collect or prepaid with the charges added to the invoice. All shipments are F.O.B. point of origin. Multiquip's responsibility ceases when a signed manifest has been obtained from the carrier, and any claim for shortage or damage must be settled between the consignee and the carrier.

MINIMUM ORDER

The minimum charge for orders from Multiquip is \$15.00 net. Customers will be asked for instructions regarding handling of orders not meeting this requirement.

RETURNED GOODS POLICY

Return shipments will be accepted and credit will be allowed, subject to the following provisions:

1. A Returned Material Authorization must be approved by Multiquip prior to shipment.
2. To obtain a Return Material Authorization, a list must be provided to Multiquip Parts Sales that defines item numbers, quantities, and descriptions of the items to be returned.
 - a. The parts numbers and descriptions must match the current parts price list.
 - b. The list must be typed or computer generated.
 - c. The list must state the reason(s) for the return.
 - d. The list must reference the sales order(s) or invoice(s) under which the items were originally purchased.
 - e. The list must include the name and phone number of the person requesting the RMA.
3. A copy of the Return Material Authorization must accompany the return shipment.
4. Freight is at the sender's expense. All parts must be returned freight prepaid to Multiquip's designated receiving point.
5. Parts must be in new and resalable condition, in the original Multiquip package (if any), and with Multiquip part numbers clearly marked.
6. The following items are not returnable:
 - a. Obsolete parts. (If an item is listed in the parts price book as being replaced by another item, it is obsolete.)
 - b. Any parts with a limited shelf life (such as gaskets, seals, "O" rings, and other rubber parts) that were purchased more than six months prior to the return date.
 - c. Any line item with an extended dealer net price of less than \$5.00.
 - d. Special order items.
 - e. Electrical components.
 - f. Paint, chemicals, and lubricants.
 - g. Decals and paper products.
 - h. Items purchased in kits.
7. The sender will be notified of any material received that is not acceptable.
8. Such material will be held for 5 working days from notification, pending instructions. If a reply is not received within 5 days, the material will be returned to the sender at his expense.
9. Credit on returned parts will be issued at dealer net price at time of the original purchase, less a 15% restocking charge.
10. In cases where an item is accepted for which the original purchase document can not be determined, the price will be based on the list price that was effective twelve months prior to the RMA date.
11. Credit issued will be applied to future purchases only.

PRICING AND REBATES

Prices are subject to change without prior notice. Price changes are effective on a specific date and all orders received on or after that date will be billed at the revised price. Rebates for price declines and added charges for price increases will not be made for stock on hand at the time of any price change.

Multiquip reserves the right to quote and sell direct to Government agencies, and to Original Equipment Manufacturer accounts who use our products as integral parts of their own products.

SPECIAL EXPEDITING SERVICE

A \$20.00 to \$50.00 surcharge will be added to the invoice for special handling including bus shipments, insured parcel post or in cases where Multiquip must personally deliver the parts to the carrier.

LIMITATIONS OF SELLER'S LIABILITY

Multiquip shall not be liable here under for damages in excess of the purchase price of the item with respect to which damages are claimed, and in no event shall Multiquip be liable for loss of profit or good will or for any other special, consequential or incidental damages.

LIMITATION OF WARRANTIES

No warranties, express or implied, are made in connection with the sale of parts or trade accessories nor as to any engine not manufactured by Multiquip. Such warranties made in connection with the sale of new, complete units are made exclusively by a statement of warranty packaged with such units, and Multiquip neither assumes nor authorizes any person to assume for it any other obligation or liability whatever in connection with the sale of its products. A part from such written statement of warranty, there are no warranties, express, implied or statutory, which extend beyond the description of the products on the face hereof.

PARTS AND OPERATION MANUAL

HERE'S HOW TO GET HELP

*PLEASE HAVE THE MODEL AND SERIAL NUMBER
ON-HAND WHEN CALLING*

PARTS DEPARTMENT

800-427-1244 or 310-537-3700

FAX: 800-672-7877 or 310-637-3284

SERVICE DEPARTMENT/TECHNICAL ASSISTANCE

800-478-1244 or 310-537-3700

FAX: 310- 537-4259

WARRANTY DEPARTMENT

888-661-4279, or 310-661-4279

FAX: 310- 537-1173

MAIN

800-421-1244 or 310-537-3700

FAX: 310-537-3927

Manufactured for MULTIQUIP INC.
by
DENYO MANUFACTURING CO., JAPAN



MULTIQUIP INC.

POST OFFICE BOX 6254
CARSON, CA 90749
310-537-3700 • 800-421-1244
FAX: 310-537-3927
E-MAIL: mq@multiquip.com
WWW: multiquip.com

Atlanta • Boise • Dallas • Houston • Newark
Quebec, Canada • Manchester, UK • Rio De Janiero, BR • Guadalajara, MX

Free Manuals Download Website

<http://myh66.com>

<http://usermanuals.us>

<http://www.somanuals.com>

<http://www.4manuals.cc>

<http://www.manual-lib.com>

<http://www.404manual.com>

<http://www.luxmanual.com>

<http://aubethermostatmanual.com>

Golf course search by state

<http://golfingnear.com>

Email search by domain

<http://emailbydomain.com>

Auto manuals search

<http://auto.somanuals.com>

TV manuals search

<http://tv.somanuals.com>