

PARTS AND OPERATION MANUAL

MULTIQUIP **Model GA-9.7 HZ** **A.C. GENERATOR**

© COPYRIGHT 2001, MULTIQUIP INC.

Revision #2 (03/05/01)



MULTIQUIP INC.

18910 WILMINGTON AVE.
CARSON, CALIFORNIA 90746
310-537-3700
800-421-1244
FAX: 310-537-3927

PARTS DEPARTMENT:

800-427-1244
FAX: 800-672-7877

SERVICE DEPARTMENT/TECHNICAL ASSISTANCE:

800-478-1244
FAX: 310-631-5032

E-mail: mq@multiquip.com • **www:** multiquip.com

Atlanta • Boise • Dallas • Houston • Newark
Montreal, Canada • Manchester, UK
Rio De Janeiro, Brazil • Guadalajara, Mexico



WARNING



CALIFORNIA — Proposition 65 Warning

Engine exhaust and some of its constituents are known to the State of California to cause cancer, birth defects and other reproductive harm.

HERE'S HOW TO GET HELP

*PLEASE HAVE THE MODEL AND SERIAL NUMBER
ON-HAND WHEN CALLING*

PARTS DEPARTMENT

800-427-1244 or 310-537-3700

FAX: 800-672-7877 or 310-637-3284

SERVICE DEPARTMENT/TECHNICAL ASSISTANCE

800-478-1244 or 310-537-3700

FAX: 310- 537-4259

WARRANTY DEPARTMENT

888-661-4279, or 310-661-4279

FAX: 310- 537-1173

MAIN

800-421-1244 or 310-537-3700

FAX: 310-537-3927

Here's How To Get Help	3
Table Of Contents	4
Parts Ordering Procedures	5
Rules For Safe Operation	6
Operation and Safety Decals	7
Specifications	8
General Information	9

Multiquip GA-9.7 HZ — AC Generator

Controls and Indicators	10
Installation	11
Pre-Setup	12-13
Instrumentation	14
Load Application	15
Operating Instructions	16
Maintenance	17
Preparation For Long Term Storage	18
Wiring Diagram	19
Troubleshooting (Engine)	20-21
Troubleshooting (Generator)	22-23
Explanation Of Codes In Remarks Column	24
Suggested Spare Parts	25
Generator Assembly	26-27
Control Box Assembly	28-29
Pipe Frame Assembly	30-31
Nameplate And Decals	32-33

Honda GX610 K1 Engine

Cylinder Head Assembly	34-35
Cylinder Barrel Assembly	36-37
Crankcase Cover Assembly	38-39
Crankshaft Assembly	40-41
Piston Assembly	42-43
Camshaft Assembly	44-45
Recoil Starter Assembly	46-47
Fan Cover Assembly	48-49
Carburetor Assembly	50-51
Air Cleaner Assembly	52-53
Muffler Assembly	54-55
Fuel Pump Assembly	56-57
Flywheel Assembly	58-59
Ignition Coil Assembly	60-61
Starter Motor Assembly	62-63
Governor Control Assembly	64-65
Labels	66-67
Gasket Kit	68

Terms and Conditions Of Sale — Parts	69
--	----

NOTE

***Specification and part number
are subject to change without
notice.***

- Dealer account number
- Dealer name and address
- Shipping address (if different than billing address)
- Return fax number
- Applicable model number
- Quantity, part number and description of each part
- Specify preferred method of shipment:
 - UPS Ground
 - UPS Second Day or Third Day*
 - UPS Next Day*
 - Federal Express Priority One (please provide us with your Federal Express account number)*
 - Airborne Express*
 - Truck or parcel post

**Normally shipped the same day the order is received, if prior to 2PM west coast time.*

Earn Extra Discounts when you order by FAX!

All parts orders which include complete part numbers and are received by fax qualify for the following extra discounts:

<u>Number of line items ordered</u>	<u>Additional Discount</u>
1-9 items	3%
10+ items**	5%

Get special freight allowances when you order 10 or more line items via FAX! **

- UPS Ground Service at no charge for freight
- PS Third Day Service at one-half of actual freight cost

No other allowances on freight shipped by any other carrier.

**Common nuts, bolts and washers (all items under \$1.00 list price) do not count towards the 10+ line items.

DISCOUNTS ARE SUBJECT TO CHANGE

Fax order discount and UPS special programs revised June 1, 1995

**Extra Fax Discount
for Domestic USA
Dealers Only**

**Up to 5%
extra savings!**

**UPS
Special**
For faxed orders only

**Now! Direct TOLL-FREE access
to our Parts Department!**

Toll-free nationwide:

800-421-1244

Toll-free FAX:

800/6-PARTS-7 • 800-672-7877

CAUTION:



Failure to follow instructions in this manual may lead to serious injury or even death! This equipment is to be operated by trained and qualified personnel only! This equipment is for industrial use only.

The following safety guidelines should always be used when operating the GA-9.7 HZ Generator:

GENERAL SAFETY

- **DO NOT** operate or service this equipment before reading this entire manual.
- This equipment should not be operated by persons under 18 years of age.
- **NEVER** operate this equipment without proper protective clothing, shatterproof glasses, steel-toed boots and other protective devices required by the job.
- This generator is a source of potentially **LETHAL** high voltage. Never permit unqualified personnel—especially children to operate the generator.
- Always refuel in a well-ventilated area, away from sparks and open flames.
- Always use extreme caution when working with **flammable** liquids. When refueling, **stop the engine** and allow it to cool. **DO NOT** smoke around or near the machine. Fire or explosion could result from fuel vapors, or if fuel is spilled on a hot engine.
- This generator is equipped with a **ground terminal** for your protection. Always complete the grounding path from the generator to an external grounding source.
- **NEVER** operate this generator, or handle any electrical equipment while standing in **water, while bare foot, while hands are wet, or in the rain**. *Electrical shock could occur causing severe bodily harm or even death.*
- Keep electrical cords in good condition. Worn, bare or frayed wiring can cause electrical shock, leading to *bodily harm or even death.*
- This generator requires an adequate free flow of cooling air. Never operate the generator in any enclosed or narrow area where free flow of the air is restricted. If the air flow is restricted it will cause serious damage to the generator and may cause injury to people.
- **NEVER** touch the hot exhaust manifold, muffler or cylinder. Allow these parts to cool before servicing generator.

- Provide adequate ventilation when operating the generator. **DO NOT** operate the generator in any enclosed or narrow space. The generator's gasoline engine gives off **DEADLY** carbon monoxide gas.
- **NEVER** operate the generator in an explosive atmosphere or near combustible materials. An explosion or fire could result causing severe *bodily harm or even death.*
- Always make sure that the generator is secure on level ground so that it cannot slide or shift around, endangering workers. Also keep the immediate area free of bystanders.
- When using a concrete vibrator or a similar device that is immersed in a water based solution, make sure the device is equipped with short circuit protection.
- Always use rubber boots and gloves when operating a concrete vibrator or similar device.
- Use adequate size connecting cable for extension.
- Maintain electrical cords in good condition and frequently replace the entire cable of the concrete vibrator with a new one.
- **High Temperatures** – Allow the machine and engine to cool before adding fuel or performing service and maintenance functions. Contact with *hot* components can cause serious burns.

Emergencies

- Always know the location of the nearest **fire extinguisher** and **first aid kit**. Know the location of the nearest telephone. Also know the phone numbers of the nearest **ambulance, doctor** and **fire department**. This information will be invaluable in the case of an emergency.

Maintenance Safety

- **NEVER** lubricate components or attempt service on a running machine.
- Always allow the machine a proper amount of time to cool before servicing.
- Keep the machinery in proper running condition.
- Fix damage to the machine immediately and always replace broken parts.
- Dispose of hazardous waste properly. Examples of potentially hazardous waste are used motor oil, fuel and fuel filters.
- **DO NOT** use food or plastic containers to dispose of hazardous waste.
- **DO NOT** pour waste, oil or fuel directly onto the ground, down a drain or into any water source

OPERATION AND SAFETY DECALS

Machine Safety Decals

The GA-9.7 HZ portable generator is equipped with a number of safety decals. These decals are provided for operator safety and maintenance information. The illustration below shows these decals as they appear on the machine. Should any of these decals become unreadable, replacements can be obtained from your dealer.

P/N D2552000404

OPERATING INSTRUCTIONS

1. Before starting check the oil and fuel level.
2. Switch the circuit breaker to the "OFF" position
3. Pull the choke knob.
4. Turn the operation switch to the "ON" position and push the start button to start the engine.
5. After the engine starts, gradually push in the choke valve.
6. Run the generator for 3-5 minutes without load.
7. Check for any abnormal noise or smell.
8. Switch the circuit breaker to the "ON" position.
9. When stopping, remove the load and allow it to continue to run for 2-3 minutes before stopping engine.
10. Turn the operation switch to the "STOP" position



P/N A6562100003

DANGER EXPLOSIVE GASES
Cigarettes, flames or sparks could cause battery to explode. Always shield eyes and face from battery. Do not charge or use booster cables or adjust post connections without proper instruction and training.
KEEP VENT CAPS TIGHT AND LEVEL
POISON CAUSES SEVERE BURNS
Contains sulfuric acid. Avoid contact with skin, eyes or clothing. In event of accident flush with water and call a physician immediately.
KEEP OUT OF REACH OF CHILDREN

P/N 800696604

GROUND



P/N 70800628504

DANGER

- Do not touch output terminals or internal wiring while unit is operating.
- Turn off power before servicing.

ELECTRICAL SHOCK HAZARD

Only qualified personnel should install, use, or service this equipment.

P/N 8700611904

WARNING

- Only operate machine in well ventilated areas.
- Do not inhale exhaust gases.

DANGEROUS GAS

Only qualified personnel should install, use, or service this equipment.

P/N 8700611804

CAUTION

HOT PARTS can burn skin.

- Do not touch until the machine has sufficiently cooled.

P/N B90400030

CAUTION!

- READ OWNER'S SERVICE MANUAL BEFORE OPERATING OR SERVICING THIS MACHINE.
- ALWAYS KEEP UNAUTHORIZED, INEXPERIENCED, UNTRAINED PEOPLE AWAY FROM THIS MACHINE.
- MAKE SURE ALL SAFETY DEVICES ARE OPERATIONAL BEFORE THIS MACHINE IS STARTED. MAKE SURE ENGINE IS TURNED OFF AND SPARK PLUG WIRE DISCONNECTED BEFORE SERVICING THE MACHINE OR COMING IN CONTACT WITH ANY MOVING PART. IF EQUIPMENT IS POWERED BY AN ELECTRIC MOTOR, DISCONNECT ELECTRICAL PLUG.
- NEVER LEAVE MACHINE UNATTENDED WHEN OPERATING. ALWAYS STOP ENGINE AND ALLOW ENGINE TO COOL BEFORE ADDING FUEL OR OIL.

P/N 0820610804

WARNING!

Before connecting this generator to any building's electrical system, a licensed electrician must install an isolation (transfer) switch.

Serious injury or death may result without this transfer switch.

P/N 0820610404

P/N 1630645004 **OIL DRAIN**

P/N 7810880104 **FUEL DRAIN**

CAUTION

Before starting the engine, check that the oil level is within the indicated operating range. If the level is above the H mark or below the L mark, it is important to correct before operating to avoid damage.

OIL LEVEL GAUGE

P/N 8700611524

CAUTION

OPERATE AT 3600 RPM ONLY (FULL THROTTLE)

DAMAGE MAY RESULT IF OPERATED AT LOWER SPEEDS

P/N 7900636004

Table 1. Specifications

MODEL		GA-9.7 HZ
	Type	2-pole, Brushless Type Revolving Field
60 Cycle Generator	Max. Output	9700 Watts
	Rated Output (continuous)	8400 Watts
	Rated Voltage	120/240 V
	Rated Current	20.0/30.0 A
	Phase	Single Phase (3-wire)
	Frequency	60 Hz
	Rated Speed	3600 RPM
	Power Factor	100%
	Max Current (Main Breaker)	2-pole 35 Amps
Engine	Model	Honda GX610K1VD
	Type	Air-cooled 4 stroke OVH 90 V- Twin horizontal shaft gasoline engine
	Bore X Stroke	3.03 in X 2.60 in
	Displacement	18.8 cc
	Rated Output	18.0 H.P./3600 R.P.M.
	Fuel Tank Capacity	Approx. 10 U.S. Gallons
	Fuel	Unleaded Automobile Gasoline
	Lube Oil Capacity	3 1/16 pints
	Speed Control Method	Centrifugal Fly-weight Type
	Starting Method	Electric/Recoil Start
Dimension (LXWXH)		800 X 540 X 700 mm
Dry Net Weight		344 lbs (156 Kg.)

Effects of Altitude and Heat

The maximum output of the engine listed above is applicable to supplying electrical power for continuous service at ambient conditions in accordance with SAE Test cord J607. The above ambient conditions are at standard sea level, with a barometric reading of 29.92 inches and a temperature of 60 degrees fahrenheit.

Generally, the engine output power will decrease 3 1/2% for each 1000 feet of altitude above sea level, and 1% for each 10° F fahrenheit above the standard temperature of 60° F

WARNING:



Before connecting this generator to any building's electrical system, a licensed electrician must install an isolation (transfer) switch.

Serious injury or death may result without this transfer switch.

GA-9.7 HZ FAMILIARIZATION

Generator

The Multiquip Model GA-9.7 HZ generator has been designed as a portable lightweight power source for 60 Hz (single-phase) vibrators, lighting facilities, power tools, submersible pumps and other industrial and construction machinery.

This generator is powered by a **HONDA** gasoline engine. The alternator, a brushless revolving-field type, is permanently aligned to the engine through rigid coupling.

The generator is mounted on rubber vibration isolators that have a steel base backplate which is attached to the protective steel pipe carrying frame. The protective carrying frame is made of steel tubing and fully wraps around the generator to protect against damage.

This portable generator is supplied with a electrical **control box**. To reduce vibration caused by the engine, the control box is also placed on rubber isolators.

Control Box

The control box is provided with the following:

- Three 120/240V output receptacles (single phase).
- Two 120 V output GFI receptacles (single phase).
- Five circuit breakers, one for each receptacle.
- One 240 V, 60 Hz main circuit breaker.
- AC Voltmeter.
- Idle Control Switch.
- Full Power Switch.
- Operation Switch.

Excitation System

All GA-series generators use a magnet attached to a flywheel to produce AC voltage from a lamp coil beneath the flywheel. As the magnet passes the coil it produces approximately 19-22 AC volts.

This voltage (19-22 VAC) is then sent to the control box that contains three rectifying diodes:

- Excitation (diode 1)
- Battery (diode 2)
- Slow Down (diode 3)

The AC voltage will pass through the excitation diode that converts the voltage to DC power.

This DC power is then sent to the excitation windings housed within the main windings commonly called the "stator".

This voltage is then transferred into the rotor through induction. The rotor contains two diodes within it which rectify the DC voltage and send it out through the main windings, as AC voltage.

Engine

The four-cycle air-cooled HONDA gasoline engine is designed to meet every performance requirement of this generator. Reference Table 1, page 8 for engine specifications.

Figure 1 (page 10) shows the basic controls and indicators for the GA-9.7 HZ generator.

NOTE

In keeping with Multiquip's policy of constantly improving its products, the specifications quoted herein are subject to change without prior notice.

GA-9.7 HZ — CONTROLS AND INDICATORS

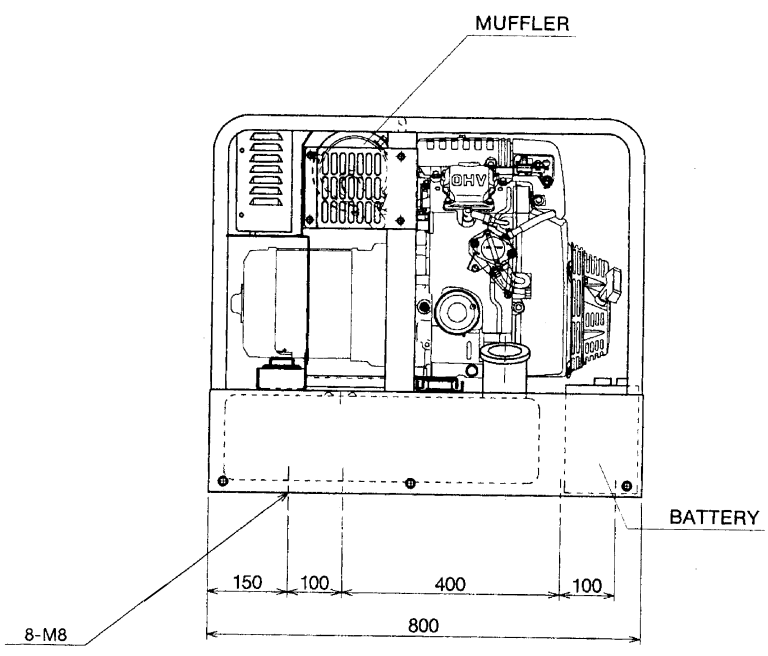
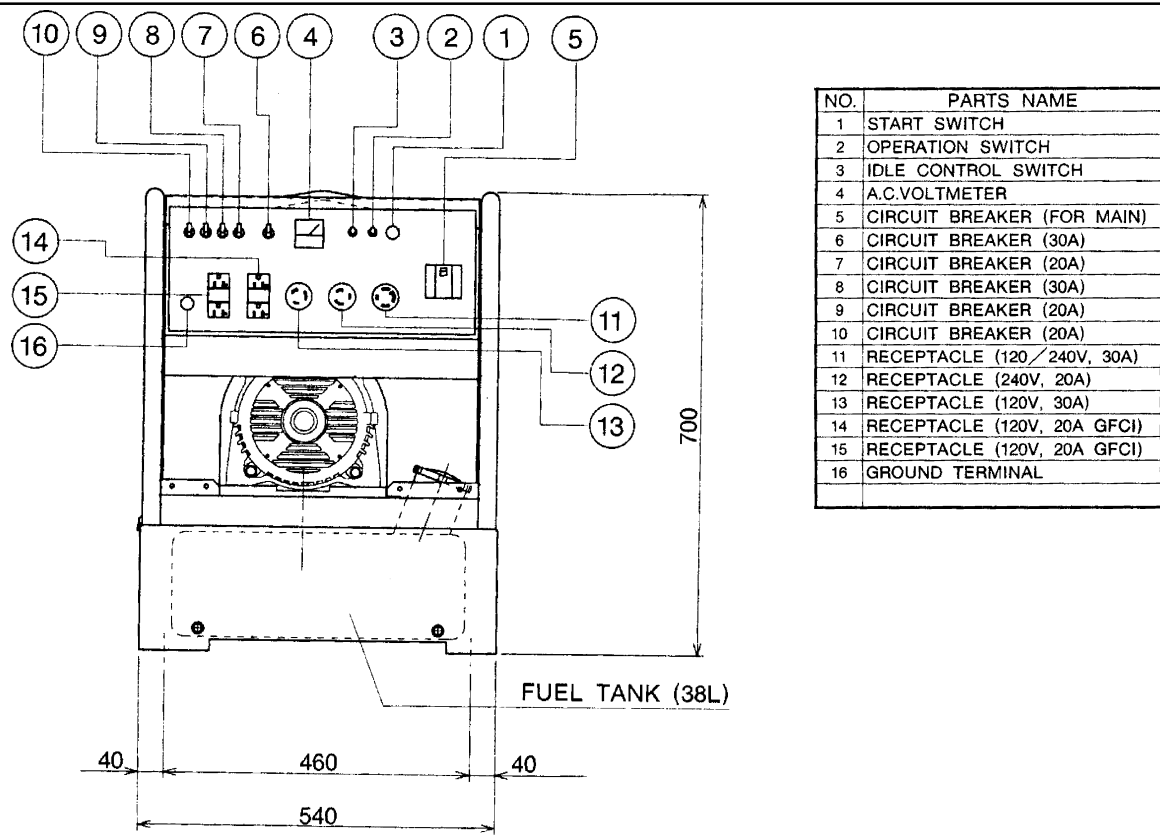

Dry Weight (Approx) : 156kg

Figure 1. Controls and Indicators

Outdoor Installation

Install the generator in a location where it will not be exposed to rain or sunshine. Make sure that the generator is on secure level ground so that it cannot slide or shift around. Also install the generator in a manner so that the exhaust will not be discharged in the direction of nearby homes.

The installation site must be relatively free from moisture and dust. All electrical equipment should be protected from excessive moisture. Failure to do will result in deterioration of the insulation and will result in short circuits and grounding.

Foreign materials such as dust, sand, lint and abrasive materials have a tendency to cause excessive wear, not only to the engine parts, but also to the alternator parts.

CAUTION :



Pay close attention to ventilation when operating the generator inside confined areas. The engine exhaust contains noxious elements.

Indoor Installation

Exhaust gases from gasoline engines are extremely poisonous. Whenever an engine is installed indoors the exhaust fumes must be vented to the outside. The engine should be installed at least two feet from any outside wall. Using an exhaust pipe which is too long or too small can cause excessive back pressure which will cause the engine to heat excessively and possibly burn the valves.

Eliminate the danger of deadly carbon monoxide gas. Remember that exhaust fumes from any gasoline engine are very poisonous if discharged in a closed room, but harmless if allowed to mix with the outside air. If the generator is installed indoors, you must make provisions for venting the engine exhaust to the outside of the building.

CAUTION :



Preventing electrical shock. Pay close attention to handling when operating concrete vibrators. Always use rubber boots and gloves to insulate the body from a short circuit.

General Inspection Prior to Operation

This generator has been thoroughly inspected prior to shipment from the factory. However, be sure to check for damaged parts or components, or loose nuts and bolts, which could have occurred in transit.

Ground

The nut and ground terminal on the generator should always be used to connect the generator to a suitable ground. The ground path should be of #8 size wire.

Connect the terminal of the ground wire between the lock washer and the nut and tighten the nut fully. Connect their end of the wire to a suitable ground.

Ground the Generator

Ground the generator from its ground connector so that resistance to ground is 500 ohms or less.

Ground the Tool

Ground the tool (load) in the same manner as the generator.

Circuit Breaker

To protect the generator from an overload, circuit breakers are provided for single (60 Hz) phase on the control box. Make sure to switch the circuit breakers to the "OFF" position prior to starting the engine.

Extension Cable

When electric power is to be provided to various tools or loads at some distance from the generator, extension cords are normally used. Cables should be sized to allow for distance in length and amperage so that the voltage drop between the generator and point of use (load) is held to a minimum. Use the cable selection chart (Table 2) as a guide for selecting proper cable size.

Table 2. Cable Selection (60 Hz, single phase operation)

Current in Amperes	Load In Watts		Maximum Allowable Cable Length			
	At 120 Volts	At 240 Volts	#10 Wire	#12 Wire	#14 Wire	#16 Wire
2.5	300	600	1000 ft.	600 ft.	375 ft.	250 ft.
5	600	1200	500 ft.	300 ft.	200 ft.	125 ft.
7.5	900	1800	350 ft.	200 ft.	125 ft.	100 ft.
10	1200	2400	250 ft.	150 ft.	100 ft.	
15	1800	3600	150 ft.	100 ft.	65 ft.	
20	2400	4800	125 ft.	75 ft.	50 ft.	
30	3600	7200	75 ft.	50 ft.	35 ft.	

CAUTION: Equipment damage can result from low voltage.

Lubrication Oil

Fill the engine crankcase with lubricating oil through the filler hole, but do not overfill. Make sure the generator is level. With the dipstick inserted all the way, but without being screwed into the filler hole, verify that the oil level is maintained between the two notches on the dipstick.

The oil listed in Table 3 is recommended to ensure better engine performance. Use class SC or higher grade motor oil.

NOTE

This HONDA engine is equipped with a low oil shutdown capability. A built in sensor will automatically turn off the engine should the oil level fall below a safe operating condition. Make sure the generator is placed on level ground. Placing the generator on level ground will ensure that the low oil sensor will function properly.

Fuel

Fill the fuel tank with clean and fresh unleaded gasoline. Do not fill the tank beyond capacity.

Pay attention to the fuel tank capacity when replenishing fuel. Refer to the fuel tank capacity listed on page 8 Specification Table1.

The fuel tank cap must be closed tightly after filling.

Handle fuel in a safety container. If the container does not have a spout, use a funnel.

CAUTION :



Never fill the fuel tank while the engine is running or in the dark. Gasoline spillage on a hot engine can cause a fire or explosion. If gasoline spillage occurs, wipe up the spilled gasoline completely to prevent fire hazards.

Table 3. Recommended Motor Oil

Temperature Range	Type Oil
104° F ~ 23° F (40° C ~ -5°C)	SAE 30
23° F ~ 5° F (-5° C ~ -15°C)	SAE 20 or sae 10W-30
Below 5° C (-15°)	SAE 10W or SAE 10W-30

CAUTION :



When using a combination of dual receptacles, total load should not exceed the rated capacity of the generating.

Power Outlets

The generator has the following 60 Hz 120/240 volt single-phase receptacles.

- Single Phase
 - Two Duplex NEMA (GFCI) 5-20R (120V, 20 Amp)
 - One Twist Lock NEMA L5-30R (120V, 30 Amp)
 - One Twist Lock NEMA L6-20R (240V, 20 Amp)
 - One Twist Lock NEMA L5-30R (120/240, 30 Amp)

Main Circuit Breaker (2-Pole 60 Hz)

This 2-pole 35 amp breaker protects the generator from short circuiting or overloading from the 60 Hz single phase load.

Idle Control Switch

This unit is provided with an automatic idle control for noise suppression and reduced fuel consumption. The automatic idle control automatically engages under a no-load condition. With the automatic idle control switched "ON", the engine revolutions will automatically drop to about 2500 rpm (low-speed operation) within 3 seconds after the load stops. When the operation is resumed, the engine speed is automatically increased to about 3600 rpm (high-speed operation) as soon as the load is connected.

Fuel Gauge

The fuel gauge is located on the fuel tank and allows easy monitoring of the fuel level.

AC Voltmeter

This voltmeter indicates (with a mark) the rated 60 Hz, single phase output voltage. In addition the voltmeter can also be used as a diagnostic tool.

If the voltmeter indicator (needle) is below the rated voltage, engine problems may exist (low/high RPM's). To prevent damage to the generator or power tools turn the generator OFF and consult your authorized Multiquip service dealer.

Single Phase Load

Always be sure to check the nameplate on the generator and equipment to insure the wattage, amperage and frequency requirements are satisfactorily supplied by the generator for operating the equipment.

Generally, the wattage listed on the nameplate of the equipment is its rated output. Equipment may require 130—150% more wattage than the rating on the nameplate, as the wattage is influenced by the efficiency, power factor and starting system of the equipment.

NOTE

If wattage is not given on the equipment's name plate, approximate wattage may be determined by multiplying nameplate voltage by the nameplate amperage.

WATTS = VOLTAGE x AMPERAGE

To determine the running wattage for your load, multiply the running wattage as indicated by steps 1, 2, and 3 below:

1. INCANDESCENT LOADS

Lights, heaters and similar appliances.

Total the running wattage and multiply by 1.

Example:

29 light bulbs @ 100W each = 2.9 KW

use a 3 KW generator.

2. SMALL MOTORS

Drills and other small power tools.

Total the running wattage and multiply by 2.

Example:

A 1 inch drill runs at 1 KW

use a 2 KW generator.

3. LARGE MOTORS

Submersible pumps, table saws etc.

Total the running wattage and multiply by 3.

Example:

A conveyor belt runs at 8 KW

use a 24 KW generator.

CAUTION:



Motors and motor-driven equipment draw much greater current for starting than during operation.

An inadequate size connecting cable which cannot carry the required load can cause a voltage drop which can burn out the appliance or tool and overheat the cable.

The idle control is operated at minimum load capacity of 100W. If the load capacity is less than 100W, throw the idle control switch to the OFF position.

Before Starting

1. Be sure to disconnect the electrical load and switch the main circuit breaker to the "OFF" position prior to starting the engine.
2. Never start the engine with the main circuit breaker "ON".
3. Check the lubricating oil level prior to starting the engine. Make sure the generator is level. The oil level must be maintained between two notches on the dipstick.
4. When there is not enough lubricating oil, fill the crankcase with high grade motor oil. Use a high quality detergent oil classified SC, SD or SE. (See Table 3 on page 13)

CAUTION:



- NEVER start the engine when the oil level is below the lower mark on the dipstick.
- Check the fuel level on the fuel gauge. When fuel is low, fill the fuel tank with clean fresh unleaded automotive gasoline.
- If gasoline spillage occurs, completely wipe up the spilled gasoline.

Starting

1. Place the idle control switch in the "ON" (up) position.
2. Close the choke. Adjust the opening of the choke valve according to operating conditions. When the engine is warm or the air temperature is high, close the choke valve halfway or open it all the way.
3. Confirm that the main circuit breaker on the generator control box is "OFF".
4. Set the operation switch to the "ON" position and grasp the starting rope and slowly pull it out. The resistance becomes hardest at a certain position, corresponding to the compression point. Rewind the rope a little from that point and pull out sharply.
5. If the engine fails to start, repeat the procedure.

CAUTION:



- **DO NOT** pull the starter rope all the way to the end.
- **DO NOT** release the starter rope after pulling. Allow it to rewind as soon as possible.

Warm up

1. When the engine starts, open the choke slowly.
2. Run the engine at low speed for 3 minutes without load until the engine warms up.
3. Turn the idle control switch to the "OFF" (down) position and check the voltage by referring to the voltmeter on the control box.

CAUTION:



DO NOT change the engine speed control lever which has been set at the factory prior to shipping.

1. Check the generator for abnormal noise and smells. Then connect the load to the receptacles of the generator.
2. Switch the main circuit breaker to the "ON" position and turn the idle control switch to the "ON" (down) position for normal (load) engine operation.

Operation

Check the voltage by referring to the voltmeter on the control box. When the voltmeter indicates 120 volts, 120 volts from the 120V receptacles and 240 volts from the 240V receptacle can be obtained at the same time. Refer to Figure 1, Controls and Indicators, item 4 on page 10.

Stopping the Engine

CAUTION:



NEVER stop the engine suddenly while running at high speeds.

1. Remove the load from the generator. Place the circuit breaker in the "OFF" position. Refer to Figure 1, item 5 on page 10. Run the engine (no-load) with the idle control switch set to the ON position for three to five minutes, then stop the engine.
2. Turn the START/STOP switch to the "STOP" position.
3. Never stop the engine suddenly while running at high speed.

General Inspection

At least daily or prior to each use, the generating set should be cleaned and inspected for deficiencies. Check for loose, missing or damaged nuts, bolts or other fasteners. Also check for fuel or oil leaks.

Engine Side (Refer to the Engine Instruction Manual)

Check Oil Level

Check the crankcase oil level prior to each use, or when the fuel tank is filled. Make sure the generating set is level. The oil level must be between the two notches on the dipstick.

Changing Oil

Change oil after the first 20 hours of operation. Drain and refill the engine crankcase every 50 operating hours or once a week thereafter. Drain crankcase oil into a suitable container while engine is still warm. Replace the drain plug tightly. Add oil through the filler hole.

Air Cleaner

Every 50 hours: Remove air cleaner element (std. or heavy duty types), and wash in kerosene or liquid detergent and hot water. Wrap foam element in a cloth and squeeze dry. Wipe heavy duty paper element dry with toweling. Saturate element with kerosene; squeeze excess from foam element. Wipe excess from heavy duty paper element.

Service Daily

If engine is operating in very dusty and dry grass conditions. A clogged air cleaner will result in high fuel consumption, loss of power and excessive carbon buildup in the combustion chamber.

Cleaning the Fuel Strainer

Clean the fuel strainer if it contains dust or water. Remove dust or water in the strainer cap and wash it in gasoline. Securely fasten the fuel strainer cap so that fuel will not leak. Check the fuel strainer every 200 hours of operation or once a month.

Spark Plug

Remove carbon build-up on the spark plug (Figure 5) with a wire brush. Set the spark plug gap to 0.6—0.7mm (0.024-0.028 inch). Tighten with a spark plug socket wrench. Clean the spark plug every 50 operating hours or once a week.

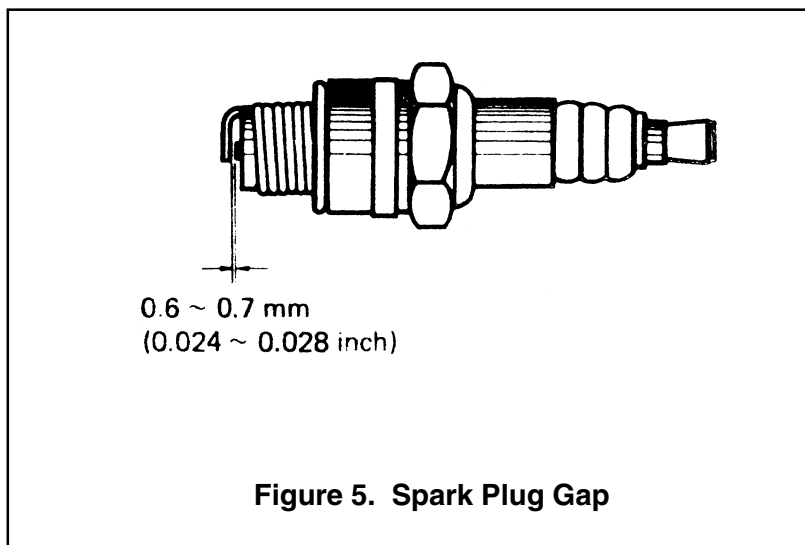

GA-9.7 HZ — PREPARATION FOR LONG -TERM STORAGE

Generator Storage

For storage of the generating set for over 30 days, the following is required:

- Drain the fuel tank completely.
- Run the engine until the gasoline in the carburetor is completely consumed.
- Completely drain the oil from the crankcase and refill with fresh oil.
- Remove the spark plug, pour 2 or 3 cc of SAE 30 oil into the cylinder and crank slowly to distribute the oil.
- Slowly rotate the engine a few times with the starter Rope and install a new plug.
- Pull out the starter rope slowly and stop at the compression point.
- Clean all external parts of the generating set with a cloth.
- Cover the generating set and store in a clean, dry place.

GA-9.7 HZ — WIRING DIAGRAM

SYMBOL	PARTS NAME
Ar	Armature Winding
Fg	Field Winding
EXW1~2	Excitation Winding
II	AC Voltmeter
Re1~5	Rectifier
CON1	Receptacle (120V/240V)
CON2	Receptacle (240V)
CON3	Receptacle (120V)
CON4~5	Receptacle (120V-GFCI)
CB	Circuit Breaker (for MAIN)
CB1	Circuit Breaker (120V/240V-30A)
CB2	Circuit Breaker (240V-20A)
CB3	Circuit Breaker (120V-30A)
CB4~5	Circuit Breaker (120V-20A)
SW1	Idle Control Switch
SW2	Operation Switch
SW3	Starter Switch
RC	Idle Control Device
S	Solenoid
Ry	Relay
F	Fuse

COLOR CODE			
CODE	WIRE COLOR	CODE	WIRE COLOR
B	BLACK	R	RED
L	BLUE	W	WHITE
BR	BROWN	Y	YELLOW
G	GREEN	LB	LIGHT BLUE
GR	GRAY	LG	LIGHT GREEN
V	VIOLET	O	ORANGE
P	PINK		

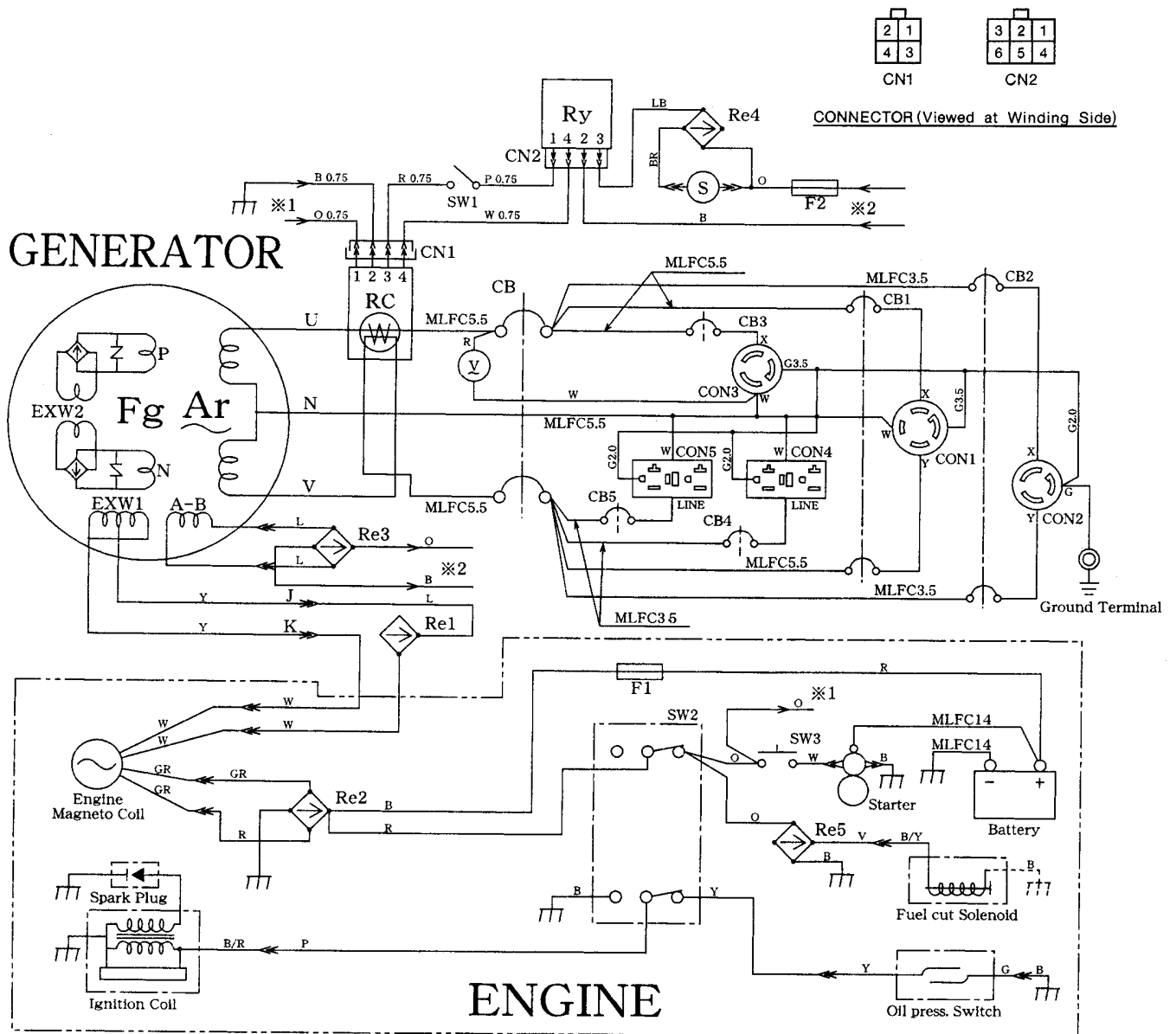

GA-9.7 HZ — TROUBLESHOOTING (ENGINE)

Practically all breakdowns can be prevented by proper handling and maintenance inspections, but in the event of a breakdown, please take a remedial action following the

diagnosis based on the Engine Troubleshooting (Table 4) information shown below and on the proceeding page. If the problem cannot be remedied, please leave the unit just as it is and consult our company's business office or service plant.

TABLE 4. ENGINE TROUBLESHOOTING

SYMPTOM	POSSIBLE PROBLEM	SOLUTION
Poor starting (Engine will not start)	Inspect carburetor to see if fuel is reaching it?	Check fuel line
	No Fuel?	Add Fuel
	Water in fuel tank?	Flush or replace fuel tank.
	Fuel filter clogged?	Replace fuel filter
	Stuck carburetor?	Check float mechanism.
	Spark plug is black?	Spark plug is fouled. Check transistor ignition unit.
	Spark plug is blue-white?	Insufficient compression, injected air leaking. Carburetor jets are clogged (overflow).
	No spark present at tip of spark plug?	Transistor ignition unit broken, high voltage cord cracked or broken. Start/Stop switch broken. Replace spark plug if fouled.
	No oil?	Add oil as required.
Insufficient power output "no compression"	Low oil or oil pressure shutdown sensor is defective?	Check oil level, add oil if necessary. Check automatic oil shutdown circuit "oil sensor" Replace oil sensor.
	Engine will not turn over?	Replace cylinder and piston and if necessary axle joint.
	Cylinder head connecting bolts loose?	Tighten cylinder head connecting bolts.
	Cylinder head gasket damaged?	Replace cylinder head gasket.
	Malfuction of valve seat?	Re-seat valves.
	Spark plug is loose?	Replace spark plug.
Insufficient power output "compression"	Worn piston rings?	Replace piston rings.
	Malfuction in air-cleaner system, air filter clogged?	Clean or replace air filter.
	Air leaking in from interface between carburetor and cylinder head?	Tighten bolts between carburetor and cylinder head. Replace cylinder head gasket.
	Malfuction in fuel system?	Clean or replace fuel filter. Clean or replace carburetor. Check carburetor float.

GA-9.7 HZ — TROUBLESHOOTING (ENGINE)

TABLE 4. ENGINE TROUBLESHOOTING (CONTINUED)

SYMPTOM	POSSIBLE PROBLEM	SOLUTION
Insufficient power output "compression" and overheats	Malfunction in cooling fan?	Check or replace cooling fan.
	Air in-take filter clogged?	Clean or replace air in-take filter.
Burns to much fuel	Over accumulation of exhaust products?	Clean and check valves. Check muffler, replace if necessary.
	Wrong spark plug?	Replace spark plug with manufactures suggested type spark plug.
Exhaust color is continously "WHITE"	Lubricating oil is wrong viscosity?	Replace lubricating oil with correct viscosity.
	Worn rings?	Replace rings
Exhaust color is continously "BLACK"	Air cleanner clogged?	Clean or replace air cleaner.
	Choke valve has not been set to the correct position?	Adjust choke valve to the correct position.
	Carburetor defective, seal on carburetor broken?	Replace carburetor or seal.
	Poor carburetor adjustment "engine runs too rich?"	Adjust carburetor.

GA-9.7 HZ — TROUBLESHOOTING (GENERATOR)

Practically all generator breakdowns can be prevented by proper handling and maintenance inspections, but in the event of a breakdown, please take a remedial action following the

diagnosis based on the Generator Troubleshooting (Table 5) information shown below and on the preceding page. If the problem cannot be remedied, please leave the unit just as it is and consult our company's business office or service plant.

TABLE 5. GENERATOR TROUBLESHOOTING

SYMPTOM	POSSIBLE PROBLEM	SOLUTION
Low voltage	Engine speed too low?	Raise engine speed to rated RPM.
Low voltage. Engine speed normal 3650 RPM (unloaded), 2500 RPM (idle)	AC voltmeter not working?	Replace Ac voltmeter.
	Control box internal wiring malfunction?	Check control box wiring.
	Defective ignition coil?	Check red and green ignition wires. Replace ignition wires if necessary.
	Rotor winding malfunction?	Check or replace rotor.
	Stator winding malfunction?	Check or replace stator.
	Leakage breaker malfunction?	Check or replace CB1 or CB2.
	Full power switch malfunction?	Check full power switch and full power switch circuit.
Voltage output too high.	Engine speed too high?	Lower engine speed to rated RPM.
Voltage output too high. Engine speed normal 3650 RPM (unloaded), 2500 RPM (idle)	Control box internal wiring malfunction	Check control box wiring.
Circuit breaker will not turn on "NO LOAD"	Defective circuit breaker?	Replace circuit breaker.
Circuit breaker will turn on "LOADED" but trips immediately.	Overload?	Reduce load or replace breaker.
	Load circuit is shorted?	Check load circuit for short.
Does not accelerate from low to high "NO LOAD"	Stuck solenoid?	Check solenoid.
	Bad Idle control switch?	Check or replace idle control switch.
Does not accelerate from low to high "LOAD ACTIVE"	Idle control switch malfunction?	Check or replace idle control switch.
	Idle control device malfunction?	Check or replace idle control device.
	Control box internal wiring defective?	Check control box wiring.

GA-9.7 HZ — TROUBLESHOOTING (GENERATOR)

TABLE 5. GENERATOR TROUBLESHOOTING (CONTINUED)

SYMPTOM	POSSIBLE PROBLEM	SOLUTION
Does not decelerate no "VOLTAGE OUTPUT".	Defective rotor windings?	Check or replace rotor.
	Defective solenoid?	Check or replace solenoid.
	Defective idle control device?	Check or replace idle control device.
	Defective solenoid?	Check or replace idle control device.
Does not decelerate but has "VOLTAGE OUTPUT".	Control box wiring malfunction?	Check control box wiring, replace any defective components.
	Defective solenoid?	Check or replace solenoid.
	Idle control device malfunction?	Check or replace idle control device.

GA-9.7 HZ — EXPLANATION OF CODE IN REMARKS COLUMN

How to read the marks and remarks used in this parts book.

Items Found In the “Remarks” Column

Serial Numbers-Where indicated, this indicates a serial number range (inclusive) where a particular part is used.

Model Number-Where indicated, this shows that the corresponding part is utilized only with this specific model number or model number variant.

Items Found In the “Items Number” Column

All parts with same symbol in the number column, *, #, +, %, or ■, belong to the same assembly or kit.

NOTE

If more than one of the same reference number is listed, the last one listed indicates newest (or latest) part available.

NOTE

The contents of this catalog are subject to change without notice.

GA-9.7 1 TO 3 UNITS WITH HONDA GX610K1VD ENGINE

1 to 3 Units

Qty.	P/N	Description
4	0601823204	RECTIFIER
4	0601823754	RELAY
1	0601807459	CIRCUIT BREAKER
2	0601812529	RECEPTABLE
1	0601811032	RECEPTACLE, 250V, 20A
2	0601811031	RECEPTACLE
1	0601812597	RECEPTACLE
1	0601806425	CIRCUIT BREAKER
1	0601806036	CIRCUIT BREAKER
4	0601806424	CIRCUIT BREAKER
1	0601806423	CIRCUIT BREAKER
1	0601830771	IDLE CONTROL SWITCH
1	0601830796	OPERATION SWITCH
1	0663000010	BUTTON STARTER
2	0601802137	FUSE
2	0810105900	CAP FUEL STRAINER
1	0602125032	GAUGE FUEL
2	D9312600104	SUSPENSION RUBBER
2	7605419004A	SUSPENSION RUBBER
3	9807956846	SPARK PLUG
3	15400PR3004	CARTRIDGE FILTER, OIL
1	35480ZJ1812	SWITCH ASSY, OIL LEVEL
1	16100ZJ0892	CARBURETOR ASSY.
3	17010ZJ1000	ELEMENT SET AIR CLEANER
2	16910ZE8015	FILTER COMP FUEL

NOTE

Part numbers on this Suggested Spare Parts List may supercede/replace the P/N shown in the text pages of this book.

GA-9.7 HZ — GENERATOR ASSY.

GENERATOR ASSY.

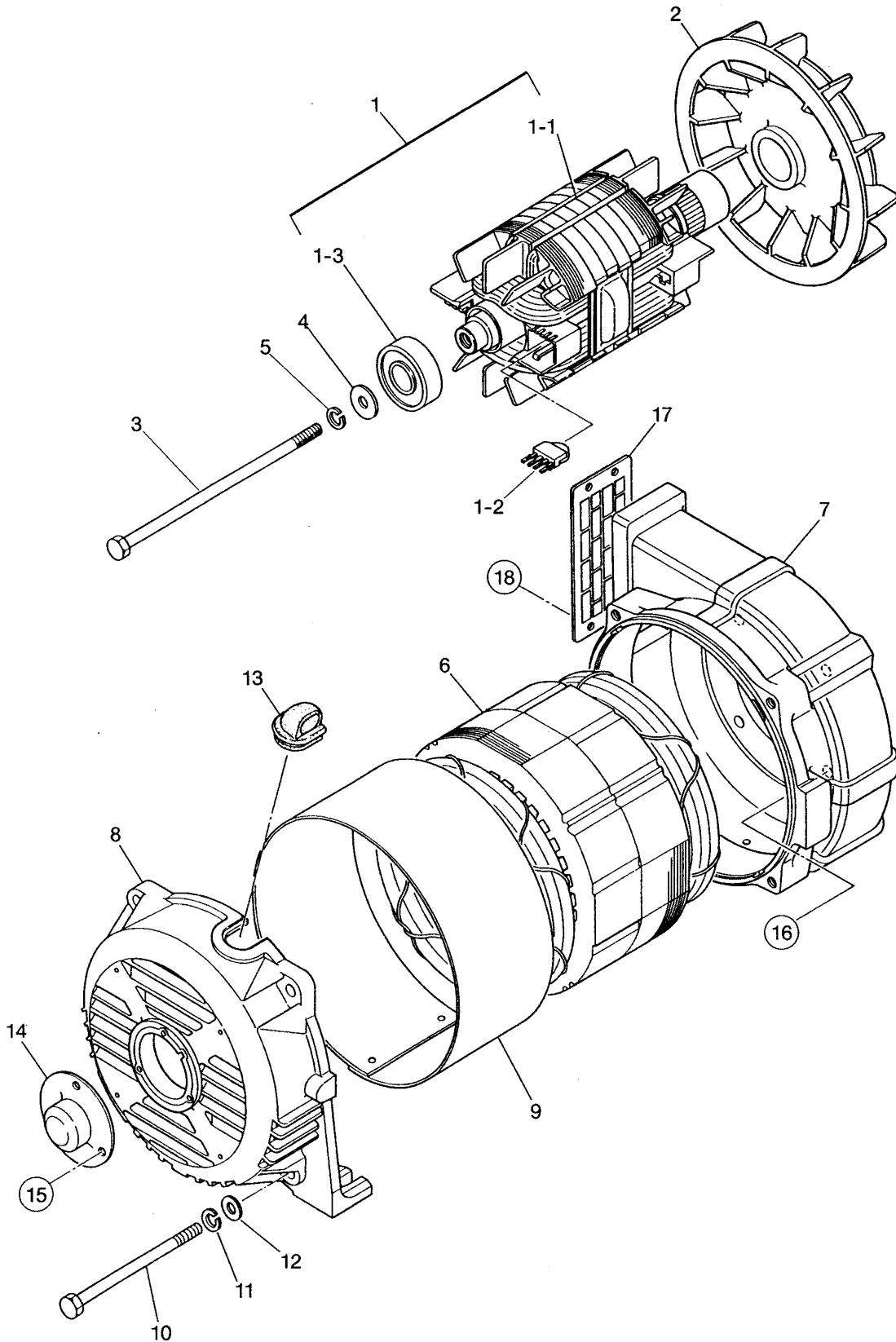

GA-9.7 HZ — GENERATOR ASSY.

GENERATOR ASSY.

<u>NO</u>	<u>PART NO</u>	<u>PART NAME</u>	<u>QTY.</u>	<u>REMARKS</u>
1	A6110200103	ROTOR ASSY.	1	INCLUDES ITEMS W/*
1-1*		FIELD ASSY.	1	
1-2*	7871025004	RECTIFIER	2	
1-3*	042006304	BEARING	1	REPLACES 0071206304
2	A6113100004	FAN	1	
3	A6113400004	SET BOLT, ROTOR	1	
4	0801086104	SET WASHER BEARING	1	
5	0040010000	SPRING WASHER	1	
6	A6136000103	ARMATURE ASSY.	1	
7	A6155100102	END BRACKET	1	
8	A6155000002	END BRACKET	1	
9	A6133300003	COVER, STATOR	1	
10	A6133500004	SET BOLT, STATOR	4	
11	0040008000	SPRING WASHER	4	
12	031108160	PLAIN WASHER	4	REPLACES 0041208000
13	7871329514	GROMMET	1	
14	A6155400104	COVER, BEARING	1	
15	0027105012	MACHINE SCREW	3	
16	011008020	HEX, HEAD BOLT	4	REPLACES 0010108020
	0040008000	SPRING WASHER	4	
17	A6155400204	COVER	1	
18	0052205008	RIVET	4	

GA-9.7 HZ — CONTROL BOX ASSY.

CONTROL BOX ASSY.

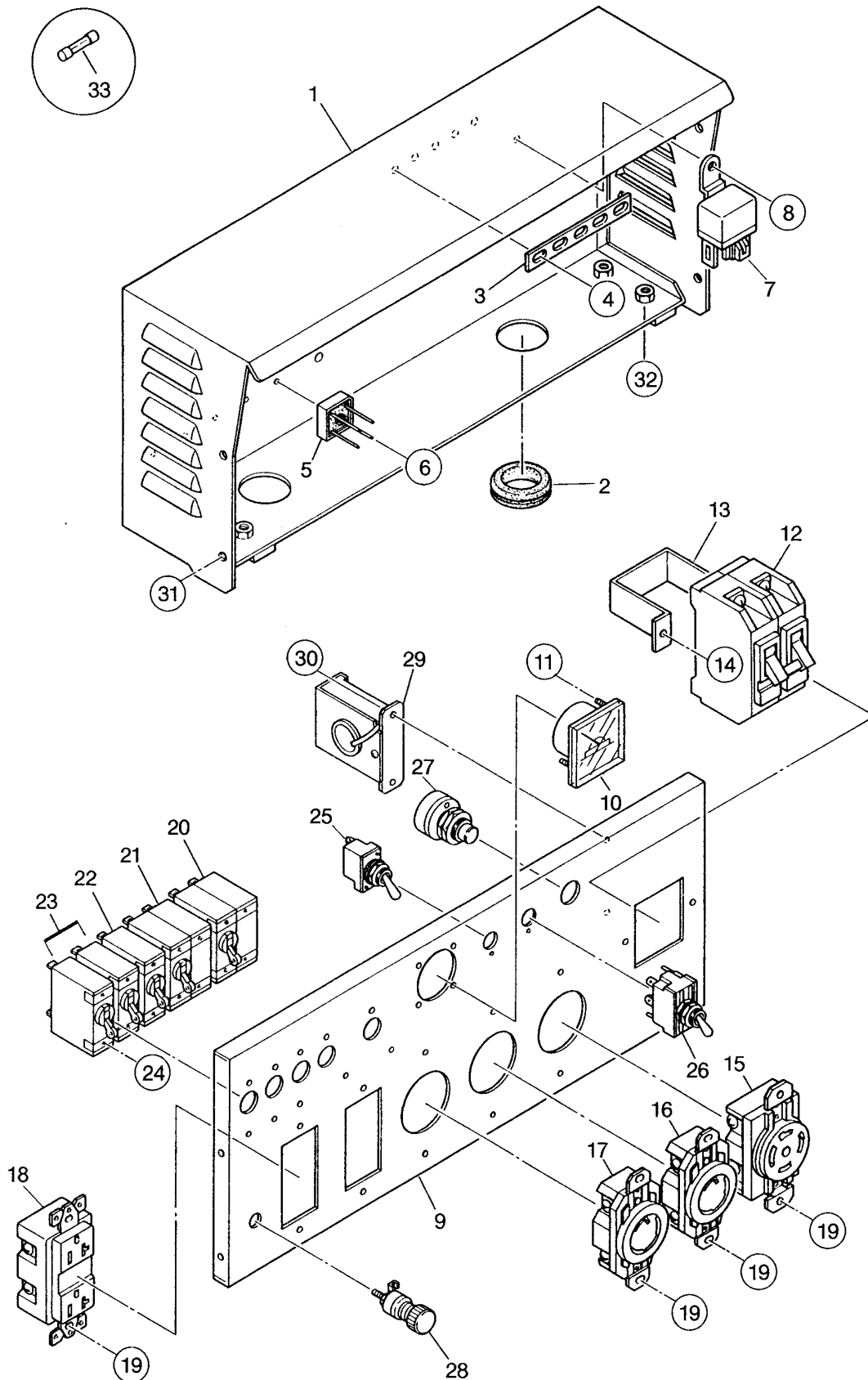

GA-9.7 HZ — CONTROL BOX ASSY.

CONTROL BOX ASSY.

<u>NO</u>	<u>PART NO</u>	<u>PART NAME</u>	<u>QTY.</u>	<u>REMARKS</u>
1	A6215000103	CONTROL BOX	1	
2	0601850102	GROMMET	2	G-3
3	8511864604	TERMINAL PLATE	1	
4	0016906020	HEX, HEAD BOLT	5	
5	0601823204	RECTIFIER	5	S5VB60
6	0027103020	MACHINE SCREW	5	
7	0601823754	RELAY	1	MPR-2TS DC12V
8	0027105016	MACHINE SCREW	1	
9	A6225000103	CONTROL PANEL	1	A65121 00002
10	0601800258	AC VOLTMETER	1	8283 120V/240V
11	0207003000	HEX, NUT	2	
12	0601807459	CIRCUIT BREAKER	1	KM52 2P 265V,35A
13	4341817004	BRACKET, CIRCUIT BREAK	1	
14	0027404010	MACHINE SCREW	2	
15	0601812529	RECEPTACLE	1	L14-30R 125/250V,30A,
16	0601811032	RECEPTACLE	1	L6-20R 250V,20A,
17	0601811031	RECEPTACLE	1	L5-30R125V,30A, REPLACES 0601811035
18	0601812597	RECEPTACLE	2	5-20R 120V,20A, REPLACES 0601812598
19	0021004010	MACHINE SCREW	10	
	0030004000	HEX. NUT	10	REPLACES 0207004000
20	0601806425	CIRCUIT BREAKER	1	CP32E/30N AC250V,30A
21	0601806036	CIRCUIT BREAKER	1	CP32E/20N AC250V,30A
22	0601806424	CIRCUIT BREAKER	1	CP31E/30N AC250V,30A
23	0601806423	CIRCUIT BREAKER	2	CP31E/20N AC250V,20A
24	0027103005	MACHINE SCREW	10	
25	0601830771	IDLE CONTROL SWITCH	1	S-1B
26	0601830796	OPERATION SWITCH	1	ET225N12
27	0663000010	START SWITCH	1	ST-403 REPLACES 0602100102
28	0601815109	GROUND TERMINAL	1	T-381
29	0601823853	IDLE CONTROL DEVICE	1	ND-80
30	0021004010	MACHINE SCREW	2	
31	0011305100	HEX. HEAD BOLT	4	REPLACES 0017105012
32	0016906020	HEX. HEAD BOLT	4	
32	0601802137	FUSE	2	10A AC250V

GA-9.7 HZ — PIPE FRAME ASSY.

PIPE FRAME ASSY.

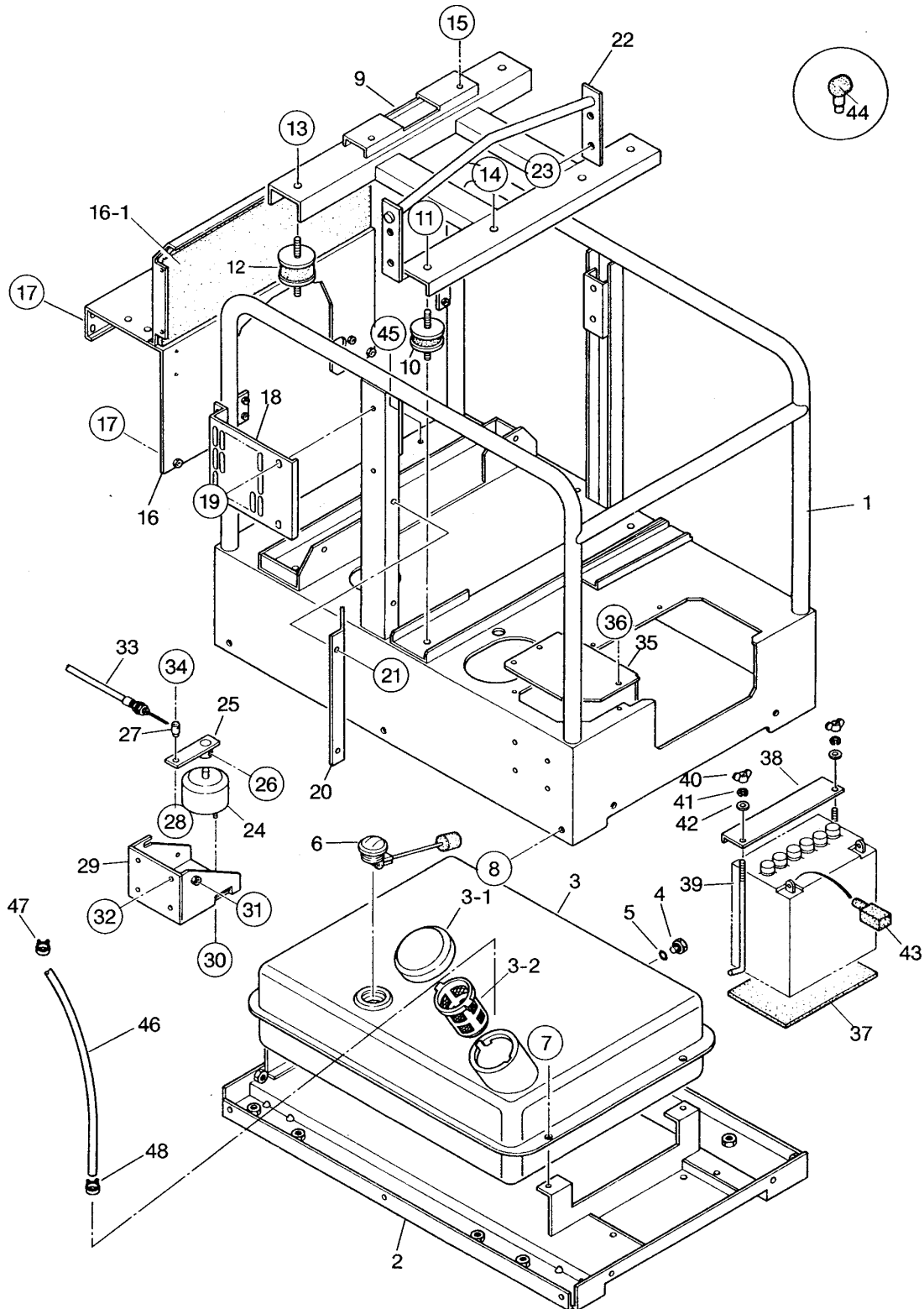

PIPE FRAME ASSY.

NO	PART NO	PART NAME	QTY.	REMARKS
1	A6418000402	PIPE FRAME	1	
2	A6415100003	FLOOR PANEL	1	
3	A6365000402	FUEL TANK	1	
3-1	0810105900	CAP, FUEL TANK	1	INCLUDES ITEM W/* REPLACES 0810105800
3-2*		FUEL FILTER	1	
4	3015530004	DRAIN PLUG	1	
5	0150200011	O RING	1	
6	0602125032	FUEL GAUGE	1	
7	011008020	HEX. HEAD BOLT	4	REPLACES 0017108020
8	011008020	HEX. HEAD BOLT	11	REPLACES 0017108020
9	A6418700103	BASE	1	
10	D9312600104	RUBBER SUSPENSION	2	
11	0207010000	HEX. NUT	2	
12	7605419004A	RUBBER SUSPENSION	2	REPLACES 7605419004
13	0207010000	HEX. NUT	2	
14	0010110045	HEX. HEAD BOLT	2	
	0207010000	HEX. NUT	2	
15	0012308030	HEX. HEAD BOLT	2	
16	A6425400303	BRACKET	1	
16-1	A6498200004	LINING	1	
17	0017106016	HEX, HEAD BOLT	8	
18	A6332300204	COVER	1	
19	0017106016	HEX. HEAD BOLT	4	
20	A6418400304	AIR GUIDE	1	
21	0017106016	HEX. HEAD BOLT	2	
22	A6435300003	HANGER	1	
23	0017110025	HEX. HEAD BOLT	4	
24	1622636103Z	ROTARY SOLENOID	1	REPLACES 1620150404
25	1992636004	ARM, SOLENOID	1	
26	011606025	HEX. HEAD BOLT	1	REPLACES 0010106025
	020106050	HEX. NUT	1	REPLACES 0030006000
27	A6356600404	WIRE STOPPER	1	
28	0017105010	HEX. HEAD BOLT	1	
29	A6359200503	BRACKET, SOLENOID	1	
30	0207006000	HEX. NUT	2	
31	0010106040	HEX. HEAD BOLT	1	
	020106050	HEX. NUT	1	REPLACES 0038706000
32	0017106016	HEX. HEAD BOLT	4	
33	A6356400303	THROTTLE WIRE	1	
34	0021005010	MACHINE SCREW	1	
35	A6356600304	COVER, SOLENOID	1	
36	0017106016	HEX. HEAD BOLT	4	
37	A6345200204	BATTERY SHEET	1	
38	D1343200204	BATTERY BAND	1	
39	0805082704	BATTERY BOLT	2	
40	0037806000	WING NUT	2	
41	0040006000	SPRING WASH	2	
42	952404470	PLAIN WASHER	2	REPLACES 0041206000
43	0602220600	TERMINAL CAP (RED)	1	
	0602220601	TERMINAL CAP (BLK)	1	
44	D1343200604	TERMINAL CAP	1	
45	0019206016	HEX. HEAD BOLT	1	
46	0605513143	HOSE	1	
47	0605515240	HOSE BAND	1	
48	0605515093	HOSE BAND	1	

NAMEPLATE ASSY.

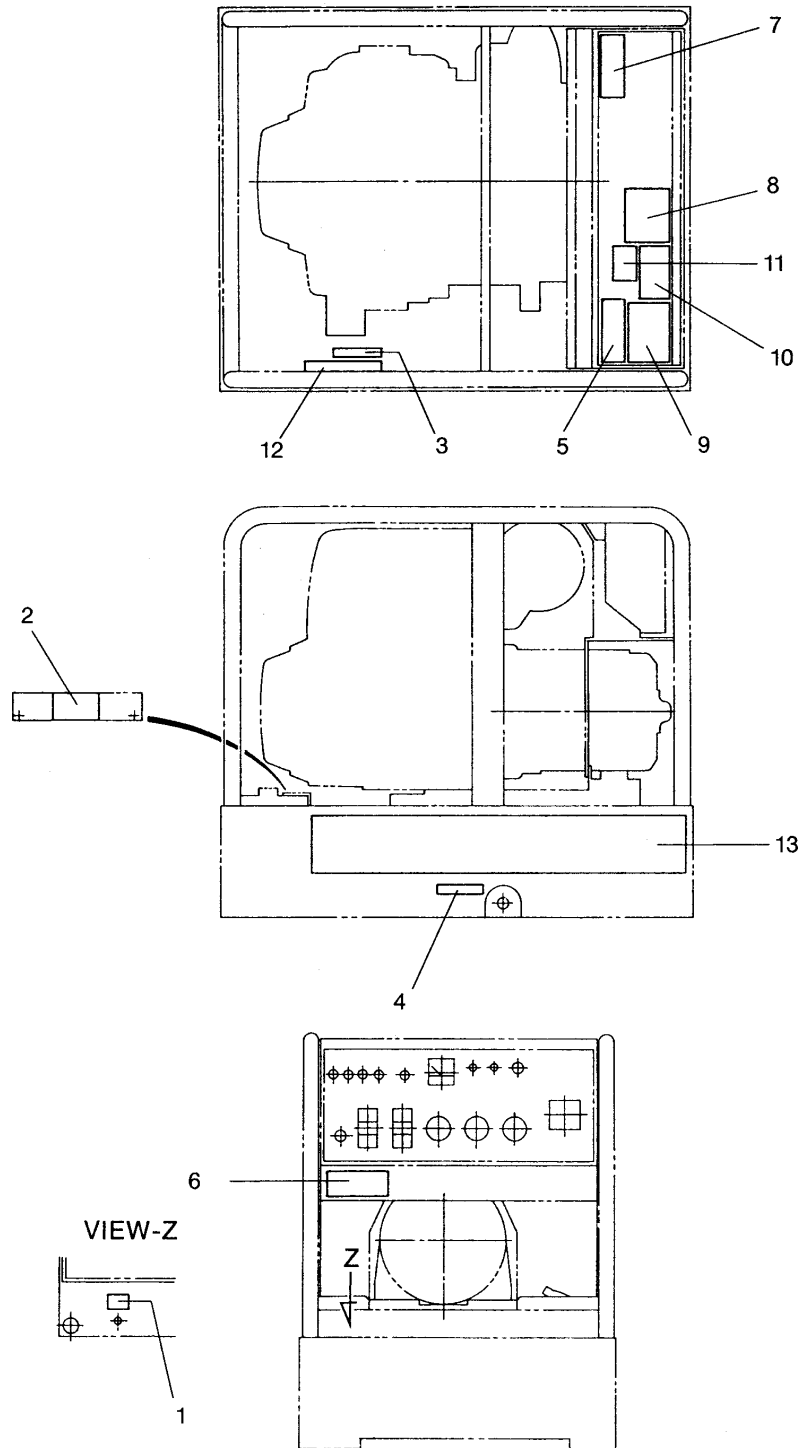

GA-9.7 HZ — NAMEPLATE ASSY.

NAMEPLATE ASSY.

<u>NO</u>	<u>PART NO</u>	<u>PART NAME</u>	<u>QTY.</u>	<u>REMARKS</u>
		NAME PLATE		ORDER FROM MULTIQUIP SERVICE DEPT. BY MODEL & SERIAL NUMBER
1	0800628504	DECAL; GROUND	1	S-1123
2	0800696604	DECAL; BATTERY	1	
3	1630645004	DECAL; OIL DRAIN	1	S-1403
4	7810680104	DECAL; FUEL DRAIN	1	S-3060
5	8700611804	DECAL; WARNING DANGEROUS	1	S-4984
6	8700611904	DECAL; DANGER ELECTRICAL	1	S-4985
7	B9504000304	DECAL; CAUTION HOT PARTS	1	B90400030
8	D2552000404	DECAL; OPERATING INSTRUCTIONS	1	D25200040B
9	0820610804	DECAL; CAUTION!	1	REPLACES 0820610304
10	0820610404	DECAL; WARNING!	1	
11	7900636004	DECAL; 3600RPM ONLY	1	
12	8700611524	DECAL; CAUTION OIL LEVEL GAUGE	1	
13	A6562100003	DECAL; MQ MULTIQUIP 9700	2	

SEE PAGE 7 FOR DECAL ILLUSTRATIONS.

HONDA GX610K1 ENGINE — CYLINDER HEAD ASSY.

CYLINDER HEAD ASSY.

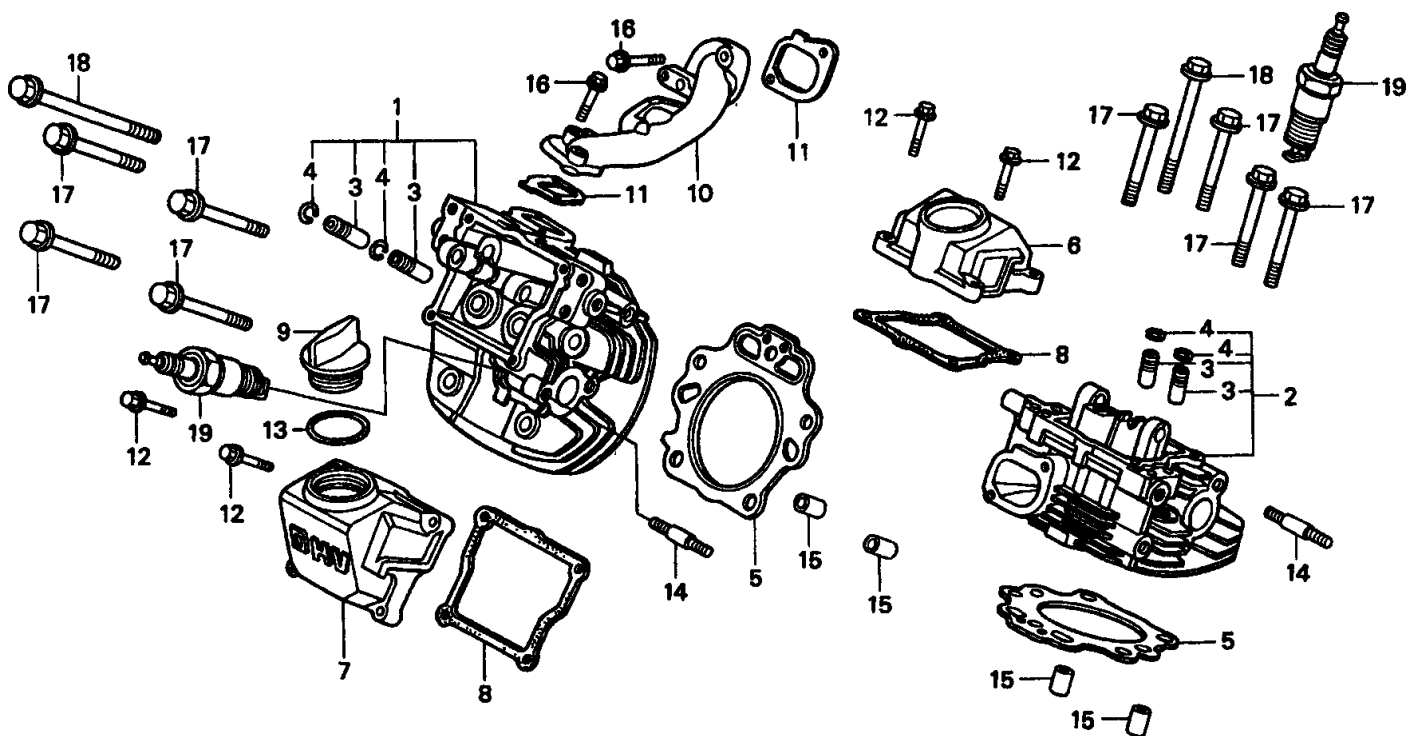

HONDA GX610K1 ENGINE — CYLINDER HEAD ASSY.

CYLINDER HEAD ASSY.

<u>NO</u>	<u>PART NO</u>	<u>PART NAME</u>	<u>QTY.</u>	<u>REMARKS</u>
1	12210ZJ1000	CYLINDER HEAD COMP., R.	1	INCLUDES ITEMS W/*
2	12220ZJ1U80	CYLINDER HEAD COMP., L.	1	INCLUDES ITEMS W/*
3*	12205ZE2305	GUIDE, EX. VALVE (OS)	4	
4*	12216ZE2300	CLIP, VALVE GUIDE	4	
5	12251ZJ1003	GASKET, CYLINDER HEAD	2	
6	12311ZJ1000	COVER, HEAD	1	
7	12314ZJ1000	COVER, HEAD FILLER	1	
8	12391ZJ1000	GASKET, HEAD COVER	2	
9	15611921000	CAP, OIL	1	
10	17101ZJ1000	MANIFOLD, IN.	1	
11	17151ZJ1003	GASKET, IN. MANIFOLD	2	
12	90121ZJ1000	BOLT, FLANGE (6X25) (CT200)	8	
13	91301805000	O-RING (26X2.7)	1	
14	92900080250B	BOLT, STUD (8X25)	4	
15	9430112200	PIN A, DOWEL (12X20)	4	
16	957010603200	BOLT, FLANGE (6X32)	4	
17	957011007500	BOLT, FLANGE (10X75)	8	
18	957011013000	BOLT, FLANGE (10X130)	2	
19	9807956846	SPARK PLUG (BPR6ES) (NGK)	2	

HONDA GX610K1 ENGINE — CYLINDER BARREL ASSY.

CYLINDER BARREL ASSY.

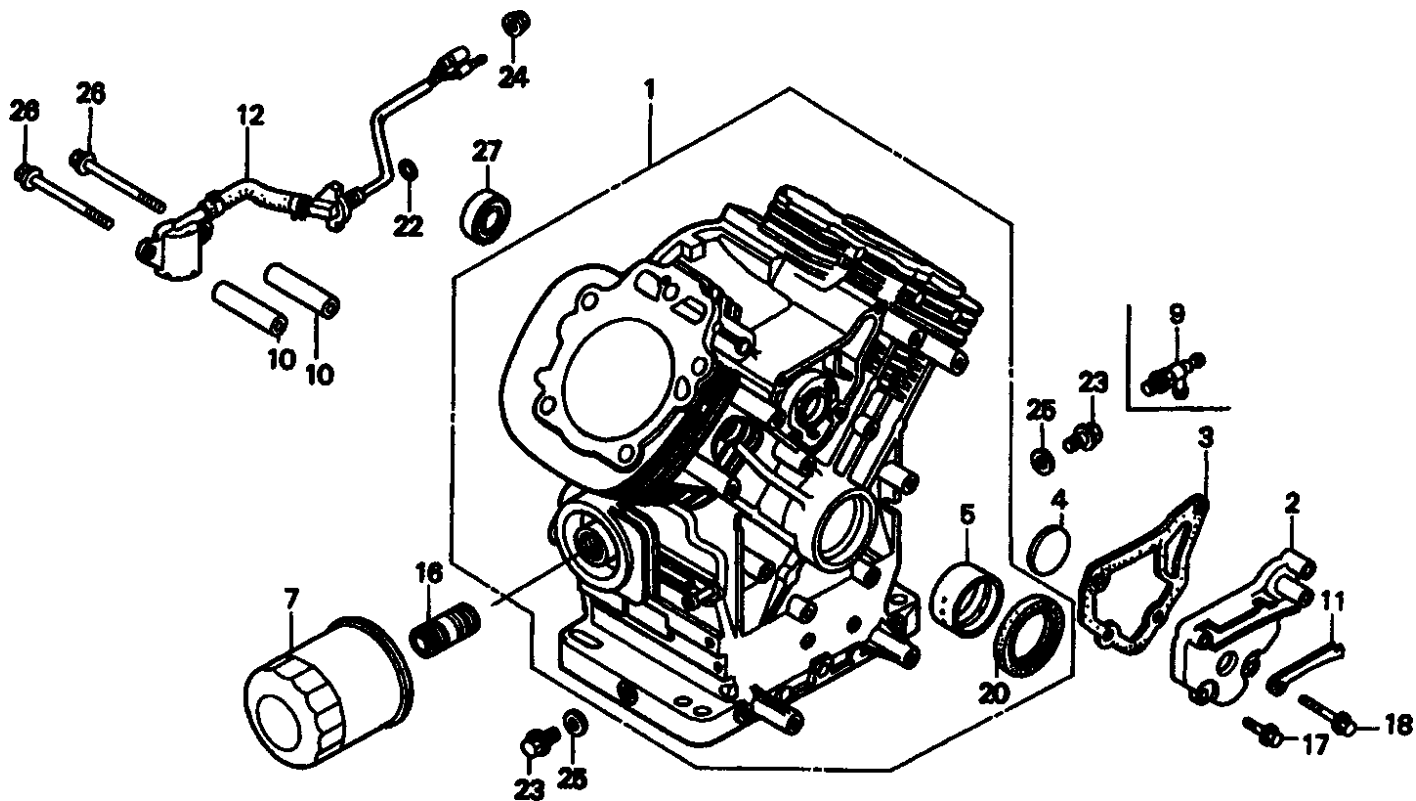

HONDA GX610K1 ENGINE — CYLINDER BARREL ASSY.

CYLINDER BARREL ASSY.

<u>NO</u>	<u>PART NO</u>	<u>PART NAME</u>	<u>QTY.</u>	<u>REMARKS</u>
1	12000ZJ1810	CYLINDER BARREL ASSY.	1	INCLUDES ITEMS W/*
2	12356ZJ1000	COVER, BREATHER	1	
3	12358ZJ1000	GASKET, BREATHER COVER	1	
4	12372ZE2300	VALVE, BREATHER	1	
5*	13321ZJ1000	BEARING A, MAIN (BLUE)	1	
	13322ZJ1000	BEARING B, MAIN (BLACK)	1	
	13323ZJ1000	BEARING C, MAIN (BROWN)	1	
7	15400PR3004	FILTER, OIL	1	
10	25523VD6010	COLLAR, FILTER SETTING	2	
11	31511ZJ1000	CLAMP, WIRE	1	
12	35480ZJ1812	SWITCH ASSY., OIL LEVEL	1	
15	90014ZE6000	BOLT, FLANGE (6X35)	3	
16	90018PN3000	HOLDER, OIL FILTER	1	
17	90029888000	BOLT, FLANGE (6X16)	2	
18	90031ZE1000	BOLT, FLANGE (6X32)	2	
20*	91201ZJ1003	OIL SEAL (38X58X11)	1	
22	91353671004	O-RING (14MM)	1	
23	9280014000	BOLT, DRAIN PLUG (14MM)	2	
24	9405010000	NUT, FLANGE (10MM)	1	
25	9410914000	WASHER, DRAIN PLUG (14MM)	2	
26	957010607509	BOLT, FLANGE (6X75)	2	
27	961406003010	BEARING, RADIAL BALL (6003)	1	

HONDA GX610K1 ENGINE — CRANKCASE COVER ASSY.

CRANKCASE COVER ASSY.

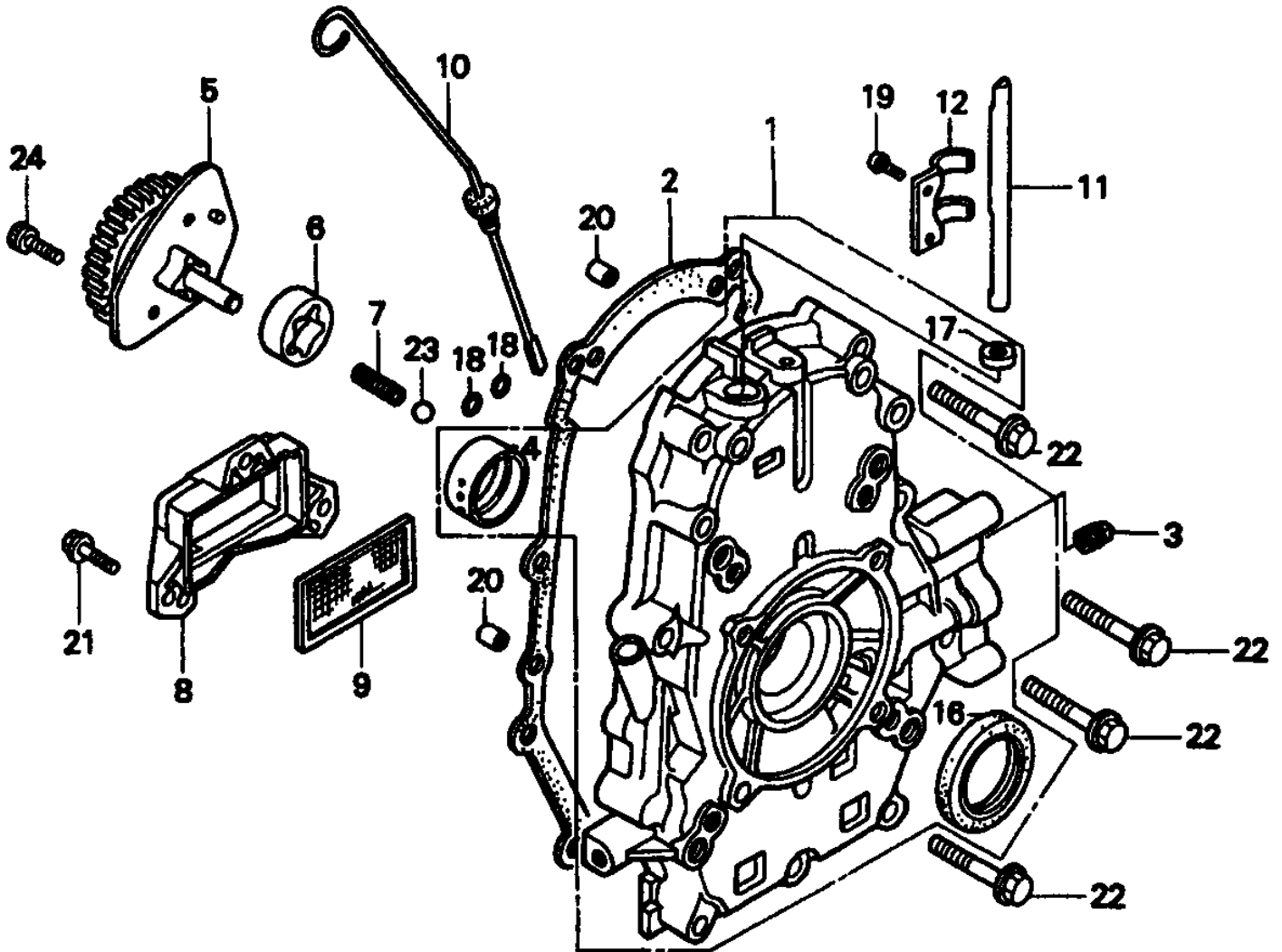

HONDA GX610K1 ENGINE — CRANKCASE COVER ASSY.

CRANKCASE COVER ASSY.

<u>NO</u>	<u>PART NO</u>	<u>PART NAME</u>	<u>QTY.</u>	<u>REMARKS</u>
1	11300ZJ1000	COVER ASSY., CRANKCASE	1	
2	11381ZJ1000	GASKET, CASE COVER	1	
3	12105ZAO701	BOLT, SEALING	1	
4	13321ZJ1000	BEARING A, MAIN (BLUE)	1	
	13322ZJ1000	BEARING B, MAIN (BLACK)	1	
	13323ZJ1000	BEARING C, MAIN (BROWN)	1	
5	15120ZJ1000	COVER ASSY., OIL PUMP	1	
6	15124ZJ1003	ROTOR, OIL PUMP (OUTER)	1	
7	15232ZJ1000	SPRING, RELIEF VALVE	1	
8	15348ZJ1000	COVER, OIL FILTER	1	
9	15427ZJ1000	SCREEN, OIL FILTER	1	
10	15655ZJ1000	DIPSTICK, OIL	1	
11	16541ZJ1000	SHAFT, GOVERNOR ARM	1	
12	16542ZJ1000	FORK, GOVERNOR	1	
16	91201ZJ1003	OIL SEAL (38X58X11)	1	
17	91259NM0000	OIL SEAL (10X16X4.5).....	1 REPLACES 91206333003
18	91302MB6830	O-RING (13X3.0)	2	
19	93500050100A	SCREW, PAN (5X10)	2	
20	9430108140	PIN A, DOWEL (8X14)	2	
21	957010602000	BOLT, FLANGE (6X20)	3	
22	957010805000	BOLT, FLANGE (8X50)	9	
23	9621112000	BALL, STEEL (#12) (3/8)	1	
24	966000601600	BOLT, SOCKET (6X16)	2	

HONDA GX610K1 ENGINE — CRANKSHAFT ASSY.

CRANKSHAFT ASSY.

DETAIL -A-

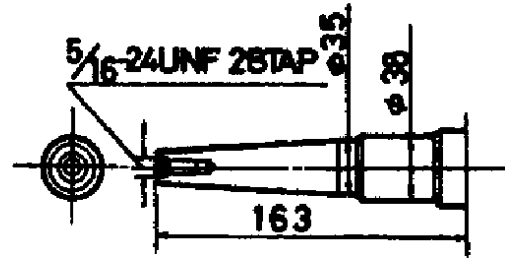
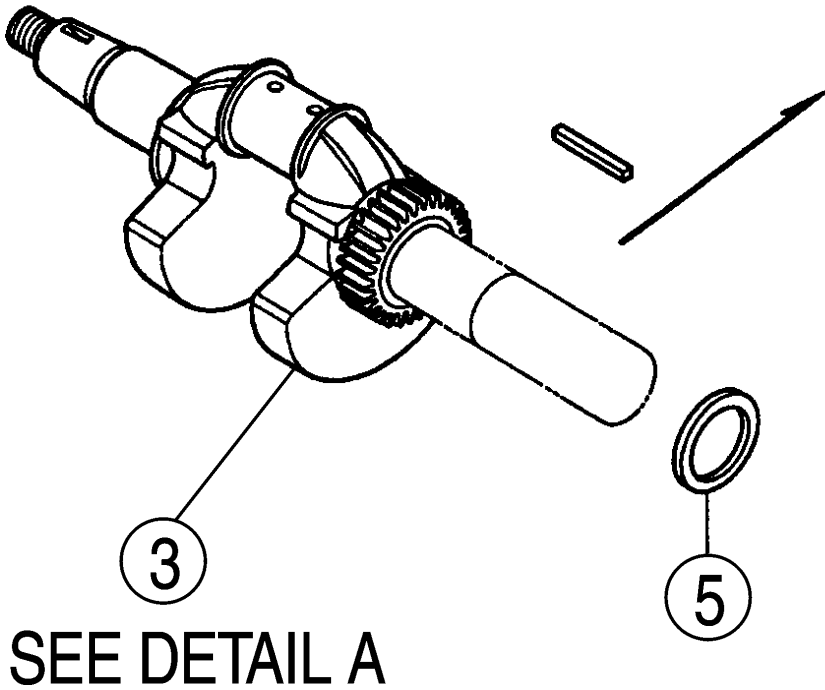

HONDA GX610K1 ENGINE — CRANKSHAFT ASSY.

CRANKSHAFT ASSY.

<u>NO</u>	<u>PART NO</u>	<u>PART NAME</u>	<u>QTY.</u>	<u>REMARKS</u>
3	13310ZJ0880	CRANKSHAFT COMP.	1	
5	90401ZJ1000	WASHER, CRANKSHAFT THRUST	1	

HONDA GX610K1 ENGINE — PISTON ASSY.

PISTON ASSY.

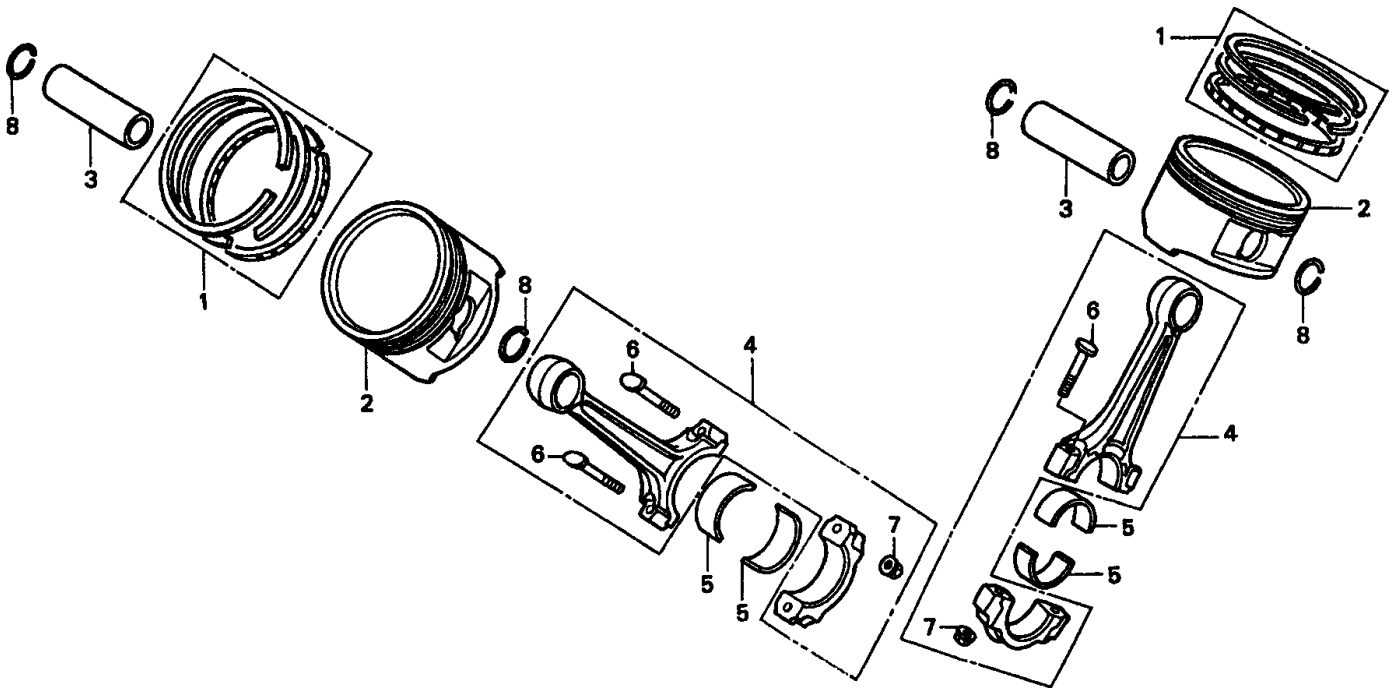

HONDA GX610K1 ENGINE — PISTON ASSY.

PISTON ASSY.

<u>NO</u>	<u>PART NO</u>	<u>PART NAME</u>	<u>QTY.</u>	<u>REMARKS</u>
1	13010ZE8601	RING SET, PISTON (STD)	2	
	13011ZE8601	RING SET, PISTON (0.25)	2	
	13012ZE8601	RING SET, PISTON (0.50)	2	
	13013ZE8601	RING SET, PISTON (0.75)	2	
2	13101ZJ1000	PISTON	2	
	13102ZJ1000	PISTON (0.25)	2	
	13103ZJ1000	PISTON (0.50)	2	
	13104ZJ1000	PISTON (0.75)	2	
3	13111ZJ1000	PIN, PISTON	2	
4	13210ZJ1000	ROD SET, CONNECTING	2	INCLUDES ITEM W/★
5	13211ZJ1003	BEARING A, CONNECTING ROD (BLUE)	4	
	13212ZJ1003	BEARING B, CONNECTING ROD (BLACK)	4	
	13213ZJ1003	BEARING C, CONNECTING ROD (BROWN)	4	
	13214ZJ1003	BEARING D, CONNECTING ROD (GREEN)	4	
	13215ZJ1003	BEARING E, CONNECTING ROD	4	
	13216ZJ1003	BEARING F CONNECTING ROD	4	
	13217ZJ1003	BEARING G CONNECTING ROD	4	
6★	13213ML0000	BOLT, CONNECTING ROD	4	
7★	13215KM3000	NUT, CONNECTING ROD	4	
8	9460118000	CLIP, PISTON PIN (18MM)	4	

HONDA GX610K1 ENGINE — CAMSHAFT ASSY.

CAMSHAFT ASSY.

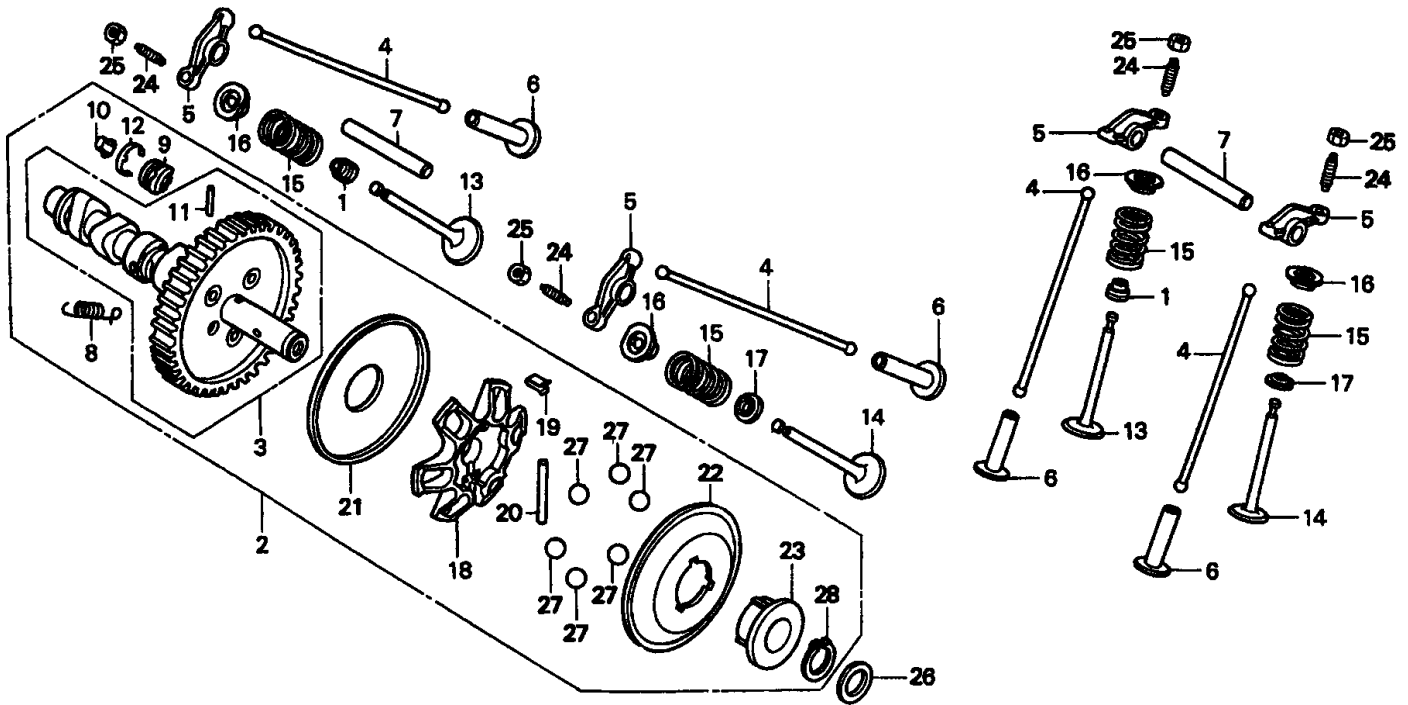

HONDA GX610K1 ENGINE — CAMSHAFT ASSY.

CAMSHAFT ASSY.

<u>NO</u>	<u>PART NO</u>	<u>PART NAME</u>	<u>QTY.</u>	<u>REMARKS</u>
1	12209ZE8003	SEAL, VALVE STEM	2	
2	14100ZJ1801	CAMSHAFT ASSY.	1	INCLUDES ITEM W/*
3*	14110ZJ1801	CAMSHAFT COMP.	1	INCLUDES ITEM W/#
4	14410ZJ1000	ROD, PUSH	4	
5	14431ZJ1000	ARM, VALVE ROCKER	4	
6	14441ZE2000	LIFTER, VALVE	4	
7	14461ZJ1000	SHAFT, ROCKER ARM	2	
8*	14568ZJ1800	SPRING, WEIGHT RETURN	1	
9*	14569ZJ1801	HOLDER, DECOMPRESSION PIN	2	
10*	14576ZJ1801	PIN A, DECOMPRESSION (7.85)	2	
	14577ZJ1801	PIN B, DECOMPRESSION (7.95)	2	REPLACES 14577ZJ1800
	14578ZJ1800	PIN C, DECOMPRESSION (8.05)	2	REPLACES 14578ZJ1800
	14579ZJ1800	PIN D, DECOMPRESSION (8.15)	2	
	14580ZJ1800	PIN E, DECOMPRESSION (8.25)	2	
11*#	14581ZJ1801	ROD, DECOMPRESSION	1	
12*	14586ZJ1800	SPRING, DECOMPRESSION PIN HOLDER	2	
13	14711ZJ1000	VALVE, INLET	2	
14	14721ZJ1000	VALVE, EX.	2	
15	14751ZE2003	SPRING VALVE	4	
16	14771ZE2000	RETAINER, IN. VALVE SPRING	4	
17	14775ZE2010	SEAT, VALVE SPRING	2	
18*	16512ZJ1000	HOLDER, GOVERNOR WEIGHT	1	
19*	16522ZJ1000	PLATE, GOVERNOR WEIGHT HOLDER	1	
20*	16523ZJ1000	PIN, GOVERNOR WEIGHT HOLDER	1	
21*	16524ZJ1000	PLATE, GOVERNOR (LOWER)	1	
22*	16529ZJ1000	PLATE, GOVERNOR SLIDER	1	
23*	16531ZJ1003	SLIDER, GOVERNOR	1	
24	90012415000	SCREW, TAPPET ADJ.	4	
25	90206250000	NUT, TAPPET ADJ.	4	
26	90446357000	WASHER, THRUST (17.2MM)	1	
27*	90901ZJ1003	BALL, STEEL (18)	6	
28*	9451017000	CIRCLIP (OUTER) (17MM)	1	

HONDA GX610K1 ENGINE — RECOIL STARTER ASSY.

RECOIL STARTER ASSY.

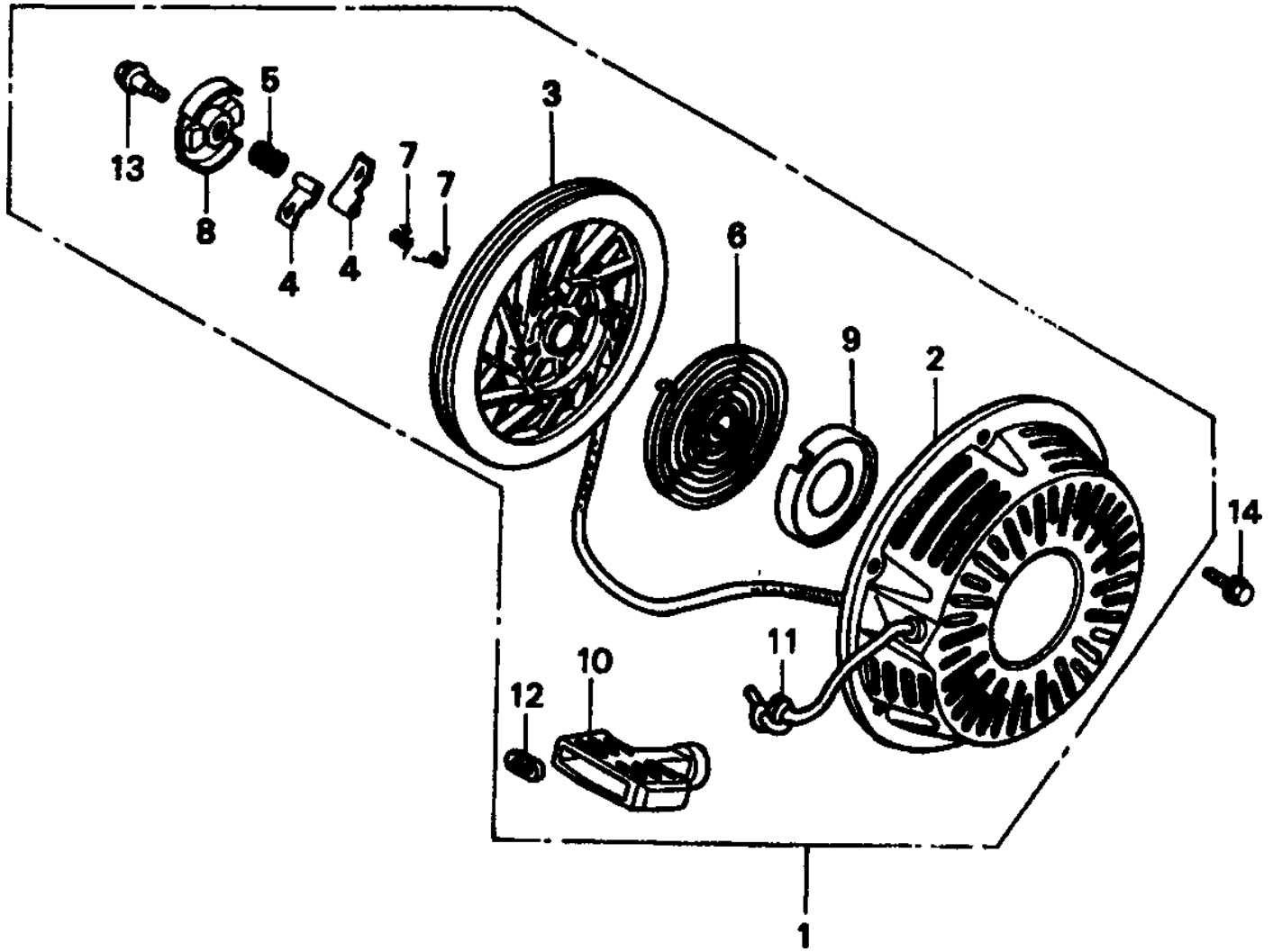

HONDA GX610K1 ENGINE — RECOIL STARTER ASSY.

RECOIL STARTER ASSY.

<u>NO</u>	<u>PART NO</u>	<u>PART NAME</u>	<u>QTY.</u>	<u>REMARKS</u>
1	28400ZE3W01ZA	STARTER ASSY., RECOIL R8 (BRT. RED)	1	INCLUDES ITEMS W/*
2*	28410ZE3W01ZA	CASE COMP. RECOIL STARTER R8 (BRT RED)	1	
3*	28421ZE3W01	PULLEY, RECOIL STARTER	1	
4*	28422ZE2W01	RATCHET STARTER	2	
5*	28441ZE2W01	SPRING, FRICTION	1	
6*	28442ZE2W01	SPRING, STARTER RETURN	1	
7*	28443ZE2W01	SPRING, RATCHET	2	
8*	28444ZE2W01	RETAINER, SPRING	1	
9*	28445ZE2W01	HOLDER, SPRING	1	
10*	28461ZE2W01	GRIP, STARTER	1	
11*	28462ZH8003	ROPE, RECOIL STARTER	1 REPLACES 28462ZE3W01
12*	28469ZE2W01	GRIP, REINFORCEMENT	1	
13*	90004ZE2W01	SCREW, CENTER	1	
14	957010600800	BOLT, FLANGE (6X8)	3	

HONDA GX610K1 ENGINE — FAN COVER ASSY.

FAN COVER ASSY.

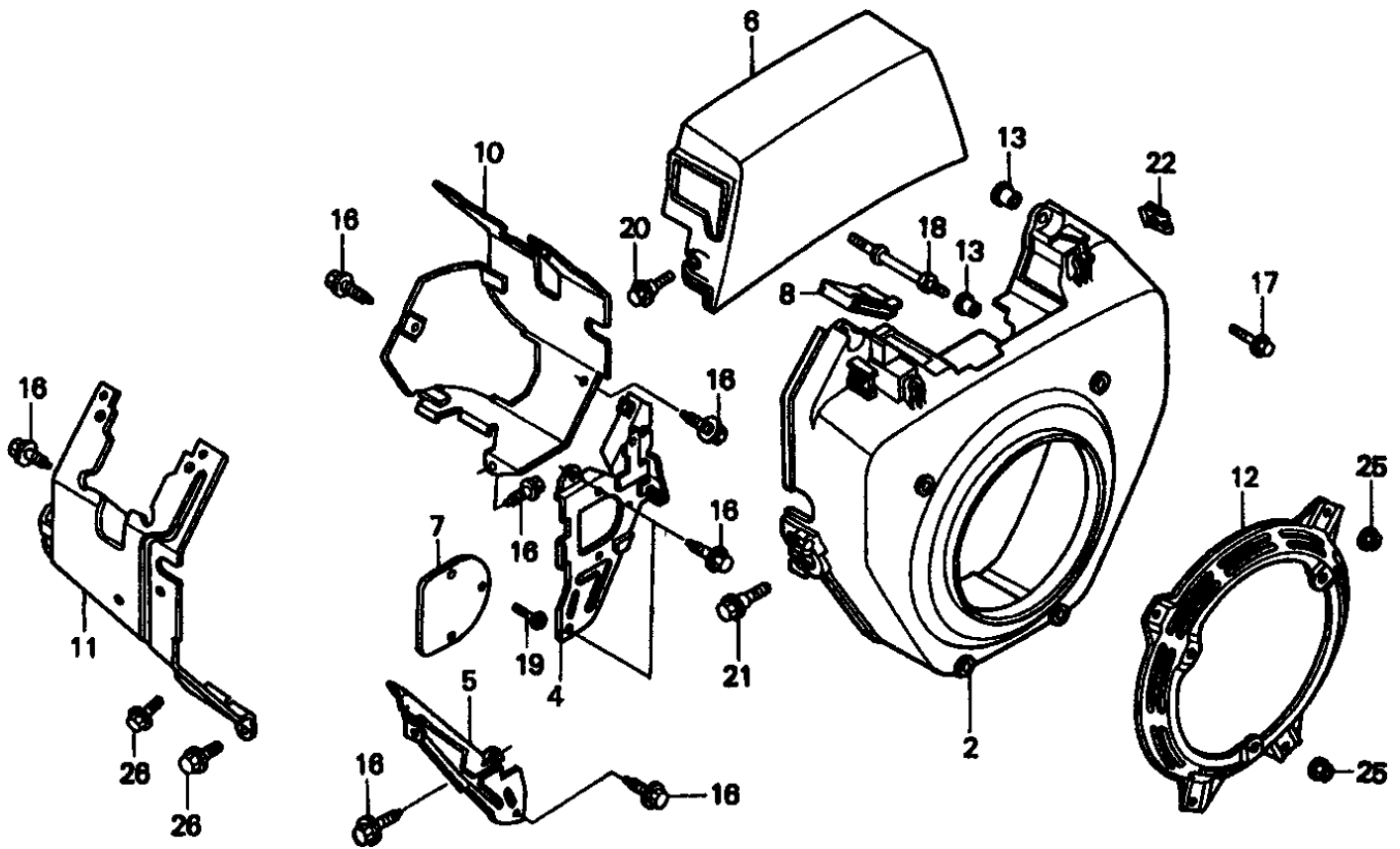

HONDA GX610K1 ENGINE — FAN COVER ASSY.

FAN COVER ASSY.

<u>NO</u>	<u>PART NO</u>	<u>PART NAME</u>	<u>QTY.</u>	<u>REMARKS</u>
2	19611ZJ1800ZB	COVER, FAN R8 (RECOIL STARTER)(BRT.RED)	1	
4	19612ZJ1000	PLATE, R. SIDE	1	
5	19614ZJ1000	PLATE, L. SIDE	1	
6	19615ZJ1000	HOOD FAN COVER	1	
7	19617ZJ4000	COVER, R. SIDE PLATE	1	
10	19631ZJ1000	SHROUD, R.	1	
11	19632ZJ1000	SHROUD, L.	1	
12	28405ZJ1801ZB	SPACER, RECOIL START MOUNT R8 (BRT RED))	1	
13	33713GC2000	COLLAR B,TAILLIGHT	6	
16	90013883000	BOLT, FLANGE (6X12)	8	
17	90018ZE1000	BOLT, FLANGE (6X23)	2	
18	90042ZJ1000	BOLT, STUD (6X75)	4	
19	90055ZE1000	SCREW, TAPPING (4X6)	3	
20	90104GF6000	BOLT, FLANGE (6X20)	2	
21	90113GE4000	BOLT, FLANGE (6MM) (BLACK)	2	
24	90683SD9781	CLIP (20MM)	1	
25	9405006000	NUT, FLANGE (6MM)	4	
26	957010600800	BOLT, FLANGE (6X8)	2	

HONDA GX610K1 ENGINE — CARBURETOR ASSY.

CARBURETOR ASSY.

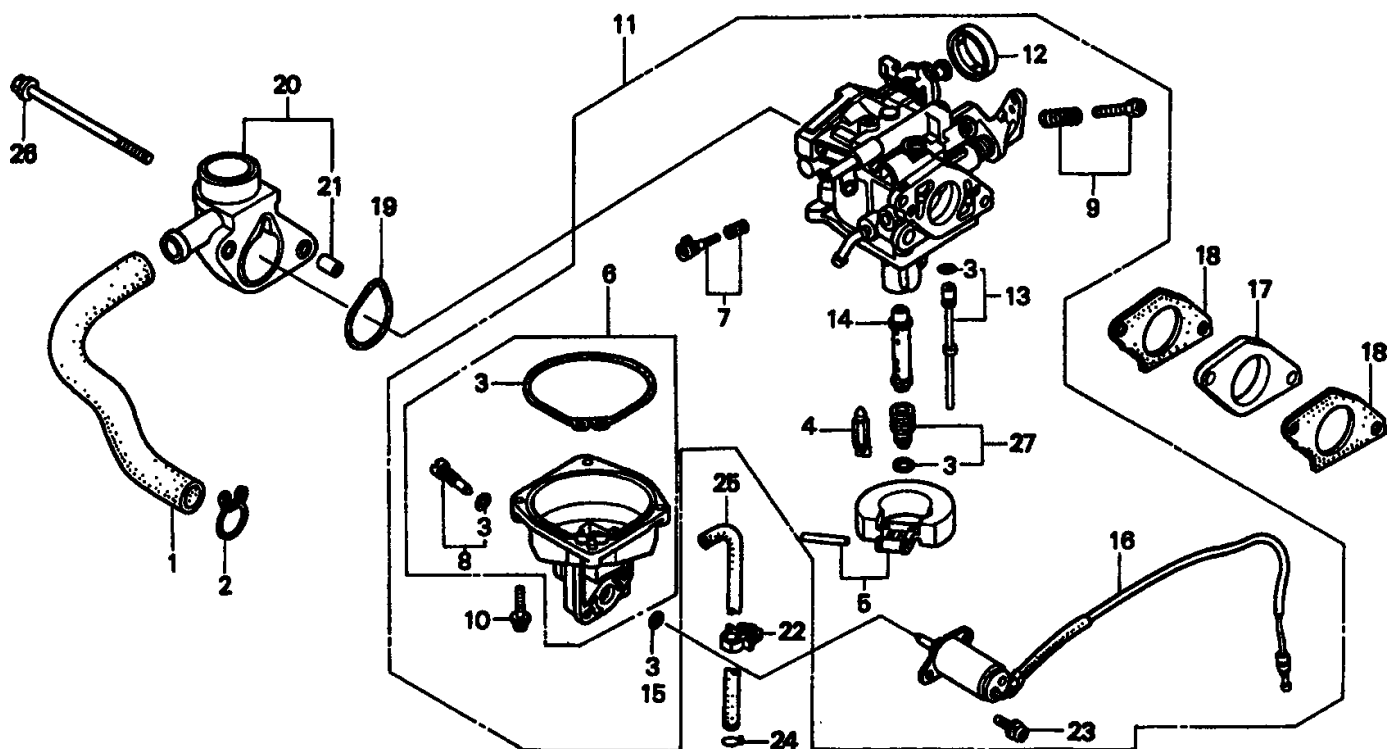

HONDA GX610K1 ENGINE — CARBURETOR ASSY.

CARBURETOR ASSY.

<u>NO</u>	<u>PART NO</u>	<u>PART NAME</u>	<u>QTY.</u>	<u>REMARKS</u>
1	12357ZJ1000	TUBE, BREATHER	1	
2	15772551000	CLIP, BREATHER TUBE	1	
3*#	16010ZG8000	GASKET SET	1	
4*	16011382004	VALVE SET, FLOAT	1	REPLACES 16011GK0891
5*	16013ZV4005	FLOAT SET	1	
6*	16015ZJ1000	CHAMBER SET, FLOAT	1	INCLUDES ITEMS W/#
7	16016ZJ1010	SCREW SET	1	
8*#	16024124760	SCREW SET,DRAIN	1	
9*	16028ZG8000	SCREW SET	1	
10*	16081ZV4650	SCREW-WASHER	4	
11	16100ZJ0892	CARBURETOR ASSY. (BG21E B)	1	INCLUDES ITEMS W/*
12*	16148141881	CAP, CHOKE LEVER DUST	1	
13*	16151ZJ0020	JET SET (#60)	1	
14*	16166ZJ1010	NOZZLE, MAIN	1	REPLACES 16166ZJ0000
15*	16178548004	O-RING (5.8X1.9)	1	
16*	16200ZJ1003	VALVE ASSY., SOLENOID	1	
17	16211ZJ1000	INSULATOR, CARBURETOR	1	
18	16221ZG8000	GASKET, CARBURETOR	2	
19	17228ZG8003	GASKET, AIR CLEANER	1	
20	17410ZJ1000	ELBOW COMP., AIR CLEANER	1	INCLUDES ITEMS W/+
21+	19024ZA0000	COLLAR, DISTANCE	2	
22	90682959661	CLIP B, CABLE	1	
23*	938920501218	SCREW-WASHER (5X12)	2	
24	9500202080	CLIP, TUBE (B8)	1	
25	950054546020	BULK HOSE, VAC (4.5X460)	1	
26	958010610508	BOLT, FLANGE (6X105)	2	
27*	99201ZG80880	JET SET, MAIN (#88)	1	
	99201ZG80820	JET SET, MAIN (#82 HIGH ALTITUDE)	1	
	99201ZG80850	JET SET, MAIN (#85 HIGH ALTITUDE)	1	

HONDA GX610K1 ENGINE — AIR CLEANER ASSY.

AIR CLEANER ASSY.

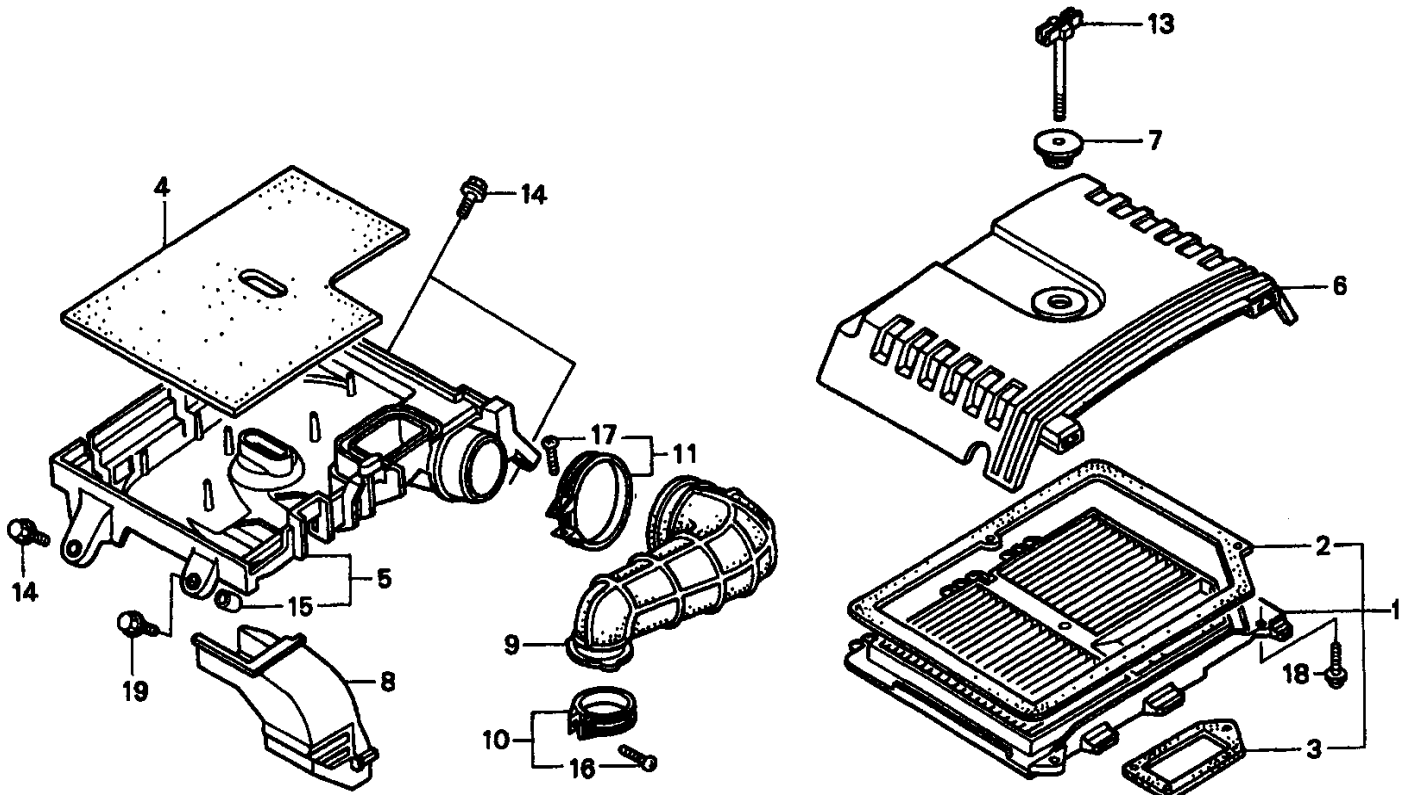

HONDA GX610K1 ENGINE — AIR CLEANER ASSY.

AIR CLEANER ASSY.

NO	PART NO	PART NAME	QTY.	REMARKS
1	17010ZJ1000	ELEMENT SET, AIR CLEANER	1	INCLUDES ITEMS W/*
2*	17216ZJ1000	GASKET A, ELEMENT	1	
3*	17217ZJ1000	GASKET B, ELEMENT	1	
4	17218ZJ1000	FILTER (OUTER)	1	
5	17220ZJ1000	HOUSING COMP., AIR CLEANER	1	
6	17231ZJ1000	COVER, AIR CLEANER	1	
7	17232ZJ1000	GROMMET, AIR CLEANER	1	
8	17237ZJ1000	HOSE, AIR CLEANER	1	
9	17251ZJ1000	TUBE, AIR CLEANER CONN.	1	
10	17255758000	BAND, AIR CLEANER CONN. TUBE	1	
11	17257HB3000	BAND, AIR CLEANER (B)	1	
13	90017ZJ1000	BOLT, AIR CLEANER	1	
14	90018ZE1000	BOLT, FLANGE (6X23)	3	
15	90120102000	COLLAR, AIR CLEANER HOUSING	4	
16	93500040200A	SCREW, PAN (4X20)	1	
17	93500040250G	SCREW, PAN (4X25)	1	
18	938910501608	SCREW, WASHER	2	
19	957000601800	BOLT, FLANGE (6X18)	1	REPLACES 957010601800

HONDA GX610K1 ENGINE — MUFFLER ASSY.

MUFFLER ASSY.

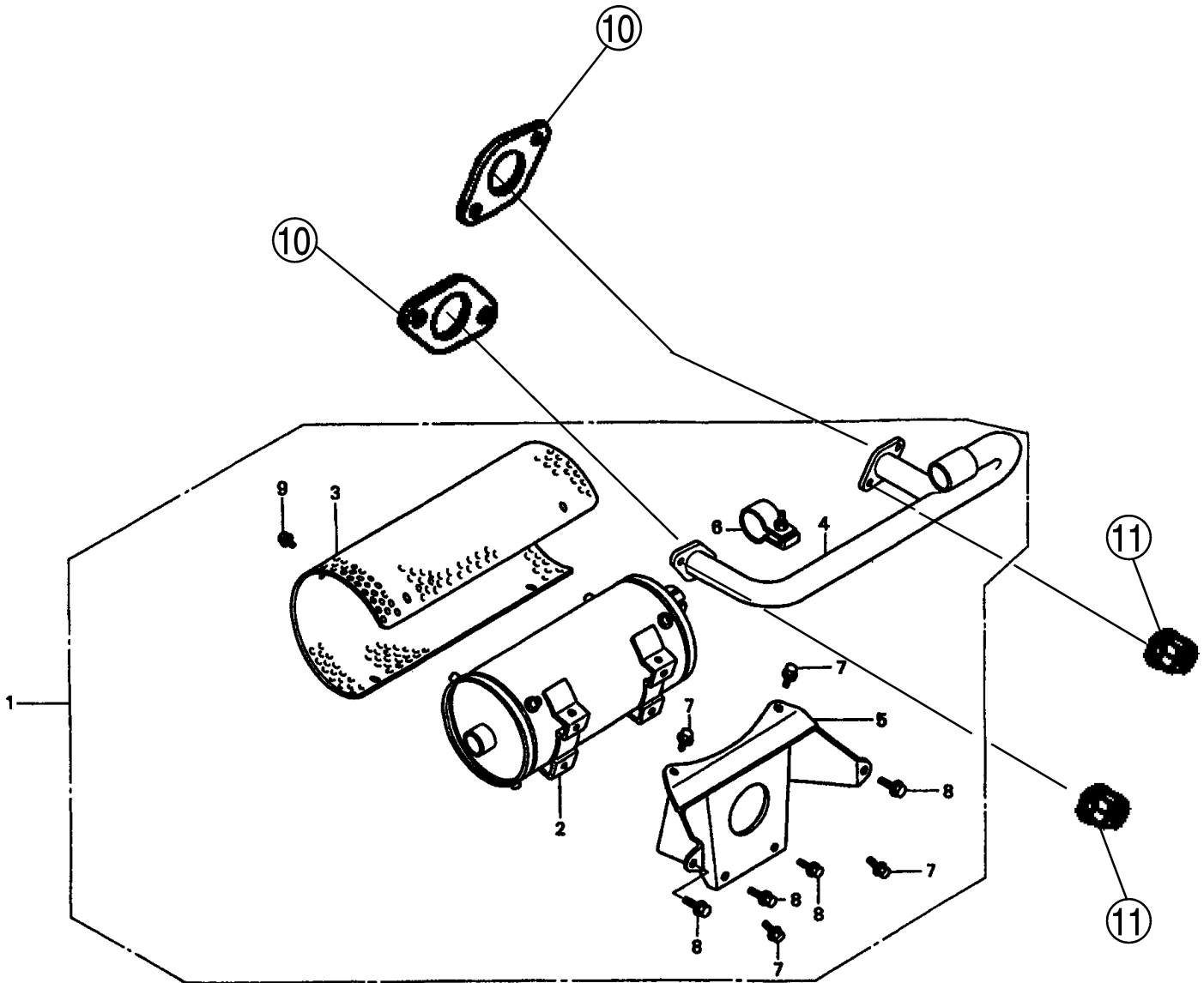

HONDA GX610K1 ENGINE — MUFFLER ASSY.

MUFFLER ASSY.

<u>NO</u>	<u>PART NO</u>	<u>PART NAME</u>	<u>QTY.</u>	<u>REMARKS</u>
1		MUFFLER KIT	1	NOT AVAILABLE, SEE COMPONENTS
2	18310ZJ1000	MUFFLER COMP.	1 18310ZJ1003
3	18321ZJ1000	PROTECTOR,MUFFLER	1 18321ZJ1003
4	18330ZJ1601	PIPE COMP., EX.	1	
5	18333ZJ1000	STAY, MUFFLER	1 18338ZJ1003
6	18396ZJ1003	BAND ASSY.	1	
7	957010600800	BOLT, FLANGE (6X8)	6	
8	957010801400	BOLT, FLANGE (8X14)	4	
9	957010802000	BOLT, FLANGE (8X20)	4	
10	18333ZJ1000	GASKET,EX,PIPE	2	
11	99405008000	NUT,FLANGE(8mm)	4	

HONDA GX610K1 ENGINE — FUEL PUMP ASSY.

FUEL PUMP ASSY.

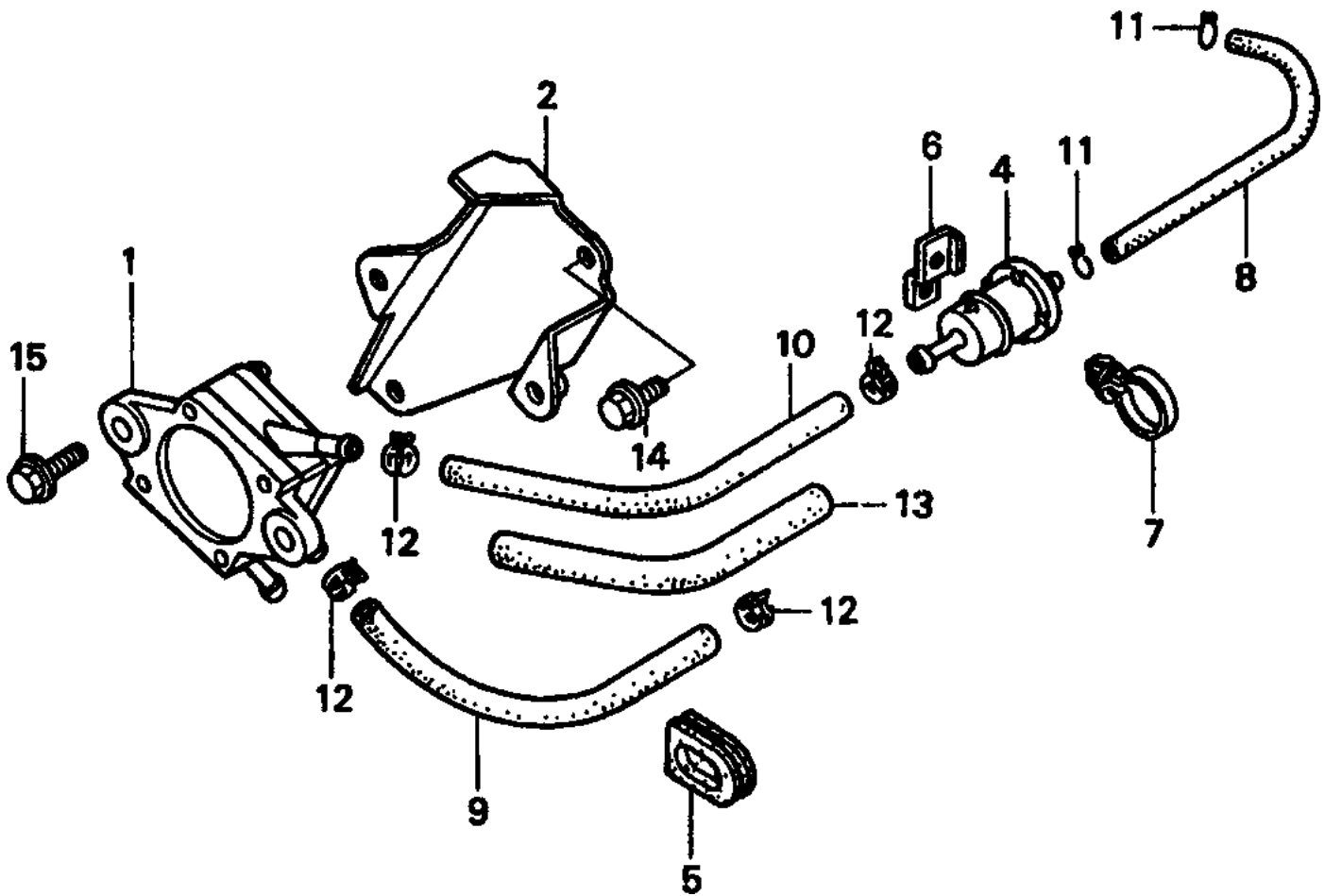

HONDA GX610K1 ENGINE — FUEL PUMP ASSY.

FUEL PUMP ASSY.

<u>NO</u>	<u>PART NO</u>	<u>PART NAME</u>	<u>QTY.</u>	<u>REMARKS</u>
1	16700ZJ1003	PUMP ASSY., FUEL	1	
2	16711ZJ1800	STAY, FUEL PUMP	1	
4	16910ZE8015	STRAINER COMP., FUEL	1	
5	19905ZA8701	GROMMET, WIRE	1	
6	35806752630	BASE, CLIP	1	
7	90617SA0003	CLIP, WIRE HARNESS	1	
8	950014511040	BULK HOSE, FUEL (4.5X110)	1	
9	950015519540	BULK HOSE, FUEL (5.5X195)	1	
10	950015521540	BULK HOSE, FUEL (5.5X215)	1	
11	9500202080	CLIP, TUBE (B8)	2	
12	950024105008	CLIP, TUBE (10.5MM)	4	
13	950033601620	TUBE, VINYL (11X13X160)	1	
14	957010600800	BOLT, FLANGE (6X8)	2	
15	957010601400	BOLT, FLANGE (6X14)	2	

HONDA GX610K1 ENGINE — FLYWHEEL ASSY.

FLYWHEEL ASSY.

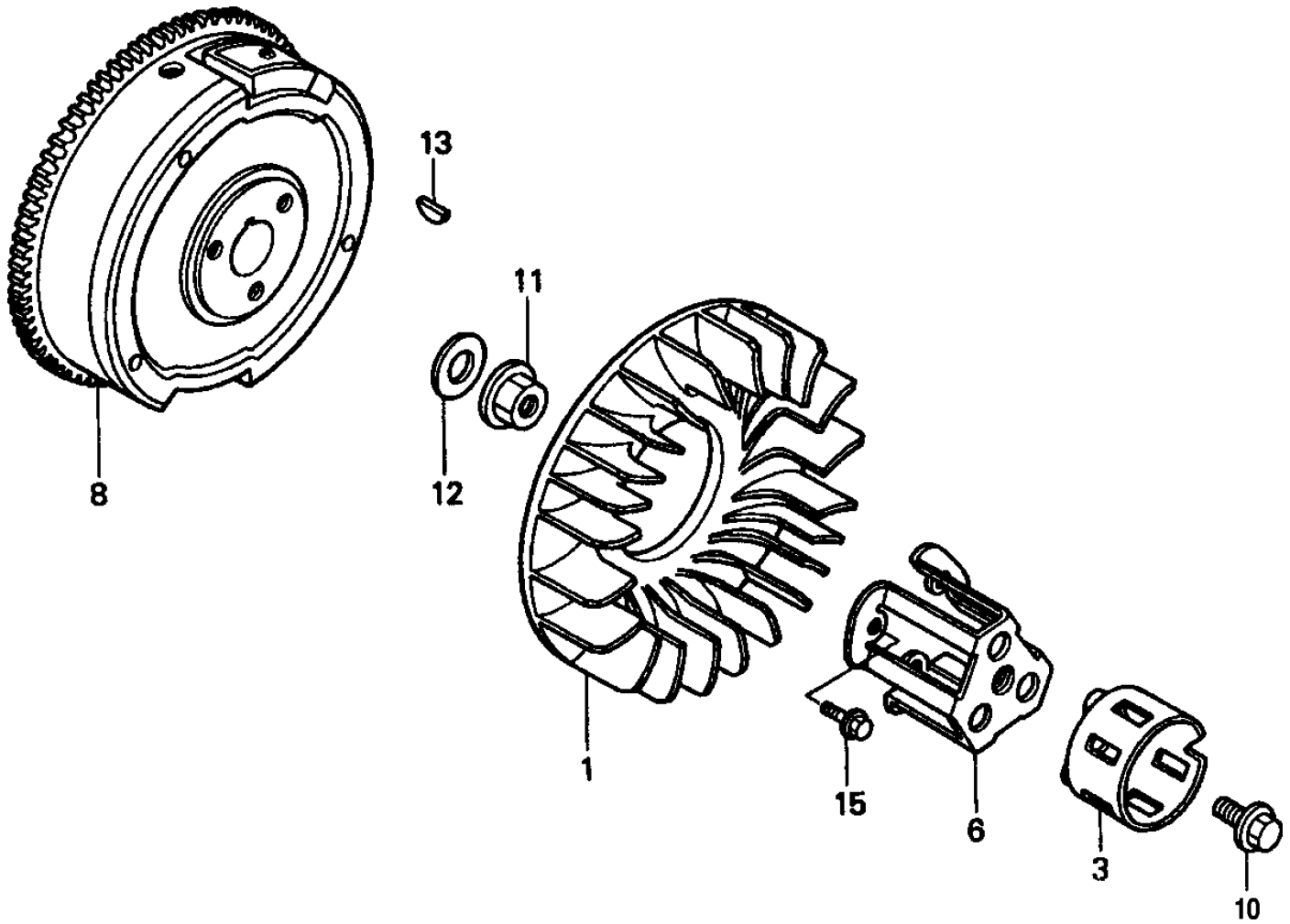

HONDA GX610K1 ENGINE — FLYWHEEL ASSY.

FLYWHEEL ASSY.

<u>NO</u>	<u>PART NO</u>	<u>PART NAME</u>	<u>QTY.</u>	<u>REMARKS</u>
1	19511ZJ1000	FAN, COOLING	1	
3	28451ZJ1801	PULLEY, STARTER	1	
6	28453ZJ1801	SPACER, STARTER PULLEY MT.	1	
8	31110ZJ1811	FLYWHEEL COMP.	1	
10	90013ZJ1800	BOLT, UBS (12X28)	1	
11	90201ZG3000	NUT, FLANGE (20MM)	1	
12	90401ZG3000	WASHER (20MM)	1	
13	90741ZE2000	KEY, SPECIAL WOODRUFF (25X18)	1	
15	957010801600	BOLT, FLANGE (8X16)	3	

HONDA GX610K1 ENGINE — IGNITION COIL ASSY.

IGNITION COIL ASSY.

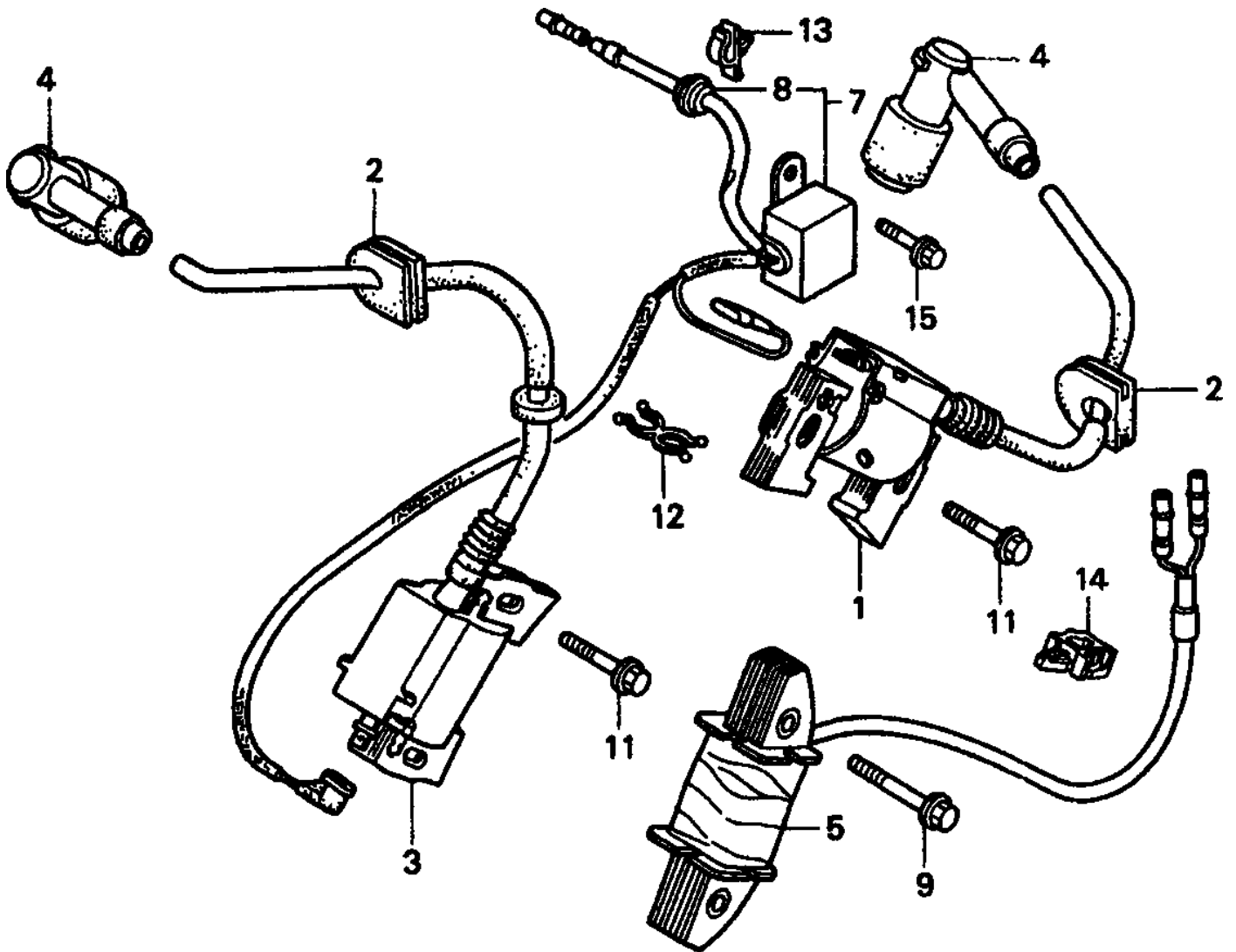

HONDA GX610K1 ENGINE — IGNITION COIL ASSY.

IGNITION COIL ASSY.

<u>NO</u>	<u>PART NO</u>	<u>PART NAME</u>	<u>QTY.</u>	<u>REMARKS</u>
1	30500ZJ1013	COIL ASSY., R. IGNITION	1	
2	30518ZJ1000	GROMMET, IGNITION WIRE	2	
3	30550ZJ1013	COIL ASSY., L. IGNITION	1	
4	30700ZJ1003	CAP ASSY., NOISE SUPPRESSER	2	
5	31630ZJ1003	COIL ASSY., CHARGE (12V/3A)	1	
7	31740ZJ1003	DIODE ASSY., ENGINE STOP	1	
8	63312ZA7000	GROMMET, TOOL	1	
9	90014ZE6000	BOLT, FLANGE (6X35)	2	
11	901219052000	BOLT, FLANGE (6X25)	2	
12	90658SA0003	CLIP, WIRE HARNESS	1	
13	90673GJ5003	CLIP, CORD	1	
14	901504750003	CLIP, WIRE HARNESS	1	
15	957010600800	BOLT, FLANGE (6X8)	1	

HONDA GX610K1 ENGINE — STARTER MOTOR ASSY.

STARTER MOTOR ASSY.

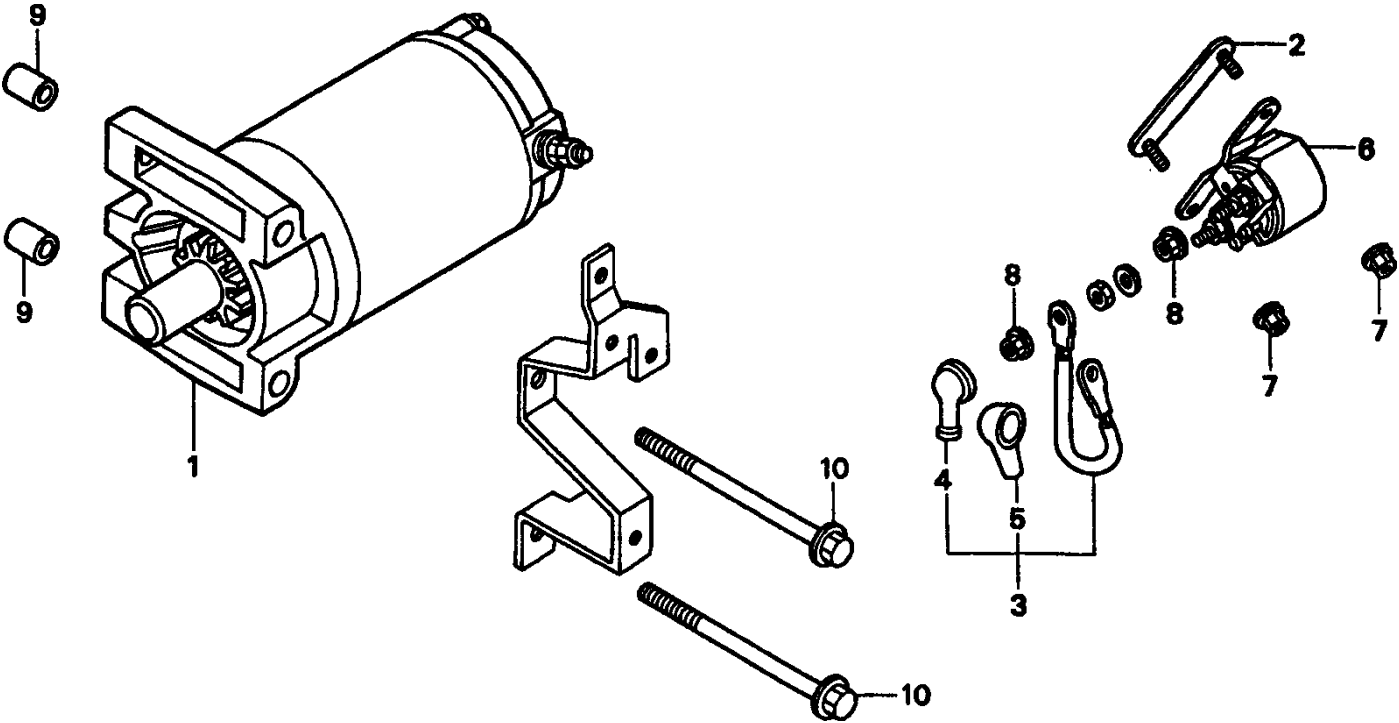

HONDA GX610K1 ENGINE — STARTER MOTOR ASSY.

STARTER MOTOR ASSY.

<u>NO</u>	<u>PART NO</u>	<u>PART NAME</u>	<u>QTY.</u>	<u>REMARKS</u>
1	31200ZJ1004	MOTOR ASSY., STARTER	1	
2	31243ZJ1800	BRACKET, STARTER MAGNETIC SET.	1	
3	32402ZJ1810	CABLE, MAGNET SWITCH	1	INCLUDES ITEMS W/*
4*	32411KB9930	COVER A, MAGNETIC SWITCH	1	
5*	32411402000	COVER, STARTER. MOTOR TERMINAL	1	
6	35850ZJ1811	SWITCH ASSY., STARTER MAGNETIC	1	
7	9405006000	NUT, FLANGE (6MM)	2	
8	9407006080	NUT, WASHER (6MM)	2	
9	9430110120	PIN, DOWEL (10X12)	2	
10	957010811000	BOLT, FLANGE (8X10)	2	

HONDA GX610K1 ENGINE — GOVERNOR/CONTROL ASSY.

GOVERNOR/CONTROL ASSY.

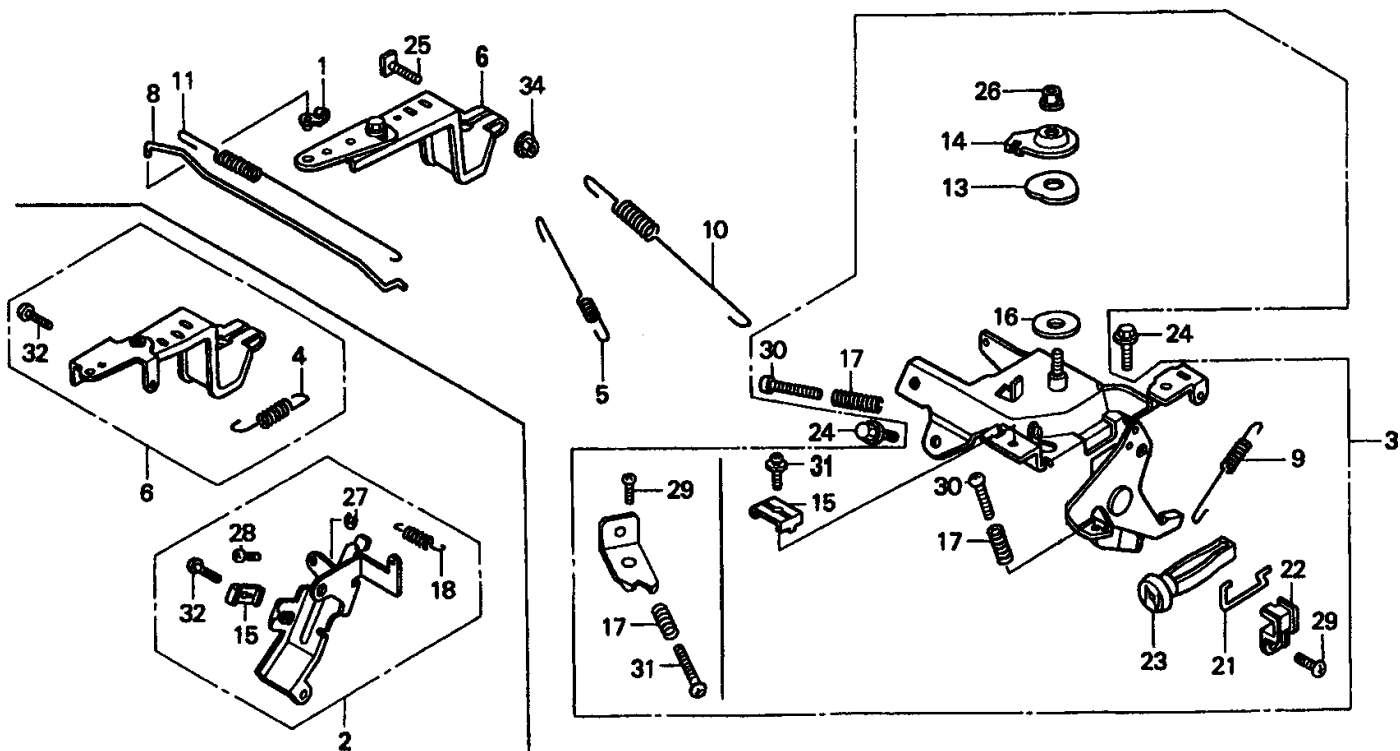

HONDA GX610K1 ENGINE — GOVERNOR/CONTROL ASSY.

GOVERNOR/CONTROL ASSY.

<u>NO</u>	<u>PART NO</u>	<u>PART NAME</u>	<u>QTY.</u>	<u>REMARKS</u>
1	16263ZE3790	JOINT, ROD	1	
2	16265ZJ1U80	STAY ASSY., AUTO THROTTLE	1	INCLUDES ITEMS W/*
3	16500ZJ1U80	CONTROL ASSY.	1	INCLUDES ITEMS W/#
4+	16534ZJ1U80	SPRING, RETURN	1	
5	16534Z16680	SPRING, STARTER	1	
6	16550ZJ1U80	ARM COMP., GOVERNOR.....	1	INCLUDES ITEMS W/+
8	16555ZJ1000	ROD, GOVERNOR	1	
9#	16561ZG1000	SPRING, GOVERNOR	1	
10	16561ZJ1000	SPRING, GOVERNOR	1	
11	16562ZJ1000	SPRING, THROTTLE RETURN	1	
13#	16574ZE1000	SPRING, LEVER	1	
14#	16575ZH8000	WASHER, CONTROL LEVER	1	
15*#	16576891000	HOLDER, CABLE	1	
16#	16578ZE1000	SPACER, CONTROL LEVER	1	
17#	16584883300	SPRING, CONTROL ADJ.	2	
18*	16592ZJ1000	SPRING, CABLE RETURN	1	
21#	16628ZJ1000	ROD, CHOKE KNOB	1	
22#	16649ZJ1000	HOLDER, CHOKE KNOB	1	
23#	17951ZG1000	KNOB, CHOKE	1	
24	90013883000	BOLT, FLANGE (6X12)	2	
25	90015ZE3790	BOLT, GOVERNOR ARM	1	
26#	90114SA0000	NUT, SELFLOCK (6MM)	1	
27*	90605230000	CIRCLIP (5MM)	2	
28*	9350004006OH	SCREW, PAN (4X6)	2	
29#	9350005012OH	SCREW, PAN (5X12)	1	
30#	9350005025OH	SCREW, PAN (5X25)	2	
31#	93500050160A	SCREW, PAN (5X16)	2	
32*+	93500050300H	SCREW, PAN (5X30)	2	
34	9405006000	NUT, FLANGE (6MM)	1	

HONDA GX610K1 ENGINE — LABELS

LABELS

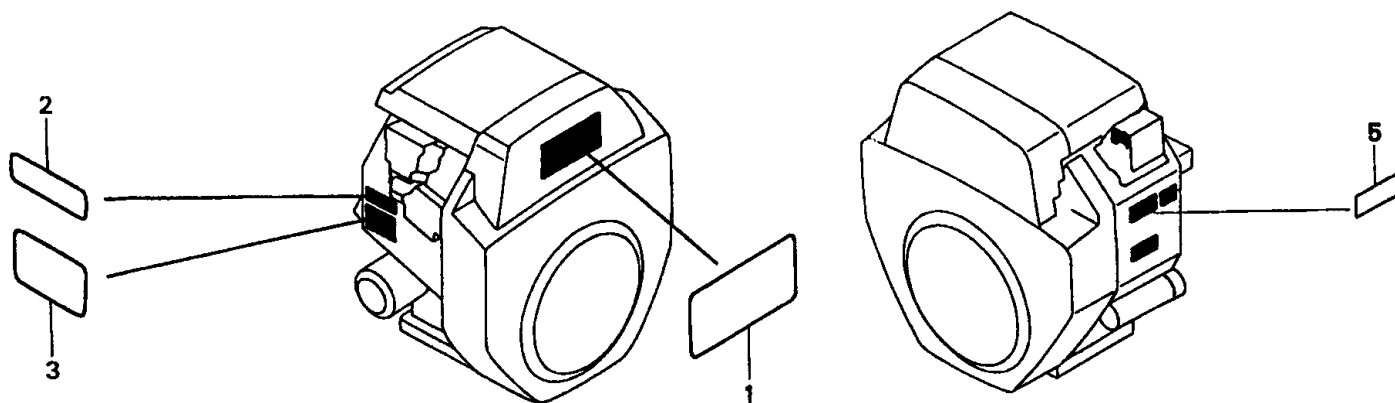

HONDA GX610K1 ENGINE — LABELS

LABELS

<u>NO</u>	<u>PART NO</u>	<u>PART NAME</u>	<u>QTY.</u>	<u>REMARKS</u>
1	87101ZJ0000	MARK, EMBLEM (GX610)	1	
2	87152ZJ0000	LABEL, SPECIFICATION (GX610)	1	
3	87522ZJ1000	LABEL, CAUTION	1	
5	87532ZH8810	MARK, OIL ALERT (E)	1	

HONDA GX610K1 ENGINE —GASKET KIT

GASKET KIT

<u>NO</u>	<u>PART NO</u>	<u>PART NAME</u>	<u>QTY.</u>	<u>REMARKS</u>
	061A1ZJ1000	GASKET KIT	1	INCLUDES ITEMS W/*
1	11381ZJ1000	GASKET, CASE COVER	1	
2*	12251ZJ1003	GASKET, CYLINDER HEAD	2	
3*	12358ZJ1000	GASKET, BREATHER COVER	1	
4*	12391ZJ1000	GASKET, HEAD COVER	2	
5*	16221ZG8000	GASKET, CARBURETOR	2	
6*	17151ZJ1003	GASKET, IN. MANIFOLD	2	
7*	17228ZG8003	GASKET, AIR CLEANER	1	
8*	18333ZJ1000	GASKET, EX. PIPE	2	
9*	91301805000	ORING (26X2.7)	1	

PAYMENT TERMS

Terms of payment for parts are net 10 days.

FREIGHT POLICY

All parts orders will be shipped collect or prepaid with the charges added to the invoice. All shipments are F.O.B. point of origin. Multiquip's responsibility ceases when a signed manifest has been obtained from the carrier, and any claim for shortage or damage must be settled between the consignee and the carrier.

MINIMUM ORDER

The minimum charge for orders from Multiquip is \$15.00 net. Customers will be asked for instructions regarding handling of orders not meeting this requirement.

RETURNED GOODS POLICY

Return shipments will be accepted and credit will be allowed, subject to the following provisions:

1. A Returned Material Authorization must be approved by Multiquip prior to shipment.
2. To obtain a Return Material Authorization, a list must be provided to Multiquip Parts Sales that defines item numbers, quantities, and descriptions of the items to be returned.
 - a. The parts numbers and descriptions must match the current parts price list.
 - b. The list must be typed or computer generated.
 - c. The list must state the reason(s) for the return.
 - d. The list must reference the sales order(s) or invoice(s) under which the items were originally purchased.
 - e. The list must include the name and phone number of the person requesting the RMA.
3. A copy of the Return Material Authorization must accompany the return shipment.

4. Freight is at the sender's expense. All parts must be returned freight prepaid to Multiquip's designated receiving point.
5. Parts must be in new and resalable condition, in the original Multiquip package (if any), and with Multiquip part numbers clearly marked.
6. The following items are not returnable:
 - a. Obsolete parts. (If an item is listed in the parts price book as being replaced by another item, it is obsolete.)
 - b. Any parts with a limited shelf life (such as gaskets, seals, "O" rings, and other rubber parts) that were purchased more than six months prior to the return date.
 - c. Any line item with an extended dealer net price of less than \$5.00.
 - d. Special order items.
 - e. Electrical components.
 - f. Paint, chemicals, and lubricants.
 - g. Decals and paper products.
 - h. Items purchased in kits.
7. The sender will be notified of any material received that is not acceptable.
8. Such material will be held for 5 working days from notification, pending instructions. If a reply is not received within 5 days, the material will be returned to the sender at his expense.
9. Credit on returned parts will be issued at dealer net price at time of the original purchase, less a 15% restocking charge.
10. In cases where an item is accepted for which the original purchase document can not be determined, the price will be based on the list price that was effective twelve months prior to the RMA date.
11. Credit issued will be applied to future purchases only.

PRICING AND REBATES

Prices are subject to change without prior notice. Price changes are effective on a specific date and all orders received on or after that date will be billed at the revised price. Rebates for price declines and added charges for price increases will not be made for stock on hand at the time of any price change.

Multiquip reserves the right to quote and sell direct to Government agencies, and to Original Equipment Manufacturer accounts who use our products as integral parts of their own products.

SPECIAL EXPEDITING SERVICE

A \$20.00 to \$50.00 surcharge will be added to the invoice for special handling including bus shipments, insured parcel post or in cases where Multiquip must personally deliver the parts to the carrier.

LIMITATIONS OF SELLER'S LIABILITY

Multiquip shall not be liable here under for damages in excess of the purchase price of the item with respect to which damages are claimed, and in no event shall Multiquip be liable for loss of profit or good will or for any other special, consequential or incidental damages.

LIMITATION OF WARRANTIES

No warranties, express or implied, are made in connection with the sale of parts or trade accessories nor as to any engine not manufactured by Multiquip. Such warranties made in connection with the sale of new, complete units are made exclusively by a statement of warranty packaged with such units, and Multiquip neither assumes nor authorizes any person to assume for it any other obligation or liability whatever in connection with the sale of its products. A part from such written statement of warranty, there are no warranties, express, implied or statutory, which extend beyond the description of the products on the face hereof.

PARTS AND OPERATION MANUAL

HERE'S HOW TO GET HELP

*PLEASE HAVE THE MODEL AND SERIAL NUMBER
ON-HAND WHEN CALLING*

PARTS DEPARTMENT

800/427-1244 or 310/537-3700

FAX: 800/672-7877 or 310/637-3284

SERVICE DEPARTMENT

800/478-1244 or 310/537-3700

FAX: 310 - 537-4259

WARRANTY DEPARTMENT

800/421-1244, EXT. 279 or 310/537-3700

FAX: 310 - 537-1173

MAIN

800/421-1244 or 310/537-3700

FAX: 310 - 537-3927

Manufactured for MULTQUIP INC.
by
DENYO MANUFACTURING CO., USA



MULTQUIP INC.
POST OFFICE BOX 6254
CARSON, CA 90749
310-537-3700 • 800-421-1244
FAX: 310-537-3927
E-MAIL: mq@multiquip.com
WWW: multiquip.com

Atlanta • Boise • Dallas • Houston • Newark
Quebec, Canada • Manchester, UK • Rio De Janeiro, BR • Guadalajara, MX

Free Manuals Download Website

<http://myh66.com>

<http://usermanuals.us>

<http://www.somanuals.com>

<http://www.4manuals.cc>

<http://www.manual-lib.com>

<http://www.404manual.com>

<http://www.luxmanual.com>

<http://aubethermostatmanual.com>

Golf course search by state

<http://golfingnear.com>

Email search by domain

<http://emailbydomain.com>

Auto manuals search

<http://auto.somanuals.com>

TV manuals search

<http://tv.somanuals.com>