

OPERATION AND PARTS MANUAL



MODEL GAC2.2H PORTABLE GENERATOR (HONDA GX160 GASOLINE ENGINE)

Revision #1 (03/31/10)

To find the latest revision of this
publication, visit our website at:
www.multiquip.com



THIS MANUAL MUST ACCOMPANY THE EQUIPMENT AT ALL TIMES.

TABLE OF CONTENTS

GAC2.2H Portable 60 Hz Generator

Table Of Contents	2
Parts Ordering Procedures.....	3
Safety Information	4-8
Specifications (Generator).....	10
Specifications (Engine).....	11
Dimensions.....	12
Installation	14-15
General Information.....	16
Components (Generator).....	17-18
Inspection/Setup.....	19-20
Operation.....	21-22
Preparation For Long Term Storage	23
Maintenance	24-25
Generator Wiring Diagram	26
Troubleshooting (Engine).....	27-28
Troubleshooting (Generator).....	29
Explanation of Code in Remarks Column	30
Suggested Spare Parts	31

Component Drawings

Nameplate and Decals Assembly.....	32-33
Generator Assembly	34-35
Control Box Assembly	36-37
Pipe Frame Assembly.....	38-39

Honda GX160K1EMA2/ GX160U1EMAN Engines

Cylinder Head Assembly	40-41
Cylinder Barrel Assembly	42-43
Crankcase Cover Assembly.....	44-45
Crankshaft Assembly.....	46-47
Piston Assembly	48-49
Camshaft Assembly.....	50-51
Recoil Starter Assembly	52-53
Fan Cover Assembly.....	54-55
Carburetor Assembly	56-57
Air Cleaner Assembly	58-59
Muffler Assembly	60-61
Flywheel Assembly	62-63
Ignition Coil Assembly	64-65
Governor Control Assembly.....	66-67
Engine Decals Assembly	68-69
Tool Kit	70-71
Terms and Conditions of Sale — Parts.....	72

NOTICE

Specifications and part numbers are subject to change without notice.

PARTS ORDERING PROCEDURES

Ordering parts has never been easier! Choose from three easy options:

Effective:
January 1st, 2006

www.multiquip.com



Order via Internet (Dealers Only):

Order parts on-line using Multiquip's SmartEquip website!

- View Parts Diagrams
- Order Parts
- Print Specification Information



If you have an MQ Account, to obtain a Username and Password, E-mail us at: parts@multiquip.com.

To obtain an MQ Account, contact your District Sales Manager for more information.

Goto www.multiquip.com and click on **Order Parts** to log in and save!

Use the **internet** and qualify for a **5% Discount** on *Standard orders* for all orders which include complete part numbers.*

Note: Discounts Are Subject To Change

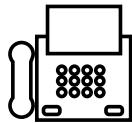

Order via Fax (Dealers Only):

All customers are welcome to order parts via Fax.

Domestic (US) Customers dial:
1-800-6-PARTS-7 (800-672-7877)

Fax your order in and qualify for a **2% Discount** on *Standard orders* for all orders which include complete part numbers.*

Note: Discounts Are Subject To Change



Order via Phone: Domestic (US) Dealers Call:
1-800-427-1244

Non-Dealer Customers:

Contact your local Multiquip Dealer for parts or call 800-427-1244 for help in locating a dealer near you.



International Customers should contact their local Multiquip Representatives for Parts Ordering information.

When ordering parts, please supply:

- | | |
|---|--|
| <input type="checkbox"/> Dealer Account Number | <input type="checkbox"/> Specify Preferred Method of Shipment: |
| <input type="checkbox"/> Dealer Name and Address | <input checked="" type="checkbox"/> UPS/Fed Ex <input checked="" type="checkbox"/> DHL |
| <input type="checkbox"/> Shipping Address (if different than billing address) | <input type="checkbox"/> Priority One <input checked="" type="checkbox"/> Truck |
| <input type="checkbox"/> Return Fax Number | <input type="checkbox"/> Ground |
| <input type="checkbox"/> Applicable Model Number | <input type="checkbox"/> Next Day |
| <input type="checkbox"/> Quantity, Part Number and Description of Each Part | <input type="checkbox"/> Second/Third Day |

NOTICE

All orders are treated as *Standard Orders* and will ship the same day if received prior to 3PM PST.

WE ACCEPT ALL MAJOR CREDIT CARDS!



SAFETY INFORMATION

Do not operate or service the equipment before reading the entire manual. Safety precautions should be followed at all times when operating this equipment. Failure to read and understand the safety messages and operating instructions could result in injury to yourself and others.

SAFETY MESSAGES

The four safety messages shown below will inform you about potential hazards that could injure you or others. The safety messages specifically address the level of exposure to the operator and are preceded by one of four words: **DANGER**, **WARNING**, **CAUTION** or **NOTICE**.

SAFETY SYMBOLS

 **DANGER**

Indicates a hazardous situation which, if not avoided, **WILL** result in **DEATH** or **SERIOUS INJURY**.

 **WARNING**

Indicates a hazardous situation which, if not avoided, **COULD** result in **DEATH** or **SERIOUS INJURY**.





 **CAUTION**

Indicates a hazardous situation which, if not avoided, **COULD** result in **MINOR** or **MODERATE INJURY**.

NOTICE

Addresses practices not related to personal injury.

Potential hazards associated with the operation of this equipment will be referenced with hazard symbols which may appear throughout this manual in conjunction with safety messages.

Symbol	Safety Hazard
	Lethal exhaust gas hazards
	Explosive fuel hazards
	Burn hazards
	Overspeed hazards
	Electric shock hazards

SAFETY INFORMATION

GENERAL SAFETY

CAUTION

- **NEVER** operate this equipment without proper protective clothing, shatterproof glasses, respiratory protection, hearing protection, steel-toed boots and other protective devices required by the job or city and state regulations.



- **NEVER** operate this equipment when not feeling well due to fatigue, illness or when under medication.
- **NEVER** operate this equipment under the influence of drugs or alcohol.



- **ALWAYS** check the equipment for loosened threads or bolts before starting.
- **DO NOT** use the equipment for any purpose other than its intended purposes or applications.

NOTICE

- This equipment should only be operated by trained and qualified personnel 18 years of age and older.
- Whenever necessary, replace nameplate, operation and safety decals when they become difficult read.
- Manufacturer does not assume responsibility for any accident due to equipment modifications. Unauthorized equipment modification will void all warranties.

- **NEVER** use accessories or attachments that are not recommended by Multiquip for this equipment. Damage to the equipment and/or injury to user may result.

- **ALWAYS** know the location of the nearest **fire extinguisher**.



- **ALWAYS** know the location of the nearest **first aid kit**.



- **ALWAYS** know the location of the nearest phone or **keep a phone on the job site**. Also, know the phone numbers of the nearest **ambulance, doctor and fire department**. This information will be invaluable in the case of an emergency.

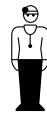

GENERATOR SAFETY

DANGER

- **NEVER** operate the equipment in an explosive atmosphere or near combustible materials. An explosion or fire could result causing severe **bodily harm or even death**.



WARNING

- **NEVER** disconnect any **emergency or safety devices**. These devices are intended for operator safety. Disconnection of these devices can cause severe injury, bodily harm or even death. Disconnection of any of these devices will void all warranties.

CAUTION

- **NEVER** lubricate components or attempt service on a running machine.

NOTICE

- **ALWAYS** ensure generator is on level ground before use.
- **ALWAYS** keep the machine in proper running condition.
- Fix damage to machine and replace any broken parts immediately.
- **ALWAYS** store equipment properly when it is not being used. Equipment should be stored in a clean, dry location out of the reach of children and unauthorized personnel

SAFETY INFORMATION

ENGINE SAFETY

DANGER

- The engine fuel exhaust gases contain poisonous carbon monoxide. This gas is colorless and odorless, and can cause death if inhaled.
- The engine of this equipment requires an adequate free flow of cooling air. **NEVER** operate this equipment in any enclosed or narrow area where free flow of the air is restricted. If the air flow is restricted it will cause injury to people and property and serious damage to the equipment or engine.

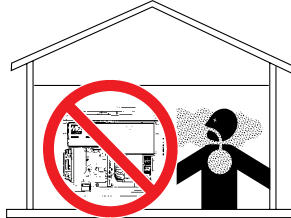

WARNING

- **NEVER** operate the engine with heat shields or guards removed.
- **DO NOT** remove the engine oil drain plug while the engine is hot. Hot oil will gush out of the engine crankcase and severely scald any persons in the general area of the generator.

CAUTION

- **NEVER** touch the hot exhaust manifold, muffler or cylinder. Allow these parts to cool before servicing equipment.



NOTICE

- **NEVER** run engine without an air filter or with a dirty air filter. Severe engine damage may occur. Service air filter frequently to prevent engine malfunction.
- **NEVER** tamper with the factory settings of the engine or engine governor. Damage to the engine or equipment can result if operating in speed ranges above the maximum allowable.
- State Health Safety Codes and Public Resources Codes specify that in certain locations, spark arresters must be used on internal combustion engines that use hydrocarbon fuels. A spark arrester is a device designed



to prevent accidental discharge of sparks or flames from the engine exhaust. Spark arresters are qualified and rated by the United States Forest Service for this purpose. In order to comply with local laws regarding spark arresters, consult the engine distributor or the local Health and Safety Administrator.

FUEL SAFETY

DANGER

- **DO NOT** add fuel to equipment if it is placed inside truck bed with plastic liner. Possibility exists of explosion or fire due to static electricity.

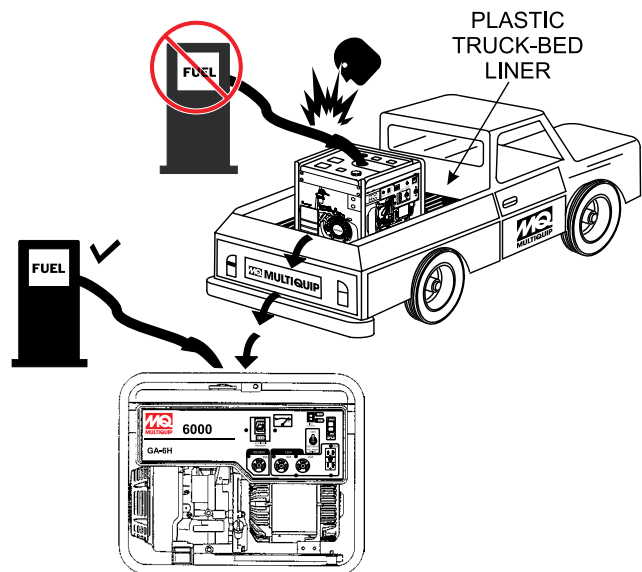

- **DO NOT** start the engine near spilled fuel or combustible fluids. Diesel fuel is extremely flammable and its vapors can cause an explosion if ignited.
- **ALWAYS** refuel in a well-ventilated area, away from sparks and open flames.
- **ALWAYS** use extreme caution when working with **flammable** liquids.
- **DO NOT** fill the fuel tank while the engine is running or hot.
- **DO NOT** overfill tank, since spilled fuel could ignite if it comes into contact with hot engine parts or sparks from the ignition system.
- Store fuel in appropriate containers, in well-ventilated areas and away from sparks and flames.

SAFETY INFORMATION

- **NEVER** use fuel as a cleaning agent.
- **DO NOT** smoke around or near the equipment. Fire or explosion could result from fuel vapors or if fuel is spilled on a hot engine.



ELECTRICAL SAFETY

DANGER

- Turn generator and all circuit breakers **OFF** before performing maintenance on the generator or making contact with output receptacles.

- **NEVER** insert any objects into the output receptacles during operation. This is extremely dangerous. The possibility exists of **electrical shock, electrocution or death.**



- Backfeed to a utility system can cause **electrocution** and/or property damage. **NEVER** connect the generator to a building's electrical system without a transfer switch or other approved device. All installations should be performed by a **licensed electrician** in accordance with all applicable laws and electrical codes. Failure to do so could result in electrical shock or burn, causing **serious injury or even death.**



Power Cord/Cable Safety

DANGER

- **NEVER** let power cords or cables **lay in water.**
- **NEVER** stand in water while AC power from the generator is being transferred to a load.
- **NEVER** use **damaged** or **worn** cables or cords when connecting equipment to generator. Inspect for cuts in the insulation.

- **NEVER** grab or touch a live power cord or cable with wet hands. The possibility exists of **electrical shock, electrocution or death.**



- Make sure power cables are securely connected to the generator's output receptacles. Incorrect connections may cause electrical shock and damage to the generator.

NOTICE

- **ALWAYS** make certain that proper power or extension cord has been selected for the job. See Cable Selection Chart in this manual.

Grounding Safety

DANGER

- **ALWAYS** make sure that electrical circuits are properly grounded to a suitable earth ground (ground rod) per the National Electrical Code (NEC) and local codes before operating generator. **Severe injury or death by electrocution** can result from operating an ungrounded generator.

- **NEVER** use gas piping as an electrical ground.

BATTERY SAFETY (ELECTRIC START ONLY)

DANGER

- **DO NOT** drop the battery. There is a possibility that the battery will explode.

- **DO NOT** expose the battery to open flames, sparks, cigarettes, etc. The battery contains combustible gases and liquids. If these gases and liquids come into contact with a flame or spark, an explosion could occur.



- **DO NOT** charge battery if frozen. Battery can explode. When frozen, warm the battery to at least 61°F (16°C).

WARNING

- **ALWAYS** wear safety glasses when handling the battery to avoid eye irritation. The battery contains acids that can cause injury to the eyes and skin.



- Use well-insulated gloves when picking up the battery.
- **ALWAYS** keep the battery charged. If the battery is not charged, combustible gas will build up.
- **ALWAYS** recharge the battery in a well-ventilated environment to avoid the risk of a dangerous concentration of combustible gasses.

SAFETY INFORMATION

- If the battery liquid (dilute sulfuric acid) comes into contact with **clothing or skin**, rinse skin or clothing immediately with plenty of water.
- If the battery liquid (dilute sulfuric acid) comes into contact with **eyes**, rinse eyes immediately with plenty of water and contact the nearest doctor or hospital to seek medical attention.

CAUTION

- **ALWAYS** disconnect the **NEGATIVE battery terminal** before performing service on the generator.
- **ALWAYS** keep battery cables in good working condition. Repair or replace all worn cables.

TRANSPORTING SAFETY

CAUTION

- **NEVER** allow any person or animal to stand underneath the equipment while lifting.

NOTICE

- Before lifting, make sure that the equipment parts (lifting bail if equipped) are not damaged and screws are not loose or missing.
- Always make sure crane or lifting device has been properly secured to the lifting bail (hook) of the equipment.
- **ALWAYS** shutdown engine before transporting.
- **NEVER** lift the equipment while the engine is running.
- Tighten fuel tank cap securely and close fuel cock to prevent fuel from spilling.
- Use adequate lifting cable (wire or rope) of sufficient strength.
- Use one point suspension hook and lift straight upwards.
- **DO NOT** lift machine to unnecessary heights.
- **ALWAYS** tie down equipment during transport by securing the equipment with rope.

ENVIRONMENTAL SAFETY

NOTICE

- Dispose of hazardous waste properly. Examples of potentially hazardous waste are used motor oil, fuel and fuel filters.
- **DO NOT** use food or plastic containers to dispose of hazardous waste.
- **DO NOT** pour waste, oil or fuel directly onto the ground, down a drain or into any water source.



SPECIFICATIONS (GENERATOR)

Table 1. Specifications (Generators)		
AC Generator 60 Hz AC Power Sourc	Model	GAC 2.2H
	Type	Brushless Revolving Field Type
	Excitation	Solid State, Statically Excited System
	Speed	3,600 RPM
	Cooling System	Self-Ventilation
	Continuous Power Output	1.8 kW
	Max Power Output	2.2 kW
	Rated Voltage	120V
	Current Max/Continuous (120V)	15 amps
	Phase	Single Phase (2 wire)
	Frequency	60 Hz
Power Factor	1	
Dimensions (L x W x H)		19.68 x 16.14 X 18.30 in. (500 X 410 X 465 mm)
Dry Net Weight		106 lbs. (48 kg.)

NOTICE

In keeping with Multiquip's policy of constantly improving its products, the specifications quoted herein are subject to change without prior notice.

SPECIFICATIONS (ENGINE)

Table 2. Specifications (Engine)		
Engine	Model	HONDA GX160K1EMA2 HONDA GX160U1EMAN
	Type	4 stroke, Single Cylinder, OHV, Gasoline Engine
	Bore X Stroke	2.68 in. X 1.77 in. (68 mm x 45 mm.)
	Displacement	9.95 cu-in (163 cm ³)
	Max Output	5.5 H.P./3600 R.P.M.
	Fuel	Unleaded Automobile Gasoline
	Fuel Capacity	3.16 gallons (12 liters)
	Lube Oil Capacity	.63 quarts (0.6 liters)
	Oil Alert System	Yes
	Speed Control Method	Centrifugal Fly-weight Type
	Starting Method	Recoil Start
Dimensions (L x W x H)		12.0 x 14.4 X 13.2 in. (304 X 362 X 335 mm)
Dry Net Weight		33.1 lbs. (15 kg.)

Effects of Altitude and Heat

The maximum output of the engines listed above are applicable to supplying electrical power for continuous service at ambient conditions in accordance with SAE Test cord J607. The above ambient conditions are at standard sea level, with a barometric reading of 29.92 inches and a temperature of 60° F (15.5° C).

Generally, the engine's output power will decrease 3-1/2% for each 1000 feet (305 meters) of altitude above sea level, and 1% for each 10° F (-12.2° C) above the standard temperature of 60° F (15.5° C).

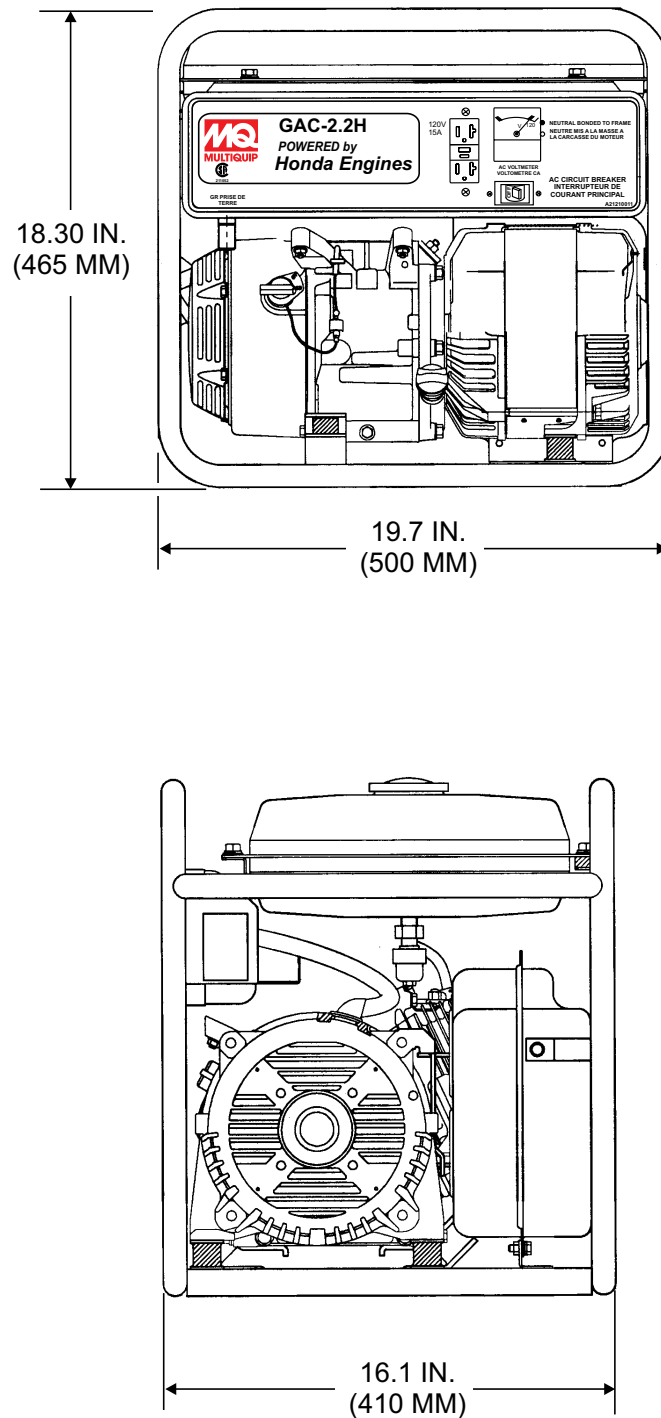

Figure 1. Dimensions

CONNECTING THE GROUND

The nut and ground terminal on the generators should always be used to connect the generators to a suitable ground. The ground cable should be #8 size wire minimum.

At the generator, connect the terminal of the ground cable between the lock washer and the nut (Figure 2) and tighten the nut fully. Connect the other end of the ground cable to a suitable earth ground (ground rod).

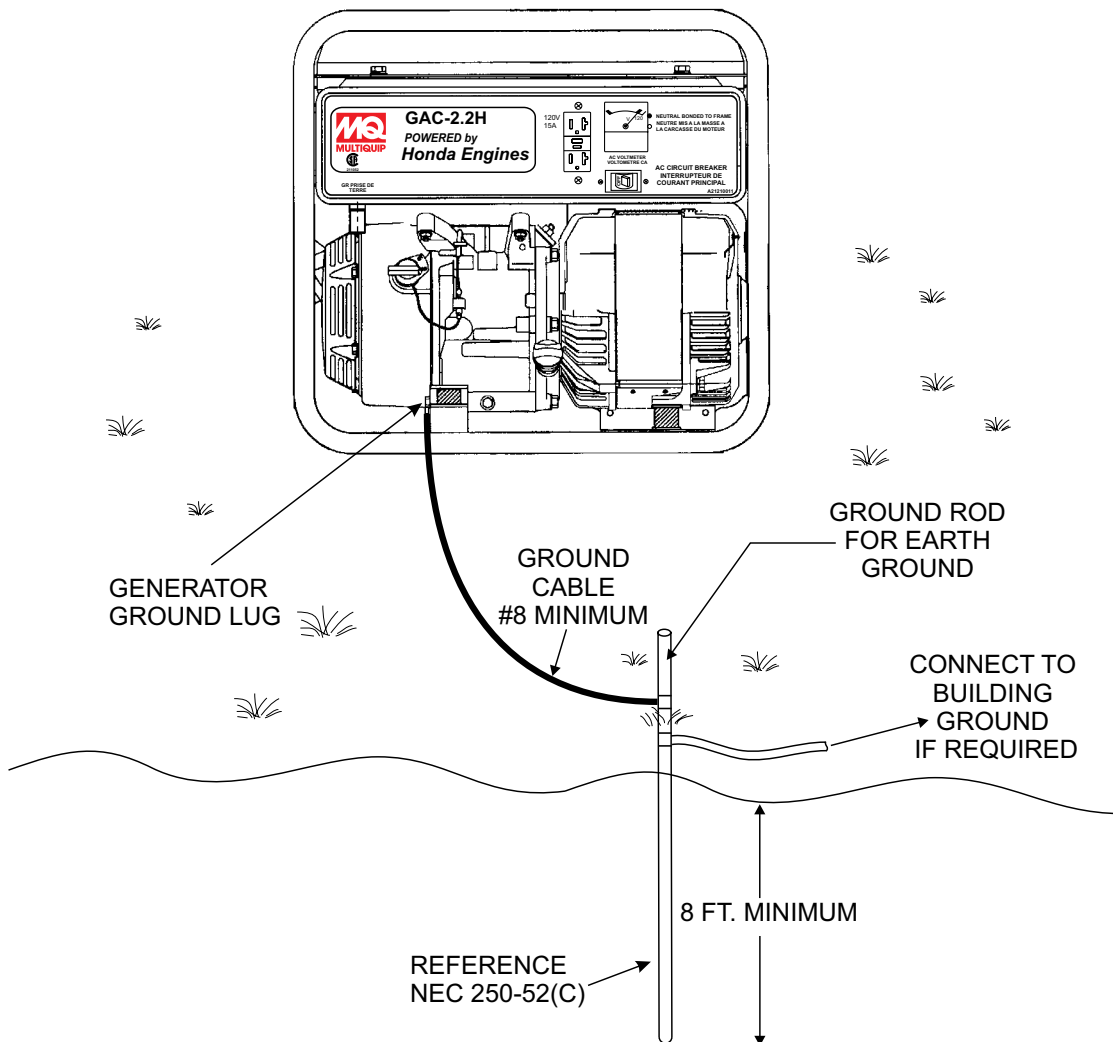

Figure 2. Generator Grounding

OUTDOOR INSTALLATION

If possible install the generator in a area that is free of debris, bystanders, and overhead obstructions. Make sure the generator is on secure level ground so that it cannot slide or shift around.

The installation site must be relatively free from moisture and dust. All electrical equipment should be protected from excessive moisture. Failure to do will result in deterioration of the insulation and will result in short circuits and grounding.

Foreign materials such as dust, sand, lint and abrasive materials have a tendency to cause excessive wear to engine and alternator parts.

INDOOR INSTALLATION

 **WARNING**

 Pay close attention to ventilation when operating the generator inside tunnels and caves. The engine exhaust contains noxious elements. Engine exhaust must be routed to a ventilated area

Exhaust gases from gas engines are extremely poisonous. Whenever an engine is installed indoors the exhaust fumes must be vented to the outside. The engine should be installed at least two feet from any outside wall. Using an exhaust pipe which is too long or too small can cause excessive back pressure which will cause the engine to heat excessively and possibly burn the valves.

PLACEMENT

The generators should always be placed on a flat level surface when it is running. **DO NOT** place the generator on slopes, the possibility exists that the generator could slide.

 **DANGER**

 An electric shock is apt to happen when vibrators are used. Pay close attention to handling when operating vibrators and always use rubber boots and gloves to insulate the body from a short circuit.

GENERATOR GROUNDING

To guard against electrical shock and possible damage to the equipment, it is important to provide a good **EARTH** ground.

Article 250 (Grounding) of the National Electrical Code (NEC) provides guide lines for proper grounding and specifies that the cable ground shall be connected to the grounding system of the building as close to the point of cable entry as practical.

NEC articles 250-64(b) and 250-66 set the following grounding requirements:

1. Use one of the following wire types to connect the generator to earth ground.
 - a. Copper - 10 AWG (5.3 mm²) or larger.
 - b. Aluminum - 8 AWG (8.4 mm²) or larger.
2. When grounding the generator (Figure 2) connect the ground cable between the lock washer and the nut on the generator and tighten the nut fully. Connect the other end of the ground cable to earth ground.
3. NEC article 250-52(c) specifies that the earth ground rod should be buried a minimum of 8 ft. into the ground.

NOTICE

When connecting the generator to any buildings electrical system **ALWAYS** consult with a licensed electrician.

GAC2.2H FAMILIARIZATION

Generator

The Multiquip GAC2.2H generator has been designed as a portable dual purpose power source for 60 Hz (single phase) lighting facilities, power tools, submersible pumps and other industrial and construction machinery.

This generator is mounted on rubber vibration isolators that have a steel base backplate which is attached to the protective steel pipe carrying frame. The protective carrying frame is made of steel tubing and fully wraps around the generators to protect against damage. See Figures 3, and 4 for the basic controls and indicators for the generator.

This portable generator is supplied with a electrical control box. To reduce vibration caused by the engine, the control box is also placed on rubber isolators.

Control Box

The control box is provided with the following:

- 120V GFCI receptacle.
- 15 Amp Main Circuit Breaker.
- AC Voltmeter
- Ground Terminal

DANGER

Before connecting this generator to any building's electrical system, a licensed electrician must install an isolation (transfer) switch.

Serious injury or death may result without this transfer switch.

COMPONENTS (GENERATOR)

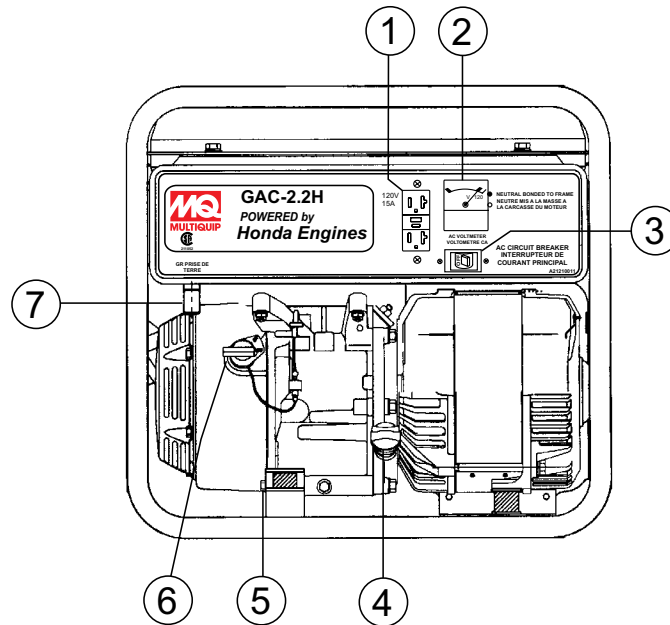

Figure 3. Generator Components

1. **GFCI Duplex Receptacle** – NEMA 5-15R, GFCI receptacle will provide 120V @ 15 amps.
2. **AC-Voltmeter** – Indicates (with a mark) the rated 60 Hz (single-phase) output voltage. In addition the voltmeter can also be used as a diagnostic tool. If the voltmeter indicator (needle) is below the rated voltage, engine problems may exist (low/high RPM's).
3. **Main Breaker** – single-pole, 15 amp circuit breaker protects the generator from short circuiting or overloading. When starting the generator always have circuit breaker placed in the **OFF** position.
4. **Engine Oil Filler Cap** – Remove cap/dipstick when the adding of engine oil is required. See Table 4 for recommended type engine oil.
5. **Chassis Ground** – This ground connection point should be connected to a good earth ground (ground rod).
6. **Engine ON/OFF Switch** – Use this switch to start and stop the engine. Place switch in ON position to start engine, to stop engine place switch in OFF position.
7. **GFCI Ground** – GFCI ground connection point.

To prevent damage to the generator or power tools due to low output voltage, turn the generator **OFF** and consult your authorized Multiquip service dealer.

COMPONENTS (GENERATOR)

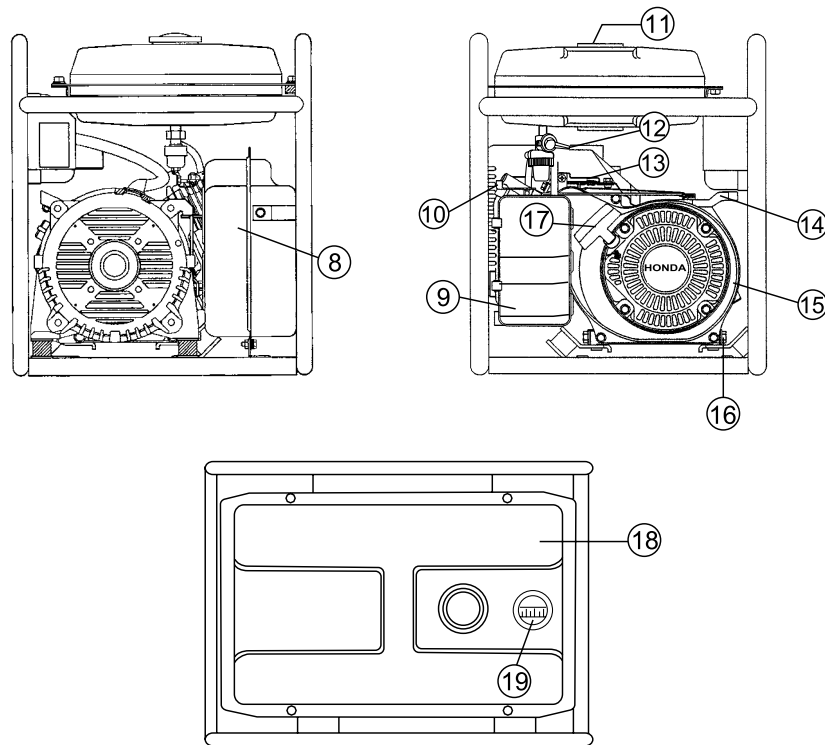

Figure 4. Generator Components (Continued)

8. **Muffler/Heat Shield** – Used to reduce noise and emissions. **NEVER** touch this heat shield when the generator/welder is in use. Always allow time for engine to cool before servicing.
9. **Air Cleaner** – Prevents dirt and other debris from entering the fuel system. Remove wing-nut on top of air filter canister to gain access to filter element. **NEVER** run the engine without an air cleaner.
10. **Spark Plug** – Provides spark to the ignition system. Set spark plug gap to 0.6 - 0.7 mm (0.028 - 0.031 inch) Clean spark plug once a week.
11. **Fuel Tank Cap** – Remove cap to add unleaded gasoline to the fuel tank. Replenish with clean unleaded gasoline. Make sure cap is tightened securely. **DO NOT** over fill.
12. **Fuel Cock Lever** – Turn lever downward to start (down) the flow of fuel into the carburetor. Turn upward to stop (up) the flow of fuel.
13. **Choke Lever** – Used for starting the engine. Close the choke lever when starting a cold engine or in cold weather conditions. The choke enriches the fuel mixture. Open the choke lever if starting a warm engine or in warm weather conditions.
14. **Throttle Lever** – Regulates engine speed.
15. **Engine** – This generator uses a 5.0 HP Honda air-cooled, 4-stroke, single cylinder, overhead camshaft gasoline engine. Engine uses unleaded gasoline.
16. **Engine Oil Drain Plug** – Remove this plug to drain engine oil from the crankcase.
17. **Recoil Starter (pull rope)** – Manual-starting method. Pull the starter grip until resistance is felt, then pull briskly and smoothly.
18. **Fuel Tank** – Fuel tank capacity is 3.16 gallons (12 liters)
19. **Fuel Gauge** – This gauge is located on top of the fuel tank. Read this gauge to determine when fuel is low.

NOTICE

This **HONDA** engine is equipped with a low oil shutdown capability. A built in sensor will automatically turn off the engine should the oil level fall below a safe operating condition. Make sure the generators is placed on level ground. Placing the generators on level ground will ensure that the low oil sensor will function properly.

GENERAL INSPECTION PRIOR TO OPERATION

Ground Power Tools

When using power tools or electrical equipment requiring AC power from the generator, make sure power tool cord has a ground pin or is double insulated as shown in Figure 5.

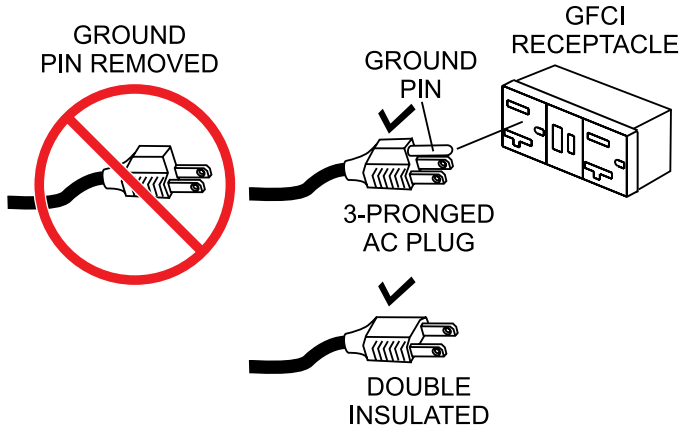

Figure 5. Ground Pin

NOTICE

Double-insulated power tools and small appliances have specially insulated housings that eliminate the need for a ground pin. These types of double-insulated power cords are designed so that no part of the device will be electrically live even if the internal insulation fails.

Extension Cable

When electric power is to be provided to various tools or loads at some distance from the generator, extension cords are normally used. Cables should be sized to allow for distance in length and amperage so that the voltage drop between the generators and point of use (load) is held to a minimum. Use the cable selection chart (Table 3) as a guide for selecting proper cable size.

! DANGER

NEVER use power tools or equipment that do not have a ground capability, the possibility exists of electrocution, electrical shock or burn, which can cause severe bodily harm or even **DEATH!**

Main Circuit Breaker

ALWAYS place the main circuit breaker in the **OFF** position prior to starting the engine.

Table 3. Cable Selection (60 Hz, Single Phase Operation)

Current In Amperes	Load In Watts		Maximum Allowable Cable Length			
	120 Volts	240 Volts	#10 Wire	#12 Wire	#14 Wire	#16 Wire
2.5	300	600	1000 ft.	600 ft.	375 ft.	250 ft.
5	600	1200	500 ft.	300 ft.	200 ft.	125 ft.
7.5	900	1800	350 ft.	200 ft.	125 ft.	100 ft.
10	1200	2400	250 ft.	150 ft.	100 ft.	
15	1800	3600	150 ft.	100 ft.	65 ft.	
20	2400	4800	125 ft.	75 ft.	50 ft.	

CAUTION: Equipment damage can result from low voltage.

Before Starting

1. Read safety instructions at the beginning of manual.
2. Clean the generator, removing dirt and dust, particularly the engine cooling air inlet, carburetor and air cleaner.
3. Check the air filter for dirt and dust. If air filter is dirty, replace air filter with a new one as required.
4. Check carburetor for external dirt and dust. Clean with dry compressed air.
5. Check fastening nuts and bolts for tightness

Engine Oil Check

1. To check the engine oil level, place the generator on secure level ground with the engine stopped.
2. Remove the filler dipstick from the engine oil filler hole (Figure 6) and wipe clean.

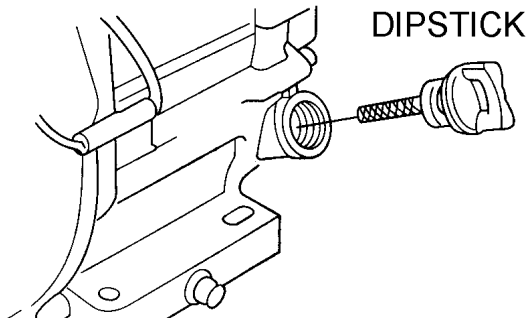

Figure 6. Engine Oil Dipstick Removal

3. Insert and remove the dipstick without screwing it into the filler neck. Check the oil level shown on the dipstick.
4. If the oil level is low (Figure 7), fill to the edge of the oil filler hole with the recommended oil type (Table 4). Maximum oil capacity is .63 quarts (0.6 liters).

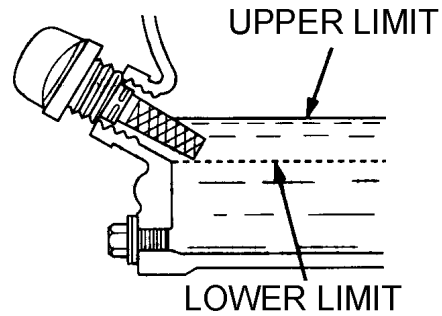

Figure 7. Engine Oil Dipstick(Oil Level)

Table 4. Oil Type

Season	Temperature	Oil Type
Summer	25°C or Higher	SAE 10W-30
Spring/Fall	25°C~10°C	SAE 10W-30/20
Winter	0°C or Lower	SAE 10W-10

Fuel Check

1. Close the fuel cock before filling the fuel tank.
2. Remove the fuel cap located on top of fuel tank.
3. Read the fuel gauge located on top of the fuel tank (Figure 8) to determine if the fuel level is low. If fuel is low, replenish with clean unleaded fuel.

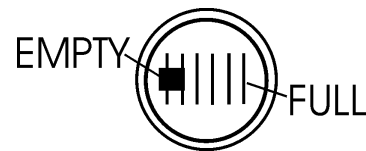

Figure 8. Fuel Gauge

4. When refueling, be sure to use a strainer for filtration. **DO NOT** top-off fuel. **DO NOT** fill the tank beyond capacity. Wipe up any spilled fuel **immediately!**

This section is intended to assist the operator with the initial start-up of the portable generator. It is extremely important that this section be read carefully before attempting to use the generators in the field.

Before Starting the Engine

1. Be sure to disconnect all electrical loads from the generator prior to starting the engine.
2. **NEVER** start the engine with the main circuit breaker in the **ON** position. Always place this circuit breaker (Figure 9) in the **OFF** position before starting.

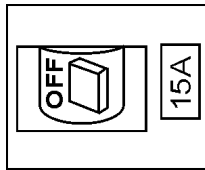

Figure 9. Main Circuit Breaker (OFF)

Starting the Engine

1. Place the engine fuel valve lever (Figure 10) to the **ON** position.

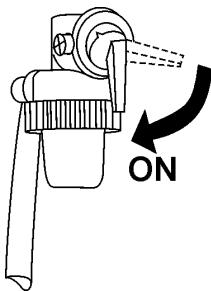

Figure 10. Engine Fuel Valve Lever (ON)

2. Place the choke lever (Figure 11) in the **CLOSED** position if starting a cold engine.

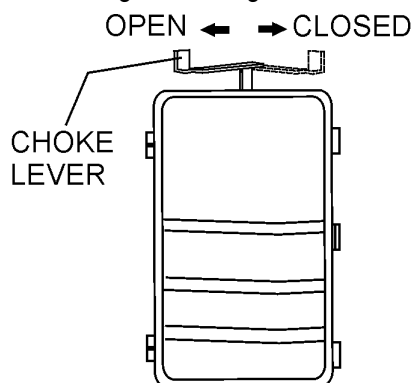

Figure 11. Choke Lever

3. Place the choke lever (Figure 11) in the **OPEN** position if starting a warm engine or the temperature is warm.
4. Place the **engine ON/OFF** switch (Figure 12) in the **ON** position.

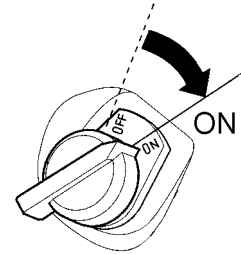

Figure 12. Engine ON/OFF Switch (ON)

5. Grasp the starter grip (Figure 13) and slowly pull it out. The resistance becomes the hardest at a certain position, corresponding to the compression point. Pull the starter grip briskly and smoothly for starting.

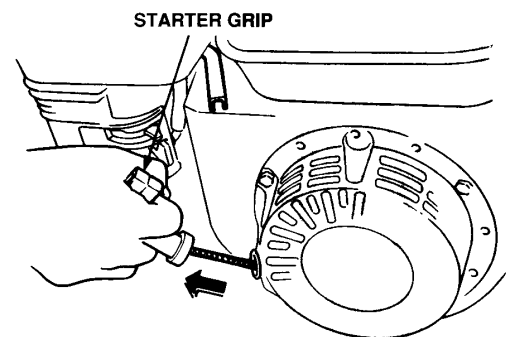

Figure 13. Starter Grip

6. If the engine has started, slowly return the choke lever (Figure 11) to the **OPEN** position. If the engine has not started repeat steps 1 through 5.
7. Before the generator is placed into operation, run the engine for 3-5 minutes. Check for abnormal smells, fuel leaks, and noises that would associate with loose components.

NOTICE

DO NOT pull the starter rope all the way to the end.

DO NOT release the starter rope after pulling. Allow it to rewind as soon as possible.

- Place main circuit breaker (Figure 14) in the **ON** position.

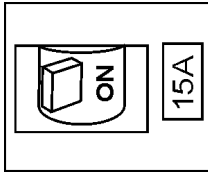

Figure 14. Main Circuit Breaker (ON)

- Read the voltmeter on the front panel of the generator (Figure 15) and verify that 120 VAC is present at the GFCI duplex receptacle. For additional verification of voltage, an external voltmeter can be used to measure the output voltage as shown in Figure 15.

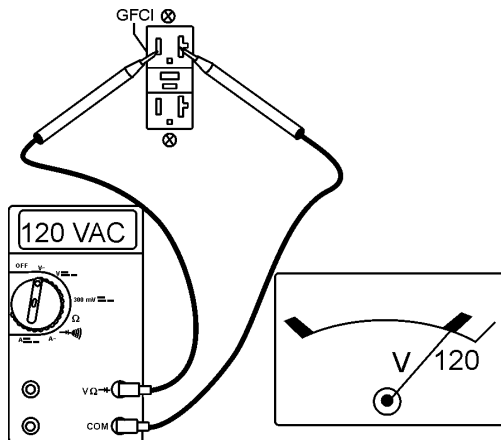

Figure 15. 120V/GFCI Receptacle

- Connecting of loads (power tools, lighting ect.) to the generator receptacles can now be done.

Stopping the Engine (Normal Shutdown)

- Place the main circuit breaker (Figure 16) in the **OFF** position.

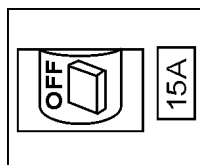

Figure 16. Main Circuit Breaker (OFF)

- Let the engine run at idle with no load for 2-3 minutes.
- Place the **engine ON/OFF** switch (Figure 17) in the **OFF** position.

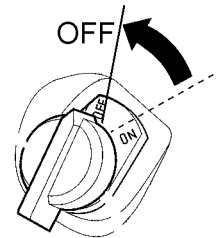

Figure 17. Engine ON/OFF Switch (OFF)

- Place the engine fuel valve lever (Figure 18) in the **OFF** position.

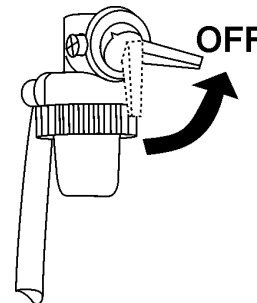

Figure 18. Engine Fuel Valve Lever (OFF)

- Remove all loads from the generator.

Emergency Shutdown

- Place the **engine ON/OFF** switch (Figure 17) in the **OFF** position.

PREPARATION FOR LONG TERM STORAGE

Generators Storage

For storage of the generating set for over 30 days, the following is required:

- Drain the fuel tank completely, or add STA-BIL to the fuel.
- Run the engine until the gasoline in the carburetor is completely consumed.
- Completely drain the oil from the crankcase and refill with fresh oil.
- Remove the spark plug, pour 2 or 3 cc of SAE 30 oil into the cylinder and crank slowly to distribute the oil.
- Slowly rotate the engine a few times with the starter rope and install a new plug.
- Pull out the starter rope slowly and stop at the compression point.
- Clean all external parts of the generating set with a cloth.
- Cover the generating set and store in a clean, dry place.

MAINTENANCE

Use Table 5 as a general maintenance guideline when servicing your engine. For more detail engine maintenance information, refer to the engine owner's manual supplied with your engine.

Table 5. Engine Maintenance Schedule							
DESCRIPTION (3)	OPERATION	BEFORE	FIRST MONTH OR 10 HRS.	EVERY 3 MONTHS OR 25 HRS.	EVERY 6 MONTHS OR 50 HRS.	EVERY YEAR OR 100 HRS.	EVERY 2 YEARS OR 200 HRS.
Engine Oil	CHECK	X					
	CHANGE						
Air Cleaner	CHECK	X	X				
	CHANGE			X (1)			
All Nuts & Bolts	RETIGHTEN IF NECESSARY	X					
Spark Plug	CHANGE				X		
	REPLACE						X
Cooling Fins	CHECK				X		
Spark Arrester	CLEAN					X	
Fuel Tank	CLEAN					X	
Fuel Filter	CHECK					X	
Idle Speed	CHECK-ADJUST					X (2)	
Valve Clearance	CHECK-ADJUST						X (2)
Fuel lines	CHECK	Every 2 years, replace if necessary (2)					

(1) Service more frequently when used in **DUSTY** areas.

(2) These items should be serviced by your service dealer, unless you have the proper tools and are mechanically proficient. Refer to the HONDA Shop Manual for service procedures.

(3) For commercial use, log hours of operation to determine proper maintenance intervals.

Maintenance

Perform the scheduled maintenance procedures as defined by Table 5:

Daily

- Thoroughly remove dirt and oil from the engine and control area. Clean or replace the air cleaner elements as necessary. Check and retighten all fasteners as necessary.

Weekly

- Remove the fuel filter cap and clean the inside of the fuel tank.
- Remove or clean the filter at the bottom of the tank.
- Remove and clean the spark plug (Figure 19), then adjust the spark gap to 0.024 ~0.028 inch (0.6~0.7 mm). This unit has electronic ignition, which requires no adjustments.

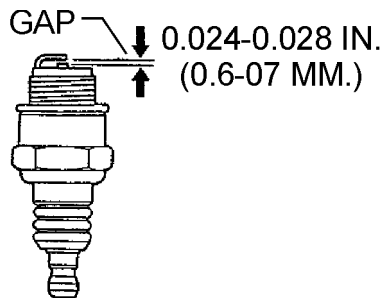

Figure 19. Spark Plug Gap

Engine Oil

- Drain the engine oil when the oil is warm as shown in Figure 20.
- Remove the oil drain bolt and sealing washer and allow the oil to drain into a suitable container.
- Replace engine oil with recommended type oil as listed in Table 4. For engine oil capacity, see Table 2 (engine specifications). **DO NOT** overfill.
- Install drain bolt with sealing washer and tighten securely.

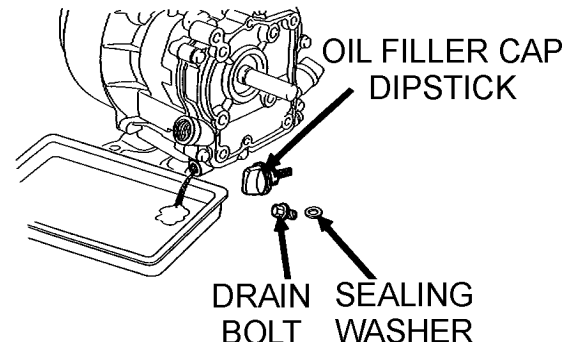

Figure 20. Draining Engine Oil

Engine Air Cleaner

- Remove the air cleaner cover and foam filter element as shown in Figure 21.

⚠ DANGER

DO NOT use gasoline as a cleaning solvent, the possibility exists of fire or explosion which can cause damage to the equipment and severe bodily harm or even **DEATH!**

- Clean foam element in warm, soapy water or nonflammable solvent. Rinse and dry thoroughly. Dip the element in clean engine oil and completely squeeze out the excess oil from the element before installing.

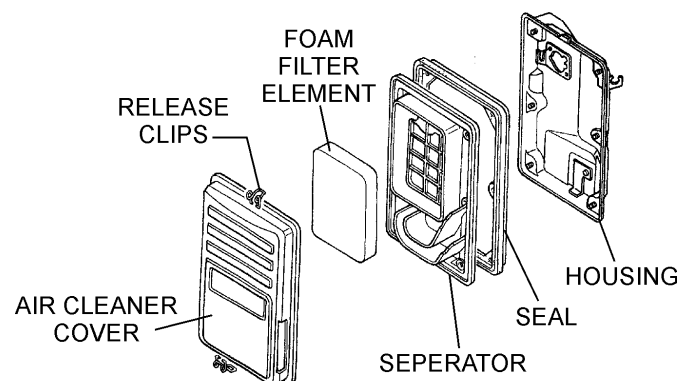
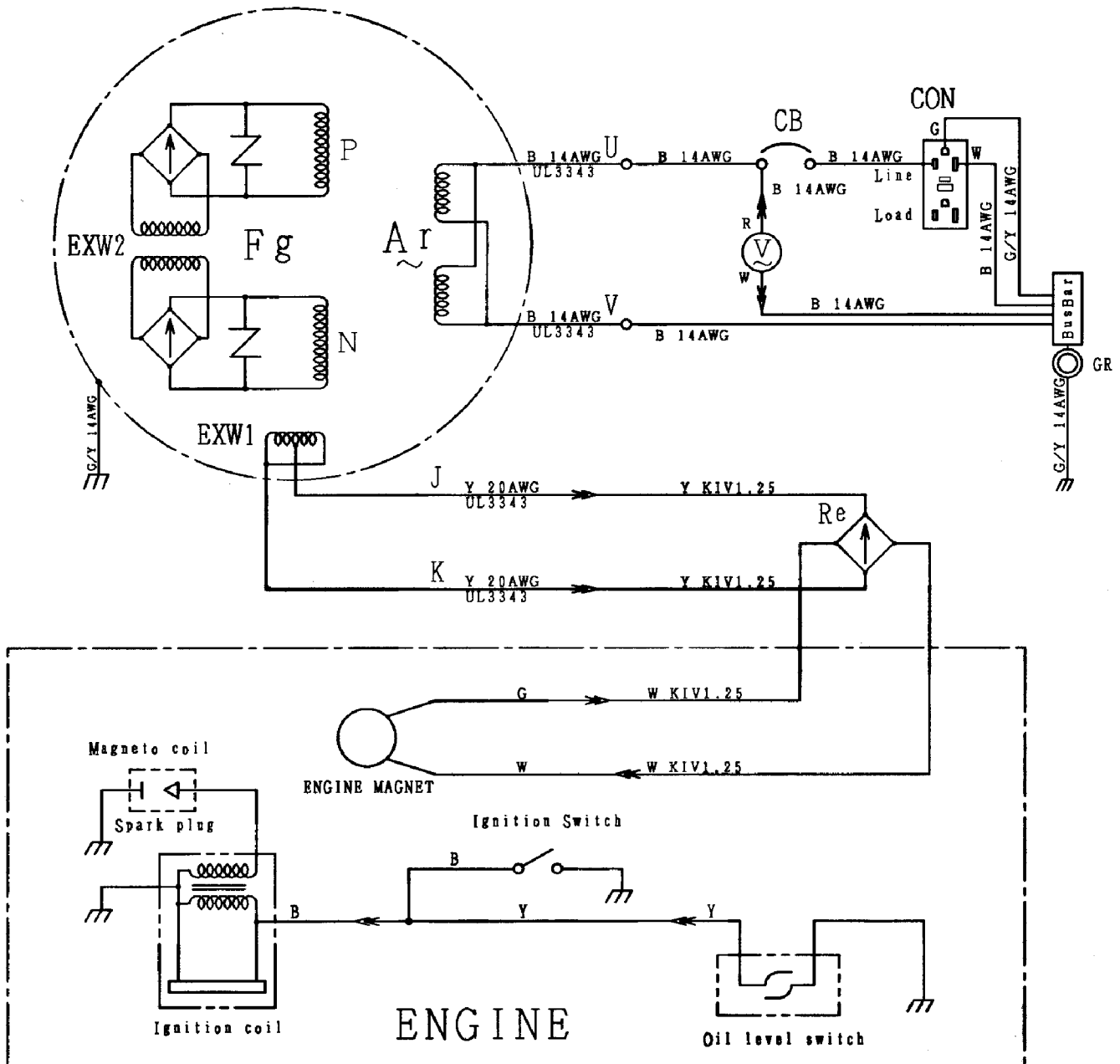

Figure 21. Engine Air Cleaner

GENERATOR WIRING DIAGRAM



SYMBOL	PART NAME
Ar	Armature Winding
Fg-PN	Field Winding
EXW1-2	Excitation Winding
V	AC Voltmeter (120/240)
Re	Rectifier
CON	Receptacle 5-15R
CB	UPM-1 15A
CB1	CP-31E/15N 15A

Wiring Color Code			
Symbol	Color	Symbol	Color
B	BLACK	R	RED
L	BLUE	W	WHITE
BR	BROWN	Y	YELLOW
G	GREEN	LB	LIGHT BLUE
GR	GRAY	LG	LIGHT GREEN
V	VIOLET	O	ORANGE
P	PINK		

Figure 22. Generator Wiring Diagram

Table 6. Engine Troubleshooting

Symptom	Possible Cause	Solution
Difficult to start. Fuel is available but no SPARK at spark plug.	Spark plug bridging?	Check gap, insulation or replace spark plug.
	Carbon deposit on spark plug?	Clean or replace spark plug.
	Short circuit due to deficient spark plug insulation?	Check spark plug insulation. Replace if worn.
	Improper spark plug gap?	Set to proper gap.
Difficult to start. Fuel is available and SPARK is present at the spark plug.	ON/OFF switch is shorted?	Check switch wiring. Replace switch.
	Ignition coil defective?	Replace ignition coil.
	Improper spark gap, points dirty?	Set correct spark gap and clean points.
	Condenser insulation worn or short circuiting?	Replace condenser.
	Spark plug wire broken or short circuiting?	Replace defective spark plug wiring.
Difficult to start. Fuel is available, SPARK is present at the spark plug and compression is normal.	Wrong fuel type?	Flush fuel system and replace with correct type of fuel.
	Water or dust in fuel system?	Flush fuel system.
	Air cleaner dirty?	Clean or replace air cleaner.
Difficult to start. Fuel is available, SPARK is present at the spark plug and compression is low.	Suction/exhaust valve stuck or protruded?	Reseat valves.
	Piston ring and/or cylinder worn?	Replace piston rings or piston.
	Cylinder head and/or spark plug not tightened properly?	Torque cylinder head bolts and spark plug.
	Head gasket and/or spark plug gasket damaged?	Replace head and spark plug gaskets.
No fuel present at carburetor.	Fuel not available in fuel tank?	Fill with correct type of fuel.
	Fuel cock does not open properly?	Apply lubricant to loosen fuel cock lever. Replace if necessary.
	Fuel filter clogged?	Replace fuel filter.
	Fuel tank cap breather hole clogged?	Clean or replace fuel tank cap.
	Air in fuel line?	Bleed fuel line
Weak in power. Compression is proper and does not misfire.	Air cleaner dirty?	Clean or replace air cleaner.
	Improper level in carburetor?	Check float adjustment. Rebuild carburetor.
	Defective spark plug?	Clean or replace spark plug.

Table 6. Engine Troubleshooting (Continued)

Symptom	Possible Cause	Solution
Weak in power. Compression is proper but misfires.	Water in fuel system?	Flush fuel system and replace with correct type of fuel.
	Dirty spark plug?	Clean or replace spark plug
	Ignition coil defective?	Replace ignition coil.
Engine overheats.	Spark plug heat value improper?	Replace with correct type of spark plug.
	Incorrect type of fuel?	Replace with correct type of fuel.
	Cooling fins dirty?	Clean cooling fins.
Rotational speed fluctuates.	Governor adjusted correctly?	Adjust governor
	Governor spring defective?	Replace governor spring.
	Fuel flow restricted?	Check entire fuel system for leaks or clogs.
Recoil starter malfunction.	Recoil mechanism clogged with dust and dirt?	Clean recoil assembly with soap and water.
	Spiral spring loose?	Replace spiral spring.

TROUBLESHOOTING

Table 7. Generator Troubleshooting

Symptom	Possible Problem	Solution
Low voltage	Engine speed too low?	Raise engine speed to rated RPM.
Low voltage. Engine speed normal 3650 RPM (unloaded), 2500 RPM (idle)	AC voltmeter not working?	Replace Ac voltmeter.
	Control box internal wiring malfunction?	Check control box wiring.
	Defective ignition coil?	Check red and green ignition wires. Replace ignition wires if necessary.
	Rotor winding malfunction?	Check or replace rotor.
	Stator winding malfunction?	Check or replace stator.
	Leakage breaker malfunction?	Check or replace CB1.
	Full power switch malfunction?	Check full power switch and full power switch circuit.
Voltage output too high.	Engine speed too high?	Lower engine speed to rated RPM.
Voltage output too high. Engine speed normal 3650 RPM (unloaded), 2500 RPM (idle)	Control box internal wiring malfunction	Check control box wiring.
Circuit breaker will not turn on "NO LOAD"	Defective circuit breaker?	Replace circuit breaker.
Circuit breaker will turn on "LOADED" but trips immediately.	Overload Condition?	Reduce load or replace breaker.
	Load circuit is shorted?	Check load circuit for short.
Does not accelerate from low to high "NO LOAD"	Stuck solenoid?	Check solenoid.
	Bad Idle control switch?	Check or replace idle control switch.
Does not accelerate from low to high "LOAD ACTIVE"	Idle control switch malfunction?	Check or replace idle control switch.
	Idle control device malfunction?	Check or replace idle control device.
	Control box internal wiring defective?	Check control box wiring.
Does not decelerate no "VOLTAGE OUTPUT".	Defective rotor windings?	Check or replace rotor.
	Defective solenoid?	Check or replace solenoid.
	Defective idle control device?	Check or replace idle control device.
	Defective solenoid?	Check or replace idle control device.
Does not decelerate but has "VOLTAGE OUTPUT".	Control box wiring malfunction?	Check control box wiring, replace any defective components.
	Defective solenoid?	Check or replace solenoid.
	Idle control device malfunction?	Check or replace idle control device.

EXPLANATION OF CODE IN REMARKS COLUMN

The following section explains the different symbols and remarks used in the Parts section of this manual. Use the help numbers found on the back page of the manual if there are any questions.

NOTICE

The contents and part numbers listed in the parts section are subject to change **without notice**. Multiquip does not guarantee the availability of the parts listed.

SAMPLE PARTS LIST

NO.	PART NO.	PART NAME	QTY.	REMARKS
1	12345	BOLT.....	1	INCLUDES ITEMS W/%
2%		WASHER, 1/4 IN.....		NOT SOLD SEPARATELY
2%	12347	WASHER, 3/8 IN....	1	MQ-45T ONLY
3	12348	HOSE	A/R	MAKE LOCALLY
4	12349	BEARING	1	S/N 2345B AND ABOVE

NO. Column

Unique Symbols — All items with same unique symbol

(@, #, +, %, or >) in the number column belong to the same assembly or kit, which is indicated by a note in the “Remarks” column.

Duplicate Item Numbers — Duplicate numbers indicate multiple part numbers, which are in effect for the same general item, such as different size saw blade guards in use or a part that has been updated on newer versions of the same machine.

NOTICE

When ordering a part that has more than one item number listed, check the remarks column for help in determining the proper part to order.

PART NO. Column

Numbers Used — Part numbers can be indicated by a number, a blank entry, or TBD.

TBD (To Be Determined) is generally used to show a part that has not been assigned a formal part number at the time of publication.

A blank entry generally indicates that the item is not sold separately or is not sold by Multiquip. Other entries will be clarified in the “Remarks” Column.

QTY. Column

Numbers Used — Item quantity can be indicated by a number, a blank entry, or A/R.

A/R (As Required) is generally used for hoses or other parts that are sold in bulk and cut to length.

A blank entry generally indicates that the item is not sold separately. Other entries will be clarified in the “Remarks” Column.

REMARKS Column

Some of the most common notes found in the “Remarks” Column are listed below. Other additional notes needed to describe the item can also be shown.

Assembly/Kit — All items on the parts list with the same unique symbol will be included when this item is purchased.

Indicated by:

“INCLUDES ITEMS W/(unique symbol)”

Serial Number Break — Used to list an effective serial number range where a particular part is used.

Indicated by:

“S/N XXXXX AND BELOW”

“S/N XXXX AND ABOVE”

“S/N XXXX TO S/N XXX”

Specific Model Number Use — Indicates that the part is used only with the specific model number or model number variant listed. It can also be used to show a part is NOT used on a specific model or model number variant.

Indicated by:

“XXXXX ONLY”

“NOT USED ON XXXX”

“Make/Obtain Locally” — Indicates that the part can be purchased at any hardware shop or made out of available items. Examples include battery cables, shims, and certain washers and nuts.

“Not Sold Separately” — Indicates that an item cannot be purchased as a separate item and is either part of an assembly/kit that can be purchased, or is not available for sale through Multiquip.

SUGGESTED SPARE PARTS

GAC2.2H PORTABLE 60 HZ GENERATOR WITH HONDA GX160K1EMA2/ GX160U1EMAN GASOLINE ENGINES

1 to 3 units

Qty.	P/N	Description
10810106004.....	CAP FUEL TANK
10810107103.....	FILTER FUEL
47935419204.....	RUBBER SUSPENSION
47935419304.....	RUBBER SUSPENSION
39807956846.....	SPARK PLUG
1◆34150ZH7003.....	SWITCH ASSY., OIL ALERT
1◇34150ZH7013.....	SWITCH ASSY., OIL ALERT
228462ZH8003.....	ROPE, RECOIL
317211ZB2000.....	ELEMENT AIR CLEANER

NOTICE

Part numbers on this Suggested Spare Parts list may supersede/replace the part numbers shown in the following parts lists.

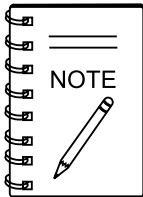

◆GX160K1EMA2: Model GAC2.2H, JUNE 2006 AND BELOW

◇GX160U1EMAN: Model GAC2.2H, FEBRUARY 2007 AND ABOVE

NAMEPLATE AND DECALS

S/N 5560983 AND BELOW

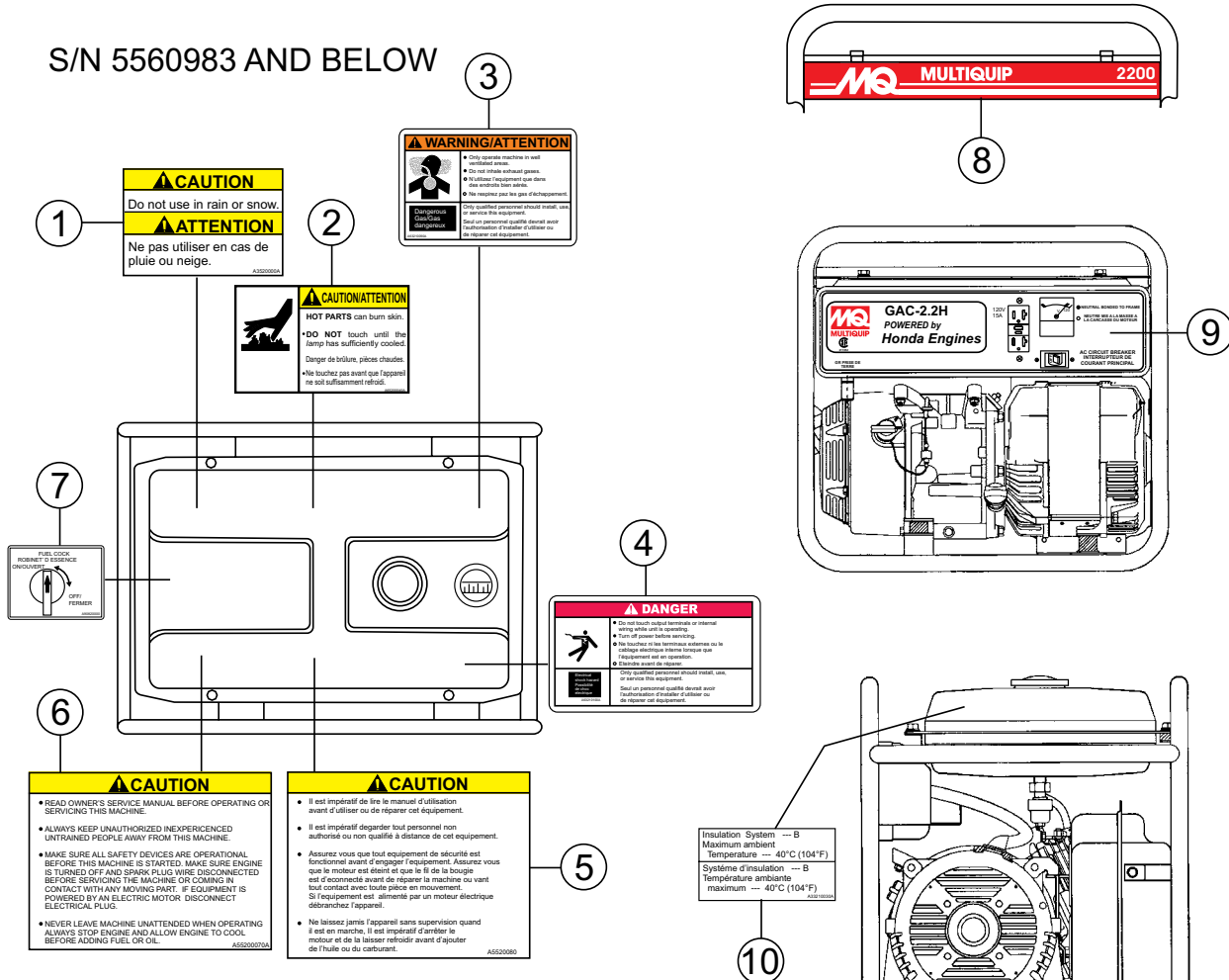

S/N 5560984~ 5582067

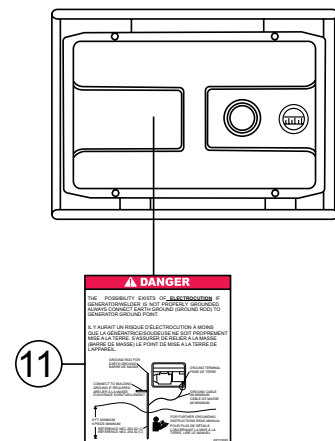

S/N 5582068~ 5623308

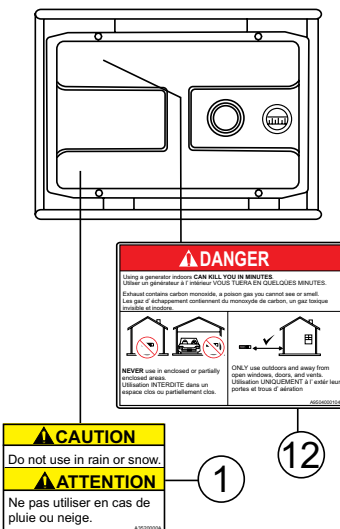

S/N 5623309 AND ABOVE

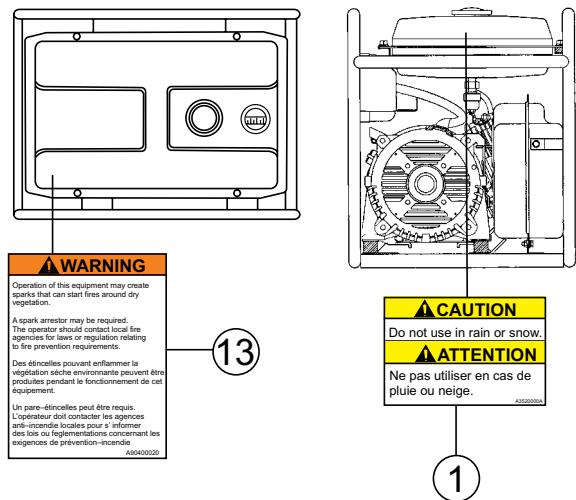

NAMEPLATE AND DECALS

<u>NO.</u>	<u>PART NO.</u>	<u>PART NAME</u>	<u>QTY.</u>	<u>REMARKS</u>
1	A3552000004A	DECAL; CAUTION, RAIN SNOW.....	1.....	A35200000A
2	A6552000404A	DECAL; CAUTION, HOT PARTS	1.....	A65300040A
3	A6532100904A	DECAL; WARNING, EXHAUST GASES	1.....	A63210090A
4	A6532101004A	DECAL; DANGER, ELECTROCUTION	1.....	A63210100A
5	A5552000804	DECAL; OPERATING INSTR. (FRENCH).....	1.....	A552200080
6	A5552000704A	DECAL; OPERATING INSTR. (ENGLISH).....	1.....	A55200070A
7	A9508200004	DECAL; FUEL COCK.....	1.....	A90820000
8	A1562000803	DECAL; MQ LOGO 2200 STRIPE.....	1.....	A16200080
9	A2512100112	DECAL; FRONT NAMEPLATE GAC2.2H	1.....	A21210011
10	A3532100304A	DECAL; SPECIFICATION	1.....	A33210030A
11	A9511100204	DECAL; DANGER, GROUND ROD	1.....	A91110020
			S/N 5560984-5582067
12	A9504000104	DECAL; DANGER, DANGEROUS GASES.....	1.....	A90400010
			S/N 5582068-5623308
13	A9504000204	DECAL; WARNING, SPARK ARRESTOR.....	1.....	A90400020
			S/N 5623309 AND ABOVE

GENERATOR ASSY.

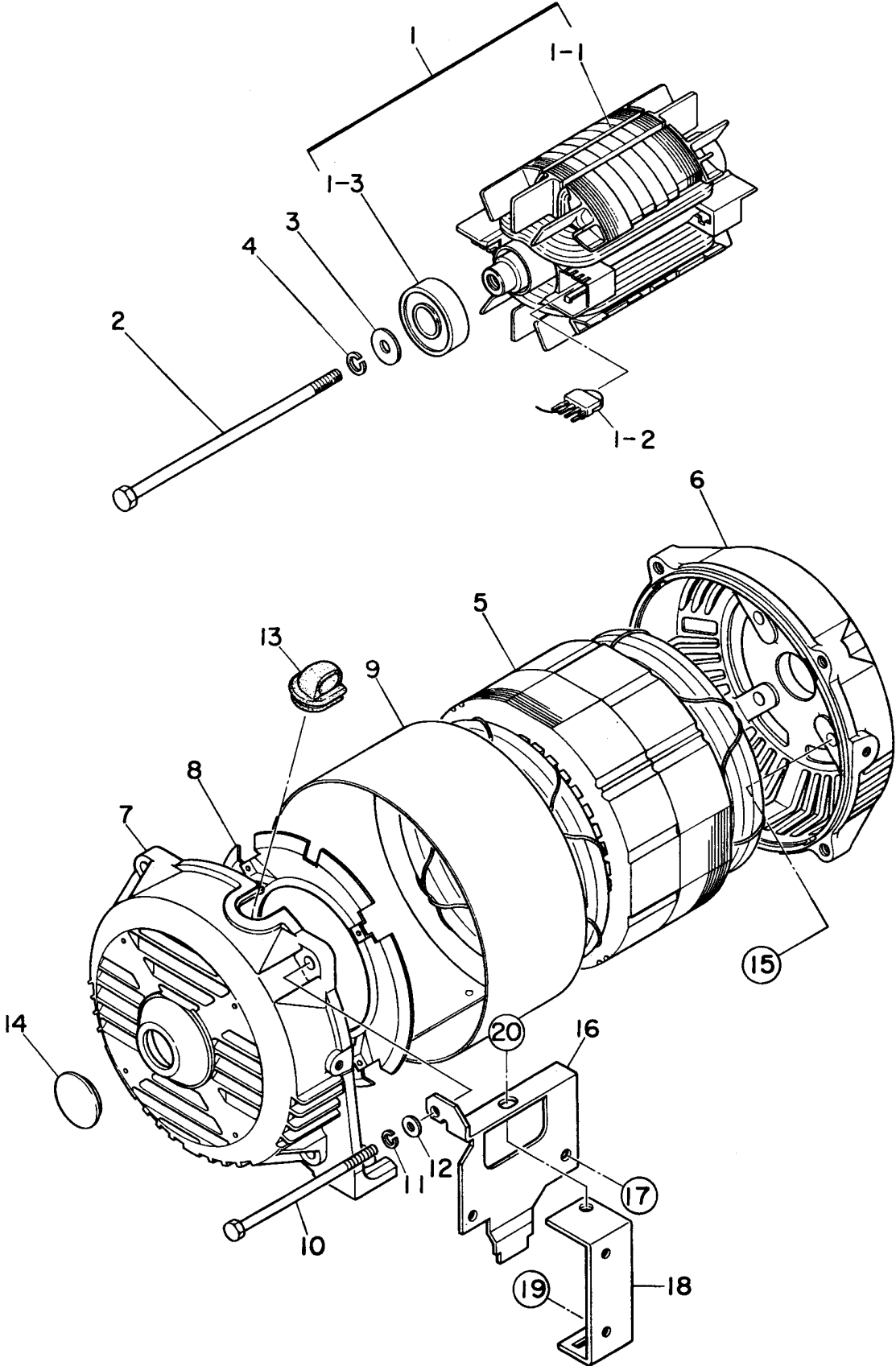

GENERATOR ASSY.

<u>NO.</u>	<u>PART NO.</u>	<u>PART NAME</u>	<u>QTY.</u>	<u>REMARKS</u>
1	7931000203	ROTOR ASSY.	1	
1-1	7681080003	FIELD COIL	1	
1-2	0601823213	RECTIFIER	2	
	0601822637	SURGE ABSORBER	2	
1-3	0603000040	BEARING	1	
2	7681017104	SET BOLT, ROTOR	1	
3	0801086004	SET WASHER, BEARING	1	
4	0040008000	WASHER, LOCK	1	
5	A2136000503	ARMATURE ASSY.	1	
6	7931315002	END BRACKET	1	
7	7931315102	END BRACKET	1	
8	7875021523	GUIDE PANEL, AIR	1	
9	7681331003	COVER	1	
10	7681344204	SET BOLT, STATOR	4	
11	0040006000	WASHER, LOCK	4	
12	0041206000	WASHER, FLAT	4	
13	7871329514	GROMMET	1	
14	0601851760	CAP	1	
15	0017408020	HEX. HEAD BOLT	4	
16	7935420104	STAY, MUFFLER	1	
17	0021806010	MACHINE SCREW	2	
18	7935420004	STAY, MUFFLER	1	
19	0207206000	HEX. NUT	2	
20	0017108020	HEX. HEAD BOLT	1	

CONTROL BOX ASSY.

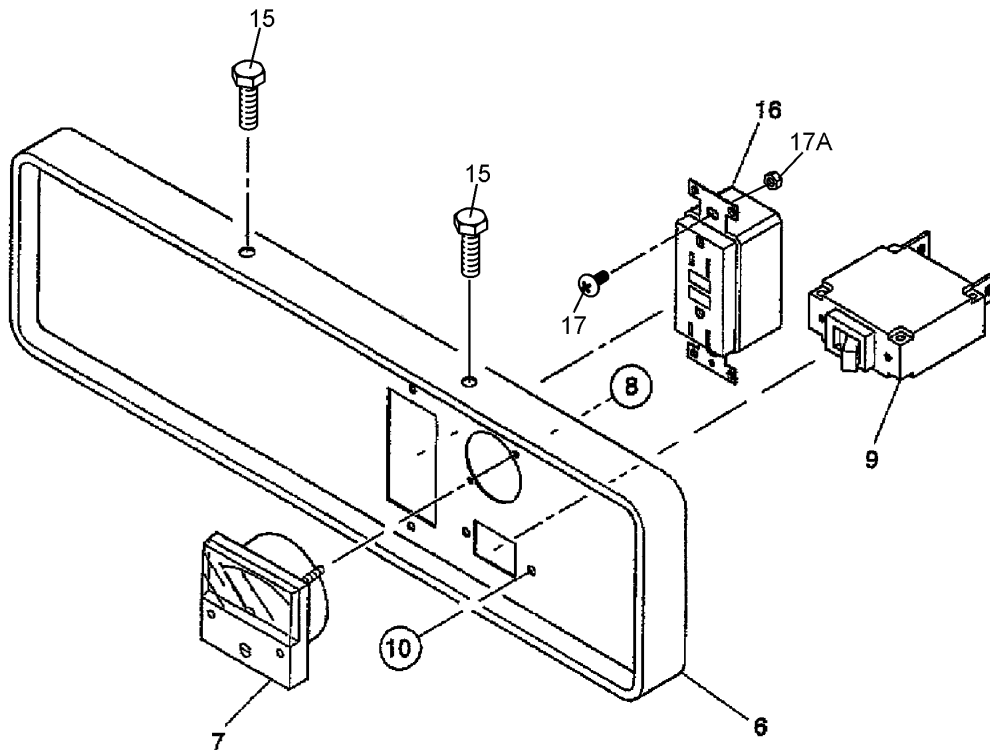
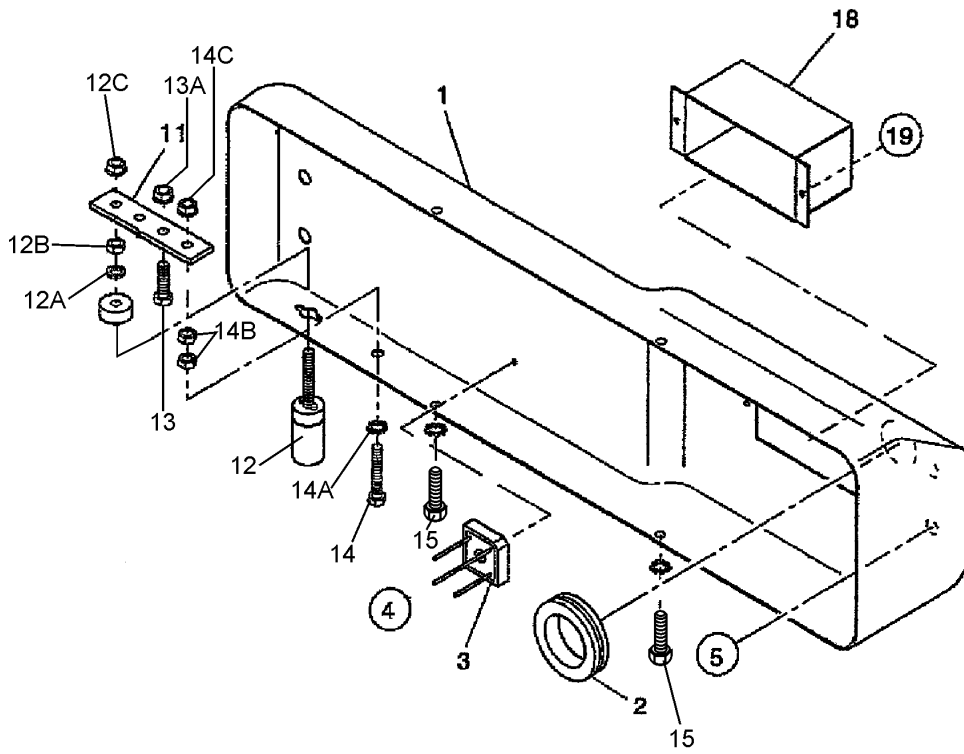

CONTROL BOX ASSY.

<u>NO.</u>	<u>PART NO.</u>	<u>PART NAME</u>	<u>QTY.</u>	<u>REMARKS</u>
1	A2215000103	CONTROL BOX	1	
2	0301850215	GROMMET	1	
3	0601823204	RECTIFIER	1	
4	0027103020	MACHINE SCREW	2	
5	0017106015	HEX.HEAD BOLT	4	
6	A2225000503	CONTROL PANEL	1	
7	0601806867	AC VOLTMETER	1	
8	0038303000	HEX NUT	2	
9	0601807462	CIRCUIT BREAKER, 15A 250V	1	
10	0027104010	MACHINE SCREW	2	
11	A3262800104	TERMINAL PLATE	1	
12	0601815147	GROUND TERMINAL	1	
12A	0040005000	WASHER, LOCK	1	
12B	0031005000	HEX NUT	1	
12C	0038305000	HEX NUT	1	
13	0010005025	HEX HEAD BOLT	1	
13A	0038305000	HEX NUT	1	
14	0010005040	HEX HEAD BOLT	1	
14A	0040505000	TOOTHED WASHER	1	
14B	0031005000	HEX NUT	2	
14C	0038305000	HEX. NUT	1	
15	0017105010	HEX HEAD BOLT	4	
15A	0040505000	TOOTHED WASHER	2	
16	0601812590	RECEPTACLE, 515R GF5252	1	
17	0027104016	MACHINE SCREW	2	
17A	0038304000	HEX NUT	2	
18	A2225200004	CB COVER	1	
19	0027103010	MACHINE SCREW	2	

PIPE FRAME ASSY.

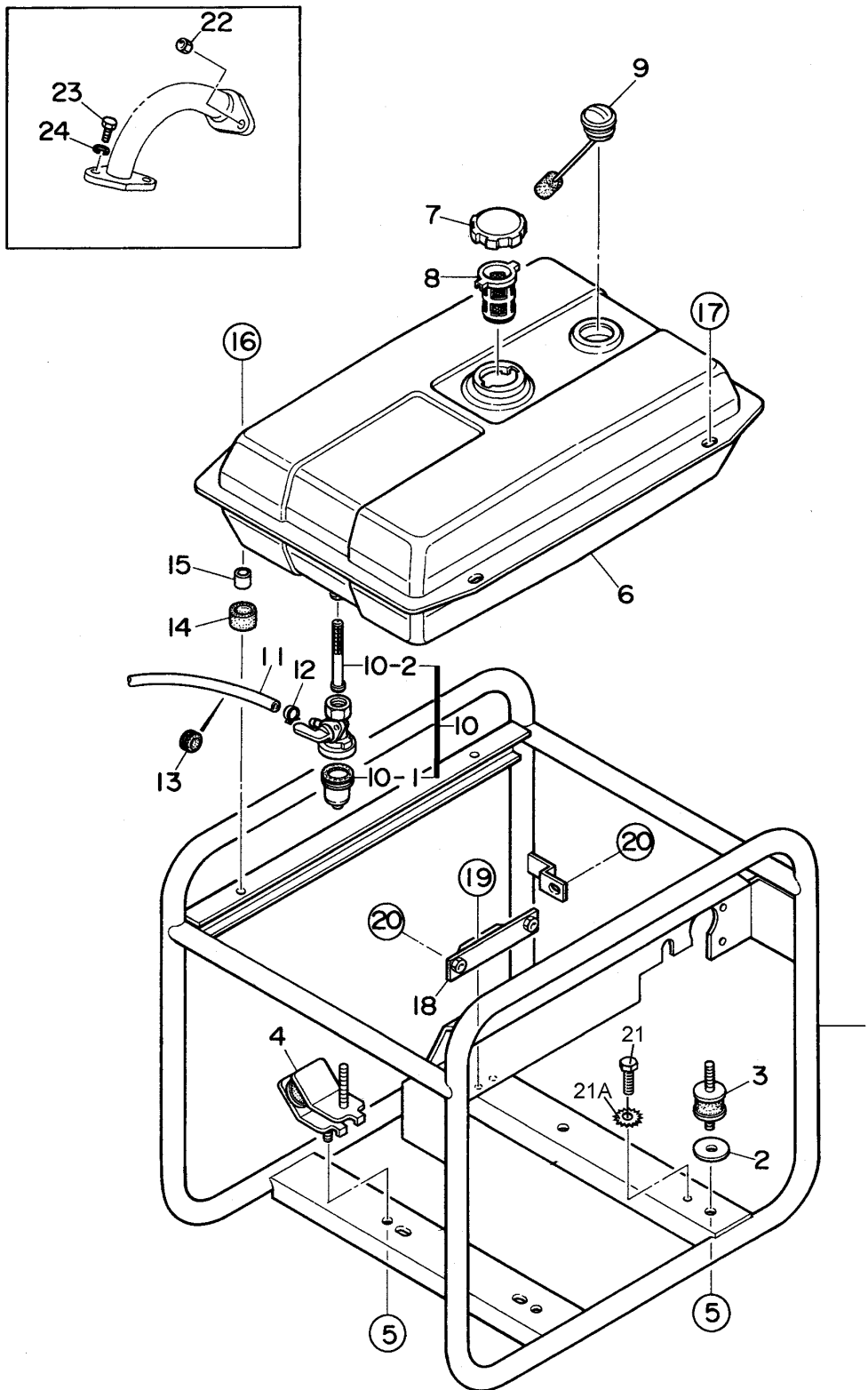

PIPE FRAME ASSY.

<u>NO.</u>	<u>PART NO.</u>	<u>PART NAME</u>	<u>QTY.</u>	<u>REMARKS</u>
1	A2418000202	PIPE FRAME	1	
2	0801886104	WASHER	2	
3	7935419204	RUBBER SUSPENSION	2	
4	7935419304	RUBBER SUSPENSION	2	
5	0207208000	HEX NUT	8	
6	7935510102	FUEL TANK	1	
7	0810106004	CAP FUEL TANK	1	
8	0810107103	FUEL FILTER	1	
9	0602125034	FUEL GAUGE	1	
10	0605510065	FUEL STRAINER.....	1.....	INCLUDES ITEMS W/#
		REPLACES P/N 0605510065
10-1#	16950898633	CUP	1.....	REPLACES P/N 0605510066
10-2#	16952883005	FILTER	1.....	REPLACES P/N 0605510067
11	950014500160M	HOSE.....	1.....	REPLACES P/N 0605513141
12	9500202080	HOSE BAND.....	2.....	REPLACES P/N 0605515188
13	90854ZB2000	GROMMET	1.....	REPLACES P/N 0601851775
14	7855525514	RUBBER WASHER	2	
15	7855525604	COLAR	2	
16	0017108030	HEX HEAD BOLT	2	
17	0017108020	HEX HEAD BOLT	2	
18	7935421004	BRACKET, MUFFLER COVER	1	
19	0017106016	HEX HEAD BOLT	2	
20	0017106016	HEX HEAD BOLT	3	
21	0017106016	HEX HEAD BOLT	1	
21A	0040506000	TOOTHED WASHER	1	
22	0031308000	HEX NUT	2	
23	0011308020	HEX HEAD BOLT	2	
24	0040008000	WASHER, LOCK	2	

HONDA GX160K1EMA2/U1EMAN ENGINE — CYL. HD ASSY.

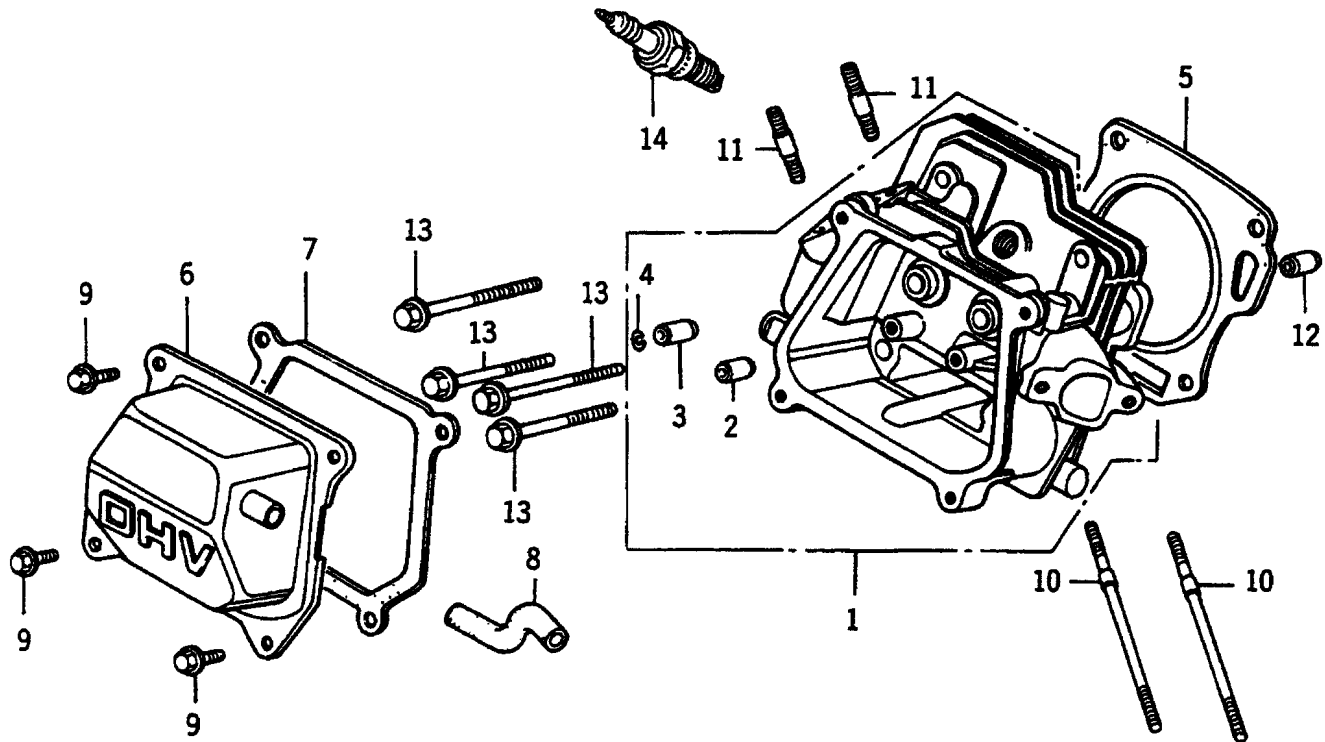

HONDA GX160K1EMA2/U1EMAN ENGINE — CYL. HD ASSY.

NO.	PART NO.	PART NAME	QTY.	REMARKS
1◆	12210ZH8020	HEAD COMP, CYLINDER.....	1.....	INCLUDES ITEMS W/#
1◇	12210ZH8415	HEAD COMP, CYLINDER.....	1.....	INCLUDES ITEMS W/#
2#	12204ZE1306	GUIDE, IN. VALVE (OVER SIZE)	1	
3#	12205ZE1315	GUIDE, IN. VALVE	1	
4#	12216ZE5300	CLIP, VALVE GUIDE	1	
5	12251ZF1800	GASKET, CYLINDER HEAD	1	
6◆	12310ZE1010	COVER COMP, HEAD	1	
6◇	12310ZE1020	COVER COMP, HEAD	1	
7	12391ZE1000	PACKING, HEAD COVER	1	
8◆	15721732000	TUBE, BREATHER	1	
8◇	15721883030	TUBE, BREATHER	1	
9	90013883000	BOLT, FLANGE 6X12	4	
10	90043ZB2003	BOLT, STUD 6X94	2	
11	90047ZE1000	BOLT, STUD 8X32	2	
12	9430110160	PIN, DOWEL 10X16	2	
13	957230806000	BOLT, FLANGE 8X60	4	
14	9807956846	PLUG, SPARK (BPR6ES NGK)	1	
14	9807956855	PLUB, SPARK (W20EPR-U ND)	1	

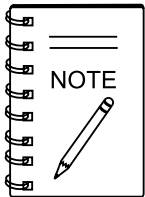

◆GX160K1EMA2: Model GAC2.2H, JUNE 2006 AND BELOW

◇GX160U1EMAN: Model GAC2.2H, FEBUARY 2007 AND ABOVE

HONDA GX160K1EMA2/U1EMAN ENGINE — CYL. BARREL ASSY.

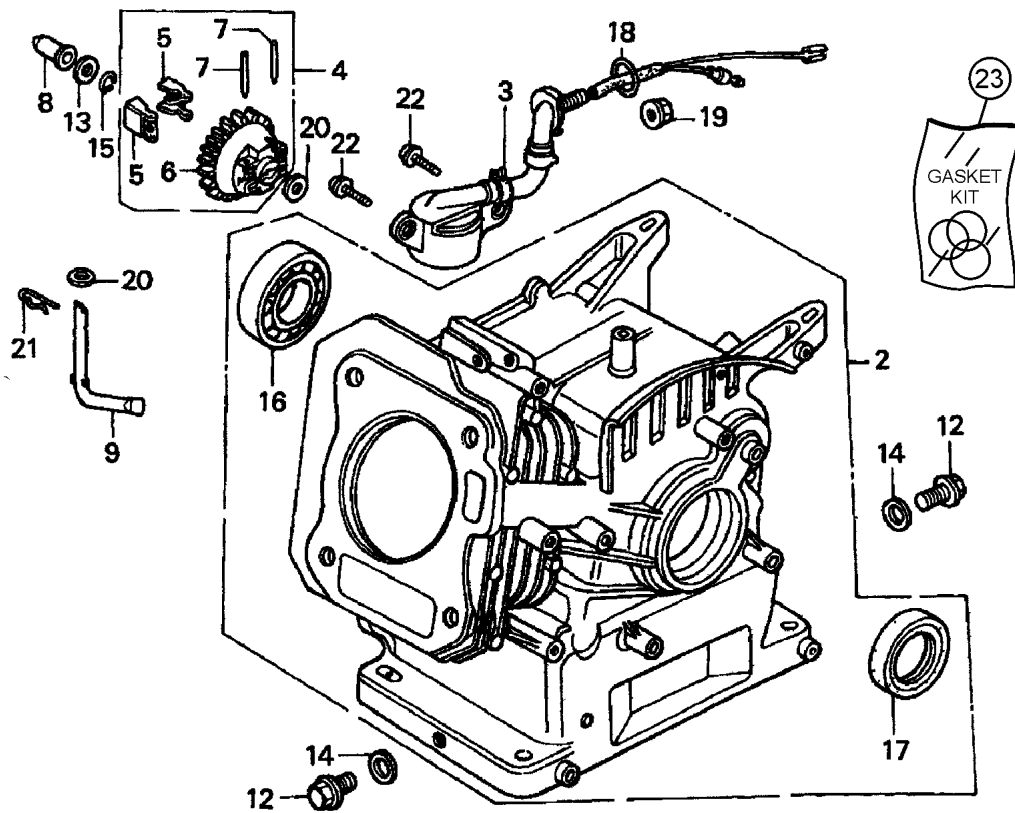

HONDA GX160K1EMA2/U1EMAN ENGINE — CYL. BARREL ASSY.

NO.	PART NO.	PART NAME	QTY.	REMARKS
2◆	12000ZH8406	BARREL ASSY, CYLINDER (OIL ALERT).....	1.....	INCLUDES ITEMS W/#
2◇	12000ZH8426	BARREL ASSY, CYLINDER (OIL ALERT).....	1.....	INCLUDES ITEMS W/#
3◆	15510ZE1033	SWITCH ASSY, OIL LEVEL	1	
3◇	15510ZE1043	SWITCH ASSY, OIL LEVEL	1	
4◆	16510ZE1000	GOVERNOR ASSY.	1.....	USE UP TO S/N 4913229INCLUDES ITEMS W/%
4◆	16506ZL0000	GOVERNOR ASSY.	1.....	USE FROM S/N 4913230INCLUDES ITEMS W/%
4◇	16506ZL0000	GOVERNOR ASSY.	1.....	INCLUDES ITEMS W/%
5%◆	16511ZE1000	WEIGHT, GOVERNOR	2	
6%◆	16512ZE1000	HOLDER, GOVENOR WEIGHT	1	
7%◆	16513ZE1000	PIN, GOVERNOR WEIGHT	2	
8	16531ZE1000	SLIDER, GOVERNOR	1	
9	16541ZE1000	SHAFT, GOVERNOR ARM	1	
12	90131ZE1000	BOLT, DRAIN PLUG	2	
13	90451ZE1000	WASHER, THRUST 6MM	1	
14	90601ZE1000	WASHER, DRAIN PLUG 10.2MM	2	
15	90602ZE1000	CLIP, GOVERNOR HOLDER	1	
16#	91001ZF1003	BEARING, RADIAL BALL (6205TMB)	1	
17#	91201Z0T801	OIL SEAL 25X41X6	1	
18	91353671004	O-RING, 13.5X1.5	1	
19	9405010000	NUT, FLANGE, 10MM	1	
20	9410106800	WASHER, PLAIN, 6MM	2	
21	9425108000	PIN, LOCK, 8MM	1	
22	957010601200	BOLT, FLANGE, 6X12	2	
23	06111ZH8405	GASKET KIT	1	



◆GX160K1EMA2: Model GAC2.2H, JUNE 2006 AND BELOW

◇GX160U1EMAN: Model GAC2.2H, FEBRUARY 2007 AND ABOVE

HONDA GX160K1EMA2/U1EMAN ENGINE — CRANKCASE CVR. ASSY.

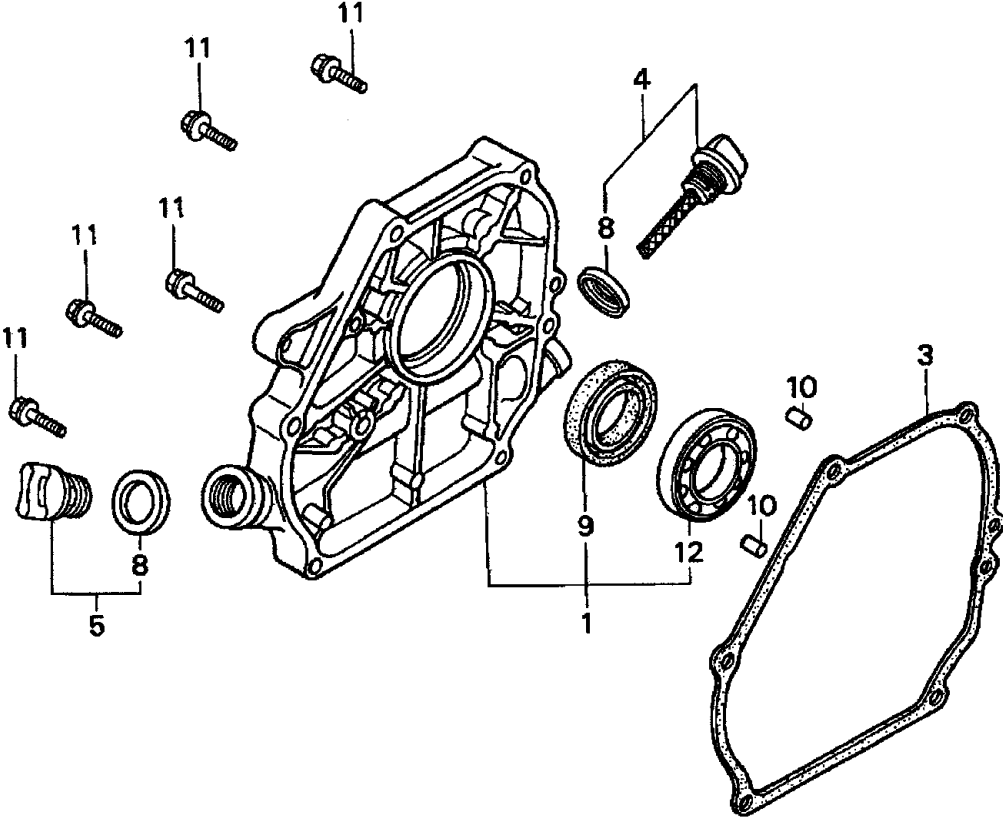

HONDA GX160K1EMA2/U1EMAN ENGINE — CRANKCASE CVR. ASSY.

<u>NO.</u>	<u>PART NO.</u>	<u>PART NAME</u>	<u>QTY.</u>	<u>REMARKS</u>
1	11300ZE1634	COVER ASSY, CRANKCASE	1.....	INCLUDES ITEMS W/%
3	11381ZH8801	GASKET, CASE COVER	1	
4	15600ZE1003	CAP ASSY, OIL FILLER.....	1.....	INCLUDES ITEMS W/#
5	15600ZG4003	CAP, OIL FILLER	1	
8#	15625ZE1003	GASKET, OIL FILLER CAP	1	
9%	91201ZOT801	OIL SEAL, 25X41X6	1	
10	9430108140	PIN, DOWEL 8X14	2	
11	957010803200	BOLT, LANGE 8X32	6	
12%	961006205000	BEARING, RADIAL BALL, 6205	1	

HONDA GX160K1EMA2/U1EMAN ENGINE — CRANKSHAFT ASSY.

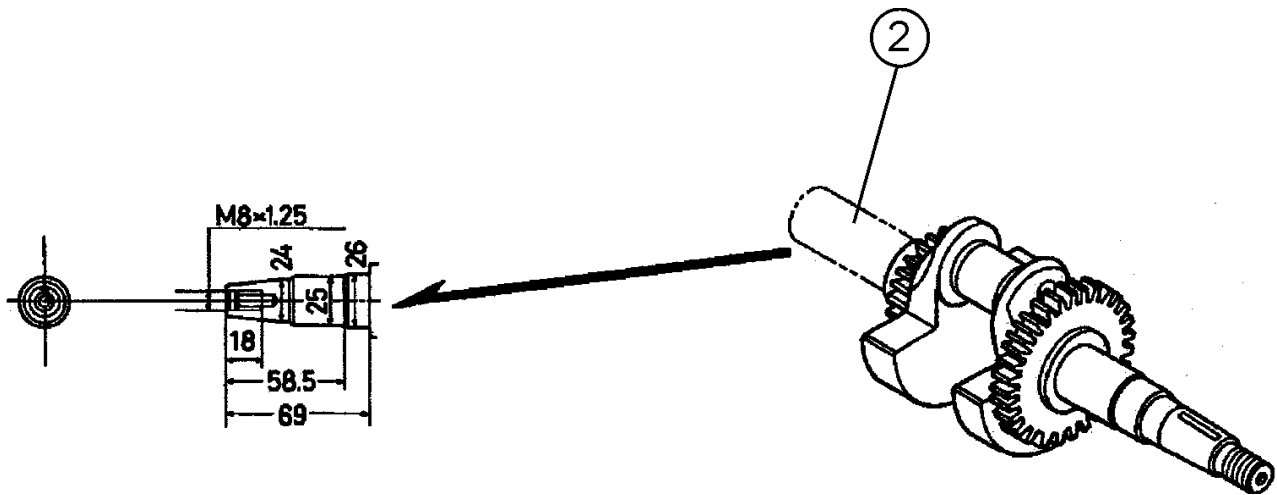

HONDA GX160K1EMA2/U1EMAN ENGINE — CRANKSHAFT ASSY.

<u>NO.</u>	<u>PART NO.</u>	<u>PART NAME</u>	<u>QTY.</u>	<u>REMARKS</u>
1	13310ZB2000	CRANKSHAFT COMP.	1	

HONDA GX160K1EMA2/U1EMAN ENGINE — PISTON ASSY.

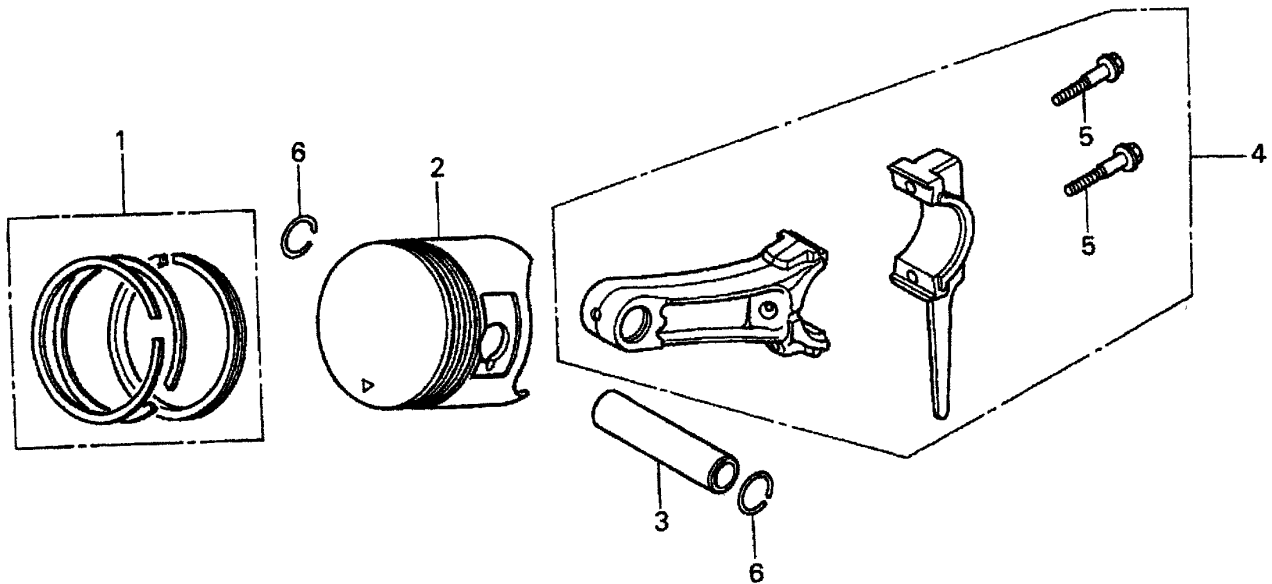

HONDA GX160K1EMA2/U1EMAN ENGINE — PISTON ASSY.

<u>NO.</u>	<u>PART NO.</u>	<u>PART NAME</u>	<u>QTY.</u>	<u>REMARKS</u>
1◆	13010ZF1023	RING SET, PISTON (STD)	1	
1◇	13010Z4K004	RING SET, PISTON (STD)	1	
1◆	13011ZF1023	RING SET, PISTON (0.25)	1	
1◇	13011Z4K004	RING SET, PISTON (0.25)	1	
1◆	13012ZF1023	RING SET, PISTON (0.50)	1	
1◇	13012Z4K004	RING SET, PISTON (0.50)	1	
1◆	13013ZF1023	RING SET, PISTON (0.75)	1	
1◇	13013Z4K004	RING SET, PISTON (0.75)	1	
2	13101ZH8010	PISTON (STD)	1	
2	13102ZH8010	PISTON (0.25)	1	
2◆	13103ZH8000	PISTON (0.50)	1	
2◇	13103ZH8010	PISTON (0.50)	1	
2◆	13102ZH8010	PISTON (0.75)	1	
2◇	13104ZH8010	PISTON (0.75)	1	
3	13111ZE1000	PIN, PISTON	1	
4	13200ZE1010	ROD ASSY, CONNECTING	1	
5	90001ZE1000	BOLT, CONNECTING ROD	2	
6	90551ZE1000	CLIP, PISTON PIN, 18MM	2	

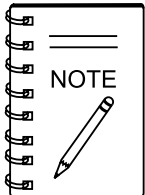

◆GX160K1EMA2: Model GAC2.2H, JUNE 2006 AND BELOW

◇GX160U1EMAN: Model GAC2.2H, FEBRUARY 2007 AND ABOVE

HONDA GX160K1EMA2/U1EMAN ENGINE — CAMSHAFT ASSY.

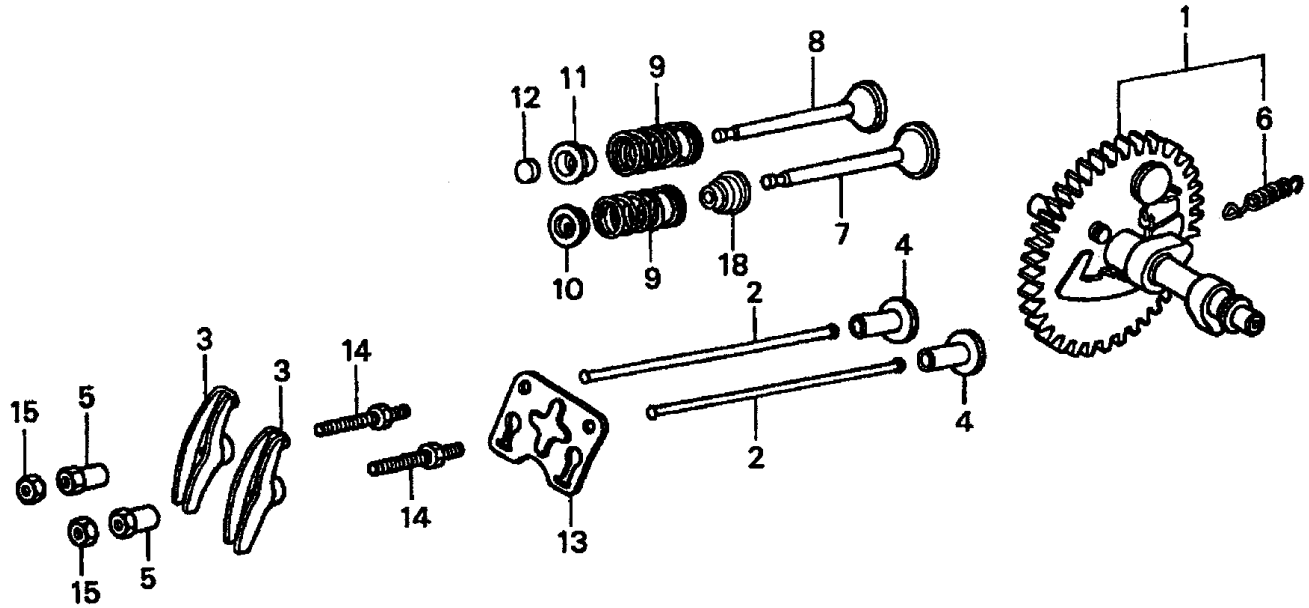

HONDA GX160K1EMA2/U1EMAN ENGINE — CAMSHAFT ASSY.

NO.	PART NO.	PART NAME	QTY.	REMARKS
1◆	14100ZE1812	CAMSHAFT ASSY.	1.....	UP TO S/N 4913229
1◆	14100ZL0000	CAMSHAFT ASSY.	1.....	FROM S/N 4913230
1◇	14100ZL0000	CAMSHAFT ASSY.	1	
2	14410ZE1010	ROD, PUSH	2	
3	14431ZE1000	ARM, VALVE ROCKER	2	
4	14441ZE1000	LIFTER, VALVE	2	
5	14451ZE1013	PIVOT, ROCKER ARM	2	
6	14568ZE1000	SPRING, WEIGHT RETURN	1	
7	14711ZF1000	VALVE, IN	1	
8	14721ZF1000	VALVE, EX	1	
9	14751ZF1000	SPRING, VALVE	2	
10	14771ZE1000	RETAINER, IN. VALVE SPRING	1	
11	14773ZE1000	RETAINER, EX. VALVE SPRING	1	
12	14781ZE1000	ROTATOR, VALVE	1	
13	14791ZE1010	PLATE, PUSH ROD GUIDE	1	
14	90012ZE0010	BOLT, PIVOT (8MM)	2	
15	90206ZE1000	NUT, PIVOT ADJUSTING	2	
18◆	12209ZH8003	VALVE STEM	1	

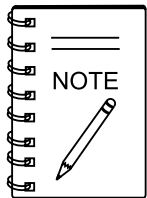

◆GX160K1EMA2: Model GAC2.2H, JUNE 2006 AND BELOW

◇GX160U1EMAN: Model GAC2.2H, FEBRUARY 2007 AND ABOVE

HONDA GX160K1EMA2/U1EMAN ENGINE — RECOIL STARTER ASSY.

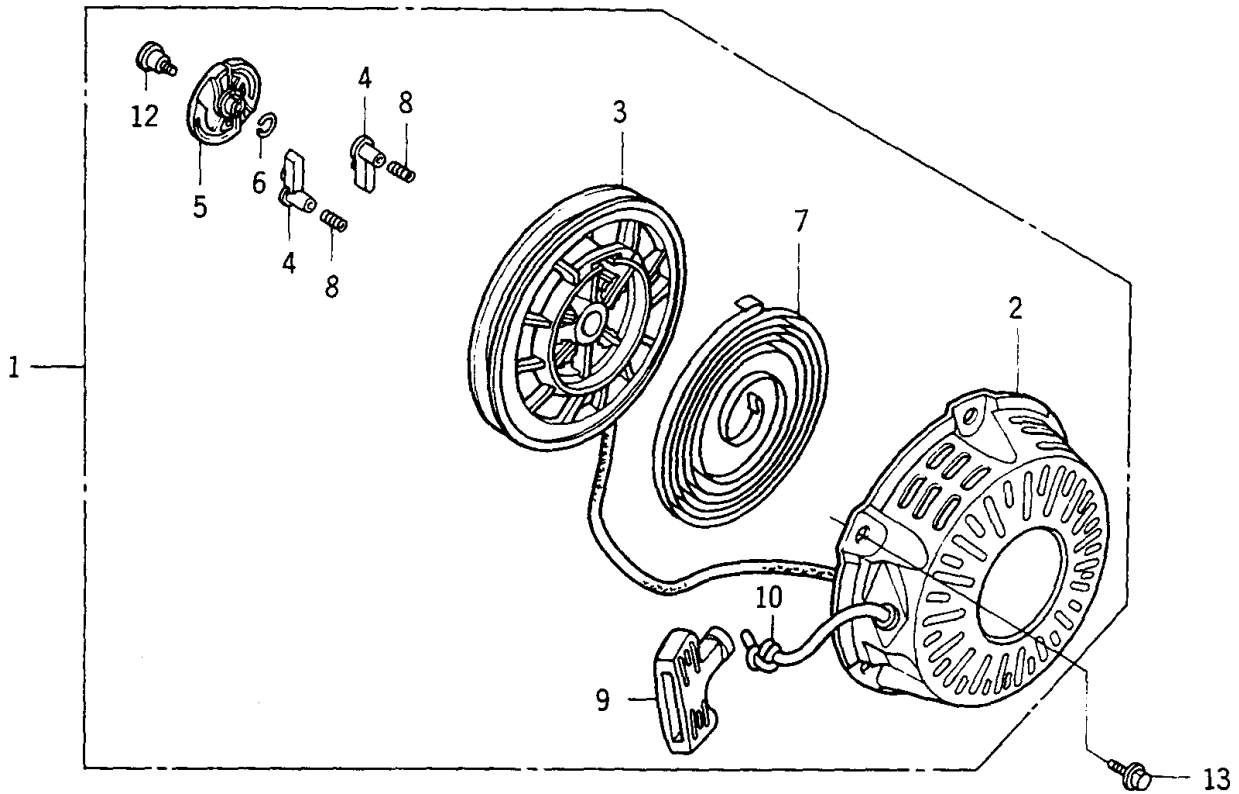

HONDA GX160K1EMA2/U1EMAN ENGINE — RECOIL STARTER ASSY.

<u>NO.</u>	<u>PART NO.</u>	<u>PART NAME</u>	<u>QTY.</u>	<u>REMARKS</u>
1◆	28400ZH8013ZB	STARTER ASSY, RECOIL "NH1" BLACK	1	
1◇	28400ZH8023ZB	STARTER ASSY, RECOIL "NH1" BLACK	1	
2	28410ZH8003ZB	CASE, RECOIL STARTER "NH1" BLACK	1	
3◆	28420ZH8013	REEL, RECOIL STARTER	1	
3◇	28421ZH8801	REEL, RECOIL STARTER	1	
4◆	28422ZH8013	RATCHET, STARTER	2	
4◇	28422ZH8801	RATCHET, STARTER	2	
5◆	28433ZH8003	GUIDE, RATCHET	1	
5◇	28433ZH8801	GUIDE, RATCHET	1	
6◆	28441ZH8003	SPRING, FRICTION	1	
6◇	28441ZH8801	SPRING, FRICTION	1	
7	28442ZH8003	SPRING, RECOIL STARTER	1	
8	28443ZH8003	SPRING, RETURN	2	
9	28461ZH8003	KNOB, RECOIL STARTER	1	
10	28462ZH8003	ROPE, RECOIL STARTER	1	
12◆	90003ZH8003	SCREW, SETTING	1	
12◇	90003ZH8801	SCREW, SETTING	1	
13	90008ZE2003	BOLT, FLANGE 6X10	3	

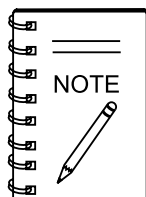

◆GX160K1EMA2: Model GAC2.2H, JUNE 2006 AND BELOW

◇GX160U1EMAN: Model GAC2.2H, FEBRUARY 2007 AND ABOVE

HONDA GX160K1EMA2/U1EMAN ENGINE — FAN COVER ASSY.

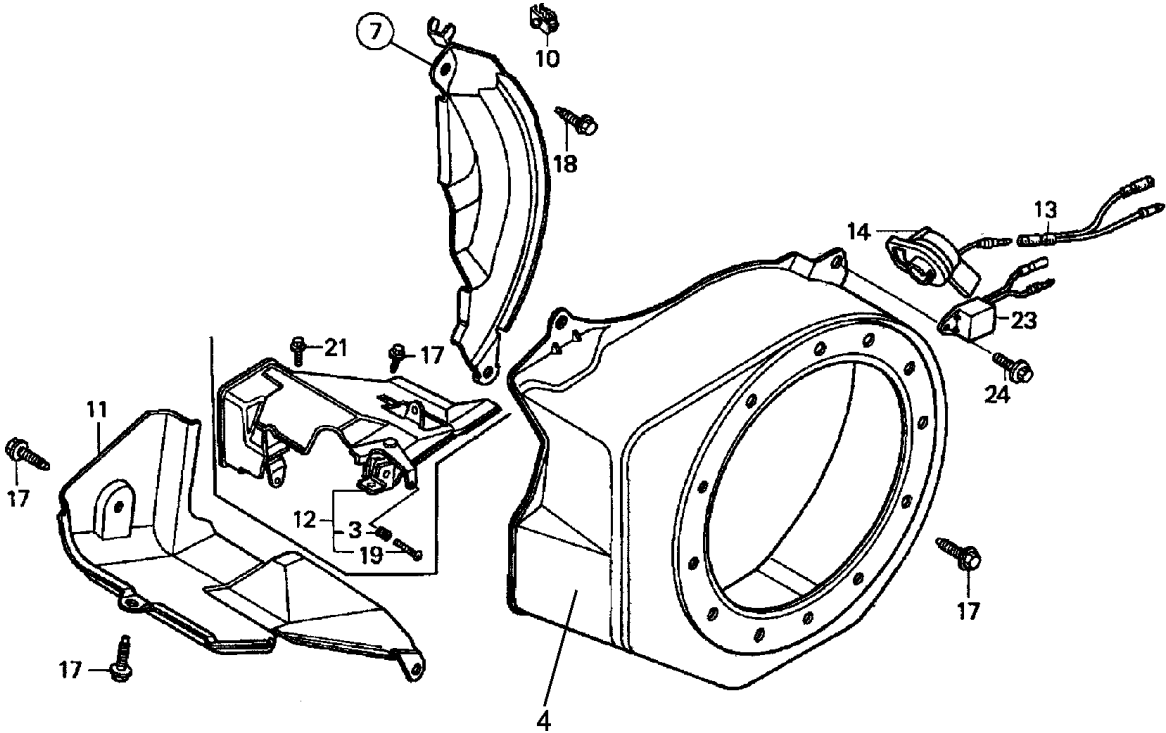

HONDA GX160K1EMA2/U1EMAN ENGINE — FAN COVER ASSY.

NO.	PART NO.	PART NAME	QTY.	REMARKS
3*	16584883300	SPRING, CONTROL ADJUSTING	1	
4	19610ZE1000ZC	COVER, FAN "NH1" BLACK	1	
7◆	19611ZH8820	PLATE, SIDE ALERT & LAMP	1	USE FROM S/N 475372719
7◆	19612ZH8821	PLATE, SIDE ALERT & LAMP	1	USE FROM S/N 4795906~537271
7◆	19612ZH8830	PLATE, SIDE ALERT & LAMP	1	USE UP TO S/N 4795905
7◇	19611ZH8820	PLATE, SIDE ALERT & LAMP	1	
10◆	19613ZE1010	CLAMP, CORD.....	1	USE UP TO S/N 4367320
10◆	90601ZH7013	CLAMP, CORD.....	1	USE FROM S/N 4367321
10◇	90601ZH7013	CLIP, HARNESS	1	
11	19630ZB2000	SHROUD COMP., LOWER	1	
12◆	19640ZB2010	SHROUD ASSY., UPPER	1	USE UP TO S/N 5048024 INCLUDES ITEMS W/#
12◆	19640ZH8R60	SHROUD ASSY., UPPER	1	USE FROM S/N 5048025 INCLUDES ITEMS W/#
12◇	19640ZH8R60	SHROUD ASSY., UPPER	1	
13◆	32197ZH8003	SUB HARNESS	1	USE UP TO S/N 4367320
14◆	36100ZE1015	ENGINE, STOP SWITCH	1	USE UP TO S/N 4368640
14◆	36100ZH7003	ENGINE, STOP SWITCH	1	USE FROM S/N 4368641
14◇	36100ZF6P81	ENGINE, STOP SWITCH	1	
17	90013883000	BOLT, FANGE 6X12	8	
18	90022888010	BOLT, FLANGE 6X20	1	
19#	93500050350A	SCREW, PAN 5X35.....	1	USE UP TO S/N 5048024
19#	93500050400G	SCREW, PAN 5X40.....	1	USE FROM S/N 5048025
21	957010600800	BOLT, FLANGE 6X8	1	
23◆	34150ZH7003	ALERT UNIT, OIL.....	1	USE FROM S/N 5372719
23◇	34150ZH7003	ALERT UNIT, OIL	1	
24◆	957010600800	BOLT, FLANGE 6X8.....	1	USE FROM S/N 5372719
24◇	957010600800	BOLT, FLANGE 6X8	1	

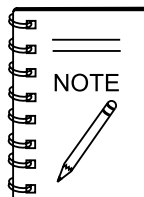

◆GX160K1EMA2: Model GAC2.2H, JUNE 2006 AND BELOW

◇GX160U1EMAN: Model GAC2.2H, FEBRUARY 2007 AND ABOVE

HONDA GX160K1EMA2/U1EMAN ENGINE — CARBURETOR ASSY.

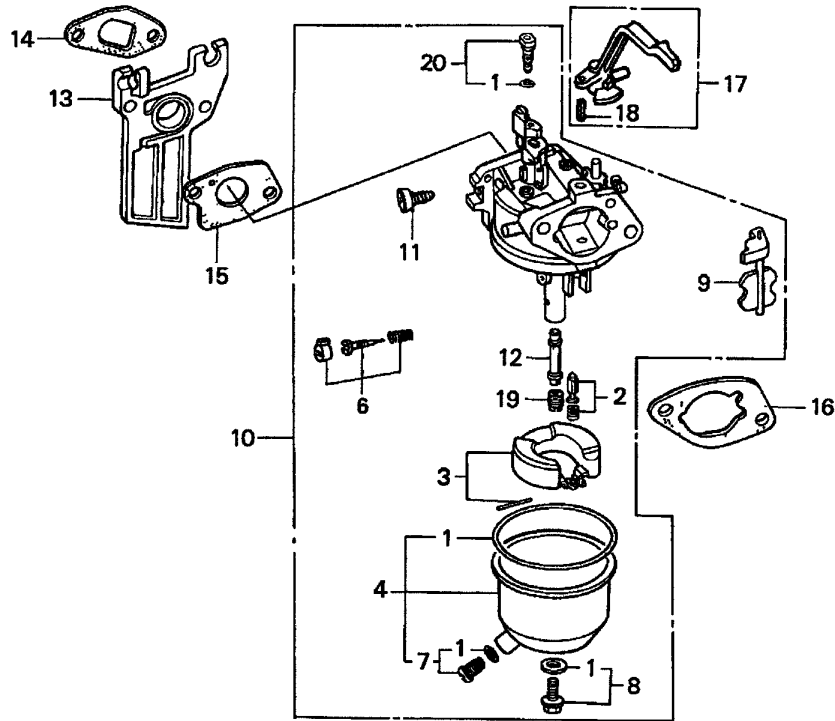

HONDA GX160K1EMA2/U1EMAN ENGINE — CARBURETOR ASSY.

NO.	PART NO.	PART NAME	QTY.	REMARKS
1#%+	16010ZB1015	GASKET SET	1	
2\$	16011ZE0005	VALVE SET, FLOAT	1	
3\$	16013ZE0005	FLOAT SET	1	
4\$◆	16015ZE0831	CHAMBER SET, FLOAT	1	USE FROM S/N BE67A A
4\$◆	16015ZE1811	CHAMBER SET, FLOAT	1	USE FROM S/N BE51A A
4\$◇	16015ZE0831	CHAMBER SET, FLOAT	1	
6\$	16016ZH7W01	SCREW SET	1	
7	16024ZE1811	SCREW SET, DRAIN	1	INCLUDES ITEMS W/%
8	16028ZE0005	SCREW SET, B.....	1	INCLUDES ITEMS W/+
9\$	16044ZE0005	CHOKE SET	1	
10◆	16100ZH8E81	CARBURETOR ASSY,(BE67A B).....	1	INCLUDES ITEMS W/\$
10◇	16100Z4JE81	CARBURETOR ASSY,(BE67P A).....	1	INCLUDES ITEMS W/\$
			USE UP TO S/N 1030721
11\$	16124ZE0005	SCREW, THROTTLE STOP	1	
12\$	16166ZH8E80	NOZZLE, MAIN	1	
13	16211ZE1000	INSULATOR, CARBURETOR	1	
14	16212ZH8800	GASKET, INSULATOR	1	
15	16221ZH8801	GASKET, CARBURETOR	1	
16	16269ZE1800	GASKET, AIR CLEANER	1	
17	16610ZB2000	LEVER COMP, CHOKE	1	INCLUDES ITEMS W/<
18<	9430520122	PIN, SPRING 2X12	1	
19	99101ZH80700	JET, MAIN, #70, OPTION	1	
19	99101ZH80720	JET, MAIN, #72, OPTION	1	
19\$	99101ZH80750	JET, MAIN, #75,	1	
20\$	99204ZE00350	JET SET, PILOT, #35	1	INCLUDES ITEMS W/#

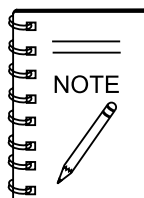

◆GX160K1EMA2: Model GAC2.2H, JUNE 2006 AND BELOW

◇GX160U1EMAN: Model GAC2.2H, FEBRUARY 2007 AND ABOVE

HONDA GX160K1EMA2/U1EMAN ENGINE — AIR CLEANER ASSY.

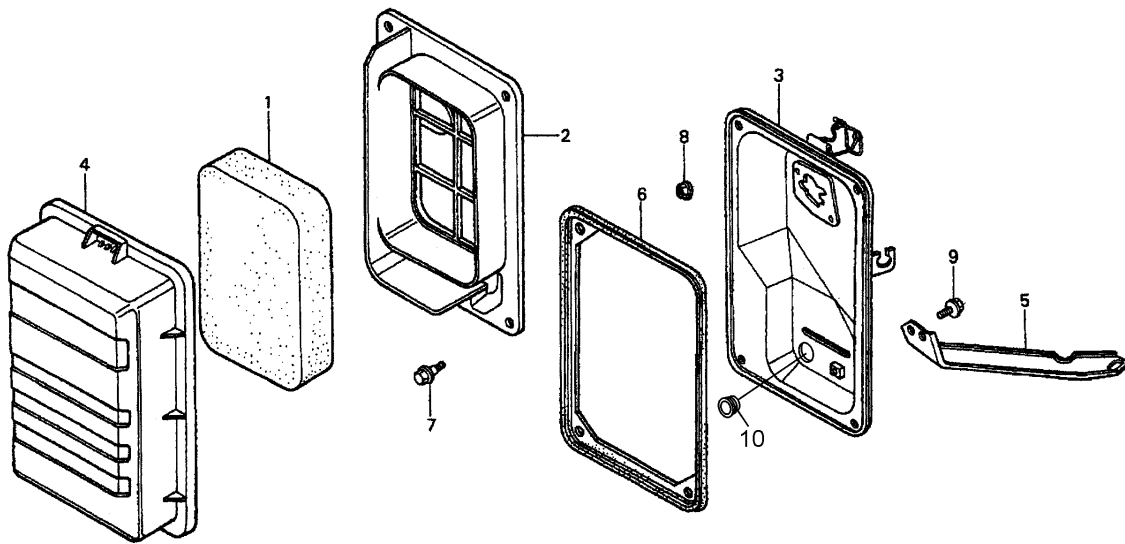

HONDA GX160K1EMA2/U1EMAN ENGINE — AIR CLEANER ASSY.

<u>NO.</u>	<u>PART NO.</u>	<u>PART NAME</u>	<u>QTY.</u>	<u>REMARKS</u>
1	17211ZB2000	ELEMENT, AIR CLEANER	1	
2◆	17212ZB2000	SEPARATOR, AIR CLEANER	1	
2◇	17212ZB2800	SEPARATOR, AIR CLEANER	1	
3◆	17220ZB2000	CASE COMP., AIR CLEANER	1	
3◇	17220ZB2800	CASE COMP., AIR CLEANER	1	
4	17231ZB2000	COVER AIR CLEANER	1	
5	17239ZB2000	STAY AIR CLEANER	1	
6	17252ZB2000	SEAL, AIR CLEANER	1	
7	90115459770	BOLT, SETTING	4	
8	9405006080	BOLT, FLANGE, 6MM	2	
9	957010601000	BOLT, FLANGE, 6X10	1	
10◇	17232898000	GROMMET, AIR CLEANER	1	



◆GX160K1EMA2: Model GAC2.2H, JUNE 2006 AND BELOW

◇GX160U1EMAN: Model GAC2.2H, FEBUARY 2007 AND ABOVE

HONDA GX160K1EMA2/U1EMAN ENGINE — MUFFLER ASSY.

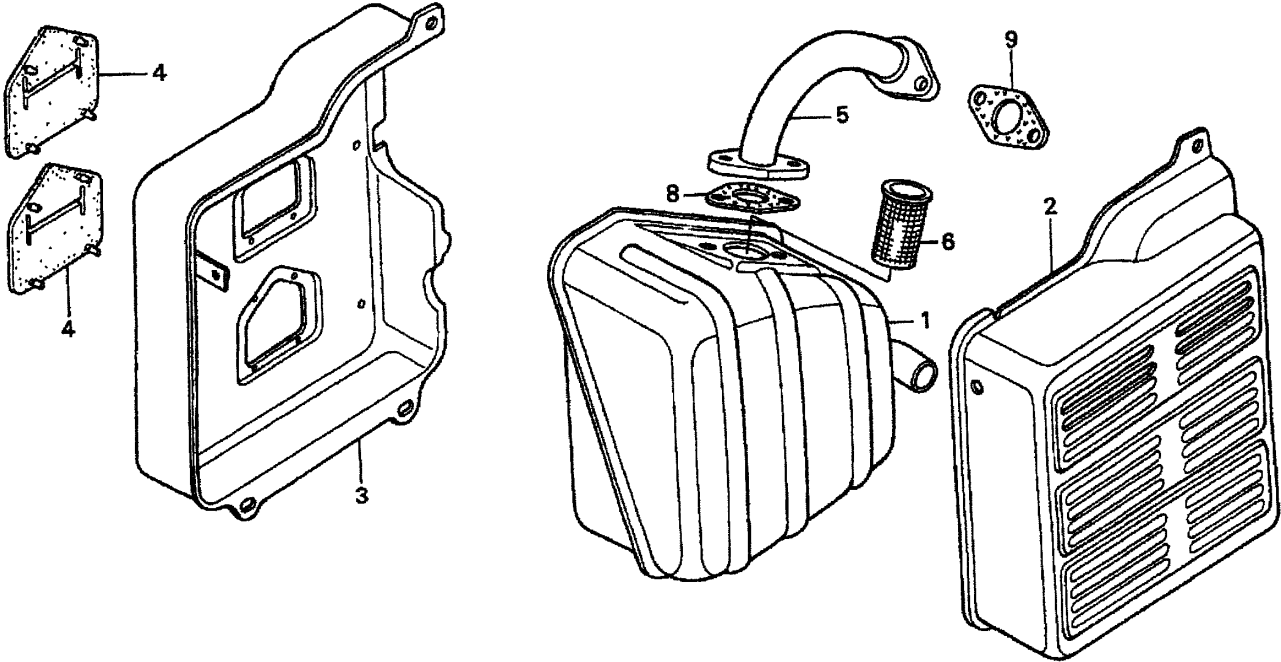

HONDA GX160K1EMA2/U1EMAN ENGINE — MUFFLER ASSY.

<u>NO.</u>	<u>PART NO.</u>	<u>PART NAME</u>	<u>QTY.</u>	<u>REMARKS</u>
1	18310ZB3C00	MUFFLER COMP.	1	
2	18320ZB2000	PROTECTOR, MUFFLER OUTER	1	
3	18325ZH8T90	PROTECTOR, MUFFLER INNER	1	
4	18329ZB2000	SEAL, MUFFLER PROTECTOR	2	
5	18330ZH8T90	PIPE COMP., EX	1	
6	18355898630	ARRESTER, SPARK	1	
8	18381ZE1800	GASKET, MUFFLER	1	
9	18381ZH8800	GASKET, MUFFLER	1	

HONDA GX160K1EMA2/U1EMAN ENGINE — FLYWHEEL ASSY.

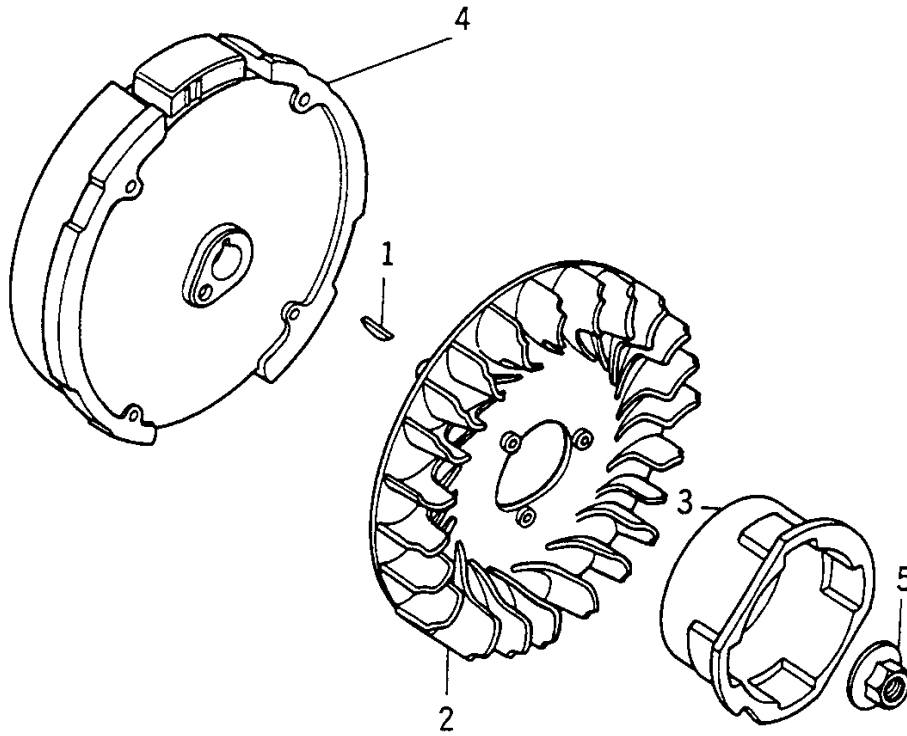

HONDA GX160K1EMA2/U1EMAN ENGINE — FLYWHEEL ASSY.

<u>NO.</u>	<u>PART NO.</u>	<u>PART NAME</u>	<u>QTY.</u>	<u>REMARKS</u>
1	13331357000	KEY, SPECIAL WOOD RUFF, 25X18	1	
2	19511ZE1000	FAN, COOLING	1	
3	28451ZH8003	PULLEY, STARTER	1	
4	31100ZE1811	FLYWHEEL (LAMP)	1	
5	90201878003	NUT, SPECIAL, 14MM	1	

HONDA GX160K1EMA2/U1EMAN ENGINE — IGNITION COIL ASSY.

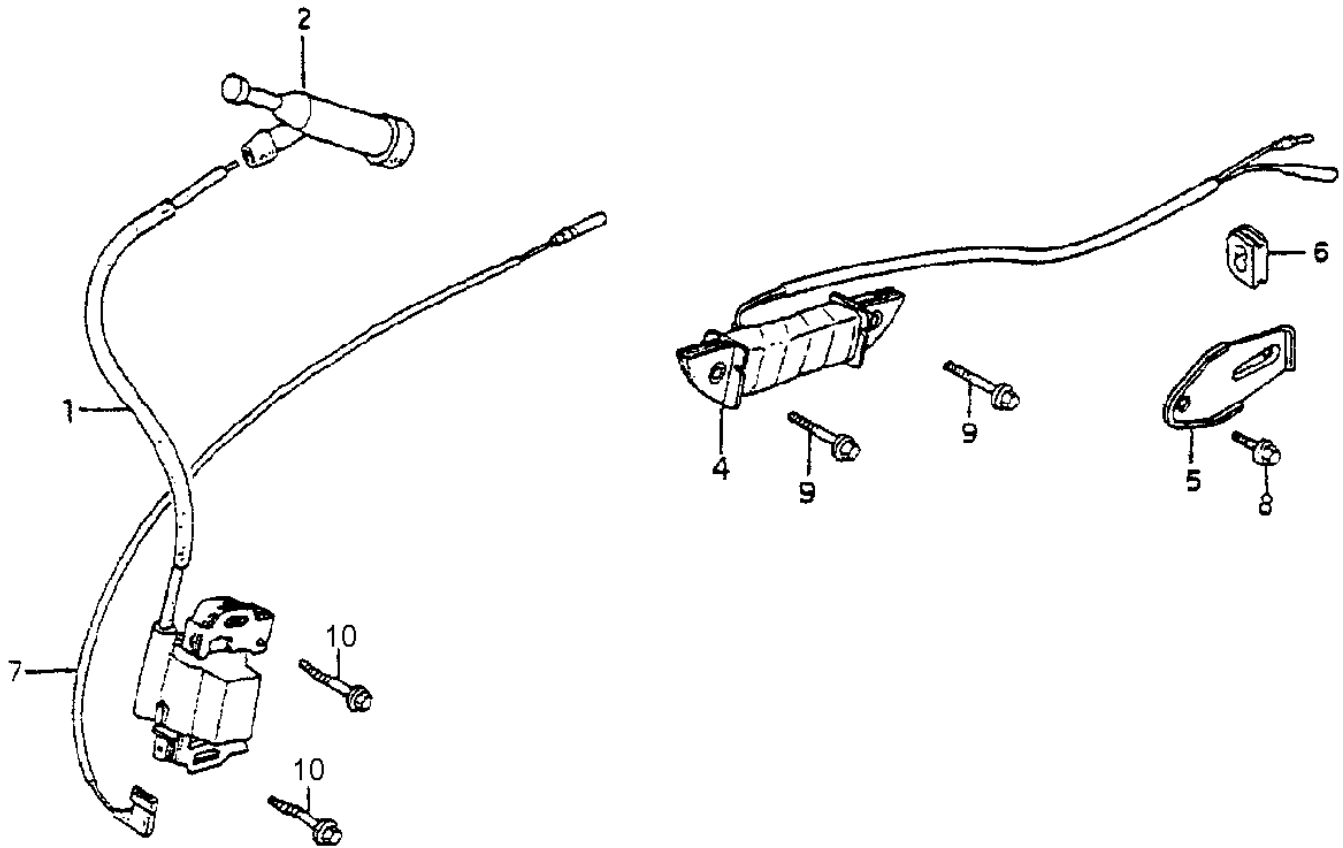

HONDA GX160K1EMA2/U1EMAN ENGINE — IGNITION COIL ASSY.

<u>NO.</u>	<u>PART NO.</u>	<u>PART NAME</u>	<u>QTY.</u>	<u>REMARKS</u>
1◆	30500ZE1033	COIL ASSY., IGNITION	1	
1◇	30500ZE1073	COIL ASSY., IGNITION	1	
2	30700ZE1013	CAP ASSY., NOISE SUPPRESSOR	1	
4	31510ZE1811	COIL ASSY., LAMP (12V25W)	1	
5	31511ZE1000	CLAMPER, CORD	1	
6	31511ZE1000	GROMMET, CORD	1	
7	36101ZE1010	CORD, STOP SWITCH (370 MM)	1	
8	90019883000	BOLT, FLANGE, 5X10	1	
9	90015883000	BOLT, FLANGE, 6X28	2	
10	90121952000	BOLT, FLANGE, 6X25	2	

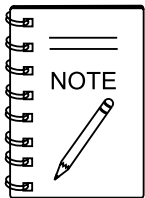

◆GX160K1EMA2: Model GAC2.2H, JUNE 2006 AND BELOW

◇GX160U1EMAN: Model GAC2.2H, FEBUARY 2007 AND ABOVE

HONDA GX160K1EMA2/U1EMAN ENGINE — GOV. CONTROL ASSY.

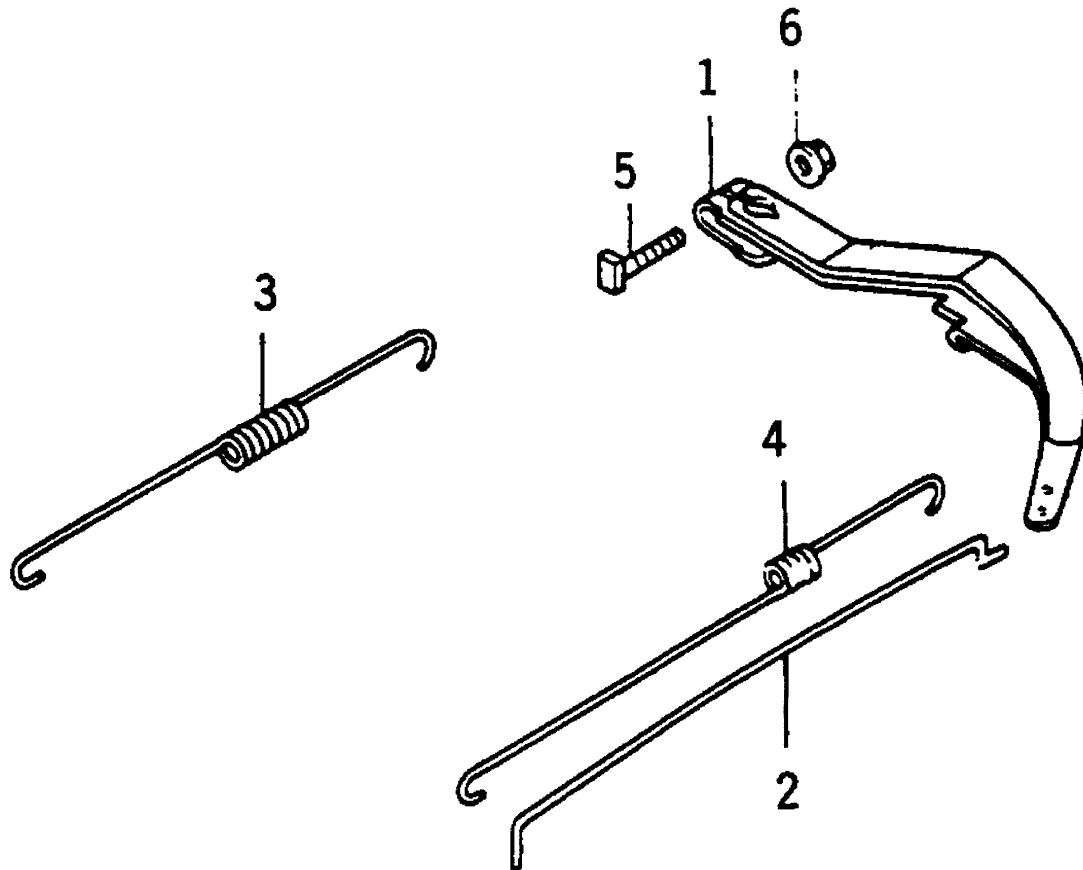

HONDA GX160K1EMA2/U1EMAN ENGINE — GOV. CONTROL ASSY.

NO.	PART NO.	PART NAME	QTY.	REMARKS
1◆	16551ZE0010	ARM, GOVERNOR	1.....	USE UP TO S/N 4913229
1◆	16551ZL0010	ARM, GOVERNOR	1.....	USE FROM S/N 4913230
1◇	16551ZL0000	ARM, GOVERNOR	1	
2	16555ZE1000	ROD, GOVERNOR	1	
3◆	16561ZH8D00	SPRING, GOVERNOR	1.....	USE UP TO S/N 4913229
3◆	16561ZL0U30	SPRING, GOVERNOR	1.....	USE FROM S/N 4913230-5048024
3◆	16561ZL0000	SPRING, GOVERNOR	1.....	USE FROM S/N 5048025
3◇	16561ZL0000	SPRING, GOVERNOR	1	
4	16562ZE1020	SPRING, THROTTLE RETURN	1	
5	90015ZE5010	BOLT, GOVERNOR ARM	1	
6	9405006000	NUT, FLANGE, 6MM	1	

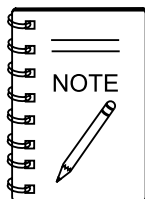

◆GX160K1EMA2: Model GAC2.2H, JUNE 2006 AND BELOW

◇GX160U1EMAN: Model GAC2.2H, FEBRUARY 2007 AND ABOVE

HONDA GX160K1EMA2/U1EMAN ENGINE — DECAL ASSY.

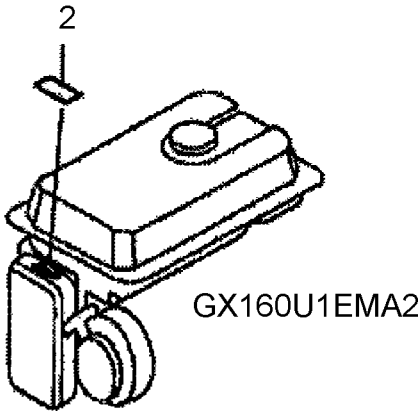
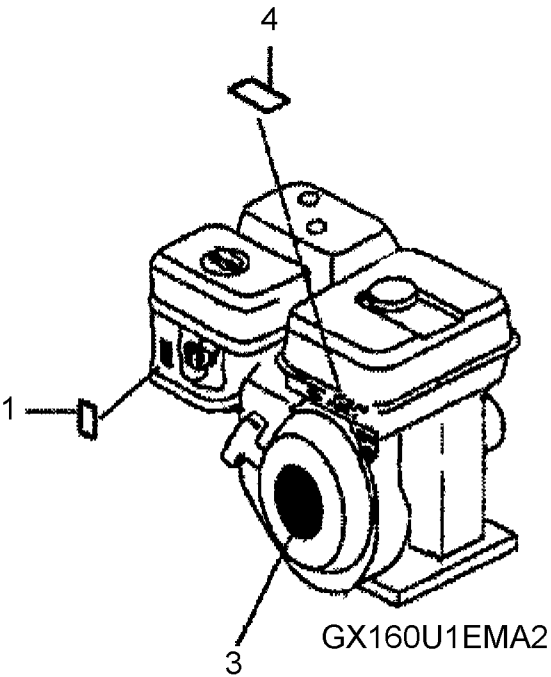
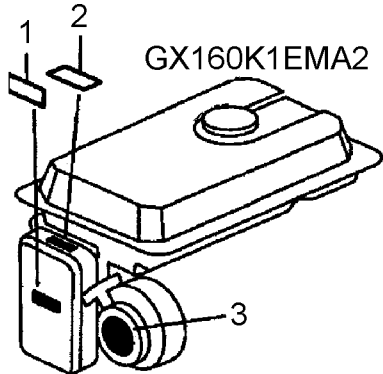

HONDA GX160K1EMA2/U1EMAN ENGINE — DECAL ASSY.

<u>NO.</u>	<u>PART NO.</u>	<u>PART NAME</u>	<u>QTY.</u>	<u>REMARKS</u>
1	87533ZC0630	DECAL, AIR CLEANER	1	
2	87528ZB2630	DECAL, CHOKE	1	
3◆	87521ZH8020	EMBLEM, 5.5 HP	1	
3◇	87521ZH8040	EMBLEM, 5.5 HP	1	
4◇	87516ZH7000	MARK OPERATOR CAUTION (ENGLISH).....1.....	1	USE UP TO S/N 1253961
4◇	87516ZH7010	MARK OPERATOR CAUTION (ENGLISH).....1.....	1	USE FROM S/N 1253962
4◇	87516ZH7010	MARK OPERATOR CAUTION (PICTOGRAPH) 1		

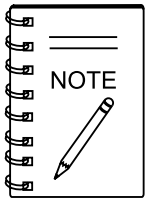

◆GX160K1EMA2: Model GAC2.2H, JUNE 2006 AND BELOW

◇GX160U1EMAN: Model GAC2.2H, FEBUARY 2007 AND ABOVE

HONDA GX160K1EMA2/U1EMAN ENGINE — TOOL KIT

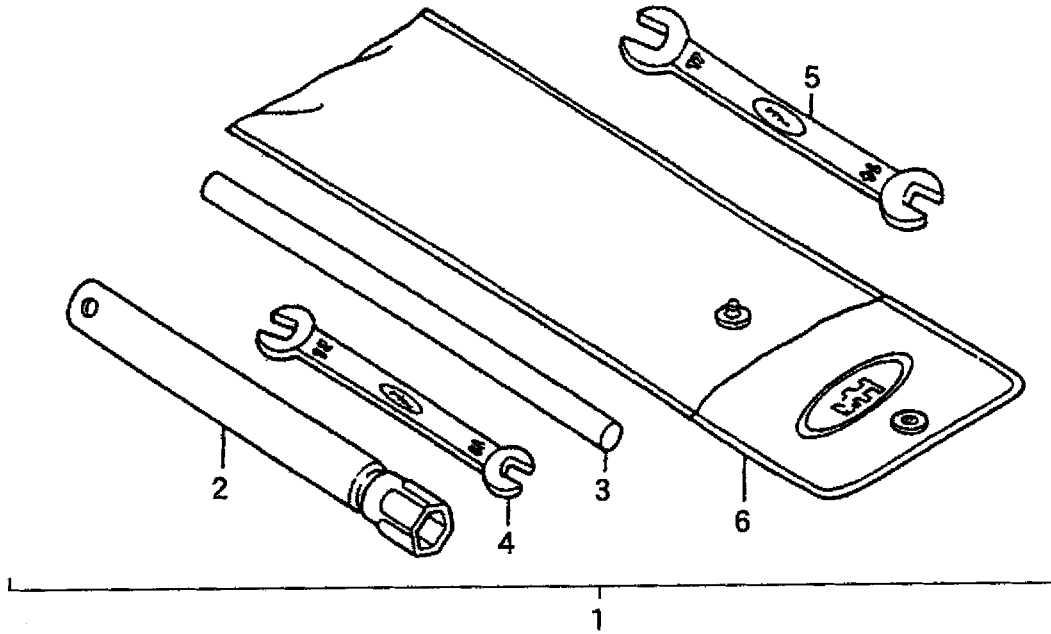

HONDA GX160K1EMA2/U1EMAN ENGINE — TOOL KIT

<u>NO.</u>	<u>PART NO.</u>	<u>PART NAME</u>	<u>QTY.</u>	<u>REMARKS</u>
1	89000ZE1000	TOOL KIT.....	1.....	INCLUDES ITEMS W/#
2#	89218ZE1000	WRENCH COMP. (SPARK PLUG)	1	
3#	89219805000	HANDLE, BOX WRENCH	1	
4#	9900110120	SAPNNER, 10X12	1	
5#	9900114170	SAPNNER, 14X17	1	
6#	9900802300	BAG TOOL	1	

TERMS AND CONDITIONS OF SALE — PARTS

PAYMENT TERMS

Terms of payment for parts are net 30 days.

FREIGHT POLICY

All parts orders will be shipped collect or prepaid with the charges added to the invoice. All shipments are F.O.B. point of origin. Multiquip's responsibility ceases when a signed manifest has been obtained from the carrier, and any claim for shortage or damage must be settled between the consignee and the carrier.

MINIMUM ORDER

The minimum charge for orders from Multiquip is \$15.00 net. Customers will be asked for instructions regarding handling of orders not meeting this requirement.

RETURNED GOODS POLICY

Return shipments will be accepted and credit will be allowed, subject to the following provisions:

1. A Returned Material Authorization must be approved by Multiquip prior to shipment.
2. To obtain a Return Material Authorization, a list must be provided to Multiquip Parts Sales that defines item numbers, quantities, and descriptions of the items to be returned.
 - a. The parts numbers and descriptions must match the current parts price list.
 - b. The list must be typed or computer generated.
 - c. The list must state the reason(s) for the return.
 - d. The list must reference the sales order(s) or invoice(s) under which the items were originally purchased.
 - e. The list must include the name and phone number of the person requesting the RMA.
3. A copy of the Return Material Authorization must accompany the return shipment.
4. Freight is at the sender's expense. All parts must be returned freight prepaid to Multiquip's designated receiving point.

5. Parts must be in new and resalable condition, in the original Multiquip package (if any), and with Multiquip part numbers clearly marked.
6. The following items are not returnable:
 - a. Obsolete parts. (If an item is in the price book and shows as being replaced by another item, it is obsolete.)
 - b. Any parts with a limited shelf life (such as gaskets, seals, "O" rings, and other rubber parts) that were purchased more than six months prior to the return date.
 - c. Any line item with an extended dealer net price of less than \$5.00.
 - d. Special order items.
 - e. Electrical components.
 - f. Paint, chemicals, and lubricants.
 - g. Decals and paper products.
 - h. Items purchased in kits.
7. The sender will be notified of any material received that is not acceptable.
8. Such material will be held for five working days from notification, pending instructions. If a reply is not received within five days, the material will be returned to the sender at his expense.
9. Credit on returned parts will be issued at dealer net price at time of the original purchase, less a 15% restocking charge.
10. In cases where an item is accepted, for which the original purchase document can not be determined, the price will be based on the list price that was effective twelve months prior to the RMA date.
11. Credit issued will be applied to future purchases only.

PRICING AND REBATES

Prices are subject to change without prior notice. Price changes are effective on a specific date and all orders received on or after that date will be billed at the revised price. Rebates for price declines and added charges for price increases will not be made for stock on hand at the time of any price change.

Multiquip reserves the right to quote and sell direct to Government agencies, and to Original Equipment Manufacturer accounts who use our products as integral parts of their own products.

SPECIAL EXPEDITING SERVICE

A \$35.00 surcharge will be added to the invoice for special handling including bus shipments, insured parcel post or in cases where Multiquip must personally deliver the parts to the carrier.

LIMITATIONS OF SELLER'S LIABILITY

Multiquip shall not be liable hereunder for damages in excess of the purchase price of the item with respect to which damages are claimed, and in no event shall Multiquip be liable for loss of profit or good will or for any other special, consequential or incidental damages.

LIMITATION OF WARRANTIES

No warranties, express or implied, are made in connection with the sale of parts or trade accessories nor as to any engine not manufactured by Multiquip. Such warranties made in connection with the sale of new, complete units are made exclusively by a statement of warranty packaged with such units, and Multiquip neither assumes nor authorizes any person to assume for it any other obligation or liability whatever in connection with the sale of its products. Apart from such written statement of warranty, there are no warranties, express, implied or statutory, which extend beyond the description of the products on the face hereof.

Effective: February 22, 2006

OPERATION AND PARTS MANUAL

HERE'S HOW TO GET HELP

PLEASE HAVE THE MODEL AND SERIAL
NUMBER ON-HAND WHEN CALLING

UNITED STATES

Multiquip Corporate Office

18910 Wilmington Ave. Tel. (800) 421-1244
Carson, CA 90746 Fax (800) 537-3927
Contact: mq@multiquip.com

Mayco Parts

800-306-2926 Fax: 800-672-7877
310-537-3700 Fax: 310-637-3284

Service Department

800-421-1244 Fax: 310-537-4259
310-537-3700

MQ Parts Department

800-427-1244 Fax: 800-672-7877
310-537-3700 Fax: 310-637-3284

Warranty Department

800-421-1244, Ext. 279 Fax: 310-537-1173
310-537-3700, Ext. 279

Technical Assistance

800-478-1244 Fax: 310-631-5032

MEXICO

MQ Cipsa

Carr. Fed. Mexico-Puebla KM 126.5 Tel: (52) 222-225-9900
Momoxpan, Cholula, Puebla 72760 Mexico Fax: (52) 222-285-0420
Contact: pmastretta@cipsa.com.mx

CANADA

Multiquip

4110 Industriel Boul. Tel: (450) 625-2244
Laval, Quebec, Canada H7L 6V3 Tel: (877) 963-4411
Contact: jmartin@multiquip.com Fax: (450) 625-8664

UNITED KINGDOM

Multiquip (UK) Limited Head Office

Unit 2, Northpoint Industrial Estate, Tel: 0161 339 2223
Global Lane, Fax: 0161 339 3226
Dukinfield, Cheshire SK16 4UJ
Contact: sales@multiquip.co.uk

© COPYRIGHT 2010, MULTIQUIP INC.

Multiquip Inc and the MQ logo are registered trademarks of Multiquip Inc. and may not be used, reproduced, or altered without written permission. All other trademarks are the property of their respective owners and used with permission.

This manual MUST accompany the equipment at all times. This manual is considered a permanent part of the equipment and should remain with the unit if resold.

The information and specifications included in this publication were in effect at the time of approval for printing. Illustrations, descriptions, references and technical data contained in this manual are for guidance only and may not be considered as binding. Multiquip Inc. reserves the right to discontinue or change specifications, design or the information published in this publication at any time without notice and without incurring any obligations.

Your Local Dealer is:



Free Manuals Download Website

<http://myh66.com>

<http://usermanuals.us>

<http://www.somanuals.com>

<http://www.4manuals.cc>

<http://www.manual-lib.com>

<http://www.404manual.com>

<http://www.luxmanual.com>

<http://aubethermostatmanual.com>

Golf course search by state

<http://golfingnear.com>

Email search by domain

<http://emailbydomain.com>

Auto manuals search

<http://auto.somanuals.com>

TV manuals search

<http://tv.somanuals.com>