

OPERATION AND PARTS MANUAL



MODEL GDP-5H **High Cycle Generator** **(HONDA GASOLINE ENGINE)**

Revision #2 (10/05/05)

**THIS MANUAL MUST ACCOMPANY
THE EQUIPMENT AT ALL TIMES.**

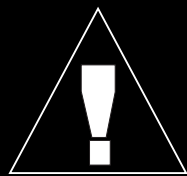

WARNING

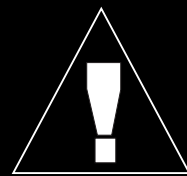

CALIFORNIA — Proposition 65 Warning

Engine exhaust and some of its constituents are known to the State of California to cause cancer, birth defects and other reproductive harm.

HERE'S HOW TO GET HELP

PLEASE HAVE THE MODEL AND SERIAL
NUMBER *ON-HAND* WHEN CALLING

MULTIQUIP CORPORATE OFFICE

18910 Wilmington Ave.

800-421-1244

Carson, CA 90746

FAX: 310-537-3927

Email: mq@multiquip.com

Internet: www.multiquip.com

PARTS DEPARTMENT

800-427-1244

FAX: 800-672-7877

310-537-3700

FAX: 310-637-3284

MAYCO PARTS

800-306-2926

FAX: 800-672-7877

310-537-3700

FAX: 310-637-3284

SERVICE DEPARTMENT

800-421-1244

FAX: 310-537-4259

310-537-3700

TECHNICAL ASSISTANCE

800-478-1244

FAX: 310-631-5032

WARRANTY DEPARTMENT

800-421-1244, EXT. 279

FAX: 310-537-1173

310-537-3700, EXT. 279

© COPYRIGHT 2004, MULTIQUIP INC.

Multiquip Inc, the MQ logo are registered trademarks of Multiquip Inc. and may not be used, reproduced, or altered without written permission. All other trademarks are the property of their respective owners and used with permission.

This manual **MUST** accompany the equipment at all times. This manual is considered a permanent part of the equipment and should remain with the unit if resold.

The information and specifications included in this publication were in effect at the time of approval for printing. Illustrations are based on the *MQ GDP-5H Portable Generator*. Illustrations, descriptions, references and technical data contained in this manual are for guidance only and may not be considered as binding. Multiquip Inc. reserves the right to discontinue or change specifications, design or the information published in this publication at any time without notice and without incurring any obligations.

To find the latest revision of this
publication, visit our website at:
www.multiquip.com



Multiquip GDP-5H — AC Portable Generator

Here's How To Get Help	3
Table Of Contents	4
Parts Ordering Procedures	5
Safety Message Alert Symbols	6-7
Rules for Safe Operation	8-10
Operation and Safety Decals	11
Specifications (Generator)	12
Specifications (Engine)	13
Dimensions	14
General Information	15
Load Application	16
Load Application/Earth Leakage Breaker	17
Controls and Indicators	18-20
Generator Refueling	21
Installation	22-23
Pre-Inspection	24
Pre-Inspection (Engine)	25
Initial Start-up (Engine)	26
Initial Start-up/Generator Operation	27-28
Shut-down/Long Term Storage	29
Maintenance (Engine).....	30-31
Wiring Diagram Gen. (S/N 5541049 & below)	32
Wiring Diagram Gen. (S/N 5543731 & above)	33
Troubleshooting (Engine)	34-35
Troubleshooting (Generator)	36
Explanation of Code In Remarks Column	38
Suggested Spare Parts	39

HONDA GX340K1EDN2 ENGINE

Air Cleaner Assembly	50-51
Camshaft Assembly	52-53
Carburetor Assembly	54-55
Control Assembly	56-57
Crankcase Cover Assembly	58-59
Crankshaft Assembly	60-61
Cylinder Barrel Assembly	62-63
Cylinder Head Assembly	64-65
Fan Cover Assembly	66-67
Flywheel Assembly	68-69
Ignition Coil Assembly	70-71
Piston Assembly	72-73
Recoil Starter Assembly	74-75
Solenoid Assembly	76-77
Label Assembly	78-79

Terms and Conditions Of Sale — Parts	80
--	----

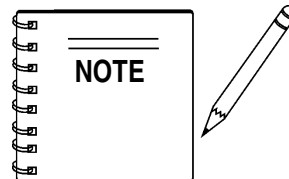

Specification and part number are subject to change without notice.

Component Drawings

Nameplate and Decals	40-41
Generator Assy.	42-43
Control Box Assy.	44-45
Muffler Assy.	46-47
Pipe Frame Assy.	48-49

PARTS ORDERING PROCEDURES

When ordering parts, please supply the following information:

- Dealer account number
- Dealer name and address
- Shipping address (if different than billing address)
- Return fax number
- Applicable model number
- Quantity, part number and description of each part
- Specify preferred method of shipment:
 - ✓ FedEx or UPS Ground
 - ✓ FedEx or UPS Second Day or Third Day
 - ✓ FedEx or UPS Next Day
 - ✓ Federal Express Priority One
 - ✓ DHL
 - ✓ Truck

Note: Unless otherwise indicated by customer, all orders are treated as "Standard Orders", and will ship within 24 hours. We will make every effort to ship "Air Shipments" the same day that the order is received, if prior to 2PM west coast time. "Stock Orders" must be so noted on fax or web forms.



Here's how to get help...

Please have the model and serial number on hand when calling.

MULTIQUIP CORPORATE OFFICE

18910 Wilmington Ave. 800-421-1244
 Carson, CA 90746 FAX: 310-537-3927
 Email: mq@multiquip.com
 Internet: www.multiquip.com

PARTS DEPARTMENT

800-427-1244 FAX: 800-672-7877
 310-537-3700 FAX: 310-637-3284

MAYCO PARTS

800-306-2926 FAX: 800-672-7877
 310-537-3700 FAX: 310-637-3284

SERVICE DEPARTMENT

800-421-1244 FAX: 310-537-4259
 310-537-3700

TECHNICAL ASSISTANCE

800-478-1244 FAX: 310-631-5032

WARRANTY DEPARTMENT

800-421-1244, EXT. 279 FAX: 310-537-1173
 310-537-3700, EXT. 279

Place Your Parts Order Via Web or Fax For Even More Savings!

(Domestic USA Dealers Only)

Extra Discounts!

All parts orders which include complete part numbers and are received by our automated web parts order system, or by fax qualify for the following extra discounts:

Ordered via	Standard orders	Stock orders (\$750 list and above)
Fax	3%	10%
Web	5%	10%

Special freight allowances when you order 10 or more line items via Web or Fax! **

FedEx Ground Service *at no charge for freight*

No other allowances on freight shipped by any other carrier.

***Common nuts, bolts and washers (all items under \$1.00 list price) do not count towards the 10+ line items.*

NOTE: DISCOUNTS ARE SUBJECT TO CHANGE



MULTIQUIP INC.
 18910 WILMINGTON AVENUE
 POST OFFICE BOX 6254
 CARSON, CALIFORNIA 90749
 310-537-3700 • 800-421-1244
 FAX: 310-537-3927
 E-MAIL: mq@multiquip.com
 INTERNET: www.multiquip.com

Direct TOLL-FREE access to our Parts Department:

Toll-free nationwide — 800-427-1244
 Toll-free FAX — 800-6-PARTS-7 (800/672-7877)

GDP-5H — SAFETY MESSAGE ALERT SYMBOLS

FOR YOUR SAFETY AND THE SAFETY OF OTHERS!

Safety precautions should be followed at all times when operating this equipment. Failure to read and understand the Safety Messages and Operating Instructions could result in injury to yourself and others.

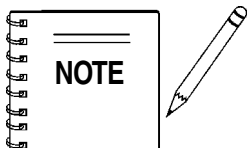

This Owner's Manual has been developed to provide complete instructions for the safe and efficient operation of the **MQ Model GDP-5H Portable Generator**. Refer to the engine manufacturers instructions for data relative to its safe operation.

Before using this generator, ensure that the operating individual has read and understands all instructions in this manual.

SAFETY MESSAGE ALERT SYMBOLS

The three (3) Safety Messages shown below will inform you about potential hazards that could injure you or others. The Safety Messages specifically address the level of exposure to the operator, and are preceded by one of three words: **DANGER**,

DANGER

You **WILL** be **KILLED** or **SERIOUSLY INJURED** if you **DO NOT** follow these directions.

WARNING

You **CAN** be **KILLED** or **SERIOUSLY INJURED** if you **DO NOT** follow these directions.

CAUTION

You **CAN** be **INJURED** if you **DO NOT** follow these directions.

HAZARD SYMBOLS

Potential hazards associated with the operation of a **GDP-5H Portable Generator** will be referenced with Hazard Symbols which appear throughout this manual, and will be referenced in conjunction with Safety Message Alert Symbols.

WARNING Lethal Exhaust Gas Hazards

Engine exhaust gases contain poisonous carbon monoxide. This gas is colorless and odorless, and can cause death if inhaled. **NEVER** operate this equipment in a confined area or enclosed structure that does not provide ample free flow air.



WARNING Explosive Fuel Hazards

Gasoline is extremely flammable, and its vapors can cause an explosion if ignited. **DO NOT** start the engine near spilled fuel or combustible fluids.



DO NOT fill the fuel tank while the engine is running or hot. **DO NOT** overfill tank, since spilled fuel could ignite if it comes into contact with hot engine parts or sparks from the ignition system. Store fuel in approved containers, in well-ventilated areas and away from sparks and flames.

WARNING Burn Hazards

Engine components can generate extreme heat. To prevent burns, **DO NOT** touch these areas while the engine is running or immediately after operations. Never operate the engine with heat shields or heat guards removed.



WARNING Respiratory Hazards

ALWAYS wear approved **respiratory** protection when required.



GDP-5H — SAFETY MESSAGE ALERT SYMBOLS

CAUTION

Rotating Parts Hazards

NEVER operate equipment with covers, or guards removed. Keep fingers, hands, hair and clothing away from all moving parts to prevent injury.



CAUTION

Equipment Damage Hazards

Other important messages are provided throughout this manual to help prevent damage to your portable generator, other property, or the surrounding environment.

CAUTION

Accidental Starting Hazards

ALWAYS place the power source, circuit breakers or **ON/OFF** switch in the **OFF** position, when the generator is not in use, unless connected to transfer switch.



CAUTION

Eye and Hearing Hazards

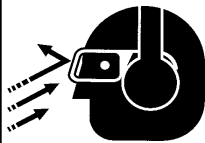

ALWAYS wear approved eye and hearing protection.

GDP-5H — RULES FOR SAFE OPERATION

DANGER

Read this manual!

Failure to follow instructions in this manual may lead to serious injury or even death! This equipment is to be operated by trained and qualified personnel only! This equipment is for industrial use only.

The following safety guidelines should always be used when operating the GDP-5H Portable Generator:

GENERAL SAFETY

■ **DO NOT** operate or service this equipment before reading this entire manual.



■ This equipment should not be operated by persons under 18 years of age.

■ **NEVER** operate this equipment without proper protective clothing, shatterproof glasses, steel-toed boots and other protective devices required by the job.



■ **NEVER** operate this equipment when not feeling well due to fatigue, illness or taking medicine.



■ **NEVER** operate this equipment under the influence of **drugs** or **alcohol**.



■ **ALWAYS** wear proper respiratory (mask), hearing and eye protection equipment when operating the generator.



■ Whenever necessary, replace nameplate, operation and safety decals when they become difficult read.

■ Manufacturer does not assume responsibility for any accident due to equipment modifications.

■ **NEVER** use accessories or attachments, which are not recommended by Multiquip for this equipment. Damage to the equipment and/or injury to user may result.

■ **NEVER** touch the hot exhaust manifold, muffler or cylinder. Allow these parts to cool before servicing engine or generator.

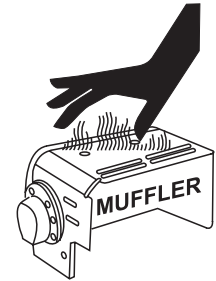

■ The engine section of this generator requires an adequate free flow of cooling air. **NEVER** operate the generator in any enclosed or narrow area where free flow of the air is restricted. If the air flow is restricted it will cause serious damage to the generator or engine and may cause injury to people. Remember the generator's engine gives off **DEADLY** carbon monoxide gas.

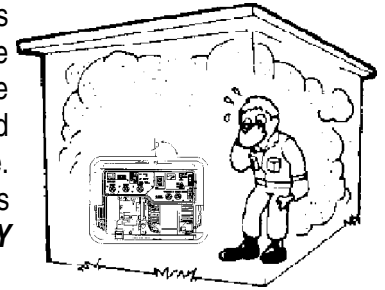

■ **ALWAYS** refuel in a well-ventilated area, away from sparks and open flames.

■ **ALWAYS** use extreme caution when working with **flammable** liquids. When refueling, **stop the engine** and allow it to cool. **DO NOT smoke** around or near the machine. Fire or explosion could result from fuel vapors, or if fuel is spilled on a hot engine.



■ **NEVER** operate the generator in an explosive atmosphere or near combustible materials. An explosion or fire could result causing severe **bodily harm or even death**.

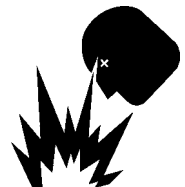

■ **NEVER** disconnect any "**emergency or safety devices**". These devices are intended for operator safety. Disconnection of these devices can cause severe injury, bodily harm or even death! Disconnection of any of these devices will void all warranties.

GDP-5H — RULES FOR SAFE OPERATION

- **ALWAYS** be sure the operator is familiar with proper safety precautions and operation techniques before using generator.
- **NEVER** leave the generator unattended, turn off engine when unattended.
- Unauthorized equipment modifications will void all warranties.
- **ALWAYS** ensure generator is on level ground before use.
- **DO NOT** place hands or fingers inside generator engine compartment when engine is running.
- **NEVER** run engine without air cleaner. Severe engine damage may occur.
- **NEVER** change or adjust the engine speed which has been set at the factory prior to shipping.



Power Cord Safety

- **NEVER** let power cables or cords *lay in water*.
- **NEVER** *stand in water* while AC power from the generator is being transfer to a load.
- **NEVER** use a defective or frayed power cable. Check the cable for cuts in the insulation.
- **NEVER** use a extension cord that is frayed or damaged where the insulation has been cut.
- **ALWAYS** make certain that proper power or extension cord has been selected for the job See Tables 4 and 5.

Grounding Safety

- **ALWAYS** make sure that electrical circuits are properly *grounded* per the **National Electrical Code** (NEC) and local codes before operating generator. Severe *injury* or *death!* by electrocution can result from operating an ungrounded generator.
- **ALWAYS** make sure generator is properly grounded to a suitable earth ground (**GROUND ROD**). See installation section in this manual.
- **NEVER** use *gas piping* as an electrical ground.

Maintenance Safety

- **NEVER** lubricate components or attempt service on a running machine.
- **High Temperatures** – Always stop engine and allow the engine to cool before adding fuel, oil or performing service and maintenance functions. Contact with **hot!** components can cause serious burns. 
- Keep the machinery in proper running condition.
- Fix damage to the machine immediately and replace any broken parts immediately.
- **ALWAYS** replace any worn or damaged warning decals.
- **ALWAYS** store equipment properly when it is not being used. Equipment should be stored in a clean, dry location out of the reach of children and un-authorized personnel.
- The electrical voltage required to operate the generator can cause severe injury or even death through physical contact with live circuits. Turn all circuit breakers **OFF** before performing maintenance on the generator.
- Dispose of hazardous waste properly. Examples of potentially hazardous waste are used motor oil, fuel and fuel filters.
- **DO NOT** use food or plastic containers to dispose of hazardous waste.
- **DO NOT** pour waste, oil or fuel directly onto the ground, down a drain or into any water source.
- Removing the engine oil drain plug while the engine is hot will result in hot oil to gush out of the oil drain plug, therefore causing severe scalding to any persons in the general area of the generator. 

DANGER-ELECTROCUTION HAZARDS

During operation of this generation, there exists the possibility of **electrocution, electrical shock or burn**, which can cause **severe bodily harm** or even **DEATH!**



To avoid these hazards:

NEVER use **damaged** or **worn** cables when connecting equipment to the generator. Make sure power connecting cables are securely connected to the generator's output receptacles, incorrect connections may cause damage to the generator and electrical shock.

NEVER grab or touch a live power cord with wet hands, the possibility exist of electrical shock, electrocution, and even **death!**

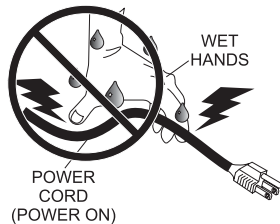

NEVER insert any objects into the output receptacles during operation. This is extremely dangerous. **ALWAYS** turn-off the generator and place all circuit breakers in the "OFF" position when contact with the output receptacles is required. There exist the possibility of **electrocution, electrical shock or burn, which can cause severe bodily harm or even death!**

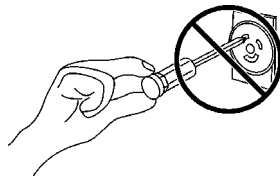

Backfeed to a utility system can cause **electrocution** and or property damage. **NEVER** connect the generator to a building's electrical system without a transfer switch or other approved device. All installations should be performed by a **licensed electrician** in accordance with all applicable laws and electrical codes. Failure to do so could result in electrical shock or burn causing serious injury or even death!

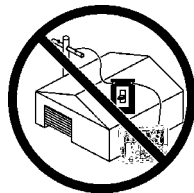

Emergencies

■ **ALWAYS** know the location of the nearest **fire extinguisher**.

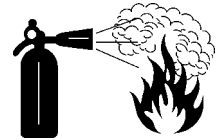

■ **ALWAYS** know the location of the nearest **first aid kit**.



■ In emergencies **always** know the location of the nearest phone or **keep a phone on the job site**. Also know the phone numbers of the nearest **ambulance, doctor** and **fire department**. This information will be invaluable in the case of an emergency.

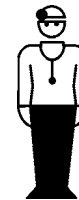

GDP-5H — OPERATION AND SAFETY DECALS

Machine Safety Decals

The GDP-5H portable generator is equipped with a number of safety decals (Figure 1). These decals are provided for operator safety and maintenance information. The illustration below shows these decals as they appear on the machine. Should any of these decals become unreadable, replacements can be obtained from your dealer.

MQ MULTIQUIP 5000

P/N A4561000103



P/N 8700611804



P/N 1980680004



**CONTACT
MQ PARTS DEPT.**



P/N 8700611904

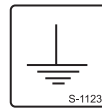

P/N 0800628504

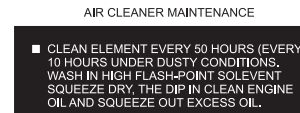

P/N 060050045

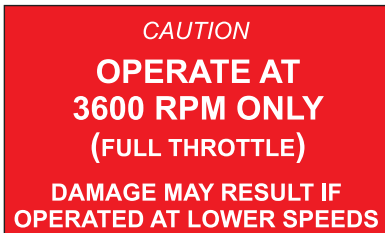

P/N 7900636004

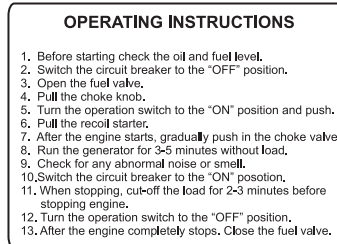

P/N A9521200104



P/N 35137

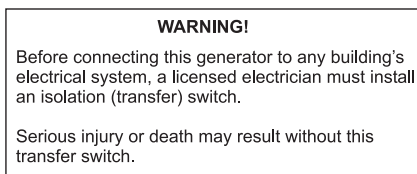

P/N 0820610404

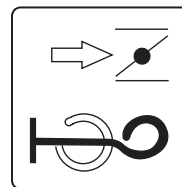

P/N 0600500047

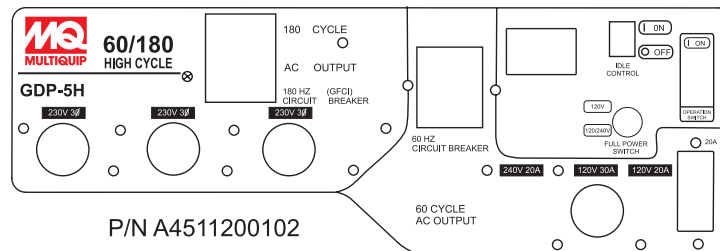

Figure 1. Operation and Safety Decals

GDP-5H — SPECIFICATIONS (GENERATOR)

Table 1. Specifications (Generator)

AC Generator	Model	GDP-5H
	Type	Brushless Revolving Field Type
	Excitation	Solid State, Statically Excited System
	Speed	3,600 RPM
	Cooling System	Self-Ventilation
	Fuel Capacity	5 gallons (19 liters)
60 Cycle AC Power Source	Continuous Output	3.6 kW
	Standby Output	4.0 kW
	Rated Voltage	120/240 V
	Rated Current	30 amps (120V)
	Rated Current	15 amps (240V)
	Phase	Single Phase (4 wire)
	Frequency	60 Hz
	Power Factor	1
180 Cycle AC Power Source	Continuous Output	5 kVA
	Rated Voltage	230 V
	Rated Current	12.5 A
	Phase	Three Phase (4 wire)
	Frequency	180 Hz
	Power Factor	80% (Lag)
Dimensions (L x W x H)		28.34 x 22.04 X 21.25 in. (720 X 560 X 540 mm)
Dry Net Weight		235 lbs. (107 kg.)
Weight (With Fuel)		269 lbs. (122 kg.)

Effects of Altitude and Heat

The maximum output of the engine listed above is applicable to supplying electrical power for continuous service at ambient conditions in accordance with SAE Test cord J607. The above ambient conditions are at standard sea level, with a barometric reading of 29.92 inches and a temperature of 60 degrees fahrenheit.

Generally, the engine output power will decrease 3-1/2% for each 1000 feet of altitude above sea level, and 1% for each 10° F Fahrenheit above the standard temperature of 60° F

Table 2. Specifications (Engine)

Table 2. Specifications (Engine)		
Engine	Model	HONDA GX340K1EDN2
	Type	Air-cooled 4 stroke, Single Cylinder, OHV, Horizontal Shaft Gasoline Engine
	Bore X Stroke	2.90 in. X 2.30 in. (73 mm x 58 mm.)
	Displacement	23.70 cu-in (389 cm ³)
	Max Output	11.0 H.P./3600 R.P.M.
	Fuel	Unleaded Automobile Gasoline
	Lube Oil Capacity	1.16 quarts (1.1 liters)
	Oil Alert System	Yes
	Speed Control Method	Centrifugal Fly-weight Type
	Starting Method	Recoil Start
Dimension (L x W x H)		15.0 x 17.7 X 17.4 in. (380 X 450 X 443 mm.)
Dry Net Weight		68.4 lbs (31 Kg.)

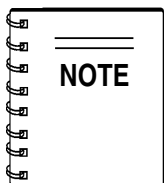

In keeping with Multiquip's policy of constantly improving its products, the specifications quoted herein are subject to change without prior notice.

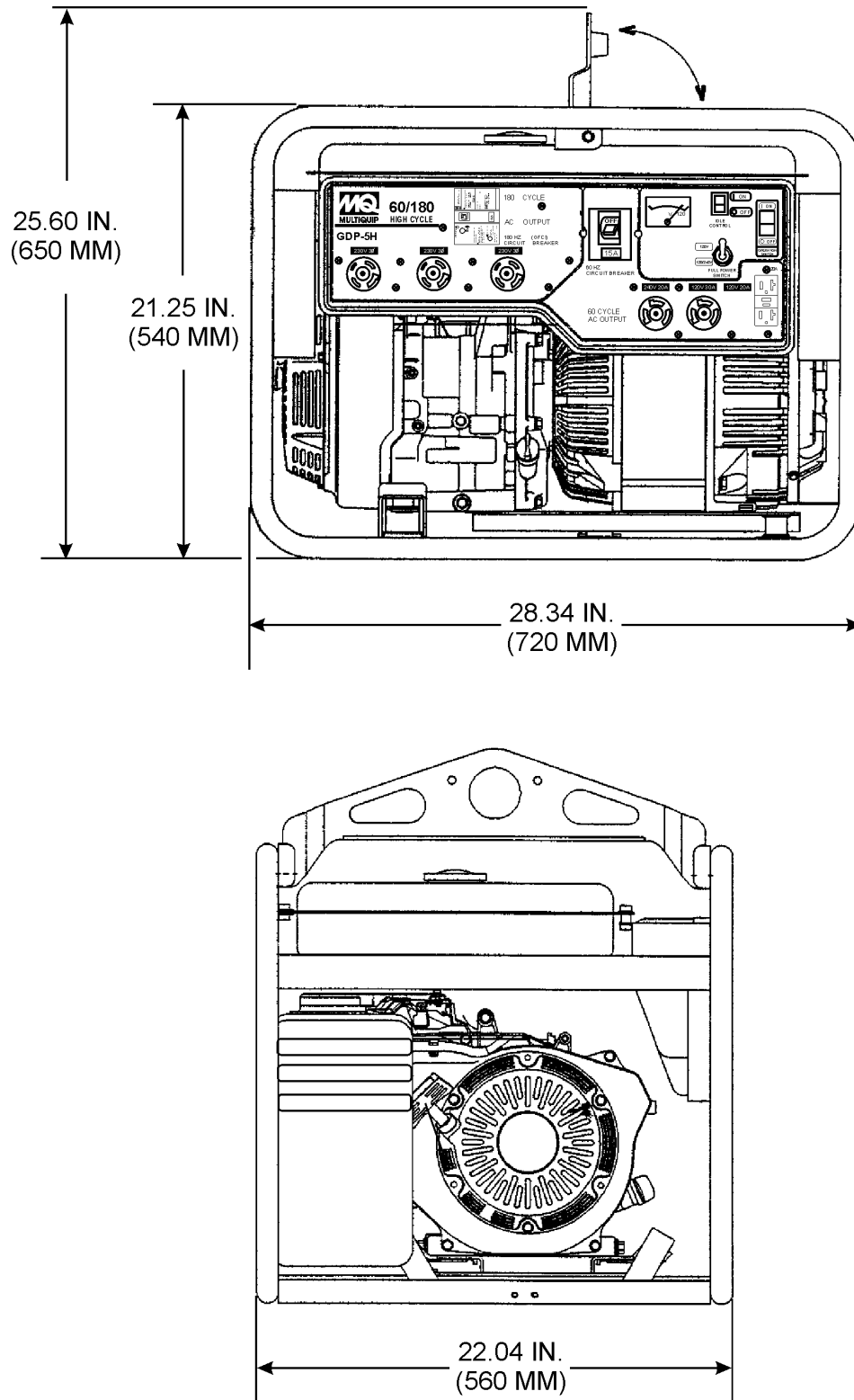

Figure 2. Dimensions

WARNING

Before connecting this generator to any building's electrical system, a licensed electrician must install an isolation (transfer) switch.

Serious injury or death may result without this transfer switch.

GDP-5H FAMILIARIZATION

Generator

The Multiquip Model GDP-5H generator has been designed as a portable dual purpose power source for 60 Hz (single phase) lighting facilities, power tools, submersible pumps and other industrial and construction machinery. In addition the Model GDP-5H has been designed as a power source for 180 Hz, 3-phase concrete vibrators or other equipment that may require 3-phase power for operation.

The generator is mounted on rubber vibration isolators that have a steel base backplate which is attached to the protective steel pipe carrying frame. The protective carrying frame is made of steel tubing and fully wraps around the generator to protect against damage. See Figures 4A through 4E for the basic controls and indicators for the GDP-5H generator.

This portable generator is supplied with a electrical **control box**. To reduce vibration caused by the engine, the control box is also placed on rubber isolators.

Control Box

The control box is provided with the following:

- Three 230V twist-lock output receptacles (three phase).
- 240V twist-lock output receptacle (single phase).
- 120V twist-lock receptacle (single phase).
- 120V GFCI duplex output receptacle, (single phase).
- 60 Hz (single phase) circuit breaker.
- 180 Hz (three phase) earth leakage circuit breaker.
- AC Voltmeter
- Ground Terminal
- Full Power Switch
- Idle Control Switch
- Operation Switch

Excitation System

The GDP-5H-series generators use a magnet attached to a flywheel to produce AC voltage from a lamp coil beneath the flywheel. As the magnetic passes the coil it produces approximately 19-22 AC volts.

This voltage (19-22 VAC) is then sent to the control box that contains three rectifying diodes:

- Excitation (diode 1)
- Battery (diode 2)
- Slow Down (diode 3)

The AC voltage will pass through the excitation diode that converts the voltage to DC power.

This DC power is then sent to the excitation windings housed within the main windings commonly called the "stator".

This voltage is then transferred into the rotor through induction. The rotor contains two diodes within it which rectify the DC voltage and send it out through the main windings, as AC voltage.

Alternator

The alternator, a brushless revolving-field type, is permanently aligned to the engine through rigid coupling.

Engine

This generator is powered by a 11 HP, air-cooled, 4-stroke **HONDA** gasoline engine. Reference Table 2, for engine specifications.

3-Phase Vibrator Application

When using this generator with 3-phase vibrators do the following:

- **ALWAYS** use a vibrator with short circuit protection.
- **ALWAYS** use rubber boots and gloves when operating the vibrator.
- **ALWAYS** use adequate size connecting cable for extension.
- **ALWAYS** maintain electrical cords in good condition and frequently replace the entire cable of the vibrator with a new one.

Single Phase Load — 60 Hz

Always be sure to check the nameplate on the generator and equipment to insure the wattage, amperage and frequency requirements are satisfactorily supplied by the generator for operating the equipment.

Generally, the wattage listed on the nameplate of the equipment is its rated output. Equipment may require 130—150% more wattage than the rating on the nameplate, as the wattage is influenced by the efficiency, power factor and starting system of the equipment.

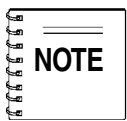

If wattage is not given on the equipment's name plate, approximate wattage may be determined by multiplying nameplate voltage by the nameplate amperage.

WATTS = VOLTAGE x AMPERAGE

The power factor of this generator is 1.0 See Table 3 below when connecting loads.

Table 3. Power Factor By Load

Type Of Load	Power Factor
Single-phase induction motors	0.4 - 0.75
Electric heaters, incandescent lamps	1.0
Fluorescent lamps, mercury lamps	0.4 - 0.9
Electronic devices, communication equipment	1.0
Common power tools	0.8

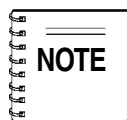

When using a combination of dual receptacles, total load **should not exceed** the rated capacity of the generator.

To determine the running wattage for your load, multiply the running wattage as indicated by steps 1, 2, and 3 below:

1. INCANDESCENT LOADS

Lights, heaters and similar appliances.

Total the running wattage and multiply by 1.

Example:

29 light bulbs @ 100W each = 2.9 KW

use a 3 KW generator.

2. SMALL MOTORS

Drills and other small power tools.

Total the running wattage and multiply by 2.

Example:

A 1 inch drill runs at 1 KW

use a 2 KW generator.

3. LARGE MOTORS

Submersible pumps, table saws etc.

Total the running wattage and multiply by 3.

Example:

A conveyor belt runs at 8 KW

use a 24 KW generator.

CAUTION

Motors and motor-driven equipment draw much greater current for starting than during operation. **Always** use an adequate size **extension cable** which can carry the required load.

Extension Cables

When electric power is to be provided to various tools or loads at some **distance** from the generator, extension cords are normally used. **Cables should be sized to allow for distance in length and amperage so that the voltage drop between the generator and point of use (load) is held to a minimum.** Use the cable selection chart (Tables 4 and 5) as a guide for selecting proper cable size.

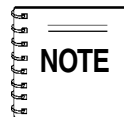

The idle control device is operated at a minimum load capacity of 100W. If the load capacity is less than 100W, place the idle control switch in the **OFF** position.

GDP-5H — LOAD APPLICATION/EARTH LEAKAGE BREAKER

Three Phase Load — 180 Hz

180 Hz, three phase, 230V, motor-in-head vibrators can be operated with this generator. When operating more than one concrete vibrator, the ON/OFF switch of each concrete vibrators shall be turned on one at a time.

If they are switched on simultaneously, the circuit breaker may trip or the engine may be overloaded.

The vibrators can be operated simultaneously if the total power consumption does not exceed the rated output of the generator (5.0 KVA).

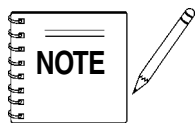

If output (kVA) is not given on the vibrators nameplate, approximate output may be determined by multiplying voltage by amperage by $\sqrt{3}$.

$$\text{KVA} = \frac{\text{VOLTAGE} \times \text{AMPERAGE} \times \sqrt{3}}{1000}$$

Earth Leakage Breaker (180 Hz)

The earth leakage detection breaker (Figure 3) is used for 180 Hz application (3-phase vibrators). Before operating the generator test this breaker to make sure that is functioning correctly.

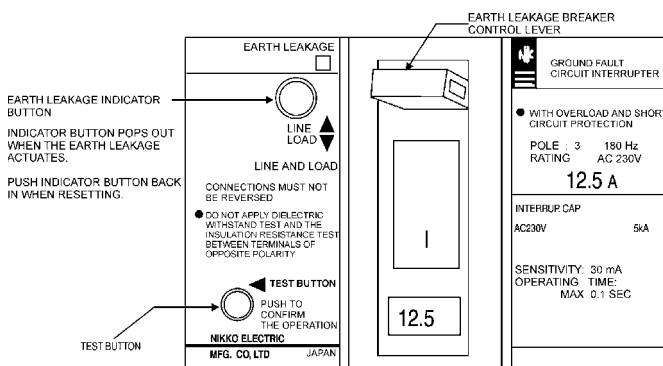

Figure 3. Earth Leakage Breaker



Before operating generator press earth leakage test button. The earth leakage breaker's earth leakage detection sensitivity is 30 mA, and the actuation time is 0.1 sec.

How to Use

Always conduct the following in order that the earth leakage breaker will operate safely. Also, if the leakage breaker should for some reason actuate, first stop the generator and then repair or eliminate the source of the earth leakage before resetting the leakage breaker. When setting up the generator perform the following:

Ground the Generator

Ground the generator from its ground connector so that resistance to ground is 500 ohms or less.

Ground the Tool

Ground the tool (load) in the same manner as the generator.



Simply because the generator is equipped with a earth leakage breaker does not mean that grounding of the load can be neglected, please be sure to properly ground load equipment.

Test Operation

For safety's sake, the operation of the earth leakage breaker should be tested periodically according to the following procedure:

1. Start the engine and set it to **high speed**.
2. Turn the leakage breaker **ON**.
3. During normal operation, press the earth leakage indicator test button on the front of the generator and observe that indicator button pops out and the leakage breaker trips.
4. Push the indicator button back in when resetting.

GDP-5H — CONTROLS AND INDICATORS

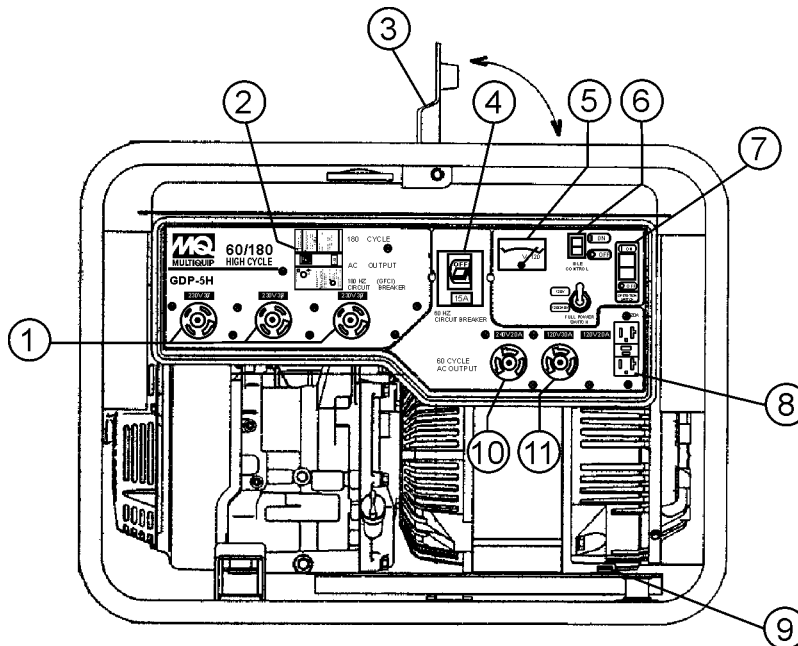

Figure 4A. Generator Components

1. **230V Output Receptacles**— These three NEMA 7410 twist-lock receptacles will provide 230V, 12.5 amps, 180 Hz.
2. **180 Hz Earth Leakage Circuit Breaker** – This 3-pole earth leakage circuit breaker allows the circuit to be broken when the load side shorts or there is an over-current condition. In addition, during operation of the generator it can detect when there is defective insulation on the load side and breaks the circuit in response. When starting the generator *always* have the circuit breaker placed in the "OFF" position.
3. **Lifting Bail Eye** – Attach a rope or chain to this lifting eye when lifting of the generator is required. Never stand underneath the generator while it is being lifted. Place lifting eye in down position when not in use.
4. **60 Hz Circuit Breaker** – This 2-pole circuit breaker (240/15 amps or 120/30 amps) protects the generator from short circuiting or overloading. When starting the generator *always* have the circuit breaker placed in the "OFF" position.
5. **AC-Voltmeter** – This voltmeter indicates (with a mark) the rated 60 Hz (single-phase) output voltage. In addition the voltmeter can also be used as a diagnostic tool. If the voltmeter indicator (needle) is below the rated voltage, engine problems may exist (low/high RPM's). To prevent damage to the generator or power tools turn the generator **OFF** and consult your authorized Multiquip service dealer. This meter cannot be used for 180 Hz applications.
6. **Idle Control Switch** – This generator is provided with an automatic idle control device for noise suppression and reduced fuel consumption. The automatic idle control automatically engages under a no-load condition. With the automatic idle control switched "ON", the engine revolutions will automatically drop to about 2600 rpm (low-speed operation) within 3 seconds after the load stops. When the operation is resumed, the engine speed is automatically increased to about 3600 rpm (high-speed operation) as soon as the load is connected.
7. **Operation Switch** – Place this *rocker* switch in the "ON" position (up) for normal operation. To turn-off the generator place this switch in the "OFF" position (down).
8. **GFCI Duplex Receptacle** – This NEMA 5-20R, GFCI receptacle will provide 120V, 20 amps.
9. **Ground** – This ground connection point should be connect to a good earth ground (ground rod).
10. **240V Output Receptacle** – This NEMA L6-20R twist-lock receptacle will provide 240V, 15 amps, 60 Hz.
11. **120V Output Receptacle** – This NEMA L5-30R twist-lock receptacle will provide 120V, 30 amps, 60 Hz.

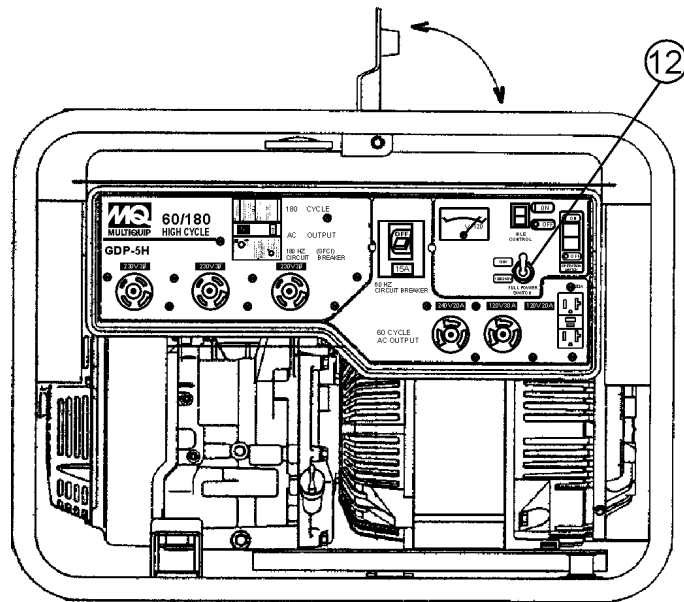

Figure 4B. Generator Components

12. **Full Power Switch** – The generator is provided with a full power switch. Figures 4C and 4D show simplified wiring diagrams of the dual voltage system.

When the full power switch is in the 120 volt (up) position, you can access the **full rated power** of the generator at 120 volts from the GFCI duplex receptacle and the 120V twist-lock receptacle, or a combination of both receptacles as long as the total load does not exceed the generating set capacity.

When the switch is in the 240 volt (down) position, you can access **half of the rated power** of the generating set at 120 volts from the GFCI duplex receptacle and up to half of the rated power of the set at 120 volts from 120V twist-lock receptacle; or full rated power of the set at 240 volts from the 240V twist-lock receptacle.

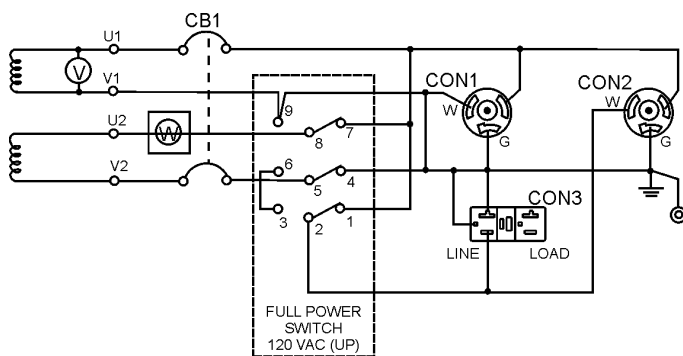

Figure 4C. 120V Full Power Switch Simplified Diagram (Up Position)

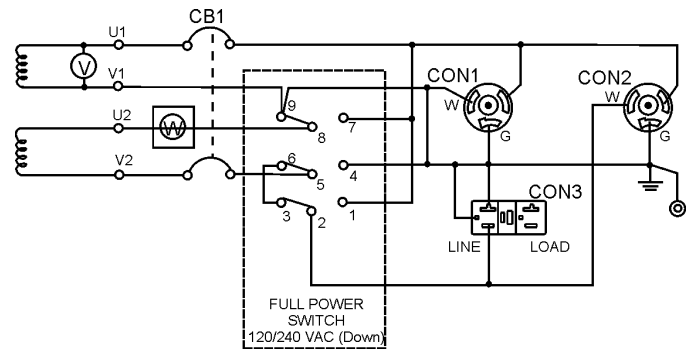

Figure 4D. 120/240V Full Power Switch Simplified Diagram (Down Position)



When the **full power switch** is in the 120V position, the 240V twist-lock receptacle **cannot be used**.

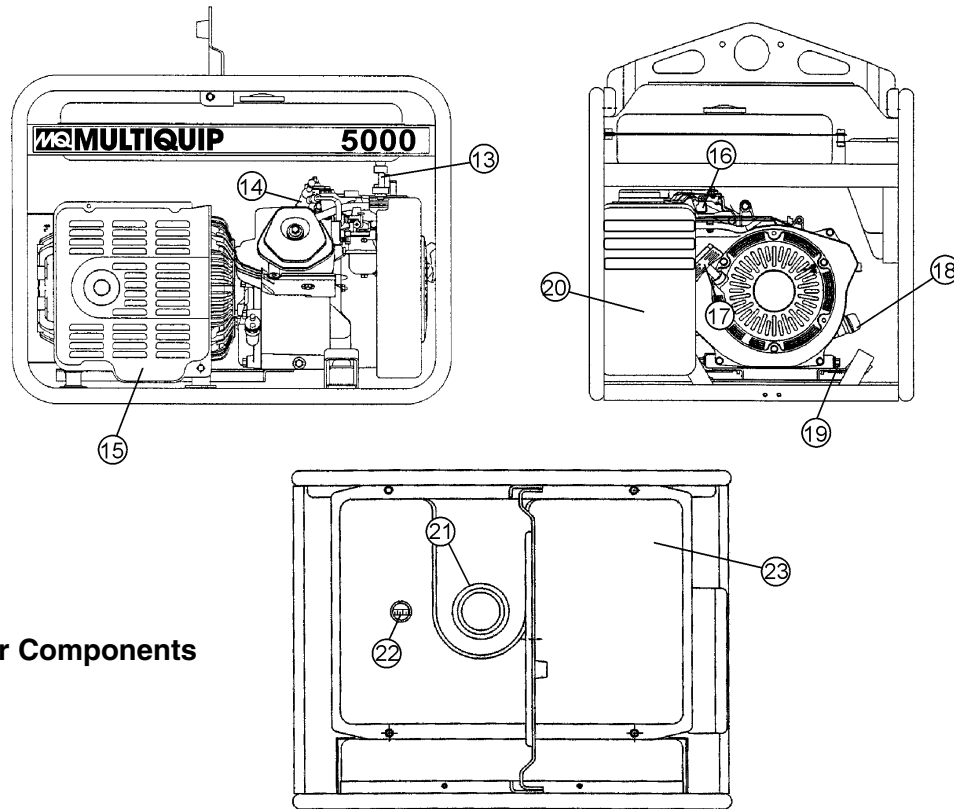
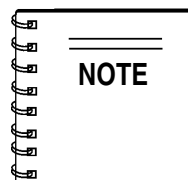

Figure 4E. Generator Components

13. **Fuel Cock Lever** – Turn this lever **downward** to **start** (down) the flow of fuel into the carburetor. Turn **upward** to **stop** (up) the flow of fuel.
14. **Spark Plug** – Provides spark to the ignition system. Set spark plug gap to 0.6 - 0.7 mm (0.028 - 0.031 inch) Clean spark plug once a week.
15. **Muffler/Heat Shield** – Used to reduce noise and emissions. **NEVER** touch this **heat shield** when the generator/welder is in use. Always allow time for the generator to cool down before performing maintenance.
16. **Choke Lever** – Used for starting the engine. **Close** the choke lever when starting a cold engine or in cold weather conditions. The choke enriches the fuel mixture. **Open** the choke lever if starting a warm engine or in warm weather conditions.
17. **Recoil Starter (pull rope)** – Manual-starting method. Pull the starter grip until resistance is felt, then pull briskly and smoothly.
18. **Engine Oil Filler Cap** – Remove this cap/dipstick when the adding of engine oil is required. See Table 6 for recommended type engine oil.
19. **Engine Oil Drain Plug** – Remove this drain plug when draining of the oil from the engine crankcase is required. Fill with recommended type oil as listed in Table 6.
20. **Air Cleaner** – Prevents dirt and other debris from entering the fuel system. Remove wing-nut on top of air filter canister to gain access to filter element. **NEVER** run the engine without an air cleaner.
21. **Fuel Tank Cap** – Remove this cap to add unleaded gasoline to the fuel tank. **Replenish** with **clean unleaded** gasoline. Make sure cap is tightened securely. **DO NOT** over fill.
22. **Fuel Gauge** – This gauge is located on top of the fuel tank. Read this gauge to determine when fuel is **low**.
23. **Fuel Tank** – Fuel tank capacity is 5 gallons (19 liters).



This **HONDA** engine is equipped with a low oil shutdown capability. A built in sensor will automatically turn off the engine should the oil level fall below a safe operating condition. Make sure the generator is placed on level ground. Placing the generator on level ground will ensure that the low oil sensor will function properly.

! DANGER

Adding fuel to the tank should be done only when the engine is stopped and has had an opportunity to cool down. In the event of a fuel spill, **DO NOT** attempt to start the engine until the fuel residue has been completely wiped up, and the area surrounding the engine is dry. If generator is placed in a truck bed with a plastic liner, **REMOVE** generator from truck bed and place on ground (Figure 5) to refuel. This possibility exist of **fire** or **explosion** due to static electricity.

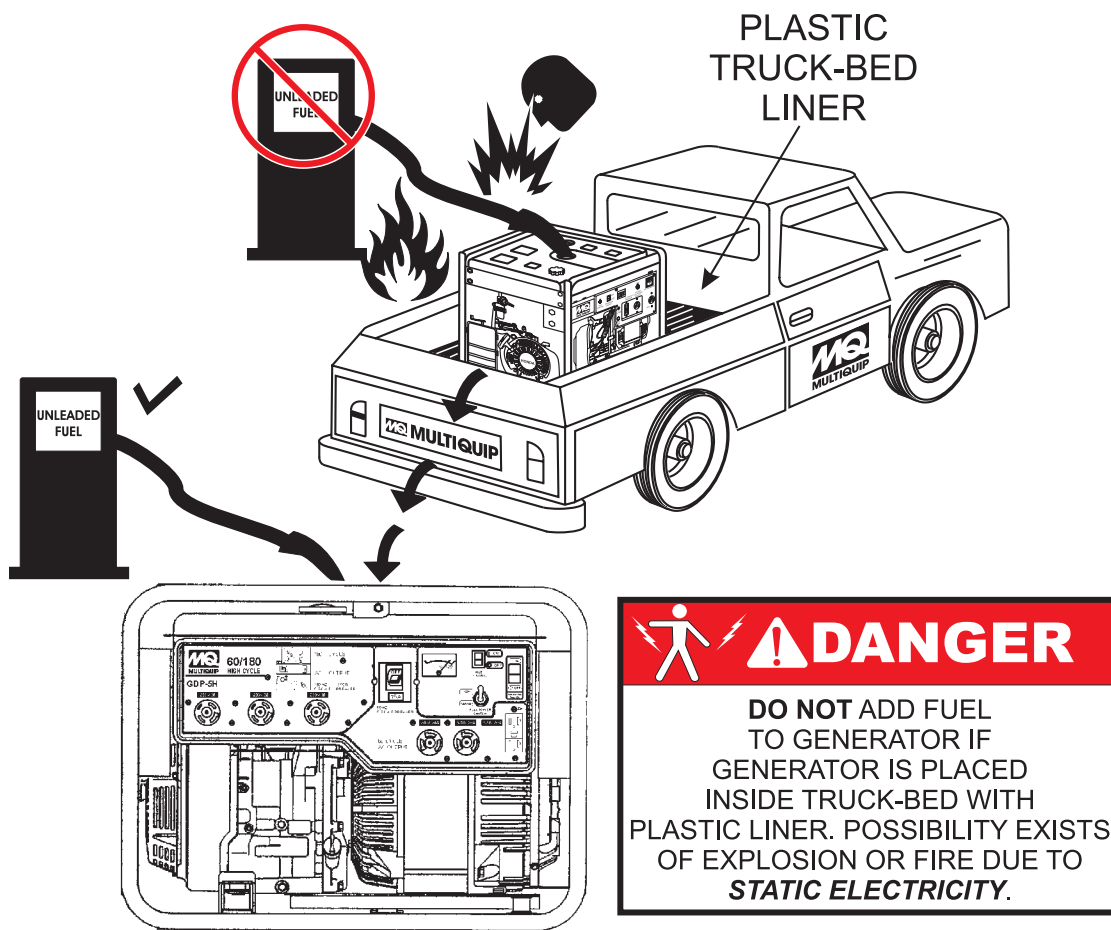

Figure 5. Generator Refueling

Outdoor Installation

Install the generator/welder in a area that is free of **debris**, **bystanders**, and **overhead obstructions**. Make sure the generator is on secure level ground so that it cannot slide or shift around. Also install the generator in a manner so that the exhaust will not be discharged in the direction of nearby homes.

The installation site must be relatively free from moisture and dust. All electrical equipment should be protected from excessive moisture. Failure to do will result in deterioration of the insulation and will result in short circuits and grounding.

Foreign materials such as dust, sand, lint and abrasive materials have a tendency to cause excessive wear to engine and alternator parts.

! CAUTION

Pay close attention to ventilation when operating the generator inside tunnels and caves. The engine exhaust contains noxious elements.



Mounting

The generator should always be mounted on a flat level surface to isolate vibration of the generator when it is running. **DO NOT** place the generator on slopes, the possibility exists that the generator could slide.

! CAUTION

An electric shock is apt to happen when vibrators are used. Pay close attention to handling when operating vibrators and always use rubber boots and gloves to insulate the body from a short circuit.



Indoor Installation

Exhaust gases from gasoline engines are extremely poisonous. Whenever an engine is installed indoors the exhaust fumes must be vented to the outside. The engine should be installed at least two feet from any outside wall. Using an exhaust pipe which is too long or too small can cause excessive back pressure which will cause the engine to heat excessively and possibly burn the valves.

Eliminate the danger of deadly carbon monoxide gas. Remember that exhaust fumes from any gasoline engine are very poisonous if discharged in a closed room, but harmless if allowed to mix with the outside air. If the generator is installed indoors, you must make provisions for venting the engine exhaust to the outside of the building.

Generator Grounding

To guard against electrical shock and possible damage to the equipment, it is important to provide a good **EARTH** ground. Always use the ground terminal on the generator to ground the generator. Ground the generator from its ground connector so that the resistance to ground is 500 ohms or less.

Article 250 (Grounding) of the National Electrical Code (NEC) provides guide lines for proper grounding and specifies that the cable ground shall be connected to the grounding system of the building as close to the point of cable entry as practical.

NEC articles 250-64(b) and 250-66 set the following grounding requirements:

1. Use one of the following wire types to connect the generator to earth ground.
 - a. Copper - 10 AWG (5.3 mm²) or larger.
 - b. Aluminum - 8 AWG (8.4 mm²) or larger.
2. When grounding the generator (Figure 3) connect the ground cable between the lock washer and the nut on the generator and tighten the nut fully. Connect the other end of the ground cable to earth ground.
3. NEC article 250-52(c) specifies that the earth ground rod should be buried a minimum of 8 ft. into the ground.

Connecting the Ground

The nut and ground terminal on the generator should always be used to connect the generator to a suitable ground. The ground cable should be #8 size wire minimum.

At the generator, connect the terminal of the ground cable between the lock washer and the nut (Figure 6) and tighten the nut fully. Connect the other end of the ground cable to a suitable earth ground (ground rod).

! DANGER



Some of the MQ GDP5H portable generators (S/N 5541050 and below) have been configured with the ground of the **armature floating**. This configuration may lead to an electrical shock if the generator is not properly grounded. To prevent electrical shock, **ALWAYS** connect generator to a good earth ground.

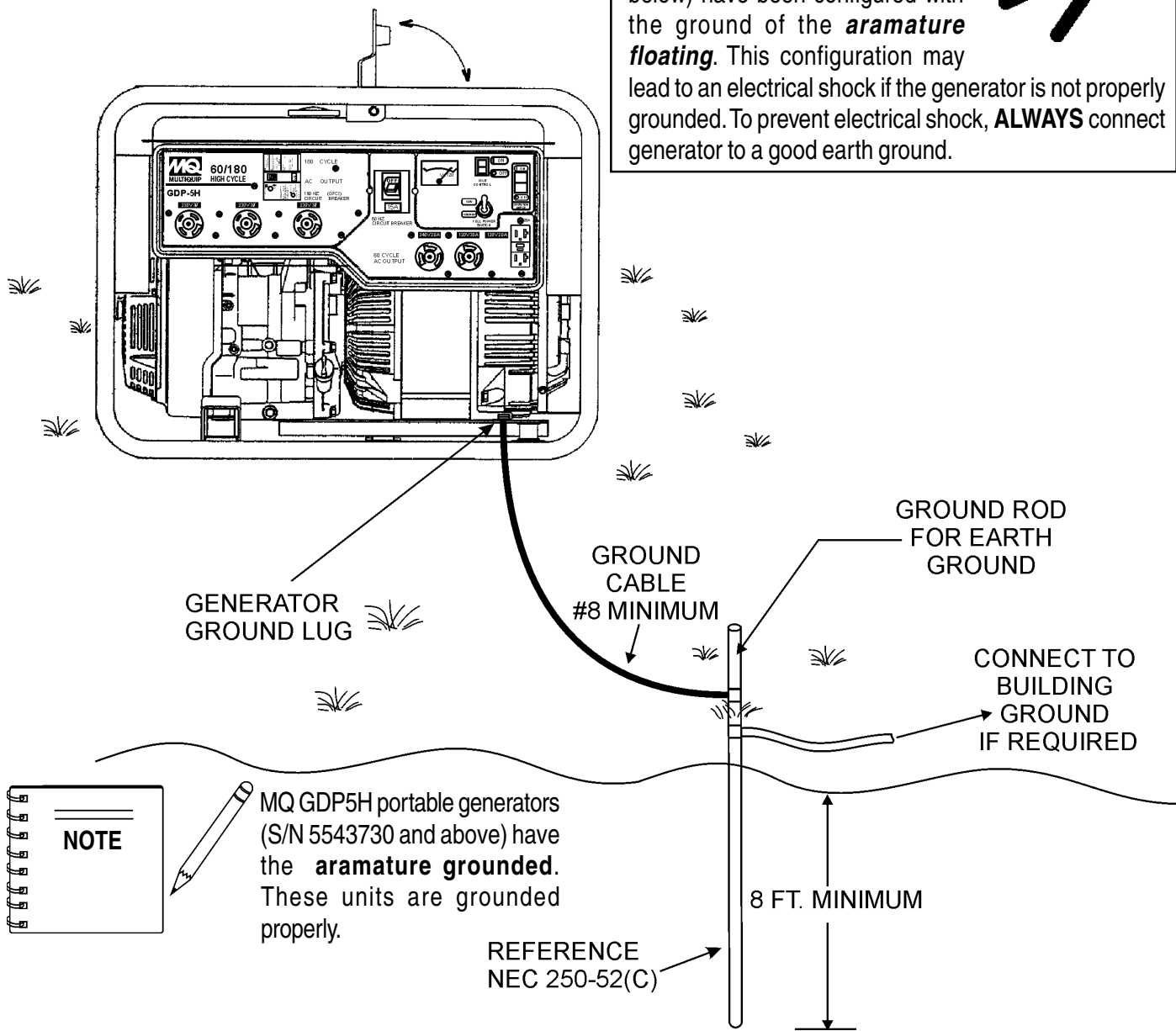

Figure 6. Generator Grounding

General Inspection Prior to Operation

Ground Power Tools

When using power tools or electrical equipment requiring AC power from the generator, make sure connecting (power tool) cable (Figure 7) has a ground as shown in Figure.

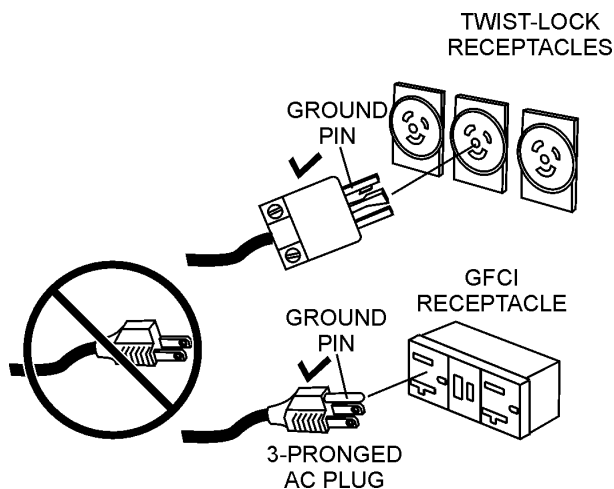
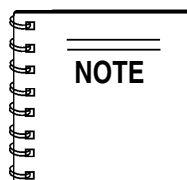

Figure 7. Ground Cables/Plugs

Extension Cable

When electric power is to be provided to various tools or loads at some distance from the generator, extension cords are normally used. Cables should be sized to allow for distance in length and amperage so that the voltage drop between the generator and point of use (load) is held to a minimum. Use the cable selection chart (Tables 4 and 5) as a guide for selecting proper cable size.



Never! use power tools or equipment that do not have a ground capability, the possibility exists of **electrocution, electrical shock or burn**, which can cause **severe bodily harm** or even **DEATH!**

60 and 180 Hz Circuit Breakers

To protect the generator from an overload, circuit breakers are provided for both **60** and **180 Hz** operation. Make sure to switch these circuit breakers to the "OFF" position prior to starting the engine.

Table 4. Cable Selection (60 Hz, Single Phase Operation)

Current In Amperes	Load In Watts		Maximum Allowable Cable Length			
	120 Volts	240 Volts	#10 Wire	#12 Wire	#14 Wire	#16 Wire
2.5	300	600	1000 ft.	600 ft.	375 ft.	250 ft.
5	600	1200	500 ft.	300 ft.	200 ft.	125 ft.
7.5	900	1800	350 ft.	200 ft.	125 ft.	100 ft.
10	1200	2400	250 ft.	150 ft.	100 ft.	
15	1800	3600	150 ft.	100 ft.	65 ft.	
20	2400	4800	125 ft.	75 ft.	50 ft.	

CAUTION: Equipment damage can result from low voltage.

Table 5. Cable Selection (180 Hz, 3-Phase Operation)

Load	Length (ft.)					
	50	100	150	200	250	300
3 kVA	#14 Wire	#14 Wire	#14 Wire	#12 Wire	#12 Wire	#10 Wire
2 kVA	#14 Wire	#14 Wire	#14 Wire	#14 Wire	#14 Wire	#12 Wire
1 kVA	#14 Wire	#14 Wire	#14 Wire	#14 Wire	#14 Wire	#14 Wire

GDP-5H — PRE-INSPECTION (ENGINE)

CAUTION

NEVER operate the generator in a confined area or enclosed area structure that does not provide ample *free flow of air*.



ALWAYS wear approved eye and hearing protection before operating the generator.

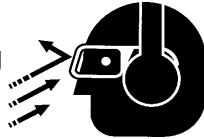

Before Starting

1. Read safety instructions at the beginning of manual.
2. Clean the generator, removing dirt and dust, particularly the engine cooling air inlet, carburetor and air cleaner.
3. Check the air filter for dirt and dust. If air filter is dirty, replace air filter with a new one as required.
4. Check carburetor for external dirt and dust. Clean with dry compressed air.
5. Check fastening nuts and bolts for tightness.



Engine Oil Check

1. To check the engine oil level, place the generator on secure level ground with the engine stopped.
2. Remove the filler dipstick from the engine oil filler hole (Figure 8) and wipe clean.

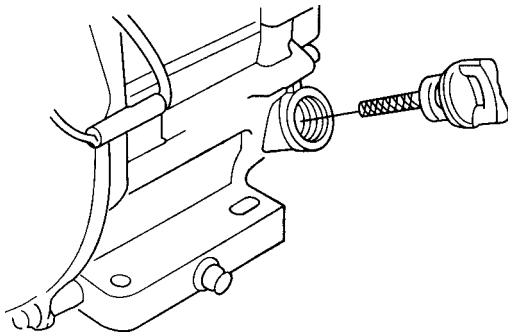

Figure 8. Engine Oil Dipstick (Removal)

3. Insert and remove the dipstick without screwing it into the filler neck. Check the oil level shown on the dipstick.
4. If the oil level is low (Figure 9), fill to the edge of the oil filler hole with the recommended oil type (Table 6). Maximum oil capacity is 1.16 quarts (1.1 liters)

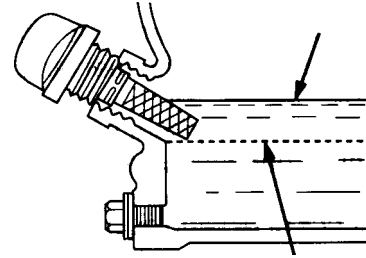

Figure 9. Engine Oil Dipstick (Oil Level)

Table 6. Oil Type

Season	Temperature	Oil Type
Summer	25°C or Higher	SAE 10W-30
Spring/Fall	25°C~10°C	SAE 10W-30/20
Winter	0°C or Lower	SAE 10W-10

DANGER EXPLOSIVE FUEL

Motor fuels are highly flammable and can be dangerous if mishandled. **DO NOT** smoke while refueling. **DO NOT** attempt to refuel the generator if the engine is *hot!*, *running or in the dark*.

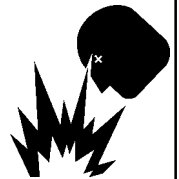

Fuel Check

1. Close the fuel cock before filling the fuel tank.
2. Remove the fuel cap located on top of fuel tank.
3. Read the fuel gauge located on top of the fuel tank (Figure 10) to determine if the fuel level is low. If fuel is low, replenish with *clean unleaded fuel*.

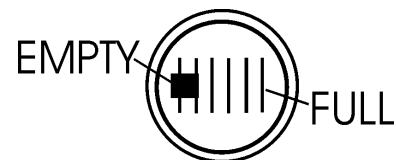

Figure 10. Fuel Gauge

4. When refueling, be sure to use a strainer for filtration. **DO NOT** top-off fuel. **DO NOT** fill the tank beyond capacity. Wipe up any spilled fuel *immediately!*

GDP-5H — INITIAL START-UP (ENGINE)

CAUTION

DO NOT attempt to operate this generator until the Safety, General Information and Inspection sections of this manual have been **read and thoroughly understood**.



This section is intended to assist the operator with the **initial start-up** of the portable generator. It is extremely important that this section be read carefully before attempting to use the generator in the field.

Before Starting the Engine

1. Be sure to **disconnect all electrical loads** from the generator prior to starting the engine.
2. **NEVER** start the engine with the 60 or 180 Hz circuit breakers in the "ON" position. Place both circuit breakers (Figure 11) in the **OFF** position.

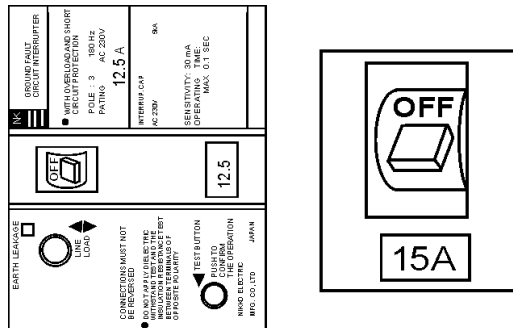

Figure 11. 60 and 180 Hz Circuit Breakers (OFF Position)

Starting the Engine

1. Place the engine **fuel valve lever** (Figure 12) to the "ON" position."

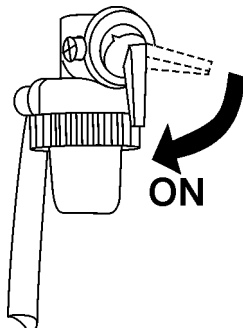

Figure 12. Engine Fuel Valve Lever (ON Position)

2. Place the **choke lever** (Figure 13) in the "CLOSED" position if starting a **cold engine**.

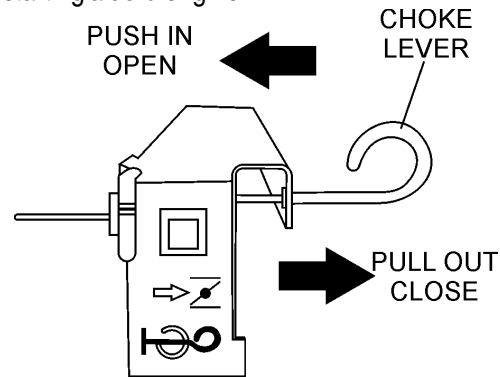

Figure 13. Choke Lever

3. Place the **choke lever** (Figure 13) in the "OPEN" position if starting a **warm engine** or the **temperature is warm**.
4. Place the **generator ON/OFF switch** (Figure 14) in the "ON" position.

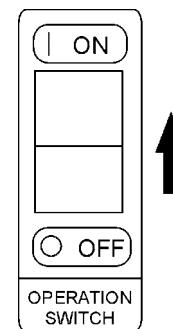

Figure 14. Generator On/Off Switch (ON)

5. Grasp the starter grip (Figure 15) and slowly pull it out. The resistance becomes the hardest at a certain position, corresponding to the compression point. Pull the starter grip briskly and smoothly for starting.

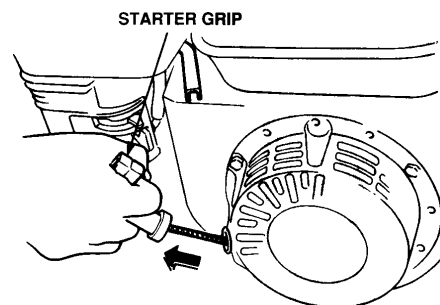

Figure 15. Starter Grip

CAUTION

DO NOT pull the starter rope all the way to the end.

DO NOT release the starter rope after pulling. Allow it to rewind as soon as possible.

GDP-5H — INITIAL START-UP/GENERATOR OPERATION

- If the engine has started, slowly return the choke lever (Figure 13) to the "OPEN" position. If the engine has not started repeat steps 1 through 5.
- Before the generator is placed into operation, run the engine for 3-5 minutes. Check for abnormal smells, fuel leaks, and noises that would associate with loose components.
- Place the **idle control switch** (Figure 16) in the "OFF" (down) position. This will allow the engine speed to run at speed about 3600 RPM's

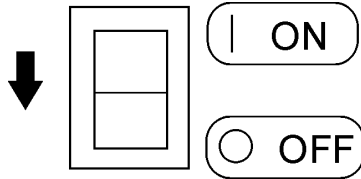

Figure 16. Idle Control Switch (Off)

NOTE Placing the **idle control switch** in the **OFF** position (Figure 16) allows the engine to operate at a maximum speed of about 3600 RPM's. When the idle control switch is placed in the up position (**ON**) (Figure 17), the generator will run at idle speed (2200 RPM's) until a load is applied, at that time the engine speed will increase to 3600 RPM's as long as the load is being applied. When the load is not in use, the engine speed will drop back to the idle mode after about 3 seconds.

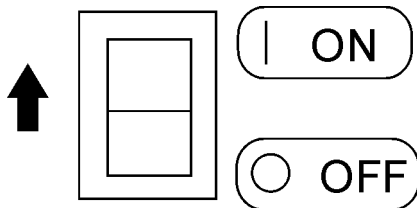

Figure 17. Idle Control Switch (On)

60 Hz Operation

- Place the 60 Hz, 15 amp circuit breaker (Figure 18) in the **ON** position.

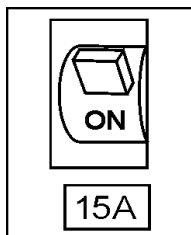

Figure 18. 60 Hz Circuit Breaker (ON)

- Place the full power switch (Figure 19) in the 120V position (up).

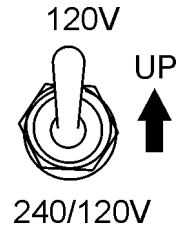

Figure 19. Full Power Switch 120 V Position (Up)

NOTE When the **full power switch** is in the 120 V position, the 240V twist-lock receptacle cannot be used.

- Read the **voltmeter** on the front panel of the generator (Figure 20) and verify that 120 VAC is present at the 120V twist-lock and GFCI duplex receptacles. For additional verification of voltage, an external voltmeter can be used to measure the output voltage as shown in Figure 20.

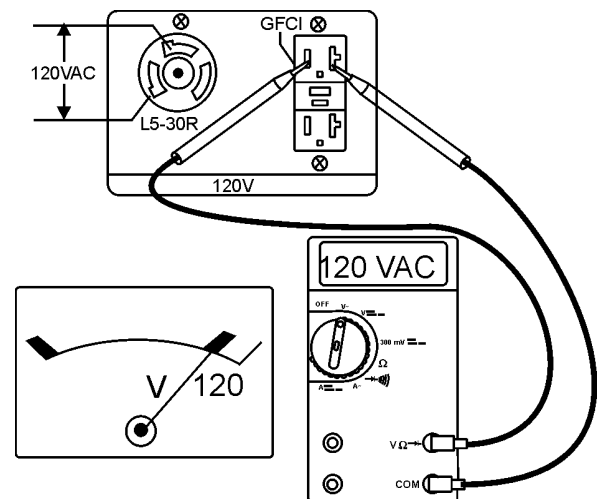

Figure 20. 120 V and GFCI Receptacles

- Place the full power switch (Figure 21) in the 240V position (down).

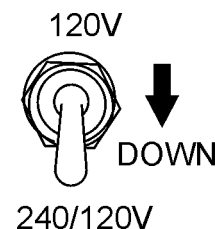

Figure 21. Full Power Switch 240/120 V Position (Down)

GDP-5H — INITIAL START-UP/GENERATOR OPERATION

5. Read the **voltmeter** on the front panel of the generator (Figure 22) and verify that 240 VAC is present at the 240V twist-lock receptacle. Using an external voltmeter verify that 120V is present at the 120V twist-lock and GFCI duplex receptacles.

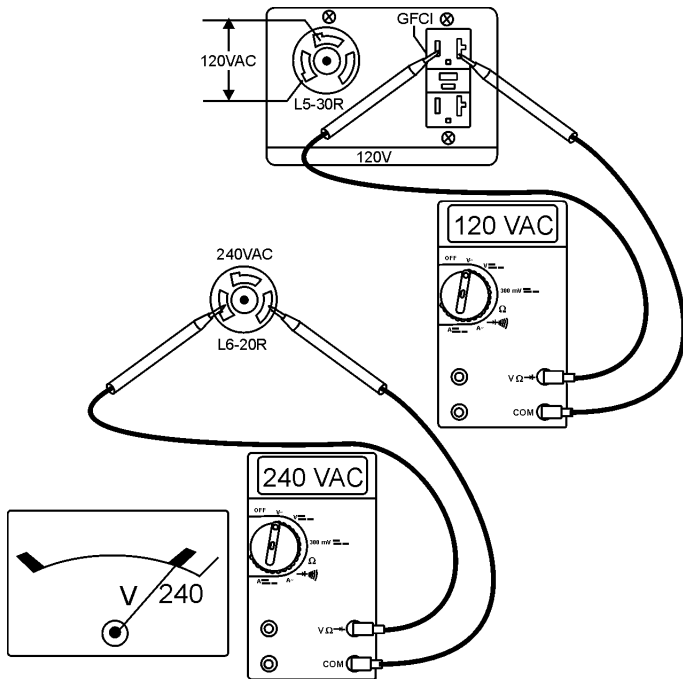

Figure 22. 60 Hz Output Receptacles



When the full power switch is in the 240 volt (down) position, you can take up to **half of the rated power** of the generating set at 120 volts from the GFCI duplex receptacle and up to half of the rated power of the set at 120 volts from the 120V twist-lock receptacle; or full rated power of the genset at 240 volts from the 240V twist-lock receptacle.



When using a combination of dual receptacles, total load should not exceed the rated capacity of the generator.

Connecting the Load

1. If small wattage power tools are required, connect them to the 60 Hz output receptacles at this time.

180 Hz Operation

1. Place the 180 Hz, 12.5 amp circuit breaker (Figure 23) in the **ON** position.

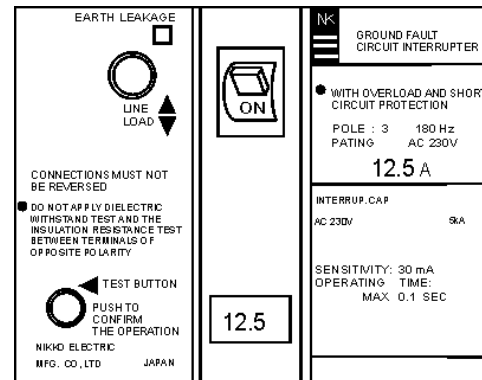

Figure 23. 60 and 180 Hz Breakers (ON)

5. Use an external voltmeter to measure the 230 VAC output voltage on the 180 Hz twist-lock receptacles as shown in Figure 24.

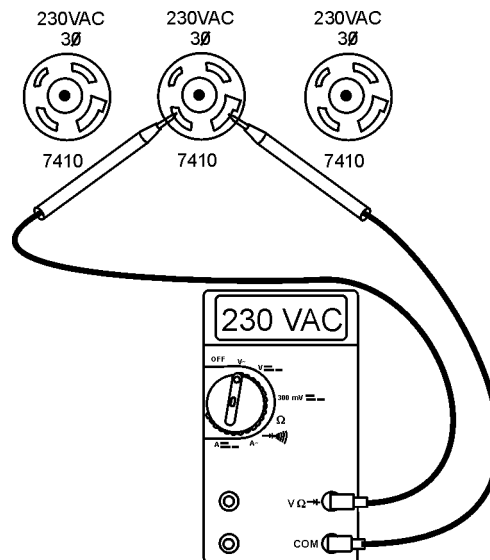
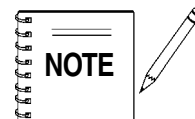

Figure 24. 180 Hz Output Receptacles



When using the 180 Hz output receptacles, the AC voltmeter on the generator cannot be used for monitoring of the 3-phase voltage.

Connecting the Load

1. If high-cycle vibrators are going to be used, connect them to the 180 Hz output receptacles at this time.

GDP-5H — SHUTDOWN/ LONG TERM STORAGE

Stopping the Engine

1. Place both the 60 and 180 Hz circuit breakers (Figure 25) in the **OFF** position.

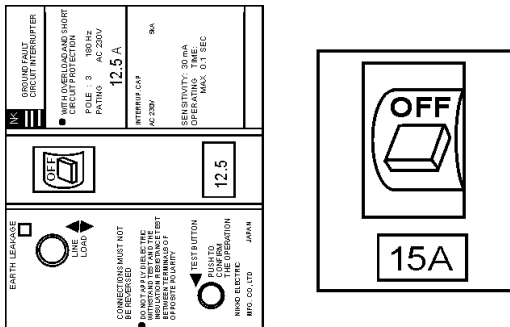

Figure 25. 60 and 180 Hz Breakers (Off)

2. Place the **idle control switch** (Figure 26) in the **OFF** position.

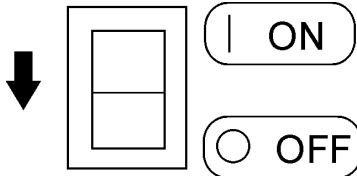

Figure 26. Idle Control Switch (Off)

3. Let the engine run at idle with no load for 2-3 minutes.
4. To shut-down the engine, place the generator **ON/OFF** switch (Figure 27) in the **OFF** position

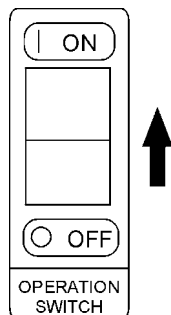

Figure 27. Generator On/Off Switch (Off)

5. Place the engine **fuel valve lever** (Figure 28) to the "OFF" position."

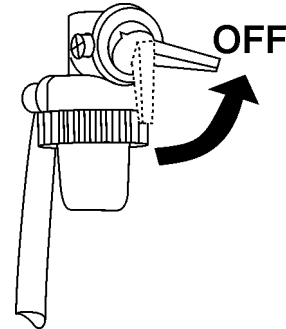

Figure 28. Engine Fuel Valve Lever (OFF Position)

6. Remove the **load** from the generator.

Generator Storage

For storage of the generating set for over 30 days, the following is required:

- Drain the fuel tank completely, or add STA-BIL to the fuel.
- Run the engine until the gasoline in the carburetor is completely consumed.
- Completely drain the oil from the crankcase and refill with fresh oil.
- Remove the spark plug, pour 2 or 3 cc of SAE 30 oil into the cylinder and crank slowly to distribute the oil.
- Slowly rotate the engine a few times with the starter rope and install a new spark plug.
- Pull out the starter rope slowly and stop at the compression point.
- Clean all external parts of the generating set with a cloth.
- Cover the generating set and store in a clean, dry place.

GDP-5H — MAINTENANCE (ENGINE)

Use Table 7 as a general maintenance guideline when servicing your engine. For more detail engine maintenance information, refer to the Honda engine owner's manual supplied with your engine.

Table 7. Engine Maintenance Schedule

DESCRIPTION (3)	OPERATION	BEFORE	FIRST MONTH OR 10 HRS.	EVERY 3 MONTHS OR 25 HRS.	EVERY 6 MONTHS OR 50 HRS.	EVERY YEAR OR 100 HRS.	EVERY 2 YEARS OR 200 HRS.
Engine Oil	CHECK	X					
	CHANGE		X				
Air Cleaner	CHECK	X					
	CHANGE			X (1)			
All Nuts & Bolts	Re-tighten If Necessary	X					
Spark Plug	CHECK-CLEAN				X		
	REPLACE						X
Cooling Fins	CHECK				X		
Spark Arrester	CLEAN					X	
Fuel Tank	CLEAN					X	
Fuel Filter	CHECK					X	
Idle Speed	CHECK-ADJUST					X (2)	
Valve Clearance	CHECK-ADJUST						X (2)
Fuel lines	CHECK	Every 2 years (replace if necessary) (2)					

(1) Service more frequently when used in **DUSTY** areas.

(2) These items should be serviced by your service dealer, unless you have the proper tools and are mechanically proficient. Refer to the HONDA Shop Manual for service procedures.

(3) For commercial use, log hours of operation to determine proper maintenance intervals.

Maintenance

Perform the scheduled maintenance procedures as defined by Table 6 and below:

DAILY

- Thoroughly remove dirt and oil from the engine and control area. Clean or replace the air cleaner elements as necessary. Check and retighten all fasteners as necessary. Check the gearbox for oil leaks. Repair or replace as needed.

WEEKLY

- Remove the fuel filter cap and clean the inside of the fuel tank.
- Remove or clean the filter at the bottom of the tank.
- Remove and clean the spark plug (Figure 29), then adjust the spark gap to 0.024 ~0.028 inch (0.6~0.7 mm). This unit has electronic ignition, which requires no adjustments.

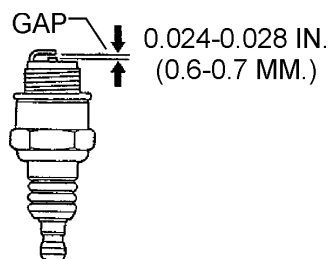

Figure 29. Spark Plug Gap

ENGINE OIL

- Drain the engine oil when the oil is **warm** as shown in Figure 30.
- Remove the oil drain bolt and sealing washer and allow the oil to drain into a suitable container.
- Replace engine oil with recommended type oil as listed in Table 6. For engine oil capacity, see Table 2 (engine specifications). **DO NOT** overfill.
- Install drain bolt with sealing washer and tighten securely.

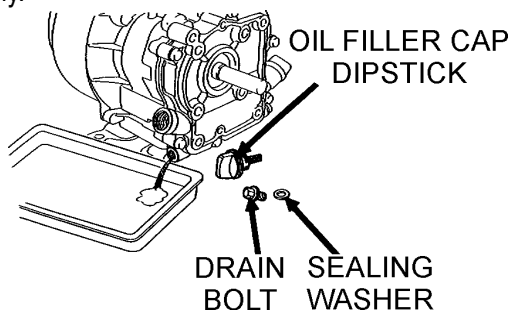

Figure 30. Engine Oil (Draining)

! DANGER

DO NOT use gasoline as a cleaning solvent, because that would create a risk of fire or explosion.



ENGINE AIR CLEANER

- Remove the air cleaner cover and foam filter element as shown in Figure 31.
- Clean foam element in warm, soapy water or nonflammable solvent. Rinse and dry thoroughly. Dip the element in clean engine oil and completely squeeze out the excess oil from the element before installing.

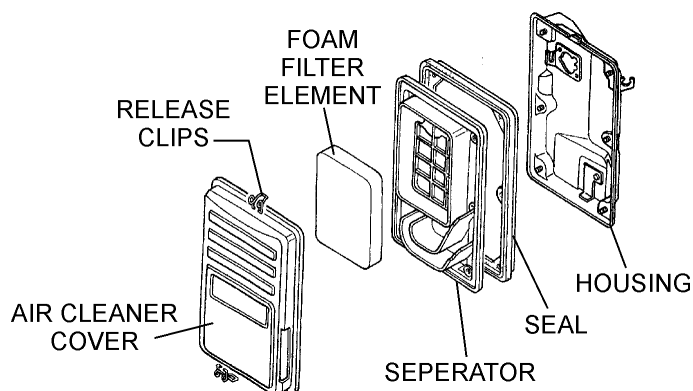
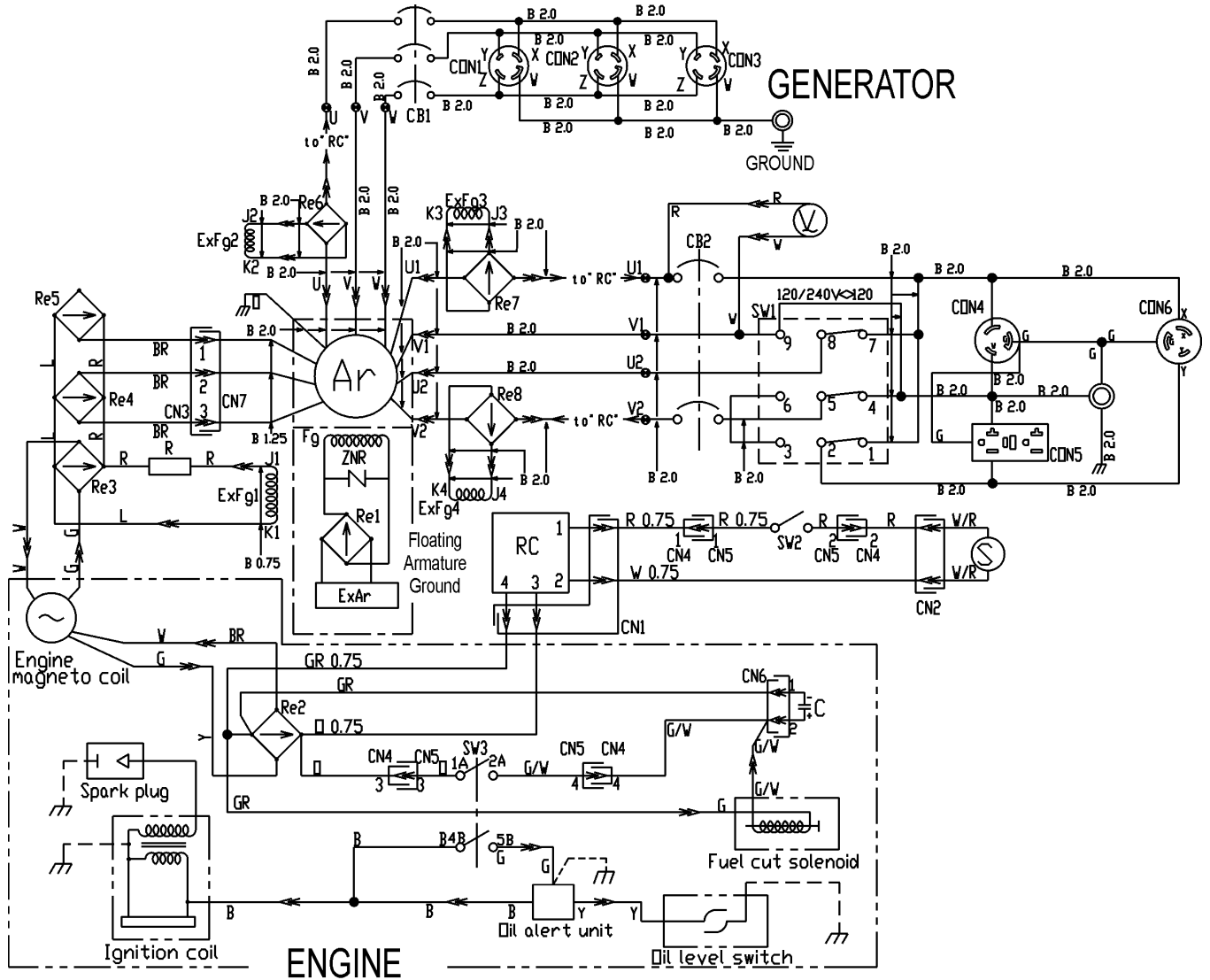

Figure 31. Engine Air Cleaner

GDP-5H — WIRING DIAGRAM (GENERATOR) S/N 5541049 AND BELOW



COLOR CODE			
WIRE COLOR	WIRE COLOR	WIRE COLOR	WIRE COLOR
B	BLACK	R	RED
L	BLUE	W	WHITE
BR	BROWN	Y	YELLOW
G	GREEN	LB	LIGHT BLUE
GR	GRAY	LG	LIGHT GREEN
V	VIOLET	O	ORANGE
P	PINK		

SYMBOL	DESIGNATION
Ar	MAIN GENERATOR ARMATURE WINDING
Fg-P, N	FIELD WINDING
ExFg1	EXCITATION WINDING
CON1~3	RECEPTACLE 120/208V, 20A
CON4	RECEPTACLE L5-30R, 30A, 125V
CON5	RECEPTACLE 5-20R, GFCI 20A, 125V
CON6	RECEPTACLE L6-20R, 20A, 250A
V	AC.VOLTMETER 120/240
Re	RECTIFIER
Re2~5	RECTIFIER
Re6~8	RECTIFIER
CB1	EARTH LEAKAGE CIRCUIT BREAKER (30mA) 12.5A
CB2	CIRCUIT BREAKER 15A
SW1	FULL POWER SWITCH
SW2	IDLE CONTROL SWITCH
SW3	OPERATION SWITCH
RC	IDLE CONTROL DEVICE
S	IDLE CONTROL SOLENOID
R	RESISTOR
C	CAPACITOR
	TERMINAL BOARD

CONNECTOR VIEWED AT WIRING SIDE

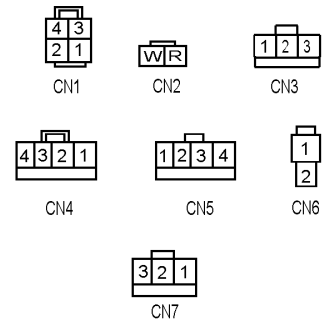
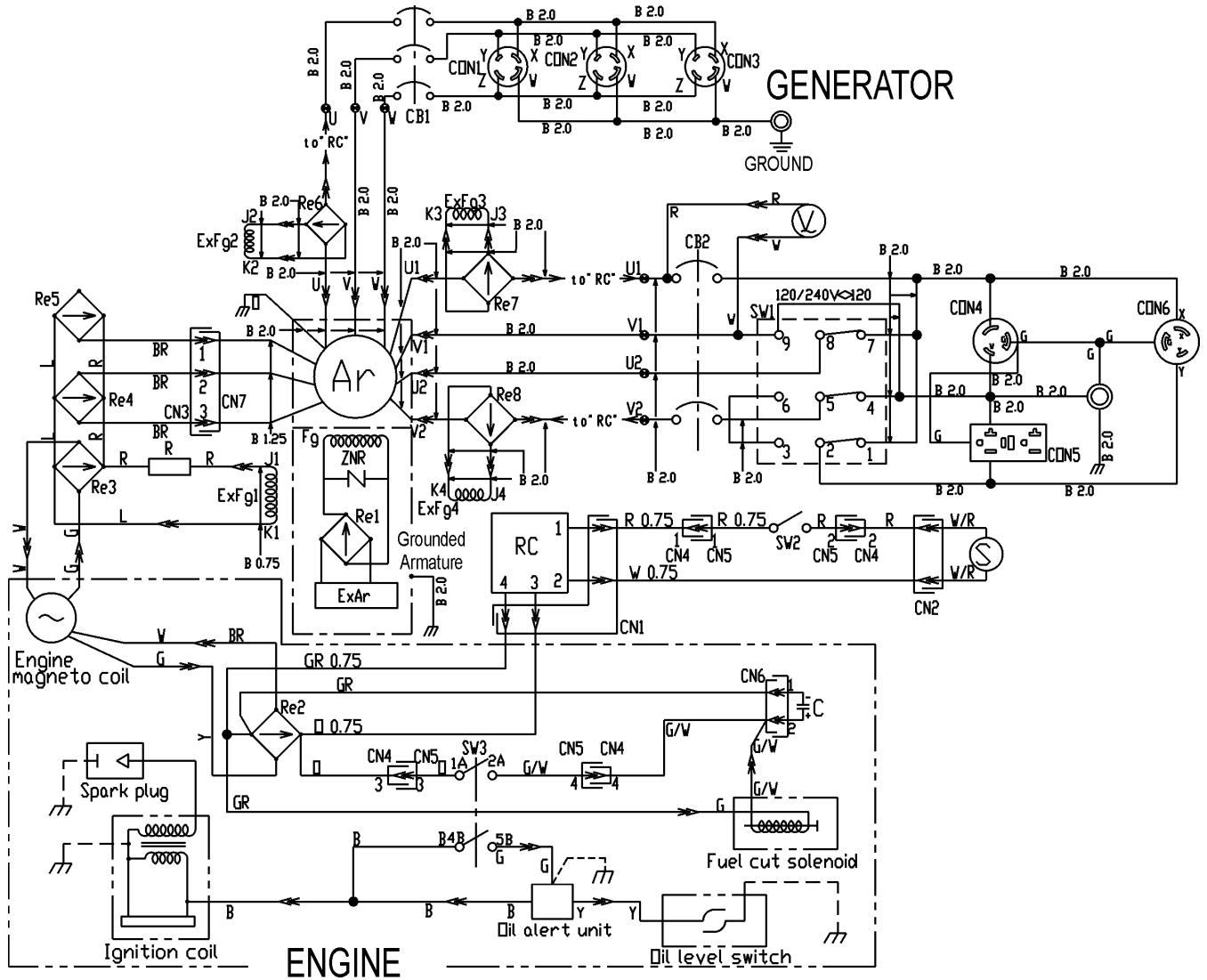

Figure 32. Generator Wiring Diagram (S/N 5541049 and below)

GDP-5H — WIRING DIAGRAM (GENERATOR) S/N 5543731 AND ABOVE



COLOR CODE			
WIRE COLOR		WIRE COLOR	
B	BLACK	R	RED
L	BLUE	W	WHITE
BR	BROWN	Y	YELLOW
G	GREEN	LB	LIGHT BLUE
GR	GRAY	LG	LIGHT GREEN
V	VIOLET	O	ORANGE
P	PINK		

SYMBOL	DESIGNATION
Ar	MAIN GENERATOR ARMATURE WINDING
Fg-P, N	FIELD WINDING
ExFg1	EXCITATION WINDING
CON1~3	RECEPTACLE 120/208V, 20A
CON4	RECEPTACLE L5-30R, 30A, 125V
CON5	RECEPTACLE 5-20R, GFCI 20A, 125V
CON6	RECEPTACLE L6-20R, 20A, 250A
V	AC VOLT METER 120/240
Re	RECTIFIER
Re2~5	RECTIFIER
Re6~8	RECTIFIER
CB1	EARTH LEAKAGE CIRCUIT BREAKER (30mA) 12.5A
CB2	CIRCUIT BREAKER
SW1	FULL POWER SWITCH
SW2	IDLE CONTROL SWITCH
SW3	OPERATION SWITCH
RC	IDLE CONTROL DEVICE
S	IDLE CONTROL SOLENOID
R	RESISTOR
C	CAPACITOR
⊙	TERMINAL BOARD

CONNECTOR VIEWED AT WIRING SIDE

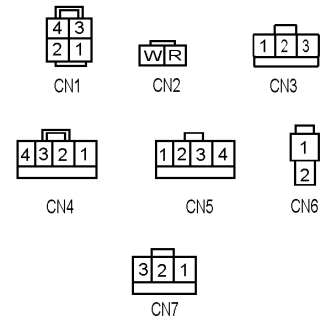

Figure 33. Generator Wiring Diagram (S/N 5543731 and above)

GDP-5H — TROUBLESHOOTING (ENGINE)

Practically all breakdowns can be prevented by proper handling and maintenance inspections, but in the event of a breakdown, please take a remedial action following the diagnosis based on the Engine Troubleshooting (Table 8) and

Generator Troubleshooting (Table 9) information shown below and on the proceeding pages. If the problem cannot be remedied, please leave the unit just as it is and consult our company's business office or service plant.

TABLE 8. ENGINE TROUBLESHOOTING

SYMPTOM	POSSIBLE PROBLEM	SOLUTION
Poor starting	Inspect carburetor to see if fuel is reaching it?	Check fuel line
	No Fuel?	Add Fuel
	Water in fuel tank?	Flush or replace fuel tank.
	Fuel filter clogged?	Replace fuel filter
	Stuck carburetor?	Check float mechanism.
	Spark plug is red?	Spark plug is fouled. Check transistor ignition unit.
	Spark plug is blue-white?	Insufficient compression, injected air leaking. Carburetor jets are clogged (overflow).
	No spark present at tip of spark plug?	Transistor ignition unit broken, high voltage cord cracked or broken. Start/Stop switch broken. Replace spark plug if fouled.
	No oil?	Add oil as required.
	Oil pressure alarm lamp blinks upon starting?	Check Automatic shutdown circuit "oil sensor".
Insufficient power output "no compression"	Engine will not turn over?	Replace cylinder and piston and if necessary axle joint.
	Cylinder head connecting bolts loose?	Tighten cylinder head connecting bolts.
	Cylinder head gasket damaged?	Replace cylinder head gasket.
	Malfunction of valve seat?	Re-seat valves.
	Spark plug is loose?	Replace spark plug.
	Worn piston rings?	Replace piston rings.
Insufficient power output "compression"	Malfunction in air-cleaner system, air filter clogged?	Clean or replace air filter.
	Air leaking in from interface between carburetor and cylinder head?	Tighten bolts between carburetor and cylinder head. Replace cylinder head gasket.
	Malfunction in fuel system?	Clean or replace fuel filter. Clean or replace carburetor. Check carburetor float.

TABLE 8. ENGINE TROUBLESHOOTING (CONTINUED)

SYMPTOM	POSSIBLE PROBLEM	SOLUTION
Insufficient power output "compression" and overheats	Malfunction in cooling fan?	Check or replace cooling fan.
	Air in-take filter clogged?	Clean or replace air in-take filter.
Burns to much fuel	Over accumulation of exhaust products?	Clean and check valves. Check muffler, replace if necessary.
	Wrong spark plug?	Replace spark plug with manufactures suggested type spark plug.
Exhaust color is continously "WHITE"	Lubricating oil is wrong viscosity?	Replace lubricating oil with correct viscosity.
	Worn rings?	Replace rings
Exhaust color is continously "BLACK"	Air cleanner clogged?	Clean or replace air cleaner.
	Choke valve has not been set to the correct position?	Adjust choke valve to the correct position.
	Carburetor defective, seal on carburetor broken?	Replace carburetor or seal.
	Poor carburetor adjustment "engine runs too rich?"	Adjust carburetor.

GDP-5H — TROUBLESHOOTING (GENERATOR)

TABLE 9. GENERATOR TROUBLESHOOTING

SYMPTOM	POSSIBLE PROBLEM	SOLUTION
Low voltage	Engine speed too low?	Raise engine speed to rated RPM.
Low voltage. Engine speed normal 3650 RPM (unloaded), 2500 RPM (idle)	AC voltmeter not working?	Replace Ac voltmeter.
	Control box internal wiring malfunction?	Check control box wiring.
	Defective ignition coil?	Check red and green ignition wires. Replace ignition wires if necessary.
	Rotor winding malfunction?	Check or replace rotor.
	Stator winding malfunction?	Check or replace stator.
	Leakage breaker malfunction?	Check or replace CB1 or CB2.
	Full power switch malfunction?	Check full power switch and full power switch circuit.
Voltage output too high.	Engine speed too high?	Lower engine speed to rated RPM.
Voltage output too high. Engine speed normal 3650 RPM (unloaded), 2500 RPM (idle)	Control box internal wiring malfunction	Check control box wiring.
Circuit breaker will not turn on "NO LOAD"	Defective circuit breaker?	Replace circuit breaker.
Circuit breaker will turn on "LOADED" but trips immediately.	Overload Condition?	Reduce load or replace breaker.
	Load circuit is shorted?	Check load circuit for short.
Does not accelerate from low to high "NO LOAD"	Stuck solenoid?	Check solenoid.
	Bad Idle control switch?	Check or replace idle control switch.
Does not accelerate from low to high "LOAD ACTIVE"	Idle control switch malfunction?	Check or replace idle control switch.
	Idle control device malfunction?	Check or replace idle control device.
	Control box internal wiring defective?	Check control box wiring.
Does not decelerate no "VOLTAGE OUTPUT".	Defective rotor windings?	Check or replace rotor.
	Defective solenoid?	Check or replace solenoid.
	Defective idle control device?	Check or replace idle control device.
	Defective solenoid?	Check or replace idle control device.
Does not decelerate but has "VOLTAGE OUTPUT".	Control box wiring malfunction?	Check control box wiring, replace any defective components.
	Defective solenoid?	Check or replace solenoid.
	Idle control device malfunction?	Check or replace idle control device.

GDP-5H — EXPLANATION OF CODE IN REMARKS COLUMN

How to read the marks and remarks used in this parts book.

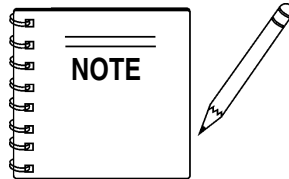

The contents of this catalog are subject to change without notice.

Items Found In the “Remarks” Column

Serial Numbers-Where indicated, this indicates a serial number range (inclusive) where a particular part is used.

Model Number-Where indicated, this shows that the corresponding part is utilized only with this specific model number or model number variant.

Items Found In the “Items Number” Column

All parts with same symbol in the number column, *, #, +, %, or ■, belong to the same assembly or kit.

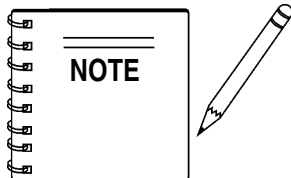

If more than one of the same reference number is listed, the last one listed indicates newest (or latest) part available.

GDP-5H — SUGGESTED SPARE PARTS

GDP-5H 1 TO 3 UNITS WITH HONDA GX340K1EDN2 ENGINE

1 to 3 Units

<u>Qty.</u>	<u>P/N</u>	<u>Description</u>
1	A9924800014	CAP FUEL TANK
1	A9924800004	FILTER FUEL
1	3015419604	SHOCK MOUNT
4	1665419004	SHOCK MOUNT
1	9807955846	SPARK PLUG
1	34150ZH7003	ALERT UNIT, OIL
2	28462ZV7003	ROPE, RECOIL
2	17211899000	ELEMENT AIR CLEANER

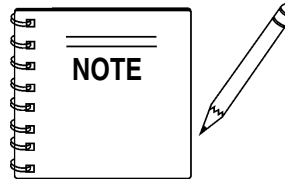

Part numbers on this Suggested Spare Parts List may supersede/replace the P/N shown in the text pages of this book.

GDP-5H — NAMEPLATE AND DECALS.

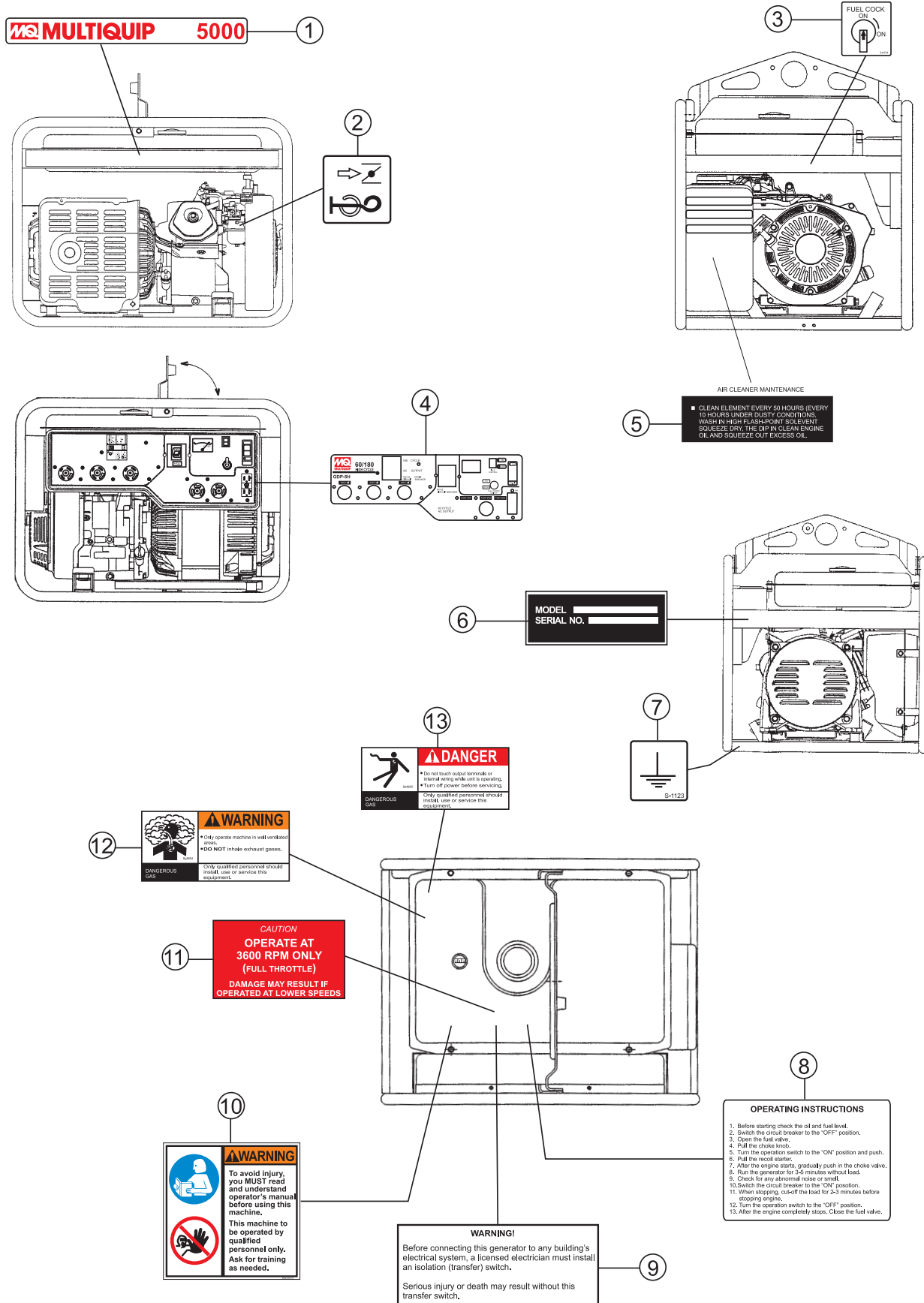

GDP-5H — NAMEPLATE AND DECALS.

NAME PLATE ASSY.

<u>NO.</u>	<u>PART NO.</u>	<u>PART NAME</u>	<u>QTY.</u>	<u>REMARKS</u>
1	A4561000103	DECAL; MQ MULTIQUIP 5000	1	
2	0600500047	DECAL; CHOKE	1	
3	1980680004	DECAL; FUEL COCK	1	S-3704
4	A4511200102	DECAL; CONTROL PANEL	1	A41120010
5	0600500045	DECAL; AIR CLEANER	1	
6		NAMEPLATE	1	CONTACT MQ PARTS DEPT.
7	0800628504	DECAL; GROUND	1	S-1123
8	A9521200104	DECAL; OPERATING INSTRUCTIONS	1	A92120010
9	0820610404	DECAL; WARNING	1	S-3627
10	A9511100004	DECAL; WARNING	1	A91110000
11	7900636004	DECAL; CAUTION OPER. AT 3600 RPM ONLY	1	S-4461
12	8700611804	DECAL; WARNING DANGEROUS GAS	1	S-4984
13	8700611904	DECAL; DANGER ELECTRICAL SHOCK HAZ.	1	S-4985

GDP-5H — GENERATOR ASSY.

GENERATOR ASSY.

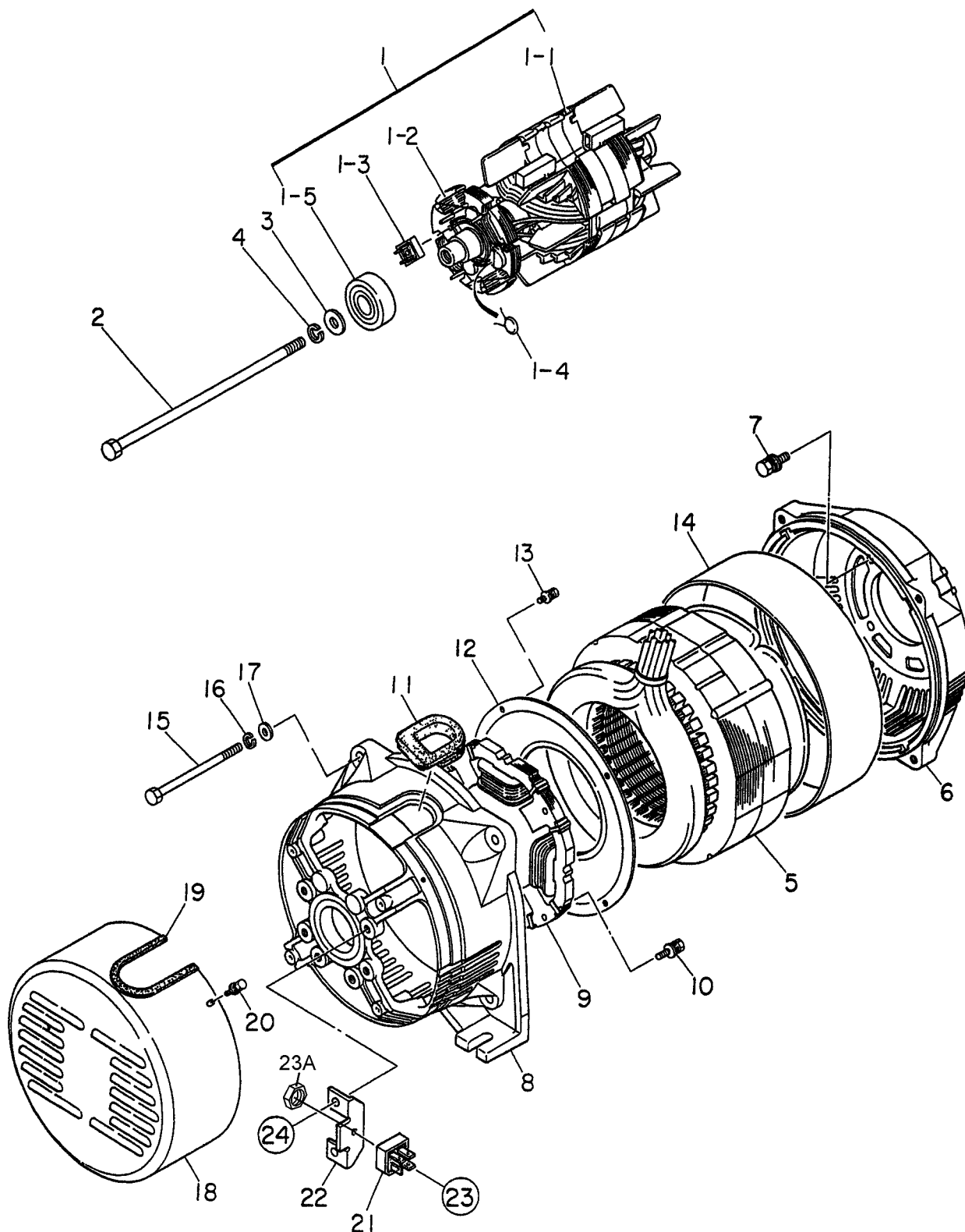

GDP-5H — GENERATOR ASSY.

GENERATOR ASSY.

<u>NO.</u>	<u>PART NO.</u>	<u>PART NAME</u>	<u>QTY.</u>	<u>REMARKS</u>
1*	7851000203	ROTOR ASSY.	1	INCLUDES ITEMS W/*
1-1*		FIELD ASSY.	1	NOT SOLD SEPERATELY
1-2*		ARMATURE ASSY. EXCITER	1	NOT SOLD SEPERATELY
1-3*	0601820037	RECTIFIER	1	S10VB60
1-4*	0601822640	SURGE ABSORBER	1	TNR15G471K
1-5*	0071206304	BEARING	1	6304DDU
2	7851017204	SET BOLT ROTOR	1	
3	0801086104	SET WASHER BEARING	1	
4	030210250	SPRING WASHER	1	REPLACES 0040010000
5	A4135000003	ARMATURE ASSY.	1	
6	7851315502	END BRACKET	1	
7	0017108020	HEX HEAD BOLT	4	
8	A4154000002	END BRACKET	1	
9	A4138000003	FIELD ASSY. EXCITER	1	
10	011208025	HEX HEAD BOLT	4	REPLACES P/N 0017108025
11	1961324003	GROMMET	1	
12	1961313003	GUIDE PANEL AIR	1	
13	0011305100	HEX HEAD BOLT	4	REPLACES P/N 0017105012
14	7851334204	COVER	1	
15	7851316804	SET BOLT STATOR	4	
16	030208200	SPRING WASHER	4	REPLACES P/N 0040008000
17	031108160	PLAIN WASHER	4	REPLACES P/N 0041208000
18	7851331103	COVER	1	
19	0310300090	SEAL	1	
20	0017105012	HEX HEAD BOLT	4	
21	0601820083	RECTIFIER, S25VB60	3	
22	A4184000004	BRACKET	3	
23	0027104020	MACHINE SCREW	3	
23A	0038404000	HEX NUT	3	
24	0017108015	HEX HEAD BOLT	6	

GDP-5H — CONTROL BOX ASSY.

CONTROL BOX ASSY.

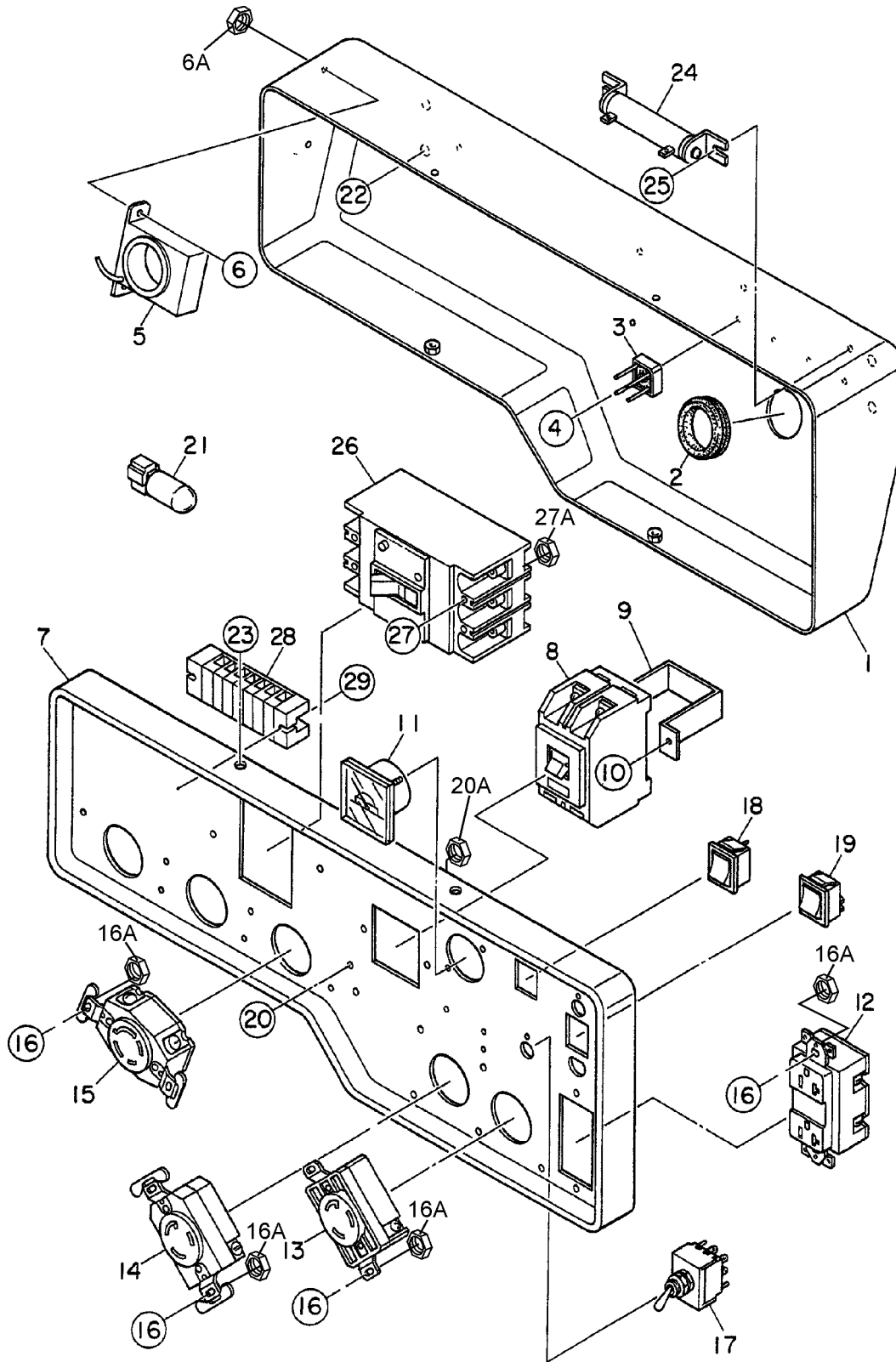

GDP-5H — CONTROL BOX ASSY.

CONTROL BOX ASSY.

<u>NO.</u>	<u>PART NO.</u>	<u>PART NAME</u>	<u>QTY.</u>	<u>REMARKS</u>
1	A3214000003	CONTROL BOX	1	
2	0601851755	GROMMET	1	C-30-NG-79-R
3	0601823204	RECTIFIER	4	S5VB60
4	0027103012	MACHINE SCREW	4	
5	0601823853	SLOW DOWN UNIT	1	
6	0027104010	MACHINE SCREW	2	
6	0030004000	NUT HEX	2	REPLACESP/N 0207004000
7	A4224000003	CONTROL PANEL	1	
8	0601802651	CIRCUIT BREAKER	1	KM-2 15A
9	4341817004	BRACKET CIRCUIT BREAKER	1	
10	0021004010	MACHINE SCREW	2	
11	0601806819	AC VOLTMETER	1	DE450-011 0~120/240V
12	0601812598	RECEPTACLE	1	5-20R
13	0601811035	RECEPTACLE	1	L5-30R
14	0601811032	RECEPTACLE	1	L60-20R
15	0601812594	RECEPTACLE	3	7410B
16	0021004010	MACHINE SCREW	12	
16A	0030004000	NUT HEX	12	REPLACESP/N 0207004000
17	0601830737	FULL POWER SWITCH	1	ET-330D12
18	0601831620	IDLE CONTROL SWITCH	1	C1550WA
19	0601831620	OPERATION SWITCH	1	C1550WA
20	0021004015	MACHINE SCREW	1	
20A	0030004000	NUT HEX	1	REPLACESP/N 0207004000
21	A3262800004	CAPACITOR ASSY.	1	VR1H102MHA 50V 1000 F
22	0017106016	HEX HEAD BOLT	4	
23	0017105010	HEX HEAD BOLT	4	
24	0601842415	RESISTOR, 7 OHM	1	
25	0027104010	MACHINE SCREW	2	
26	0601807480	CIRCUIT BREAKER, 12 AMPS	1	
27	0027104070	MACHINE SCREW	2	
27A	0030004000	NUT HEX	2	REPLACESP/N 0207004000
28	0601815465	TERMINAL BOARD	1	
29	0027104020	MACHINE SCREW	2	

GDP-5H — MUFFLER ASSY.

MUFFLER ASSY.

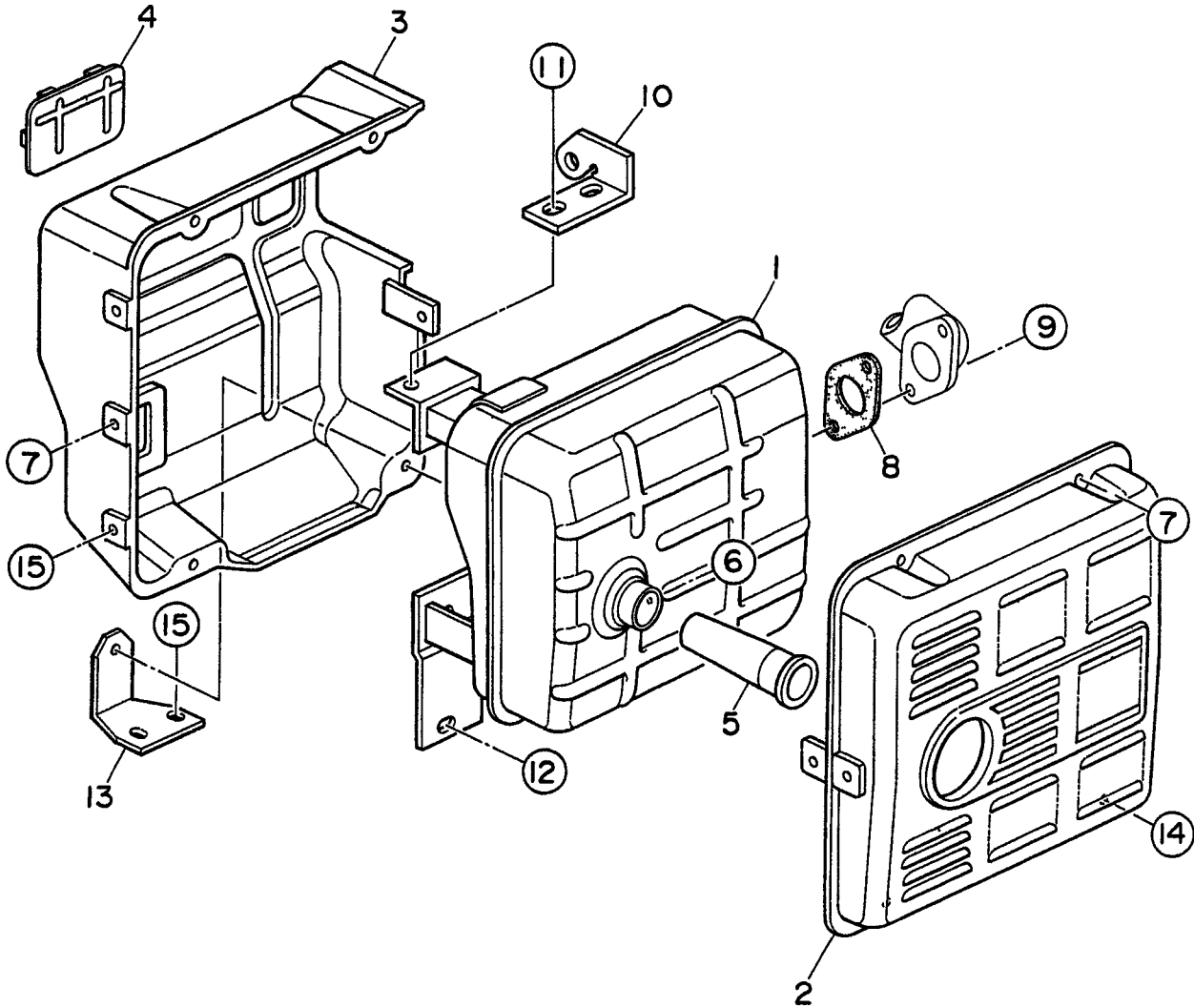

MUFFLER ASSY.

<u>NO</u>	<u>PART NO</u>	<u>PART NAME</u>	<u>QTY.</u>	<u>REMARKS</u>
1	7852310003	MUFFLER	1	
2	18320ZC2000	PROTECTOR	1	REPLACES P/N 0602302001
3	18325ZB4000	PROTECTOR	1	REPLACES P/N 0602302002
4	18329ZB4000	SEAL	2	REPLACES P/N 0602302003
5	18355ZB4630	ARRESTOR, SPARK	1	REPLACES P/N 0602313060
6	0602322060	TAPPING SCREW	1	REPLACES P/N 90183671003
7	0105050616	BOLT HEX HEAD	5	REPLACES P/N 0017106012
8	18333ZB4800	GASKET	1	REPLACES P/N 0602320175
9	0602322061	HEX HEAD BOLT	2	REPLACES P/N 957000802000
10	7855469004	BRACKET	1	
11	011008020	BOLT HEX HEAD	1	REPLACES 0017108020
12	011008020	BOLT HEX HEAD	1	REPLACES 0017108020
13	7905469004	BRACKET	1	
14	011206020	BOLT HEX HEAD	1	REPLACES 0017106020
15	0105050616	BOLT HEX HEAD	4	REPLACES 0017106012

GDP-5H — PIPE FRAME ASSY.

PIPE FRAME ASSY.

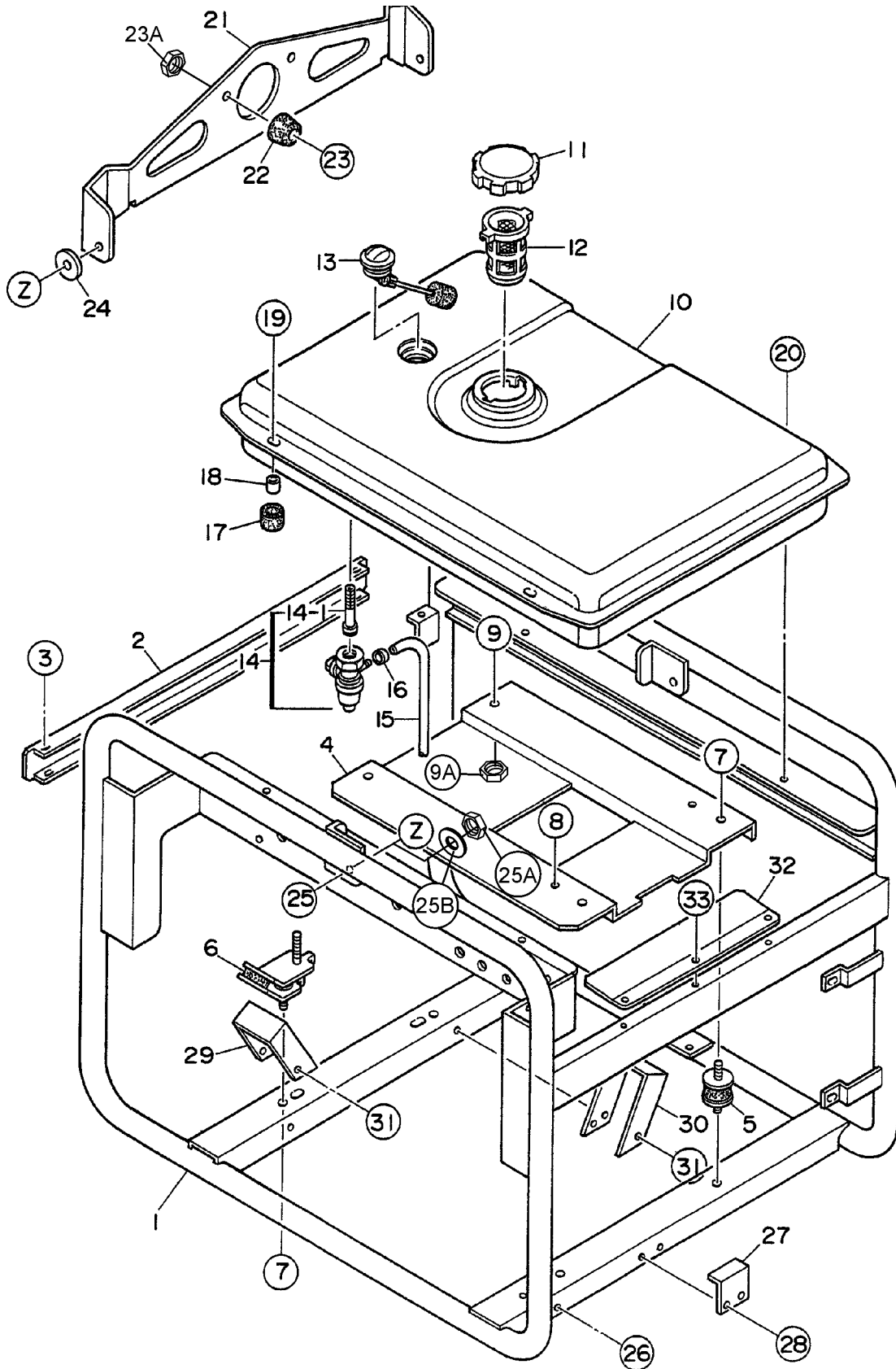

PIPE FRAME ASSY.

<u>NO.</u>	<u>PART NO.</u>	<u>PART NAME</u>	<u>QTY.</u>	<u>REMARKS</u>
1	A4417000102	PIPE FRAME	1	
2	A3417100004	BRACKET	1	
3	0017106016	HEX HEAD BOLT	4	
4	7855411203	BASE	1	
5	3015419604	RUBBER SUSPENSION	2	
6	1665419004	RUBBER SUSPENSION	2	REPLACES P/N 1725419214
7	020108060	NUT HEX	8	REPLACES P/N 0207008000
8	011208030	BOLT HEX HEAD	2	REPLACES P/N 0017108030
9	0017108040	HEX HEAD BOLT	2	
9A	0207008000	HEX NUT	2	
10	7905512002	FUEL TANK	1	
11	A9924800014	CAP FUEL TANK	1	
12	A9924800004	FUEL FILTER	1	
13	0602125034	FUEL GAUGE	1	
14	16950ZB4015	FUEL STRAINER	1	REPLACES P/N 0605510068
14-1	16952ZB4005	SCREEN SET	1	REPLACES P/N 0605510069
15	950014521040	HOSE	1	REPLACES P/N 0605513146
16	9500202080	HOSE BAND	2	REPLACES P/N 0605515178
17	7855525514	RUBBER CUSHION	2	
18	7855525604	COLLAR	2	
19	011208030	BOLT HEX HEAD	2	REPLACES P/N 0017108030
20	011208030	BOLT HEX HEAD	2	REPLACES P/N 0017108020
21	A9117200103	HANGER	1	
22	0601850097	STOPPER	1	
23	0021008025	MACHINE SCREW	1	
23A	0207008000	HEX NUT	1	
24	A9311100004	PLASTIC WASHER	2	
25	0011308025	HEX HEAD BOLT	2	
25A	0037908000	HEX NUT	2	
25B	0042108000	PLAIN WASHER	2	
26	0019206016	HEX HEAD BOLT	1	
27	7915456004	STOPPER	1	
28	0017106016	HEX HEAD BOLT	2	
29	7915455103	COVER	1	
30	7855455003	COVER	1	
31	0017106016	HEX HEAD BOLT	6	
32	A4484400004	COVER	1	
33	0017106016	HEX HEAD BOLT	3	

HONDA GX340K1EDN2 ENGINE — AIR CLEANER ASSY.

AIR CLEANER ASSY.

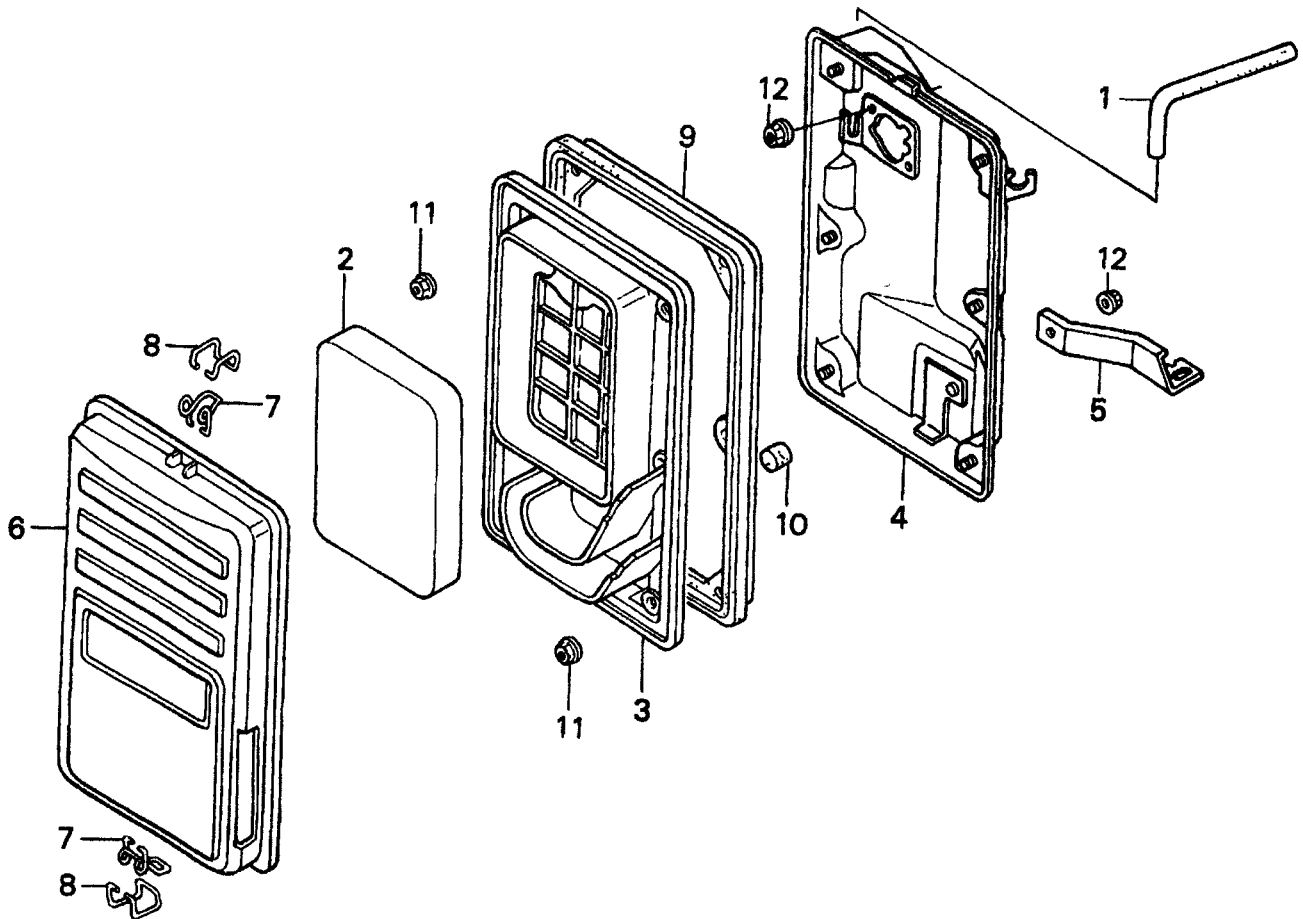

HONDA GX340K1EDN2 ENGINE — AIR CLEANER ASSY.

AIR CLEANER ASSY.

<u>NO.</u>	<u>PART NO.</u>	<u>PART NAME</u>	<u>QTY.</u>	<u>REMARKS</u>
1	15721ZB4000	TUBE BREATHER	1	
2	17211899000	ELEMENT, AIR CLEANER	1	
3	17212ZB4003	SEPARATOR, AIR CLEANER	1	
4	17220ZB4003	HOUSING, AIR CLEANER	1	
5	17222ZC2000	STAY, AIR CLEANER	1	
6	17231899000	COVER, AIR CLEANER	1	
7	17235899000	CLIP A, AIR CLEANER WIRE	2	
8	17236899000	CLIP B, AIR CLEANER WIRE	2	
9	17252899000	SEAL, AIR CLEANER	1	
10	17367413690	FILTER, DRAIN TUBE	1	
11	9405005000	NUT, FLANGE (5MM)	6	
12	9405006000	NUT, FLANGE (6MM)	3	

HONDA GX340K1EDN2 ENGINE — CAMSHAFT ASSY.

CAMSHAFT ASSY.

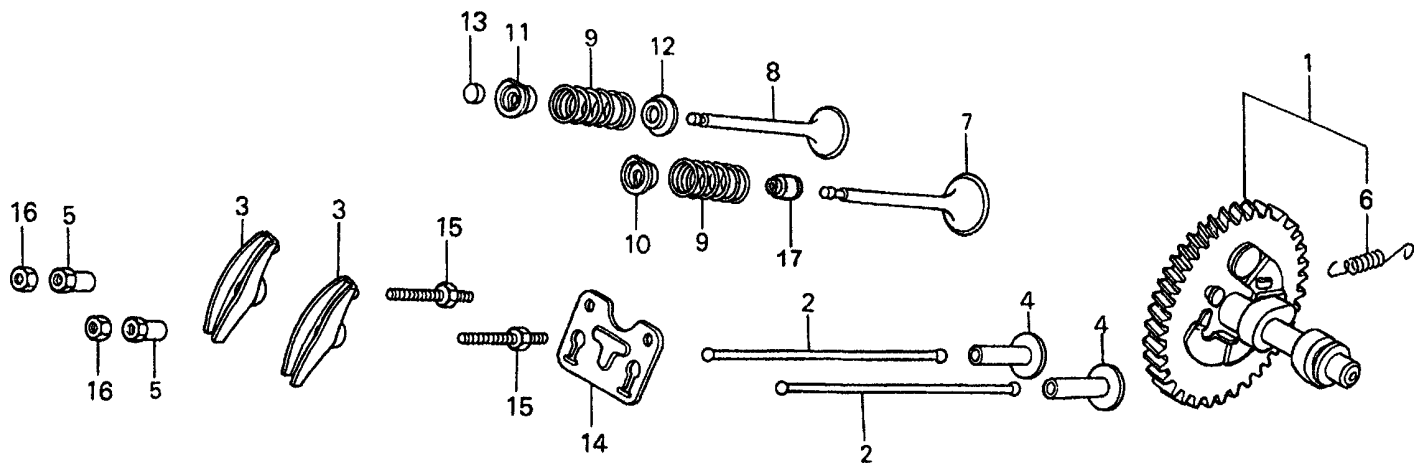

HONDA GX340K1EDN2 ENGINE — CAMSHAFT ASSY.

CAMSHAFT ASSY.

<u>NO.</u>	<u>PART NO.</u>	<u>PART NAME</u>	<u>QTY.</u>	<u>REMARKS</u>
1	14100ZE3020	CAMSHAFT ASSY.	1	INCLUDES ITEMS/W*
2	14410ZE3013	ROD, PUSH	2	
3	14431ZE2000	ARM, VALVE ROCKER	2	
3	14431ZE2010	ARM, VALVE ROCKER	2	
4	14441ZE2000	LIFTER, VALVE	2	
5	14451ZE1013	PIVOT, ROCKER ARM	2	
6*	14568ZE1000	SPRING, WEIGHT RETURN	1	
7	14711ZE3000	VALVE, IN.	1	
8	14721ZE3000	VALVE, EX.	1	
9	14751ZE2003	SPRING, VALVE	2	
10	14771ZE2000	RETAINER, IN. VALVE SPRING	1	
11	14773ZE2000	RETAINER, EX. VALVE SPRING	1	
12	14775ZE2010	SEAT, VALVE SPRING	1	
13	14781ZE2000	ROTATOR, VALVE	1	
14	14791ZE2010	PLATE, PUSH ROD GUIDE	1	
15	90012ZE0010	BOLT, PIVOT (8MM)	2	
16	90206ZE1000	NUT, PIVOT ADJ.	2	

HONDA GX340K1EDN2 ENGINE — CARBURETOR ASSY.

CARBURETOR ASSY.

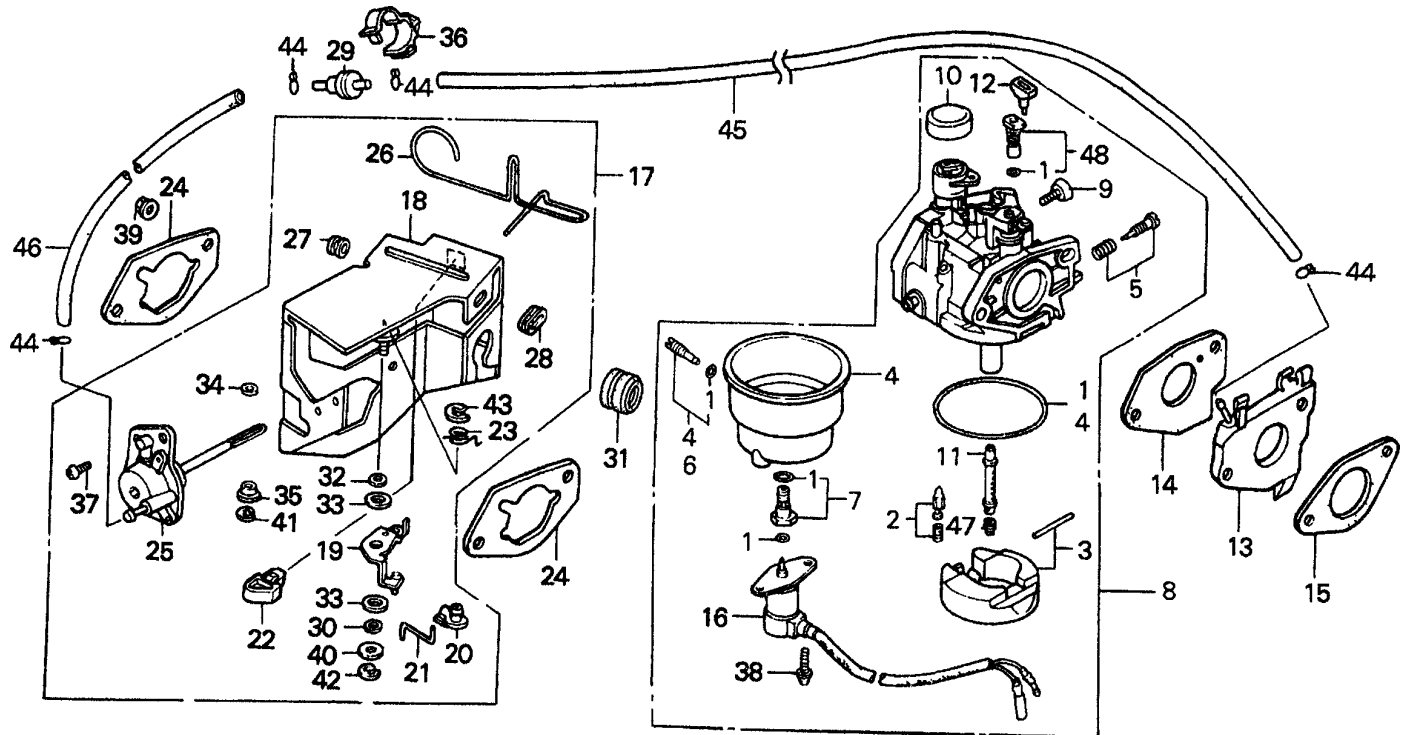

HONDA GX340K1EDN2 ENGINE — CARBURETOR ASSY.

CARBURETOR ASSY.

<u>NO.</u>	<u>PART NO.</u>	<u>PART NAME</u>	<u>QTY.</u>	<u>REMARKS</u>
1*	16010ZE3701	GASKET SET	1	
2*	16011ZA0931	VALVE SET, FLOAT	1	
3*	16013ZA0931	FLOAT SET	1	
4*	16015ZA0931	CHAMBER SET, FLOAT	1	
5*	16016ZH7W01	SCREW SET	1	
6	16024124760	SCREW SET, DRAIN	1	
7*	16028ZA0931	SCREW SET B	1	
8	16100ZE3F11	CARBURETOR ASSY. (BE82B B)	1	INCLUDES ITEMS W/*
9*	16124ZE0005	SCREW, THROTTLE STOP	1	
10*	16148141881	CAP, CHOKE LEVER DUST	1	
11*	16166ZE3F10	NOZZLE, MAIN	1	
12*	16172ZE3W10	COLLAR, SET	1	
13	16211ZE3700	INSULATOR, CARBURETOR	1	
14	16221ZE3800	GASKET, CARBURETOR	1	
15	16223ZE3800	GASKET, INSULATOR	1	
16*	16230ZE3701	VALVE ASSY., SOLENOID	1	
17	16260ZE2722	STAY ASSY., MANUAL CHOKE	1	INCLUDES ITEMS W/#
18#	16261ZE2702	STAY, SOLENOID	1	
19#	16262ZE2711	LEVER, CHOKE	1	
20#	16263ZA0000	JOINT, ROD	1	
21#	16264ZE2701	ROD, CHOKE	1	
22#	16265ZE2721	STOPPER, CHOKE ROD	1	
23#	16268ZE2721	SPRING, MANUAL CHOKE	1	
24	16269ZA0800	GASKET, AIR CLEANER	2	
25#	16400ZE2703	DIAPHRAGM ASSY.	1	
26#	16611ZE2711	ROD, CHOKE CONTROL	1	
27#	16613893000	GROMMET, CHOKE ROD	1	
28#	16615893000	GUIDE, CHOKE ROD	1	
29	36135ZF6D41	VALVE, DASHPOT CHECK	1	
30#	53149964003	BUSH, ARM PIVOT	1	
31	88911MJ3000	GROMMET, FENDER	1	
32#	90431ZE2700	WASHER, CHOKE LEVER	1	
33#	90432ZE2700	SEAL, CHOKE LEVER	2	
34#	90433ZE2700	WASHER, THRUST (2.7X8)	1	
35#	90434ZE2700	COLLAR, LEVER	1	
36	90650SD9003	CLIP, WIRE HARNESS	1	
37#	93500050120A	SCREW, PAN (5X12)	2	
38	938920501208	SCREW, WASHER (5X12)	2	
39	9405006000	NUT, FLANGE (6MM)	2	
40#	9410305000	WASHER, PLAIN (5MM)	1	
41#	9454002010	E-RING (2MM)	1	
42#	9454004010	E-RING (4MM)	1	
43#	9454007010	E-RING (7MM)	1	
44	9500202070	CLIP, TUBE (B7)	4	
45	950053500810M	BULK HOSE, VACUUM (3.5X8000) (3.5X75)	1	
46	950053500810M	BULK HOSE, VACUUM (3.5X8000) (3.5X130)	1	
47*	99101ZH80950	JET, MAIN (#95) (OPTIONAL)	1	
47*	99101ZH80980	JET, MAIN (#98) (OPTIONAL)	1	
47*	99101ZH81000	JET, MAIN (#100)	1	
48*	99204ZE00350	JET SET, PILOT (#35)	1	

HONDA GX340K1EDN2 ENGINE — CONTROL ASSY.

CONTROL ASSY.

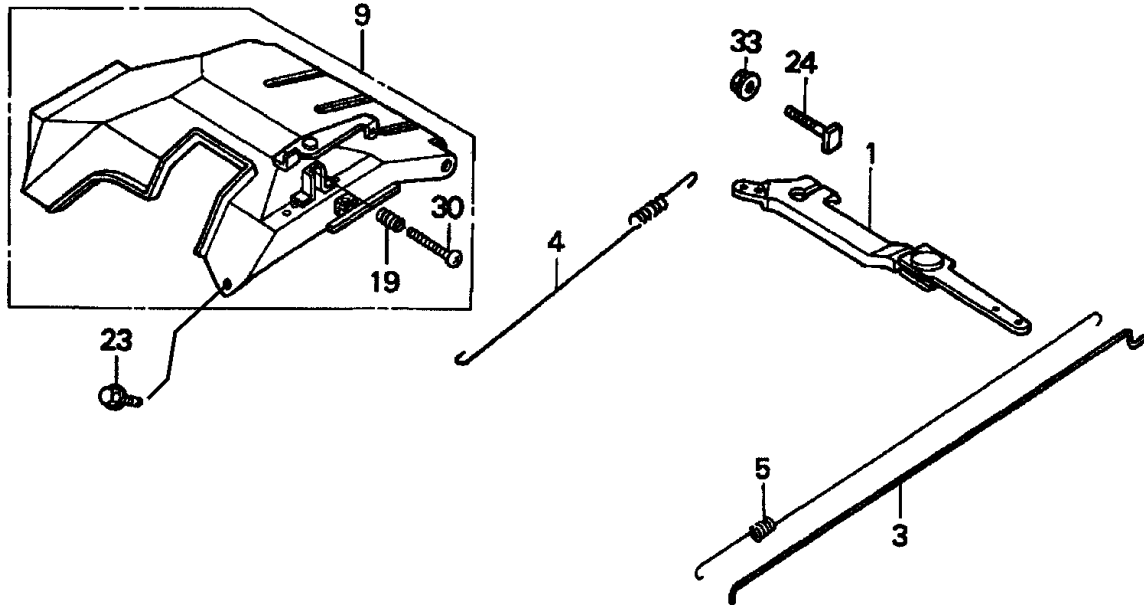

HONDA GX340K1EDN2 ENGINE — CONTROL ASSY.

CONTROL ASSY.

<u>NO.</u>	<u>PART NO.</u>	<u>PART NAME</u>	<u>QTY.</u>	<u>REMARKS</u>
1	16550ZE3700	ARM, GOVERNOR	1	
3	16555ZE3000	ROD, GOVERNOR	1	
4	16561ZE3000	SPRING, GOVERNOR	1	
5	16562ZE3700	SPRING, THROTTLE RETURN	1	
9	16570ZE3700	CONTROL ASSY.	1 ...	INCLUDES ITEMS W/*
19*	16584883300	SPRING, CONTROL ADJUSTING	1	
23	90013883000	BOLT, FLANGE (6X12) (CT200)	2	
24	90015ZE5010	BOLT, GOVERNOR ARM	1	
30*	93500050350A	SCREW, PAN (5X35)	1	
33	9405006000	NUT, FLANGE (6MM)	1	

HONDA GX340K1EDN2 ENGINE — CRANKCASE COVER ASSY.

CRANKCASE COVER ASSY.

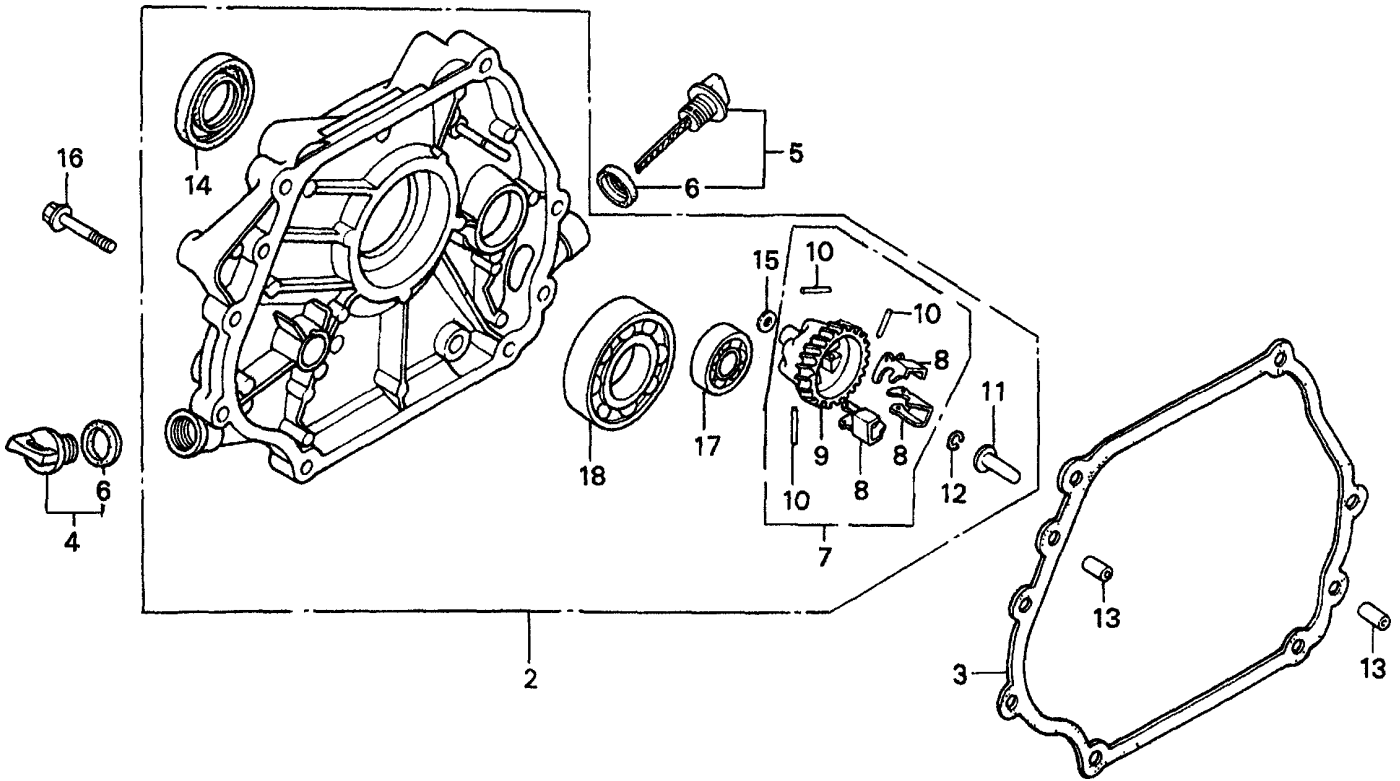

HONDA GX340K1EDN2 ENGINE — CRANKCASE COVER ASSY.

CRANKCASE COVER ASSY.

<u>NO.</u>	<u>PART NO.</u>	<u>PART NAME</u>	<u>QTY.</u>	<u>REMARKS</u>
2	11300ZE3020	COVER ASSY., CRANKCASE (S-TYPE)	1	INCLUDES ITEMS W/*
3	11381ZE3801	GASKET, CASE COVER	1	
4	15600ZG4003	CAP ASSY., OIL FILLER	1	
5	15600735003	CAP ASSY., OIL FILLER	1	
6	15625ZE1003	GASKET, OIL FILLER CAP	2	
7	16510ZE3000	GOVERNOR ASSY.	1	INCLUDES ITEMS W/#
8#	16511ZE8000	WEIGHT, GOVERNOR	3	
9#	16512ZE3000	HOLDER, GOVERNOR WEIGHT	1	
10#	16513ZE2000	PIN, GOVERNOR WEIGHT	3	
11	16531ZE2000	SLIDER, GOVERNOR	1	
12	90602ZE1000	CLIP, GOVERNOR HOLDER	1	
13	90701HC4000	PIN, DOWEL (8X12)	2	
14*	92102ZE3004	OIL SEAL (35X52X8)	1	
15#	9410106800	WASHER, PLAIN (6MM)	1	
16	957010804000	BOLT, FLANGE (8X40)	7	
17*	961006202000	BEARING, RADIAL BALL (6202)	1	
18*	961006207000	BEARING, RADIAL BALL (6207)	1	

HONDA GX340K1EDN2 ENGINE — CRANKSHAFT ASSY.

CRANKSHAFT ASSY.

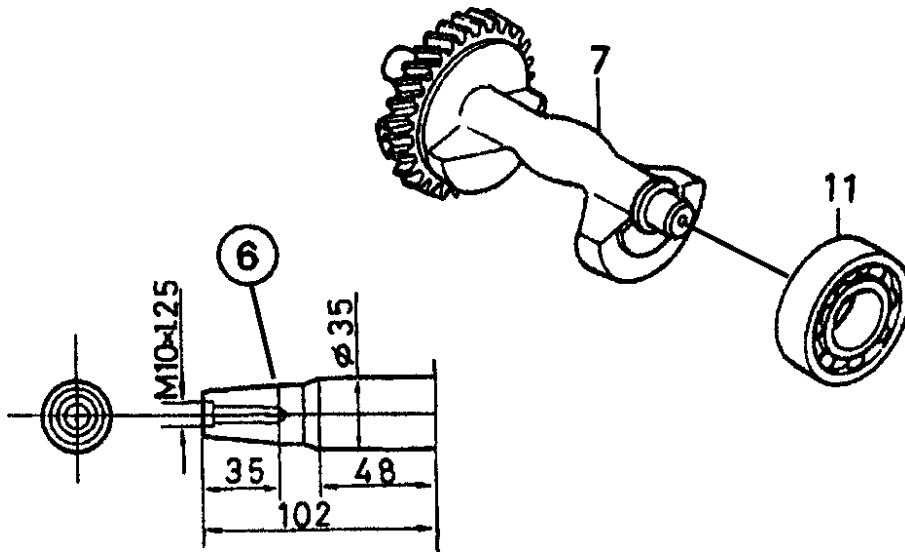

HONDA GX340K1EDN2 ENGINE — CRANKSHAFT ASSY.

CRANKSHAFT ASSY.

<u>NO.</u>	<u>PART NO.</u>	<u>PART NAME</u>	<u>QTY.</u>	<u>REMARKS</u>
6	13310ZE3701	CRANKSHAFT (E-TYPE)	1	
7	13351ZE3010	WEIGHT, BALANCER	1	
11	961006207000	BEARING, RADIAL BALL (6207)	1	

HONDA GX340K1EDN2 ENGINE — CYLINDER BARREL ASSY.

CYLINDER BARREL ASSY.

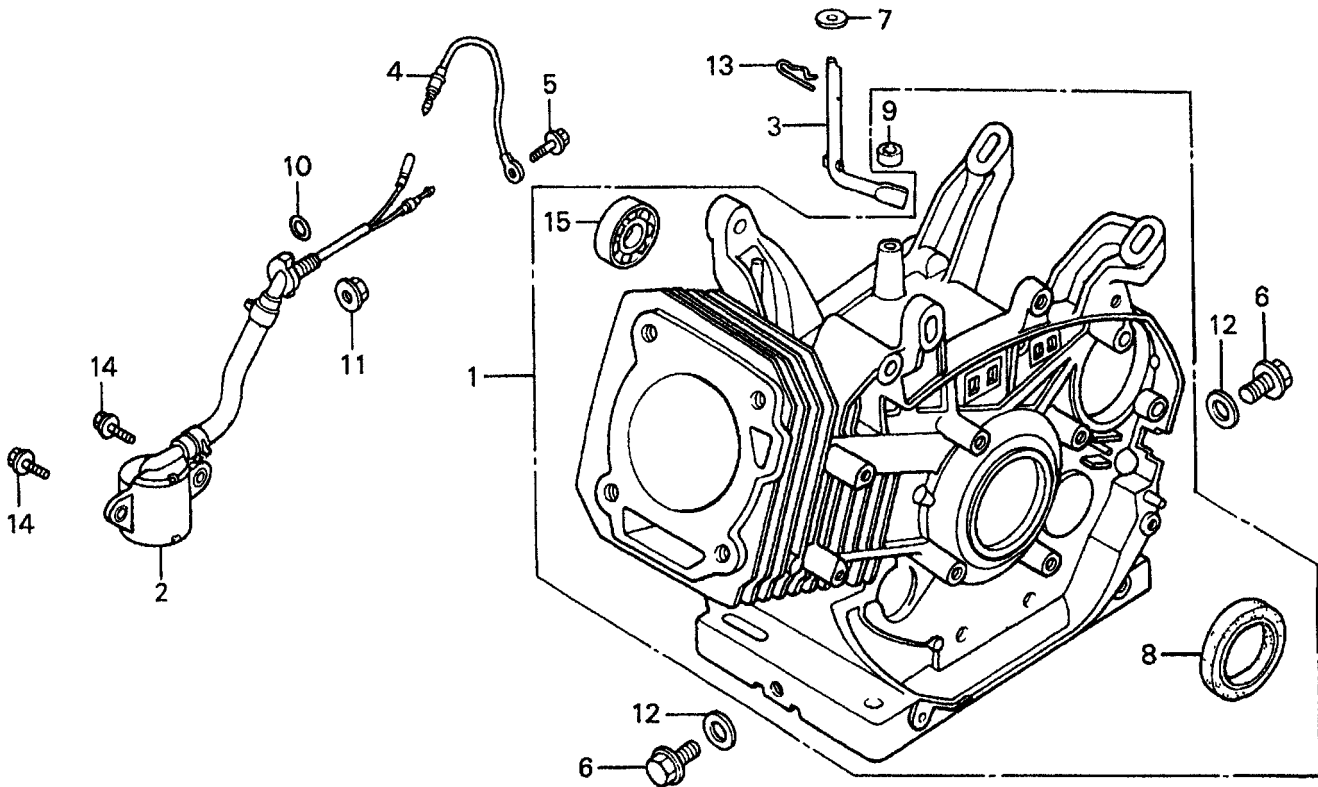

HONDA GX340K1EDN2 ENGINE — CYLINDER BARREL ASSY.

CYLINDER BARREL ASSY.

<u>NO.</u>	<u>PART NO.</u>	<u>PART NAME</u>	<u>QTY.</u>	<u>REMARKS</u>
1	12000ZE3817	CYLINDER ASSY. (ALERT)	1	INCLUDES ITEMS W/*
2	15510ZE2043	SWITCH ASSY., OIL LEVEL	1	
3	16541ZE3010	SHAFT, GOVERNOR ARM	1	
4	31161ZE2000	WIRE, GROUND	1	
5	90013883000	BOLT, FLANGE (6X12) (CT200)	1	
6	90131896650	BOLT, DRAIN PLUG	2	
7	90446KE1000	WASHER (8.2X17X0.8)	1	
8*	91201ZE3004	OIL SEAL (35X52X8)	1	
9*	91203952771	OIL SEAL (8X14X5)	1	
10	91353671003	O-RING (13.5X1.5) (ARAI)	1	
11	9405010000	NUT, FLANGE (10MM)	1	
12	9410912000	WASHER, DRAIN PLUG (12MM)	2	
13	9425110000	PIN, LOCK (10MM)	1	
14	957010601200	BOLT FLANGE (6X12)	2	
15*	961006202000	BEARING, RADIAL BALL (6202)	1	

HONDA GX340K1EDN2 ENGINE — CYLINDER HEAD ASSY.

CYLINDER HEAD ASSY.

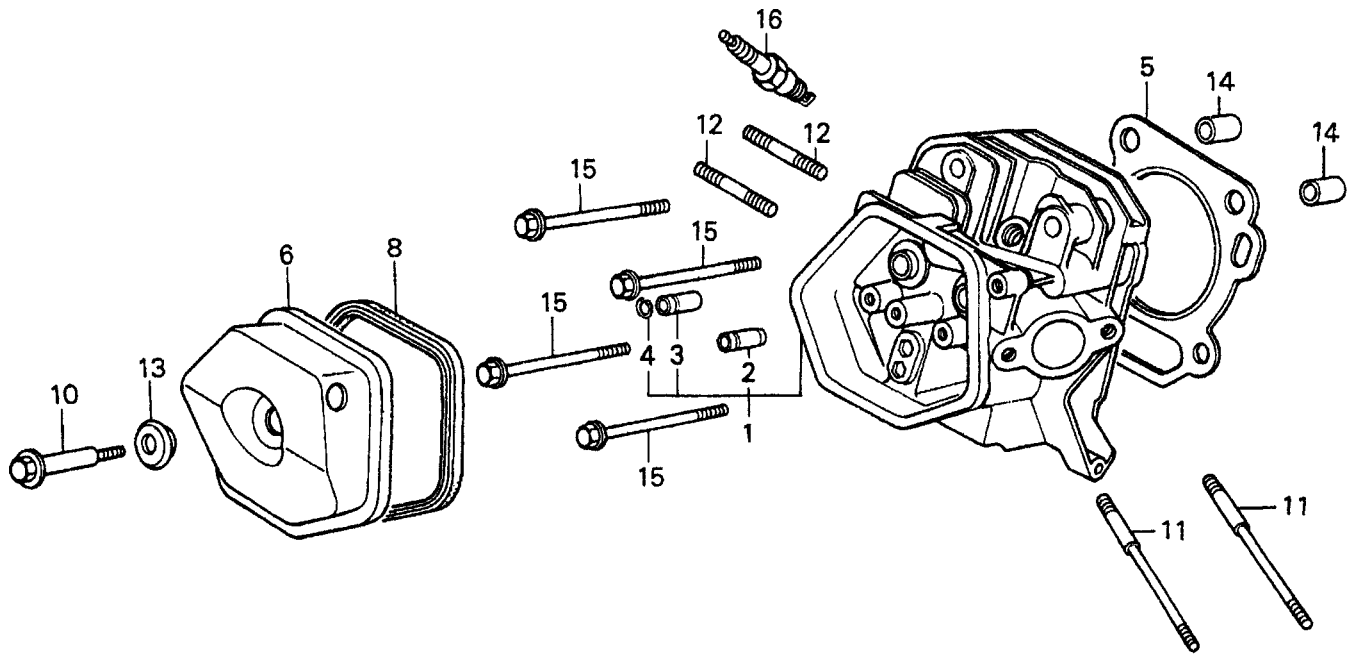

HONDA GX340K1EDN2 ENGINE — CYLINDER HEAD ASSY.

CYLINDER HEAD ASSY.

<u>NO.</u>	<u>PART NO.</u>	<u>PART NAME</u>	<u>QTY.</u>	<u>REMARKS</u>
1	12200ZF6W01	CYLINDER HEAD	1	
2	12204ZE2306	GUIDE, VALVE (OS) (OPTIONAL)	1	
3	12205ZE2305	GUIDE, EX. VALVE (OS) (OPTIONAL)	1	
4	12216ZE2300	CLIP, VALVE GUIDE	1	
5	12251ZE3W00	GASKET, CYLINDER HEAD	1	
6	12310ZE2020	COVER, HEAD	1	
8	12391ZE2020	GASKET, CYLINDER HEAD COVER	1	
10	90014ZE2000	BOLT, HEAD COVER	1	
11	90042ZE3700	BOLT, STUD (8X106)	2	
12	92900080320E	BOLT 2, STUD (8X32)	2	
13	90441ZE2010	WASHER, HEAD COVER	1	
14	9430112200	PIN A, DOWEL (12X20)	2	
15	957011008000	BOLT, FLANGE (10X80)	4	
16	9807955846	SPARK PLUG (BPR5ES) (NGK) (OPTIONAL)	1	
16	9807955855	SPARK PLUG (W16EPR-U) (DENSO)	1	

HONDA GX340K1EDN2 ENGINE — FAN COVER ASSY.

FAN COVER ASSY.

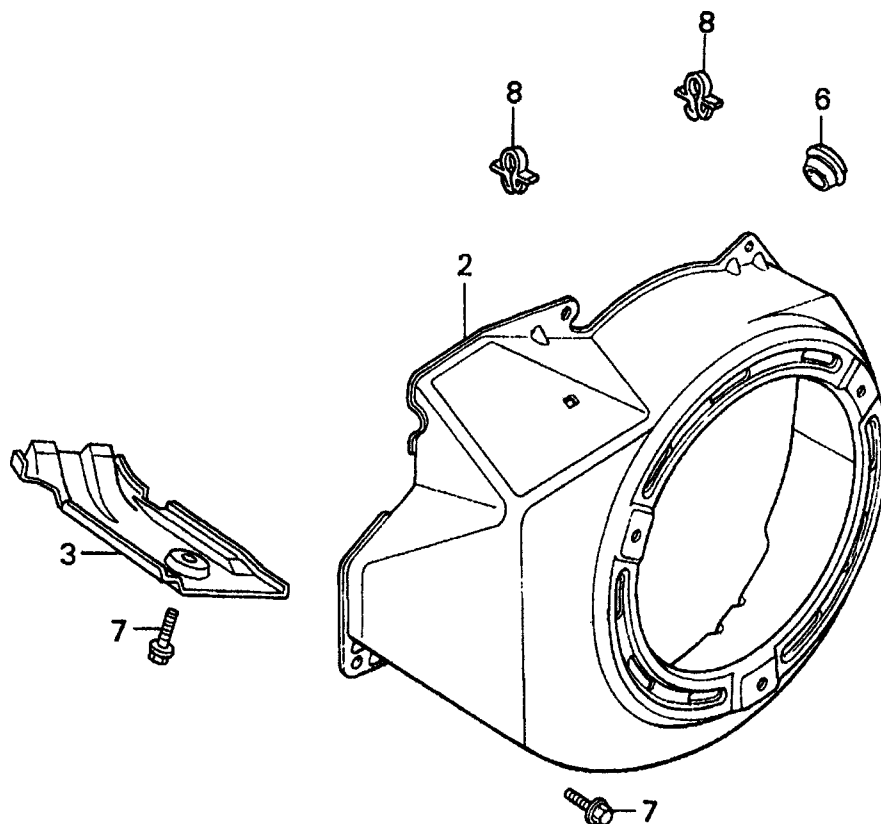

HONDA GX340K1EDN2 ENGINE — FAN COVER ASSY.

FAN COVER ASSY.

<u>NO.</u>	<u>PART NO.</u>	<u>PART NAME</u>	<u>QTY.</u>	<u>REMARKS</u>
2	19610ZE3700ZB	COVER, FAN *NH1* (BLACK)	1	
3	19631ZE3W00	SHROUD	1	
6	81329567020	GROMMET, DRAIN HOLE	1	
7	90013883000	BOLT, FLANGE (6X12) (CT200)	6	
8	90654SA4003	CLIP, WIRE HARNESS (6MM) (WHITE)	2	

HONDA GX340K1EDN2 ENGINE — FLYWHEEL ASSY.

FLYWHEEL ASSY.

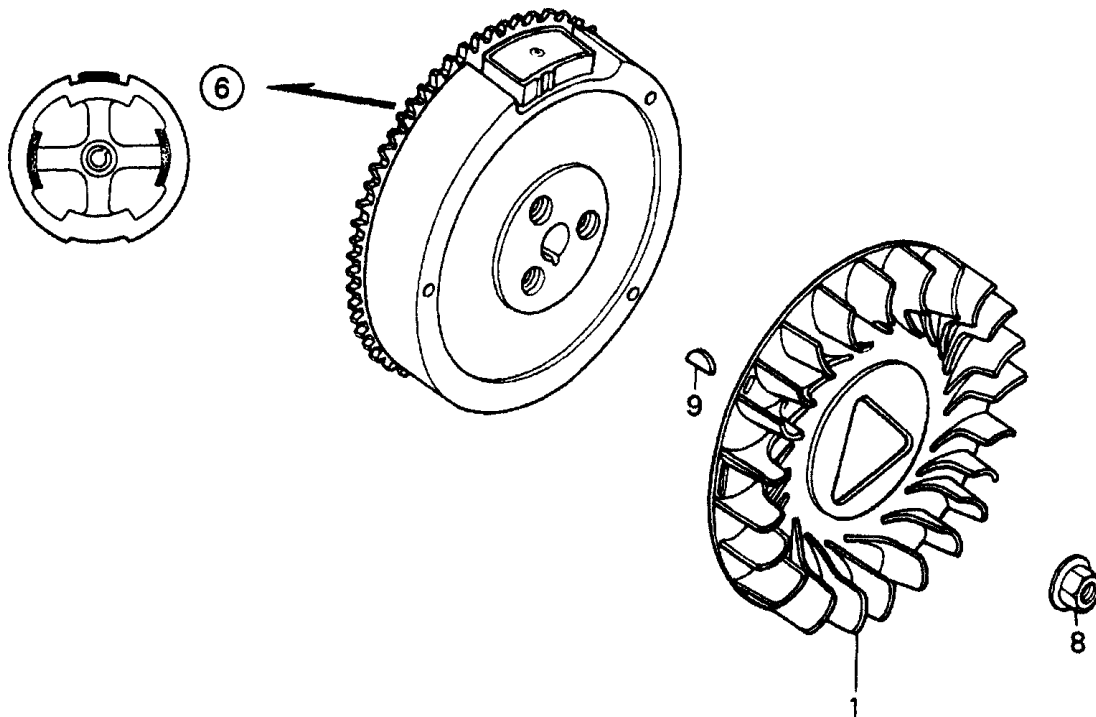

HONDA GX340K1EDN2 ENGINE — FLYWHEEL ASSY.

FLYWHEEL ASSY.

<u>NO.</u>	<u>PART NO.</u>	<u>PART NAME</u>	<u>QTY.</u>	<u>REMARKS</u>
1	19511ZE3000	FAN, COOLING	1	
6	31100ZE3712	FLYWHEEL, LAMP	1	
8	90201ZE3V00	NUT, SPECIAL 16MM	1	
9	90741ZE2000	KEY, SPECIAL WOODRUFF (25X18)	1	

HONDA GX340K1EDN2 ENGINE — IGNITION COIL ASSY.

IGNITION COIL ASSY.

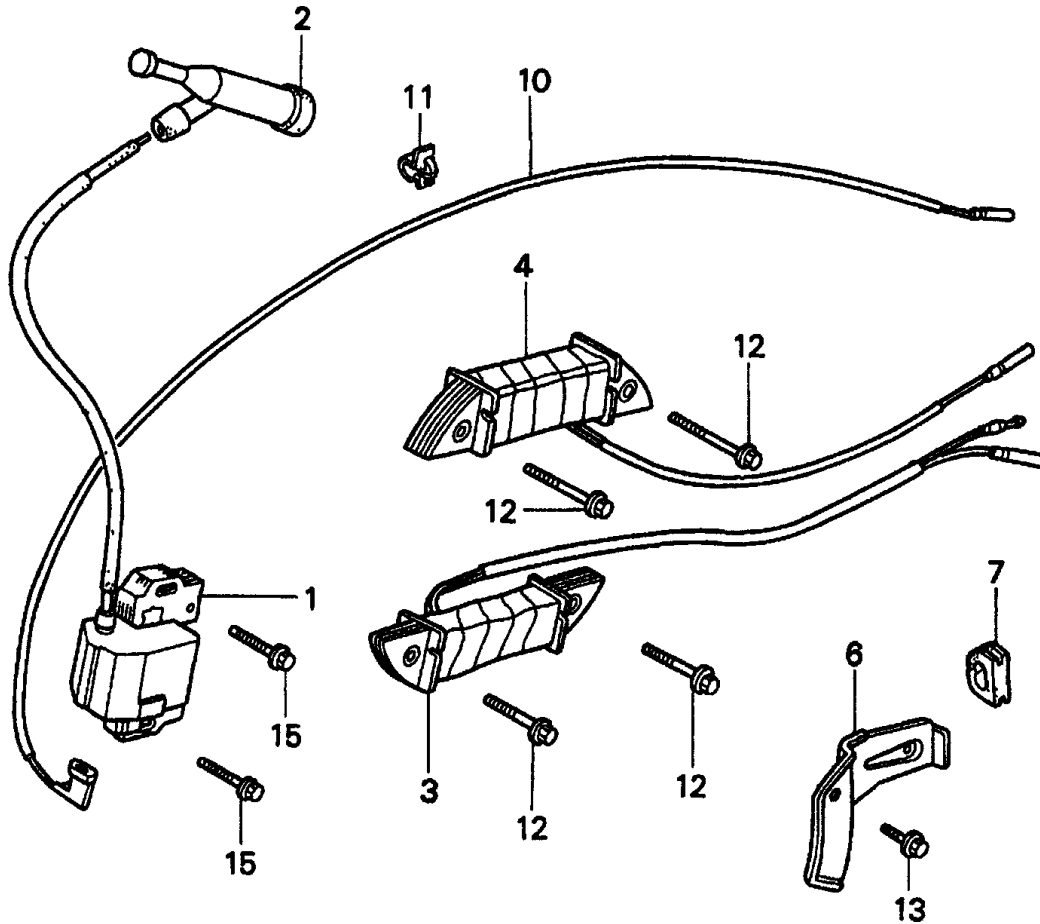

HONDA GX340K1EDN2 ENGINE — IGNITION COIL ASSY.

IGNITION COIL ASSY.

<u>NO.</u>	<u>PART NO.</u>	<u>PART NAME</u>	<u>QTY.</u>	<u>REMARKS</u>
1	30500ZE2023	COIL ASSY., IGNITION	1	
2	30700ZE1013	CAP ASSY., NOISE SUPPRESSOR	1	
3	31510ZE1811	COIL ASSY., LAMP (12V/25W)	1	
4	31510ZE3003	COIL ASSY., LAMP (12V/25W)	1	
6	31511ZE3000	CLAMP, WIRE	1	
7	31512ZE2000	GROMMET, WIRE	1	
10	36101ZE3800	WIRE, STOP SWITCH (470MM)	1	
11	36103ZE1000	HOLDER, STOP SWITCH WIRE	1	
12	90012888000	BOLT, FLANGE (6X40)	4	
13	90013883000	BOLT, FLANGE (6X12) (CT200)	1	
15	90015883000	BOOT, FLANGE (6X28)	2	

HONDA GX340K1EDN2 ENGINE — PISTON ASSY.

PISTON ASSY.

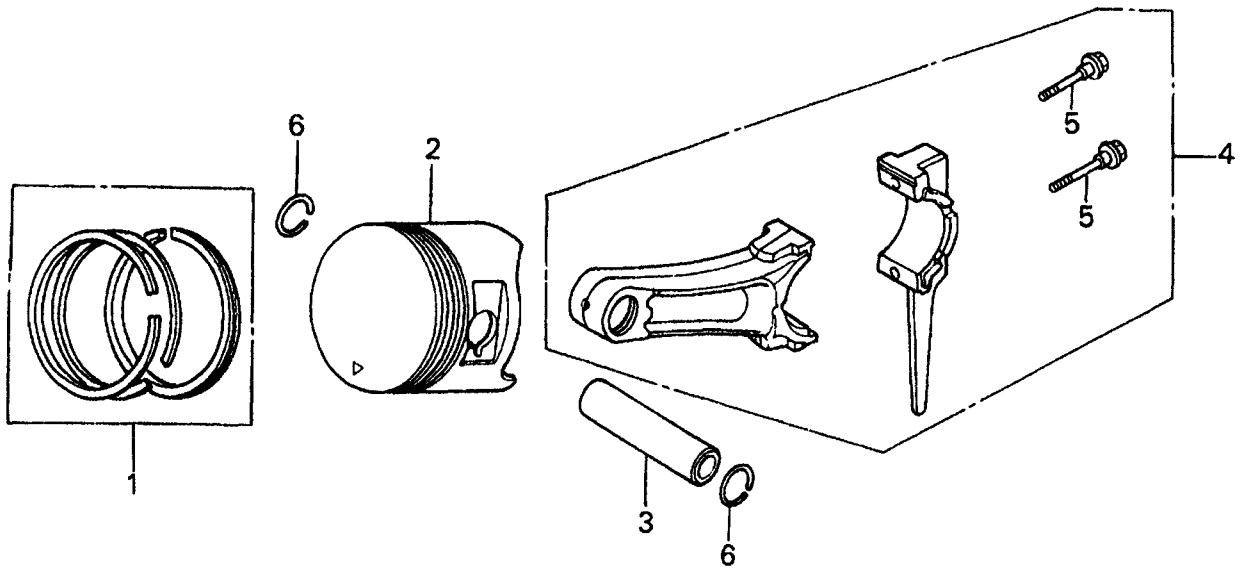

HONDA GX340K1EDN2 ENGINE — PISTON ASSY.

PISTON ASSY.

<u>NO.</u>	<u>PART NO.</u>	<u>PART NAME</u>	<u>QTY.</u>	<u>REMARKS</u>
1	13010ZE3003	RING SET, PISTON (STD)	1	
1	13011ZE3003	RING SET, PISTON (OS 0.25) (OPTIONAL)	1	
1	13012ZE3003	RING SET, PISTON (OS 0.50) (OPTIONAL)	1	
1	13013ZE3003	RING SET, PISTON (0.75) (OPTIONAL)	1	
2	13101ZE3W00	PISTON (STD)	1	
3	13111ZF6000	PIN, PISTON	1	
4	13200ZE3010	ROD ASSY., CONNECTING (STD)	1	
5	90001ZE8000	BOLT, CONNECTING ROD	2	
6	90601ZE3000	CLIP, PISTON PIN (20MM)	2	

HONDA GX340K1EDN2 ENGINE — RECOIL STARTER ASSY.

RECOIL STARTER ASSY.

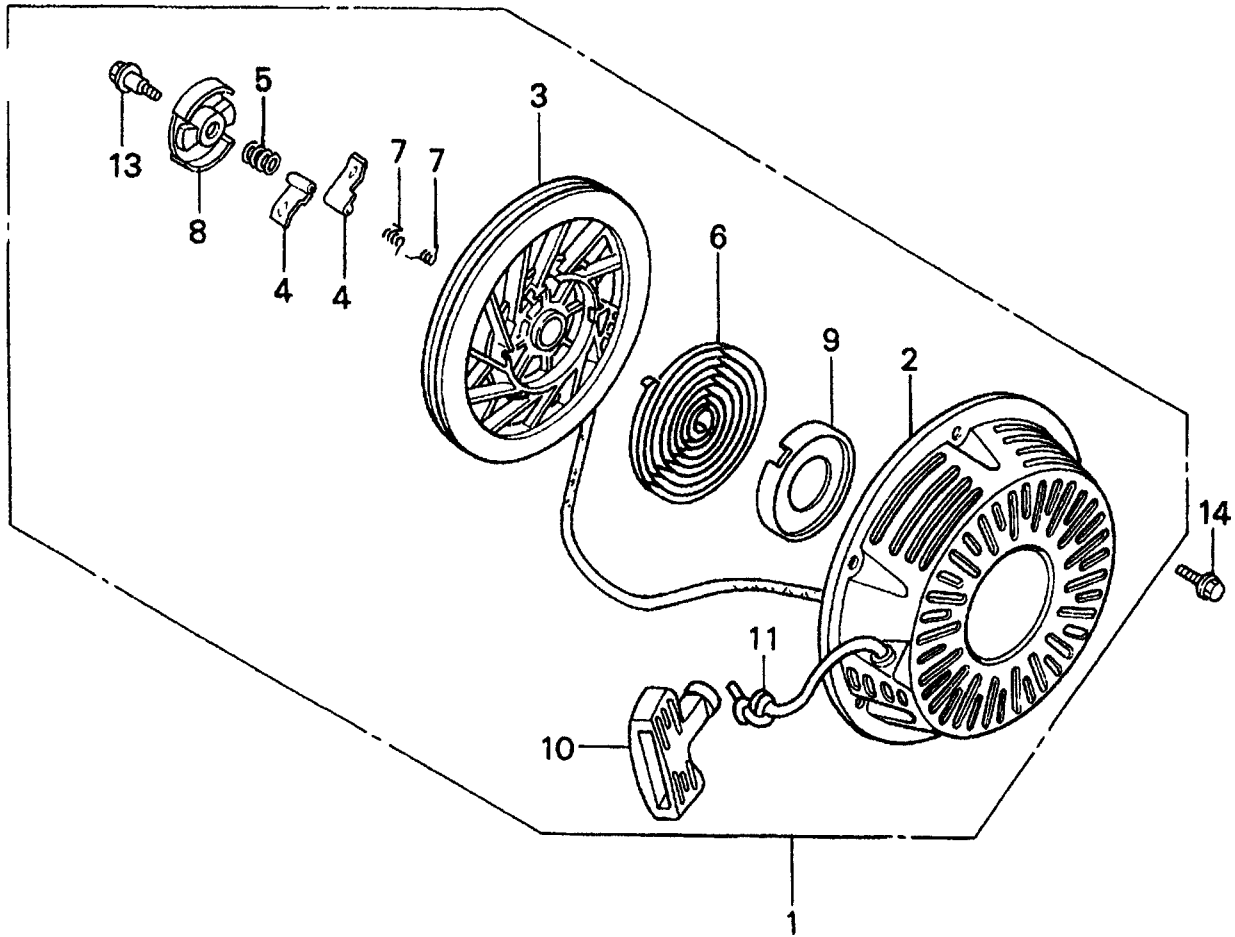

HONDA GX340K1EDN2 ENGINE — RECOIL STARTER ASSY.

RECOIL STARTER ASSY.

<u>NO.</u>	<u>PART NO.</u>	<u>PART NAME</u>	<u>QTY.</u>	<u>REMARKS</u>
	28400ZE3W01ZB	STARTER ASSY., RECOIL *NH1* (BLACK)	1	
2	28410ZE3W01ZB	CASE, RECOIL STARTER *NH1* (BLACK)	1	
3	28421ZE3W01	PULLEY, RECOIL STARTER	1	
4	28422ZE2W01	RATCHET, STARTER	2	
5	28441ZE2W01	SPRING, FRICTION	1	
6	28442ZE2W01	SPRING, STARTER RETURN	1	
7	28443ZE2W01	SPRING, RATCHET	2	
8	28444ZE2W01	RETAINER, SPRING	1	
9	28445ZE2W01	HOLDER, SPRING	1	
10	28461ZE2W02	GRIP, STARTER	1	
11	08560ZG92111	ROPE, RECOIL STARTER	1	REPLACES P/N 28462ZE3W01
13	90004ZE2W01	SCREW, CENTER	1	
14	90008ZE2003	BOLT, FLANGE (6X10)	3	

HONDA GX340K1EDN2 ENGINE — SOLENOID ASSY.

SOLENOID ASSY.

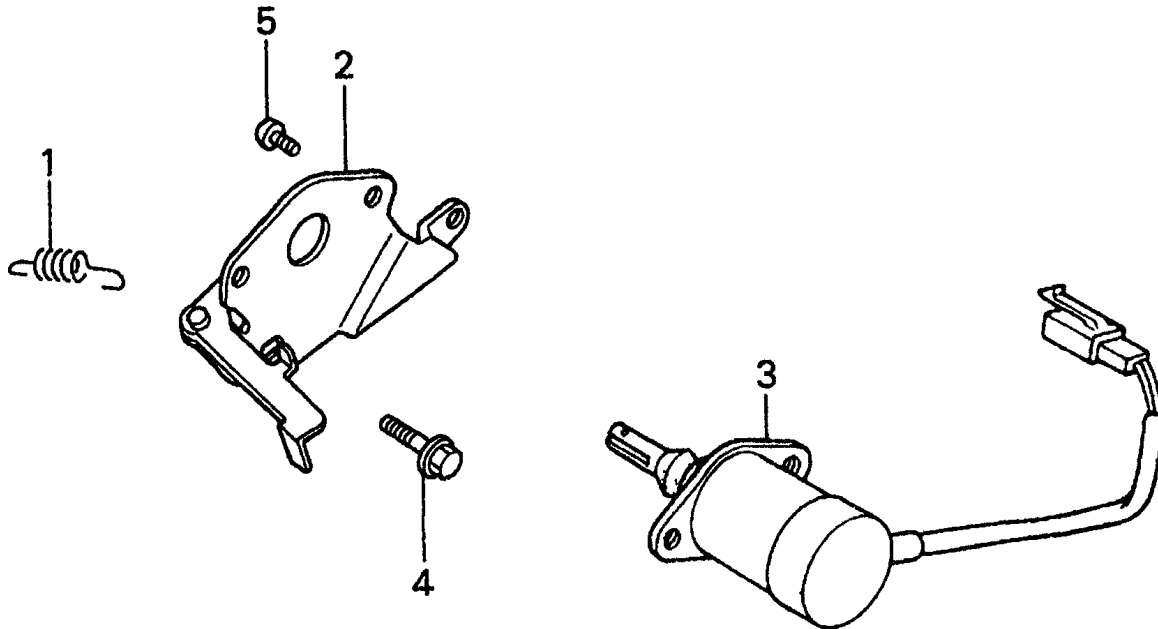

HONDA GX340K1EDN2 ENGINE — SOLENOID ASSY.

SOLENOID ASSY.

<u>NO.</u>	<u>PART NO.</u>	<u>PART NAME</u>	<u>QTY.</u>	<u>REMARKS</u>
1	16268893000	SPRING, CHOKE RETURN	1	
2	17850ZD1E30	LEVER, THROTTLE	1	
3	36160ZB4003	SOLENOID ASSY.	1	
4	90013883000	BOLT, FLANGE (6X12) (CT200)	1	
5	93500050080A	SCREW, PAN (5X8)	2	

HONDA GX340K1EDN2 ENGINE — LABELS ASSY.

LABELS ASSY.

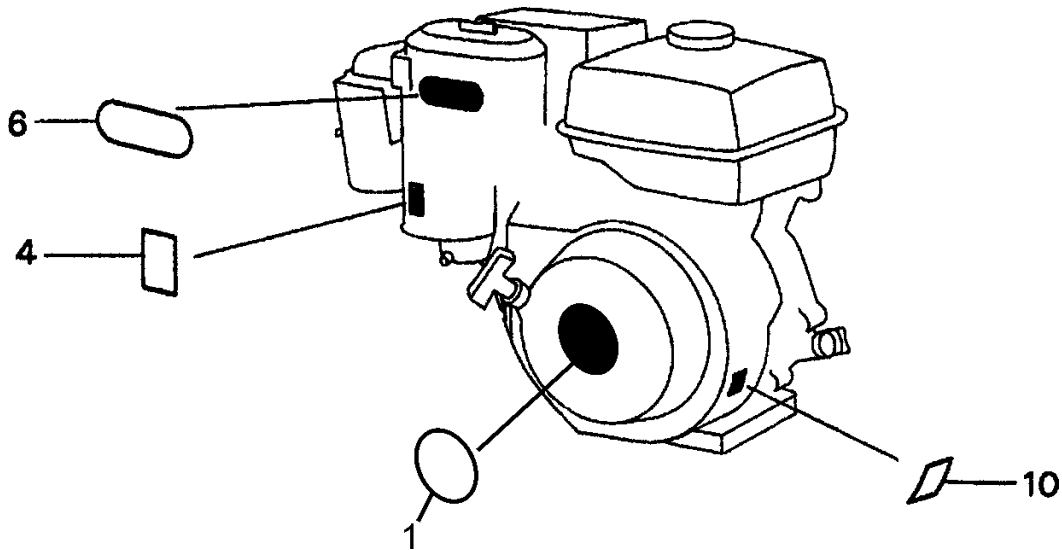

HONDA GX340K1EDN2 ENGINE — LABELS ASSY.

LABELS ASSY.

<u>NO.</u>	<u>PART NO.</u>	<u>PART NAME</u>	<u>QTY.</u>	<u>REMARKS</u>
1	87521ZE3W01	EMBLEM	1	
4	87528898620	MARK, CHOKE	1	
6	87533ZC0630	MARK, AIR CLEANER	1	
10	87594ZB4A00	MARK, OIL CAUTION	1	

PAYMENT TERMS

Terms of payment for parts are net 10 days.

FREIGHT POLICY

All parts orders will be shipped collect or prepaid with the charges added to the invoice. All shipments are F.O.B. point of origin. Multiquip's responsibility ceases when a signed manifest has been obtained from the carrier, and any claim for shortage or damage must be settled between the consignee and the carrier.

MINIMUM ORDER

The minimum charge for orders from Multiquip is \$15.00 net. Customers will be asked for instructions regarding handling of orders not meeting this requirement.

RETURNED GOODS POLICY

Return shipments will be accepted and credit will be allowed, subject to the following provisions:

1. A Returned Material Authorization must be approved by Multiquip prior to shipment.
2. To obtain a Return Material Authorization, a list must be provided to Multiquip Parts Sales that defines item numbers, quantities, and descriptions of the items to be returned.
 - a. The parts numbers and descriptions must match the current parts price list.
 - b. The list must be typed or computer generated.
 - c. The list must state the reason(s) for the return.
 - d. The list must reference the sales order(s) or invoice(s) under which the items were originally purchased.
 - e. The list must include the name and phone number of the person requesting the RMA.
3. A copy of the Return Material Authorization must accompany the return shipment.
4. Freight is at the sender's expense. All parts must be returned freight prepaid to Multiquip's designated receiving point.

5. Parts must be in new and resalable condition, in the original Multiquip package (if any), and with Multiquip part numbers clearly marked.
6. The following items are not returnable:
 - a. Obsolete parts. (If an item is in the price book and shows as being replaced by another item, it is obsolete.)
 - b. Any parts with a limited shelf life (such as gaskets, seals, "O" rings, and other rubber parts) that were purchased more than six months prior to the return date.
 - c. Any line item with an extended dealer net price of less than \$5.00.
 - d. Special order items.
 - e. Electrical components.
 - f. Paint, chemicals, and lubricants.
 - g. Decals and paper products.
 - h. Items purchased in kits.
7. The sender will be notified of any material received that is not acceptable.
8. Such material will be held for five working days from notification, pending instructions. If a reply is not received within five days, the material will be returned to the sender at his expense.
9. Credit on returned parts will be issued at dealer net price at time of the original purchase, less a 15% restocking charge.
10. In cases where an item is accepted, for which the original purchase document can not be determined, the price will be based on the list price that was effective twelve months prior to the RMA date.
11. Credit issued will be applied to future purchases only.

PRICING AND REBATES

Prices are subject to change without prior notice. Price changes are effective on a specific date and all orders received on or after that date will be billed at the revised price. Rebates for price declines and added charges for price increases will not be made for stock on hand at the time of any price change.

Multiquip reserves the right to quote and sell direct to Government agencies, and to Original Equipment Manufacturer accounts who use our products as integral parts of their own products.

SPECIAL EXPEDITING SERVICE

A \$35.00 surcharge will be added to the invoice for special handling including bus shipments, insured parcel post or in cases where Multiquip must personally deliver the parts to the carrier.

LIMITATIONS OF SELLER'S LIABILITY

Multiquip shall not be liable hereunder for damages in excess of the purchase price of the item with respect to which damages are claimed, and in no event shall Multiquip be liable for loss of profit or good will or for any other special, consequential or incidental damages.

LIMITATION OF WARRANTIES

No warranties, express or implied, are made in connection with the sale of parts or trade accessories nor as to any engine not manufactured by Multiquip. Such warranties made in connection with the sale of new, complete units are made exclusively by a statement of warranty packaged with such units, and Multiquip neither assumes nor authorizes any person to assume for it any other obligation or liability whatever in connection with the sale of its products. Apart from such written statement of warranty, there are no warranties, express, implied or statutory, which extend beyond the description of the products on the face hereof.

OPERATION AND PARTS MANUAL

HERE'S HOW TO GET HELP

PLEASE HAVE THE MODEL AND SERIAL
NUMBER *ON-HAND* WHEN CALLING

MULTIQUIP CORPORATE OFFICE

18910 Wilmington Ave.
Carson, CA 90746
Email: mq@multiquip.com
Internet: www.multiquip.com

800-421-1244
FAX: 310-537-3927

PARTS DEPARTMENT

800-427-1244
310-537-3700

FAX: 800-672-7877
FAX: 310-637-3284

MAYCO PARTS

800-306-2926
310-537-3700

FAX: 800-672-7877
FAX: 310-637-3284

SERVICE DEPARTMENT

800-421-1244
310-537-3700

FAX: 310-537-4259

TECHNICAL ASSISTANCE

800-478-1244

FAX: 310-631-5032

WARRANTY DEPARTMENT

800-421-1244, EXT.279
310-537-3700, EXT.279

FAX: 310-537-1173

Your Local Dealer is:



MULTIQUIP INC.

18910 WILMINGTON AVE.
CARSON, CALIFORNIA 90746
800-421-1244 • 310-537-3700
FAX: 310-537-3927
E-mail: mq@multiquip.com
Internet: multiquip.com

Free Manuals Download Website

<http://myh66.com>

<http://usermanuals.us>

<http://www.somanuals.com>

<http://www.4manuals.cc>

<http://www.manual-lib.com>

<http://www.404manual.com>

<http://www.luxmanual.com>

<http://aubethermostatmanual.com>

Golf course search by state

<http://golfingnear.com>

Email search by domain

<http://emailbydomain.com>

Auto manuals search

<http://auto.somanuals.com>

TV manuals search

<http://tv.somanuals.com>