

# PARTS AND OPERATION MANUAL



## B-Series Power Trowel (CHINA)

© COPYRIGHT 2001, MULTIQUIP INC.

Revision #0 (12/03/01)



**MULTIQUIP INC.**

18910 WILMINGTON AVE.  
CARSON, CALIFORNIA 90746  
310-537-3700  
800-421-1244  
FAX: 310-537-3927

**PARTS DEPARTMENT:**

800-427-1244  
FAX: 800-672-7877

**SERVICE DEPARTMENT:**

800-478-1244  
FAX: 310-537-4259

**E-mail: [mq@multiquip.com](mailto:mq@multiquip.com) • [www.multiquip.com](http://www.multiquip.com)**

Atlanta • Boise • Dallas • Houston • Newark  
Montreal, Canada • Manchester, UK  
Rio De Janeiro, Brazil • Guadalajara, Mexico

P/N 20966

## **HERE'S HOW TO GET HELP**

*PLEASE HAVE THE MODEL AND SERIAL NUMBER  
ON-HAND WHEN CALLING*

### ***PARTS DEPARTMENT***

*800-427-1244 or 310-537-3700*

*FAX: 800-672-7877 or 310-637-3284*

### ***SERVICE DEPARTMENT/TECHNICAL ASSISTANCE***

*800-478-1244 or 310-537-3700*

*FAX: 310- 537-4259*

### ***WARRANTY DEPARTMENT***

*888-661-4279, or 310-661-4279*

*FAX: 310- 537-1173*

### ***MAIN***

*800-421-1244 or 310-537-3700*

*FAX: 310-537-3927*

## CONGRATULATIONS ON YOUR PURCHASE OF YOUR POWER TROWEL!

Each and every walk-behind trowel is designed-without compromise-to produce the finest possible finishes.

---

## **B-Series Trowel**

Table Of Contents .....	3
General Safety Guidelines .....	4
Explanation Of Codes In Remarks Column .....	5
Safety Information .....	6

### **INSTRUCTIONS**

Fuel .....	9
Instructions .....	8-14
Troubleshooting .....	15
Operator Training .....	16
Optional Equipment .....	17
Technical Specifications .....	18
Handle .....	20-21
Quick Pitch Handle .....	22-23
Spider and Blades .....	24-25
Gear Box and Engine Mounts .....	26-27
Engine .....	28-29
Hand Clutch (S/N LJ41888 and below) .....	30-31
Hand Clutch (S/N LJ41889 and above) .....	32-33

Terms and conditions of sale — parts .....	34
--	----

*NOTE: Specification and part number are subject to change without notice.*

## GENERAL SAFETY GUIDELINES

*Failure to follow instructions in this manual may lead to serious injury or even death! This equipment is to be used by qualified and trained personnel only. This equipment should not be operated by persons under 18 years of age.*

Always use proper heavy lifting techniques when moving equipment.

Always make sure that machine is kept in proper operating condition.

Always have throttle position at idle while starting engine.

Always check to make sure that operating area is clear before starting engine.

Always test safety equipment including the safety engine kill mechanisms before operating equipment.

Never place feet on or inside the guard ring while starting the engine.

Never operate this equipment without proper protective clothing including footwear.

Always keep clear of rotating parts when operating.

Never operate with belt guard or any other guards removed.

Never leave machine unattended while running.

Never refuel while engine is running or while engine is hot.

Always refuel in a well ventilated area, away from sparks and open flames.

Never smoke while refueling.

Exhaust fumes are lethal! Operate machine in a well ventilated area, away from places where fumes can accumulate.

## EXPLANATION OF CODE IN REMARK COLUMN

How to read the marks and remarks used in this parts book.

### **Section 1: Items Found In the “Remarks” Column**

Serial Numbers-Where indicated, this indicates a serial number range (inclusive) where a particular part is used.

Model Number-Where indicated, this shows that the corresponding part is utilized only with this specific model number or model number variant.

### **Section 2: Items Found In the “Items Number” Column**

All parts with same symbol in the number column, \*, #, +, %, or ■, belong to the same assembly or kit.

Note: If more than one of the same reference number is listed, the last one listed indicates newest (or latest) part available.

## RECOGNIZE SAFETY INFORMATION, SYMBOLS AND TERMINOLOGY

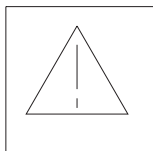

This is the **caution** symbol. Wherever you see this symbol in this manual or on the machine be aware that there is potential for personal injury or damage to equipment. Always follow instructions for safe operation and use.

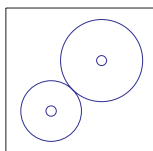

This is the symbol for **gear drive**.

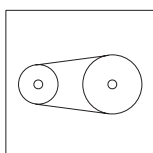

This is the symbol for **belt drive**.

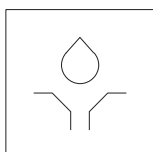

This is the symbol for **lubrication**.

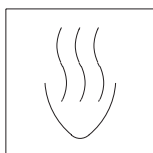

This is the symbol for **radiating heat**. Know that where you see this symbol on the machine parts may be hot.

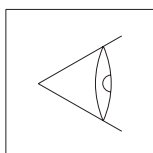

This is the symbol for **examine or check**. Know that where you see this symbol on the machine there will be something that may need to be checked for maintenance.



This is the symbol for **lift point**. Know that this symbol on the machine will point out possible lifting points.

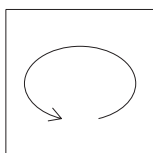

This is the symbol for **continuous rotation**. The direction, clockwise or counter clockwise will be indicated by this symbol.

## FOLLOW ALL SAFETY INSTRUCTIONS

Note: If there are ANY questions regarding this manual (i.e. something is unclear) please contact Multiquip for clarifications.

Read ALL safety instructions carefully. Safety instructions will be found throughout this manual and on the machine. Keep all safety information in good, readable condition. If needed, replacement safety information is available. Contact the nearest Multiquip distributor for replacement items and parts.

Proper machine operation includes training for operators. Operators should be versed on machine safety and operation. Never allow a person who is not properly trained to operate this equipment.

Keep this machine in proper working condition. This includes keeping all safety decals on the machine clean and visible. If decals become unreadable, please call nearest Multiquip dealer for replacements.

Do not modify this machine. Doing so may cause improper operation and may not be safe. This may also reduce machine life. Modifying this machine in any way will void the warranty.

## OPERATE MACHINE SAFELY

Always be aware of the operational area of your machine. Operators need to be careful to keep bystanders and nearby objects at a safe distance from the machine. Never let someone who is untrained operate this machine.

Study the operational area carefully. Remove all dangerous objects from the finishing area. (i.e. protruding rebar or wood). Do not attempt to use the machine where operation appears to be dangerous.

Keep the machine properly maintained and in good working order. This mainly entails keeping the machine clean and serviced. This will allow the finisher to perform to it's fullest potential and provide the longest operational lifetime. Check the safety kill switch before and after every operation. It is good practice to stop the machine with the safety kill switch, to ensure it is operating properly.

Always try to do most work during daylight hours or with sufficient artificial lighting. Visibility must be good for this machine to be used effectively.

Never operate machinery when tired or ill. Operators must be alert and always looking for possible signs of danger or misuse of machinery. Do not operate the machine in dangerous surroundings.

## FUEL

Handle fuel safely. Motor fuels are highly flammable and can be dangerous if mishandled. Do not smoke while refueling. Do not refuel if the engine is hot or running.

Always shut off fuel flow with the fuel line valve after every machine use. Never store the machine with fuel in the tank for any extended period of time.

Clean up spilled fuel immediately!

## PERSONAL PROTECTIVE EQUIPMENT

Always wear proper clothing while operating this equipment. Protective clothing includes (but is not limited to): boots, long sleeve shirt, long pants, gloves, hearing protection and safety eyeglasses. Consult with the construction site foreman to determine what protective clothing is required on the construction site.

## HAZARDOUS MATERIALS

Exposure and mishandling of hazardous material can cause personal injury or damage the environment. Potentially hazardous material used on this machine may include the following: lubricants, fuel, paints and adhesives.

Take care to handle hazardous materials properly. MSDS information sheets are available upon request.

## BE PREPARED FOR EMERGENCIES

Always know the location of the nearest fire extinguisher and first aid kit. Know the location of the nearest telephone. Also know the phone numbers of the nearest ambulance, doctor and fire department. This information will be invaluable in an emergency.

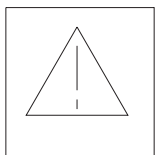

## MAINTENANCE SAFETY

Caution! Disconnect spark plug wires before attempting service.

Before attempting maintenance on this machinery, know the procedure and have the correct tools. Always make sure that the machine is stopped and the spark plug wires are disconnected before attempting service.

Securely support any machine components that must be raised for service (i.e. trowel arms). Never lubricate the machine or attempt service on a running machine. Always allow the machine proper time to cool before servicing.

Keep machinery in proper running condition. Make sure that there is no buildup of concrete, grease, oil or debris. Keep all parts properly installed. Fix damage immediately and always replace worn or broken parts.

Dispose of potentially hazardous waste properly. Examples of potentially hazardous waste are: motor oil, fuel and filters. Use rigid containers for trapping these items. Do not use old food or beverage containers, someone may be misled. Do not pour waste oil or fuel directly onto the ground, down a drain or into any water source.

Inquire what the proper disposal procedures are for waste fuel and oil in your local area.

## MACHINE SAFETY DECALS

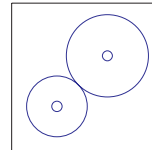

**Gear Drive** — Located on the gearbox.

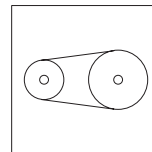

**Belt Drive** — Located on the belt guard.

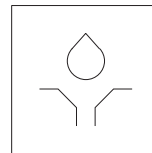

**Lubrication** — Located near the fill hole for gearbox lubricant.

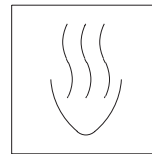

**Hot!** — Located on the muffler shield.

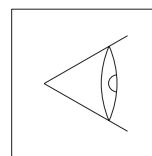

**Check** — Located near the oil level check for the gearbox.



**Lifting point** — Located on the lift bale.

# B-SERIES TROWEL — INSTRUCTIONS

## Putting Into Service

Before packing and shipping, this Power Trowel was run and tested at the factory. If there are any problems, please let us know. Fill out and send the warranty-registration card supplied with the machine. All warranties are void unless this card is on file with us.

Before putting your new finisher into service, read all manuals and instructions carefully. Improper setup, use or maintenance of your equipment could result in personal injury or damage to equipment.

The purpose of this section of the manual is to explain the intended setup, use and maintenance of this equipment.

## Assembly

*Note: READ THESE INSTRUCTIONS CAREFULLY BEFORE ATTEMPTING TO ASSEMBLE ANY COMPONENTS.*

## HANDLE ASSEMBLY — QUICK PITCH™

The QUICK PITCH handle is spring loaded, personal injury or damage could result from improper handling or installation. Attach the handle tube as shown (Step 1). Bolts are to be inserted from the bottom side of the handle. Note that the bolt on the engine side must have a washer between the gearbox and the nut. The

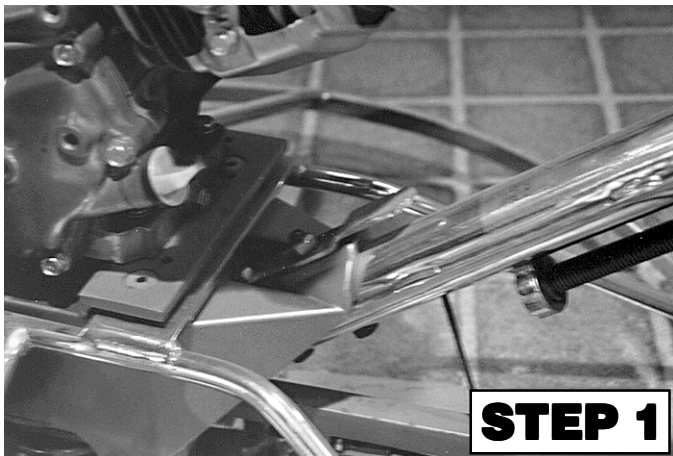

second bolt carries the auxiliary lift handle bracket in the place of a washer.

After the handle is connected to the trowel, grasp the QUICK PITCH control from operator's position. Pull the adjustment trigger on the QUICK PITCH handle and push the entire handle towards the engine as far as possible (Step 2). This will compress the spring inside the handle. Considerable force may be required to do this! Release the trigger to lock the spring in this compressed position.



Remove one brass nut from the cable end. Thread the second brass nut towards the cable as far as possible (Step 3). Insert the cable end into the yoke as shown. Replace the brass set nut on the cable end. Tighten the set nut by hand as far as possible to remove slack from the cable (Step 4). Using a wrench, tighten the locking nut on the other side of the boss to lock the cable in place (Step 5).





## B-SERIES TROWEL — INSTRUCTIONS



### Preload adjustment for QUICK PITCH

After the handle is installed on the machine, spring preload adjustment will be required. Locate the adjustment screw on the underside of the handle. A decal has been placed there to assist in the adjustment. Turn the screw to adjust until it lines up with the arrow on the decal matching your setup. Test pitch control operation. Adjust if necessary.



If you want to be able to increase the blade pitch using less arm force, adjust the block away from the gearbox. Be aware, this will also require more force to decrease the blade pitch. If you want to be able to decrease the blade pitch using less arm force, adjust the block toward the gearbox.

### HANDLE ASSEMBLY — STANDARD HANDLE

Turn the pitch adjustment knob (located on the operator end of the handle) counter-clockwise until resistance is felt.

Attach the handle tube to gearbox as shown in the QUICK PITCH handle installation. Bolts are to be inserted from the bottom side of the handle. Note that the bolt on the engine side must have a washer between the gearbox and the nut. The second bolt carries the auxiliary lift handle bracket in the place of a washer.



Remove one brass nut from the cable end. Thread the second brass nut towards the cable as far as possible. Insert the cable end into yoke as shown in the QUICK PITCH installation. Replace the brass set nut on the cable end. Tighten the set nut by finger as far as possible to remove slack from the cable. Using a wrench, tighten the locking nut on the other side of the boss to lock the cable in place.

### SAFETY KILL WIRE

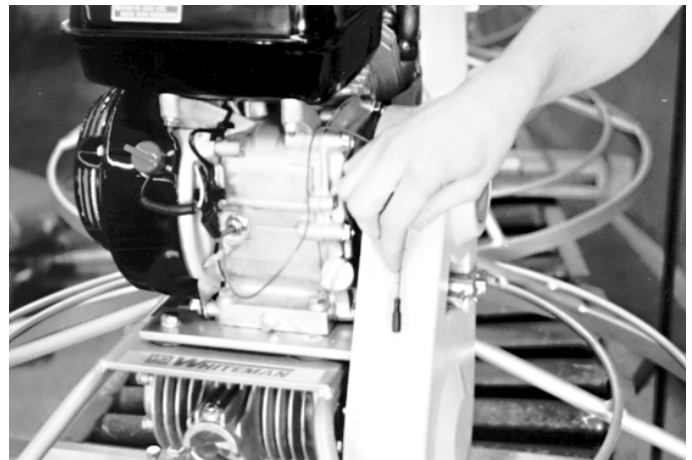

Locate the red wire protruding from the handle tube and connect it to the red wire tail on the engine. Test to insure proper operation!

### HANDLE HEIGHT ADJUSTMENT

If handle height adjustment is desired, a handle wedge kit can be purchased for your machine by ordering Part Number 2576 from your Multiquip dealer. These wedges are placed between the handle and the gearbox to adjust the operating height of the handle. This kit comes complete with wedges, new bolts and installation instructions. This will move your operating handle position up or down approximately 3" (76mm).

### THROTTLE CABLE INSTALLATION

*Note: A red wire piece has been placed on the engine throttle assembly to show where the throttle cable from your handle should be placed.*

# B-SERIES TROWEL — INSTRUCTIONS

## General Instructions

Set the throttle lever to the idle position by pushing it away from the operator's position towards the engine (counter clockwise from the top- Step 1). Loosen the screw that crimps the throttle cable to allow free movement of throttle cable (Step 2).

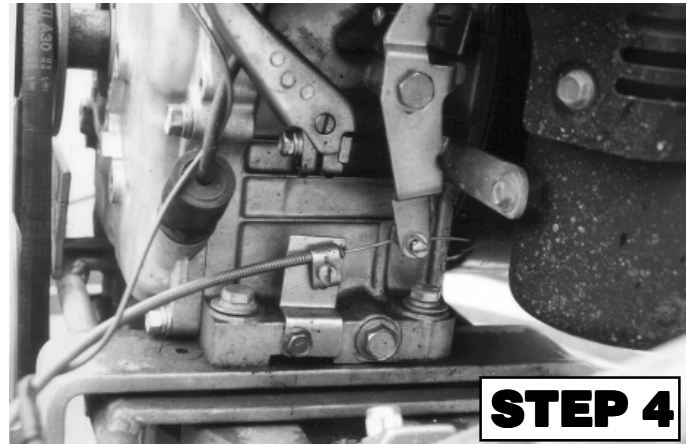

Connect the throttle cable to the engine. Keep in mind there should be a piece of wire installed on the machine to show you where to route the throttle cable. When connecting the cable housing, make sure that no more than 1/4" (6.4mm) of the cable housing protrudes past the housing clamp on the engine (Step 4). After the cable has been installed on the engine, tighten the clamp on the throttle control, operator position of the handle to lock the throttle cable at the proper length.

These are general instructions. Installation of the throttle cable may vary for different engine configurations. Please look for more detailed instructions inside the box containing the handle. These more detailed instructions should provide adequate guidance for installing.



On Robin engines, the hook on the engine end of the throttle wire must be removed. Make the cut as shown (Step 3). The rest of the engine will not require this modification to the throttle cable.

# B-SERIES TROWEL — INSTRUCTIONS

## Handling

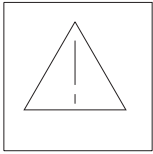

Machine is heavy and awkward to move around. Use proper heavy lifting procedures and **DO NOT LIFT THE MACHINE BY GUARD RINGS.**

## Moving the Machine

### Auxiliary Lifting Tube

Remove the auxiliary lifting tube located on top of the main handle. Insert the tube into the socket located on the opposite side of the gearbox from the handle. Make sure that the hole in the tube engages with the pin in the socket. With one person lifting from the main handle, and another lifting from the auxiliary lifting tube pick up the machine to move it, as shown in the following diagram.

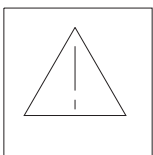
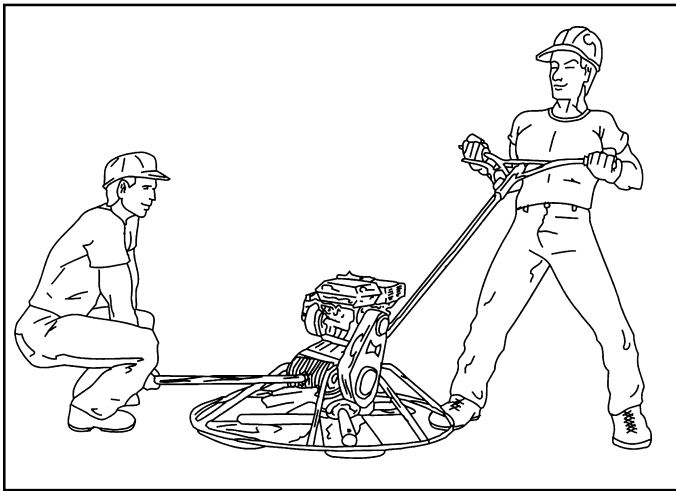

**Caution!** The machine must be stabilized by the person carrying the operator's handle. If it is not stabilized properly by this person it will rotate upside down.

### Lift Bale

The lift bale is optional on new machines. It provides an optimal lift point for moving the finisher. Lift bales can be used to lift a machine up onto a building with a crane. They can also be used to lift a machine up onto a slab with a forklift machine. Using a crane to move a machine with a lift bale is highly recommended, and is perfectly safe for the machine. Extra care should be taken when lifting the machine off the ground, though. Serious damage to the machine or personal injury could be caused by dropping a finisher. See "Optional Equipment" in this manual for ordering information.

## Machine Operations

### CONTROLS

#### Safety Kill Switches

Your finisher has been equipped with a safety kill switch or a hand operated clutch. Safety kill switches should be tested every time the engine is started. *Note: NEVER disable or disconnect the kill switch. It is provided for operator safety. Injury may result if it is disabled, disconnected or improperly maintained.*

#### Centrifugal Type

This is a red switch located on the main handle tube. The switching mechanism should operate freely and should be kept in this condition. With the switch in the OFF position, the engine should not start or run. The purpose of this switch is to stop the engine in a runaway situation, (i.e.-the operator releasing the handle during operation).

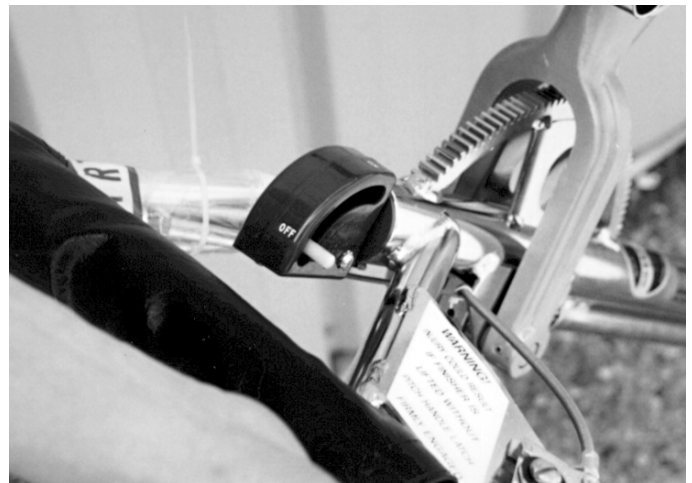

#### Hand Clutch

Some finisher models are equipped with a hand operated clutch. These units are not equipped with a safety kill switch since the unit automatically stops rotating when the clutch lever is released. Clutch operation should be tested each time the machine is started.

Do not let the machine sit unused with the engine at high speed for an extended period of time. It will cause premature belt wear or may destroy the belt. Always set the engine speed to idle when the hand clutch is disengaged.

# B-SERIES TROWEL — INSTRUCTIONS

## Blade Pitch — Standard Handle

The pitch control on machines equipped with the standard handle is a big star-wheel knob located at the operator end of the main handle tube. Pitch is controlled by turning the knob. Clockwise for increased blade pitch, counter-clockwise for decreased blade pitch.



## Blade Pitch — QUICK PITCH™ handle

Pitch is controlled on machines with this option by a T-shaped lever located on the top of the main handle tube. To change the blade pitch, pull the locking control up to the T-handle. Pulling the handle towards the operator will increase blade pitch. Pushing the handle away from the operator will decrease the blade pitch. See page 8 for adjustment.

## Electric Control Switch (electric motors only)

Located on the control handle, this switch transfers power to the electric motor when grasped.

## Electric On-Off Switch (electric motors only)

Located on the handle, it is the main power control switch.

## Engine Operation

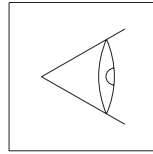

Check the oil level before starting the engine. Because of the number of engine options, please refer to engine owner's manual for specific instructions regarding engine operation.



## Gearbox Oil Level

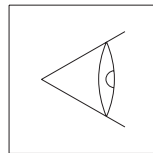

Check the gearbox oil level daily.

Check the gearbox oil level by removing the plug located on the side of the gearbox. It will be clearly marked by the "check" decal (see Machine Decals section). Take care when removing plugs on the gearbox, there are two of them. Removal of the bottom-most plug (DRAIN PLUG) will drain the oil. The level should be up to the bottom of the fill plug hole, located approximately half way up the side of the gear box. If needed, refill with specifically formulated gearbox lubricant (P>N> 10139) or ISO 680 oil.

## Operation

The following steps are intended as a basic guide to machine operation, and are not to be considered a complete guide to concrete finishing. We suggest that all operators (experienced and novice) read "Slabs on Grade" published by the American Concrete Institute, Detroit, Michigan. Read the "Training" section of this manual for more information.

1. Check oil levels in the engine and gearbox.
2. Check to make sure that the fuel control valve is on and fuel is in the tank.
3. Set safety kill switch (if equipped with centrifugal type clutch) to ON position.
4. Set throttle to idle position.

# B-SERIES TROWEL — INSTRUCTIONS

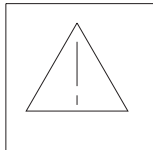

**NEVER** start the engine with the throttle above the idle position.

5. Grasp the control handle with left hand. Pull slowly on starter rope until resistance is felt, then pull briskly to start the engine. If the engine fails to start after several tries, consult the engine owner's manual.

6. After the engine starts, let it warm up by idling for a few minutes.

7. Test the safety kill switch. If you have the centrifugal type clutch, try momentarily switching the kill switch to the OFF position. If your safety kill switch is working properly, the engine on your finisher should stop.

8. Get into the operator's position behind the handle. With a secure foothold and a firm grasp on the handles slowly increase the engine speed until the desired blades speed is obtained. If your finisher has a hand clutch, set your engine speed with the throttle, then pull on the hand clutch lever to start the blades. Adjust the blade speed after the hand clutch is fully engaged.

9. To maneuver the machine, gently lift up on or press down on the main trowel handle. To move the machine to the operator's left-lift up on the handle, to move machine to the right-push down on the handle.

10. The best method for finishing concrete is to slowly walk backwards with the machine, guiding the machine from side to side as you do so. See the diagram in than "Suggested Training Checklist" at the end of this manual.

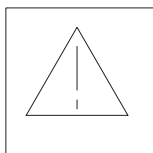

**Always** look behind you to avoid hazards before moving backwards.

## Cleanup

**NEVER** allow concrete to harden on the power trowel.

Immediately after use, wash any concrete off your trowel with water. Be careful not to spray water on the engine. An old paintbrush or broom may help loosen any concrete that has started to harden.

Coat the blades and blade arms with diesel fuel after cleaning. This should help prevent rusting and allow for easier cleanup in the future.

## Maintenance (Service, Adjustment and Repair)

**Note:** See the engine manual supplied with your machine for appropriate engine maintenance schedule.

There is a "Daily Preoperation Check List" at the end of this manual. Please feel free to make copies of it and use it on a daily basis.

## Maintenance Schedule

### Daily (8-10 Hours)

Check the fluid levels in the engine and gearbox.

### Weekly (50-60 Hours)

Relube arms, thrust collar and clutch.

Replace the blades if necessary.

Check and clean or replace the engine air filter as necessary.

### Monthly (200-300 Hours)

Remove, clean, reinstall and relube the arms, thrust collar and clutch.

Adjust the blade arms.

### Yearly (2000-2500 Hours)

Check and replace if necessary the arm bushings, thrust collar bushings, shaft seals and belts.

Check pitch control cable for wear.

## SERVICE PROCEDURES

### Checking Belt Tension

The first indication of belt wear is a reduced blade speed despite the engine running at full speed. Inspect belts often for signs of damage or excessive wear.

There is no method for manual adjustment of belt tension. Excessively worn belts must be replaced.

### Blade Pitch Adjustment Procedure

The maintenance adjustment of blade pitch is an adjustment that is made by a bolt on the arm of the trowel blade finger. This bolt is the contact point of the trowel arm to the lower wear plate on the spider. The goal of adjustment is to promote consistent blade pitch.

There are some things to look for when checking to see if adjustment is necessary. Is the machine wearing out blades unevenly (i.e. one blade is completely worn out while the others look new)? Does the machine have a perceptible rolling motion? Look at the machine while it is running, do the guard rings "rock up and down" relative to the ground? These are some indications that the blade pitch needs to be adjusted.

## B-SERIES TROWEL — INSTRUCTIONS

The easiest way to make this adjustment is to use the Trowel Arm Adjustment Fixture, Part Number 1817 (pictured below). This fixture will allow consistent adjustment of the trowel arm fingers. It comes with all the hardware necessary to properly accomplish this maintenance and instructions on how to properly utilize this tool. Adjusting the trowel arm fingers without a fixture requires a special talent.



If a trowel arm adjustment fixture is not available and immediate adjustment is necessary, we suggest the following procedure. If you can see or feel which blade is pulling harder, adjust the bolt that corresponds to that blade. Another way to determine which blades need adjusting is to place the machine on a flat surface and pitch the blades as flat as possible. Now, look at the adjustment bolts. They should all barely make contact with the lower wear plate on the spider. If you can see that one of them is not making contact, some adjustment will be necessary.

It is possible to either adjust the “high” bolts down to the level of the one that is not touching, or adjust the “low” bolt up to the level of the higher ones. Verify that after adjustment, the blades will pitch correctly. Often times, if the blades are incorrectly adjusted, they will not be able to pitch flat. This is due to the adjusting bolts being raised too high. Conversely, some times the adjusting bolts are too low and the blades cannot be pitched enough.

### Changing a Blade

It is recommended that all the blades be changed at the same time. The machine may wobble or bounce if only some of the blades are changed at one time.

1. Place the machine on a flat, level surface. Adjust the blade pitch control to make the blades as flat as possible. Note the blade orientation on the trowel arm.

2. Remove the bolts and lock washers on the trowel arm, then remove the blade.
3. Scrape all concrete particles from the trowel arm.
4. Install the new blade, maintaining the proper orientation for direction of rotation.
5. Affix the bolts and lock washers.
6. Repeat steps 2-6 for all of the remaining blades.

### Hand Clutch Adjustment

Some finishers are equipped with a hand-operated clutch instead of an automatic centrifugal clutch. Two types of hand clutches have been installed. Both are belt-tightener type clutches. They operate by removing slack in the V-belt which then transmits power from the engine to the gearbox.

There are two reasons to adjust the hand clutch: 1) operator comfort; 2) initial belt stretch and break-in.

The easiest and most simple adjustment is to adjust the clutch cable housing using the adjusting nut located on the clutch lever. Rotating the nut provides either more or less (depending upon the direction of rotation) clutch engagement.

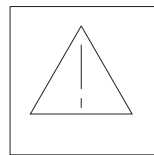

**Always check to verify that the clutch will properly disengage!**

For operator comfort: start the trowel following the instruction given earlier in this manual. Move the throttle lever so that the engine is running about 1/4 to 1/3 of full speed. Grip the trowel handle firmly and carefully engage the clutch by squeezing the clutch lever toward the handle with your left hand. After the trowel is stabilized and you feel comfortable with its operation, use your right hand to adjust the housing adjustment nut. Rotating the nut so that it backs out of the lever housing increases the engagement and also the squeezing force required to keep it engaged. Too much squeezing force may cause premature hand fatigue. Too little squeezing force may cause belt slippage and premature belt wear. Each operator should experiment with the adjustment to get the optimum combination of squeeze force and belt grip.

After initial break-in (approximately 8 hours) the above procedure should be repeated to attain optimum operator comfort and belt wear.

After considerable belt wear, the adjustments mentioned above may have a little or no effect on clutch engagement. If this is the case, the belt should be replaced.

## B-SERIES TROWEL — TROUBLESHOOTING

### TROUBLESHOOTING

SYMPTOM	POSSIBLE PROBLEM	SOLUTION
---------	------------------	----------

Engine running rough or not at all.

Kill switch off or malfunctioning? Make sure that the kill switch is on or replace switch if necessary.

Other problems? Consult engine manufacture's manual.

Safety kill switch not functioning.

Loose wire connections? Check wiring. Replace switch if necessary.

Bad contacts? Replace switch.

Clutch slipping or sluggish response to engine speed change.

Worn belts? Replace.

Dirty centrifugal clutch? Disassemble and clean the clutch.

Worn out centrifugal clutch? Replace entire clutch.

Hand clutch out of adjustment? Adjust as per instructions in Maintenance section.

Worn hand clutch parts? Replace parts as necessary.

Worn bearings in gearbox? Rotate input shaft by hand. If it rotates with difficulty check the input and output shaft bearings. Replace if necessary.

Worn or broken gears in gearbox? Check in particular to verify that the gearbox output shaft rotates when the input shaft is rotated. Replace both worm and worm gear as a set.

If trowel "bounces, rolls concrete, or makes uneven swirls in concrete".

Blades? Make certain blades are in good condition, not excessively worn. Finish blades should measure no less than 2" (50 mm) from the blade bar to the trailing edge, combo blades should measure no less than 3-1/2" (89mm). Trailing edge of blade should be straight and parallel to the blade bar.

Spider? Check that all blades are set at the same pitch angle as measured at the spider. A field adjustment tool is available for height adjustment of the trowel arms (see Optional Equipment section).

Bent trowel arms? Check the spider assembly for bent trowel arms. If one of the arms is even slightly bent, replace immediately.

Trowel arm bushings? Check the trowel arm bushing for tightness. This can be done by moving the trowel arms up and down. If there is more than 1/8" (3.2mm) of travel at the tip of the arm, the bushings should be replaced. All bushings should be replaced at the same time.

Thrust collar? Check the flatness of the thrust collar by rotating it on the spider. If it varies by more than 0.02" (0.5mm) replace the thrust collar.

Thrust collar bushings? Check the thrust collar by rocking it on the spider. If it tilts more than 1/16" (1.6mm) (as measured at the thrust collar O.D.), the bushing in the thrust collar should be replaced.

Thrust bearing worn? Check the thrust bearing to see that it is spinning free and has not worn into the thrust cap. Replace if necessary.

Machine has a perceptible rolling motion while running.

Main shaft? The main output shaft of the gearbox assembly should be checked for straightness. The main shaft must run straight and cannot be more than 0.003" (0.08mm) out of round at the spider attachment point.

Blade pitch? Check blades for consistent pitch. Adjust per Maintenance section instructions if necessary.

## Operator Training

### SUGGESTED TRAINING

***Note: ONLY QUALIFIED AND EXPERIENCED PERSONNEL SHOULD OPERATE THIS EQUIPMENT***

Before taking your new equipment to the job site for its first use, there are a few things that should be considered before operation.

### Handling

Know how to transport your trowel properly. Keep in mind that you will need to place your trowel on a slab of concrete in the middle of construction area. How will you accomplish this? Do you need any special equipment for lifting or transport? These are questions that you should be able to answer.

### Operation

Perhaps it would be wise to familiarize yourself with machine operation before placing your machine on a slab. It would of use to understand how your trowel will behave and how it is controlled. The best way to do this is to test run your machine.

To test run your machine, place it on a flat piece of existing finished concrete. Before starting the machine, make sure that the area around the machine is clear of any obstructions and people. Test running your machine will give a good idea as to how the machine will operate under normal conditions. Keep in mind that running a machine on dry concrete could wear your blades at an accelerated rate.

### Training Checklist

For proper operator training please use the attached sheet OPERATOR TRAINING CHECKLIST. It is located at the end of this manual. This sheet will list some of the minimums for basic operation of the machine. Please feel free to detach it and make copies. This sheet is a checklist by which an experienced operator can provide training to a new operator. This sheet should help to familiarize the new operator with the machine. It covers basic machine controls and use, but it is not to be considered a complete training exercise. Nor is it to be considered a complete guide to concrete finishing.



## B-SERIES TROWEL — OPTIONAL EQUIPMENT

### BLADES

**Note: BLADES SHOULD BE CHANGED WHEN THEY FAIL TO FINISH CONCRETE IN A SATISFACTORY MANNER.**

Blades are a vital part of finishing concrete. This finisher has been designed to finish concrete and are built to stringent quality standards out of the finest trowel steel. If you need replacement blades, consult your parts list in this manual for part numbers and order them from your Multiquip parts dealer or importer.

#### Combo Blades

This trowel was equipped with combination FLOAT/FINISH blades as original equipment. These blades have been designed for optimum performance in both the floating and finishing operations. These blades are versatile and should take care of most troweling needs.

#### Finish Blades

These blades have been specifically designed for finish operations with this trowel. They will provide a premium surface finishing capability from your trowel. They should only be used after the concrete has set to the point where the machine does not sink into the concrete when placed on it .

#### Clip-On Float Blades

These blades will clip on to an existing installed blade, allowing your finisher to float on "wet" concrete so that the troweling operation can begin as early as possible. They are easily removable, so that after the floating operation, when the concrete is sufficiently cured, they can be removed to expose the finish blades for continued troweling.

#### Float Discs

These round discs attach to the spiders and allow the machine to "float" on "wet" concrete. The disc design allows early floating and easy movement from wet to dry areas. They are also quite effective in embedding large aggregates and surface hardeners.

#### FIELD TROWEL ARM ADJUSTMENT TOOL

If blades show uneven wear patterns or some tend to wear out faster than others, the trowel arms may need to be adjusted. Multiquip makes a special tool that will adjust all of the trowel arms consistently, Part Number 1817-Trowel Arm Fixture.

Shown here is the adjustment fixture with an arm. As each arm is

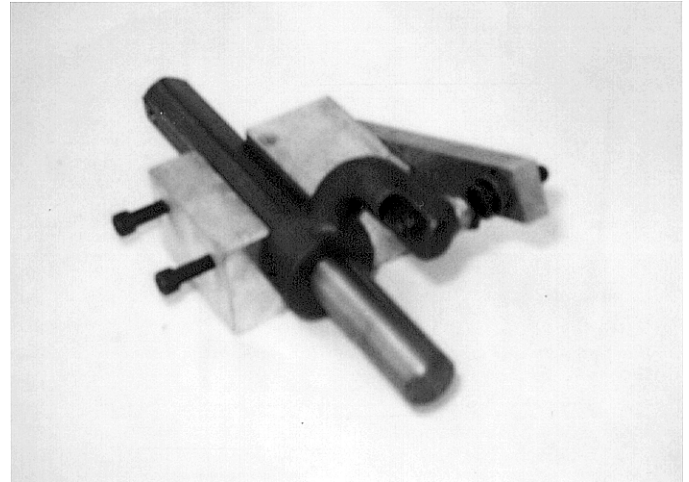

locked into the fixture, the arm bolt is adjusted to where it contacts a stop on the fixture. This will consistently adjust all of the trowel arms, keeping the finisher as flat and evenly pitched as possible. See Blade Pitch Adjustment Procedure in the Maintenance section of this manual for more information.

#### LIFT BALE

There is a heavy duty, center balance type lifting bale made specifically for your trowel. These bales are ideal for lifting and transporting your trowel. They are designed to lift the finisher and balance it on it's center of gravity, providing great stability while lifting.

#### GRINDING ATTACHMENTS

Available grinding attachments are used for grinding surface imperfections or joints. These attachments allow greater utilization of your trowel.

# B-SERIES TROWEL — TECHNICAL SPECIFICATIONS

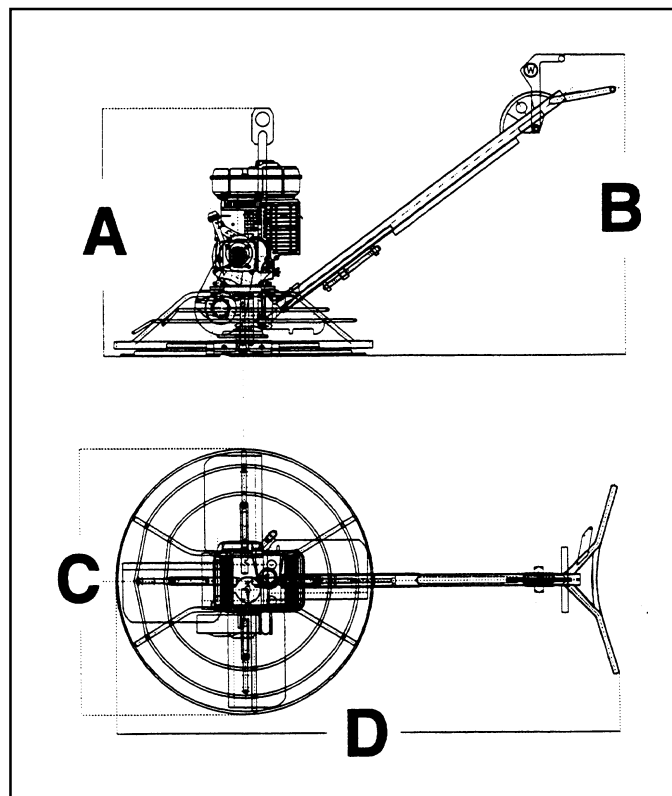

## TECHNICAL SPECIFICATIONS

MODEL J B

A 36.7 in. 931.6mm 34.5 in. 876.2mm

B 41.4 in. 1044.2mm 41.1 in. 1044.2mm

C 36.5 in. 927.1mm 46 1168.4mm

D 70.5 in. 1789.4mm 75.2 in. 1910.1mm

Weight 150 lb. 330 Kg 240 lb. 528 Kg

Sound Pressure\* 94 dB 94 dB 97 dB 97 dB

Vibration\*\* 2.0g 19.6m/s<sup>2</sup> 2.5g 24.5 m/s<sup>2</sup>

Blade Speed (max.) 129 rpm @ 4000 129 rpm @ 4000 129 rpm @ 4000 129 rpm @ 4000

engine rpm engine rpm engine rpm engine rpm

Blade Tip Speed (max.) 1182pm 6.0 m/s 1478 fpm 7.5m/s

\*Sound pressure is A weighted. Measured at the operator's ear position while running the machine on curing concrete in a manner most often experienced in "normal" circumstances. Sound pressure may vary depending upon the condition of the concrete. Hearing protection is always recommended.

\*\*Vibration level indicated is the maximum RMS value obtained at the handle grip while operating the machine on curing concrete in a manner most often experienced in "normal" circumstances. Values were obtained from all three axes of motion. The values shown here represent the maximum RMS value from these measurements.



# B-SERIES TROWEL — HANDLE

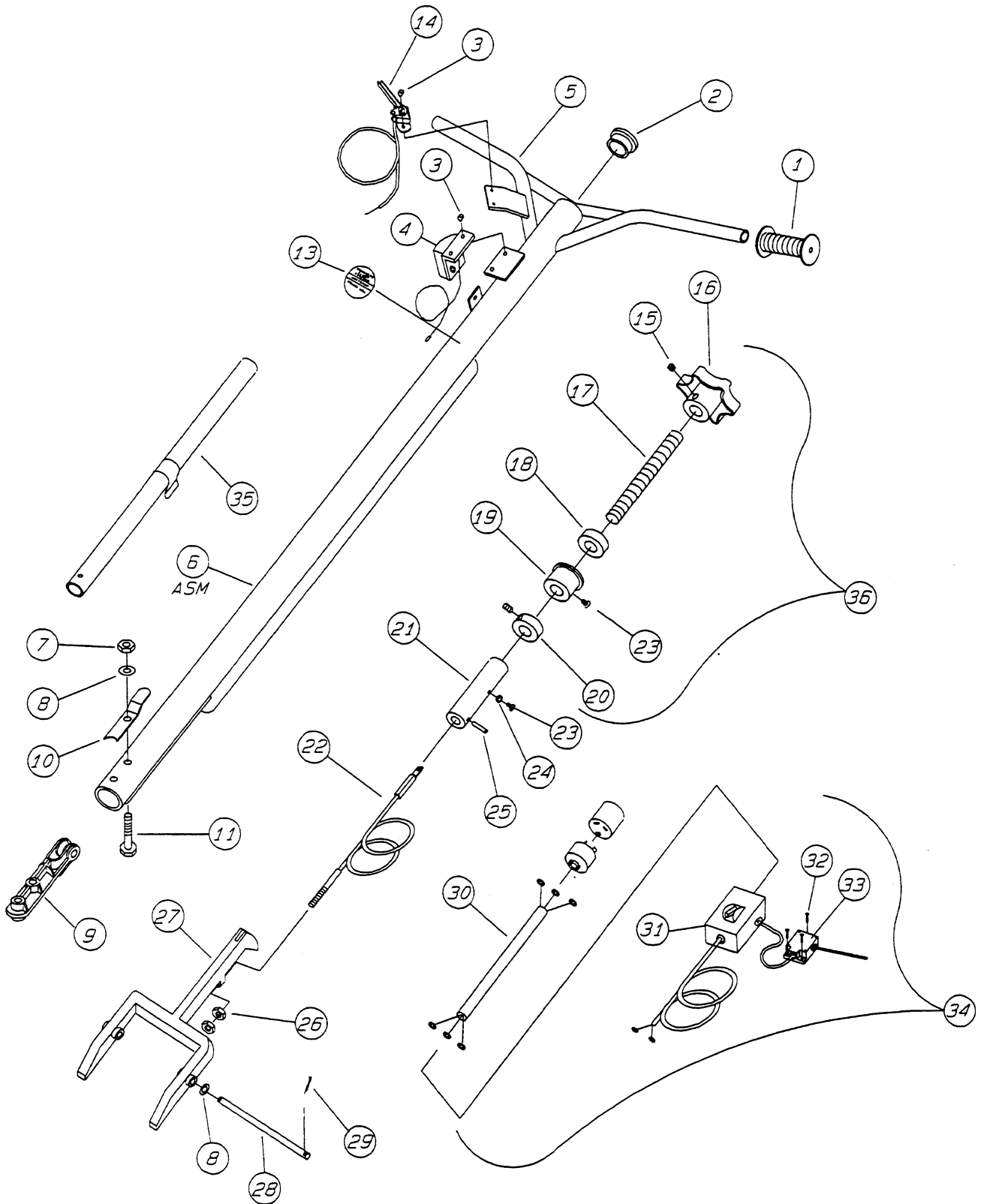

# B-SERIES TROWEL — HANDLE

## B-SERIES POWER TROWEL HANDLE

<u>NO.</u>	<u>PART NO.</u>	<u>PART NAME</u>	<u>QTY.</u>	<u>REMARKS</u>
1	0189	HANDLE GRIP	2	
1	4634	HANDLE GRIP (ELECTRIC MODEL)	2	
2	1102	PLUG	1	
3	0304	RHMS 10-24X 1/4"	4	
4	1103	SAFETY SWITCH ASSY	1	
5	1101	HANDLE ONLY	1	
5	1907	HANDLE ONLY (ELECT. MODEL)	1	
6		HANDLE ASSY .....	1	CONTACT UNIT SALES DEPT./ ACCESSORY ITEM
7	10133	LOCK NUT 3/8-16	2	
8	10136	FLAT WASHER 3/8"	4	
9	1117	SUPPORT BLOCK ASSY (PULLEY & PIN)	1	
10	0190A	HOLDER	1	
11	1121	HHCS 3/8-16X2.3/4"	2	
13	1492	2.1/2" CHROME DECAL	1	
14	0302	THROTTLE CONTROL ASSY	1	
15#	0185	SHSS 3/8-16X3/8"	1	
16#	0280B	HAND WHEEL	1	
17#	1478	TROWEL CONTROL SHAFT	1	
18#	0281	BEARING	1	
19#	1111	BEARING	1	
20#	3615	SET COLLAR (WITH SET SCREW)	1	
21	1113	SLIDE BLOCK & CABLE ASSY	1	
22	1115	CONTROL CABLE ASSY	1	
23#	0786	BCHS 1/4-20X3/8" NY-LOC	2	
24	0786A	SPACER	1	
25	1114	ROLL PIN 5/32 X1.3/8"	2	
26	1116	BRASS JAM NUT 5/16-18	2	
27	1150	YOKE ARM	1	
28	1151	ARM PIN	1	
29	0683	COTTER PIN 3/32X3/4"	2	
30*	2505	PIGTAIL ASSY (ELECT. MODEL)	1	
31*	01751	SWITCH BOX (ELECT. MODEL)	1	
32*	5044A	FHMS 10-32X3/4" (ELECT. MODEL)	1	
33*	1268	MICRO SWITCH (ELECT. MODEL)	1	
34	1189	SWITCH CONDUIT ASSY (ELECT. MODEL) ...	1	INCLS. ITEMS W/*
35	0190	LIFT HANDLE ASSY	1	
36	1110	TROWEL CONTROL ASSY .....	1	INCLS. ITEMS W/#

# B-SERIES TROWEL — QUICK PITCH HANDLE™

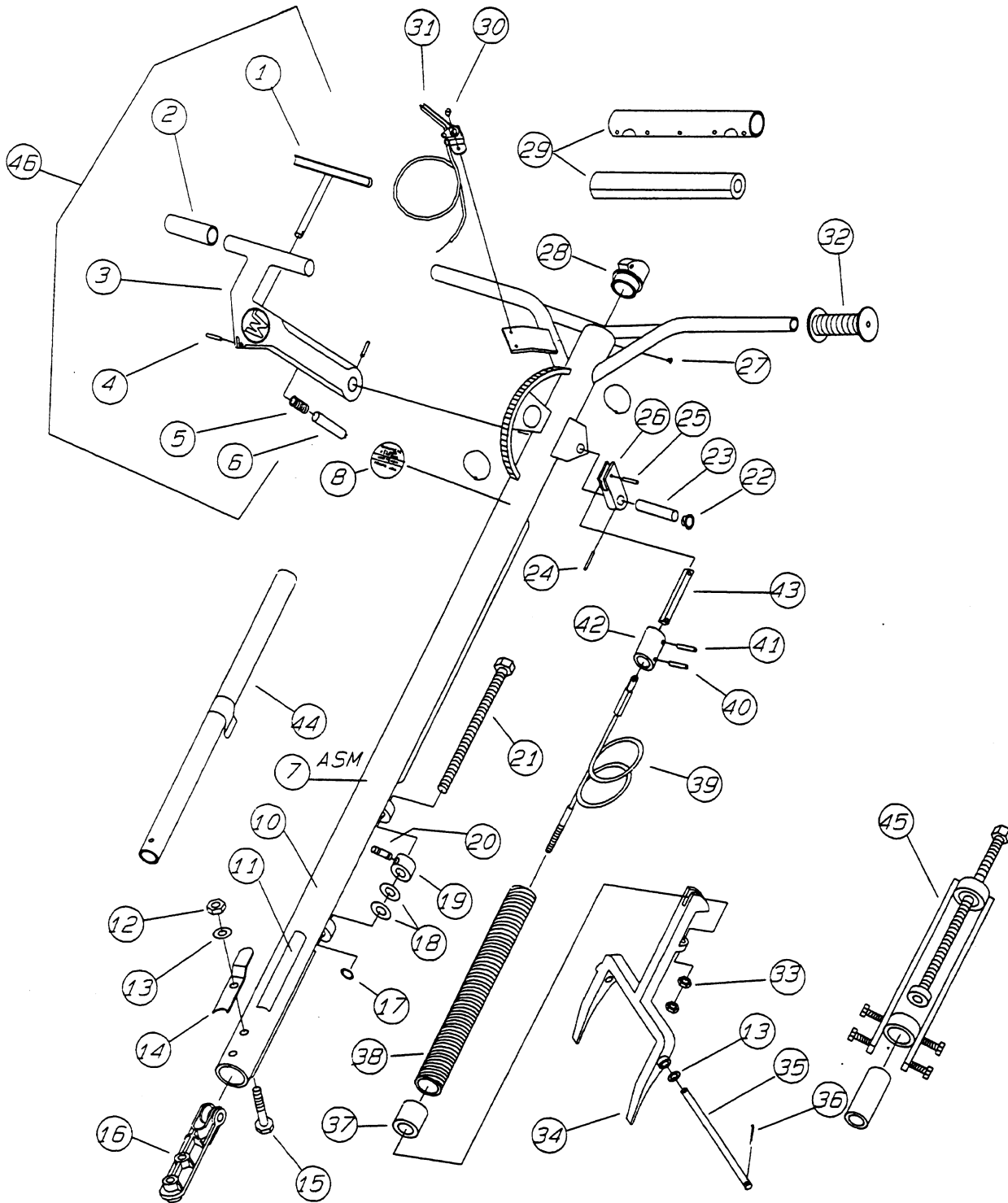

# B-SERIES TROWEL — QUICK PITCH HANDLE™

## B-SERIES POWER TROWEL QUICK PITCH HANDLE

NO.	PART NO.	PART NAME	QTY.	REMARKS
1*	1746	QUICK PITCH TRIGGER	1	
2*	1724	CONTROL HANDLE GRIP	2	
3*	1707	CONTROL HANDLE .....	1 .....	INCLS. P/N 1739 BUSHING
	1739	BUSHING	2	
	1734	WARNING DECAL		
4*	1729	ROLL PIN 3/16X1.1/4"	3	
5*	1706	LATCH RETURN SPRING	1	
6*	1745	LATCHING SHAFT	1	
7		HANDLE ASSY COMPLETE .....	1 .....	CONTACT UNIT SALES DEPT./ACCESSORY ITEM
8	1758	FINISHER HANDLE PATENT DECAL	1	
10	1701	HANDLE ONLY	1	
11	1735	PRE-LOAD DECAL	1	
12	10133	LOCK NUT 3/8-16	2	
13	10136	FLAT WASHER 3/8"	4	
14	0190A	HOLDER	1	
15	1121	HHCS 3/8-16X2.3/4"	2	
16	1117	SUPPORT BLOCK ASSY	1	
17	1737	SNAP RING	1	
18	1733	HARDENED WASHER 1/2"X1/32"	2	
19	1718	PRE-LOAD ADJUSTMENT NUT	1	
20	1732	PRE-LOAD ADJUSTMENT PIN	1	
21	1717	PRE-LOAD ADJUSTMENT SCREW	1	
22	1719	PIVOT PLATE BUSHING	2	
23	1711	CONTROL SHAFT	1	
24	4568	ROLL PIN 3/16"X1"	1	
25	1731	ROLL PIN 1/4"X3/4"	1	
26	1708	SLIDE CONTROL ARM	1	
27	1743	PHSTS 1/4X1/2"	1	
28	1727	SAFETY SWITCH ASSY	1	
29	1730	HANDLE PAD & COVER	1	
30	0304	RHMS 10-24X1/4"	2	
31	0302	THROTTLE CABLE ASSY	1	
32	0189	HANDLE GRIP	2	
33	1116	BRASS JAM NUT 5/16-18	2	
34	1150	YOKE ARM	1	
35	1151	YOKE PIN	1	
36	0683	COTTER PIN 3/32"X3/4"	2	
37	1716	PRE-LOAD ADJUSTMENT BLOCK	1	
38	1715	CONTROL BALANCE SPRING	1	
39	1714	CONTROL CABLE ASSY	1	
40	1757	ROLL PIN 3/16"X1.3/8"	1	
41	1726	ROLL PIN 1/4"X1.3/8"	1	
42	1712	CONTROL CABLE SLIDE BLOCK	1	
43	1709	CONTROL ARM CONNECTOR	1	
44	0190	LIFT HANDLE ASSY	1	
45		TOOL ASSY FOR UNLOADING SPRING ..	1 .....	CONTACT UNIT SALES DEPT./ACCESSORY ITEM
46	1754	T-HANDLE ASSY .....	1 .....	INCLS. ITEMS W/*

# B-SERIES TROWEL — SPIDER AND BLADES

B-SERIES POWER TROWEL  
SPIDER & BLADES

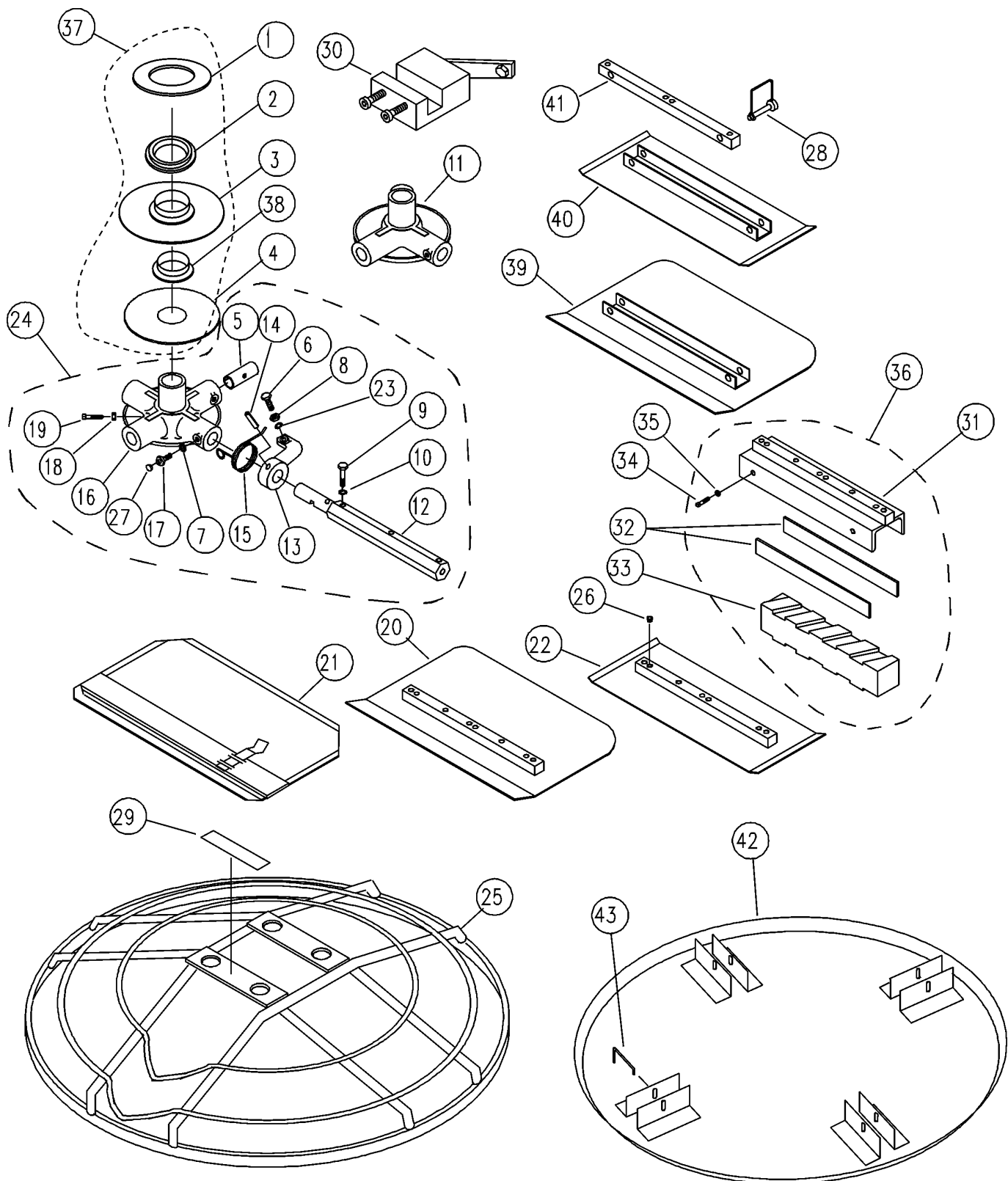



# B-SERIES TROWEL — SPIDER AND BLADES

## B-SERIES POWER TROWEL SPIDER & BLADES

NO.	PART NO.	PART NAME	QTY.	REMARKS
1#	12208	WEAR RING	1	
2#	12778	FLANGE BEARING	1	
3#	10793	THRUST COLLAR	1	
4#	1154A	WEAR PLATE .....	1	INCLUDES ITEMS W/\$
5	1157A	BEARING INSERT	3,4	
6	0164B	FULL THREAD, RADIUS HEAD 3/8-16X1.1/4"	3,4	
7	1875	INT. SHKP. WASHER 3/8"	3,4	
8	1876	JAM NUT 3/8-16 CLASS 2B	3,4	
9	0105	HHCS 5/16-19X1.1/2"	6,8	
10	0161C	LOCK WASHER 5/16"	6,8	
11	1156	SPIDER PLATE ONLY (B-3 MODEL)	1	
12	2827	TROWEL ARM EXTENDED, 16 1/2"	3,4	
12	2828	TROWEL ARM 11.3/4"	3,4	
13	1163	TROWEL ARM LEVER	3,4	
14	4164	ROLL PIN 5/16X1.3/4"	3,4	
15	1316	SPRING (RIGHT HAND)	3,4	
16	1161	SPIDER PLATE ONLY (B-4 MODEL)	1	
17	1322	RETAINING SCREW ASSY	3,4	
18	1456	HEX NUT 3/8-16	1	
19	1167A	SHSS 3/8-16X1.1/2" CONE POINT	1	
20		COMBO FLOAT & FINISH BLADE .....	3,4	CONTACT UNIT SALES DEPT./ACCESSORY ITEM
20		ENDURO COMBO FLOAT & FINISH BLADE .....	3,4	CONTACT UNIT SALES DEPT./ACCESSORY ITEM
21		FLOAT BLADE .....	3,4	CONTACT UNIT SALES DEPT./ACCESSORY ITEM
22		FINISH BLADE .....	3,4	CONTACT UNIT SALES DEPT./ACCESSORY ITEM
22		ENDURO FINISH BLADE W/ROTATING .....	3,4	CONTACT UNIT SALES DEPT./ACCESSORY ITEM
23	0202	HHCS 5/16-18X1" RING	3,4	
24	0201	GUARD RING LUG RING	3,4	
25	2273	STATIONARY GUARD RING	1	
26	1434	TROWEL LUG (FINISH BLADE ONLY)	3,4	
27	1162A	LUBRA-CAP	3,4	
28	1482	STABILIZER RING 14 1/2" ARM (B-3 MODEL)	1	
28	1483	STABILIZER RING 14 1/2" ARM (B-4 MODEL)	1	
29	6014C	HEX NUT 5/16-24	6,8	
30	1237	HHCS 5/16-18X7/8" NY-LOC	3,4	
31	0490	SHCS 7/16-14X1"	3	
32	0487	SHCS 3/8-16X1/2"	20	
33	0489	GRINDING DISC HUB	1	
34	0488	STONE MOUNT PLATE	1	
35		GRINDING DISC STONE ONLY .....	1	CONTACT UNIT SALES DEPT./ACCESSORY ITEM
36		GRINDING DISC ASSY .....	1	CONTACT UNIT SALES DEPT./ACCESSORY ITEM
37#	10968	THRUST BEARING KIT .....	1	INCLUDES ITEMS W/\$
38		UNIVERSAL COMBO BLADE	3,4	CONTACT UNIT SALES DEPT./ACCESSORY ITEM
39		ENDURO UNIVERSAL COMBO BLADE .....	3,4	CONTACT UNIT SALES DEPT./ACCESSORY ITEM
40		UNIVERSAL FINISH BLADE .....	3,4	CONTACT UNIT SALES DEPT./ACCESSORY ITEM
40		ENDURO UNIVERSAL FINISH BLADE .....	3,4	CONTACT UNIT SALES DEPT./ACCESSORY ITEM
41		UNIVERSAL MOUNTING BAR .....	3,4	CONTACT UNIT SALES DEPT./ACCESSORY ITEM
42		SNAP PIN 1/4"X1.3/4" .....	6,8	CONTACT UNIT SALES DEPT./ACCESSORY ITEM
43*	1940	GUARD RING DECAL	1	
44	0166A	LOCK WASHER 3/8"	3,4	
45	1489	SPIDER PLATE ASSY 16 1/2" ARM (B-3 MODEL)		
45	1490	SPIDER PLATE ASSY 16 1/2" ARM (B-4 MODEL)		
46		FIELD TROWEL ARM ADJUSTER ASSY .....	1	CONTACT UNIT SALES DEPT./ACCESSORY ITEM
47		FLOAT DISC 24" DIA .....	1	CONTACT UNIT SALES DEPT./ACCESSORY ITEM
48	1723	MALE R.H. ROD END 5/16"	3,4	
49		FLOAT DISC .....	1	CONTACT UNIT SALES DEPT./ACCESSORY ITEM
50		FLOAT DISC LATCH PIN .....	4	CONTACT UNIT SALES DEPT./ACCESSORY ITEM

# B-SERIES TROWEL — GEARBOX AND ENGINE MOUNTS

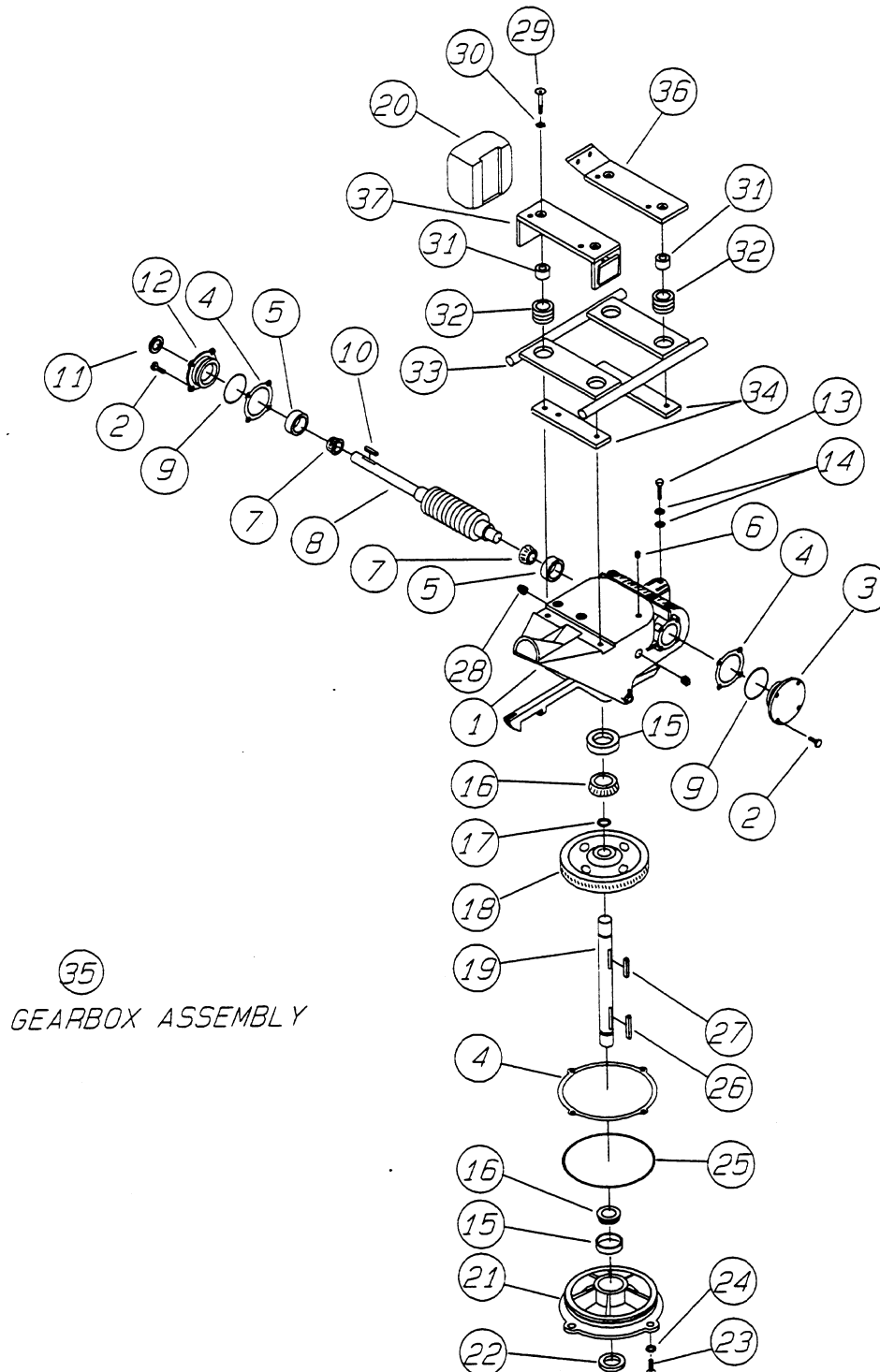

# B-SERIES TROWEL — GEARBOX AND ENGINE MOUNTS

## B-SERIES POWER TROWEL GEARBOX & ENGINE MOUNTS

NO.	PART NO.	PART NAME	QTY.	REMARKS
1%	1131	GEAR CASE	1	
2%	0131A	HHCS 1/4-20X3/4"	8	
3%	1136	END CAP	1	
4	2614	GASKET KIT .....	1	INCLS. ITEMS W/*
5#%	0735A	BEARING CUP	2	
6%	1132	AIR VENT	1	
7#%	0735	BEARING CONE	2	
8%	1851	WORM & COUNTER SHAFT	1	
9*%	2308	O-RING	2	
10	0627	SQ. KEY 3/16X3/16X1.1/4"	1	
11%	0753	OIL SEAL	1	
12%	1133	FLANGE	1	
13	0655	HHCS 5/16-18X3/4 ASSY	1	
14	0300B	FLAT WASHER 5/16" ASSY	1	
15#%	0232A	BEARING CUP	2	
16#%	0232	BEARING CONE	2	
17%	1138	RETAINING RING	1	
18%	1140	BRONZE GEAR 1 1/8 38 TEETH	1	
19%	2440	MAINSHAFT	1	
20%	1810	WEIGHT	2	
21%	1145	COVER PLATE	1	
22*%	0254	OIL SEAL	1	
23%	1146	FHSCS 5/16-18X1"	4	
24%	10235	EXT. SHKP. WASHER 5/16"	4	
25*%	1143	SEAL RING	1	
26	1238	WOODRUFF KEY#25 ASSY	1	
27%	1139	WOODRUFF KEY#21	1	
28%	0121A	SQUARE HEAD PIPE PLUG 3/8"	1	
29	1481	FHCS 3/8-16X1.3/4" (ELECTRIC)	4	
30	1480	C'SINK SHKP WASHER 3/8"	4	
30	0166A	LOCK WASHER 3/8" (ELECTRIC)	4	
31	1245	SPACER	4	
32	1247	GROMMET (STATIONARY RING ONLY)	4	
33	2273	STATIONARY GUARD RING .....	1	REPLACES 1244
34	1816	PLATE	2	
35	1130	GEARBOX ASSY .....	1	INCLS. ITEMS W/%
36	1955	FRONT ENGINE MOUNT (ELECTRIC)	1	
36	1965	FRONT ENGINE MOUNT (ROBIN 7.5 H.P.)	1	
36	1958	FRONT ENGINE MOUNT (HONDA 8 H.P.)	1	
36	1956	FRONT ENGINE MOUNT (B & S 8H.P.)	1	
37	1943	REAR ENGINE MOUNT (ELECTRIC)	1	
37	1964	REAR ENGINE MOUNT (ROBIN & HONDA)	1	
37	1961	REAR ENGINE MOUNT (B & S 8 H.P.)	1	
#	2616	BEARING REPLACEMENT KIT .....	1	INCLS ALL ITEMS W/#
	10139	GEAR BOX OIL (22 OZ.)		

# B-SERIES TROWEL — ENGINES, 5 HP B&S, 6.0 HP ROBIN, 5.5 HP HONDA

ENGINES, 5 H.P. B&S, 6.0 H.P. ROBIN, 5.5 H.P. HONDA ASSY.

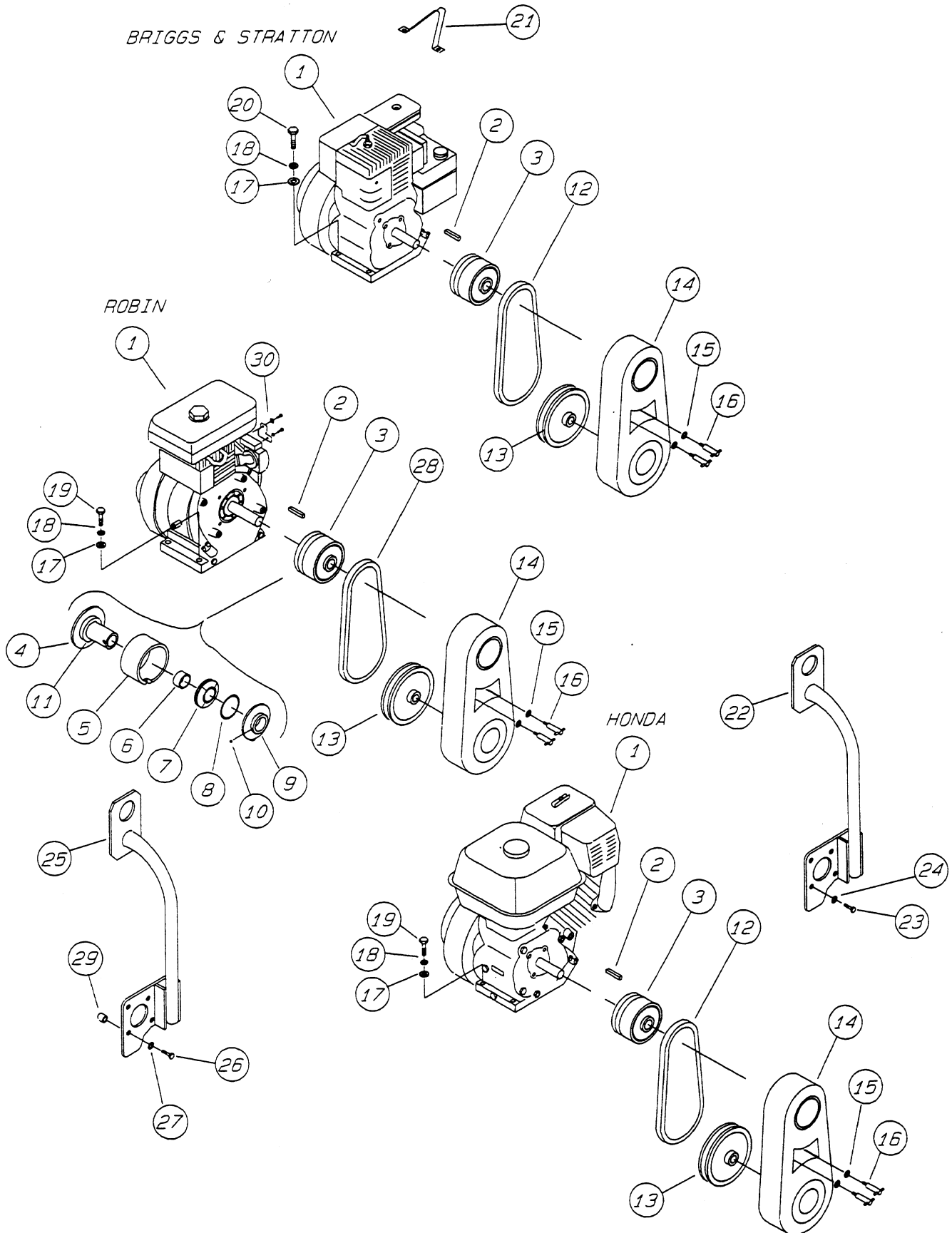

# B-SERIES TROWEL — ENGINES, 5 HP B&S, 6.0 HP ROBIN, 5.5 HP HONDA

ENGINES, 5 H.P. B&S, 6.0 H.P. ROBIN, 5.5 H.P. HONDA ASSY.

<u>NO.</u>	<u>PART NO.</u>	<u>PART NAME</u>	<u>QTY.</u>	<u>REMARKS</u>
1	1256	ENGINE 6.0 HP ROBIN	1	
1	GX240K1QA2	ENGINE 5.5 HP HONDA	1	
1	1242	ENGINE 5 HP BRIGS & STRATTON	1	
2	0310	SQUARE KEY 1/4X1/4X1.1/2"	1	
3	0250	AUTOMATIC CLUTCH ASM 1" BORE .....	1	..... INCLS. ALL ITEMS W/*
4*	0252	SPINDLE 1" BORE	1	
5*	0251	CLUTCH HOUSING DRUM	1	
6*	0458	CLUTCH HOUSING DRUM BUSHING	1	
7*	0454	WEIGHT SET (INCLUDES 4 WEIGHT)	1	
8*	0855	SPRING	1	
9*	0253	CLUTCH EXPANSION PLATE	1	
10*	0457	HSSS 3/8-24X1/2"	1	
11*	0456	BELT RUNNER (BEARING)	1	
12	0261	BELT (A31)(HONDA,B&S)	1	
13	1127	PULLEY	1	
14	1335	BELT GUARD	1	
15	0181B	LOCK WASHER 1/4"	2	
16	2577	T-BOLT 1/4-20	2	
17	0300B	FLAT WASHER 5/16"	4	
18	0161C	LOCK WASHER 5/16"	4	
19	10181	HHCS 5/16-24X1.1/4"	4	
20	1391	HHCS 5/16-24X1.1/2"	4	
21		LIFT STRAP .....	1	..... CONTACT UNIT SALES DEPT./ACCESSORY ITEM
22		LIFTING BALE ASSY .....	1	..... CONTACT UNIT SALES DEPT./ACCESSORY ITEM
23	10229	HHCS 5/16-24X1"	4	
24	0161C	LOCK WASHER 5/16"	4	
25		LIFTING BALE ASSY .....	1	..... CONTACT UNIT SALES DEPT. /ACCESSORY ITEM
26	0205	HHCS 3/8-16X1"	3	
26	1394	FHSCS 3/8-16X1"	1	
27	0166A	LOCK WASHER 3/8"	3	
28	1521	BELT (A30)(ROBIN)	1	
29	1897	SPACER (LIFT BALE OPTION)(ROBIN)	4	
30	2743	THROTTLE BRACKET(ROBIN)	1	

# B-SERIES TROWEL — HAND CLUTCH — S.N. LJ41888 AND BELOW

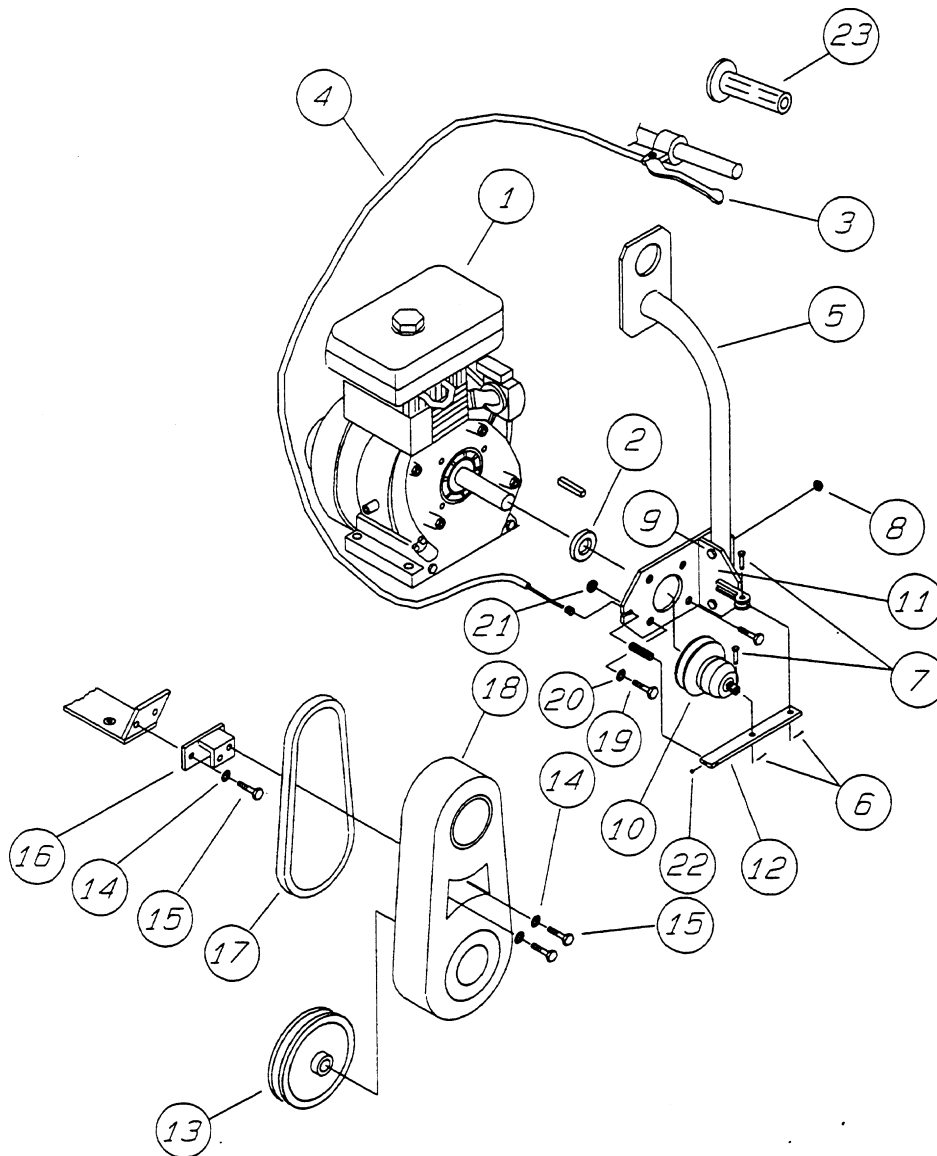

*S. N. LJ41888 AND BELOW*

# B-SERIES TROWEL — HAND CLUTCH — S.N. LJ41888 AND BELOW

B-SERIES POWER TROWEL  
HAND CLUTCH - S/N LJ41888 AND BELOW

<u>NO.</u>	<u>PART NO.</u>	<u>PART NAME</u>	<u>QTY.</u>	<u>REMARKS</u>
1	GX24OK1QA2	ENGINE 8HP HONDA	1	
1	1256	ENGINE 7.5HP ROBIN	1	
2	2834	SPACER (ROBIN)	1	
3	1512	HAND CLUTCH HAND LEVER	1	
4	10075	HAND CLUTCH CABLE ASSY	1	
5		LIFTING BALE ASSY .....	1	..... CONTACT UNIT SALES DEPT./ACCESSORY ITEM
6	5117	COTTER PIN 1/16"X1/2"	2	
7	5133	CLEVIS PIN 1/4"X7/8"	2	
8	1063	LOCK NUT 3/8-24	2	
9	0478	HHCS 3/8-24X2.1/4"	2	
10	2806	HAND CLUTCH 1" BORE	1	
11	10076	LIFT BRACKET PLATE (HONDA)	1	
11	10137	LIFT BRACKET PLATE (ROBIN)	1	
12	10089	CLUTCH ARM	1	
13	0740	PULLEY (HONDA)	1	
13	2842	PULLEY (ROBIN)	1	
14	0181B	LOCK WASHER 1/4"	4	
15	4514	HHCS 1/4-20X5/8"	4	
16	2861	BELT GUARD MOUNT (HONDA)	1	
16	2862	BELT GUARD MOUNT (ROBIN)	1	
17	1521	BELT (A30)(HONDA)	1	
17	0260	BELT (A30)(ROBIN)	1	
18	2492	BELT GUARD	1	
19	0205	HHCS 3/8-16X1" (ROBIN)	4	
19	1605	HHCS M8-1.25X25MM (HONDA)	4	
20	0166A	LOCK WASHER 3/8" (ROBIN)	4	
20	0161C	LOCK WASHER 5/16" (HONDA)	4	
21	1897	SPACER (ROBIN)	4	
22	10450	SHSS 10-32X1/4"	1	
23	2267	GRIP	1	

# B-SERIES TROWEL — HAND CLUTCH — S.N. LJ41889 AND ABOVE

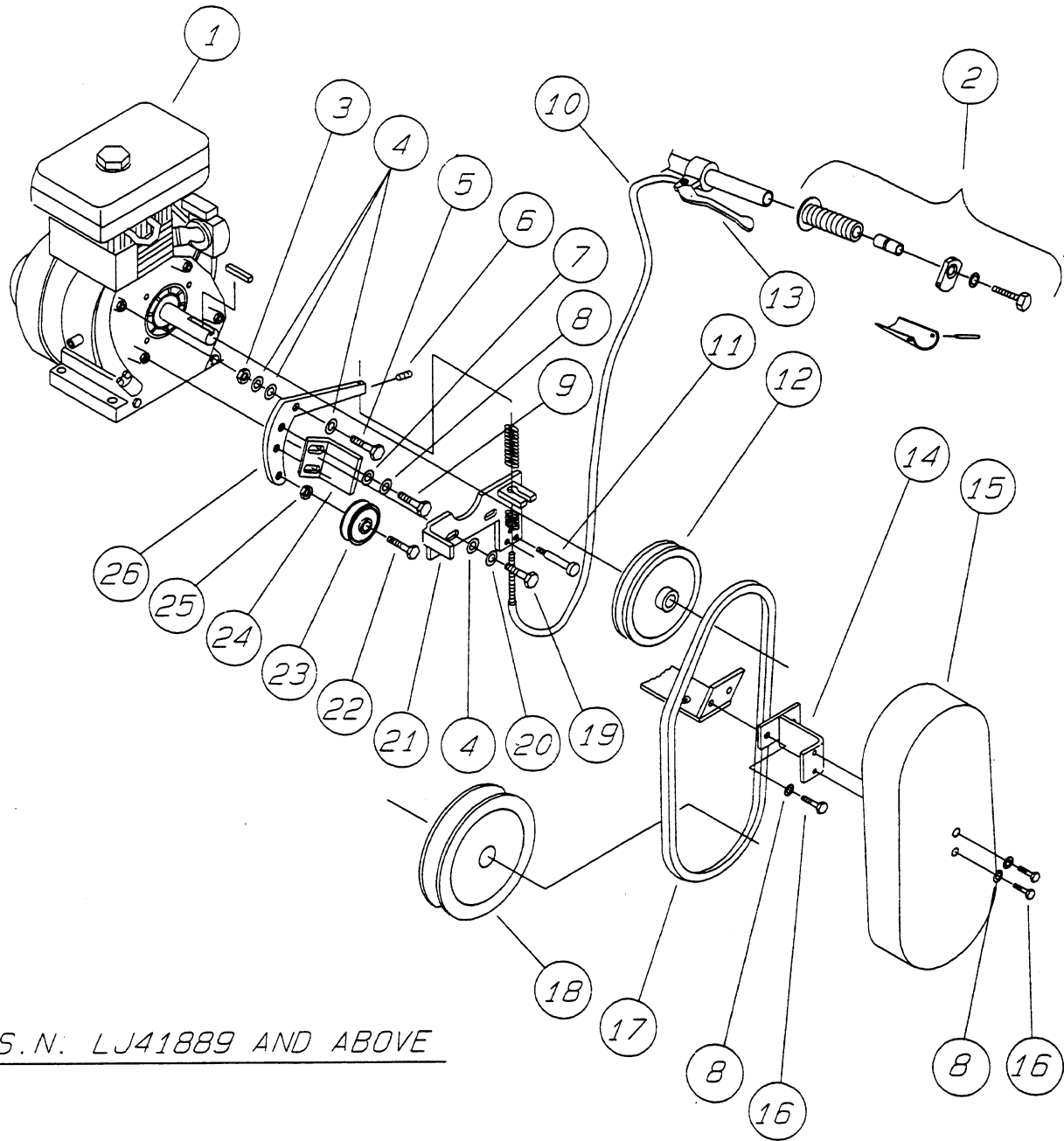

S.N. LJ41889 AND ABOVE



# B-SERIES TROWEL — HAND CLUTCH — S.N. LJ41889 AND ABOVE

B-SERIES POWER TROWEL  
HAND CLUTCH — S.N. LJ41889 AND ABOVE

NO.	PART NO.	PART NAME	QTY.	REMARKS
1	GX24OK1QA2	ENGINE 8HP HONDA	1	
1	1256	ENGINE 7.5HP ROBIN	1	
2	10036	CLUTCH ASSIST HANDLE ASSY	1	
3	6014C	HEX FINISH NUT 5/16-24	1	
4	0300B	FLAT WASHER 5/16"	5	
5	1391	HHCS 5/16-24X1.1/2"	1	
6	10450	SHSS 10-32X1/4"	1	
8	0181B	LOCK WASHER 1/4"	6	
9	1579	HHCS 1/4-20 .....	X 1/2" .....	2
10	10936	HAND CLUTCH CABLE ASSY	1	
11	10971	SHOULDER BOLT 5/16X1.1/2"	1	
12	2469	PULLEY,ENGINE	1	
13	1512	HAND CLUTCH CONTROL LEVER	1	
14	10831	BELT GUARD MOUNT	1	
15	10833	BELT GUARD	1	
16	0730	HHCS 1/4-20X1"	4	
17	0262	BELT,(A33)(HONDA)	1	
17	0261	BELT,(A31)(ROBIN)	1	
18	1127	PULLEY,DRIVEN(HONDA)	1	
18	2842	PULLEY,DRIVEN(ROBIN)	1	
19	10229	HHCS 5/16-24X1"	2	
20	0161C	LOCK WASHER 5/16"	2	
21	10898	CLUTCH BRKT.	1	
22	9154	HHCS 3/5-16X1.3/4"	1	
23	10935	PULLEY,IDLER	1	
24	10740	BELT TENSIONING SHOE	1	
25	1876	HEX JAM NUT 3/8-16	1	
26	10822	CLUTCH IDLER LEVER	1	

**PAYMENT TERMS**

Terms of payment for parts are net 10 days.

**FREIGHT POLICY**

All parts orders will be shipped collect or prepaid with the charges added to the invoice. All shipments are F.O.B. point of origin. Multiquip's responsibility ceases when a signed manifest has been obtained from the carrier, and any claim for shortage or damage must be settled between the consignee and the carrier.

**MINIMUM ORDER**

The minimum charge for orders from Multiquip is \$15.00 net. Customers will be asked for instructions regarding handling of orders not meeting this requirement.

**RETURNED GOODS POLICY**

Return shipments will be accepted and credit will be allowed, subject to the following provisions:

1. A Returned Material Authorization must be approved by Multiquip prior to shipment.
2. To obtain a Return Material Authorization, a list must be provided to Multiquip Parts Sales that defines item numbers, quantities, and descriptions of the items to be returned.
  - a. The parts numbers and descriptions must match the current parts price list.
  - b. The list must be typed or computer generated.
  - c. The list must state the reason(s) for the return.
  - d. The list must reference the sales order(s) or invoice(s) under which the items were originally purchased.
  - e. The list must include the name and phone number of the person requesting the RMA.
3. A copy of the Return Material Authorization must accompany the return shipment.

4. Freight is at the sender's expense. All parts must be returned freight prepaid to Multiquip's designated receiving point.
5. Parts must be in new and resalable condition, in the original Multiquip package (if any), and with Multiquip part numbers clearly marked.
6. The following items are not returnable:
  - a. Obsolete parts. (If an item is listed in the parts price book as being replaced by another item, it is obsolete.)
  - b. Any parts with a limited shelf life (such as gaskets, seals, "O" rings, and other rubber parts) that were purchased more than six months prior to the return date.
  - c. Any line item with an extended dealer net price of less than \$5.00.
  - d. Special order items.
  - e. Electrical components.
  - f. Paint, chemicals, and lubricants.
  - g. Decals and paper products.
  - h. Items purchased in kits.
7. The sender will be notified of any material received that is not acceptable.
8. Such material will be held for 5 working days from notification, pending instructions. If a reply is not received within 5 days, the material will be returned to the sender at his expense.
9. Credit on returned parts will be issued at dealer net price at time of the original purchase, less a 15% restocking charge.
10. In cases where an item is accepted for which the original purchase document can not be determined, the price will be based on the list price that was effective twelve months prior to the RMA date.
11. Credit issued will be applied to future purchases only.

**PRICING AND REBATES**

Prices are subject to change without prior notice. Price changes are effective on a specific date and all orders received on or after that date will be billed at the revised price. Rebates for price declines and added charges for price increases will not be made for stock on hand at the time of any price change.

Multiquip reserves the right to quote and sell direct to Government agencies, and to Original Equipment Manufacturer accounts who use our products as integral parts of their own products.

**SPECIAL EXPEDITING SERVICE**

A \$20.00 to \$50.00 surcharge will be added to the invoice for special handling including bus shipments, insured parcel post or in cases where Multiquip must personally deliver the parts to the carrier.

**LIMITATIONS OF SELLER'S LIABILITY**

Multiquip shall not be liable here under for damages in excess of the purchase price of the item with respect to which damages are claimed, and in no event shall Multiquip be liable for loss of profit or good will or for any other special, consequential or incidental damages.

**LIMITATION OF WARRANTIES**

No warranties, express or implied, are made in connection with the sale of parts or trade accessories nor as to any engine not manufactured by Multiquip. Such warranties made in connection with the sale of new, complete units are made exclusively by a statement of warranty packaged with such units, and Multiquip neither assumes nor authorizes any person to assume for it any other obligation or liability whatever in connection with the sale of its products. A part from such written statement of warranty, there are no warranties, express, implied or statutory, which extend beyond the description of the products on the face hereof.



# PARTS AND OPERATION MANUAL

## **HERE'S HOW TO GET HELP**

*PLEASE HAVE THE MODEL AND SERIAL NUMBER  
ON-HAND WHEN CALLING*

### **PARTS DEPARTMENT**

*800-427-1244 or 310-537-3700*

*FAX: 800-672-7877 or 310-637-3284*

### **SERVICE DEPARTMENT/TECHNICAL ASSISTANCE**

*800-478-1244 or 310-537-3700*

*FAX: 310- 537-4259*

### **WARRANTY DEPARTMENT**

*888-661-4279, or 310-661-4279*

*FAX: 310- 537-1173*

### **MAIN**

*800-421-1244 or 310-537-3700*

*FAX: 310-537-3927*



#### **MULTIQUIP INC.**

POST OFFICE BOX 6254  
CARSON, CA 90749  
310-537-3700 • 800-421-1244  
FAX: 310-537-3927  
E-MAIL: [mq@multiquip.com](mailto:mq@multiquip.com)  
WWW: [multiquip.com](http://multiquip.com)

Atlanta • Boise • Dallas • Houston • Newark  
Quebec, Canada • Manchester, UK • Rio De Janiero, BR • Guadalajara, MX

## Free Manuals Download Website

<http://myh66.com>

<http://usermanuals.us>

<http://www.somanuals.com>

<http://www.4manuals.cc>

<http://www.manual-lib.com>

<http://www.404manual.com>

<http://www.luxmanual.com>

<http://aubethermostatmanual.com>

Golf course search by state

<http://golfingnear.com>

Email search by domain

<http://emailbydomain.com>

Auto manuals search

<http://auto.somanuals.com>

TV manuals search

<http://tv.somanuals.com>