

**S10 series**

**AUTOMATIC BATTERY CHARGERS  
RATINGS TO 10 AMPS**

The S10 is a constant potential, open-chassis battery charger, suitable for use with either 12V DC or 24V DC, lead acid or Ni-Cd systems. Although primarily designed for the diesel generator market, the charger may be configured for use in a wide range of unattended industrial applications where standby power is required at all times.

Each unit consists of a transformer, rectifier and control circuitry. The charger monitors the battery voltage and delivers as much current as the cells require up to the current limited maximum, giving a rapid recovery of charge. Once the battery is fully charged, the charger provides a low trickle charge to maintain the cells for an indefinite period at a pre-set float voltage, without overcharging, plus any additional current required to support a static load.

Also included is a range of on-board fault monitors complete with volt free relay contacts for remote alarm signalling.

**Standard Features**

- Boost function, operated by remote link. Indication by amber LED.
- Adjustable float and boost voltage levels to meet with a range of battery types, static loads and operating conditions. Standard calibrations are:-

BATTERY TYPE		FLOAT VOLTAGE (V DC)	BOOST VOLTAGE (VDC)
12 V	Lead acid (6 cells)	13.6	14.1
	Ni-Cd (9 cells)	12.8	14.0
	Ni-Cd (10 cells)	14.2	15.6
24 V	Lead acid (12 cells)	27.2	28.4
	Ni-Cd (18 cells)	25.6	28.1
	Ni-Cd (20 cells)	28.4	31.2

- Adjustable current limit. Standard versions have a 10 Amp limit, but this may be adjusted downwards where required (e.g. for lower capacity batteries).
- Output short circuit protection.
- Protection against reverse polarity battery connection via fuse and red warning LED.
- 3 alarm monitoring circuits: 'charge fail', 'low battery voltage' and 'high battery voltage', complete with volt-free relay outputs and LED indicators. The low battery voltage alarm features a fixed time delay of approx. 60 secs. to inhibit the signalling of a fault during normal battery loading (e.g. engine cranking).

Electrical connection of the battery, boost and charge monitoring relays is via ¼" blade terminals. The AC supply is connected through separately mounted screw terminals.

**When ordering, please specify:-**

- Product type (S10 series)
- Nominal output voltage (12 or 24 V DC)
- AC supply voltage (240 or 110 V)
- Battery type (Lead-acid, or Ni-Cd and number of cells, or special calibration requirements).



**Product Specification**

<b>Power supply:</b>	
operating voltages	240 V AC or 110 V AC (specify), +/- 10%, 50/60 Hz.
<b>Charging output:</b>	
nominal output voltage	see chart left
voltage stability	+/- 1% of nominal
current limit	1 - 10 Amps, factory set
current stability	+/- 2% of nominal
<b>Relay outputs:</b> (ratings for resistive load)	
charge fail and low battery volts	volt free SPNC contacts
high battery volts	volt free SPNO contacts
all rated 5 A @ 30 V DC	
<b>General:</b>	
operating temperature	-10 to +55 °C
overall dimensions (h x l x d)	185 x 145 x 155 mm
weight	approx. 8.0 Kg
EMC emission/immunity	to EN50081-2/EN50082-2

**Connection**

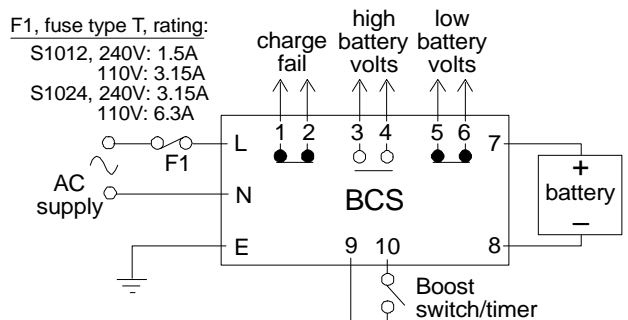

**Dimensions (mm)**

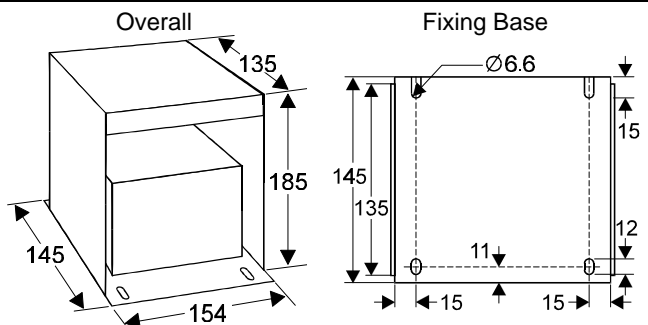

## Free Manuals Download Website

<http://myh66.com>

<http://usermanuals.us>

<http://www.somanuals.com>

<http://www.4manuals.cc>

<http://www.manual-lib.com>

<http://www.404manual.com>

<http://www.luxmanual.com>

<http://aubethermostatmanual.com>

Golf course search by state

<http://golfingnear.com>

Email search by domain

<http://emailbydomain.com>

Auto manuals search

<http://auto.somanuals.com>

TV manuals search

<http://tv.somanuals.com>