



# LLS, LLSB, LLSR, LLSRB Series Models Lead Line Pressure Switches Installation and Operation Instructions

Please read the following information before installing. A visual inspection of this product for damage during shipping is recommended before mounting. It is your responsibility to have a qualified person install the unit and make sure installation conforms to NEC and local codes.

## GENERAL INFORMATION

WARNING

BEFORE BEGINNING INSTALLATION OF THIS MURPHY PRODUCT

- ✓ Disconnect all electrical power to the machine.
- ✓ Make sure the machine cannot operate during installation.
- ✓ Follow all safety warnings of the machine manufacturer.
- ✓ Read and follow all installation instructions.



LLS Series Pressure Switch

### Description

The LLS Series is a pressure switch for applications where viscous liquids could plug the sensing orifice. LLS and LLSB models have a 2 inch NPT male connection which attaches directly into the process line. LLSR and LLSRB models feature a remote sensor connected to the pressure switch by a length of stainless steel capillary and armor. The snap-acting switch is field adjustable. The switch is housed in a hard anodized aluminum enclosure.

Optional for LLSR and LLSRB models is a 1 inch NPT x 1 inch NPT (male) pulsation dampener to minimize damaging pressure pulsation to the switch.

### Specifications

- **Maximum Ambient Temperature:** -10° to +160°F (-23° to +71°C).
- **Maximum Process Temperature:** -40° to +160°F (-40° to +71°C).
- **Temperature Compensation:** The volumetric expansion and contraction of the fill may cause a shift of ±3% to ±5% of the set point.
- **Switch Enclosure:** Aluminum hard anodized (black). NEMA 4, 4x. NEMA 7 and 9 explosion-proof, waterproof and corrosion resistant. Suitable for Class I, Div. 1, Groups A, B, C, D; Class II, Div. 2, Groups E, F, G.

- **Sensor Body:** LLS: CRS steel chromate plated; 2 in. NPT connection.  
LLSB: Thick wall 304 stainless steel sensor 2 in. NPT process connection.  
LLSR: Remote Sensor; Nickel plated steel, stainless steel capillary.  
LLSRB: Remote Sensor; 316 stainless steel housing and capillary.
- **Diaphragm Materials:**  
LLS/LLSB: Ni-SPAN®. LLSR/LLSRB: 316L S. Steel-Teflon\* coated.
- **Snap-switch Ratings:** SPDT (Std.): 15 A @ 125, 250 or 480 VAC  
SPDT (Gold): 100 mA @ 125 VAC; 0.250 A @ 6 VDC  
DPDT (Std.): 11 A @ 125 or 250 VAC  
DPDT (Gold): 100 mA @ 125 VAC; 0.250 A @ 6 VDC
- **Trip Point Adjustment:** Field-adjusted with screwdriver.
- **LLSR/LLSRB Mount:** 4-hole bolt pattern; 1/4 in. (6 mm) dia. bolts.
- **LLS/LLSB Mount:** Direct mount into process (2 in. NPT connection).
- **Shipping Weight:** LLS/LLSB: 4 lbs. 9 oz. (2.25 kg).  
LLSR/LLSRB: 7 lbs. 12 oz. (3.23 kg).
- **Shipping Dimensions:** LLS/LLSB: 10 x 9-1/4 x 5-3/4 in. (254 x 235 x 146 mm).  
LLSR/LLSRB: 15-3/4 x 11 x 5-1/4 in. (400 x 279 x 133 mm).

### Sensor Model Selection Table

Base Model	Switch Adjustment Range		Dead Band Approximate		Max System		Wetted Parts Materials
	psi	kPa/MPa	psi	kPa/MPa	psi	MPa	
LLS	50-450	345 kPa-3.1 MPa	5-45	34 kPa-310 kPa	1500	10.3	CRS steel sensor -chromate plated (yellow) Ni-SPAN® diaphragm.
	100-1750	689 kPa-12 MPa	15-100	103 kPa-689 kPa	2500	17.2	
	200-2500	13.8 MPa-17.2 MPa	20-150	137 kPa-1.03 MPa	3000	20.6	
	400-4000	2.8 MPa-27.5 MPa	75-450	517 kPa-3.1 MPa	5000	34.4	
LLSB	50-450	345 kPa-3.1 MPa	5-45	34 kPa-310 kPa	1500	10.3	Thick wall 304 stainless steel sensor housing; Ni-SPAN® diaphragm. Meets NACE MR-01-75 standard for direct exposure to H <sub>2</sub> S.
	100-1750	689 kPa-12 MPa	15-100	103 kPa-689 kPa	2500	17.2	
	200-2500	13.8 MPa-17.2 MPa	20-150	137 kPa-1.03 MPa	3000	20.6	
	400-4000	2.8 MPa-27.5 MPa	75-450	517 kPa-3.1 MPa	5000	34.4	
LLSR	50-450	345 kPa-3.1 MPa	5-45	34 kPa-310 kPa	1500	10.3	Remote sensor-Nickel plated steel w/ stainless steel capillary; Teflon* coated diaphragm.
	100-1750	689 kPa-12 MPa	15-100	103 kPa-689 kPa	2500	17.2	
	200-2500	13.8 MPa-17.2 MPa	20-100	137 kPa-689 kPa	3000	20.6	
LLSRB	50-450	345 kPa-3.1 MPa	5-45	34 kPa-310 kPa	1500	10.3	Remote sensor-AISI 316 stainless steel housing; stainless steel capillary and armor; AISI 316L stainless steel Teflon* coated diaphragm.
	100-1750	689 kPa-12 MPa	15-100	103 kPa-689 kPa	2500	17.2	
	200-2500	13.8 MPa-17.2 MPa	20-150	137 kPa-1.03 MPa	5000	34.4	
	400-4000	2.8 MPa-27.5 MPa	75-450	517 kPa-3.1 MPa	5000	34.4	

\* Teflon-DuPont Trademark

# DIMENSIONS

## LLS and LLSB Models

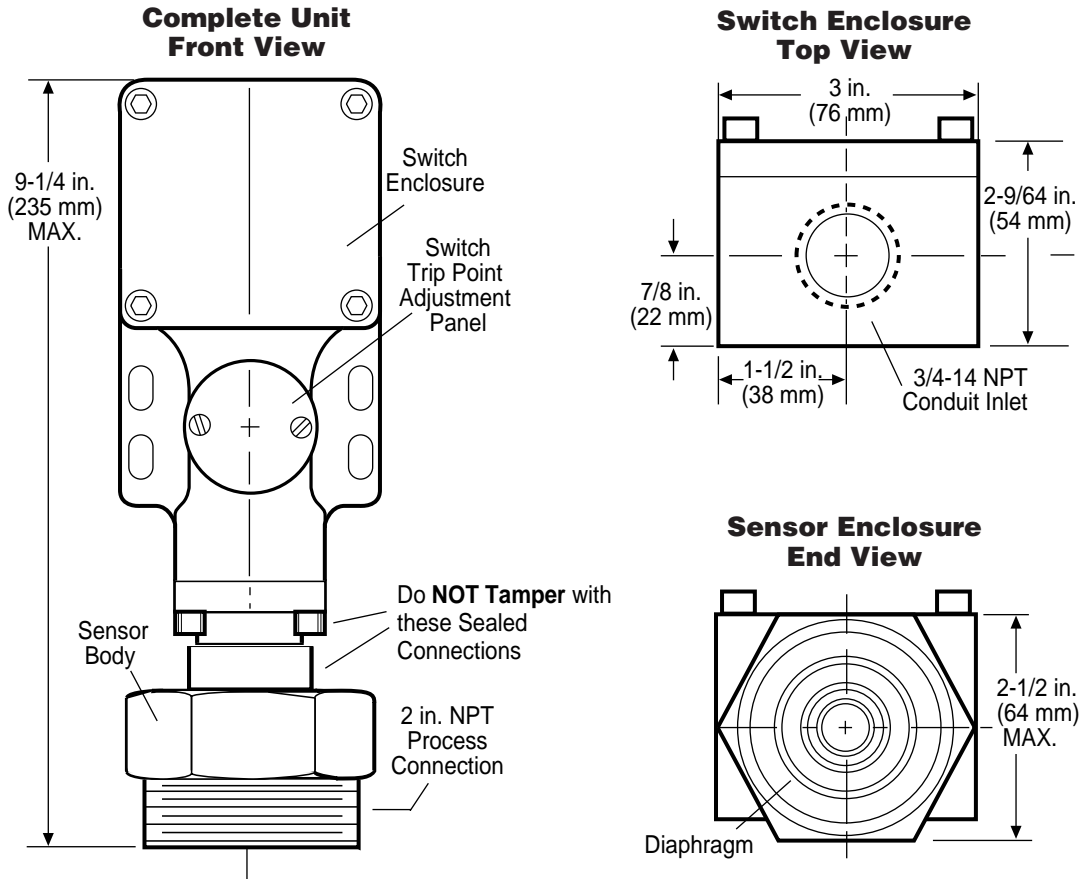

## LLSR and LLSRB Models

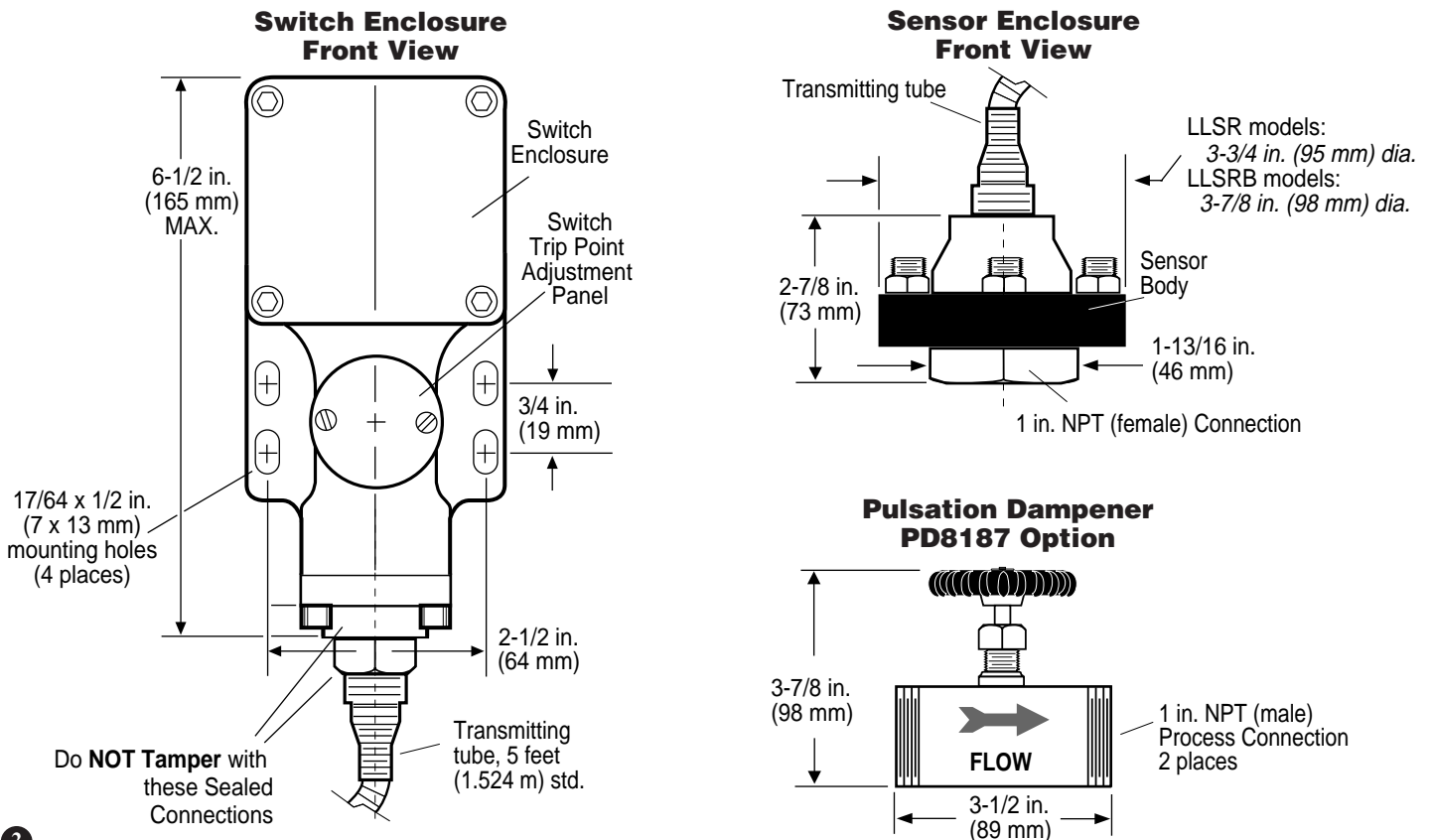

## INSTALLING THE LLS SERIES PRESSURE SWITCH



**WARNING:** PERFORM THE INSTALLATION WITH POWER SOURCE “OFF”. NEVER EXCEED RATED PRESSURE RANGE FOR THE UNIT. USE WRENCH ON SHANK TO TIGHTEN/LOOSEN CONNECTIONS. DO NOT TWIST THE ENCLOSURE WHEN SCREWING THE LLS INTO THE PROCESS – THIS WILL DAMAGE INTERNAL COMPONENTS, FILLED MECHANISM AND THE SEALS. DO NOT OVERTIGHTEN THE UNIT.

### Connecting the LLS and LLSB Series

To install the LLS and LLSB Series, a vertical mounting is recommended.

1. The unit threads directly into a 2 in. 11-1/2 NPT tee on the lead line.



**CAUTION:** DO NOT TAMPER WITH OR BREAK SEALED CONNECTIONS. APPLY PIPE SEALANT TO PROCESS CONNECTION THREADS.

2. Tighten the bottom housing to the lead line tee using **ONLY** the transmitter wrench flats (see **figure 1**).
3. Check for leakage on any of the connections. Make sure that the installation conforms with local and other applicable codes.

**Figure 1**

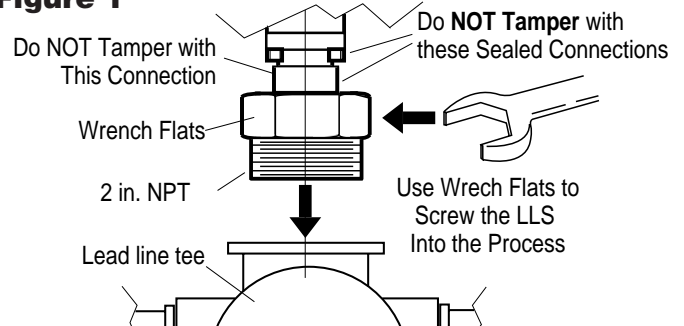

### Connecting the LLSR and LLSRB Series

For mounting the switch enclosure refer to “Dimensions” on page 2.

The following instructions are based on the usage of a PD8187 Pulsation Dampener option shown in **Figure 2** (at right.)

1. Install sensor/pulsation dampener into pressure source connection.



**CAUTION:** THE PD8187 PULSATION DAMPENER IS NOT INTENDED AS A SHUTOFF VALVE. APPLY PIPE SEALANT TO THE THREADS.

2. Loosen the eight housing bolts until the bottom housing is free to turn.



**CAUTION:** WHEN LOOSING THE EIGHT HOUSING BOLTS, MAKE SURE NOT TO UNSCREW THE GREEN DIAPHRAGM CAPSULE.

3. Tighten the bottom housing to the pulsation dampener connection.
4. Tighten the eight housing bolts to 25±3 foot lbs. Stagger the tightening to assure even clamping.
5. Route capillary away from heat source (exhaust manifold). Excess capillary should be carefully coiled and secured (do **NOT** cut it).

**Figure 2**

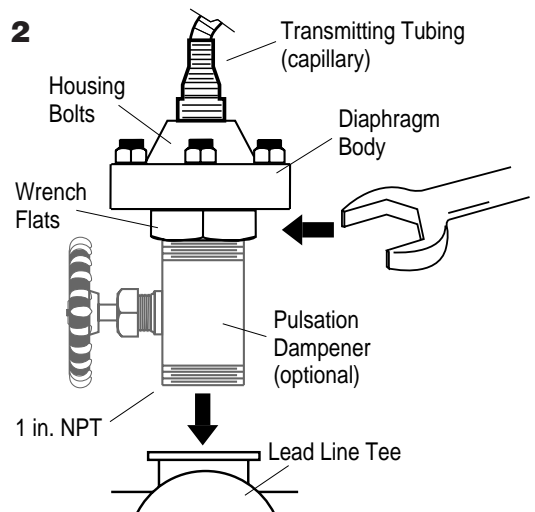

## WIRING THE LLS SERIES PRESSURE SWITCH



**WARNING:** PERFORM THE WIRING OPERATION WITH THE POWER SOURCE “OFF”. MAKE SURE VOLTAGE AND CURRENT REQUIREMENTS ARE WITHIN THE LLS RATINGS. BEFORE WIRING THE UNIT DETERMINE VOLTAGE AND POLARITY FOR THE APPLICATION. IF THE UNIT IS USED IN HAZARDOUS AREAS, MAKE THE AREA SAFE BEFORE REMOVING THE SNAP-SWITCH(ES) COVER.

If switch trip point needs to be adjusted, see page 4.

### LLS Series Hook-up (all models)

To wire the LLS Series, use proper the electrical conduit.

1. A 3/4"-14 NPT inlet connection for conduit installation is provided at the top end of the switch enclosure (see opposite page– “Dimensions” for location).

**NOTE:** The plastic plug (supplied) is to protect the conduit inlet threads and must be removed before wiring the unit.

2. Using a 3/16 in. hex wrench, unscrew the 4 hex-cap screws. Now proceed to remove the square cover to reveal snap-switch(es).
3. To wire the unit, refer to the typical wiring drawing (Figure 3) and to the Schematic (shown at right). Wire the LLS Series switch(es) with 60°/75°C (140°/167°F) insulated wire.
4. A terminal (inside the switch enclosure) is provided for case or equipment grounding, refer to Figure 3 for location.
5. After completing wiring, replace the switch cover and make sure it is tightly secured before applying power to the system.

**Schematic**

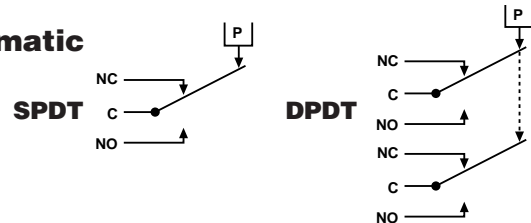

**Figure 3**

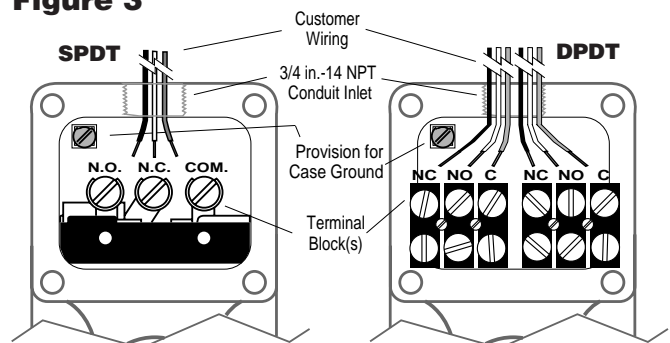

## ADJUSTING THE TRIP POINT

**CAUTION:** REMEMBER THAT THE FIELD-ADJUSTABLE TRIP POINT MAY HAVE BEEN FACTORY SET TO YOUR SPECIFICATIONS. ADJUSTMENT OF THE TRIP POINT VARIES ACCORDINGLY TO THE APPLICATION AND MUST BE PERFORMED BY A QUALIFIED PERSON.

### LLS Series Trip Point Adjustment if necessary (all models)

**NOTICE:** If trip point is not specified, the switch will be set at approximately 50% of full scale. To perform trip point re-adjustments, a test stand with variable pressure source, a test light, and a pressure gauge (such as our OPLG or OPLFG MURPHYGAGE®) may be used.

#### To Reset for Rising Pressure

1. Locate and remove the Switch Trip Point Adjustment cover (round) to reveal the Adjustment Wheel, (see figure 4).

**WARNING:** DO NOT REMOVE SNAP-SWITCH COVER AT THE INSTALLATION SIGHT UNTIL THE AREA IS MADE NON-HAZARDOUS.

2. After area is made non-hazardous, proceed to remove the square cover to reveal the snap-switch(es).
3. Connect test light to (COM) and (N.C.) terminals. The light should turn "ON". Gradually increase the pressure until the light turns "OFF". Observe the trip point pressure reading.
4. With a screwdriver, turn the adjustment wheel to the desired setting. Repeat step 4 until the light turns "OFF" at the desired pressure.

#### To Reset for Falling Pressure

Follow step 1 and step 2 (above), then:

3. Connect test light to (COM) and (N.O.) terminals. The light should stay "OFF". Gradually increase the pressure until the light turns "ON". Observe the trip point pressure reading.
4. With a screwdriver, turn the adjustment wheel to the desired setting. Repeat step 4 until the light turns "OFF" at the desired pressure.

**Replace the adjustment and the switch covers securely.**

Figure 4

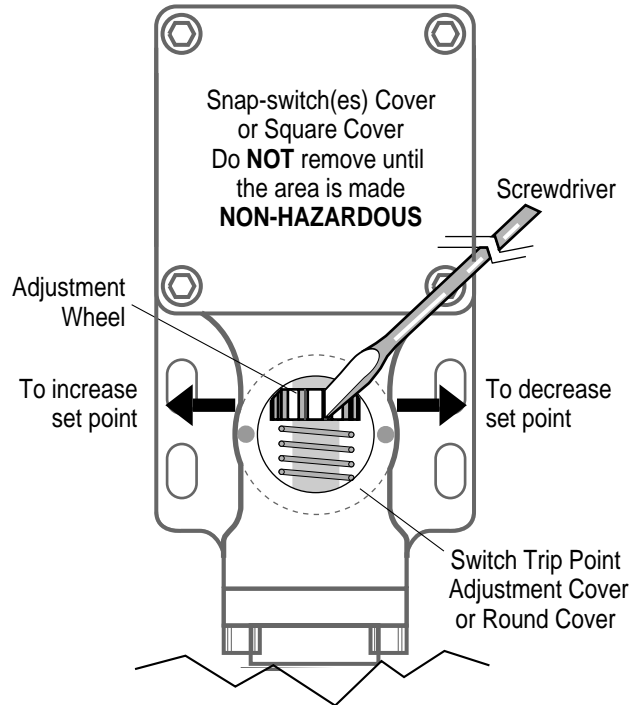

## WARRANTY

A two year limited warranty on materials and workmanship is provided with this Murphy product. Details are available on request and are packed with each unit.

*In order to consistently bring you the highest quality, full featured products, we reserve the right to change our specifications and designs at any time.*



■ **Frank W. Murphy Manufacturer**  
P.O. Box 470248; Tulsa, Oklahoma 74147; USA  
tel. (918) 627-3550 fax (918) 664-6146  
e-mail fwmurphy@ionet.net

■ **Frank W. Murphy Southern Division**  
P.O. Box 1819; Rosenberg, Texas 77471; USA  
tel. (281) 342-0297 fax (281) 341-6006  
e-mail murphysd@intertex.net

■ **Frank W. Murphy, Ltd.**  
Church Rd.; Laverstock, Salisbury SP1 1QZ; U.K.  
tel. +44 1722 410055 fax +44 1722 410088 tlx 477088  
e-mail sales@fwmurphy.co.uk

■ **Frank W. Murphy Pte., Ltd.**  
26 Siglap Drive; Republic of Singapore 456153  
tel. +65 241-3166 fax +65 241-8382  
e-mail fwmsales@fwmurphy.com.sg

■ **Murphok Pty., Ltd.**  
1620 Hume Highway; Campbellfield, Vic 3061; Australia  
tel. +61 3 9358-5555 fax +61 3 9358-5558

■ **Murphy de México, S.A. de C.V.**  
Blvd. Antonio Rocha Cordero 300, Fracción del Aguaje  
San Luis Potosi, S.L.P.; México 78384  
tel. +52-48-206264 fax +52-48-206336  
e-mail murmexsl@sanluis.podernet.com.mx

■ **Murphy Switch of California**  
P.O. Box 900788; Palmdale, California 93590; USA  
tel. (805) 272-4700 fax (805) 947-7570  
e-mail sales@murphyswitch.com

■ **Frank W. Murphy France**  
tel. +33 1 30 762626 fax +33 1 30 763989

Printed in U.S.A.

## Free Manuals Download Website

<http://myh66.com>

<http://usermanuals.us>

<http://www.somanuals.com>

<http://www.4manuals.cc>

<http://www.manual-lib.com>

<http://www.404manual.com>

<http://www.luxmanual.com>

<http://aubethermostatmanual.com>

Golf course search by state

<http://golfingnear.com>

Email search by domain

<http://emailbydomain.com>

Auto manuals search

<http://auto.somanuals.com>

TV manuals search

<http://tv.somanuals.com>