

**MUSTANG SURVIVAL**  
**INFLATABLE VEST**  
**WITH LIFT™**



# Owner's Manual

## **MD0450 Inflatable Vest with LIFT™**

Hydrostatic Inflation Model - Manual with Automatic Backup  
Recreational: USCG Approved Type V with performance equivalent  
to a Type III PFD

## **MA1900 Sailing Harness**

For use with model MD0450 only

## **MD0451 Inflatable PFD**

Hydrostatic Inflation Model - Manual with Automatic Backup  
Uninspected Commercial Vessels: USCG Approved Type V

SecureZIP™ US Patent No. 6,832,415 and Patents Pending





## CONTENTS

Page	1 Approval Conditions and Carriage Requirements
	3 Note to Uninspected Commercial Vessel Operators
	3 Why are PFDs Required Safety Equipment?
	3 What is an Inflatable PFD?
	4 Instructions for Use
	5 Uninspected Commercial Vessel Use
	5 Component Inspection Instructions
	6 Readiness Checklist
	6 Donning Instructions
	8 Inflation
	10 In-water Adjustments
	11 Special Considerations for Automatic Devices
	11 Deflation
	12 Usage Below Freezing
	13 Re-arming Your PFD
	17 Repacking
	22 MA1900 Sailing Harness
	23 Inserting the MA1900 Sailing Harness
	27 Adjusting the MA1900 Sailing Harness
	27 Is Your PFD in Good and Serviceable Condition?
	28 Care and Maintenance Instructions
	30 Cleaning and Storing
	30 How and Why to Test Your PFD
	31 How Do You Test Your PFD Using the Automatic Inflator?
	31 How Do You Test Your PFD Using the Manual Inflator?
	32 How Do You Test Your PFD Using the Oral Inflator?
	33 Wear Your PFD
	34 Hypothermia
	35 Each of These Devices is Intended to Help You Save Your Life
	36 Safety Accessories
	36 Additional Information
	36 Do Not Attach PFDs to Your Boat
	37 Airline Operator Policy on Carriage of Inflatable PFDs

## **APPROVAL CONDITIONS AND CARRIAGE REQUIREMENTS**

Models MD0450 and MD0451 Inflatable Vests with LIFT™ are USCG approved as Type V PFDs for use as a substitute for Type III PFDs only when used in accordance with the owner's manual.

**The MD0450 and MD0451 take several exceptions to the inflatable PFD standards and therefore require user involvement to ensure a level of safety equal to other inflatable PFDs. The approval conditions let users overcome the design traits that would otherwise prevent approval.** These are Type V inflatable PFDs because (1) performance is achieved by avoidance of mouth immersion in waves in place of face-up turning ability, (2) when the harness is provided (MD0450 only), it can cause injury (OR DEATH) if not properly used, (3) requires secondary donning after inflation. **Knowledgeable users increase their safety significantly by wearing and using these PFDs as prescribed in this owner's manual.**

**Recreational** - Model MD0450 has Type III performance and is approved as a Type V PFD because it has attachments for a sailing harness that can cause injury if not properly used. A separate section titled "SAILING HARNESS" (p. 22) discusses requirements and features on the MD0450 only. USCG approval does not apply to the sailing harness because some of the risks associated with its use have not been evaluated.

**Commercial** - The MD0451 is approved by the U.S. Coast Guard for use as a Type V Personal Flotation Device (PFD) approved ONLY WHEN WORN for use on uninspected commercial vessels less than 40 feet in length not carrying passengers for hire as a substitute for a Type III PFD when used in accordance with this owner's manual.

---

**NOTE: MD0450 is not USCG approved for Uninspected Commercial Vessels.**

---

Conditions for Type V Approval in commercial applications:

1. The MD0451 must be worn before getting underway and whenever

above deck and not within an enclosed space to meet the carriage requirement.

2. The operator of an uninspected commercial vessel is responsible for servicing and maintaining the MD0451 in good serviceable condition in accordance with this owner's manual. See Care and Maintenance Instructions (p. 28) for servicing information.
3. The operator of an uninspected commercial vessel is responsible for providing each person onboard with the safety information required for use of the MD0451. See page 3 for information.

**General** - When fully inflated, this Inflatable PFD will provide Type III in-water performance. This Inflatable PFD will turn most wearers from a face down to a face up position and provide support suitable for offshore conditions. See page 13 for re-arming instructions.

Inflatable PFDs are not approved for water skiing or other high-speed activities. This Inflatable PFD was designed to be more comfortable and less restrictive to wear than inherently buoyant PFDs. When worn, used and serviced according to this owner's manual, this PFD can greatly increase your chances of survival in the water. **Not recommended for non-swimmers or weak swimmers.** Users of inflatable PFDs must be at least 16 years old.

Federal regulations in 33 CFR 175-1993 require you to carry Coast Guard approved personal flotation devices (PFDs) legibly marked with the Coast Guard approval number which are in good and serviceable condition and are the correct size for each person on board. To be considered serviceable, this PFD shall not exhibit deterioration that could diminish its performance such as broken or deformed hardware, detached webbing, rotted structural components, air leaks, or nonfunctional oral inflation tube. Unless worn inflated, this PFD must also be properly armed with a full CO<sub>2</sub> cylinder, inflation system status indicator, and a manual inflation pull-tab accessible outside the user's right front panel cover (Fig. 1). The chest buckle, on the Inflatable Vest with LIFT™, must be fastened after inflation.

## NOTE TO UNINSPECTED COMMERCIAL VESSEL OPERATORS

The operator of the vessel is required to provide the following user information to each person on board.

Inflatable PFDs will not provide any buoyancy without being inflated. Follow these instructions to be sure your PFD is armed and donned correctly, and that you understand how to inflate the device.

Basic visual inspection for readiness, see p. 6

Inflation system status check, see p. 6

Donning, see p. 6

Inflation, see p. 8

## WHY ARE PFDs REQUIRED SAFETY EQUIPMENT?

Drownings are the leading cause of fatalities involving recreational and commercial vessels. A PFD provides flotation to help keep your head above water, help you to stay face up in the water, and increase your chances for survival and rescue. Most adults only need an extra 7 to 12 lb (3.2 to 5.5 kg) of flotation to keep their heads above water. The proper size PFD will properly support the weight of the wearer.

Since this Inflatable PFD does not have inherent buoyancy, it provides flotation only when inflated. Familiarize yourself with the use of this Inflatable PFD so you know what to do in an emergency.

## WHAT IS AN INFLATABLE PFD?

Congratulations on the purchase of your Inflatable Vest with Patent Pending LIFT™ [Life-saving Inflatable Flotation Technology]. LIFT™ is different from all other inflatable PFD's. In general, inflatable PFD's are designed to suspend a user's head above water to prevent drowning. The Inflatable Vest with LIFT™ provides freeboard that far exceeds the minimal 3" generally provided. LIFT™ elevates you to an upright safe

position and delivers up to 9" of freeboard, the highest ever seen in a PFD, keeping your mouth high above the water line to minimize the risk of mouth immersions. Not only is LIFT™ one of the world's best performing PFD's in wave conditions, but it's comfortable too. Light and ergonomically designed – you can't even tell you're wearing it until you need it.

While traditional PFDs are inherently buoyant, inflatable PFDs like the Inflatable Vest with LIFT™ rely entirely upon inflation for buoyancy. Uninflated, the Inflatable Vest with LIFT™ is comfortable and can be inflated at any time with a 38-gram CO<sub>2</sub> gas cylinder. The Inflatable Vest with LIFT™ is designed to meet the demands of a full protection PFD offering maximum mobility with minimum bulk. The Inflatable Vest with LIFT™ can be inflated either automatically during immersion, manually by jerking a pull-tab, or by mouth. It is imperative that you familiarize yourself with the procedures outlined in INSTRUCTIONS FOR USE (p. 4).

## INSTRUCTIONS FOR USE

This manual supplies instructional, maintenance and safety information for model MD0450 unless specified otherwise. The model number is listed on the label.

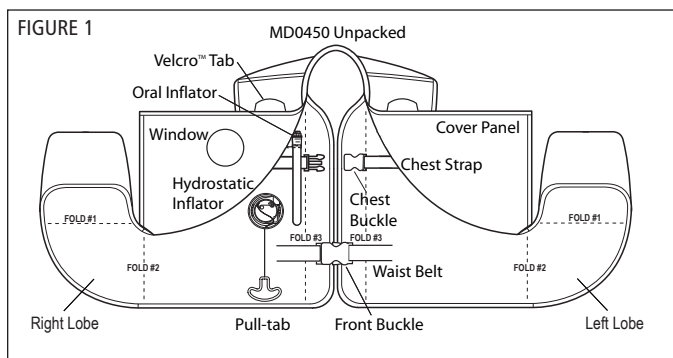
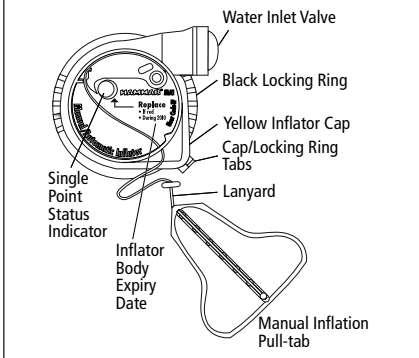


FIGURE 2 Hydrostatic Inflator Cap



## Uninspected Commercial Vessel Use

This Inflatable PFD is not approved for "hot work" and care must be taken to avoid damage from abrasion and sharp objects.

## Component Inspection Instructions

- 1) Examine the single point indicator through the window panel. Ensure the single point indicator is green. If the single point indicator is red, the mechanism has been fired or is incorrectly fitted (Fig. 2). See RE-ARMING YOUR PFD (p. 13).

---

**NOTE: The single point indicator must be green before proceeding.**

---

- 2) Open the cover at wearer's right-hand side of the chest and lay the device flat.
- 3) Ensure the oral-inflation dust cap is in the stowed position (Fig. 22).
- 4) Ensure the single point indicator is green and the pull-tab lanyard is hanging on the outside; secure the zippers on the Inflatable Vest with LIFT™ (see Repacking, p. 17).
- 5) Ensure the date on the inflator is not five years or older (Fig. 2). If it



is, replace the inflator (see Re-arming Your PFD, p. 13).

## Readiness Checklist

Check your Inflatable Vest with LIFT™ and ensure all of the checkpoints listed below are true before each use.

- Single point indicator is green.
- Ensure the current date is not past the date on the inflator. If it is, replace the inflator (see Re-arming Your PFD, p. 13).
- All zippers, Velcro™ and waist buckle are securely fastened.
- Inflatable Vest with LIFT™ is not twisted.
- Harness, if provided, the shoulder straps are through the shoulder strap harness closures and no straps are twisted (p. 22).
- Oral-inflation dust cap is in the stowed position (Fig. 22).
- Ensure the inflation pull-tab is hanging on the outside (Fig. 33).
- No rips, tears or holes; all seams are securely sewn; and the fabric, straps and hardware are still strong.

Your Inflatable Vest with LIFT™ is ready for use if all boxes are checked.

---

**NOTE: Contact your Mustang Dealer if you have any concerns about the readiness of your Inflatable Vest with LIFT™.**

---

## Donning Instructions

It is important that the PFD is properly adjusted to fit the person wearing it. An incorrect fit or improper fastening of attachments could reduce its effectiveness.

- 1) Put the Inflatable Vest with LIFT™ on just like a jacket (Fig. 3). If the Inflatable Vest with LIFT™ is already inflated prior to donning, it may be excessively tight while donning. If so, expel some air by depressing the oral tube valve, don the Inflatable Vest with LIFT™, and refill Inflatable Vest with LIFT™ by mouth using the oral tube.

When used with harness MA1900, the bottom of the belt must

always be worn at least 2 inches (5 cm) above the lowest rib and adjusted to a tight personal fit.

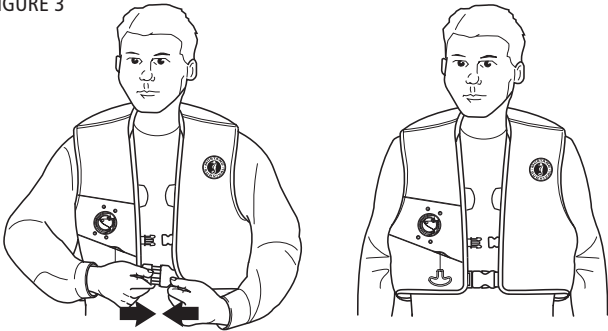
- 2) Fasten the front waist belt buckle (Fig 3). Adjust the waist belt to a secure fit using the front adjuster on the belt.

---

**NOTE: Do not wear the Inflatable Vest with LIFT™ under other clothing or harness systems as the inflation could be restricted and you could be injured.**

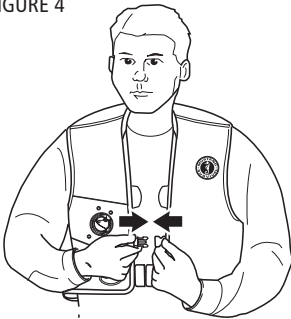
---

FIGURE 3



- 3) Fasten the middle buckle (Fig. 4). Adjust the middle belt to a secure fit using the front adjuster on the belt.

FIGURE 4

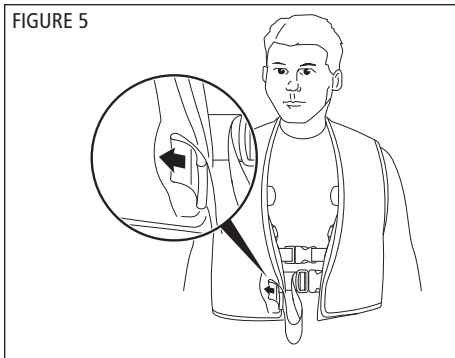


---

**IMPORTANT: Ensure the chest buckle is fastened, when inflated (Fig. 4).**

---

- 4) Feed the loose end of the waist belt into the belt opening in the storage pocket (Fig. 5).



## Inflation

It is recommended that the following procedures be followed to inflate your Inflatable Vest with LIFT™.

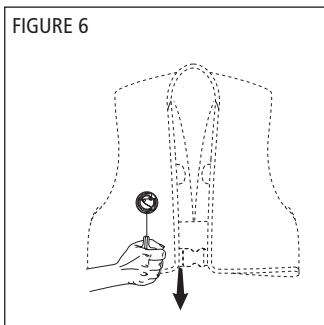
### Manual Inflation

- 1) Activate the inflation system by grasping the inflation pull-tab at the bottom right and jerk firmly downward. The PFD should fully inflate within 5 seconds (Fig. 6).

---

**NOTE: Deflation may occur if the CO<sub>2</sub> cylinder is removed while the Inflatable Vest with LIFT™ is inflated.**

---

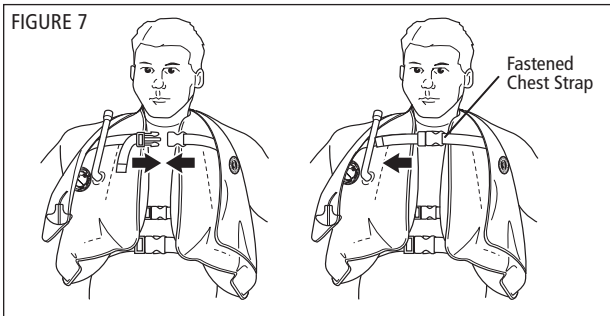


2) Fasten the chest straps (Fig. 7) and adjust to a snug fit.

---

**Important: Ensure the chest buckle is fastened, when inflated.**

---



### Automatic Backup Inflation

Inflation will occur automatically within 5 seconds after the inflator is immersed in water. The water-sensing element will disintegrate, triggering a spring-loaded plunger, which punctures the CO<sub>2</sub> cylinder inflating the Inflatable Vest with LIFT™ (Fig. 7).

---

**NOTE: When inflated, the carbon dioxide (CO<sub>2</sub> gas) used to inflate PFDs will slowly escape through the cell over time. A slight reduction of pressure will be observed after several hours of inflation. Topping up by oral inflation may be required in the event of prolonged immersion.**

---

### Oral Inflation

Properly armed and inspected Inflatable Vest with LIFT™ PFDs will inflate when manually or automatically activated. However, you can fully inflate the PFD by mouth (Fig. 8) should inflation not occur, or if you are in a non-emergency situation.

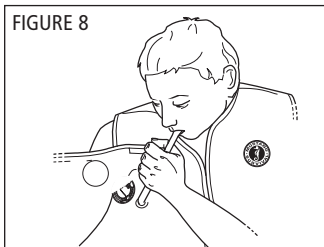
To orally inflate the PFD, first locate the oral inflation tube by opening the wearer's right front panel cover of the PFD. Then remove the dust cap from the end of the oral tube and blow into the tube until the PFD is fully inflated.

It may be necessary to manually release the Velcro™ tabs for full inflation because oral inflation may not provide sufficient pressure to open the tabs.

---

**WARNING: CO<sub>2</sub> inflation could over-pressurize and damage your PFD if already orally inflated.**

---

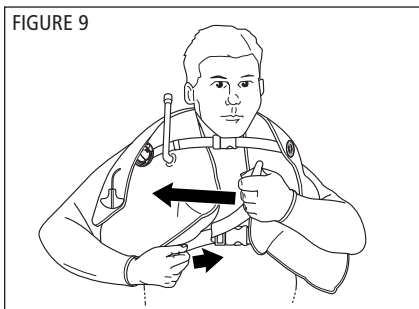


### **In-water Adjustments**

Follow these instructions to adjust the waist belt, when wearing the Inflatable Vest with LIFT™ in the water.

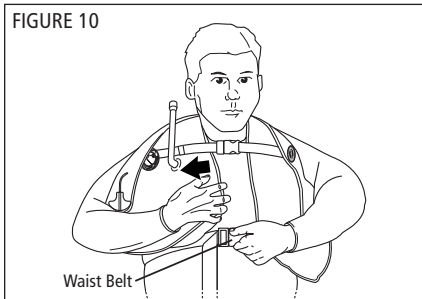
To tighten:

- a. Grasp the loose end with the left hand. Pull the webbing to your right side (away from the buckle) (Fig. 9).
- b. Simultaneously grasp the waist belt along the body with the right hand (approximately 6 inches to the right of the buckle), and feed the webbing into the buckle.



To loosen:

- a. Simultaneously grasp and hold the waist belt with the left hand as you grasp the lobe on the right side with the right hand and pull away from the center (Fig. 10).



### Special Considerations for Automatic Devices

The PFD might not be armed when needed, either knowingly or unknowingly. Premature automatic inflation causes several risks that you must address to avoid drowning. Much less common but also important are:

- 1) Double inflation (CO<sub>2</sub> cylinder inflation after full oral inflation) could damage the PFD,
  - 2) Inflation when stored in a tight space could damage the PFD, and
  - 3) The PFD could inflate when you are in an awkward place or position.
- If this PFD should inflate, a re-arm kit (MA7218), with a valid install-by-date, is required to re-arm the device.

---

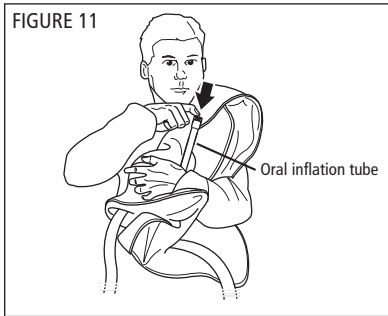
**IMPORTANT: The PFD should be re-armed according to the Re-arming Your PFD instructions (p. 13).**

---

### Deflation

- 1) To deflate the Inflatable Vest with LIFT™, reverse the oral inflation tube dust cap and insert it into the valve or depress valve with a fingertip. The dust cap will not lock in the deflate position so it is necessary to hold it in place (Fig. 11).

- 2) Gently squeeze the Vest until all air or gas has been expelled (Fig. 11). Do not ring or twist (see Re-arming Your PFD (p. 13) and Repacking (p. 17) sections of this manual).



### **Usage Below Freezing**

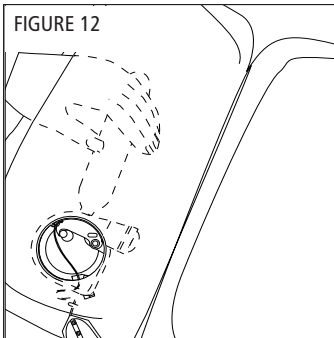
When the temperature is below freezing, a fully discharged cylinder may not adequately inflate your Inflatable Vest with LIFT™. Under these conditions use the oral inflator to top-up the Inflatable Vest with LIFT™.

It may be necessary to manually release the Velcro™ tabs for full inflation because oral inflation may not provide sufficient pressure to open the tabs.

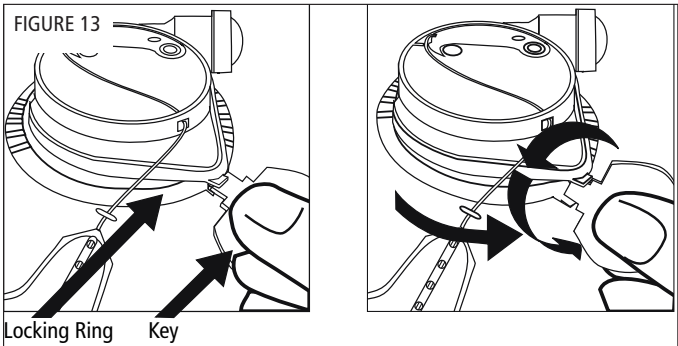
## Re-arming Your PFD

**NOTE: A valid re-arm kit (MA7218) is required for this procedure.**

- 1) Place the Inflatable Vest with LIFT™ on a smooth, flat surface and wipe off any water. Access the inflator by reaching under the cover and pull it toward you, turning the cell and cover inside-out to fully expose the inflator for re-arming. Hold the CO<sub>2</sub> cylinder through the fabric, using one hand (Fig. 12).

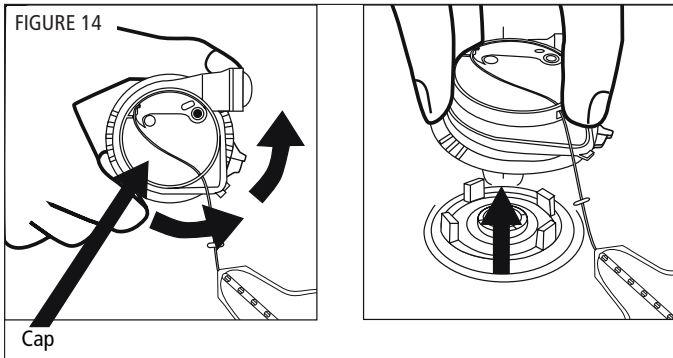


- 2) Insert the metal key between the black locking ring and labeled yellow cap. Turn the key counter-clockwise (Fig. 13).

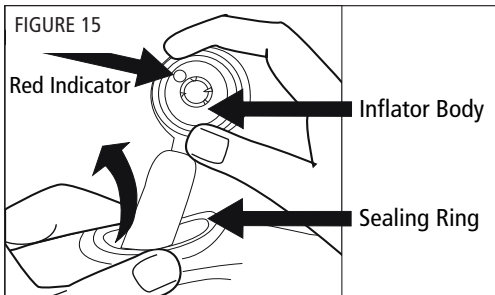




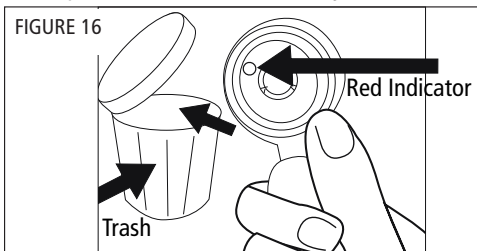
- 3) Turn the black locking ring counter-clockwise and lift off the cap (yellow inflator operating head Fig. 14). Dispose of the used cap.



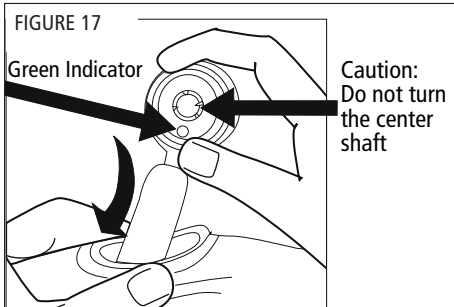
- 4) Squeeze the sealing ring to elongate and remove the inflator body (Fig. 15).



- 5) Dispose of the used inflator body.



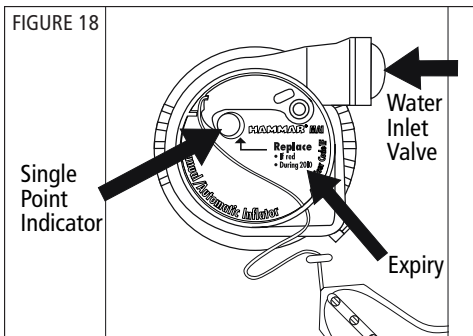
- 6) Check that the new inflator body indicator is green. Insert the new inflator body with CO<sub>2</sub> cylinder pointing upward inside the Inflatable PFD (Fig. 17). Let the sealing ring rest on the adapter around the four lugs.



- 7) Now check the new manual/automatic cap as follows (Fig. 18):

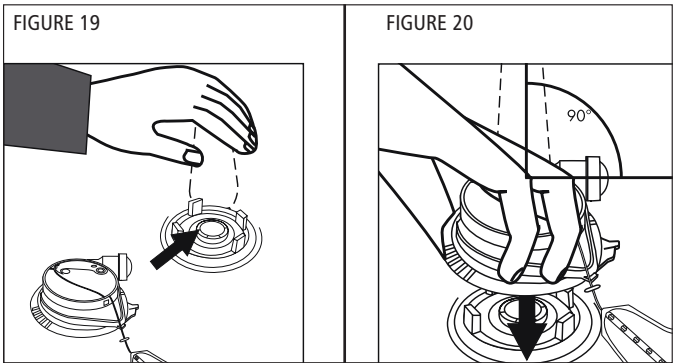
1. Is the single point status indicator showing green?
2. Is the expiry day OK?

If YES is the answer to both questions, then proceed as follows. If the answer is NO to either question, get a new cap.

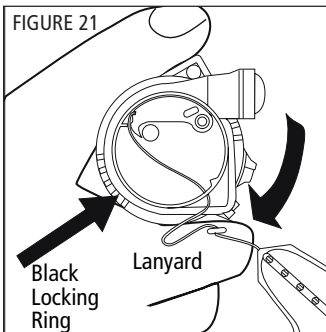


- 8) Hold the CO<sub>2</sub> cylinder through the fabric of the Inflatable Vest with LIFT™ (Fig. 19). Position the replacement cap with the water inlet valve pointing to the right and press firmly onto the inflator body

and sealing ring (Fig. 20).



- 9) While pressing **FIRMLY** onto the inflator body, turn the **BLACK** locking ring clockwise into the locked position (Fig. 21). Pull on the cap to make sure it has locked onto the inflator body.



- 10) **Check:** To see that the single point status indicator on the cap is green; the pull to inflate lanyard is present and that the locking ring is locked.
- 11) Refold the Inflatable Vest with LIFT™ in accordance with the Repacking section (p. 17).

## Repacking

**IMPORTANT: Carefully read the entire Repacking instructions to achieve a properly packed Inflatable Vest with LIFT™**

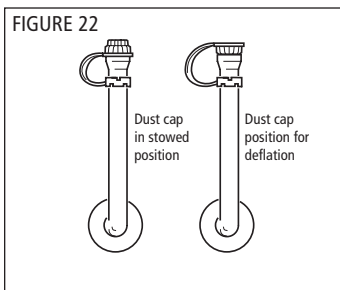
If your Inflatable Vest with LIFT™ has been used and/or the hydrostatic inflator replaced, always inflate through the oral tube and check that it stays inflated at least overnight. With the dust cap in the top of the oral tube, gently squeeze the Inflatable Vest with LIFT™ until **all** air or gas has been expelled (Fig. 11). Do not wring or twist the Inflatable Vest with LIFT™. Put the oral tube dust cap back in its stowed position on the oral tube (Fig. 22). Let the life jacket dry before packing.

1) Before repacking:

- Completely deflate the Inflatable Vest with LIFT™ (see Deflation p. 11).
- Remove the optional harness (MA1900), if equipped.

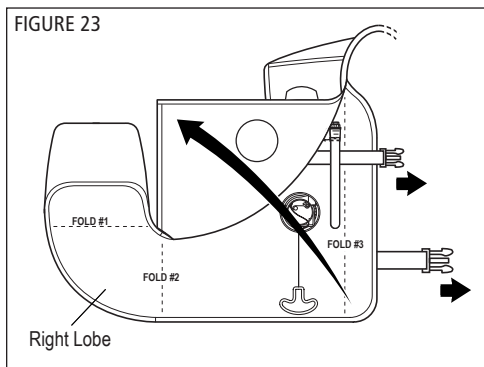
**NOTE: Before following the repacking sequence, be sure to properly re-arm your Inflatable Vest with LIFT™ See Re-arming Your PFD (p.13).**

2) Ensure the oral-inflation dust cap is fitted in the stowed position (Fig. 22).



3) Open **both** front panel covers. Adjust the waist belt and chest belt buckles to their **full lengths** so that the Inflatable Vest with LIFT™ is laid out flat (Fig. 23 shows the right lobe, as worn).

FIGURE 23



- 4) Lay out flat the right lobe (as it is worn). Shift the left lobe (as it is worn) on the waist belt to fully extend the right lobe for folding.

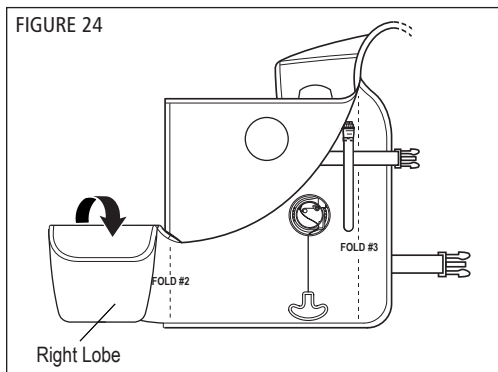
---

**NOTE: The numbered fold lines, on the diagram, are provided to assist with packing. Make each fold towards yourself.**

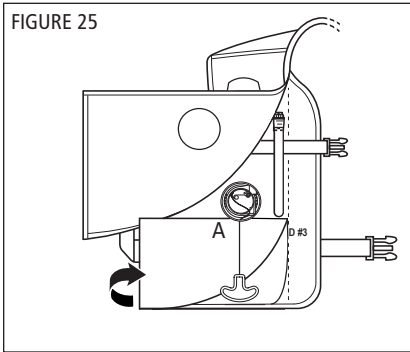
---

- 5) Fold the right lobe (as it is worn) over on the Fold #1 dashed line (Fig. 24). Note that the right lobe has the inflator with cylinder.

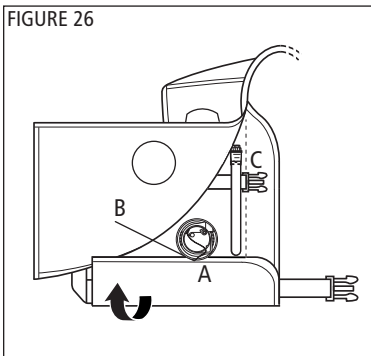
FIGURE 24



- 6) Continuing with the right lobe, fold it over on the Fold #2 dashed line (Fig. 25). Ensure that the bladder is tucked under the inflator to prevent it from blocking the indicator window (Point A).



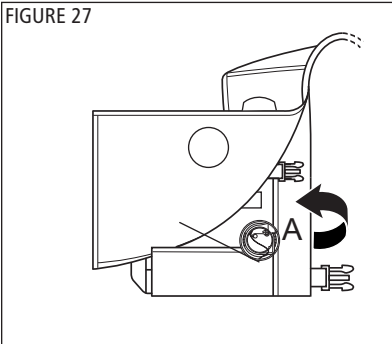
- 7) Fold the bottom portion of the lobe over (Fig. 26).
- Position the lobe so it does not cover the inflator (Point A).
  - Put the inflator pull-tab through the opening in the cover (Point B).
  - Position the chest buckle under the cover (Point C).



8) Fold the lobe over on the Fold #3 dashed line (Fig. 27).

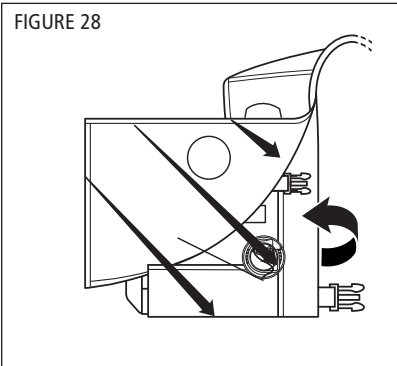
- a. Position the folded lobe so it **does not** cover the inflator (Point A).

FIGURE 27



9) Fold the cover panel down so that it covers the lobe (Fig. 28).

FIGURE 28



10) Mustang Survival uses advanced 2-step zippers - SecureZIP™. Find the left zipper tail and **ZIP 1 - Reset** the 2-step zipper by pulling the slider to the Velcro™ tab (Fig. 29). **ZIP 2 - Close** by pulling slider in the opposite direction to the end the zipper (Fig. 30). Ensure that the Inflatable cell does not get caught by the zipper when closing.

\

FIGURE 29

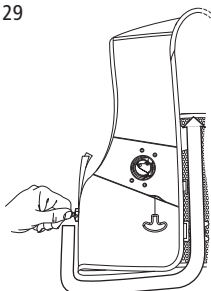
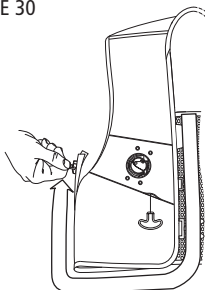


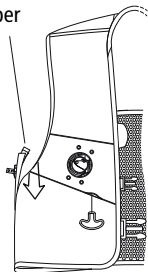
FIGURE 30



11) Tuck in the zipper tail, so it is not exposed (Fig. 31).

FIGURE 31

Zipper  
Tail



12) The right lobe should now be fastened closed and the inflator should be visible through the clear window. The inflator pull-tab should be located just outside the opening in the cover (Fig. 31).

---

**NOTE: Ensure the chest buckle does not extend outside of the lobe, it should sit under the cover.**

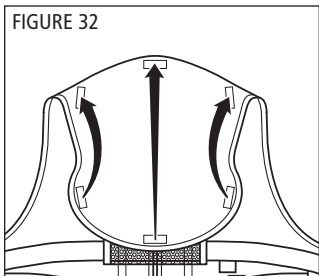
---

13) Repeat steps 3-12 for the left lobe (as it is worn). Note that the left lobe does not have an inflator or indicator window.

14) Turn over the Inflatable Vest with LIFT™ and fold the back flap up and fasten the three (3) Velcro™ tabs (Fig. 32).

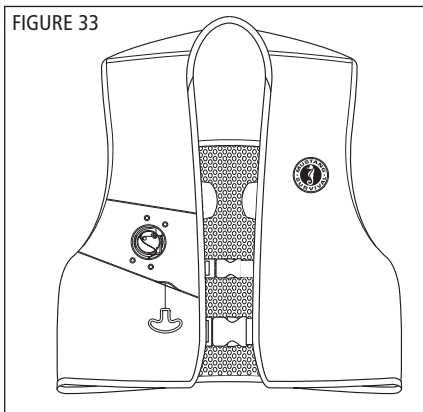


FIGURE 32



- 15) Use the adjustable waist belt to size to fit. When complete, the garment should appear as shown (Fig. 33) and be secure for use or storage.

FIGURE 33



## MA1900 SAILING HARNESS (USE WITH MD0450 ONLY)

The sailing harness is designed to prevent the user from falling overboard when used with a tether with a quick-release under-load release hook and has been designed and tested in accordance with Offshore Racing Council (ORC) requirements. Care and attention must be taken to ensure that the harness is used and maintained correctly.

The harness is to be worn by individuals that are at least 5 feet 5 inches tall. The harness should be worn as high on the chest as possible. However, in all cases, the belt should be worn at least 2 inches above the lowest rib measured from the bottom of the belt and should not be used if it does not fit in this manner. Adjust the harness by donning the harness and using the sliders so that it is as snug as tolerable. Failure to adjust the harness properly could result in injury. The harness may now be inserted into the Inflatable Vest with LIFT™ (MD0450 only, see INSERTING THE MA1900 SAILING HARNESS, p. 22).

When attached to the boat; use a tether of less than 6 feet 6 inches in length with quick-release under-load hardware.

Ensure that a tether, if used, is secured to both harness rings (MD0450 only).

---

**WARNING: Use of a sailing harness to prevent falls overboard presents several risks. In case of capsizing or sinking, the boat may take you down. As such, ensure that any tether used has quick-release under-load hardware. This harness has not been designed for fall arrest, lifting or climbing and should not be relied upon in any of these instances.**

---

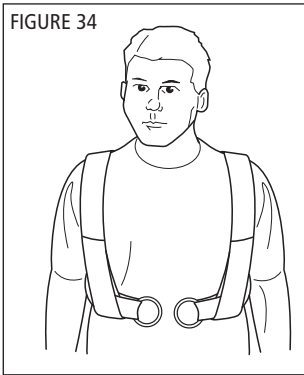
US Coast Guard approval does not apply to this harness and the potential for injury has not been assessed.

## **INSERTING THE MA1900 SAILING HARNESS**

Use this section if you are using a MA1900 Sailing Harness with the Inflatable Vest with LIFT™ (Model MD0450 only).

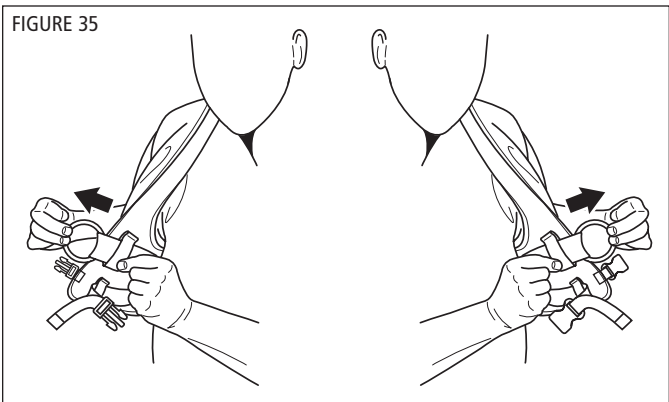
- 1) Put the MA1900 Sailing Harness on as you would a vest, and fasten and adjust the belt to fit (see Adjusting the MA1900 Sailing Harness, p. 27). The label should be facing towards the body (not visible).

FIGURE 34

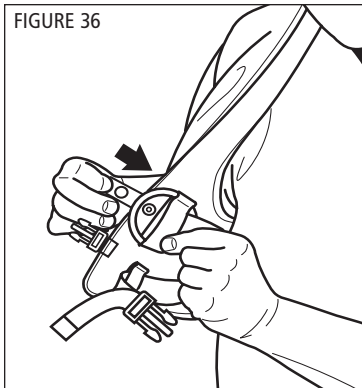


- 2) Put the packed Inflatable Vest with LIFT™ on over the MA1900 Harness. Don't fasten the waist buckle.
- 3) Place the MA1900 Sailing Harness left ring through the Inflatable Vest with LIFT™ left elastic loop and the right ring through the right elastic loop (Fig. 35). Ensure the buckles pass through the elastic loops, with the rings.

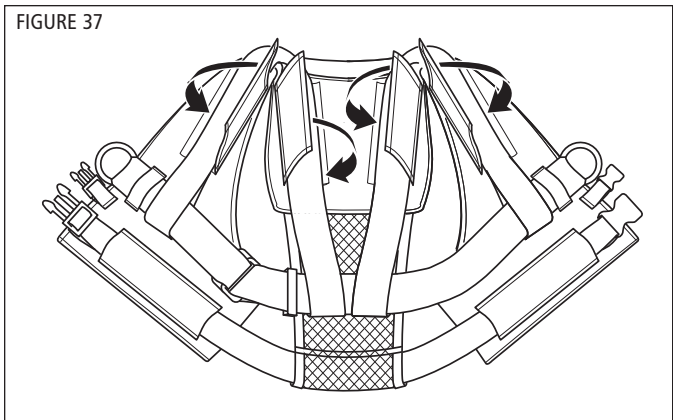
FIGURE 35



- 4) Secure the right sailing harness ring by fastening the right sailing harness ring strap (Fig. 36). Repeat for the left sailing harness ring.

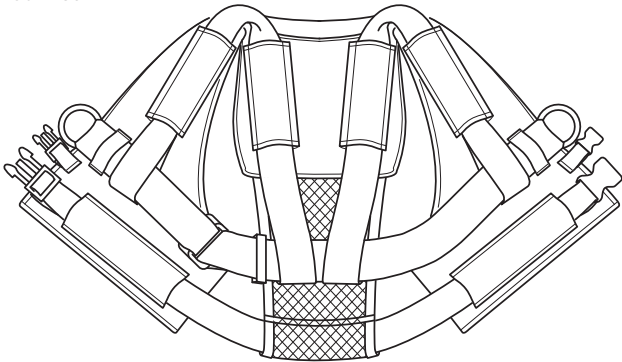


- 5) Lay out the Inflatable Vest with LIFT™ (MD0450) with the inside facing up.
- 6) Open the four harness closures and enclose the harness straps by fastening the Velcro strips (Fig. 37).



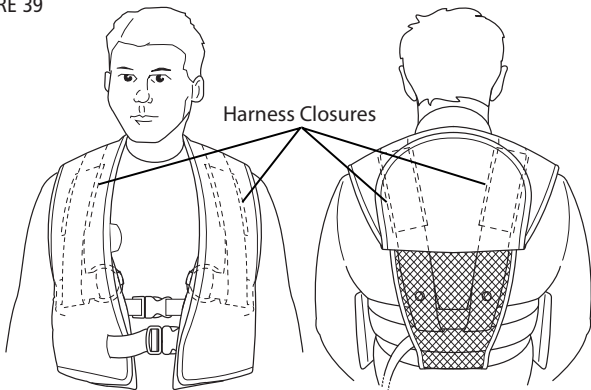
- 7) The Inflatable Vest with LIFT™ (MD0450) with integrated MA1900 Harness should appear as in Fig. 38.

FIGURE 38



- 8) The Inflatable Vest with LIFT™ (MD0450) with integrated MA1900 Harness is shown with dashed lines under the vest (Fig. 39).

FIGURE 39



## ADJUSTING THE MA1900 SAILING HARNESS

Use this section if you are using a MA1900 Sailing Harness with the Inflatable Vest with LIFT™ (Model MD0450 only).

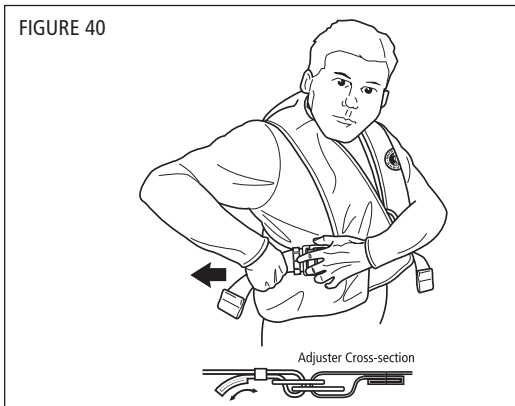
Put the harness on and adjust the harness to a tight personal fit when the harness rings are tethered. Adjust by pulling (to tighten) or letting out (to loosen) the free end of left-side body strap in relation to the strap adjuster (Fig. 40). To test fit, pull the harness rings together. Re-adjust as required.

---

**WARNING: The harness must be adjusted to fit prior to inflation. Once the Inflatable Vest with LIFT™ is inflated, the harness may no longer be adjusted.**

---

Repack the PFD in accordance with the Repacking instructions (p. 17).



### IS YOUR PFD IN GOOD AND SERVICEABLE CONDITION?

Check your PFD between outings to be sure that it is properly armed, as shown by green single point indicator; that it is free of rips, tears or holes; that all seams are securely sewn; and that the fabric, straps and hardware are still strong. Inspect the inflatable portion of the PFD in accordance with the CARE AND MAINTENANCE INSTRUCTIONS (p. 28).

## CARE AND MAINTENANCE INSTRUCTIONS

Federal Regulations require Coast Guard approved personal flotation devices (PFDs) that are legibly marked with the Coast Guard approval number, are in good and serviceable condition, and are the correct size for each person on board. It is the responsibility of the wearer to be sure this PFD is in serviceable condition. To be considered serviceable, this PFD shall not exhibit deterioration that could diminish its performance, such as broken or deformed hardware, detached webbing, rotted structural components, air leaks or nonfunctional inflators. Unless worn inflated, this PFD must also be properly armed with a cylinder installed in the inflator, and single point status indicator showing green. See Page 4 for instructions. Failure to follow these instructions rigorously could result in a non-functioning PFD causing injury or death.

Check the following at the intervals listed below.

### 1) **Before Each Use:**

- i) Examine the single point status indicator through the window panel, ensuring it is green. If the indicator is red, the mechanism requires service. See Re-arming Your PFD, p. 13.
- ii) Ensure the manual pull-tab is accessible.
- iii) Visually examine your Inflatable Vest with LIFT™ for damage or excessive abrasion, wear, tear or contamination. Particular attention must be paid to the stitching, straps and hardware. If in doubt, send it to your Mustang dealer for evaluation and/or servicing.

### 2) **Every Two (2) Months:**

- i) **Leak Test:** The Inflatable Vest with LIFT™ should be tested for general leakage by orally inflating your Inflatable Vest with LIFT™ until firm and let stand 16 hours. A leaking Inflatable Vest with LIFT™ will not hold its firmness and should be replaced. If your Inflatable Vest with LIFT™ leaks, take it to your Mustang dealer for evaluation and/or servicing. Repack the Inflatable Vest with LIFT™ as outlined in the Repacking section (p. 17).

ii) Oral Inflation Valve Test: To check the oral inflation valve, fully inflate the Inflatable Vest with LIFT™ using the oral inflator and hold valve under water. If bubbles appear, deflate and re-inflate to test again. Should the leak persist, take your Inflatable Vest with LIFT™ to your Mustang dealer for evaluation and/or servicing.

---

**CAUTION: To avoid accidental inflation, don't allow the water to contact the hydrostatic inflator.**

---

iii) Perform a thorough visual examination. See **Readiness Checklist** (p. 6).

Perform these tests more often if exposed to potential damage or used in extreme conditions.

3) **After Each Inflation** - Re-arm the Inflatable Vest with LIFT™. See Re-arming Your PFD, p. 13.

4) **Annually** - Perform the following at the beginning of each boating season, after inflation, or whenever the integrity of the Inflatable Vest with LIFT™ is in doubt:

i) Check all components for dirt or corrosion. Clean or replace, as necessary. See **Readiness Checklist** (p. 6).

ii) Visually examine your Inflatable Vest with LIFT™ for damage or excessive abrasion, wear, tear or contamination. Particular attention must be paid to the stitching, straps and hardware. If in doubt, send it to your Mustang dealer for evaluation and/or servicing.

iii) Perform the Leak Test. See the Leak Test (section 2) i) in the Care and Maintenance Instructions).

iv) Perform the Oral Inflation Valve Test: See the Oral Inflation Valve Test (section 2) ii) in the Care and Maintenance Instructions).

v) Ensure the current date is not past the date on the inflator. If it is, replace the inflator (see Re-arming Your PFD, p. 13).

vi) Ensure the single point status indicator is green (Fig. 2).

vii) Record as an "Annual" inspection in permanent ink on the Care and Storage label, in the Date Maintained column.



Repack the Inflatable PFD as outlined in the Repacking section (p. 17).

---

**WARNING: If you are not confident in the self-inspection and servicing of your Inflatable Vest with LIFT™ in accordance with these instructions, take your Inflatable Vest with LIFT™ to a Mustang dealer for professional servicing or contact Mustang Survival (see contact information on back of manual).**

---

## **Cleaning and Storing**

To avoid inflation, do not submerge the Inflatable Vest with LIFT™ or directly spray the inflator. Hand wash or sponge down the Inflatable PFD in warm, soapy water. Rinse the PFD and inflator with clean water, using a clean rinse cloth. Hang the Inflatable Vest with LIFT™ to dry on a plastic coat hanger. Do not dry clean.

Always store your Inflatable Vest with LIFT™ in a warm, dry place out of direct sunlight.

## **HOW AND WHY TO TEST YOUR PFD**

Inflate your Inflatable Vest with LIFT™ and try it out in the water to:

- Make sure it floats you:
  - Comfortably (when worn properly)
  - Adequately for expected wave conditions (body shapes/densities affect performance)
- Make sure it works:
  - A flow of bubbles should not appear (see CARE AND MAINTENANCE INSTRUCTIONS for leak tests p. 28). It should inflate quick and easily.
- Learn how it works by:
  - Activating the CO<sub>2</sub> inflation system
  - Re-arming the CO<sub>2</sub> inflation system
  - Using the oral inflator tube

## HOW DO YOU TEST YOUR PFD USING THE AUTOMATIC INFLATOR?

The U.S.Coast Guard recommends that you purchase at least one spare re-arming kit (MA7218).

- 1) To test your Inflatable Vest with LIFT™, you will need your fully armed Inflatable Vest with LIFT™, and re-arming kit (MA7218) approved for your Inflatable Vest with LIFT™.
- 2) Put on the Inflatable Vest with LIFT™.
- 3) Get into shallow water, just deep enough that you can stand with your head above the surface. Once the inflator is underwater, 4 inches or so, the Inflatable Vest with LIFT™ should fully inflate automatically within 5 seconds.
- 4) See if the Inflatable Vest with LIFT™ will float you on your back or just slightly back of vertical. In a relaxed floating position, verify that your mouth is well above the water's surface. Note the effect of where you hold your legs on how you float.
- 5) Get out of the water and remove the Inflatable Vest with LIFT™.
- 6) Deflate the Inflatable Vest with LIFT™ by depressing the oral inflator valve (see Deflation p. 11). Remove the used inflator.
- 7) Let the Inflatable Vest with LIFT™ dry thoroughly. Re-arm (p. 13) and Repack the PFD (p. 17).

## HOW DO YOU TEST YOUR PFD USING THE MANUAL INFLATOR?

The U.S.Coast Guard recommends that you purchase at least one spare re-arming kit (MA7218).

- 1) To test your Inflatable Vest with LIFT™, you will need your fully armed Inflatable Vest with LIFT™, and re-arming kit approved for your Inflatable Vest with LIFT™: MA7218.

- 2) Put on the Inflatable Vest with LIFT™.
- 3) Actuate the inflation system by jerking firmly downward on the pull-tab. The Inflatable Vest with LIFT™ should fully inflate within 5 seconds.
- 4) Get into shallow water, just deep enough that you can stand with your head above the surface.
- 5) See if the Inflatable Vest with LIFT™ will float you on your back or just slightly back of vertical. In a relaxed floating position, verify that your mouth is well above the water's surface. Note the effect of where you hold your legs and how you float.
- 6) Get out of the water and remove the Inflatable Vest with LIFT™. Completely deflate the Inflatable Vest with LIFT™ using the oral inflator (see Deflation p. 11).
- 7) Let the Inflatable Vest with LIFT™ dry thoroughly. Re-arm (p. 13) and Repack the PFD (p. 17).

## HOW DO YOU TEST YOUR PFD USING THE ORAL INFLATOR?

This test is not mandatory, however may be conducted using the following procedure.

---

**WARNING: Use only a previously fired hydrostatic inflator to perform this test . DO NOT test with a fully armed hydrostatic inflator as double inflation may occur, possibly resulting in cell damage.**

---

- 1) No spare parts or re-arming kits are needed to test your Inflatable PFD.
- 2) Put on the Inflatable Vest with LIFT™.
- 3) Get into shallow water, just deep enough that you can stand with your head above the surface.
- 4) If you are a weak swimmer or non-swimmer, inflate the Inflatable

Vest with LIFT™ partially so that you are supported well enough to be able to complete inflation without touching bottom, either orally or manually. Note this level of inflation because it is the minimum needed for you to safely use this Inflatable Vest with LIFT™.

- 5) Fully inflate the Inflatable Vest with LIFT™ using the oral inflator. It may be necessary to manually release the Velcro™ tabs for full inflation because oral inflation may not provide sufficient pressure to open the tabs.
- 6) See if the Inflatable Vest with LIFT™ will float you on your back or just slightly back of vertical. In a relaxed floating position, verify that your mouth is well above the water's surface. Note the effect of where you hold your legs and how you float
- 7) Get out of the water and remove the Inflatable Vest with LIFT™. Completely deflate the Inflatable Vest with LIFT™ using the oral inflator (see Deflation p. 11).
- 8) Let the Inflatable Vest with LIFT™ dry thoroughly. Re-arm (p. 13) and Repack the PFD (p. 17).

Re-assemble inflation system parts and repack the Inflatable Vest with LIFT™.

## **WEAR YOUR PFD**

In approximately 80 percent of all boating fatalities, the victims were not wearing a PFD. Most fatal accidents happen on calm sunny days. This inflatable PFD is much more comfortable to wear than other PFD types. Get into the habit of wearing this PFD.

Non-swimmers and children especially should wear a hybrid or non-inflatable PFD at all times when on or near the water.

## HYPOTHERMIA

Prolonged exposure to cold water causes a condition known as hypothermia – a substantial loss of body heat, which leads to exhaustion and unconsciousness. Most drowning victims first suffer from hypothermia. The following chart shows the effects of hypothermia: how hypothermia affects most adults.

### How hypothermia affects most adults

Water Temperature °C (°F)	Exhaustion or Unconsciousness	Expected Time of Survival
0.3 (33)	Under 15 min.	Under 15–45 min.
0.3–4 (33–40)	15–30 min.	30–90 min.
4–10 (40–50)	30–60 min.	1–3 hrs
10–16 (50–60)	1–2 hrs.	1–6 hrs.
16–21 (60–70)	2–7 hrs.	2–40 hrs.
21–27 (70–80)	2–12 hrs.	3 hrs. to Indefinite
Over 27 (over 80)	Indefinite	Indefinite

PFDs can increase survival time because they allow you to float without using energy treading water and because of their insulating properties. Naturally, the warmer the water, the less insulation you will require. When operating in cold waters [below 60°F (15.6°C)] you should consider using a coat or jacket style PFD or a Type V Thermal Protective PFD as they cover more of the body than the vest or belt style PFDs. Some Points to Remember About Hypothermia Protection:

- 1) Always wear your PFD. Even if you become incapacitated due to hypothermia, the PFD will keep you afloat and greatly improve your chances of rescue.
- 2) Do not attempt to swim unless it is to reach a nearby craft, fellow survivor, or a floating object on which you can lean or climb. Swimming increases the rate of body heat loss. In cold water, drown-proofing methods that require putting your head in the water are not recommended. Keep your head out of the water. This will greatly

lessen heat loss and increase your survival time.

- 3) Use the standard H.E.L.P. position when wearing an inflatable PFD, drawing the legs up to a seated position, because doing so will help you conserve body heat (Fig. 41).
- 4) Keep a positive attitude about your survival and rescue. This will improve your chances of extending your survival time until rescued. Your will-to-live does make a difference!
- 5) If there is more than one person in the water, huddling is recommended while waiting to be rescued. This action tends to reduce the rate of heat loss and thus increase the survival time.

FIGURE 41



## **EACH OF THESE DEVICES IS INTENDED TO HELP YOU SAVE YOUR OWN LIFE**

For your PFD to function properly, follow these suggestions to verify that it fits, floats, and remains in good condition.

- 1) Check the inflation mechanism status indicator before each use.
- 2) Get in the habit of re-arming the inflation mechanism immediately after each CO<sub>2</sub> inflation (be sure the inflator is dry before re-arming).
- 3) Try your wearable PFD on and adjust it until it fits comfortably in and out of the water.
- 4) Mark your PFD with your name if you are the only wearer.
- 5) Do not alter your PFD. If it doesn't fit properly, get one that does.

An altered device is no longer Coast Guard approved.

- 6) Your PFD is not intended for use as a fender or kneeling pad.
- 7) If your PFD is wet, allow it to dry thoroughly before storing it. Store it in a well-ventilated area.
- 8) Do not dry your PFD in front of a radiator or other source of direct heat.

## **SAFETY ACCESSORIES**

For MD0450 and MD0451, use MA7218 Re-arm Kit, 38-gram CO<sub>2</sub> replacement cylinder and inflator body.

## **ADDITIONAL INFORMATION**

If you need more information about PFDs and safe boating, contact your state boating authority, U.S. Coast Guard Auxiliary, U.S. Power Squadron, Red Cross, or your nearest unit of the U.S. Coast Guard. To find out about free boating courses in your area call 1-800-336-BOAT (in Virginia, call 800-245-BOAT).

## **DO NOT ATTACH PFD'S TO YOUR BOAT**

Each PFD has straps, hooks, buckles, or other means for securing the device in place on the wearer. Some PFDs also incorporate decorative D-rings or tabs. Such items are not to be used to attach the device to the boat. Attaching the device to the boat will not permit it to perform as intended.

---

**NOTE: The MA1900 Harness is intended for attaching to a boat with a quick-release under-load tether secured to both harness rings. Do not attach the MA1900 Harness to the boat using any other means.**

---

## **AIRLINE OPERATOR POLICY ON CARRIAGE OF INFLATABLE PFDS AND CO<sub>2</sub> CARTRIDGES**

Please be aware that the following regulations apply to the air transport of this product. According to U.S. Department of Transportation (DOT), PHMSA - the Pipeline and Hazardous Materials Safety Administration Title 49 CFR 75.10(a)(25): With the approval of the aircraft operator, one small carbon dioxide cylinder (not installed), plus one spare cartridge, may be carried by a passenger or crew as checked baggage.

Please refer to the governing body's documentation, found online at <http://www.phmsa.dot.gov/>







**WE SAVE LIVES FOR A LIVING**

[www.mustangsurvival.com](http://www.mustangsurvival.com)

TOLL FREE 1.800.526.0532  
EMAIL [custserv@mustangsurvival.com](mailto:custserv@mustangsurvival.com)

Mustang Survival and seahorse design are registered trademarks of Mustang Survival Corp.

Our commitment to quality has earned our Burnaby facilities ISO 9001 registration, the highest of all international standards. This is our guarantee you're receiving the ultimate in design and manufacturing.

**HT1124** (Rev 10Aug2011)

## Free Manuals Download Website

<http://myh66.com>

<http://usermanuals.us>

<http://www.somanuals.com>

<http://www.4manuals.cc>

<http://www.manual-lib.com>

<http://www.404manual.com>

<http://www.luxmanual.com>

<http://aubethermostatmanual.com>

Golf course search by state

<http://golfingnear.com>

Email search by domain

<http://emailbydomain.com>

Auto manuals search

<http://auto.somanuals.com>

TV manuals search

<http://tv.somanuals.com>