



C720BEE

Stereo Receiver



Owner's Manual
Manuel d'Installation
Bedienungsanleitung
Gebruikershandleiding
Manual del Usuario
Manuale delle Istruzioni
Manual do Proprietário
Bruksanvisning

ENGLISH

FRANÇAIS

DEUTSCH

NEDERLANDS

ESPAÑOL

ITALIANO

PORTUGUÊS

SVENSKA



IMPORTANT SAFETY INSTRUCTIONS

- Save these instructions for later use.
- Follow all warnings and instructions marked on the audio equipment.

- 1 Read instructions** - All the safety and operating instructions should be read before the product is operated.
- 2 Retain instructions** - The safety and operating instructions should be retained for future reference.
- 3 Heed Warnings** - All warnings on the product and in the operating instructions should be adhered to.
- 4 Follow Instructions** - All operating and use instructions should be followed.
- 5 Cleaning** - Unplug this product from the wall outlet before cleaning. Do not use liquid cleaners or aerosol cleaners. Use a damp cloth for cleaning.
- 6 Attachments** - Do not use attachments not recommended by the product manufacturer as they may cause hazards.
- 7 Water and Moisture** - Do not use this product near water-for example, near a bath tub, wash bowl, kitchen sink, or laundry tub; in a wet basement; or near a swimming pool; and the like.
- 8 Accessories** - Do not place this product on an unstable cart, stand, tripod, bracket, or table. The product may fall, causing serious injury to a child or adult, and serious damage to the product. Use only with a cart, stand, tripod, bracket, or table recommended by the manufacturer, or sold with the product. Any mounting of the product should follow the manufacturer's instructions, and should use a mounting accessory recommended by the manufacturer.
- 9 A product and cart combination** should be moved with care. Quick stops, excessive force, and uneven surfaces may cause the product and cart combination to overturn.
- 10 Ventilation** - Slots and openings in the cabinet are provided for ventilation and to ensure reliable operation of the product and to protect it from overheating, and these openings must not be blocked or covered. The openings should never be blocked by placing the product on a bed, sofa, rug, or other similar surface. This product should not be placed in a built-in installation such as a bookcase or rack unless proper ventilation is provided or the manufacturer's instructions have been adhered to.

11 Power Sources - This product should be operated only from the type of power source indicated on the marking label. If you are not sure of the type of power supply to your home, consult your product dealer or local power company.

The primary method of isolating the turntable from the mains supply is to disconnect the mains plug. Ensure that the mains plug remains accessible at all times. Unplug the AC power cord from the AC outlet if the unit will not be used for several months or more.

12 Grounding or Polarization - This product may be equipped with a polarized alternating-current line plug (a plug having one blade wider than the other). This plug will fit into the power outlet only one way. This is a safety feature. If you are unable to insert the plug fully into the outlet, try reversing the plug. If the plug should still fail to fit, contact your electrician to replace your obsolete outlet. Do not defeat the safety purpose of the polarized plug.

13 Power-Cord Protection - Power-supply cords should be routed so that they are not likely to be walked on or pinched by items placed upon or against them, paying particular attention to cords at plugs, convenience receptacles, and the point where they exit from the product.

14 Outdoor Antenna Grounding - If an outside antenna or cable system is connected to the product, be sure the antenna or cable system is grounded so as to provide some protection against voltage surges and built-up static charges. Article 810 of the National Electrical Code, ANSI/NFPA 70, provides information with regard to proper grounding of the mast and supporting structure, grounding of the lead-in wire to an antenna discharge unit, size of grounding conductors, location of antenna discharge unit, connection to grounding electrodes, and requirements for the grounding electrode.

NOTE TO CATV SYSTEM INSTALLER

- *This reminder is provided to call the CATV system installer's attention to Section 820-40 of the NEC which provides guidelines for proper grounding and, in particular, specifies that the cable ground shall be connected to the grounding system of the building, as close to the point of cable entry as practical.*

15 Lightning - For added protection for this product during a lightning storm, or when it is left unattended and unused for long periods of time, unplug it from the wall outlet and disconnect the antenna or cable system. This will prevent damage to the product due to lightning and power-line surges.

16 Power Lines - An outside antenna system should not be located in the vicinity of overhead power lines or other electric light or power circuits, or where it can fall into such power lines or circuits. When installing an outside antenna system, extreme care should be taken to keep from touching such power lines or circuits as contact with them might be fatal.

17 Overloading - Do not overload wall outlets, extension cords, or integral convenience receptacles as this can result in a risk of fire or electric shock.

18 Object and Liquid Entry - Never push objects of any kind into this product through openings as they may touch dangerous voltage points or short-out parts that could result in a fire or electric shock. Never spill liquid of any kind on the product.

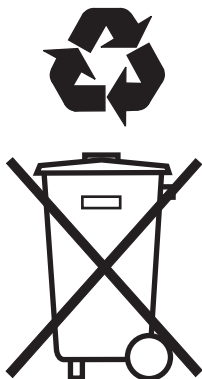

19 Damage Requiring Service - Unplug this product from the wall outlet and refer servicing to qualified service personnel under the following conditions:

- a) When the power-supply cord or plug is damaged.
- b) If liquid has been spilled, or objects have fallen into the product.
- c) If the product has been exposed to rain or water.
- d) If the product does not operate normally by following the operating instructions. Adjust only those controls that are covered by the operating instructions as an improper adjustment of other controls may result in damage and will often require extensive work by a qualified technician to restore the product to its normal operation.
- e) If the product has been dropped or damaged in any way.
- f) when the product exhibits a distinct change in performance-this indicates a need for service.

20 Replacement Parts - When replacement parts are required, be sure the service technician has used replacement parts specified by the manufacturer or have the same characteristics as the original part. Unauthorized substitutions may result in fire, electric shock, or other hazards.

21 Safety Check - Upon completion of any service or repairs to this product, ask the service technician to perform safety checks to determine that the product is in proper operating condition.

22 Wall or Ceiling Mounting - The product should be mounted to a wall or ceiling only as recommended by the manufacturer.

WARNING



TO PREVENT FIRE OR SHOCK HAZARD, DO NOT EXPOSE THIS APPLIANCE TO RAIN OR MOISTURE. THE LIGHTNING FLASH WITH ARROWHEAD SYMBOL, WITHIN AN EQUILATERAL TRIANGLE, IS INTENDED TO ALERT THE USER TO THE PRESENCE OF UNINSULATED "DANGEROUS VOLTAGE" WITHIN THE PRODUCT'S ENCLOSURE THAT MAY BE OF SUFFICIENT MAGNITUDE TO CONSTITUTE A RISK OF ELECTRIC SHOCK TO PERSONS.



THE EXCLAMATION POINT WITHIN AN EQUILATERAL TRIANGLE IS INTENDED TO ALERT THE USER TO THE PRESENCE OF IMPORTANT OPERATING AND MAINTENANCE (SERVICING) INSTRUCTIONS IN THE LITERATURE ACCOMPANYING THE APPLIANCE

CAUTION

Changes or modifications to this equipment not expressly approved by NAD Electronics for compliance could void the user's authority to operate this equipment.

CAUTION REGARDING PLACEMENT

To maintain proper ventilation, be sure to leave a space around the unit (from the largest outer dimensions including projections) equal to, or greater than, shown below.

Left and Right Panels : 10 cm

Rear Panel : 10 cm

Top Panel : 50 cm

IMPORTANT INFORMATION FOR UK CUSTOMERS

DO NOT cut off the mains plug from this equipment. If the plug fitted is not suitable for the power points in your home or the cable is too short to reach a power point, then obtain an appropriate safety approved extension lead or consult your dealer. If, nonetheless, the mains plug is cut off, REMOVE THE FUSE and dispose of the PLUG immediately, to avoid possible shock hazard by inadvertent connection to the mains supply. If this product is not provided with a mains plug, or one has to be fitted, then follow the instructions given below:

IMPORTANT

DO NOT make any connection to the larger terminal which is marked with the letter 'E' or by the safety earth symbol or coloured GREEN or GREEN AND YELLOW.

The wires in the mains lead on this product are coloured in accordance with the following code:

BLUE - NEUTRAL

BROWN - LIVE

As these colours may not correspond with the coloured markings identifying the terminals in your plug, proceed as follows:

The BLUE wire must be connected to the terminal marked with the letter 'N' or coloured BLACK.

The BROWN wire must be connected to the terminal marked with the letter 'L' or coloured RED

When replacing the fuse, only a correctly rated and approved type should be used, and be sure to re-fit the fuse cover.

IF IN DOUBT CONSULT A COMPETENT ELECTRICIAN

This product is manufactured to comply with the radio interference requirements of EEC DIRECTIVE 89/68/EEC and 73/23/EEC



Model No. : _____ Serial No. : _____

ABOUT THE C 720BEE

REAR PANEL CONTROLS

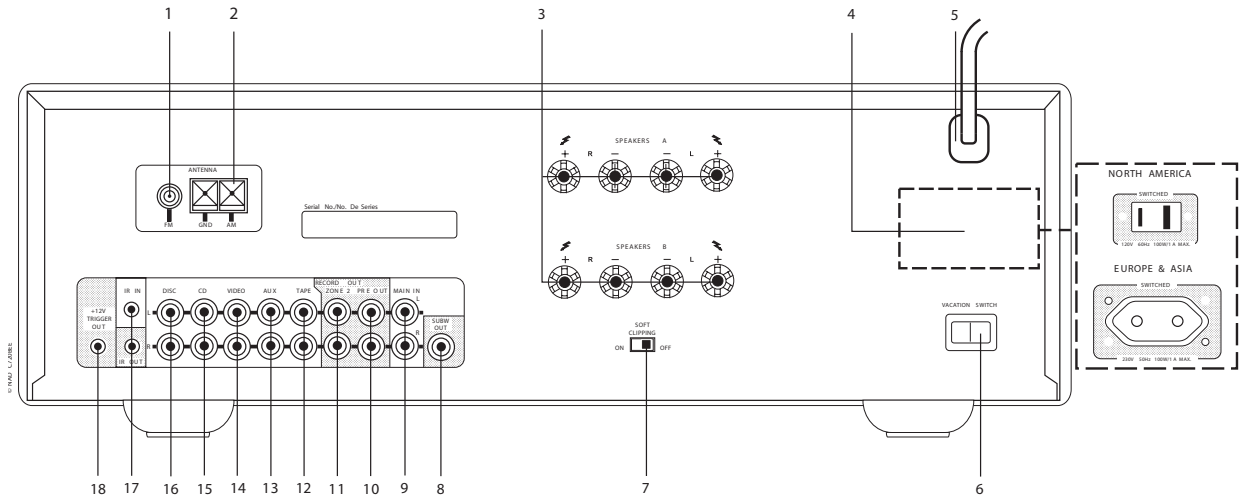

FRONT PANEL CONTROLS

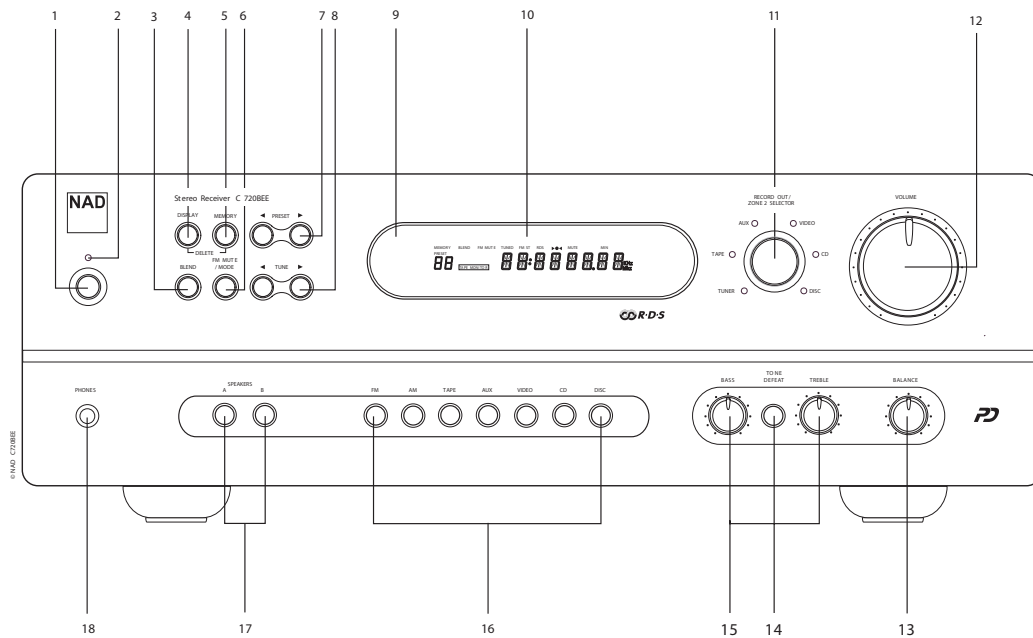

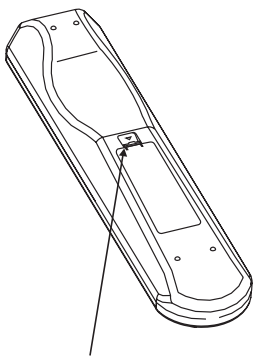
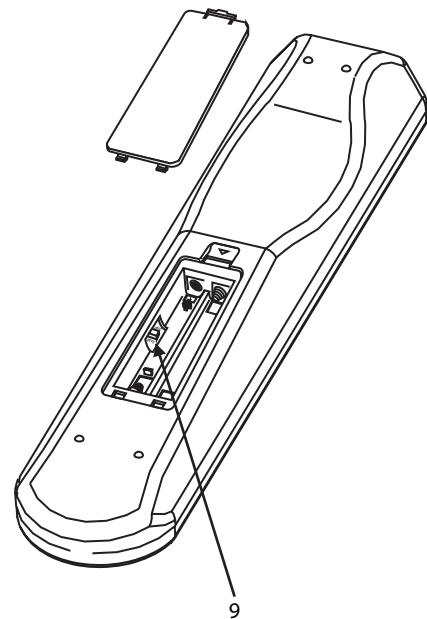
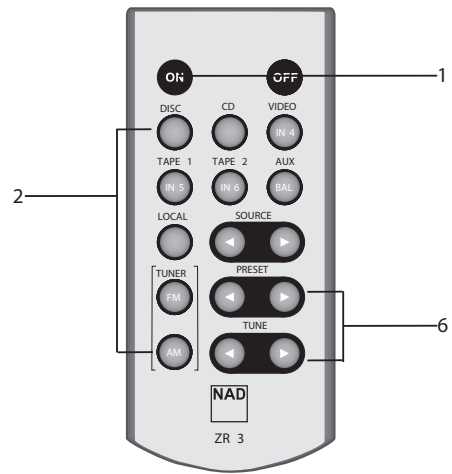
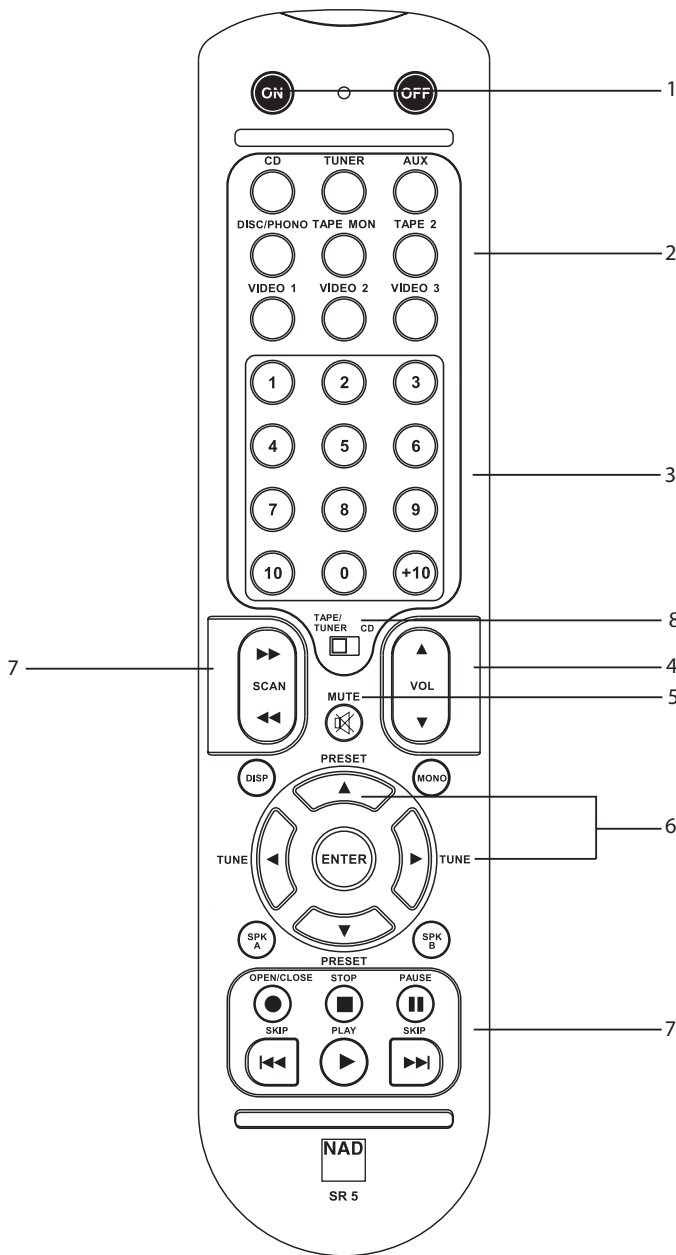

PRESS IN AND LIFT TAB TO REMOVE BATTERY COVER OUT FROM RECESS

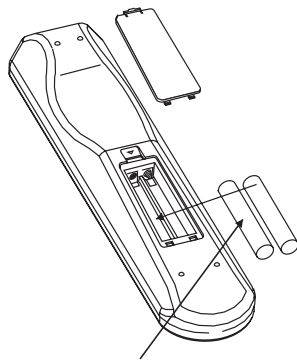

PLACE BATTERIES INTO OPENING. ENSURE THE CORRECT POLARITY IS OBSERVED

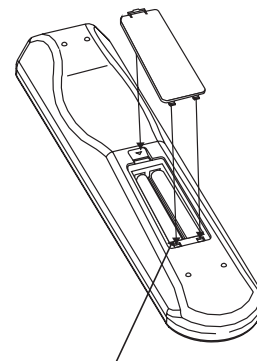

REPLACE BATTERY COVER BY ALIGNING AND INSERTING THE TWO TABS INTO THE HOLES.

PRESS BATTERY COVER INTO PLACE UNTIL IT 'CLICKS' CLOSED

NOTES ON INSTALLATION

Your NAD C720BEE should be placed on a firm, level surface. Avoid placing the unit in direct sunlight or near sources of heat and damp. Allow adequate ventilation. Do not place the unit on a soft surface like a carpet. Do not place it in an enclosed position such a bookcase or cabinet that may impede the air-flow through the ventilation slots. Make sure the unit is switched off before making any connections.

The RCA sockets on your NAD C720BEE are colour coded for convenience. Red and white are Right and Left audio respectively. Use high quality leads and sockets for optimum performance and reliability. Ensure that leads and sockets are not damaged in any way and all sockets are firmly pushed home.

For best performance, use quality speaker leads of 16 gauge (1.5mm) thickness or more. If the unit is not going to be used for some time, disconnect the plug from the AC socket.

Should water get into your NAD C720BEE, shut off the power to the unit and remove the plug from the AC socket. Have the unit inspected by a qualified service technician before attempting to use it again.

DO NOT REMOVE THE COVER, THERE ARE NO USERSERVICEABLE PARTS INSIDE.

Use a dry soft cloth to clean the unit. If necessary, lightly dampen the cloth with soapy water. Do not use solutions containing benzol or other volatile agents.

QUICK START

- 1 Connect the speakers to the rear Speaker terminals and sources to the relevant rear input sockets.
- 2 Plug in the AC power cord.
- 3 Press the VACATION button on the back of the C720BEE.
- 4 Press the POWER button to turn the NAD C720BEE on.
- 5 Press the required input selector.

REAR PANEL CONNECTIONS

ATTENTION!

Please make all connections to your C720BEE receiver with the unit powered off or unplugged. (It is also advisable to power-down or unplug all associated components while making or breaking any signal or AC power connections.)

1-2 FM & AM ANTENNA: The supplied wire "dipole" FM antenna will connect to the FM connector using the supplied "balun" adapter. It will usually work best when mounted on a vertical surface such as a wall, with arms fully outstretched forming a horizontal "T" perpendicular to the origin point of the signal. Experiment with placement and orientation of to yield the clearest sound and lowest background noise. In areas of difficult FM reception an external FM antenna can yield dramatic gains in quality; consult your NAD audio specialist or a professional antenna installer.

The AM loop antenna supplied with the C720BEE (or a suitable replacement) is required for AM reception. Open the clip terminal levers insert the wire and close, ensuring that the lever locks the wire in place. Testing different positions for the antenna may improve reception; vertical orientation will usually produce the best results. Antenna proximity to large metal objects (appliances; radiators) may impair reception, as will attempts to lengthen the wire to the loop.

NOTE:

An external AM antenna can improve long-distance reception substantially; consult your NAD audio specialist or a professional antenna installer. Do not connect anything other than a loop antenna to the AM ANTENNA terminal. Do not remove the AM loop antenna.

3 SPEAKERS A & B - Speaker terminals for speakers with an impedance of 4 ohms or more. Connect the right speaker to the terminals marked 'R +' and 'R-' ensuring that the 'R+' is connected to the '+' terminal on your loudspeaker and the 'R-' is connected to the loudspeaker's '-' terminal. Connect the terminals marked 'L+' and 'L-' to the left speaker in the same way. Always use heavy duty (16 gauge; 1.5mm, or thicker) stranded wire to connect loudspeakers to your NAD C720BEE. The high-current binding post terminals can be used as a screw terminal for cables terminating in spade or pin sockets or for cables with bare wire ends.

BARE WIRES AND PIN CONNECTORS

Bare wires and pin sockets should be inserted into the hole in the shaft of the terminal. Unscrew the speaker terminal's plastic bushing until the hole in the screw shaft is revealed. Insert the pin or bare cable end into the hole and secure the cable by tightening down the terminal's bushing. Ensure bare wire from the speaker cables does not touch the back panel or another socket. Ensure that there is only 1/2" (1cm) of bare cable or pin and no loose strands of speakers wire.

POWERDRIVE

To meet the diverse requirements of high current drive and high dynamic power, our patented PowerDrive amplifier circuit will build further on our reputation for amazingly effective power. By adding a second high-voltage rail to our well regulated high-current power supply, we get an "overdrive" that can nearly double the continuous power on a short term dynamic power basis. This is a further development and refinement of our renowned Power Envelope circuit, utilized by NAD in the 80's and 90's. PowerDrive differs from Power Envelope in that it offers greater amplifier stability and low impedance drive capability, resulting in less distortion when driving real speakers with real program material.

4 SWITCHED AC OUTLET - The AC power cord of another component may be plugged into this accessory outlet. Components plugged into this outlet will be switched On and Off by the VACATION SWITCH on the rear panel.

NOTE:

The total power consumption of any components connected to the AC outlets may not exceed 100 Watts.

5 AC line cord - Plug the AC power cord into a live AC wall socket. Make sure all connections have been made before connecting to mains.

6. VACATION SWITCH ON/OFF The VACATION switch is the master on/off control for the amplifier. When the switch is in the ON state the amplifier is in standby as shown by the amber LED above the power switch on the front panel. If the amplifier will not be used for an extended period of time, switch the VACATION switch to the OFF position.

7 SOFT CLIPPING™ - When an amplifier is driven beyond its specified power output, a hard, distorted sound can be heard on very loud sounds. This is caused by the amplifier cutting off or 'hard clipping' the peaks of sound that was not designed to reproduce. The NAD Soft Clipping circuit gently limits the output of the system to minimize audible distortion if the amplifier is overdriven. If your listening involves moderate power levels you may leave the Soft Clipping switch to Off. If you are likely to play at high levels, that could stretch the amplifier's power capability, then switch Soft Clipping On

8 SUBW OUT Connect the SUBW OUT output to a powered ("active") subwoofer (or to power amplifier channel driving a passive system). The subwoofer output roll-off frequency is 100 Hz at -3dB.

9 MAIN IN - Use these connections to an external pre-amplifier or processor, such as a surround-sound decoder. In normal use these

should be connected to the Pre-Out sockets with the links supplied. To connect your NAD C720BEE to external processor or pre-amplifier first remove these links. Use a twin RCA-to-RCA lead to connect to the left and right 'Audio Output' of the pre-amp or processor to the Main-In sockets.

NOTE:

Always turn the amplifier off before connecting or disconnecting anything from to Pre-Out and Main-In sockets.

10 PRE-OUT - Connections to an external power amplifier or processor, such as a surround-sound decoder. In normal use these should be connected to the Main-In sockets (No. 10) with the links supplied. To connect your NAD C720BEE to external processor or amplifier sections first remove these links. Use a twin RCA-to-RCA lead to connect to the left and right 'Audio Input' of the Power amp or processor to the Pre Out sockets.

NOTE

The Pre-Out output signal will be affected by the NAD C720BEE's volume and tone control settings, always turn the amplifier off before connecting or disconnecting anything from to Pre-Out and Main-In sockets.

11 RECORD OUT/ZONE 2 - Connect the left and right 'Audio Input' of the tape machine to the TAPE OUT sockets for recording. For use as a zone 2 source, connect the left and right "Audio Input" of an integrated amplifier line in sockets to these line level outputs.

12 TAPE IN - Connections for analogue playback of an audio tape recorder of any type. Using twin RCA-to-RCA leads, connect to the left and right 'Audio Output' of the tape machine to the TAPE 1 IN sockets for playback.

13 AUX input - Input for additional line level input signals such as another CD player. Use a twin RCA-to-RCA lead to connect the auxiliary unit's left and right 'Audio Outputs' to this input.

14 VIDEO input - Input for the audio signal from a stereo VCR (or stereo TV/Satellite/Cable receiver) or other line-level audio source. Using twin RCA-to-RCA leads, connect to the left and right 'Audio Outputs' of the unit to these inputs. NOTE: These are audio inputs only.

15 CD input - Input for a CD or other line-level signal source. Use a twin RCA-to-RCA lead to connect the CD player's left and right 'Audio Outputs' to this input. The NAD C720BEE only accepts analogue signals from your CD player.

16 DISC input - Input for additional line level input signals such as CD, Mini Disc player or the output signal from a step-up amplifier (such as the NAD PP2) for a turntable. Use a twin RCA-to-RCA lead to connect the auxiliary unit's left and right 'Audio Outputs' to this input.

17 IR Input / Output - This input is connected to the output of an IR (infrared) repeater (Xantech or similar), or the IR output of another component to allow control of the C720BEE from a remote location. Ask your dealer or custom installer for further details.

18 +12V TRIGGER OUT - The 12V TRIGGER OUTPUT is used for controlling external equipment that is equipped with a 12V trigger input. This output will be 12V when the C720BEE is on and 0V when the unit is either off or in standby. This output can drive a load up to 50mA at 12V.

The plug required is a standard 3.5mm Mini-Jack plug ("mono"): The tip is the live or + connection, the shaft of the input jack is the 12V-trigger - or ground connection.

NOTES:

Check the specifications of the Trigger input terminal on the other components to ensure these are compatible with the C 720BEE's 12Vtrigger output. NAD components equipped with 12V input triggers are fully compatible with the C720BEE's 12V output trigger. Before making any connections to any 12V trigger input or output, make sure all components are disconnected from the AC mains. Failure to observe the above may result in damage to the C720BEE or any ancillary components attached to it. If in doubt over the connections, installation and operation of the 12V trigger output consult your NAD dealer.

FRONT PANEL CONTROLS

1 Power - Press the POWER button to switch the unit from Stand-by to the operating mode; The Stand-by indicator (Fig. 2; No. 2) will turn from amber, to red, then to green. Press the POWER button to switch the unit to the Stand-by mode: The Stand-by indicator will light up amber. Upon selecting any input at the front panel or the ON button of the remote, the C720BEE will choose the last selected as the active input.

NOTE:

The remote control handset supplied with the C720BEE is of a universal NAD type, designed to operate several NAD models. Some buttons on this handset are inoperative, as the functions aren't supported by the C720BEE.

2 Power/Standby/Protection LED - Upon switching the power on, the LED will light up red for a few seconds before the protection circuit is deactivated. In cases of serious abuse of the amplifier, such as overheating, excessively low loudspeaker impedance, short circuit etc. the amplifier will engage its Protection circuitry, indicated by the LED turning from green to red, and the sound being muted. In such a case, turn the amplifier off, wait for it to cool down and/or check the speaker connections, making sure the overall loudspeaker impedance doesn't go below 4 ohms. Once the cause for the protection circuitry to engage has been removed, press Power again to resume normal operation.

3 BLEND The Blend button toggles between engaging or disengaging the Blend feature; when engaged, "BLEND" lights up in the VFD.

4 DISPLAY When the AM/FM tuner is the selected input, sequentially pressing DISPLAY shows the currently tuned station's RDS data, toggling between the current station's Radio Text and Station Name displays

5 MEMORY Use to store tuned stations to the C720BEE's 40 preset-memory locations.

6 FM MUTE/MODE - In the normal Mute position, only the stations with a strong signal can be listened to, and the noise between stations is muted. Pressing the [FM Mute/Mode] button allows distant (and potentially noisy) stations to be received.

7 PRESET - Press either PRESET buttons to step up or down between radio presets; 30 FM and 10 AM station presets are available. NOTE that this function "wraps": Pressing the PRESET buttons will step from Preset 30 to Preset 1, or vice versa. "Unused" presets are skipped over. (NOTE that Presets must previously have been stored)

8 TUNE - Press either TUNE button momentarily to step up or down between FM or AM frequencies. Press and hold TUNE buttons for more than 2 seconds to search up or down; the C720BEE's tuner will stop at the next sufficiently strong signal it encounters. NOTE that this function, too, "wraps," and will continue searching up or down from one end of the AM or FM band to the other.

NOTE that: TUNE button increments the FM band by 0.05 MHz steps (twice the precision of most tuners). On the AM band, TUNE increments the AM band by 10 kHz or 9 kHz steps. To change the step amount, select AM and then hold in the FM MUTE/MODE and AM keys simultaneously.

9 Infra-red remote control command receiver - The infrared sensor, located beside the VFD, receives commands from the remote control. There must be a clear line-of-sight path from the remote control to this window; if that path is obstructed, the remote control may not work.

NOTE:

Direct sunlight or very bright ambient lighting may affect the operating range and angle for the remote control handset.

10 DISPLAY PANEL - The Display Panel shows information about the C720BEE's operating modes and information about the station currently selected, Audio Mute, Blend, FM Mute, Stereo, Centre Tune, etc. are all indicated in this window. The display also has an eight character alphanumeric section, which will display the active input, station name, Radio Text or frequency.

11 RECORD OUT/ZONE 2 SELECTOR - This selector switch doubles as both a record source selector and a second zone source. Control is also achieved by use of the ZR-3 zone remote control.

12 VOLUME - The VOLUME control adjusts the overall loudness of the signals being fed to the loudspeakers. It is motor driven and can be adjusted from the remote control handset. The VOLUME control does not affect recordings made using the Tape outputs but will affect the signal going to the Pre-amp output (Pre Out).

On the remote control handset, press the MUTE button to temporarily switch off the sound to the speakers and headphones.

Mute mode is indicated by the MUTE icon in the VFD. Press the MUTE button again to restore sound. Mute does not affect recordings made using the Tape output but will affect the signal going to the Pre-amp output (Pre Out).

13 BALANCE - The BALANCE control adjusts the relative levels of the left and right speakers. The 12 o'clock position provides equal level to the left and right channels. A detent indicates this position. Rotating the control clockwise moves the balance towards the right. Rotating the control anti-clockwise moves the balance to the left. The BALANCE control does not affect recordings made using the Tape output but will affect the signal going to the Pre-amp output (Pre Out).

14 TONE DEFEAT - The TONE DEFEAT switch by-passes the tone control section of the NAD C720BEE. If the Tone Controls are not normally used and left in the 12 o'clock position, then it is advisable to switch out the Tone Control section altogether by using this switch. In the 'out' position, the Tone Control circuits are active; pushing the TONE DEFEAT switch 'in' bypasses the Tone Control section.

15 Tone controls - The NAD C720BEE is fitted with BASS and TREBLE tone controls to adjust the tonal balance of your system. The 12 o'clock position is 'flat' with no boost or cut, and an indent indicates this position. Rotate the control clockwise to increase the amount of Bass or Treble. Rotate the control anti-clockwise to decrease the amount of Bass or Treble. The Tone controls do not affect recordings made using the Tape outputs but will affect the signal going to the Pre-amp output (Pre Out).

16 Input selectors - These buttons select the active input to the C720BEE and the signal sent to the loudspeakers, the Tape output and the PRE OUT sockets. The buttons on the remote control handset duplicate these buttons, with the exception of the Video 1 input.

DISC Selects a line-level source connected to the DISC sockets as the active input.

CD Selects the CD (or other line-level source) connected to the CD sockets as the active input.

VIDEO Selects the VCR (or stereo TV/Satellite/Cable receiver) connected to the VIDEO sockets as the active input.

AUX Selects a line-level source connected to the AUX sockets as the active input.

FM Selects the FM tuner.

AM Selects the AM tuner.

NOTE:

The SR-5 remote control handset has one TUNER button; toggle for selecting between AM and FM.

NOTE:

The ZR-3 remote control has separate buttons for AM and FM; pressing either one will select the C720BEE's tuner input.

TAPE Selects the output from a tape recorder when playing back tapes or monitoring recordings made through the Tape socket.

NOTE:

When TAPE is selected, TAPE MONITOR will light up in the VFD

NOTE:

The RECORD OUT / ZONE 2 SELECTOR will not allow access to TAPE when TAPE is selected.

17 SPEAKER A & B - The Speakers A and B buttons engage or disengage the speakers connected respectively to the Speakers A and Speakers B terminals on the rear panel. Press A to switch the speakers connected to the speaker A terminals On or Off. Press B to switch the speakers connected to the speaker B terminals On or Off. The indicator directly over the buttons shows the status of both speakers A and B.

If Speakers A and B are both engaged (both indicators over the Speakers A and B buttons are lit), the amplifier's output power is fed to both sets of speakers in parallel. If speakers A and B are disengaged, both sets of speakers are silenced. You can use this setting mode to listen to headphones.

18 PHONES Socket - A 1/4" stereo jack socket is supplied for headphone listening and will work with conventional headphones of any impedance. The volume, tone and balance controls are operative for headphone listening. Use a suitable adapter to connect headphones with other types of sockets, such as 3.5mm stereo 'personal stereo' jack plugs.

NOTE:

Make certain that the volume control is turned to minimum (fully anti-clockwise) before connecting or disconnecting headphones. Listening at high levels can damage your hearing.

REMOTE CONTROL HANDSET

The Remote Control handset handles all the key functions of the NAD C720BEE and has additional controls to remotely operate NAD Cassette and CD machines. It will operate up to a distance of 16ft (5m). Alkaline batteries are recommended for maximum operating life. Two AAA (R 03) batteries should be fitted in the battery compartment at the back of the Remote Control handset. When replacing batteries, check that they have been put in the right way round, as indicated on the base of the battery compartment.

Please refer to previous sections of the manual for a full description of individual functions.

When a command from the remote control is received, the Standby/protection indicator will blink.

1 POWER ON & OFF - The NAD C720BEE remote has a separate On and Off button. This can be particularly useful to keep components within a system "insync": This way all components will switch to stand-by when Off is pressed or switch to operating mode when On is pressed, instead of some components switching On when the amplifier is switched to Stand-by. (Note that the other components have to be capable of responding to the separate On and Off commands as well). Press the ON button to switch the unit from Stand-by to the operating mode; The Stand-by indicator (Fig. 2; No. 2) will turn from amber, to red, then to green. Press the OFF button to switch the unit to the Stand-by mode: The Stand-by indicator will light up amber.

2 INPUTS - The input selector buttons perform the same functions as the buttons labelled the same on the front panel.

3 Numeric Keys - The numeric keys allow for direct input of tracks for CD-players, and direct channel/preset access for the tuner.

4 MASTER VOLUME - Press the MASTER VOLUME ▲ or ▼ buttons to respectively increase or decrease the loudness level. Release the button when the desired level is reached. The motorised Volume Control on the front panel will indicate the level set. The Master Volume buttons do not affect recordings made using the Tape outputs but will affect the signal going to the Pre-amp outputs.

5 MUTE - Press the MUTE Button to temporarily switch off the sound to the speakers and headphones. Mute mode is indicated by the MUTE icon in the VFD. Press MUTE again to restore sound. Mute does not affect recordings made using the Tape output but will affect the signal going to the Preamp outputs.

6 TUNER CONTROL - TUNE ◀ or ▶ scans respectively higher or lower station frequencies for both AM and FM.

PRESET ▲ or ▼ selects respectively higher or lower number station preset.

7 CD PLAYER CONTROL - (for use with NAD CD-Player)

- ⏸ engages Pause
- engages Stop
- ▶ engages Play or toggles between Play and Pause or engages Track skip; Press once to respectively go to the next track or to return to start of current or previous track.
- ◀◀◀◀ engages reverse Scan and Skip
- ▶▶▶▶ engages forward Scan and Skip.
- engages CD drawer Open/Close; Press once to open the CD drawer then once again to close the CD drawer and start playback.

7 CASSETTE DECK CONTROL - (for use with single NAD Cassette Decks)

- ▶ engages Forward Play.
- Press to put cassette deck into record-pause, then press Play to start recording.
- Stops Play or Recording.
- ◀◀◀◀ engages Rewind.
- ▶▶▶▶ engages Fast Forward.

8 TAPE/TUNER-CD - The TAPE/TUNER - CD switch applies tape controls to the transport keys when in the TAPE/TUNER position, and applies CD controls to the transport keys when in the CD position.

9 DEV 1/DEV 2 - In some instances when one's audio system is without a tape deck, the CD transport keys may be set to operate in either position of the Tape/Tuner -CD switch (No.8).

The default setting for this remote control switch set to DEV 1. In this position, the Tape/Tuner -CD switch allows for both tape and CD control (No.7). If one sets this switch to DEV 2, then the transport keys will remain as CD control keys irregardless of the position of the Tap/Tuner -CD switch.

NOTES: The remote control handset supplied with the C720BEE is of a universal NAD type, designed to operate several NAD models. Some buttons on this handset are inoperative as the functions aren't supported by the C720BEE. The Video 2 and Video 3 input selector buttons (inside section No.2) on the remote control handset are inoperative in the case of the C720BEE.

Direct sunlight or very bright ambient lighting may affect the operating range and angle for the remote control handset.

LISTENING TO RADIO

The C720BEE's internal AM/FM tuner offers very high quality sound from radio broadcasts. Note that reception and sound quality will always be dependent to a degree on the type of antenna(s) used, as well as proximity to the broadcast origin, geography, and weather conditions.

ABOUT ANTENNAS

The supplied ribbon-wire FM antenna can be connected to the rear-panel FM-antenna input using the 'balun' adapter included, and should be fully extended to form a "T". This folded-dipole antenna will usually work best oriented vertically, with the arms of its "T" full outstretched and arranged perpendicular to the origin of the desired broadcast. There are no 'rules,' however, and experimenting freely with antenna placement and orientation may yield the clearest sound and lowest background noise. In areas of poor FM reception, an exterior FM antenna can improve performance dramatically. If radio listening is important to you, consider consulting an antenna installation professional to optimize your system.

The supplied AM 'loop' antenna will usually provide adequate reception. However, an exterior AM antenna can be used to improve reception; consult an antenna professional for more information.

SELECTING THE RADIO

Press the AM or FM key on the C720BEE front panel, the SR-5's [TUNER] key to select the receiver's radio mode. Each subsequent press of [TUNER] key will toggle the unit between its FM and AM bands.

TUNING STATIONS

Press TUNE on the front panel momentarily to step up or down between FM or AM frequencies. Press and hold TUNE for more than 2 seconds to search up or down; the C720BEE's tuner will stop at the next sufficiently strong signal it encounters. Pressing the either TUNE key momentarily during the search process will stop the search. From the SR-5 press [TUNE]; hold in to automatically search, press momentarily to perform slow manual search.

SR-5 DIRECT FREQUENCY ENTRY

With the SR-5 you can now directly enter the frequency of the radio station. When entering digits, more than two will force the direct entry mode. Pressing ENTER will lock the frequency as seen on the C720BEE's VFD. For example; pressing 1021 will force the direct entry to 102.1.

SETTING RADIO PRESETS

The C720BEE can store as many as 40 of your favorite radio stations for immediate recall; 30 FM stations and 10 AM. To store a radio preset, first tune the desired frequency (see above), then press the front panel MEMORY key. Press either PRESET key to select the preset number to be assigned. Then press the MEMORY key once again.

NOTE: The Radio Presets must be stored from the front panel; this setup function is not accessible from the SR-5 remote.

SELECTING RADIO PRESETS

Press either PRESET key on the front panel to step up or down between presets; press and hold either PRESET key to "scroll" continuously up or down. The SR-5 remote's [PRESET] keys work similarly.

CHOOSING THE FM MUTE / MODE

The front-panel FM MUTE/Mode key is a dual-purpose control. First, it "toggles" the C720BEE between stereo mute and unmuted stereo reception (assuming that a multiplex-stereo station of sufficient strength is tuned). FM Mute eliminates noise from "empty" FM frequencies but also mutes very weak or distant stations; it also causes the search function to skip them. Toggling off the FM Mute will result in reduced noise if the FM station signal level is less than the FM Stereo threshold (since mono FM is inherently less noise-prone), though at the sacrifice of the stereo effect.

NOTE: The one can store the same channel in two preset locations; one with FM Mute On, and with FM Mute Off.

NOTE: Toggling between FM Mute on or off also defeats the C720BEE's FM muting circuit. If you wish to listen to a particularly weak or distant broadcast, toggle off the FM Mute and tune it manually.

CHOOSING THE BLEND MODE

Weak or remote stereo radio stations are sometimes received with noise and hiss as the antenna signal is too weak. Switching the tuner to mono will reduce the amount of noise and hiss but at the expense of any stereo information. The NAD Blend feature will allow you to reduce the amount noise and hiss but still retain some level of stereo separation, instead of mono.

The Blend button toggles between engaging or disengaging the Blend feature; when engaged, "BLEND" lights up in the VFD.

NOTE: The one can store the same channel in two preset locations; one with FM Blend On, and with FM Blend Off.

ABOUT RDS

The Radio Data System (RDS) permits compatible FM receivers to display text determined by the broadcaster. The C720BEE supports two RDS modes, station-name (PS mode) and radio-text (RT mode). However, not every FM station incorporates RDS in its broadcast signal; in most areas you will find from one to several RDS enabled stations, but it is by no means impossible that your favorite stations will not be broadcasting RDS data.

VIEW RDS TEXT

When an RDS-enabled FM broadcast is tuned, after a brief delay the "RDS" symbol will light in the C720BEE's front-panel readout and the readout's character section will show its station-name (PS) text: "ROCK101," for example. Press the front-panel DISPLAY key to toggle the readout between this and the station's radio text (RT) readout, if any, which might scroll song- or artist-name, or any other text of the station's choosing.

ABOUT USER NAMES

You can assign an eight character "User Name" to each radio preset, which will show in the front-panel readout whenever that preset is recalled.

ENTERING USER NAMES

For example, to name a radio preset "NEWS": recall the desired radio preset, and then press the front-panel MEMORY key once, then within five (5) seconds, press the front-panel DISPLAY key; the readout shows a blinking box. Use the TUNE keys to select the first character of the name ("N" from the alphabetic list; press either PRESET key to select the character and move to the next position. Repeat this process for each character in sequence; press the MEMORY key again to store the User Name and exit the text-entry mode.

PRE-AMP SECTION

LINE LEVEL INPUTS(DISC, CD, VIDEO, AUX, TUNER, TAPE)

Input impedance (R and C)	22k Ω + 100pF
Input sensitivity (1V out)	330mV
Maximum input signal	6V
Signal / noise ratio pre-amp out, A-weighted	106dB ref. 500mV
Frequency response 20Hz - 20kHz	< \pm 0.1dB (Tone defeat on) < \pm 0.5dB (Tone defeat off)
THD + Noise, SMPTE IM	< 0.01% at 5V out

LINE LEVEL OUTPUTS

Output impedance Pre-out	80 Ω
Tape Source	Z + 200 Ω
Maximum output level Pre-out	>11V
Tape	>11.5V

TONE CONTROLS

Treble	\pm 5dB at 10kHz
Bass	\pm 8dB at 100Hz

IR / TRIGGER OUT

Input resistance	>100 Ω
Input voltage Minimum	5V
Output resistance	<10 Ω
Output current	50mA
Output voltage	12V

POWER AMP SECTION

Continuous output power into 8 Ω ²	2x50W (17dBW)
Rated distortion (THD 20Hz - 20kHz)	0.03%
Clipping power	
(maximum continuous power per channel 4 Ω and 8 Ω)	65W
IHF Dynamic headroom 8 Ω	+3.4dB
4 Ω	+5.0dB
IHF dynamic power	
(maximum short term power per channel) 8 Ω	110W (20.4dBW)
4 Ω	160W (22.0dBW)
2 Ω ²	220W (23.2dBW)
Damping factor (ref. 8 Ω , 1kHz)	>110
Input impedance (R & C)	20k Ω + 470pF
Input sensitivity (rated output into 8 Ω)	630mV
Voltage gain	29dB
Frequency response 20Hz - 20kHz	+/- 0.2 dB
Signal/noise ratio, A-weighted ref. 1W	100dB
ref. 50W	117dB
Signal / Noise ratio A-weighted ¹	95.0dB ref. 1W
THD + Noise ³	<0.03%
SMPTE IM ⁴	<0.02%
IHF IM ⁵	<0.01%
Headphone output impedance	100 Ω

TUNER SECTION

Input sensitivity	Mono: 16.1dBf
50dB	Stereo: 36.1dBf
Harmonic Distortion;	FM Mono: 0.3%
Harmonic Distortion;	FM Stereo 0.5%
Signal / noise;	Mono 60dB
Signal / noise;	Stereo 55dB
Stereo separation at 1kHz;	40dB
Frequency Response;	± 1.5dB 30Hz - 15kHz

PHYSICAL SPECIFICATIONS

Dimensions (W x H x D)	435 x 147 x 387mm
Net weight	8.7kg (19.2lb)
Shipping weight	11.4kg (25.1lb)

¹ From CD input to speakers output, volume setting for 500mV in, 8Ω 1W out

² Minimum power per channel, 20Hz - 20kHz, both channels driven with no more than rated distortion.

³ Total harmonic distortion, 20Hz - 20kHz from 250mW to rated output

⁴ Intermodulation distortion, 60Hz - 7kHz, 4:1, from 250mW to rated output

⁵ CCIF IM distortion, 19 + 20kHz 250mV to rated output

TROUBLESHOOTING

PROBLEM	CAUSE	SOLUTION
NO SOUND	<ul style="list-style-type: none"> Power AC lead unplugged or power not switched on Tape Monitor selected Mute on 	<ul style="list-style-type: none"> Check if AC lead is plugged in and power switched on De-select Tape Monitor mode Switch off Mute
NO SOUND ON ONE CHANNEL	<ul style="list-style-type: none"> Speaker not properly connected or damaged. Input lead disconnected or damaged 	<ul style="list-style-type: none"> Check connections and speakers Check leads and connections
WEAK BASS/ DIFFUSE STEREO IMAGE	<ul style="list-style-type: none"> Speakers wired out of phase 	<ul style="list-style-type: none"> Check connections to all speakers in the system
REMOTE CONTROL HANDSET NOT WORKING	<ul style="list-style-type: none"> Batteries flat, or incorrectly inserted IR transmitter or receiver windows obstructed IR receiver in direct sun or very bright ambient light 	<ul style="list-style-type: none"> Check or replace batteries Remove obstruction Place unit away from direct sun, reduce amount of ambient light
NO SOUND WITH TUNER	<ul style="list-style-type: none"> Antenna leads incorrectly connected Station not selected or weak signal with FM Mute on. 	<ul style="list-style-type: none"> Check antenna connections to receiver Re-tune or switch off FM Mute
NOISE, HISS ON AM AND FM	<ul style="list-style-type: none"> Weak signal 	<ul style="list-style-type: none"> Check station tuning. Adjust or replace antenna.
DISTORTION ON FM	<ul style="list-style-type: none"> Multi-path signals or interference from another station 	<ul style="list-style-type: none"> Check station tuning. Adjust or replace antenna
WHISTLES OR BUZZES ON FM & AM	<ul style="list-style-type: none"> Interference from other electrical sources - computers, games consoles 	<ul style="list-style-type: none"> Check station tuning. Switch off or move the source of the electrical noise
WHISTLES OR BUZZES ON AM	<ul style="list-style-type: none"> Interference from fluorescent lighting or electrical motors 	<ul style="list-style-type: none"> Check station tuning. Adjust or replace AM antenna
NO RDS NAME (PS)	<ul style="list-style-type: none"> Station signal too weak. Station not transmitting RDS data 	<ul style="list-style-type: none"> Check station tuning. Adjust or replace antenna No remedy



www.NADelectronics.com

**©2005 NAD ELECTRONICS INTERNATIONAL
A DIVISION OF LENBROOK INDUSTRIES LIMITED**

All rights reserved. No part of this publication may be reproduced, stored or transmitted in any form without the written permission of NAD Electronics International

C 720BEE Manual 0105 Printed in China

Free Manuals Download Website

<http://myh66.com>

<http://usermanuals.us>

<http://www.somanuals.com>

<http://www.4manuals.cc>

<http://www.manual-lib.com>

<http://www.404manual.com>

<http://www.luxmanual.com>

<http://aubethermostatmanual.com>

Golf course search by state

<http://golfingnear.com>

Email search by domain

<http://emailbydomain.com>

Auto manuals search

<http://auto.somanuals.com>

TV manuals search

<http://tv.somanuals.com>