

User's Manual

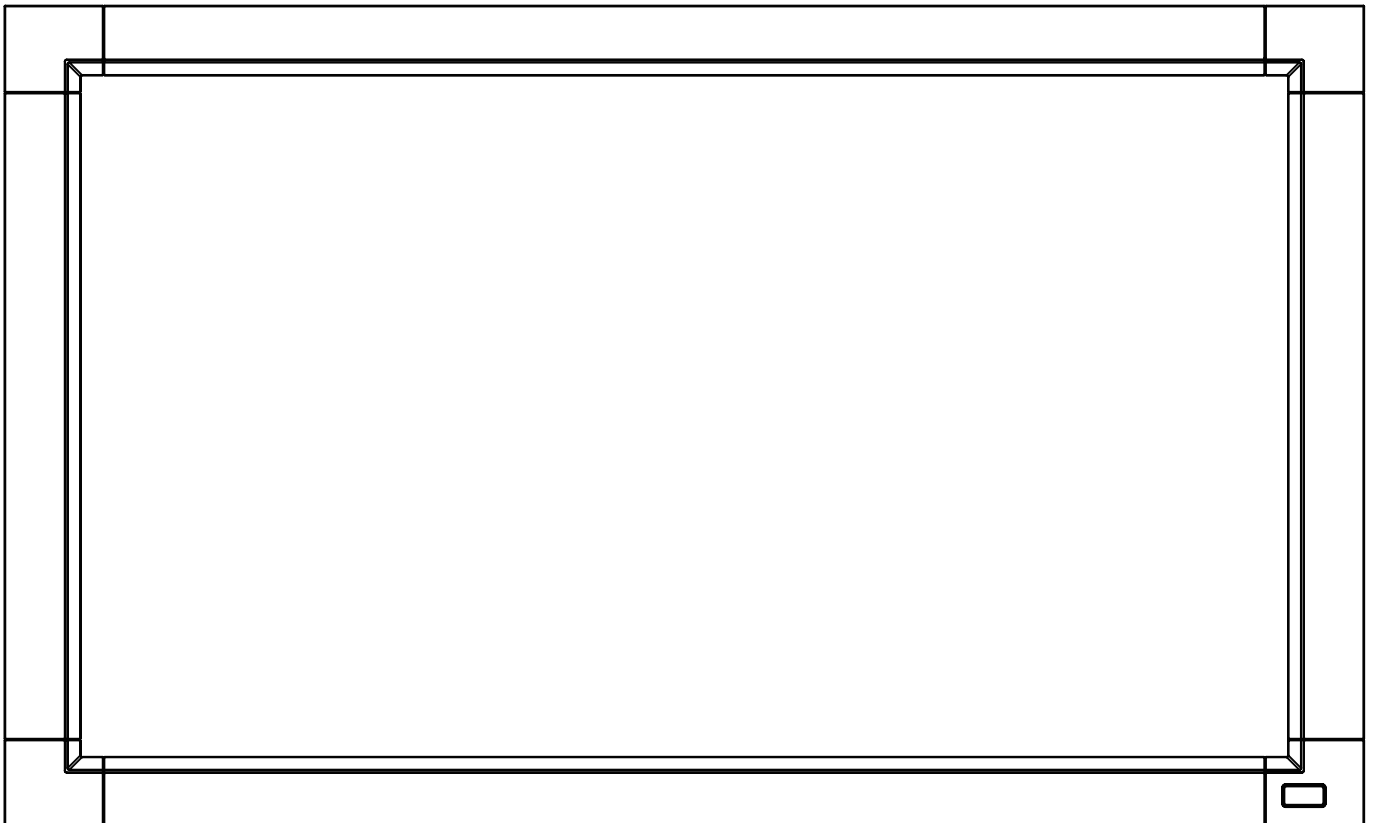

MultiSync LCD3215

MultiSync LCD4215

Index

Important Information	English-1
Warning, Caution	English-1
Registration Information	English-1
Safety Precautions, Maintenance & Recommended Use	English-3
Contents	English-4
Installation	English-5
Parts Name and Functions	English-7
Control Panel	English-7
Terminal Panel	English-8
Wireless Remote Control	English-9
Operating Range for the Remote Control	English-10
Handling the remote control	English-10
Setup	English-11
Connections	English-13
Wiring Diagram	English-13
Connecting a Personal Computer	English-14
Connect the LCD Monitor to a Personal Computer	English-14
Connecting with Digital Interface Equipment	English-15
Connect the LCD Monitor to a Computer with a Digital Output	English-15
Connecting a DVD Player with component out	English-16
Connect the LCD Monitor to a DVD Player	English-16
Connecting to a Stereo Amplifier	English-17
Connect the LCD Monitor to a Stereo Amplifier	English-17
Basic Operation	English-18
Power ON and OFF Modes	English-18
Power Indicator	English-19
Using Power Management	English-19
Selecting a video source	English-19
Picture Size	English-19
Picture Mode	English-19
Information OSD	English-19
OSD (On-Screen-Display) Controls	English-20
PICTURE	English-21
ADJUST	English-21
AUDIO	English-22
SCHEDULE	English-22
PIP	English-22
OSD	English-22
MULTI DISPLAY	English-23
DISPLAY PROTECTION	English-23
ADVANCED OPTION	English-23
Controlling the LCD monitor via RS-232C Remote Control	English-26
Features	English-27
Troubleshooting	English-28
Specifications - LCD3215	English-29
Specifications - LCD4215	English-30
Pin Assignment	English-31
Manufacturer's Recycling and Energy Information	English-32

Important Information



WARNING



TO PREVENT FIRE OR SHOCK HAZARDS, DO NOT EXPOSE THIS UNIT TO RAIN OR MOISTURE. ALSO, DO NOT USE THIS UNIT'S POLARIZED PLUG WITH AN EXTENSION CORD RECEPTACLE OR OTHER OUTLETS UNLESS THE PRONGS CAN BE FULLY INSERTED.

REFRAIN FROM OPENING THE CABINET AS THERE ARE HIGH VOLTAGE COMPONENTS INSIDE. REFER SERVICING TO QUALIFIED SERVICE PERSONNEL.



CAUTION



CAUTION: TO REDUCE THE RISK OF ELECTRIC SHOCK, MAKE SURE POWER CORD IS UNPLUGGED FROM WALL SOCKET. TO FULLY DISENGAGE THE POWER TO THE UNIT, PLEASE DISCONNECT THE POWER CORD FROM THE AC OUTLET. DO NOT REMOVE COVER (OR BACK). NO USER SERVICEABLE PARTS INSIDE. REFER SERVICING TO QUALIFIED SERVICE PERSONNEL.



This symbol warns user that uninsulated voltage within the unit may have sufficient magnitude to cause electric shock. Therefore, it is dangerous to make any kind of contact with any part inside this unit.



This symbol alerts the user that important literature concerning the operation and maintenance of this unit has been included. Therefore, it should be read carefully in order to avoid any problems.

CAUTION: Please use the power cord provided with this display in accordance with the table below. If a power cord is not supplied with this equipment, please contact your supplier. For all other cases, please use a power cord that matches the AC voltage of the power outlet and has been approved by and complies with the safety standard of your particular country.

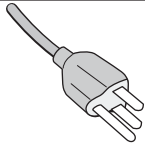
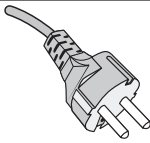
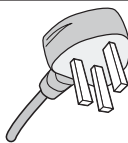
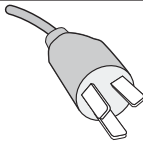
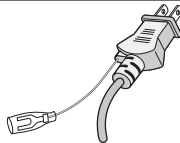
Plug Type	North America	European Continental	U.K.	Chinese	Japanese
Plug Shape					
Region	U.S.A./Canada	EU (except U.K.)	U.K.	China	Japan
Voltage	120*	230	230	220	100

*When operating the MultiSync LCD3215/MultiSync LCD4215 monitor with its AC 125-240V power supply, use a power supply cord that matches the power supply voltage of the AC power outlet being used.

NOTE: This product can only be serviced in the country where it was purchased.

Registration Information

Declaration

Declaration of the Manufacturer

We hereby certify that the color monitor MultiSync LCD3215 (L327HP)/MultiSync LCD4215 (L427HQ) are in compliance with

Council Directive 2006/95/EC:
– EN 60950-1

Council Directive 2004/108/EC:
– EN 55022
– EN 61000-3-2
– EN 61000-3-3
– EN 55024

and marked with



NEC Display Solutions, Ltd.
4-13-23, Shibaura,
Minato-Ku
Tokyo 108-0023, Japan

Canadian Department of Communications Compliance Statement

DOC: This Class B digital apparatus meets all requirements of the Canadian Interference-Causing Equipment Regulations.

C-UL: Bears the C-UL Mark and is in compliance with Canadian Safety Regulations according to CAN/CSA C22.2 No. 60950-1.

FCC Information

1. Use the attached specified cables with the MultiSync LCD3215 (L327HP)/MultiSync LCD4215 (L427HQ) color monitor so as not to interfere with radio and television reception.
 - (1) Please use the supplied power cord or equivalent to ensure FCC compliance.
 - (2) Please use the supplied shielded video signal cable, Mini D-SUB 15 pin to Mini D-SUB 15 pin.
2. This equipment has been tested and found to comply with the limits for a Class B digital device, pursuant to part 15 of the FCC Rules. These limits are designed to provide reasonable protection against harmful interference in a residential installation. This equipment generates, uses, and can radiate radio frequency energy, and, if not installed and used in accordance with the instructions, may cause harmful interference to radio communications. However, there is no guarantee that interference will not occur in a particular installation. If this equipment does cause harmful interference to radio or television reception, which can be determined by turning the equipment off and on, the user is encouraged to try to correct the interference by one or more of the following measures:
 - Reorient or relocate the receiving antenna.
 - Increase the separation between the equipment and receiver.
 - Connect the equipment into an outlet on a circuit different from that to which the receiver is connected.
 - Consult your dealer or an experienced radio/TV technician for help.

If necessary, the user should contact the dealer or an experienced radio/television technician for additional suggestions. The user may find the following booklet, prepared by the Federal Communications Commission, helpful: "How to Identify and Resolve Radio-TV Interference Problems." This booklet is available from the U.S. Government Printing Office, Washington, D.C., 20402, Stock No. 004-000-00345-4.

Declaration of Conformity

This device complies with Part 15 of FCC Rules. Operation is subject to the following two conditions. (1) This device may not cause harmful interference, and (2) this device must accept any interference received, including interference that may cause undesired operation.

U.S. Responsible Party:	NEC Display Solutions of America, Inc.
Address:	500 Park Boulevard, Suite 1100 Itasca, Illinois 60143
Tel. No.:	(630) 467-3000

Type of Product:	Computer Monitor
Equipment Classification:	Class B Peripheral
Model:	MultiSync LCD3215 (L327HP) MultiSync LCD4215 (L427HQ)



We hereby declare that the equipment specified above conforms to the technical standards as specified in the FCC Rules.

Windows is a registered trademark of Microsoft Corporation. NEC is a registered trademark of NEC Corporation. All other brands and product names are trademarks or registered trademarks of their respective owners.

Safety Precautions, Maintenance & Recommended Use

FOR OPTIMUM PERFORMANCE, PLEASE NOTE THE FOLLOWING WHEN SETTING UP AND USING THE MULTI-FUNCTION MONITOR:

- **DO NOT OPEN THE MONITOR.** There are no user serviceable parts inside and opening or removing covers may expose you to dangerous shock hazards or other risks. Refer all servicing to qualified service personnel.
- Do not spill any liquids into the cabinet or use your monitor near water.
- Do not insert objects of any kind into the cabinet slots, as they may touch dangerous voltage points, which can be harmful or fatal or may cause electric shock, fire or equipment failure.
- Do not place any heavy objects on the power cord. Damage to the cord may cause shock or fire.
- Do not place this product on a sloping or unstable cart, stand or table, as the monitor may fall, causing serious damage to the monitor.
- The power supply cord you use must have been approved by and comply with the safety standards of your country. (Type H05VV-F 3G 1mm² should be used in Europe)
- In UK, use a BS-approved power cord with molded plug having a black (13A) fuse installed for use with this monitor.
- Do not place any objects onto the monitor and do not use the monitor outdoors.
- The lamps in this product contain mercury. Please dispose according to state, local or federal law.
- Do not bend, crimp or otherwise damage the power cord.
- If glass is broken, handle with care.
- Do not cover vent on monitor.
- Do not use monitor in high temperature, humid, dusty, or oily areas.
- If monitor or glass is broken, do not come in contact with the liquid crystal and handle with care.
- Allow adequate ventilation around the monitor, so that heat can properly dissipate. Do not block ventilated openings or place the monitor near a radiator or other heat sources. Do not put anything on top of the monitor.
- The power cable connector is the primary means of detaching the system from the power supply. The monitor should be installed close to a power outlet, which is easily accessible.
- Handle with care when transporting. Save packaging for transporting.
- Please clean the holes of back cabinet to reject dirt and dust at least once a year because of set reliability.
- If using the cooling fan continuously, it's recommended to wipe holes a minimum of once a month.

Immediately unplug your monitor from the wall outlet and refer servicing to qualified service personnel under the following conditions:

- When the power supply cord or plug is damaged.
- If liquid has been spilled, or objects have fallen into the monitor.
- If the monitor has been exposed to rain or water.
- If the monitor has been dropped or the cabinet damaged.
- If the monitor does not operate normally by following operating instructions.

Recommended Use

- For optimum performance, allow 20 minutes for warm-up.
- Rest your eyes periodically by focusing on an object at least 5 feet away. Blink often.
- Position the monitor at a 90° angle to windows and other light sources to minimize glare and reflections.
- Clean the LCD monitor surface with a lint-free, non-abrasive cloth. Avoid using any cleaning solution or glass cleaner!
- Adjust the monitor's brightness, contrast and sharpness controls to enhance readability.
- Avoid displaying fixed patterns on the monitor for long periods of time to avoid image persistence (after image effects).
- Get regular eye checkups.

Ergonomics

To realize the maximum ergonomic benefits, we recommend the following:

- Use the preset Size and Position controls with standard signals.
- Use the preset Color Setting.
- Use non-interlaced signals.
- Do not use primary color blue on a dark background, as it is difficult to see and may produce eye fatigue due to insufficient contrast.

Cleaning the LCD Panel

- When the liquid crystal panel is stained with dust or dirt, please wipe with soft cloth gently.
- Please do not rub the LCD panel with hard material.
- Please do not apply pressure to the LCD surface.
- Please do not use OA cleaner it will cause deterioration or discolor on the LCD surface.

Cleaning the Cabinet

- Unplug the power supply
- Gently wipe the cabinet with a soft cloth
- To clean the cabinet, dampen the cloth with a neutral detergent and water, wipe the cabinet and follow with a dry cloth.

NOTE: The surface of the cabinet is composed of many types of plastic. DO NOT clean with benzene thinner, alkaline detergent, alcoholic system detergent, glass cleaner, wax, polish cleaner, soap powder, or insecticide. Rubber or vinyl should not be in contact with the cabinet for an extended period of time. These types of fluids and materials can cause the paint to deteriorate, crack or peel.

Contents

Your new MultiSync monitor box* should contain the following:

- LCD monitor
- Power Cord*¹
- Video Signal Cable
- Setup Manual
- Wireless Remote Control and AAA Batteries
- Main switch cover
- Clamp x 2
- Screw for clamp (M4 x 8) x 2
- Screw for main switch cover (3 x 10) x 2
- CD-ROM
- Thumbscrew for stand x 2 (LCD4215 only)

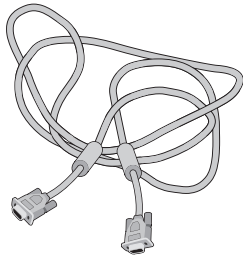

Video Signal Cable
(Mini D-SUB 15 pin to
Mini D-SUB 15 pin)

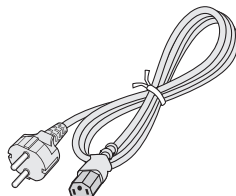

Power Cord*¹



Screw for clamp
(M4 x 8) x 2



Screw for main switch
cover (3 x 10) x 2



Thumbscrew for stand x 2
(LCD4215 only)



Clamp x 2

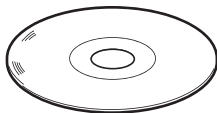

CD-ROM

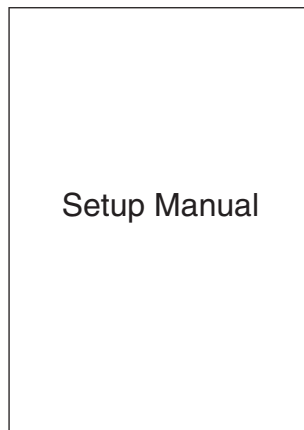

Setup Manual

Setup Manual

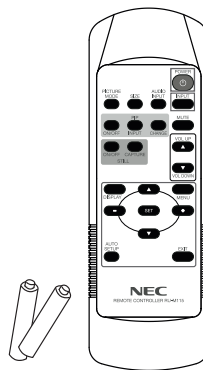

Wireless Remote Control
and AAA Batteries

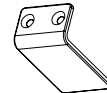

Main switch cover

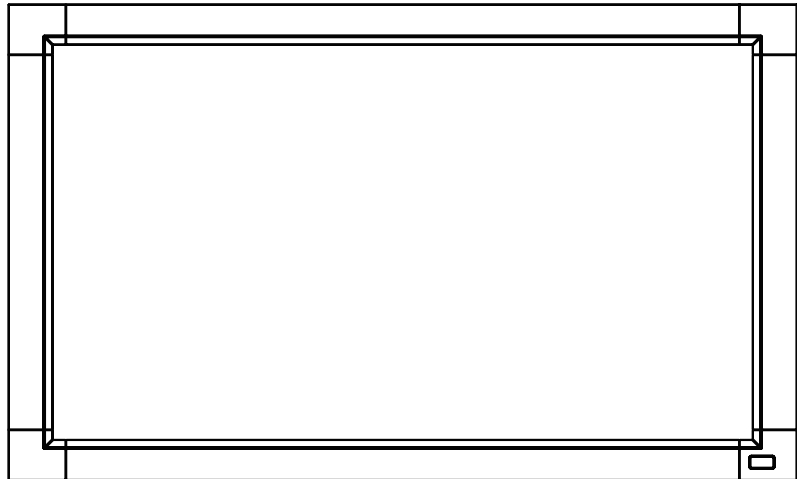

- *¹ Type and number of power cords included will depend on the where the LCD monitor is to be shipped. When more than one power cord is included, please use a power cord that matches the AC voltage of the power outlet and has been approved by and complies with the safety standard of your particular country.
- * Depending on where the LCD is sold, the stand may or may not be included with some models.
- * Remember to save your original box and packing material to transport or ship the monitor.

Installation

This device cannot be used or installed without the Tabletop Stand or other mounting accessory for support. For proper installation it is strongly recommended to use a trained, NEC authorized service person. Failure to follow NEC standard mounting procedures could result in damage to the equipment or injury to the user or installer. Product warranty does not cover damage caused by improper installation. Failure to follow these recommendations could result in voiding the warranty.

Mounting

DO NOT mount the monitor yourself. Please ask dealer. For proper installation it is strongly recommended to use a trained, qualified technician. Please inspect the location where the unit is to be mounted. Mounting on wall or ceiling is the customer's responsibility. Not all walls or ceilings are capable of supporting the weight of the unit. Product warranty does not cover damage caused by improper installation, remodeling, or natural disasters. Failure to comply with these recommendations could result in voiding the warranty.

DO NOT block ventilated openings with mounting accessories or other accessories.

For NEC Qualified Personnel:

To insure safe installation, use two or more brackets to mount the unit. Mount the unit to at least two points on the installation location.

Please note the following when mounting on wall or ceiling

- When using mounting accessories other than those that are NEC approved, they must comply with the VESA-compatible (FDMLv1) mounting method.
- NEC strongly recommends using size M6 screws (9 mm + thickness of bracket in length). If using screws longer than 9 mm, check the depth of the hole. (Recommended Fasten Force: 470 - 635N•cm)
NEC recommends mounting interfaces that comply with UL1678 standard in North America.
- Prior to mounting, inspect the installation location to insure that it is strong enough to support the weight of the unit so that the unit will be safe from harm.
- Refer to the instructions included with the mounting equipment for detailed information.
- Weight of LCD assembly: MultiSync LCD3215: 16.2 Kg (MAX), MultiSync LCD4215: 20.5 Kg (MAX)

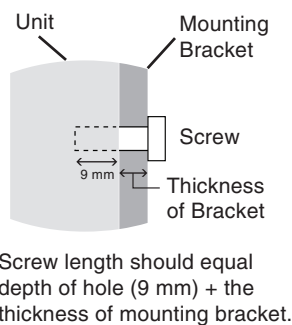

Orientation

- When using the display in the portrait position, the monitor should be rotated clockwise so that the left side is moved to the top and the LED indicator light is on the bottom. This will allow for proper ventilation and will extend the lifetime of the monitor. Improper ventilation may shorten the lifetime of the monitor.

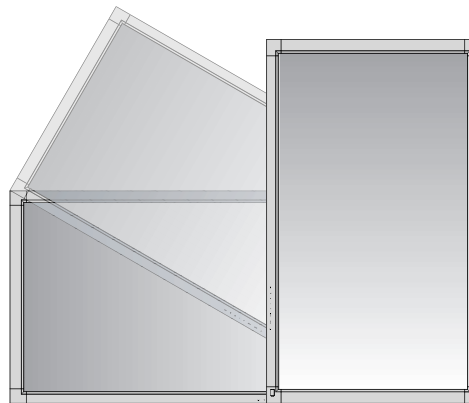

Mounting location

- The ceiling and wall must be strong enough to support the monitor and mounting accessories.
- DO NOT install in locations where a door or gate can hit the unit.
- DO NOT install in areas where the unit will be subjected to strong vibrations and dust.
- DO NOT install near where the main power supply enters the building.
- Do not install in where people can easily grab and hang onto the unit or the mounting apparatus.
- When mounting in a recessed area, as in a wall, leave at least 4 inches (10cm) of space between the monitor and the wall for proper ventilation.
- Allow adequate ventilation or provide air conditioning around the monitor, so that heat can properly dissipate away from the unit and mounting apparatus.

Mounting on ceiling

- Ensure that the ceiling is sturdy enough to support the weight of the unit and the mounting apparatus over time, against earthquakes, unexpected vibrations, and other external forces.
- Be sure the unit is mounted to a solid structure within the ceiling, such as a support beam. Secure the monitor using bolts, spring lock washers, washer and nut.
- DO NOT mount to areas that have no supporting internal structure. DO NOT use wood screws or anchor screws for mounting. DO NOT mount the unit to trim or to hanging fixtures.

Maintenance

- Periodically check for loose screws, gaps, distortions, or other problems that may occur with the mounting apparatus. If a problem is detected, please refer to qualified personnel for service.
- Regularly check the mounting location for signs of damage or weakness that may occur over time.

Attaching Mounting Accessories

The display is designed for use with the VESA mounting system.

1. Attach Mounting Accessories

Be careful to avoid tipping monitor when attaching accessories.

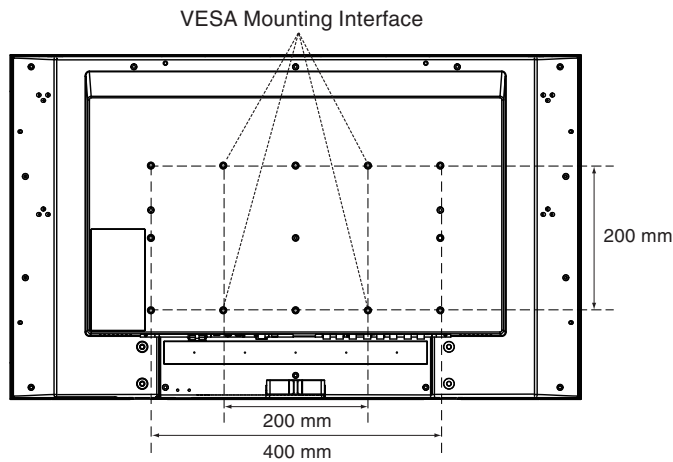

Figure 1

Mounting accessories can be attached with the monitor in the face down position. To avoid damaging the screen face, place the protective sheet on the table underneath the LCD. The protective sheet was wrapped around the LCD in the original packaging. Make sure there is nothing on the table that can damage the monitor.

When using mounting accessories other than NEC compliant and approved, they must comply with the VESA-compatible mounting method.

2. Installing and removing optional table top stand

CAUTION: Installing and removing the stand must be done by two or more people.

To install, follow those instructions included with the stand or mounting apparatus. Use only those devices recommended by the manufacturer.

Handle with care when mounting LCD monitor stand and avoid pinching your fingers.

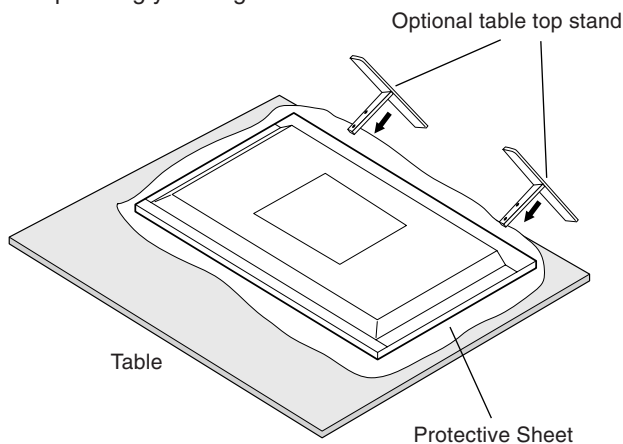

NOTE: Place stand onto monitor so that the long end of the feet are in the front.

3. Ventilation Requirements

When mounting in an enclosed space or recessed area, leave adequate room between the monitor and the enclosure to allow heat to disperse, as shown below.

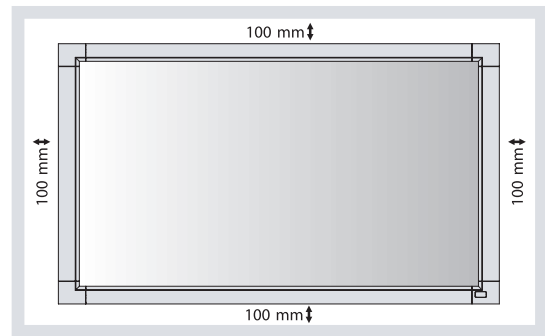

4. Prevent Tipping

When using the display with the Tabletop Stand fasten the LCD to a wall using a cord or chain that can support the weight of the monitor in order to prevent the monitor from falling. Fasten the cord or chain to the monitor using the provided clamp and screw.

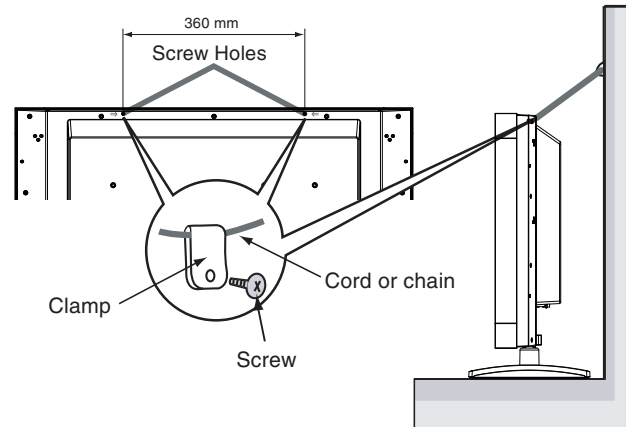

Before attaching the LCD monitor to the wall, make sure that the wall can support the weight of the monitor.

Be sure to remove the cord or chain from the wall before moving the LCD.

Parts Name and Functions

Control Panel

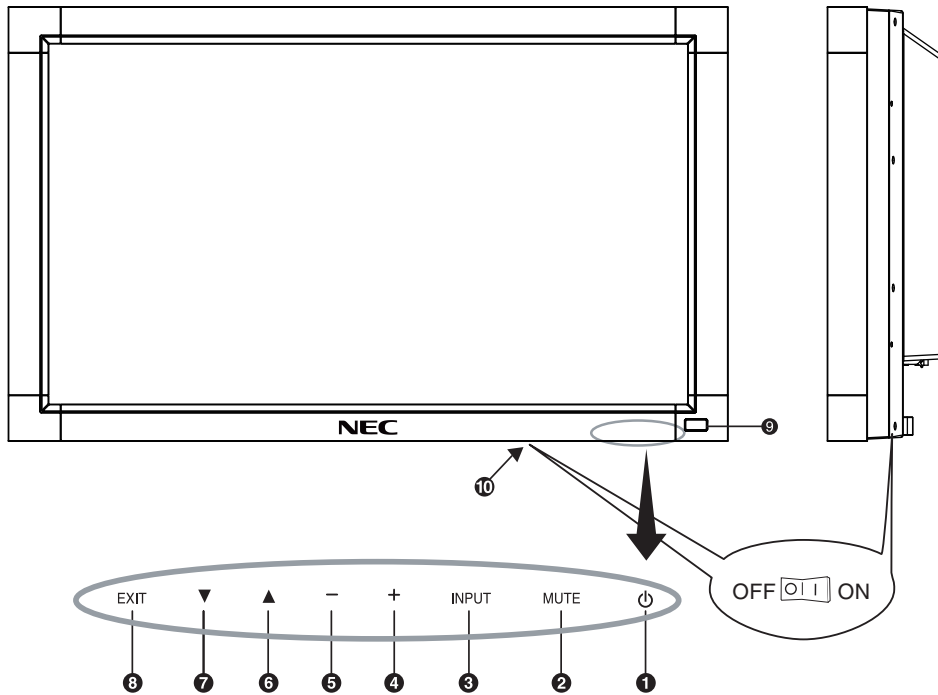

1 POWER button (⏻)

Switches the power on/off. See also page 18.

2 MUTE button

Switches the audio mute ON/OFF.

3 INPUT button

Acts as SET button within OSD menu. Toggle switches between [RGB1], [RGB2], [RGB3], [DVD/HD], [VIDEO(S)] or [VIDEO].

4 PLUS (+) button

Acts as (+) button to increase the adjustment with OSD menu. Increases the audio output level when the OSD menu is turned off.

5 MINUS (-) button

Acts as (-) button to decrease the adjustment with OSD menu. Decreases the audio output level when the OSD menu is turned off.

6 UP (▲) button

Activates the OSD menu when the OSD menu is turned-off. Acts as ▲ button to move the highlighted area up to select adjustment items within OSD menu.

7 DOWN (▼) button

Activates the OSD menu when the OSD menu is turned-off. Acts as ▼ button to move the highlighted area down to select adjustment items within OSD menu.

8 EXIT button

Activates the OSD menu when the OSD menu is turned-off. Acts as EXIT button within the OSD to move to previous menu.

9 Remote control sensor and Power Indicator

Receives the signal from the remote control (when using the wireless remote control). See also page 9. Glows green when the LCD monitor is in active mode. Glows red when the LCD is in POWER OFF mode. When the LCD monitor is in POWER SAVE mode, it will glow both green and red. When SCHEDULE is enabled, it will blink green and glow red. See page 19. When a component failure is detected within the monitor, the indicator will blink red.

10 Main Power Switch

On/Off switch to turn main power ON/OFF. See also page 18.

Control Key Lock Mode

This control completely locks out access to all Control Key functions. To activate the control key lock function, press both ▼ and ▲ and hold down simultaneously for more than 3 seconds. To resume user mode, press both ▼ and ▲ and hold simultaneously for more than 3 seconds.

Terminal Panel

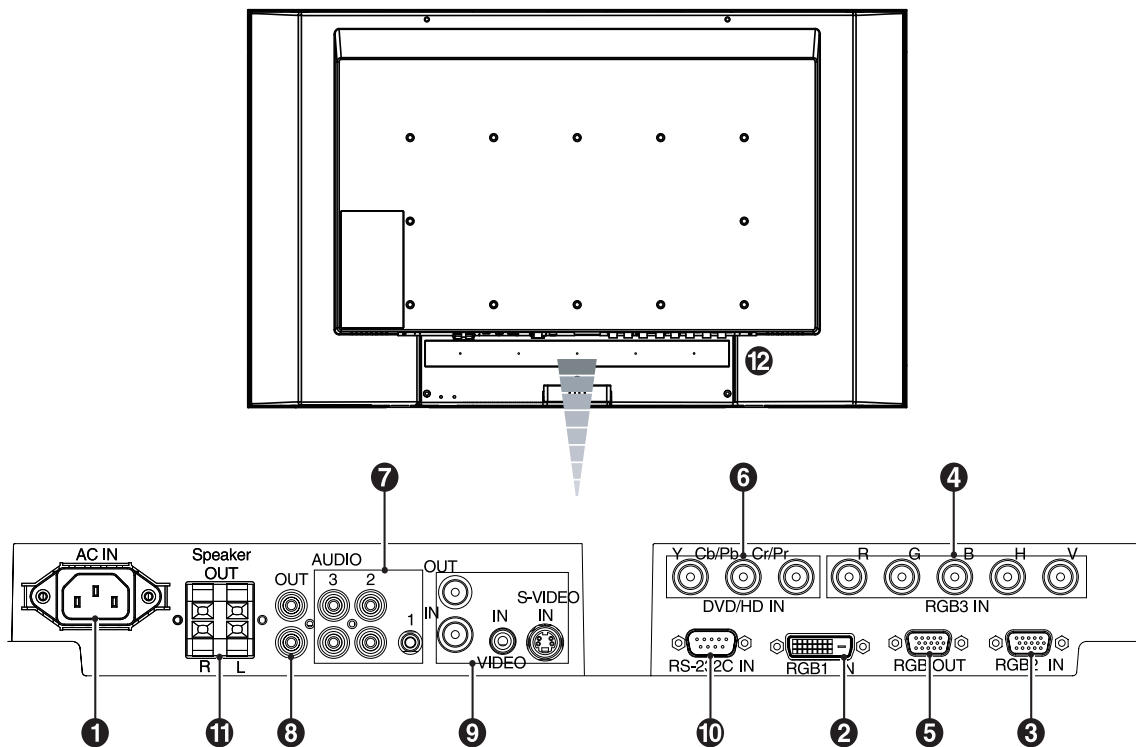

1 AC IN connector

Connects with the supplied power cord.

2 RGB1 IN (DVI-D)

To input digital RGB signals from a computer or HDTV device having a digital RGB output.

* This connector does not support analog input.

3 RGB2 IN (mini D-Sub 15 pin)

To input analog RGB signals from a personal computer or from other RGB equipment.

4 RGB3 IN [R, G, B, H, V] (BNC)

To input analog RGB signals or signals from other RGB equipment.
This is also to connect equipment such as a DVD player, HDTV device and Set-Top-Box.

5 RGB OUT (mini D-Sub 15 pin)

To outputs the signal from the RGB/HV IN connector to an input on a separate device.

6 DVD/HD IN [Y, Pb/Cb, Pr/Cr] (BNC)

Connecting equipment such as a DVD player, HDTV device, or Set-Top-Box.

7 AUDIO IN 1, 2, 3

To input audio signal from external equipment such as a computer, VCR or DVD player.

8 AUDIO OUT

To output the audio signal from the AUDIO IN 1, 2 and 3 jack to an external device (stereo receiver, amplifier, etc.).

9 VIDEO INPUT/OUTPUT Connector

VIDEO IN connector (BNC and RCA): To input a composite video signal. BNC and RCA connectors are not available at the same time (Use only one input).

VIDEO OUT connector (BNC): To output the composite video signal from the VIDEO IN connector.

VIDEO(S) IN connector (Mini DIN 4 pin): To input the VIDEO(S) (Y/C separate signal).

10 EXTERNAL CONTROL (D-Sub 9 pin)

Connect RS-232C input from external equipment such as a PC in order to control RS-232C functions.

11 EXTERNAL SPEAKER TERMINAL

To output the audio signal from AUDIO 1, 2, 3.

Note: This speaker terminal is for optional speaker. SP-3215 for MultiSync LCD3215, SP4020-4620 for MultiSync LCD4215.

12 Kensington Lock (LCD4215 only)

For security and theft prevention.

Wireless Remote Control

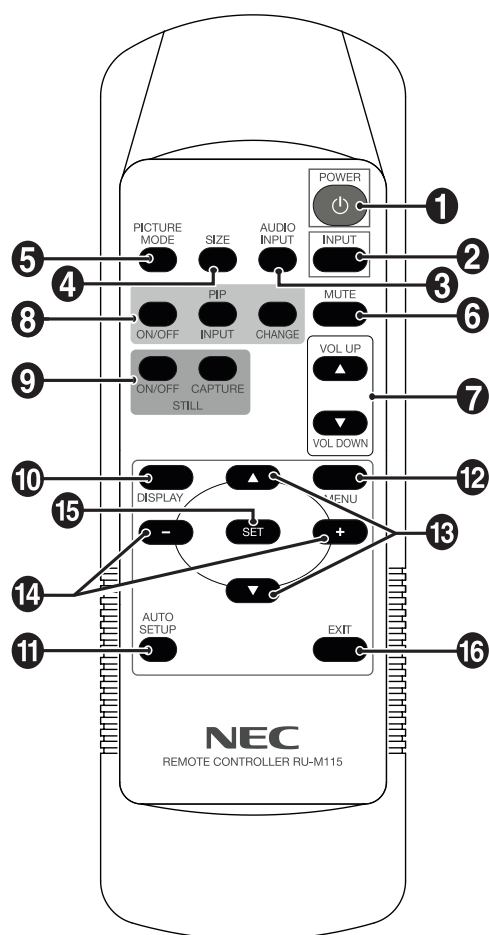

1 POWER button

Switches the power on/off.

2 INPUT button

Selects input signal, [RGB1], [RGB2], [RGB3], [DVD/HD], [VIDEO(S)] or [VIDEO].

3 AUDIO INPUT button

Selects audio input source [AUDIO:1], [AUDIO:2], [AUDIO:3].

4 SIZE button

Selects picture size, [FULL], [NORMAL], [CUSTOM], [DYNAMIC] and [REAL]. See page 19.

5 PICTURE MODE button

Selects picture mode, [HIGHBRIGHT], [STANDARD], [sRGB], [CINEMA]. See page 19.

HIGHBRIGHT: for moving images such as DVD
 STANDARD: for images
 sRGB: for text based images
 CINEMA: for movies.

6 MUTE button

Turns on/off mute function.

7 VOLUME UP/DOWN button

Increases or decreases audio output level.

8 PIP (Picture In Picture) button

ON/OFF button: Toggle switches between PIP and POP. See page 22.

INPUT button: Selects the "picture in picture" input signal.

CHANGE button: Replaces to the main picture and sub picture.

NOTE: The "PIP" and "POP" modes do not function when the screen size is "CUSTOM" or "REAL".

		Sub picture					
		RGB1	RGB2	RGB3	DVD/HD	VIDEO(S)	VIDEO
Main picture	RGB1	-	-	-	-	✓	✓
	RGB2	-	-	-	-	✓	✓
	RGB3	-	-	-	-	✓	✓
	DVD/HD	-	-	-	-	✓	✓
	VIDEO(S)	✓	✓	✓	✓	-	-
	VIDEO	✓	✓	✓	✓	-	-

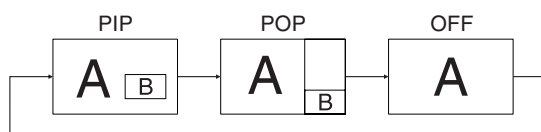

9 STILL button

ON/OFF button: Activates/deactivates still picture mode.

STILL CAPTURE button: Captures still picture.

10 DISPLAY button

Turns on/off the information OSD. See page 19.

11 AUTO SETUP button

Enters auto setup menu. See page 21.

12 MENU button

Turns on/off the menu mode.

13 UP/DOWN button

Acts as ▲ ▼ button to move the highlighted area up or down to select adjustment items within OSD menu.

Small screen which adjusted "PIP" mode moves up or down.

14 MINUS/PLUS (+/-) button

Increases or decreases the adjustment level within OSD menu settings.

Small screen which adjusted "PIP" mode moves left or right.

15 SET button

Makes selection.

16 EXIT button

Returns to previous menu within OSD menu.

Operating Range for the Remote Control

Point the top of the remote control toward the LCD monitor's remote sensor during button operation.

Use the remote control within a distance of about 7 m (23 ft.) from the front of the LCD monitor's remote control sensor or at a horizontal and vertical angle of within 30° within a distance of about 3.5 m (10 ft.)

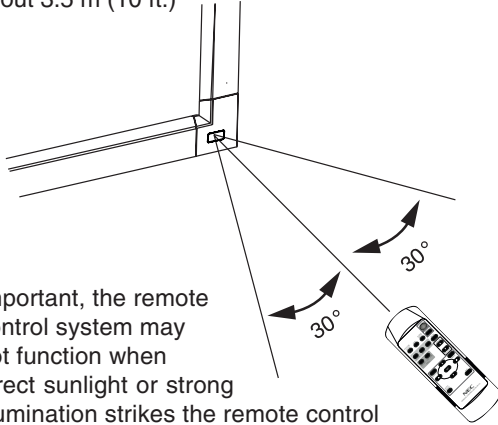

Caution: Important, the remote control system may not function when direct sunlight or strong illumination strikes the remote control sensor of the LCD monitor, or when there is an object in the path.

Handling the remote control

- Do not subject to strong shock.
- Do not allow water or other liquid to splash the remote control. If the remote control gets wet, wipe it dry immediately.
- Avoid exposure to heat and steam.
- Other than to install the batteries, do not open the remote control.

1. Determine the installation location

CAUTION: Installing your LCD display must be done by a qualified technician. Contact your dealer for more information.

CAUTION: MOVING OR INSTALLING THE LCD MONITOR MUST BE DONE BY TWO OR MORE PEOPLE. Failure to follow this caution may result in injury if the LCD monitor falls.

CAUTION: Do not mount or operate the display upside down, face up, or face down.

CAUTION: This LCD has a temperature sensor and cooling fan. If the LCD becomes too hot, the cooling fan will turn on automatically. If the LCD becomes overheated while the cooling fan is running, a "Caution" warning will appear. If the "Caution" warning appears, discontinue use and allow the unit to cool. Using the cooling fan will reduce the likelihood of early circuit failure and may help reduce image degradation and "Image Persistence".

If the LCD is used in an enclosed area or if the LCD panel is covered with a protective screen, please check the inside temperature of the monitor by using the "HEAT STATUS" control in the OSD (see page 23). If the temperature is higher than the normal operating temperature, please turn the cooling fan to ON within the SCREEN SAVER menu within the OSD (see page 23).

IMPORTANT: Lay the protective sheet, which was wrapped around the LCD monitor when it was packaged, beneath the LCD monitor so as not to scratch the panel.

2. Install the remote control batteries

The remote control is powered by two 1.5V AAA batteries. To install or replace batteries:

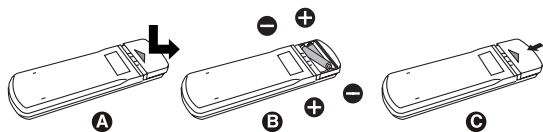

- Press and slide to open the cover.
- Align the batteries according to the (+) and (-) indications inside the case.
- Replace the cover.

CAUTION: Incorrect usage of batteries can result in leaks or bursting.

NEC recommends the following battery use:

- Place "AAA" size batteries matching the (+) and (-) signs on each battery to the (+) and (-) signs of the battery compartment.
- Do not mix battery brands.
- Do not combine new and old batteries. This can shorten battery life or cause liquid leakage of batteries.
- Remove dead batteries immediately to prevent battery acid from leaking into the battery compartment.
- Do not touch exposed battery acid, it may injure skin.

NOTE: If you do not intend to use the Remote Control for a long period of time, remove the batteries.

3. Connect external equipment (See pages 13-17)

- To protect the external equipment; turn off the main power before making connections.
- Refer to your equipment user manual for further information.

4. Connect the supplied power cord

- The equipment should be installed close to an easily accessible power outlet.
- Fully insert the prongs into the power outlet socket. A loose connection may cause image degradation.

NOTE: Please refer to the "Safety Precautions and Maintenance" section of this manual for proper selection of AC power cord.

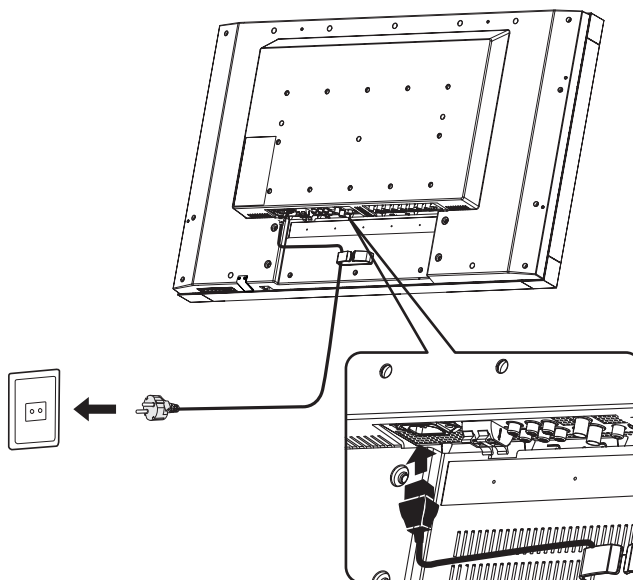

5. Switch on the power of all the attached external equipment

When connected with a computer, switch on the power of the computer first.

6. Operate the attached external equipment

Display the signal from the desired input source.

7. Adjust the sound

Make volume adjustments when required.

8. Adjust the screen (See pages 21 and 22)

Make adjustments of the screen display position when necessary.

9. Adjust the image (See page 21)

Make adjustments such as brightness or contrast when required.

10. Recommended Adjustments

To reduce the risk of the "Image Persistence", please adjust the following items based on the application being used: "POWER SAVE", "SCREEN SAVER", "SIDE BORDER COLOR" (See page 23) "DATE & TIME", "SCHEDULE" (See page 22).

11. To prevent the main power switch from being changed

To prevent use of the main power switch, please attach the main switch cover, which is enclosed as an accessory.

NOTE: With the main power switch cover in place, the main power switch cannot be turned off. Remove main power switch cover in order to switch off the display.

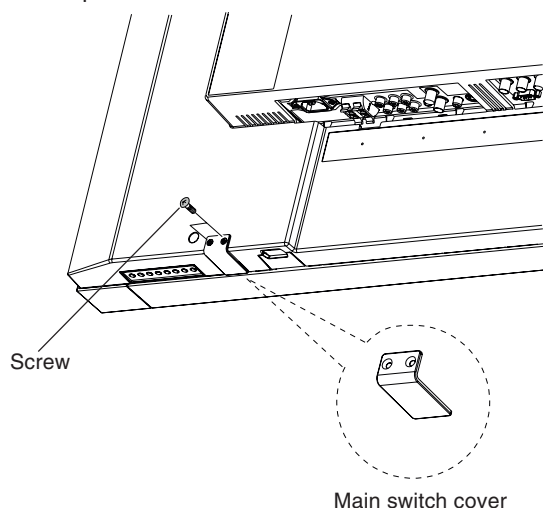

Connections

Before making connections:

- * First turn off the power of all the attached equipment and make connections.
- * Refer to the user manual included with each separate piece of equipment.

Wiring Diagram

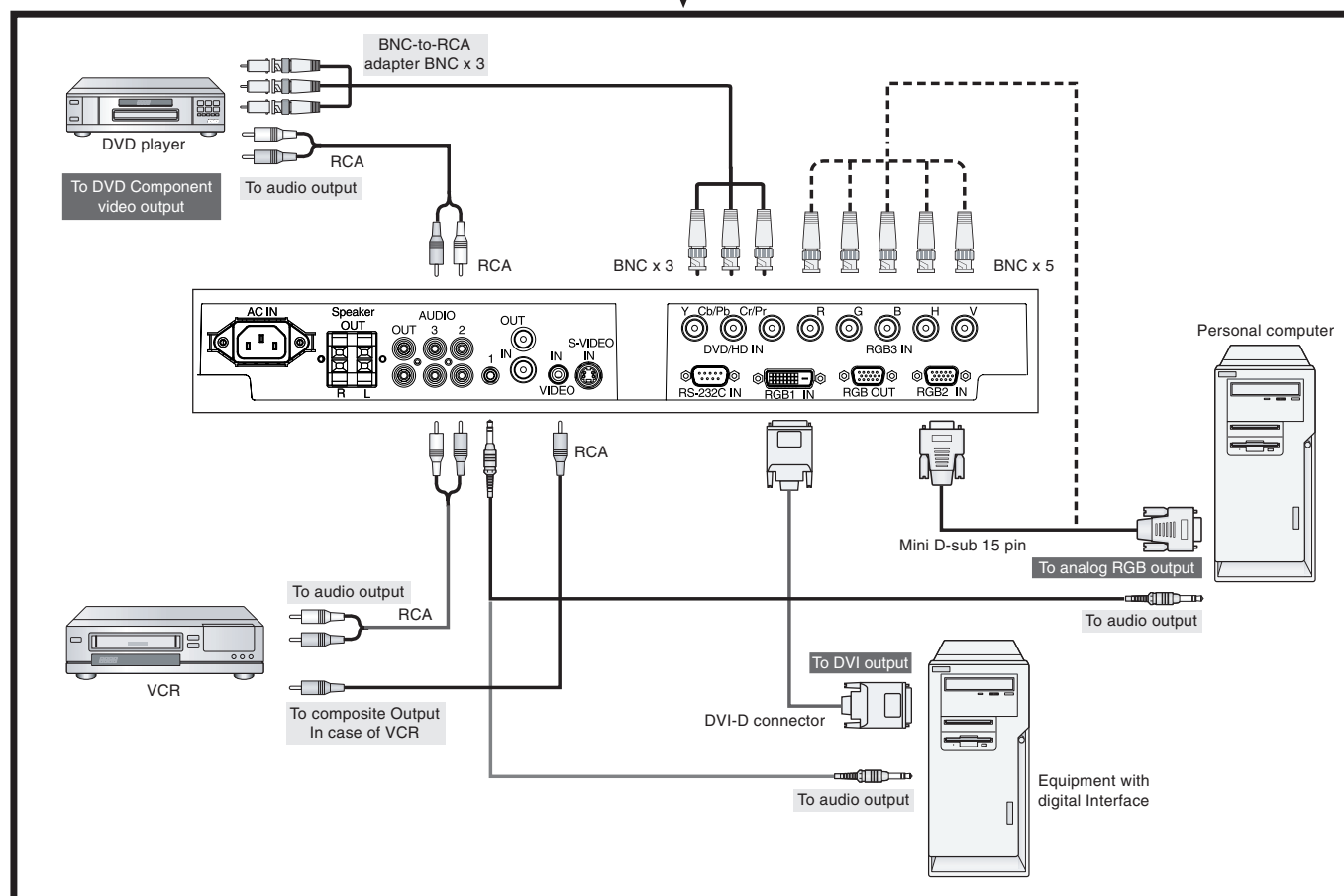
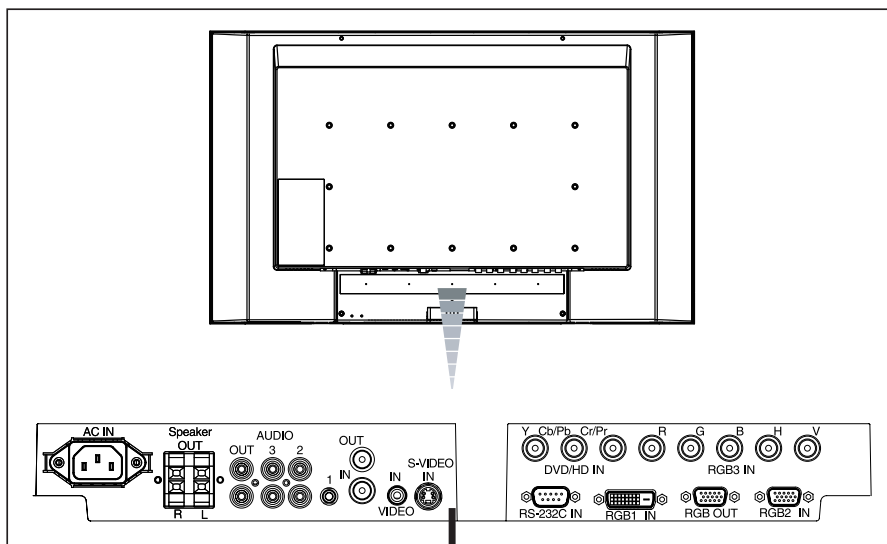

Connecting a Personal Computer

Connecting your computer to your LCD monitor will enable you to display your computer's screen image. Some video cards and a pixel clock over 165MHz may not display an image correctly. Your LCD monitor displays proper image by adjusting the factory preset timing signal automatically.

<Factory preset signal timing>

Resolution	Scanning frequency		Remarks
	Horizontal	Vertical	
640 x 480	31.5kHz	60Hz	
800 x 600	37.9kHz	60Hz	
1024 x 768	48.4kHz	60Hz	
1280 x 768	48kHz	60Hz	
1360 x 768	48kHz	60Hz	Recommended resolution
1280 x 1024	64kHz	60Hz	Compressed image
1600 x 1200	75kHz	60Hz	Compressed image

Connect the LCD Monitor to a Personal Computer

- To connect the RGB2 connector (mini D-sub 15 pin) on the LCD monitor, use the supplied PC - Video RGB signal cable (mini D-sub 15 pin to mini D-sub 15 pin).
- To connect the RGB3 connector (BNC) on the LCD monitor, use a mini D-sub 15 pin to BNC x 5 signal cable (sold separately). Select RGB3 from the INPUT button.
- When connecting one or more LCD monitors, use the RGB OUT connector (mini D-sub 15 pin) (BNC INPUT only).
- AUDIO IN 1, 2 and 3 can be used for audio input. To select audio source [AUDIO:1], [AUDIO:2] or [AUDIO:3] press the AUDIO INPUT button.

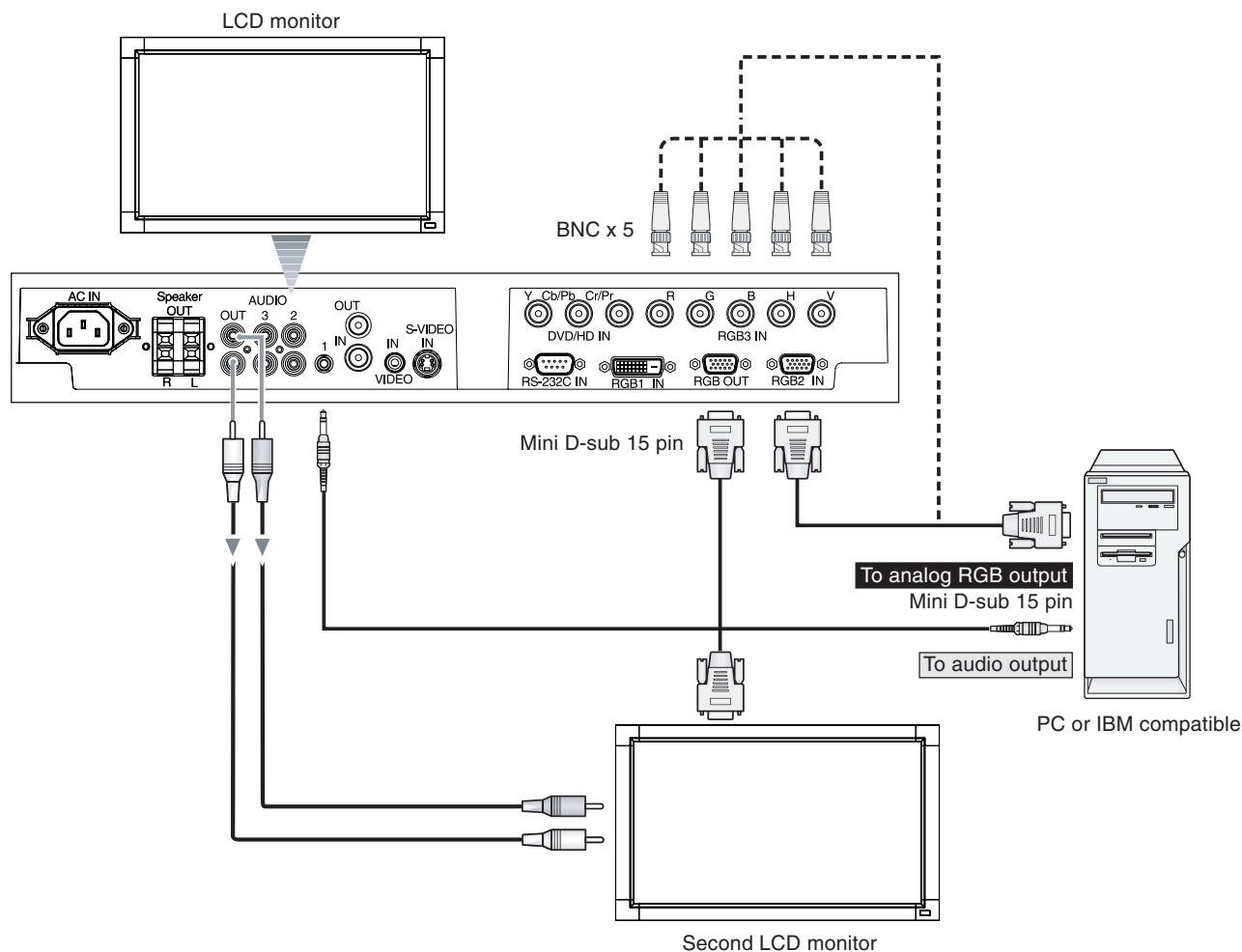

Connecting with Digital Interface Equipment

Connections can be made with equipment that is equipped with a digital interface that complies with the DVI (Digital Visual Interface) standard.

Connect the LCD Monitor to a Computer with a Digital Output

- The RGB1 connector also accepts a DVI-D cable.
- Input TMDS signals conforming to DVI standards.
- To maintain display quality, use a cable that conforms to DVI standards.
- AUDIO IN 1, 2 and 3 can be used for audio input. To select audio source [AUDIO:1], [AUDIO:2] or [AUDIO:3] press the AUDIO INPUT button.
- For mode selection, see "DVI MODE" on page 24.

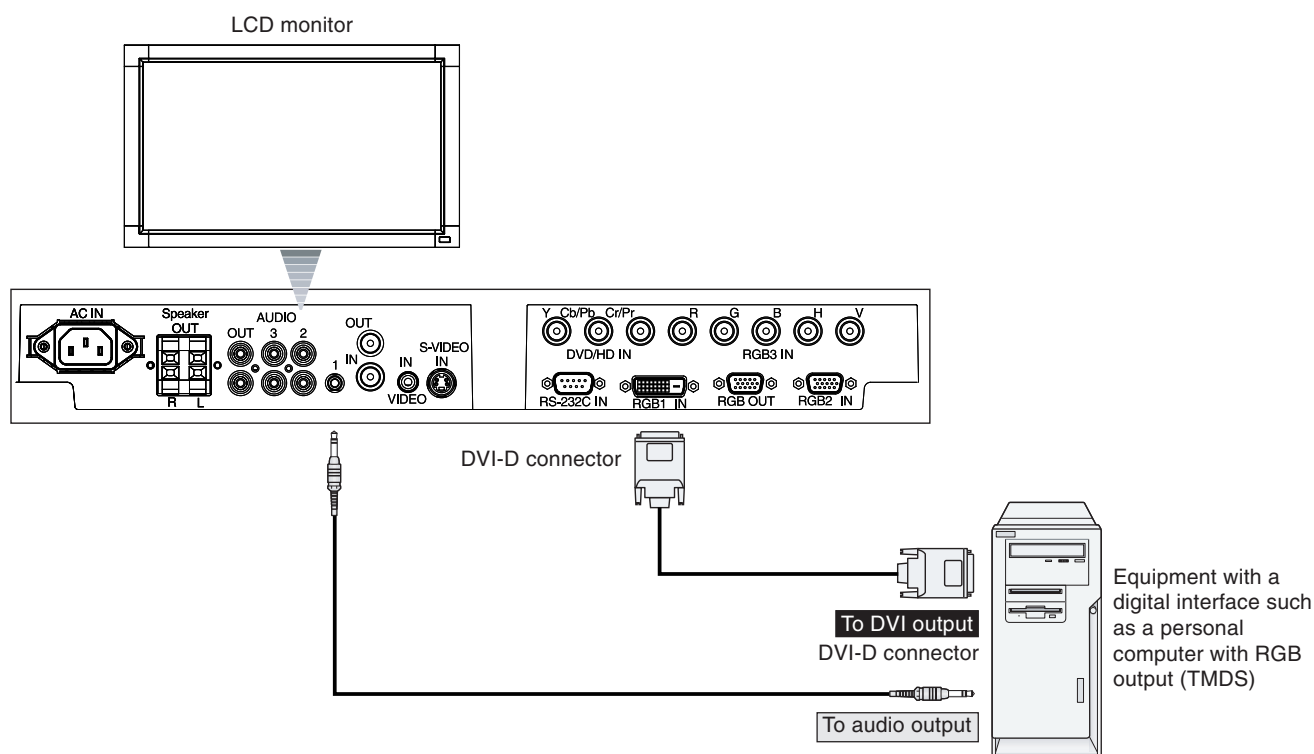

Connecting a DVD Player with component out

Connecting your DVD player to your LCD monitor will enable you to display DVD video.

Refer to your DVD player user's manual for more information.

Connect the LCD Monitor to a DVD Player

- To connect the DVD/HD IN connector (BNC) on the LCD monitor, use an BNC connector cable (sold separately). Some DVD players may have different connectors such as DVI-D connector. Select [DVI/HD] mode from the "DVI MODE" menu. For mode selection, see "DVI MODE" on page 24. AUDIO IN 1, 2 and 3 can be used for audio input. To select audio source [AUDIO:1], [AUDIO:2] or [AUDIO:3] press the AUDIO INPUT button.

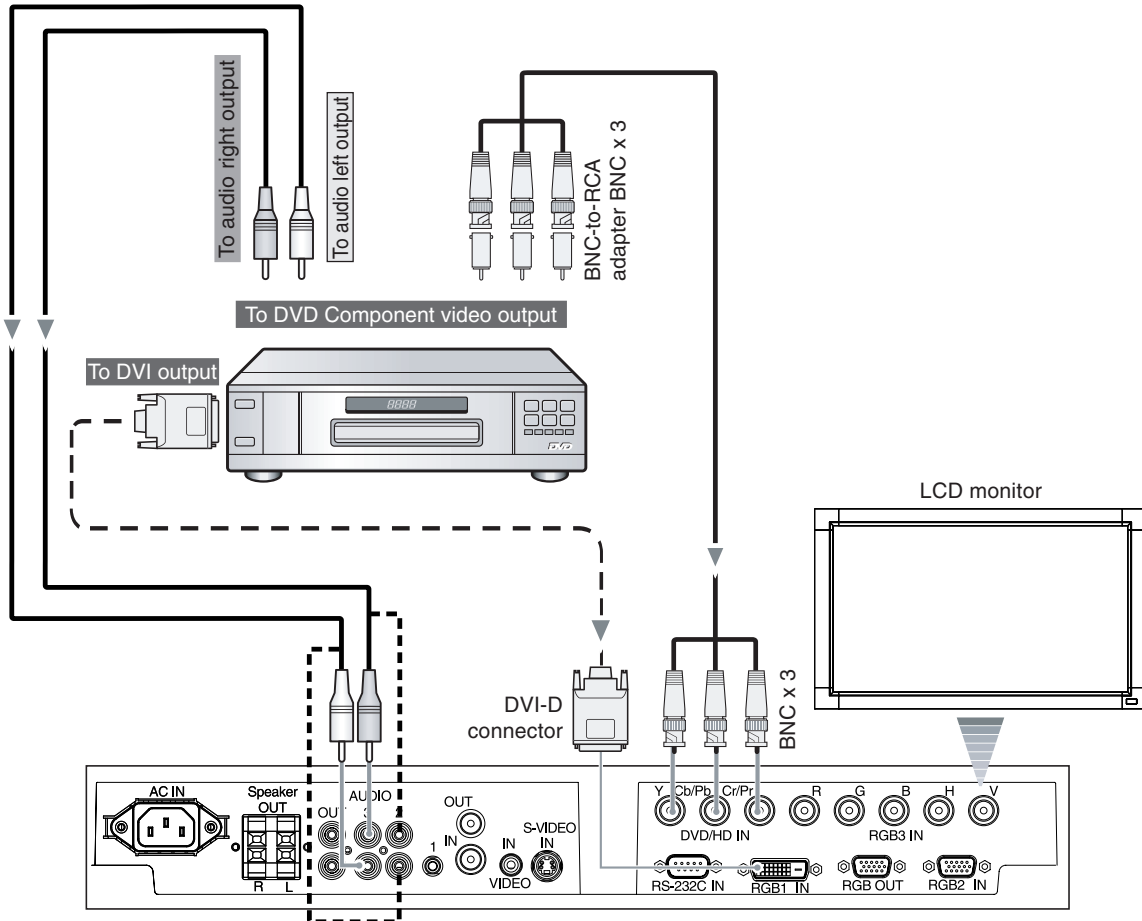

Connecting to a Stereo Amplifier

You can connect your stereo amplifier to your LCD monitor. Refer to your amplifier owner's manual for more information.

Connect the LCD Monitor to a Stereo Amplifier

- Turn on the LCD monitor and the amplifier only after all connections have been made.
- Use a stereo Mini-RCA cable to connect the AUDIO OUT connector (Stereo Mini Jack) on the LCD monitor to the audio input on the amplifier.
- Do not reverse the audio left and right jacks.
- The AUDIO IN is used for audio input.
- The AUDIO OUT jack outputs sound from the selected Audio input.

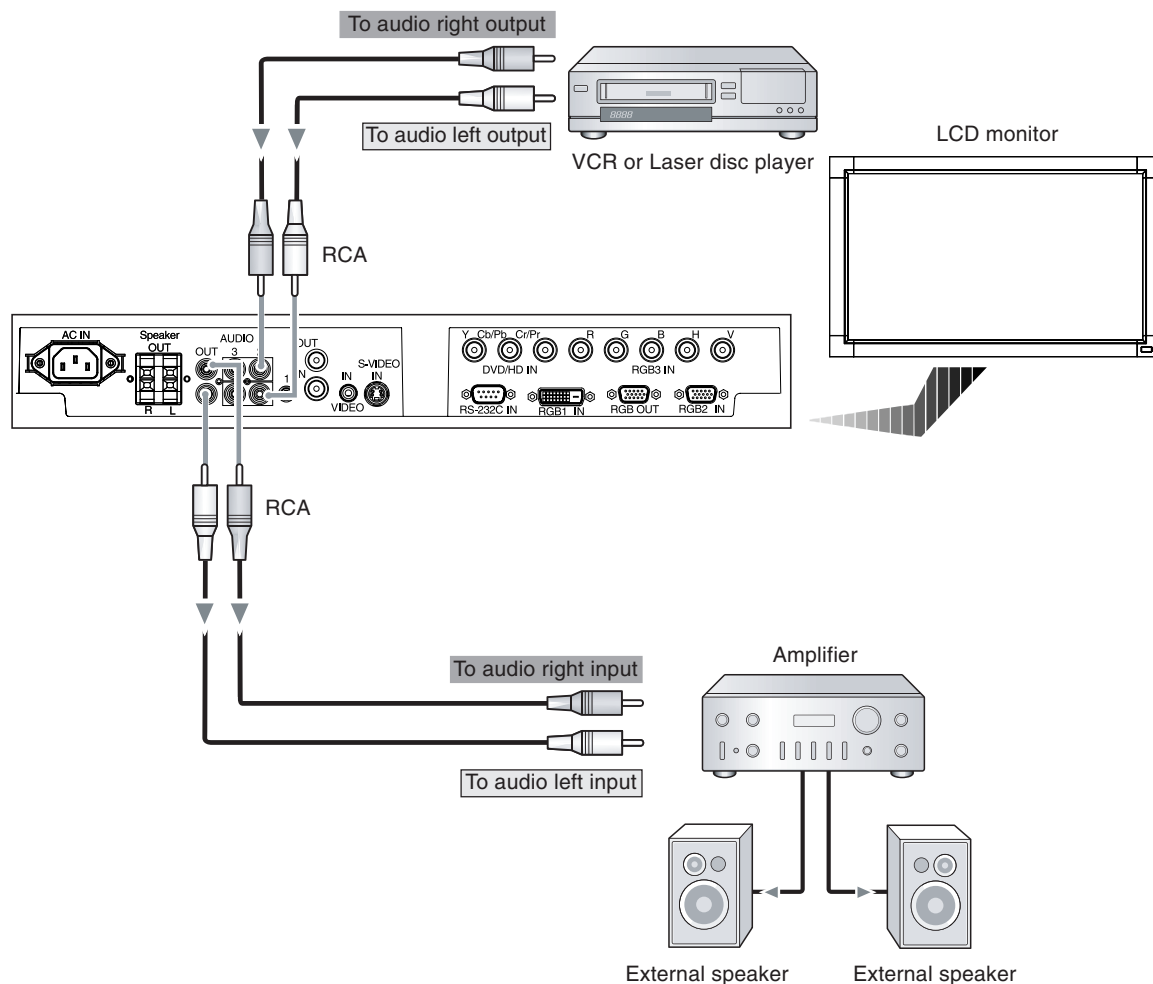

Basic Operation

Power ON and OFF Modes

The LCD monitor power indicator will turn green while powered on and will turn red while powered off.

NOTE: The Main Power Switch must be in the ON position in order to power up the monitor using the remote control or the Power Button on the front of the LCD.

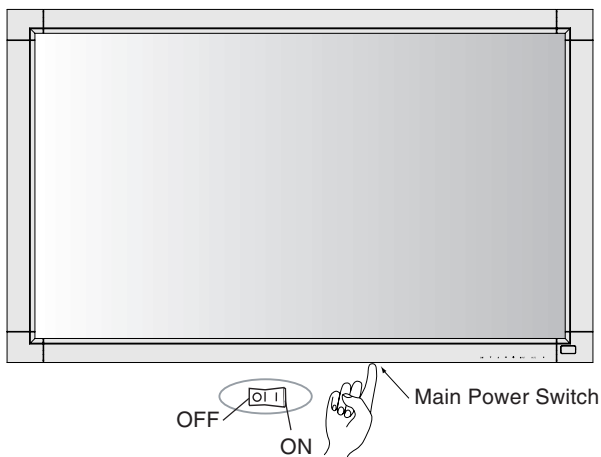
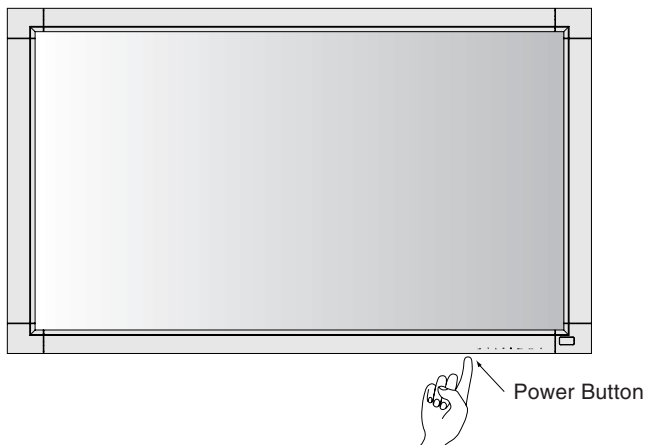

Using the remote control

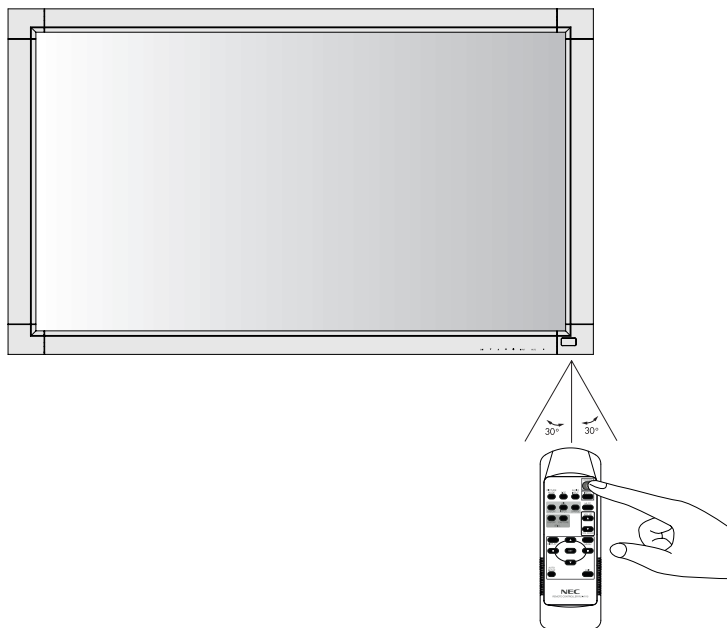

Power Indicator

	Status
Power ON	Green
Power OFF	Red
Power Standby when "SCHEDULE" is enabled	Red On Green Blinking
Power Standby	Red, Green
Diagnosis (Detecting failure)	Red Blinking
	* See troubleshooting on page 28

Using Power Management

The LCD monitor follows the VESA approved DPM Power Management function.

The power management function is an energy saving function that automatically reduces the power consumption of the display when the keyboard or the mouse has not been used for a fixed period.

The power management feature on your new display has been set to the "ON" mode. This allows your display to enter a Power Saving Mode when no signal is applied. This could potentially increase the life and decrease the power consumption of the display.

Selecting a video source

To view a video source:

Use the input button to set [VIDEO(S)] or [VIDEO].

Use the COLOR SYSTEM menu to set [AUTO], [NTSC], [PAL], [SECAM], [PAL60], [4.43NTSC], according to your video format.

Picture Size

RGB1, RGB2, RGB3

FULL → NORMAL → CUSTOM → REAL

DVD/HD, VIDEO(S), VIDEO

FULL → NORMAL → DYNAMIC → CUSTOM → REAL

Aspect ratio of image	Unchanged view*1	Recommended selection for picture size*1
4:3		NORMAL
		DYNAMIC
Squeeze		FULL

*1 Grey areas indicate unused portions of the screen.

NORMAL: Displays the aspect ratio the same as it is sent from the source.

FULL: Fills entire screen.

DYNAMIC: Expands a 4:3 pictures to fill the entire screen with non-linearity. Some of the outside image area will be cut off due to expansion.

CUSTOM (ZOOM)

The image can be expanded beyond the active display area. The image which is outside of active display area is not shown.

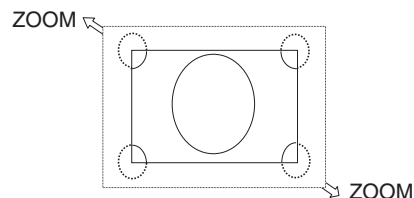

REAL: Image will be displayed 1 by 1 pixel.

Picture Mode

RGB1, RGB2, RGB3 STANDARD → sRGB → HIGHBRIGHT
 DVD/HD, VIDEO(S) STANDARD → CINEMA → HIGHBRIGHT

Information OSD

RGB1, 2, 3

RGB2
 1024 x 768
 48kHz 60Hz
 AUDIO : 1
 SIZE : FULL

- ← Video Input mode
- ← Input signal Information
- ← Audio input mode
- ← Picture Size mode

DVD/HD

DVD/HD
 AUDIO : 3
 SIZE : WIDE

- ← Video Input mode
- ← Audio input mode
- ← Picture Size mode

VIDEO

VIDEO(S)
 NTSC
 AUDIO : 3
 SIZE : NORMAL

- ← Video Input mode
- ← Input Signal Colour System mode
- ← Audio input mode
- ← Picture Size mode

PIP or POP

Main:RGB2
 Sub:VIDEO(S)

RGB2
 1024 x 768
 48kHz 60Hz
 AUDIO : 1
 VIDEO(S)
 NTSC
 SIZE : FULL

- ← Main picture Information
- ← Sub picture Information
- ← Main picture Information

OSD (On-Screen-Display) Controls

Remote Control

Press MENU button to open Main menu.

Press "+", "-" button to select Sub menu, and press Up, Down button to enter Sub menu.

Press SET Button to enter next menu to adjust.

Press Up, Down or "+", "-" button to select function, or setting to be adjusted.

Press MENU or EXIT button to exit.

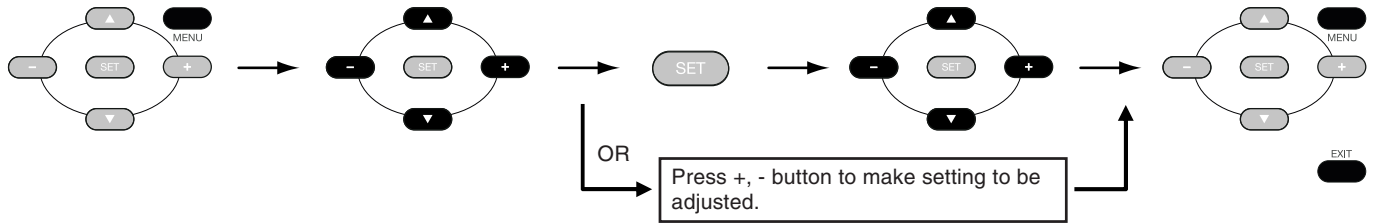

Control Panel

Press EXIT button to open Main menu and press "+", "-" button to select Sub menu. Then press Up, Down button to enter Sub menu.

Press INPUT button to enter next menu to adjust.

Press Up, Down or "+", "-" button to select function, or setting to be adjusted.

Press EXIT button to exit.

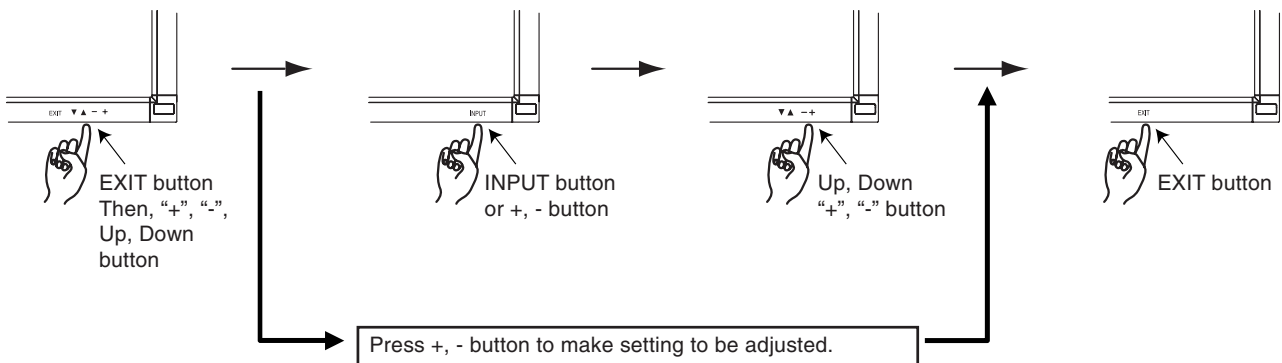

OSD screen

Main menu icon

Main menu

Sub menu

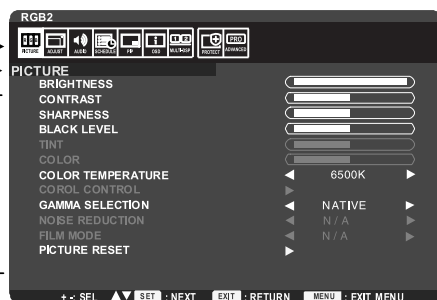

Press MENU button to open Main menu.
Press +, - button to select Sub menu.

Press down or up button to enter Sub menu.

OR

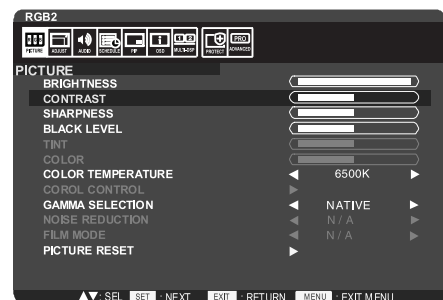

Press SET button to enter next menu to adjust.

Press +, - button to make setting to be adjusted.

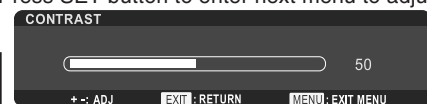

Press Up, Down or "+", "-" button to select function or setting to be adjusted.

Press MENU or EXIT button to exit.

Setting

PICTURE	
BRIGHTNESS	Adjusts the overall image and background brightness.
CONTRAST	Adjusts the image brightness in relation to the input signal. NOTE: sRGB picture mode is standard and cannot be changed.
SHARPNESS	Adjusts the crispness of the image.
BLACK LEVEL	Adjusts the image brightness in relation to the background.
TINT INPUT DVD/HD, VIDEO(S), VIDEO only	Adjusts the tint of the screen.
COLOR INPUT DVD/HD, VIDEO(S), VIDEO only	Adjusts the color depth of the screen.
COLOR TEMPERATURE	Color temperature can be selected out of NATIVE, 9300K, USER, 6500K and 5000K. When USER is selected, R.G.B can be adjusted individually. (RGB 1,2,3 only)
COLOR CONTROL INPUT RGB1, 2, 3 only	Adjusts the levels of the Red, Green, Blue and Saturation. NOTE: It can be adjusted only when USER is selected by COLOR TEMPERATURE.
USER-R	Adjusts the level of RED.
USER-G	Adjusts the level of GREEN.
USER-B	Adjusts the level of BLUE.
GAMMA SELECTION	Select a display gamma for best picture quality.
NATIVE	Gamma correction is handled by the LCD panel.
2.2	Typical display gamma for use with a PC.
2.4	Good for video (TV, DVD, etc.)
S GAMMA	Special gamma for certain types of movies. Raises the dark parts and lowers the light parts of the image. NOTE: sRGB picture is standard and cannot be changed.
NOISE REDUCTION INPUT VIDEO(S), VIDEO only	Adjusts the amount of noise reduction.
FILM MODE INPUT DVD/HD, VIDEO(S), VIDEO only	Selects Film mode function. (AUTO) This mode is better suited for movies, which is converted 24 Frames/sec source to DVD Video.
PICTURE RESET	Resets the all settings within the PICTURE menu back to factory setting.
ADJUST	
AUTO SETUP INPUT RGB2, 3 only	Press "SET" button to automatically adjust screen size, horizontal position, vertical position, clock, clock phase, white level and black level.
AUTO ADJUST INPUT RGB2, 3 only	Selecting ON when changing the timing, the horizontal position, vertical position and clockphase will adjust automatically.
H POSITION	Controls the horizontal position of the image within the Display area of the LCD. Press + to move right. Press - to move left.
V POSITION	Controls the vertical position of the image within the Display area of the LCD. Press + to move up. Press - to move down.
CLOCK INPUT RGB2, 3 only	Press + to expand the width of the image on the right of the screen. Press - to narrow the width of the image on the left.
CLOCK PHASE INPUT RGB2, 3 only	Adjusts the visual "noise" on the image.
ZOOM MODE	You can select "FULL", "NORMAL", "DYNAMIC", "CUSTOM" and "REAL". NOTE: DYNAMIC is INPUT DVD/HD, VIDEO(S), VIDEO only. Selecting DYNAMIC expands 4:3 picture to fill the screen. Some of the image is lost due to expansion. Selecting "REAL" image will be displayed 1 by 1pixel.

CUSTOM ZOOM	"CUSTOM ZOOM" will be selected when you select "CUSTOM" on the screen "ZOOM" mode.
ZOOM	Expands the horizontal and the vertical size simultaneously.
H ZOOM	Expands the horizontal size only.
V ZOOM	Expands the vertical size only.
H POS	Moves to the right with + button. Moves to the left with - button.
V POS	Moves up with + button. Moves down with - button.
H RESOLUTION INPUT RGB1, 2, 3 only	Adjusts the horizontal size of the image. Press + button to expand, and press - button to narrow the width of the image on the screen.
V RESOLUTION INPUT RGB1, 2, 3 only	Adjusts the vertical size of the image. Press + button to expand, and press - button to narrow the width of the image on the screen.
INPUT RESOLUTION INPUT RGB2, 3 only	Selects to decision of input signal timings 1024x768, 1280x768 and 1360x768, if there is a detection problem. If no problem is detected, the only available option will be "AUTO".
ADJUST RESET	Resets the all settings within the ADJUST menu back to factory setting.
AUDIO	
BALANCE	Adjust the balance of L/R volume.
TREBLE	To accentuate or reduce the high frequency sound. Press + to increase, press - to decrease.
BASS	To accentuate or reduce the low frequency sound. Press + to increase, press - to decrease.
AUDIO RESET	Resets the all settings within the AUDIO menu back to factory setting.
SCHEDULE	
OFF TIMER	Sets the monitor to power off after a length of time. A time between 1 to 24 hours is available.
SCHEDULE	Creates a working schedule for the monitor to use. This OSD can't remove except EXIT. (See "NOTE 1" on page 25 for further information).
DATE AND TIME	Sets the date, time, and daylight saving region. Setting item: YEAR/MONTH/DAY/HOUR/MINUTE/DAYLIGHT SAVING TIME Date & time must be set in order for the "SCHEDULE" function to operate.
SCHEDULE RESET	Resets the all settings within the AUDIO menu back to factory setting except DATE AND TIME setting.
PIP	
PIP SIZE	Selects the size of sub-picture used in "Picture-in-Picture" (PIP) mode. "Large", "Middle" and "Small" are available.
PIP AUDIO	Selects the sound source in PIP mode.
PIP RESET	Resets the all settings within the PIP menu back to factory setting.
OSD	
LANGUAGE	Selects the language used by the OSD from seven languages. ENGLISH/DEUTSCH/FRANÇAIS/ESPAÑOL/ITALIANO/SVENSKA/日本語
OSD TURN OFF	Turns off the OSD after a period of inactivity. The preset choices are 5 - 120 seconds.
OSD V-POSITION	Adjusts the vertical position of the OSD menu.
OSD H-POSITION	Adjusts the horizontal position of the OSD menu.
INFORMATION OSD	Selects the information OSD displays or not. The information OSD will display when input signal or source change or warning message like as no-signal or out-of range. A time between 1 to 10 seconds is available.
MONITOR INFORMATION	Indicates the model and serial number of your monitor.
OSD RESET	Resets the all settings within the OSD menu back to factory setting.

MULTI DISPLAY	
IR CONTROL	Selects the infrared wireless remote controller mode. The item in this menu will become effective by pressing "SET" button on the selected item.
NORMAL	The monitor will be controlled normally by wireless remote controller.
LOCK	Disables the monitor control by infrared wireless remote controller. Keep pressing "DISPLAY" button during 5 sec or more, this setting will return to "NORMAL".
TILE MATRIX	Allows one image to be expanded and displayed over multiple screens (up to 16) through a distribution amplifier.
H MONITORS	Selects number of monitors arranged vertically.
V MONITORS	Selects number of monitors arranged horizontally.
POSITION	Selects which section of the tiled image to be displayed on the monitor.
TILE COMP	Turns the TILE COMP feature on.
ENABLE	Enables the Tile Matrix. PIP and STILL will be disabled when "TILE MATRIX" is activated.
POWER ON DELAY	Adjusts the delay time between being in "standby" mode and entering "power on" mode. "POWER ON DELAY" time is selectable from OFF, 2, 4, 6, 8, 10, 20, 30, 40 and 50 sec.
MULTIDISPLAY RESET	Resets the all settings within the MULTI DISPLAY menu back to factory setting.
DISPLAY PROTECTION	
POWER SAVE	Sets how long the monitor waits to go into power save mode after a lost signal. Note: When connecting DVI, video card might not stop sending digital data even if image has disappeared. In this case the monitor does not get to power management mode.
RGB	Selecting "ON", the monitor will go to power management mode when RGB1, 2, 3 sync is lost.
VIDEO	Selecting "ON", the monitor will go to power management mode after about 10 minutes when DVD/HD and VIDEO input signal is lost.
HEAT STATUS	Information of status for COOLING FAN, BRIGHTNESS and TEMPERATURE. COOLING FAN runs when inside temperature is over a guaranteed limit. In this case warning is displayed on the screen.
SCREEN SAVER	Use the SCREEN SAVER function to reduce the risk of Image Persistence.
GAMMA	The display gamma is changed and fixed when "ON" is selected.
COOLING FAN	The built in cooling fan is always on when set "ON".
BRIGHTNESS	The brightness is decreased when "ON" is selected.
MOTION	Image is slightly expanded and moves 4 directions (UP, DOWN, RIGHT, LEFT) periodically (Need setting the time for movement). Movement area is approximately +/- 10 mm from original position; Please locate the important information such as text within 90% area of screen image. See note (1) for this functions. PIP and STILL will be disabled when "MOTION" is active.
SIDE BORDER COLOR	Selects the side black bar color white when 4:3 image displayed, you can select OFF, 50 and 100.
DISPLAY PROTECTION RESET	Resets the all settings within the DISPLAY PROTECTION menu back to factory setting.

ADVANCED OPTION

DVI MODE INPUT RGB1 only	Selects the kind of DVI-D equipment which is connected RGB1. Selects "DVI-PC" when PC or other computer equipment is connected. Selects "DVI-HD" when DVD player, which has DVI-D output, is connected.
SCAN CONVERSION INPUT DVD/HD, VIDEO(S), VIDEO only	Selects IP (Interlace to Progressive) converter function.
PROGRESSIVE	Enables the IP function, to convert interlace signal to progressive. Normally use this.
INTERLACE	Disables the IP function. NOTE: This mode is better suited for motion pictures, but it is in danger of image retention.
COLOR SYSTEM INPUT VIDEO(S), VIDEO only	Selects color system depend on your video format of the input signal. (AUTO/NTSC/PAL/SECAM/4.43NTSC/PAL60) AUTO: Selects color system setting automatically base on input signal.
SCAN MODE INPUT DVD/HD, VIDEO(S), VIDEO only	Changes the display area of the image.
OVER SCAN	Set to display area about 95%
UNDER SCAN	Set to display area about 100%
BLACK LEVEL EXPANSION INPUT VIDEO(S), VIDEO only	Selects a level of black expansion. In case of go under the black cut-off level, please adjust the "Black level" in moderation on OSD menu.
ADVANCED OPTION RESET	Resets the all settings within the ADVANCED OPTION menu back to factory setting.
FACTORY RESET	"Selecting "YES" allows you to reset PICTURE, ADJUST, AUDIO, PIP, OSD, MULTI DISPLAY, DISPLAY PROTECTION and ADVANCED OPTION will be back to factory settings (except LANGUAGE, DATE & TIME and SCHEDULE). Select "YES" and press "SET" button to restore the factory preset data. Press "EXIT" button to cancel and return the previous menu.

NOTE 1: CREATING A SCHEDULE

Using the "SCHEDULE" function allows you to set up to seven different scheduled time intervals when the LCD Monitor will be activated. You can select the time the monitor turns on and turns off, the day of week the monitor is activated, and which input source the monitor will use for each scheduled activation period. A check mark in the box next to the number of the schedule indicates that the selected schedule is in effect.

To select which schedule to set, use the up/down arrows to move the number (1 to 7) of the schedule.

Use the (+) and (-) buttons to move the red bar horizontally within the particular schedule. The "SET" button is used to make a selection.

If you create a schedule but do not want to use a power on time, select "--" in the "ON" time slot.

If you do not want to use a power off time select "--" in the OFF time slot.

If there is no input selected ("--" showing in the input spot) the input from the previous schedule will be used.

The selection of EVERY DAY within a schedule takes priority over other schedules that are set up to operate weekly.

When schedules are overlapping, scheduled Power ON time has priority over scheduled Power OFF time.

Note: If schedules are overlapping then the schedule with the highest number will have priority over the schedule with the lowest number. For example schedule #7 will have priority over schedule #1.

NOTE 2: IMAGE PERSISTENCE

Please be aware that LCD Technology may experience a phenomenon known as Image Persistence. Image Persistence occurs when a residual or "ghost" image of a previous image remains visible on the screen. Unlike CRT monitors, LCD monitors' image persistence is not permanent, but constant images being displayed for a long period of time should be avoided.

To alleviate image persistence, turn off the monitor for as long as the previous image was displayed. For example, if an image was on the monitor for one hour and a residual image remains, the monitor should be turned off for one hour to erase the image.

As with all personal display devices, NEC DISPLAY SOLUTIONS recommends displaying moving images and using a moving screen saver at regular intervals whenever the screen is idle or turning off the monitor when not in use.

Please set "SCREEN SAVER", "DATE & TIME" and "SCHEDULE SETTINGS" functions to further reduce the risk of Image persistence.

For long life use as Public Display**< Image Sticking of LCD Panel >**

When an LCD panel is operated continuously for long hours, a trace of electric charge remains near the electrode inside LCD, and residual or "ghost" image of previous image may be observed. (Image Persistence)

Image Persistence is not permanent, but when fixed image is displayed for long period, ionic impurities inside LCD are accumulated along the displayed image, and may be permanent. (Image Sticking)

< Recommendations >

To prevent Image Sticking, and for longer life usage of LCD, the following are recommended.

1. Fixed image should not be displayed for long period. Change fixed images after short intervals.
2. When not in use, please turn off the monitor by remote control, or use Power Management or use Schedule Functions.
3. Lower environmental temperatures prolong the lifespan of the monitor.
When Protective surface (glass, acrylic) is installed over the LCD surface, the LCD surface is located in an enclosed space, the monitor are stacked, utilize the temperature sensors inside monitor.
To reduce the environmental temperature, use the Cooling Fan, Screen Saver and Low Brightness.
4. Please use "Screen Saver Mode" of monitor.

Controlling the LCD monitor via RS-232C Remote Control

This LCD monitor can be controlled by connecting a personal computer with a RS-232C terminal.

Functions that can be controlled by a personal computer are:

- Power ON or OFF
- Switching between input signals

Connection

LCD Monitor + PC

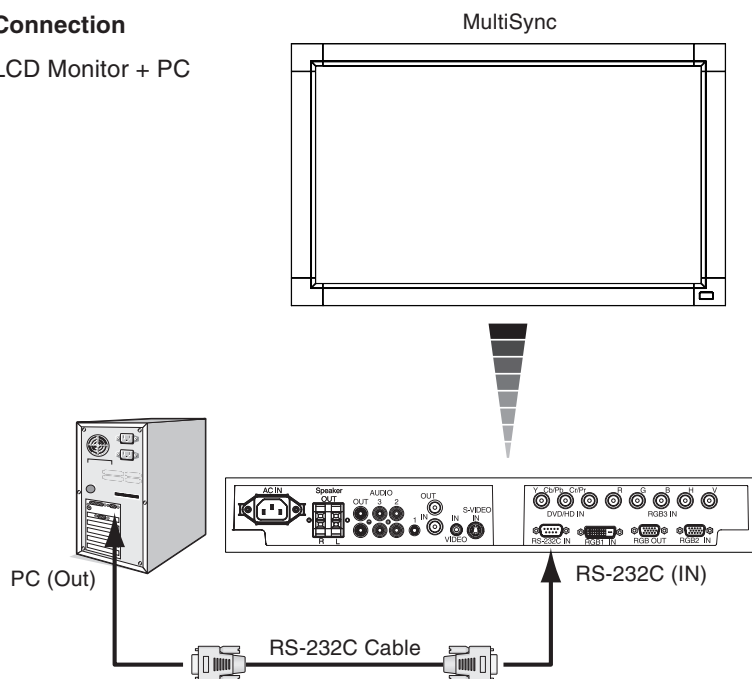

NOTE: If your PC (IBM or IBM compatible) is equipped only with a 25-pin serial port connector, a 25-pin serial port adapter is required. Contact your dealer for details.

* In order to function, the RS-232C OUT terminal can only be connected to another monitor of the same model. Do not connect to other types of equipment.

To control monitor or multiple monitors that are daisy-chained together please use the control command. Instructions for the control command can be found on the CD included with the display. The file is called "External_control.pdf".

1) Interface

PROTOCOL	RS-232C
BAUD RATE	9600 [bps]
DATA LENGTH	8 [bits]
PARITY BIT	NONE
STOP BIT	1 [bit]
FLOW CONTROL	NONE

This LCD monitor uses RXD, TXD and GND lines for RS-232C control.

2) Control command diagram

Please see file "External_Control.pdf" on the CD-ROM.

Features

Reduced Footprint: Provides the ideal solution for environments requiring superior image quality but with size and weight limitations.

Color Control Systems: Allows you to adjust the colors on your screen and customize the color accuracy of your monitor to a variety of standards.

sRGB Color Control: A new optimized color management standard which allows for color matching on computer displays and other peripherals. The sRGB standard, which is based on a calibrated color space, allows for optimal color representation and backward compatibility with other common color standards.

OSD (On-Screen-Display) Controls: Allow you to quickly and easily adjust all elements of your screen image via simple to use on-screen menus.

Plug and Play: The Microsoft® solution with the Windows® operating system facilitates setup and installation by allowing the monitor to send its capabilities (such as screen size and resolutions supported) directly to your computer, automatically optimizing display performance.

IPM (Intelligent Power Manager) System: Provides innovative power-saving methods that allow the monitor to shift to a lower power consumption level when on but not in use, saving two-thirds of your monitor energy costs, reducing emissions and lowering the air conditioning costs of the workplace.

FullScan Capability: Allows you to use the entire screen area in most resolutions, significantly expanding image size.

VESA Standard (FDMLv1) Mounting Interface: Allows users to connect their LCD monitor to any VESA standard (FDMLv1) third party mounting arm or bracket. Allows for the monitor to be mounted on a wall or an arm using any third party compliant device. NEC recommends using mounting interface that comply with TÜV-GS and/or UL1678 standard in North America.

DVI-D: The digital-only subset of DVI ratified by the Digital Display Working Group (DDWG) for digital connections between computers and displays. As a digital-only connector, analog support is not provided for a DVI-D connector. As a DVI-based digital only connection, only a simple adapter is necessary for compatibility between DVI-D and other DVI-based digital connectors such as DFP and P&D. The DVI interface of this display supports HDCP.

TILE MATRIX, TILE COMP: Shows one image over multiple screens with accuracy while compensating for bezel width.

ZOOM: Expands image size for horizontal and vertical direction.

Self-diagnosis: If an internal error should occur, a failure state will be indicated.

Troubleshooting

No picture

- The signal cable should be completely connected to the display card/computer.
- The display card should be completely seated in its slot.
- Front Power Switch and computer power switch should be in the ON position.
- Check to make sure that a supported mode has been selected on the display card or system being used. (Please consult display card or system manual to change graphics mode.)
- Check the monitor and your display card with respect to compatibility and recommended settings.
- Check the signal cable connector for bent or pushed-in pins.

Power Button does not respond

- Unplug the power cord of the monitor from the AC outlet to turn off and reset the monitor.

Image persistence

- Please be aware that LCD Technology may experience a phenomenon known as Image Persistence. Image Persistence occurs when a residual or "ghost" image of a previous image remains visible on the screen. Unlike CRT monitors, LCD monitors' image persistence is not permanent, but constant images being displayed for a long period of time should be avoided. To alleviate image persistence, turn off the monitor for as long as the previous image was displayed. For example, if an image was on the monitor for one hour and a residual image remains, the monitor should be turned off for one hour to erase the image.

NOTE: As with all personal display devices, NEC DISPLAY SOLUTIONS recommends displaying moving images and using a moving screen saver at regular intervals whenever the screen is idle or turning off the monitor when not in use.

Image is unstable, unfocused or swimming is apparent

- Signal cable should be completely attached to the computer.
- Use the OSD Image Adjust controls to focus and adjust display by increasing or decreasing the fine adjustment. When the display mode is changed, the OSD Image Adjust settings may need to be re-adjusted.
- Check the monitor and your display card with respect to compatibility and recommended signal timings.
- If your text is garbled, change the video mode to non-interlace and use 60Hz refresh rate.

Image of component signal is greenish

- Check to see if the DVD/HD input connector is selected.

LED on monitor is not lit

(no green or red color can be seen)

- Power Switch should be in the ON position and power cord should be connected.
- Make certain the computer is not in a power-saving mode (touch the keyboard or mouse).

RED LED on monitor is blinking

- A certain failure might have occurred, please contact your nearest authorized NEC DISPLAY SOLUTIONS service facility.

Display image is not sized properly

- Use the OSD Image Adjust controls to increase or decrease the coarse adjustment.
- Check to make sure that a supported mode has been selected on the display card or system being used. (Please consult display card or system manual to change graphics mode.)

Selected resolution is not displayed properly

- Use OSD Display Mode to enter Information menu and confirm that the appropriate resolution has been selected. If not, select corresponding option.

No Sound

- Check to see if speaker cable is properly connected.
- Check to see if mute is activated.
- Check to see if volume is set at minimum.

Remote Control is not available

- Check the Remote Control's batteries status.
- Check if batteries are inserted correctly.
- Check if the Remote Control is pointing at the monitor's remote sensor.
- Check the Remote Control (IR Control) Mode status.
- The remote control system may not function when direct sunlight or strong illumination strikes the remote control sensor of the LCD monitor, or when there is an object in the path.

"SCHEDULE"/"OFF TIMER" function is not working properly

- The "SCHEDULE" function will be disabled when the "OFF TIMER" is set.
- If the "OFF TIMER" function is enabled and the power to the LCD monitor is turned off when the power supply is interrupted unexpectedly, then the "OFF TIMER" will be reset.

Either light vertical or horizontal stripes may appear, depending on the specific display pattern. This is no product fault or degradation.

Specifications - LCD3215

Product Specifications

LCD Module		Pixel Pitch:	32"/80.0 cm diagonal
		Resolution:	0.511 mm
		Color:	1366 x 768 dots
		Brightness:	Over 16 million colors (depending on video card used)
		Contrast Ratio:	500 cd/m ² (Typ.)
		Viewing Angle:	800:1
		Design View Distance:	89° (typ) @ CR>10
			875 mm
Frequency		Horizontal:	15.625/15.734 kHz, 31.5 kHz - 91.1 kHz
		Vertical:	58.0 - 85.0 Hz
Pixel Clock			13.5 MHz - 165.0 MHz
Viewable Size			697.7 x 372.3 mm
Input Signal			
RGB1	DVI-D 24pin	Digital RGB	DVI (HDCP) VGA60, SVGA60, XGA60, WXGA60, SXGA60*, UXGA60*
RGB2	15pin Mini D-sub	Analog RGB	0.7 Vp-p/75 ohm VGA60, SVGA60, XGA60, WXGA60, SXGA60*, UXGA60*
		Sync	Separate: TTL level (Pos./Neg.)
RGB3	BNC (R,G,B,H,V)	Analog RGB	0.7 Vp-p/75 ohm VGA60, SVGA60, XGA60, WXGA60, SXGA60*, UXGA60*
		Sync	Separate: TTL level (Pos./Neg.)
DVD/HD	BCN (Y, Cb/Pb, Cr/Pr)	Component	Y : 1.0 Vp-p/75ohm, Cb/Cr (Pb/Pr) : 0.7 Vp-p/75 ohm HDTV/DVD: 720p@50Hz/60Hz, 576p@50Hz, 480p@60Hz, 576i@50Hz, 480i@60Hz
VIDEO(S)	Mini DIN 4 pin	S-VIDEO	Y: 1.0 Vp-p/75 ohm C: 0.286 Vp-p/75 ohm (NTSC), 0.3 Vp-p/75 ohm (PAL/SECAM) NTSC/PAL/SECAM/4.43NTSC/PAL60
VIDEO	BNC RCA	Composite	1.0 Vp-p/75 ohm NTSC/PAL/SECAM/4.43NTSC/PAL60
Output Signal			
RGB	15pin Mini D-sub	Analog RGB	0.7 Vp-p with 75 ohm terminated Separate HV sync: TTL level (Posi / Nega)
VIDEO	BNC	Composite	1.0 Vp-p with 75 ohm terminated
AUDIO			
AUDIO Input	RCA (L/R) X2 STEREO Mini Jack	Analog Audio	Stereo L/R 0.5 Vrms
AUDIO Output	STEREO Mini Jack	Analog Audio	Stereo L/R 0.5 Vrms
Speaker Output			External Speaker Jack 7 W + 7 W (8 ohm)
Control		RS-232C In:	9 Pin D-sub
Power Supply			1.4 - 0.6 A @ 100-240VAC, 50/60Hz
Operational Environment		Temperature:	5 - 40°C (landscape), 5 - 35°C (portrait)
		Humidity:	20 - 80% (without condensation)
		Altitude:	0 - 3000 m
Storage Environment		Temperature:	-20 - 60°C
		Humidity:	10 - 90% (without condensation)/ 90% - 3.5% x (Temp - 40°C) regarding over 40°C
Dimension		Net:	789 (W) x 476.3 (H) x 133 (D) mm (without stand)
		Gross:	930 (W) x 610 (H) x 283 (D) mm
Weight (Without stand)		Net:	16.2 Kg
		Gross:	23.5 Kg
VESA compatible arm mounting interface			200 mm x 200 mm (4 Holes)
Complied Regulatory and Guidelines			UL60950-1/CSA C22.2 No.60950-1/ TUV-GS/EN60950-1 FCC- B/DOC-B/EN55022-B/EN55024/EN61000-3-2/EN61000-3-3/CE/GOST-R
Power Management			VESA DPM
Plug & Play			VESA DDC2B, DDC/CI
Accessories			Setup manual, Power Cord, Video Signal Cable, Remote Control, AAA Battery x 2, Clamp x 2, Screw for Main switch cover x 2, Screw for Clamp x 2, CD-ROM, Main switch cover

NOTE: Technical specifications are subject to change without notice.

*1: Compressed image

Specifications - LCD4215

Product Specifications

LCD Module		Pixel Pitch:	42"/106.6 cm diagonal
		Resolution:	0.681 mm
		Color:	1366 x 768 dots
		Brightness:	Over 16 million colors (depending on video card used)
		Contrast Ratio:	500 cd/m ² (Typ.)
		Viewing Angle:	800:1
		Design View Distance:	89° (typ) @ CR>10
			1100 mm
Frequency		Horizontal:	15.625/15.734 kHz, 31.5 kHz - 91.1 kHz
		Vertical:	58.0 - 85.0 Hz
Pixel Clock			25.0 MHz - 162.0 MHz
Viewable Size			930.25 x 523.01 mm
Input Signal			
RGB1	DVI-D 24pin	Digital RGB	DVI (HDCP) VGA60, SVGA60, XGA60, WXGA60, SXGA60*, UXGA60*
RGB2	15pin Mini D-sub	Analog RGB	0.7 Vp-p/75 ohm VGA60, SVGA60, XGA60, WXGA60, SXGA60*, UXGA60*
		Sync	Separate: TTL level (Pos./Neg.)
RGB3	BNC (R,G,B,H,V)	Analog RGB	0.7 Vp-p/75 ohm VGA60, SVGA60, XGA60, WXGA60, SXGA60*, UXGA60*
		Sync	Separate: TTL level (Pos./Neg.)
DVD/HD	BNC (Y, Cb/Pb, Cr/Pr)	Component	Y : 1.0 Vp-p/75ohm, Cb/Cr (Pb/Pr) : 0.7 Vp-p/75 ohm HDTV/DVD: 720p@50Hz/60Hz, 576p@50Hz, 480p@60Hz, 576i@50Hz, 480i@60Hz
VIDEO(S)	Mini DIN 4 pin	S-VIDEO	Y: 1.0 Vp-p/75 ohm C: 0.286 Vp-p/75 ohm (NTSC), 0.3 Vp-p/75 ohm (PAL/SECAM) NTSC/PAL/SECAM/4.43NTSC/PAL60
VIDEO	BNC RCA	Composite	1.0 Vp-p/75 ohm NTSC/PAL/SECAM/4.43NTSC/PAL60
Output Signal			
RGB	15pin Mini D-sub	Analog RGB	0.7 Vp-p with 75 ohm terminated Separate HV sync: TTL level (Posi / Nega)
VIDEO	BNC	Composite	1.0 Vp-p with 75 ohm terminated
AUDIO			
AUDIO Input	RCA (L/R) X2 STEREO Mini Jack	Analog Audio	Stereo L/R 0.5 Vrms
AUDIO Output	STEREO Mini Jack	Analog Audio	Stereo L/R 0.5 Vrms
Speaker Output			External Speaker Jack 7 W + 7 W (8 ohm)
Control		RS-232C In:	9 Pin D-sub
Power Supply			3.4 - 1.35 A @ 100-240VAC, 50/60Hz
Operational Environment		Temperature:	5 - 40°C (landscape), 5 - 35°C (portrait)
		Humidity:	20 - 80% (without condensation)
		Altitude:	0 - 3000 m
Storage Environment		Temperature:	-20 - 60°C
		Humidity:	10 - 90% (without condensation)/ 90% - 3.5% x (Temp - 40°C) regarding over 40°C
Dimension		Net:	1022.9 (W) x 613.5 (H) x 133 (D) mm (without stand)
		Gross:	1175 (W) x 774 (H) x 283 (D) mm
Weight (Without stand)		Net:	20.5 Kg
		Gross:	47.1 Kg
VESA compatible arm mounting interface			200 mm x 200 mm (4 Holes)
Complied Regulatory and Guidelines			UL60950-1/CSA C22.2 No.60950-1/ TUV-GS/EN60950-1 FCC-B/DOC-B/EN55022-B/EN55024/EN61000-3-2/EN61000-3-3/CE/GOST-R
Power Management			VESA DPM
Plug & Play			VESA DDC2B, DDC/CI
Accessories			Setup manual, Power Cord, Video Signal Cable, Remote Control, AAA Battery x 2, Clamp x 2, Screw for Main switch cover x 2, Screw for Clamp x 2, CD-ROM, Thumbscrew for stand x 2, Main switch cover

NOTE: Technical specifications are subject to change without notice.

*1: Compressed image

Pin Assignment

1) Analog RGB input (MiniDsub15p): VGA

Pin No	Name
1	Video Signal Red
2	Video Signal Green
3	Video Signal Blue
4	GND
5	DDC-GND
6	Red-GND
7	Green-GND
8	Blue-GND
9	+5V (DDC)
10	SYNC-GND
11	GND
12	DDC-SDA
13	H-SYNC
14	V-SYNC
15	DDC-SCL

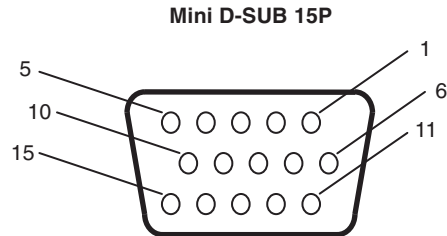

2) VIDEO(S) input: VIDEO

Pin No	Name
1	GND
2	GND
3	Y (Luminance)
4	C (Chroma)

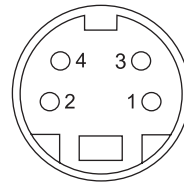

3) Digital RGB input (DVI-D): DVI

Pin - Assignment of DVI connector:					
1	TX2-	9	TX1-	17	TX0-
2	TX2+	10	TX1+	18	TX0+
3	Shield (TX2 / TX4)	11	Shield (TX1 / TX3)	19	Shield (TX0 / TX5)
4	NC	12	NC	20	NC
5	NC	13	NC	21	NC
6	DDC-Serial Clock	14	+5V power	22	Shield (TXC)
7	DDC-Serial Data	15	Ground	23	TXC+
8	NC	16	Hot plug detect	24	TXC-

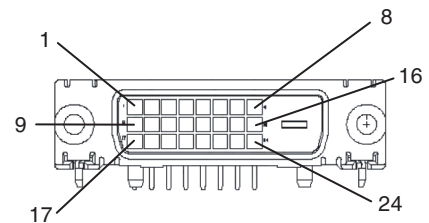

4) RS-232C input

Pin No	Name
1	connected to 7&8
2	RXD
3	TXD
4	connected to 6
5	GND
6	connected to 4
7	connected to 1&8
8	connected to 1&7
9	NC

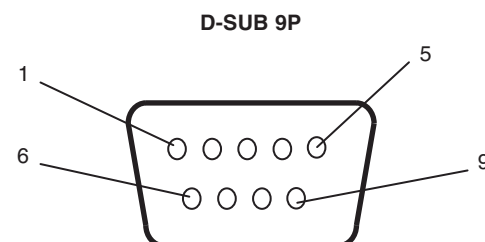

This LCD monitor uses RXD, TXD and GND lines for RS-232C control.

Manufacturer's Recycling and Energy Information

NEC DISPLAY SOLUTIONS is strongly committed to environmental protection and sees recycling as one of the company's top priorities in trying to minimize the burden placed on the environment. We are engaged in developing environmentally-friendly products, and always strive to help define and comply with the latest independent standards from agencies such as ISO (International Organisation for Standardization) and TCO (Swedish Trades Union).

Disposing of your old NEC product

The aim of recycling is to gain an environmental benefit by means of re-use, upgrading, reconditioning or reclamation of material. Dedicated recycling sites ensure that environmentally harmful components are properly handled and securely disposed. To ensure the best recycling of our products, **NEC DISPLAY SOLUTIONS offers a variety of recycling procedures** and gives advice on how to handle the product in an environmentally sensitive way, once it has reached the end of its life.

All required information concerning the disposal of the product and country-specific information on recycling facilities can be found on our following websites:

<http://www.nec-display-solutions.com/greencompany/> (in Europe),

<http://www.nec-display.com> (in Japan) or

<http://www.necdisplay.com> (in USA).

Energy Saving

This monitor features an advanced energy saving capability. When a VESA Display Power Management Signalling (DPMS) Standard signal is sent to the monitor, the Energy Saving mode is activated. The monitor enters a single Energy Saving mode.

Mode	Power consumption	LED color
Normal Operation	Approx. 140W (LCD3215) Approx. 210W (LCD4215)	Green
Energy Saving Mode	Less than 5W	Red and Green

WEEE Mark (European Directive 2002/96/EC)



Within the European Union

EU-wide legislation, as implemented in each Member State, requires that waste electrical and electronic products carrying the mark (left) must be disposed of separately from normal household waste. This includes monitors and electrical accessories, such as signal cables or power cords. When you need to dispose of your NEC display products, please follow the guidance of your local authority, or ask the shop where you purchased the product, or if applicable, follow any agreements made between yourself and NEC.

The mark on electrical and electronic products only applies to the current European Union Member States.

Outside the European Union

If you wish to dispose of used electrical and electronic products outside the European Union, please contact your local authority so as to comply with the correct disposal method.

Free Manuals Download Website

<http://myh66.com>

<http://usermanuals.us>

<http://www.somanuals.com>

<http://www.4manuals.cc>

<http://www.manual-lib.com>

<http://www.404manual.com>

<http://www.luxmanual.com>

<http://aubethermostatmanual.com>

Golf course search by state

<http://golfingnear.com>

Email search by domain

<http://emailbydomain.com>

Auto manuals search

<http://auto.somanuals.com>

TV manuals search

<http://tv.somanuals.com>