

NADY[®] AUDIO

OWNER'S MANUAL



SPM SERIES

SPM 6600 — 6 Channel Stereo Powered Mixer w/Internal DSP Effects

SPM 8600 — 8 Channel Stereo Powered Mixer w/Internal DSP Effects

SPM SERIES

Stereo Powered Mixer With Internal DSP Effects



Congratulations on your choice of stereo powered mixers — you have purchased one of the finest stereo powered mixing units on the market today. This unit was developed using the expertise of professional sound engineers and working musicians. You will find that your new NADY AUDIO SPM 6600/8600 has superior performance and greater flexibility than any other stereo powered mixer in its price range. Please read this manual carefully to get the most out of your new unit.

Thanks for selecting NADY AUDIO as your choice in stereo powered mixing unit.

Date of Purchase _____

Dealer's Name _____

City _____

State _____ Zip _____

Model # _____

Serial # _____

TABLE OF CONTENTS

WARNING	3
FEATURES	4
INSTALLATION	5
1. Inspection	5
2. Setup and Operation	5
CONTROLS AND CONNECTIONS	6
1. Mono Input Section	6
2. 7-Band Stereo Graphic Equalizer Section	7
3. Digital Effect Section	8
4. Master Control Section	9
5. Input / Output Jacks	10
6. Rear Panel	10
7. Speakers Connection Examples	11
CONNECTIONS	12
SPECIFICATIONS	13
BLOCK DIAGRAM	14

WARNING

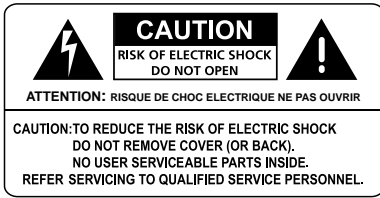

An equilateral triangle enclosing a lightning flash/arrowhead symbol is intended to alert the user to the presence of uninsulated "dangerous voltage" within the product's enclosure which may be of sufficient magnitude to constitute a risk of electric shock.



An equilateral triangle enclosing an exclamation point is intended to alert the user to the presence of important operating and service instructions in the literature enclosed with this unit.

IMPORTANT SAFETY INSTRUCTIONS

When using this electronic device, basic precautions should always be taken, including the following:

1. Read all instructions before using the product.
2. Do not use this product near water (e.g., near a bathtub, washbowl, kitchen sink, in a wet basement, or near a swimming pool, etc.).
3. This product should be used only with a cart or stand that will keep it level and stable and prevent wobbling.
4. This product, in combination with headphones or speakers, may be capable of producing sound levels that could cause permanent hearing loss. Do not operate for a long period of time at a high volume level or at a level that is uncomfortable. If you experience any hearing loss or ringing in the ears, you should consult an audiologist.
5. The product should be positioned so that proper ventilation is maintained.
6. The product should be located away from heat sources such as radiators, heat vents, or other devices (including amplifiers) that produce heat.
7. The product should be connected to a power supply only of the type described in the operating instructions or as marked on the product. Replace the fuse only with one of the specified type, size, and correct rating.
8. The power supply cord should: (1) be undamaged, (2) never share an outlet or extension cord with other devices so that the outlet's or extension cord's power rating is exceeded, and (3) never be left plugged into the outlet when not being used for a long period of time.
9. Care should be taken so that objects do not fall into, and liquids are not spilled through, the enclosure's openings.
10. The product should be serviced by qualified service personnel if:
 - A. The power supply cord or the plug has been damaged.
 - B. Objects have fallen into, or liquid has been spilled onto the product.
 - C. The product has been exposed to rain.
 - D. The product does not appear to operate normally or exhibits a marked change in performance.
 - E. The product has been dropped, or the enclosure damaged.
11. Do not attempt to service the product beyond what is described in the user maintenance instructions. All other servicing should be referred to qualified service personnel.

FEATURES



Offering top-of-the-line performance, features, ease of operating flexibility, and rugged construction for long-life reliability, the SPM Series is the best choices available in stereo powered mixers.

- **SPM 6600** — 6 balanced or unbalanced XLR mic inputs and 6 balanced or unbalanced 1/4" TRS mono line inputs
- **SPM 8600** — 8 balanced or unbalanced XLR mic inputs and 8 balanced or unbalanced 1/4" TRS mono line inputs
- Dual 300 watt X2 (@4 Ohms) amplifiers can be switched to power stereo, or mains and monitor speakers, or deliver 600 watts @8 Ohms/750 watts @4 Ohms bridged mono. Advanced design features include temperature limiting, short circuit current limiting, speaker DC protection circuits, L/R Protect LED warning indicators for utmost safety and reliability and power ON/OFF anti-thump circuit for quietest operation
- Built-in DSP (Digital Sound Processor) for ECHO (REVERB) with 16 natural sounding selectable preset level and echo intervals and separate DSP Send and Master DSP Mix control, and numeric LED display
- Each channel includes stereo pan, level, and DSP/Aux controls, 3 band EQ and input signal 20dB pad switches
- 7 band stereo master graphics EQ's
- Selectable global 48V phantom power on XLR mic inputs
- 5 LED stereo level display with switchable level meter (L-R/Main-Monitor)
- Left, Right and Main Master, and Monitor Out level controls
- Master section also includes stereo tape input and stereo recording output RCA jacks with Tape In level control, stereo Master Mix and mono Monitor Mix 1/4" outputs, Aux Send and stereo Aux 1,2 Returns with master Aux Send and Aux 1, 2 Return controls, and master DSP/MIX control
- All EQ and PAN controls have center detents
- Rugged road carrying case with reinforced corners and carrying handles for long life and easy portability
- Dimensions & Weights:

SPM 6600: 11.8" x 18.8" x 12" (30.5 cm x 47.7 cm x 30 cm), 43 lbs. (19.5 Kg)

SPM 8600: 11.8" x 18.8" x 12" (30.5 cm x 47.7 cm x 30 cm), 44 lbs. (19.9 Kg)

INSTALLATION

To ensure years of enjoyment from your NADY AUDIO SPM 6600/8600 powered mixer, please read and understand this manual thoroughly before using the unit.

1. INSPECTION

Your NADY AUDIO SPM 6600/8600 was carefully packed at the factory in packaging designed to protect the units in shipment. Before installing and using your unit, carefully examine the packaging and all contents for any signs of physical damage that may have occurred in transit.

[Please note: Nady Systems is not responsible for shipping damage. If your unit is damaged, do not return to Nady, but notify your dealer and the shipping company (if shipped to you) immediately to make a claim. Such claims must be made by the consignee in a timely manner.]

2. SETUP AND OPERATION

Parts of the unit can become very warm during use. This is normal during operation. Care should be taken to ensure that there is enough space around the unit for cooling. Also, do not place the SPM 6600/8600 on high temperature devices such as power amplifiers, etc., or the unit may overheat in operation.

Although the unit's chassis is shielded against radio frequency (RF) and electromagnetic interference (EMI), extremely high fields of RF and EMI should be avoided.

Please make sure that the power unit supplied is marked for the correct voltage in your area (120VAC/60 Hz or 230VAC/50 Hz). Power requirements for electrical equipment differ from area to area. In new installations and portable sound systems, or any situation in which the AC power is in question, it is wise to confirm the voltage and use the appropriate power supply unit before connecting it to power sources.

Europe (except UK): 230V, 50Hz
UK and Australia: 240V, 50Hz
USA and Canada: 120V, 60 Hz
For other areas, please check with local authorities.

When ready to operate, plug the AC cord into the power source. Make sure that the unit is turned off before connecting to the AC power source to avoid possible loud transients which can damage your speakers or your ears. Set the noted controls to the positions indicated below to further minimize the chance of undesired noise when first powering up your SPM 6600/8600 :

LEFT/RIGHT & MAIN MONITOR CONTROLS (12,24,26) SET TO MINIMUM

HI, MID & LOW EQ'S (5) AND PAN/BALANCE CONTROLS (1) TURNED TO THE CENTER DETENT POSITION

DSP EFFECT ON/OFF SWITCH (14)..... SET TO OFF

Power up the unit as noted on page 10 and 11.

CONTROLS AND CONNECTIONS

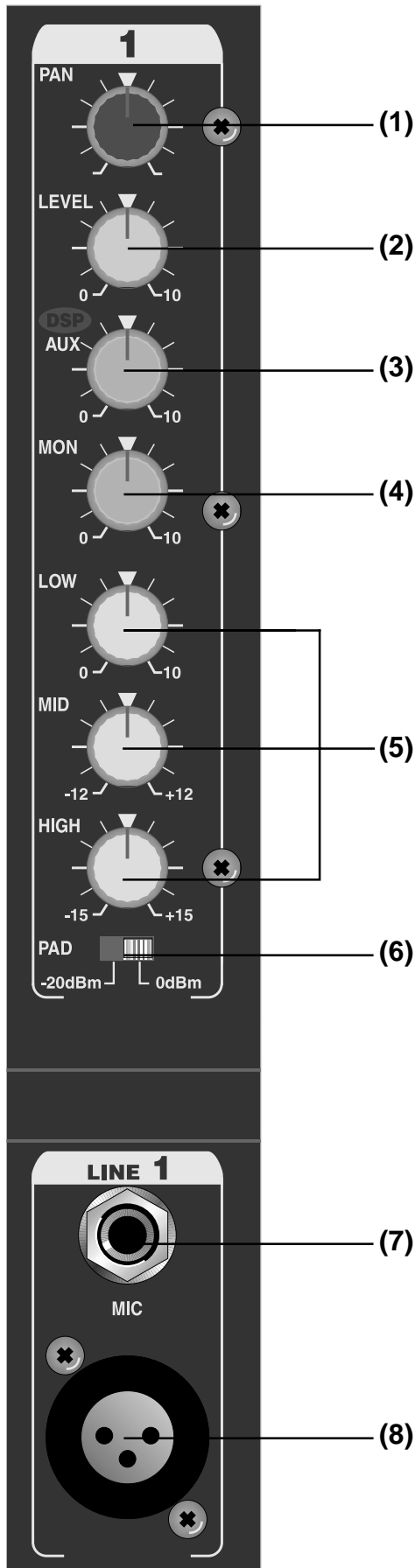

1. MONO INPUT SECTION

(1) PAN CONTROL

The Channel Pan positions the output of the channel in the stereo field of the Master Mix. Its constant-power design ensures there are no level discrepancies whether a signal is hard-panned L or R, center-stage, or somewhere in-between.

(2) LEVEL

This adjusts the output level for each channel.

(3) AUX/DSP CONTROL

The **AUX/DSP** controls are mono and post-EQ and post-fader and the signal level sent to the **AUX/DSP** bus will be affected by the channel fader setting. The **AUX** configuration is ideal for almost all monitoring purpose: for example, for a separate stage monitor mix in live performances or a studio room monitor in recording applications, such as for a headphone cue system. The **AUX/DSP** controls the level sent by each channel to the internal DSP (Digital Sound Processor).

(4) MON (MONITOR)

The **MON** controls the amount of signal to the **MONITOR** bus and **MONITOR OUTPUT (24)** control.

*(Note: The signal is sent to the **MONITOR** bus from a location before the **LEVEL (2)** control of each channel. This means that it will not be affected by the setting of the **LEVEL (2)** control.)*

(5) EQUALIZER CONTROLS

All input channels are fitted with a three-band EQ. All three bands have up to 15 dB of cut and boost, with a center detent for "off". The frequency response is flat when all three EQ knobs are in the center detent position. The upper and lower shelving controls have their frequencies fixed at 12 kHz and 80 Hz respectively. The midrange control has a peaking response at 2.5kHz (Q fixed at 1 octave). The channel EQ is a valuable feature of the mixer as it allows the user to control the tonal characteristics of each channel separately. For example, boosting the **LOW** can fatten the sound and add punch to the bass or drums; the **MID** control can be used to define the midrange or bring out the vocals; and adjusting the **HIGH** control can provide a crisp sounding high end. Another very important, yet often overlooked technique is to use the EQ to subtract from the mix. Cutting the **HIGH** control can reduce unwanted hiss during multi-track recording, while attenuating the **MID** or **LOW** can eliminate feedback in a live performance or clear up a muddy sounding mix. Cutting away the top and bottom, then pushing up the Gain is equivalent to mid range boost!

CONTROLS AND CONNECTIONS

[Note: Always reset a channel's input Gain (or external devices' output level) after altering the amount of mixer equalization cut or boost applied.]

The key to successful equalization is to avoid excess. Too much equalization on the input channels will result in a mix that is smeared together with nothing specifically defined. During rehearsals, experiment with the equalizer controls on various instruments, vocals and combinations of these mixed together to become familiar with various equalizer settings.

(6) PAD

This switch attenuates the input signal by -20dB. When connecting a line level device to channels, or if the mic input is distorted, set this switch to the position of -20dB.

(7) LINE INPUT

The Line input is designed to accept balanced or unbalanced line-level signals such as those from keyboards, drum machines, or samplers. There is enough gain available on the line input to accept even lower level signals, such as those from an unbalanced microphone or guitar output. If a balanced signal is to be connected to the line input, then a 1/4" TRS (stereo) phone plug should be wired for: Tip = positive (+), Ring = negative (-), Sleeve = ground.

(Note: Only either the Mic or the Line input of a given channel should be connected at one time.)

(8) MIC INPUT

The Mic input is an electronically balanced XLR type designed to accept signals from any balanced or unbalanced low impedance (Low Z) microphone. The XLR jack is configured for: Pin1 = ground, Pin2 = positive (+), Pin3 = negative (-).

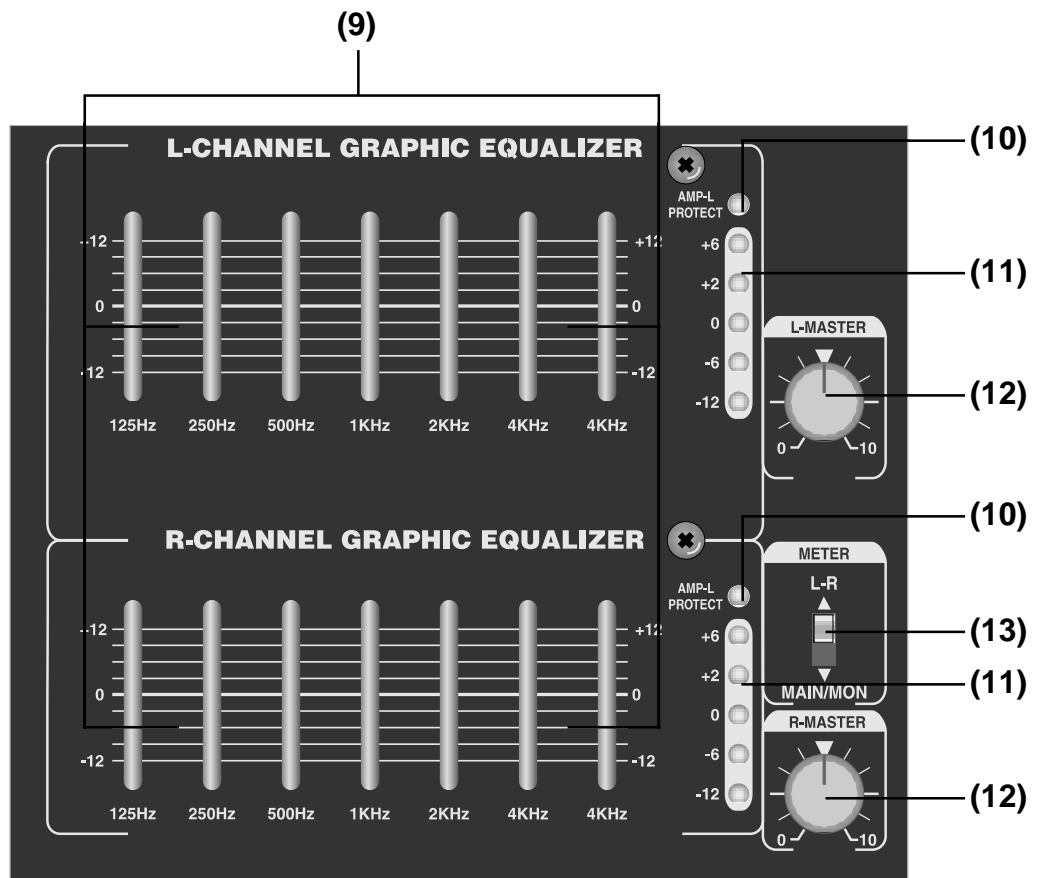

2. 7-BAND STEREO GRAPHIC EQUALIZER SECTION

(9) L AND R CHANNEL GRAPHIC EQUALIZER

The 7-band channel graphic equalizer allows you to adjust the frequency response of the L and R Channel bus signal, providing a maximum of ± 12 dB of cut and boost for each frequency band from the flat position. When in BRIDGE MODE, the L-Channel EQ controls the output.

(10) L AND R AMP PROTECT LED

These LEDs will indicate the operation of the protection circuits in the POWER AMP (L and R) section. Shut off unit if this lights during use, and check output connections. Do not operate the unit until this LED is off. If the condition persists, have the unit serviced by qualified personnel.

(Note: This LED will flash when the unit is powered on. This is normal.)

CONTROLS AND CONNECTIONS

(11) L AND R LED VU METER

This will display the relative output level of the Left and Right Main **PWR AMPS MODE (25)** in STEREO and BRIDGE MODE. It will also display the relative output level of the **PWR AMPS MODE (25)** in the MAIN/MONITOR switch position .

(12) L AND R MASTER

These controls the final level of the Left and Right Master Channel bus.

- They set the amount of the MASTER LEFT/RIGHT signal sent to the internal left/right power amplifier or the external power amplifier connected to the **MIX OUT (36)** jacks.
- The LEFT MASTER sets the level of the signal sent to the internal power amplifiers when the **PWR AMP MODE (25)** selector is in the BRIDGE position.

(13) METER MODE

The **METER MODE** switch displays L/R BUS signals to power amps when in the L/R position.

When in the MAIN/MONITOR position, the Left VU Meter displays Main bus signal and the Right VU Meter displays Monitor bus signals to the power amps.

When in BRIDGE MODE, switch the **METER MODE (13)** to L/R position and Left VU Meter displays signal to the power amp.

3. DIGITAL EFFECT SECTION

14) DSP ON/OFF SWITCH

The built-in DSP (Digital Sound Processor) offers 16 different preset level and echo intervals. To use, press this switch to ON.

15) PEAK LED

This indicator allows you to monitor the level of the signals which are sent to the built-in 16 bit digital effect. To avoid distortion, adjust the channel **DSP/AUX (3)** control so that the indicator lights only occasionally on peak levels.

16) REPEAT

This control adjusts the number of repeats (returns) of the DSP system. Adjust for desired sound effect.

17) EFFECTS DISPLAY

Will indicate which of the 16 effect presets has been selected.

18) ECHO EFFECT SELECT UP/DOWN BUTTONS

Press either button to scroll in either direction through the 16 presets.

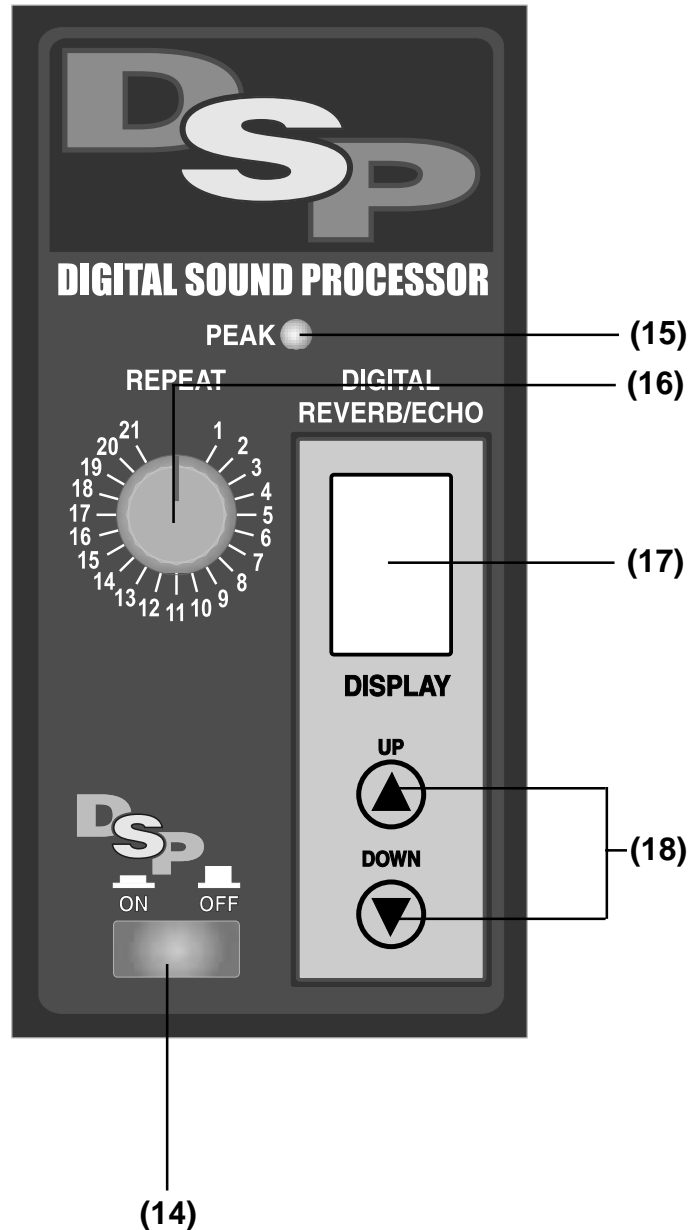

CONTROLS AND CONNECTIONS

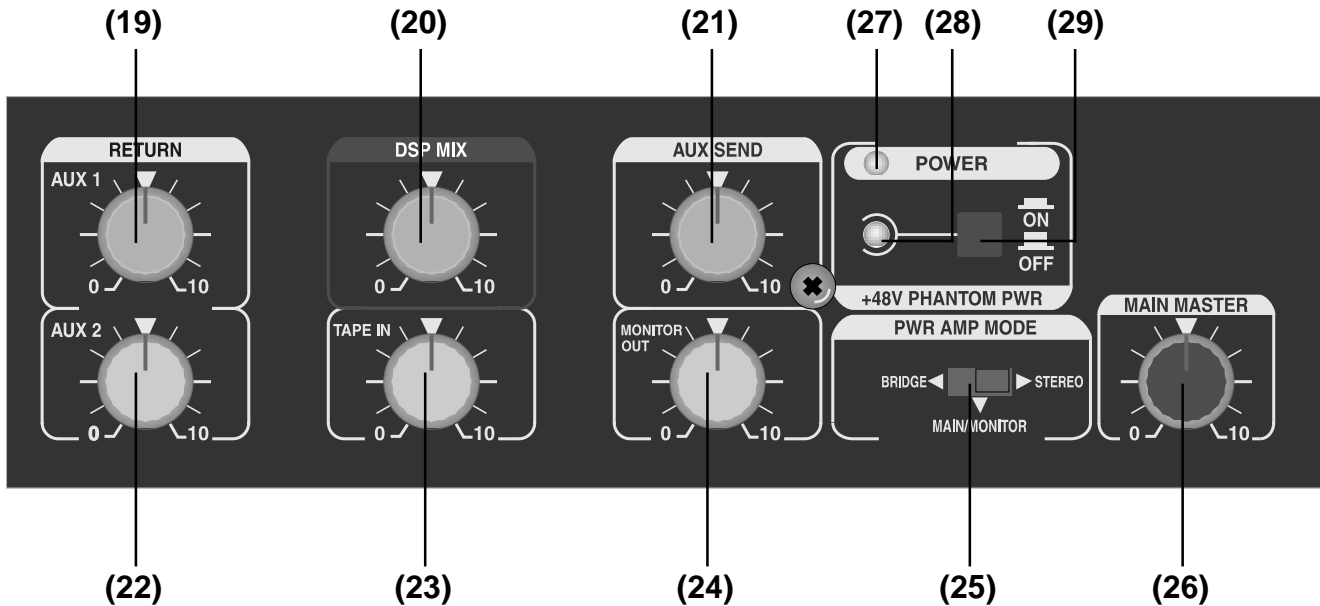

4. MASTER CONTROL SECTION

(19 & 22) AUX 1 AND 2 RETURNS CONTROLS

These are input controls that adjust the levels of the signal at the AUX input jacks.

20) DSP/MIX

This is a master control that adjust the return of the DSP signals that effect all channels.

21) AUX SEND

This is a master control that adjusts the output signal level at the **AUX SEND (30)** jack.

23) TAPE IN

This adjusts the amount of signal that is sent from the external tape player connected to **TAPE IN L,R (34,35)** jacks.

24) MONITOR OUT

This adjusts the final level of the MONITOR bus. It affects both the MONITOR output jack and output of the **RIGHT/MONITOR SPEAKER OUTPUT (37)** jacks when **PWR AMP MODE (25)** switch is in MAIN/MONITOR position.

25) POWER AMP MODE

The **PWR AMP MODE** switch allows you to select the signal that will be output from the built-in dual channel amplifier: STEREO, BRIDGE or MAIN/MONITOR MODE.

26) MAIN MASTER

This adjusts the final level of the MAIN bus signal that is sent to the **LEFT/MAIN SPEAKER OUTPUT (37)**, when **PWR AMP MODE (25)** switch is in the MAIN/MONITOR position.

27) POWER LED

The red LED will illuminate when the unit is switched on.

28) PHANTOM POWER LED

The LED will illuminate when the **PHANTOM POWER (29)** switch is depressed to ON.

29) PHANTOM POWER ON/OFF SWITCH

When this switch is depressed, +48V of phantom power will be supplied to the mic channels.

(Note: When turning on the PHANTOM POWER (29) switch, turn channel level to minimum.)

CONTROLS AND CONNECTIONS

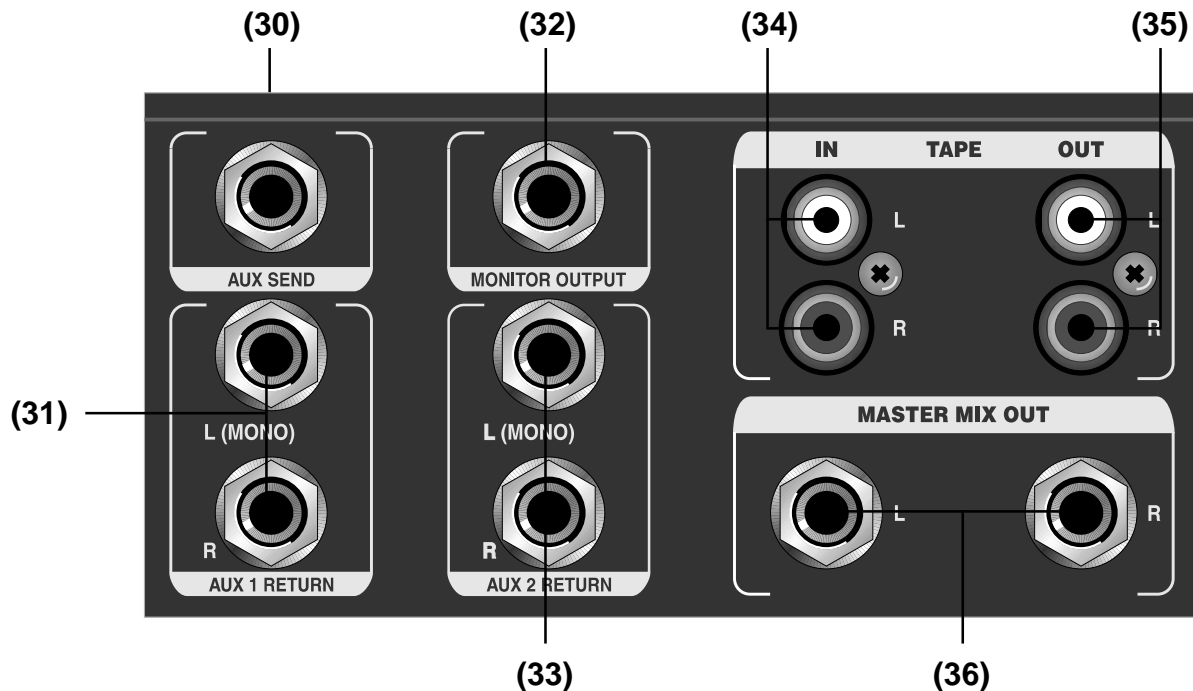

5. INPUT / OUTPUT JACKS

30) AUX SEND JACK

The **AUX SEND JACK** provides a mono mixed signal from the input channels to an external effects unit or other devices.

The signal is adjusted by the **AUX/DSP (3)** controls of each channel and by the **AUX SEND (21)** control.

31 & 33) AUX 1 AND 2 RETURN JACKS

These jacks will accept the signal from an external effects unit and other line level devices. These are adjusted by **AUX 1 and 2 LEVELS (19,20)** controls.

32) MONITOR OUT JACK

This jack provides a nominal line level signal for stage monitoring purpose. Its level is adjusted by the **MONITOR OUT (24)** control.

34) TAPE IN L, R JACKS

These jacks will accept the signal from an external device with a stereo output, such as a cassette recorder. The level is adjusted by the **TAPE IN (23)** control.

35) TAPE OUT L, R JACKS

These jacks can be used to connect the LEFT/RIGHT output signals to external recording devices.

36) MASTER MIX OUT JACKS

Use these jacks to connect to an external power amplifier if extra output power for a larger P.A. system is required.

6. REAR PANEL

37) SPEAKER OUTPUT JACKS

- **RIGHT/MONITOR** — Is use in STEREO MODE for right output or MAIN/MONITOR MODE for monitor output
- **LEFT/MAIN** — Is used in STEREO MODE for left output or in MAIN/MONITOR MODE for main output
- **BRIDGED MODE** — Is used only in BRIDGED MODE.

(Note: RIGHT/MONITOR (37) output jacks are connected in parallel internally. LEFT/MAIN (37) output jacks are connected in parallel internally)

(Caution: When using RIGHT/MONITOR (37) and LEFT/MAIN (37) output jacks do not plug anything in BRIDGED output jack. When using BRIDGE MODE do not plug anything into RIGHT/MONITOR (37) or LEFT/MAIN (37) jacks)

38) POWER CONNECTOR

The IEC jack is used to connect the power cord to the AC Power Source.

(Caution: Do not remove the center grounding pin.)

39) FUSE COMPARTMENT

Replace with only the same type fuse (see page 13). If it blows continuously, do not use the unit until it has been serviced by qualified personnel.

CONTROLS AND CONNECTIONS

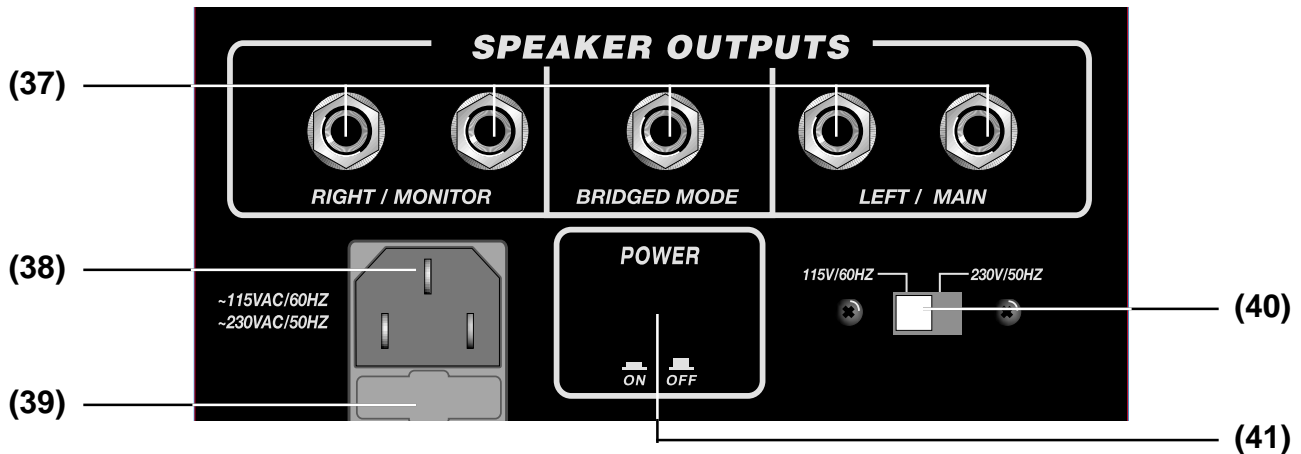

40) AC VOLTAGE SELECTOR SWITCH

Before plugging in the power cord, check to see that the unit is set for the proper voltage for your area: ~115V (60Hz) or ~230V (50Hz)

(50Hz)

41) POWER ON/OFF SWITCH

To turn the unit ON press the button in, to turn the unit OFF repress the button out.

7. SPEAKER CONNECTION EXAMPLES

The following speaker connections can be used for **STEREO** or **MONITOR MAIN** operations. Both **RIGHT/MONITOR** jacks are paralleled together and **LEFT/MAIN** jacks are paralleled together.

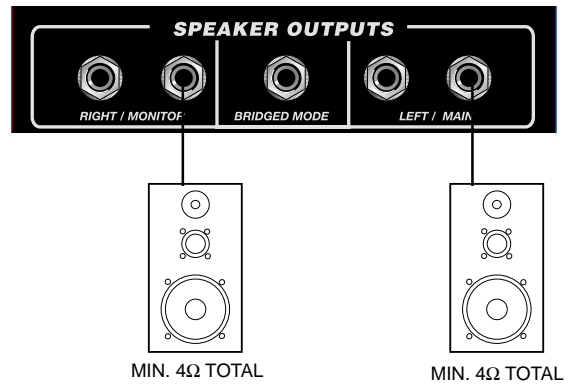
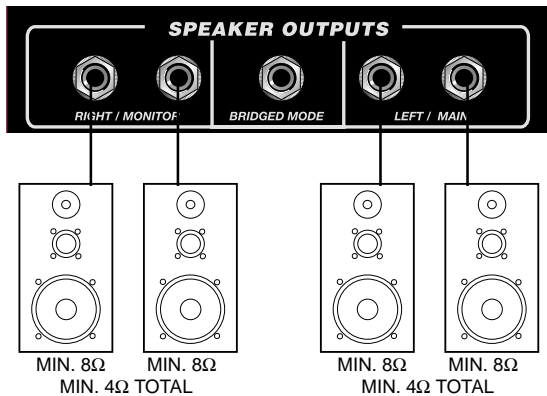

BRIDGE CONNECTION

Connecting a single speaker to the BRIDGE jack. (Unit should be set to **BRIDGE MODE**).

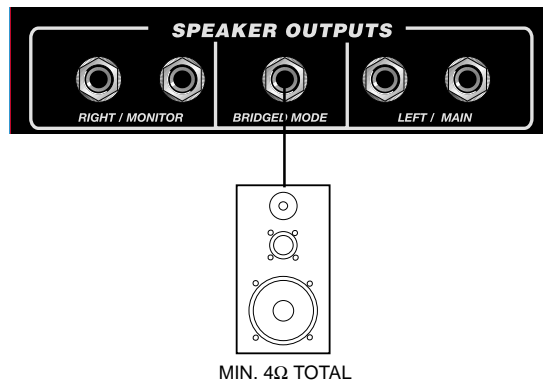

CONNECTIONS

This NADY AUDIO mixer uses 4 different types of audio connectors for the various input/output connections: (1) XLR balanced; (2) 1/4" TRS phone jacks for balanced, unbalanced, stereo, or in/out inserts; (3) 1/4" TS unbalanced; (4) RCA pin unbalanced

Figures

1. Balanced XLR input/output connections
2. Stereo headphone connection with 1/4" TRS plug
3. 1/4" mono (TRS) plug used as unbalanced input/output
4. 1/4" stereo (TRS) plug used as balanced input/output
5. 1/4" TRS plug used as Insert Send/Return
6. RCA pin plug for unbalanced input/output

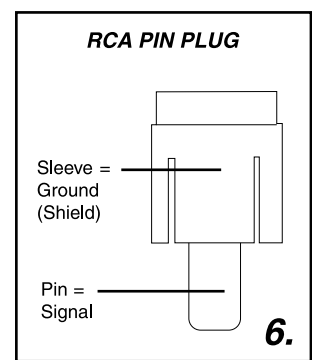
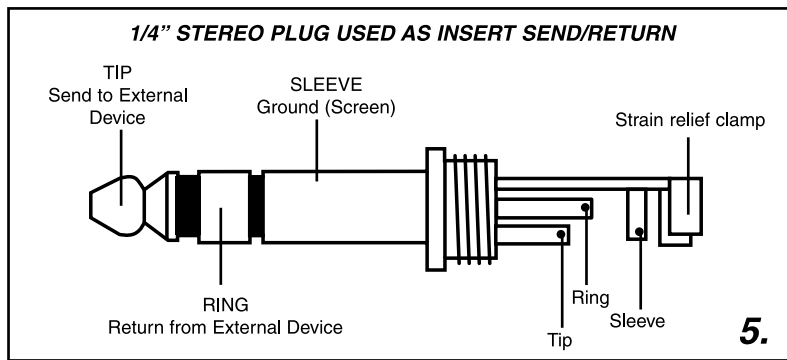
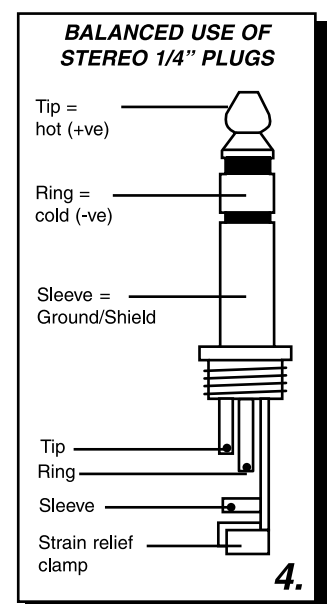
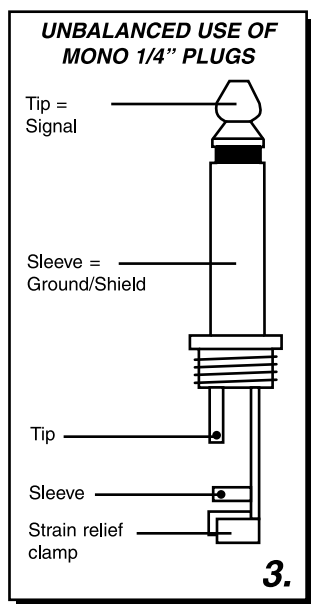
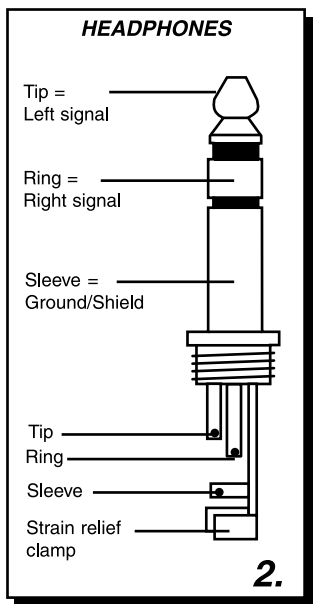
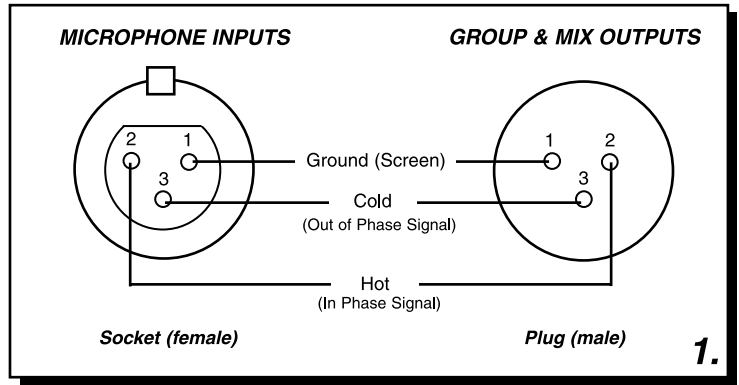

SPECIFICATIONS

1. INPUT SECTION

Input	Connector	Input Impedance	Max Level
MONO CH MIC	XLR BALANCED	3.7K Ω	-10dB (-20dB pad on)
MONO CH LINE	1/4" TRS BALANCED	25K Ω	+19dB (-20dB pad on)
AUX RETURNS	1/4" TS BALANCED	10K Ω	+10dBu
TAPE IN	RCA JACKS	10K Ω	+10dBu

2. OUTPUT SECTION

Output	Connector	Output Impedance	Max Level
MASTER MIX	1/4" UNBALANCED	1K Ω	+21dB
AUX SEND	1/4" UNBALANCED	1K Ω	+21dB
MONITOR OUT	1/4" UNBALANCED	1K Ω	+21dB
TAPE OUT	RCA JACKS	1K Ω	+21dB

3. MIXER SECTION

Frequency Response	20Hz~20KHz (\pm 3dB)
THD	0.07%, 20Hz~20KHz
S/N RATIO	-65dB
NOISE FLOOR	102uV
HIGH EQ \pm 15dB	12KHz
MID EQ \pm 15dB	2.5KHz
LOW EQ \pm 15dB	80Hz
7-BAND EQ \pm 12dB	125Hz, 250Hz, 500Hz, 1KHz, 2KHz, 4KHz, 8KHz, 2 x 5-segment VU meter
PHANTOM POWER	48VDC, globally selected

4. POWER AMP SECTION

POWER OUT	
8 Ω BOTH CHANNELS DRIVEN	200W RMS
4 Ω BOTH CHANNELS DRIVEN	300W RMS
8 Ω BRIDGED	600W RMS
4 Ω BRIDGED	750W RMS
FREQUENCY RESPONSE	20Hz~20KHz \pm 1%
THD	0.5%

5. GENERAL

POWER REQUIREMENTS	Voltage selectable, 115VAC/60Hz or 230VAC /50Hz
FUSE REQUIREMENTS	12.5A 250V FB @ 115VAC; 6A 250V FB @ 230VAC
WEIGHT	SPM 6600: 43 lbs. (19.5 Kg); SPM 8600: 44 lbs. (19.9 Kg)
DIMENSIONS	11.8" x 18.8" x 12" (30.5 cm x 47.7 cm x 30 cm)

The specifications above are correct at the time of printing of this manual. For improvement purposes, all specifications for this unit, including design and appearance, are subject to change without prior notice.

BLOCK DIAGRAM

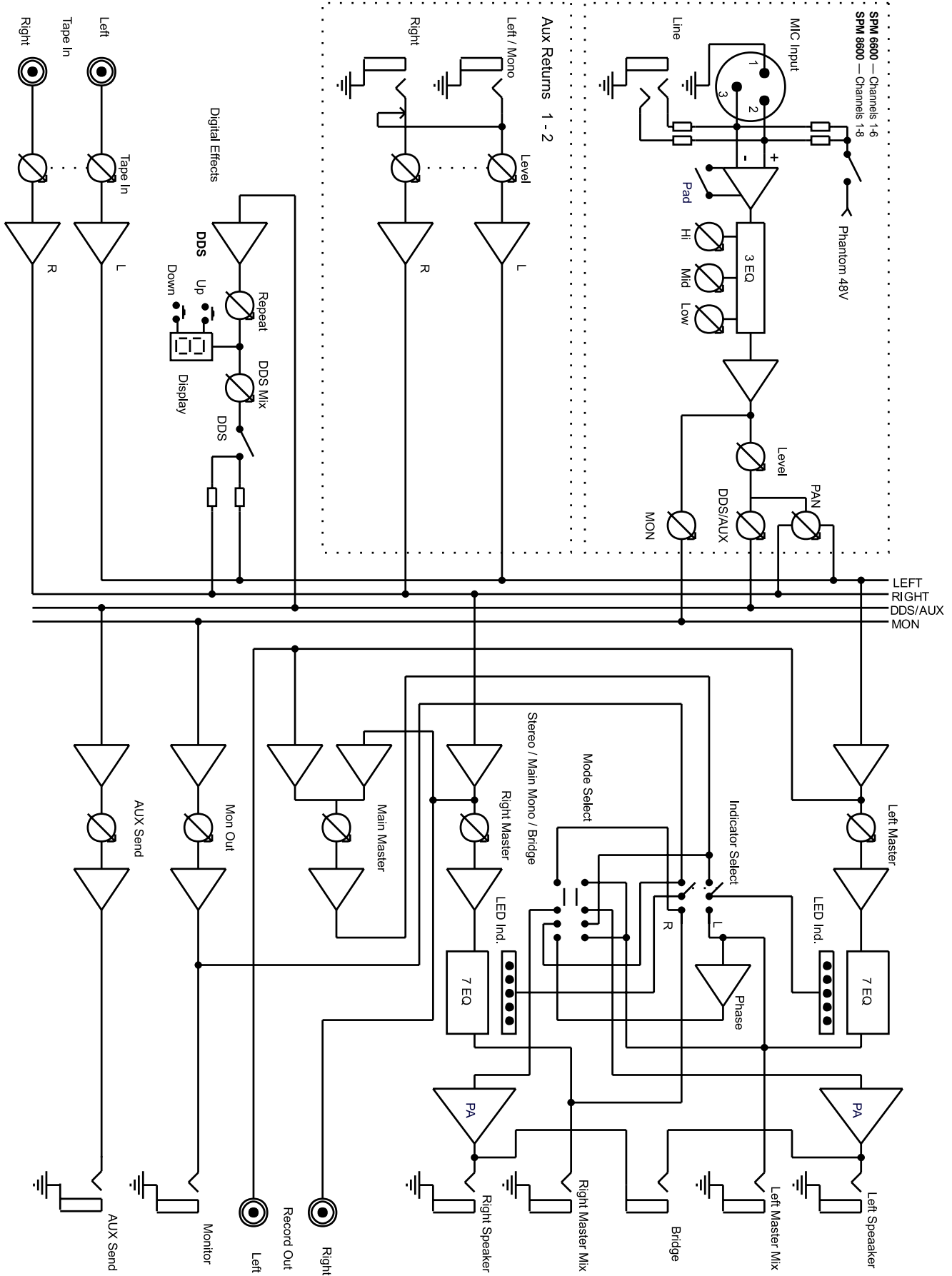

SERVICE FOR YOUR NADY AUDIO PRODUCT

(U.S.) Should your NADY AUDIO product require service, please contact the Nady Service Department via telephone at (510) 652-2411, or e-mail at service@nady.com.

(International) For service, please contact the NADY AUDIO distributor in your country through the dealer from whom you purchased this product.

DO NOT ATTEMPT TO SERVICE THIS UNIT
YOURSELF AS IT CAN BE DANGEROUS AND
WILL ALSO VOID THE WARRANTY.



NADY SYSTEMS, INC. • 6701 SHELLMOUND STREET, EMERYVILLE, CA 94608
Tel: 510.652.2411 • Fax: 510.652.5075 • www.nady.com

Free Manuals Download Website

<http://myh66.com>

<http://usermanuals.us>

<http://www.somanuals.com>

<http://www.4manuals.cc>

<http://www.manual-lib.com>

<http://www.404manual.com>

<http://www.luxmanual.com>

<http://aubethermostatmanual.com>

Golf course search by state

<http://golfingnear.com>

Email search by domain

<http://emailbydomain.com>

Auto manuals search

<http://auto.somanuals.com>

TV manuals search

<http://tv.somanuals.com>