

Computer-Based Instruments

NI 5620 User Manual

Digitizer for PXI™



June 2001 Edition
Part Number 322949B-01

Worldwide Technical Support and Product Information

ni.com

National Instruments Corporate Headquarters

11500 North Mopac Expressway Austin, Texas 78759-3504 USA Tel: 512 794 0100

Worldwide Offices

Australia 03 9879 5166, Austria 0662 45 79 90 0, Belgium 02 757 00 20, Brazil 011 284 5011,
Canada (Calgary) 403 274 9391, Canada (Montreal) 514 288 5722, Canada (Ottawa) 613 233 5949,
Canada (Québec) 514 694 8521, Canada (Toronto) 905 785 0085, China (Shanghai) 021 6555 7838,
China (ShenZhen) 0755 3904939, Denmark 45 76 26 00, Finland 09 725 725 11, France 01 48 14 24 24,
Germany 089 741 31 30, Greece 30 1 42 96 427, Hong Kong 2645 3186, India 91805275406,
Israel 03 6120092, Italy 02 413091, Japan 03 5472 2970, Korea 02 596 7456, Malaysia 603 9596711,
Mexico 5 280 7625, Netherlands 0348 433466, New Zealand 09 914 0488, Norway 32 27 73 00,
Poland 0 22 528 94 06, Portugal 351 1 726 9011, Singapore 2265886, Spain 91 640 0085,
Sweden 08 587 895 00, Switzerland 056 200 51 51, Taiwan 02 2528 7227, United Kingdom 01635 523545

For further support information, see the *Technical Support Resources* appendix. To comment on the documentation, send e-mail to techpubs@ni.com.

Copyright © 2001 National Instruments Corporation. All rights reserved.

Important Information

Warranty

The NI 5620 is warranted against defects in materials and workmanship for a period of one year from the date of shipment, as evidenced by receipts or other documentation. National Instruments will, at its option, repair or replace equipment that proves to be defective during the warranty period. This warranty includes parts and labor.

The media on which you receive National Instruments software are warranted not to fail to execute programming instructions, due to defects in materials and workmanship, for a period of 90 days from date of shipment, as evidenced by receipts or other documentation. National Instruments will, at its option, repair or replace software media that do not execute programming instructions if National Instruments receives notice of such defects during the warranty period. National Instruments does not warrant that the operation of the software shall be uninterrupted or error free.

A Return Material Authorization (RMA) number must be obtained from the factory and clearly marked on the outside of the package before any equipment will be accepted for warranty work. National Instruments will pay the shipping costs of returning to the owner parts which are covered by warranty.

National Instruments believes that the information in this document is accurate. The document has been carefully reviewed for technical accuracy. In the event that technical or typographical errors exist, National Instruments reserves the right to make changes to subsequent editions of this document without prior notice to holders of this edition. The reader should consult National Instruments if errors are suspected. In no event shall National Instruments be liable for any damages arising out of or related to this document or the information contained in it.

EXCEPT AS SPECIFIED HEREIN, NATIONAL INSTRUMENTS MAKES NO WARRANTIES, EXPRESS OR IMPLIED, AND SPECIFICALLY DISCLAIMS ANY WARRANTY OF MERCHANTABILITY OR FITNESS FOR A PARTICULAR PURPOSE. CUSTOMER'S RIGHT TO RECOVER DAMAGES CAUSED BY FAULT OR NEGLIGENCE ON THE PART OF NATIONAL INSTRUMENTS SHALL BE LIMITED TO THE AMOUNT THEREOF PAID BY THE CUSTOMER. NATIONAL INSTRUMENTS WILL NOT BE LIABLE FOR DAMAGES RESULTING FROM LOSS OF DATA, PROFITS, USE OF PRODUCTS, OR INCIDENTAL OR CONSEQUENTIAL DAMAGES, EVEN IF ADVISED OF THE POSSIBILITY THEREOF. This limitation of the liability of National Instruments will apply regardless of the form of action, whether in contract or tort, including negligence. Any action against National Instruments must be brought within one year after the cause of action accrues. National Instruments shall not be liable for any delay in performance due to causes beyond its reasonable control. The warranty provided herein does not cover damages, defects, malfunctions, or service failures caused by owner's failure to follow the National Instruments installation, operation, or maintenance instructions; owner's modification of the product; owner's abuse, misuse, or negligent acts; and power failure or surges, fire, flood, accident, actions of third parties, or other events outside reasonable control.

Copyright

Under the copyright laws, this publication may not be reproduced or transmitted in any form, electronic or mechanical, including photocopying, recording, storing in an information retrieval system, or translating, in whole or in part, without the prior written consent of National Instruments Corporation.

Trademarks

CVI™, LabVIEW™, MITE™, National Instruments™, NI™, ni.com™, PXI™, and RTSI™ are trademarks of National Instruments Corporation. Product and company names mentioned herein are trademarks or trade names of their respective companies.

WARNING REGARDING USE OF NATIONAL INSTRUMENTS PRODUCTS

(1) NATIONAL INSTRUMENTS PRODUCTS ARE NOT DESIGNED WITH COMPONENTS AND TESTING FOR A LEVEL OF RELIABILITY SUITABLE FOR USE IN OR IN CONNECTION WITH SURGICAL IMPLANTS OR AS CRITICAL COMPONENTS IN ANY LIFE SUPPORT SYSTEMS WHOSE FAILURE TO PERFORM CAN REASONABLY BE EXPECTED TO CAUSE SIGNIFICANT INJURY TO A HUMAN.

(2) IN ANY APPLICATION, INCLUDING THE ABOVE, RELIABILITY OF OPERATION OF THE SOFTWARE PRODUCTS CAN BE IMPAIRED BY ADVERSE FACTORS, INCLUDING BUT NOT LIMITED TO FLUCTUATIONS IN ELECTRICAL POWER SUPPLY, COMPUTER HARDWARE MALFUNCTIONS, COMPUTER OPERATING SYSTEM SOFTWARE FITNESS, FITNESS OF COMPILERS AND DEVELOPMENT SOFTWARE USED TO DEVELOP AN APPLICATION, INSTALLATION ERRORS, SOFTWARE AND HARDWARE COMPATIBILITY PROBLEMS, MALFUNCTIONS OR FAILURES OF ELECTRONIC MONITORING OR CONTROL DEVICES, TRANSIENT FAILURES OF ELECTRONIC SYSTEMS (HARDWARE AND/OR SOFTWARE), UNANTICIPATED USES OR MISUSES, OR ERRORS ON THE PART OF THE USER OR APPLICATIONS DESIGNER (ADVERSE FACTORS SUCH AS THESE ARE HEREAFTER COLLECTIVELY TERMED "SYSTEM FAILURES"). ANY APPLICATION WHERE A SYSTEM FAILURE WOULD CREATE A RISK OF HARM TO PROPERTY OR PERSONS (INCLUDING THE RISK OF BODILY INJURY AND DEATH) SHOULD NOT BE RELIANT SOLELY UPON ONE FORM OF ELECTRONIC SYSTEM DUE TO THE RISK OF SYSTEM FAILURE. TO AVOID DAMAGE, INJURY, OR DEATH, THE USER OR APPLICATION DESIGNER MUST TAKE REASONABLY PRUDENT STEPS TO PROTECT AGAINST SYSTEM FAILURES, INCLUDING BUT NOT LIMITED TO BACK-UP OR SHUT DOWN MECHANISMS. BECAUSE EACH END-USER SYSTEM IS CUSTOMIZED AND DIFFERS FROM NATIONAL INSTRUMENTS' TESTING PLATFORMS AND BECAUSE A USER OR APPLICATION DESIGNER MAY USE NATIONAL INSTRUMENTS PRODUCTS IN COMBINATION WITH OTHER PRODUCTS IN A MANNER NOT EVALUATED OR CONTEMPLATED BY NATIONAL INSTRUMENTS, THE USER OR APPLICATION DESIGNER IS ULTIMATELY RESPONSIBLE FOR VERIFYING AND VALIDATING THE SUITABILITY OF NATIONAL INSTRUMENTS PRODUCTS WHENEVER NATIONAL INSTRUMENTS PRODUCTS ARE INCORPORATED IN A SYSTEM OR APPLICATION, INCLUDING, WITHOUT LIMITATION, THE APPROPRIATE DESIGN, PROCESS AND SAFETY LEVEL OF SUCH SYSTEM OR APPLICATION.

Compliance

FCC/Canada Radio Frequency Interference Compliance*

Determining FCC Class

The Federal Communications Commission (FCC) has rules to protect wireless communications from interference. The FCC places digital electronics into two classes. These classes are known as Class A (for use in industrial-commercial locations only) or Class B (for use in residential or commercial locations). Depending on where it is operated, this product could be subject to restrictions in the FCC rules. (In Canada, the Department of Communications (DOC), of Industry Canada, regulates wireless interference in much the same way.)

Digital electronics emit weak signals during normal operation that can affect radio, television, or other wireless products. By examining the product you purchased, you can determine the FCC Class and therefore which of the two FCC/DOC Warnings apply in the following sections. (Some products may not be labeled at all for FCC; if so, the reader should then assume these are Class A devices.)

FCC Class A products only display a simple warning statement of one paragraph in length regarding interference and undesired operation. Most of our products are FCC Class A. The FCC rules have restrictions regarding the locations where FCC Class A products can be operated.

FCC Class B products display either a FCC ID code, starting with the letters **EXN**, or the FCC Class B compliance mark that appears as shown here on the right.

Consult the FCC web site <http://www.fcc.gov> for more information.

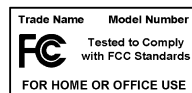

FCC/DOC Warnings

This equipment generates and uses radio frequency energy and, if not installed and used in strict accordance with the instructions in this manual and the CE Mark Declaration of Conformity**, may cause interference to radio and television reception. Classification requirements are the same for the Federal Communications Commission (FCC) and the Canadian Department of Communications (DOC).

Changes or modifications not expressly approved by National Instruments could void the user's authority to operate the equipment under the FCC Rules.

Class A

Federal Communications Commission

This equipment has been tested and found to comply with the limits for a Class A digital device, pursuant to part 15 of the FCC Rules. These limits are designed to provide reasonable protection against harmful interference when the equipment is operated in a commercial environment. This equipment generates, uses, and can radiate radio frequency energy and, if not installed and used in accordance with the instruction manual, may cause harmful interference to radio communications. Operation of this equipment in a residential area is likely to cause harmful interference in which case the user will be required to correct the interference at his own expense.

Canadian Department of Communications

This Class A digital apparatus meets all requirements of the Canadian Interference-Causing Equipment Regulations.

Cet appareil numérique de la classe A respecte toutes les exigences du Règlement sur le matériel brouilleur du Canada.

Class B

Federal Communications Commission

This equipment has been tested and found to comply with the limits for a Class B digital device, pursuant to part 15 of the FCC Rules. These limits are designed to provide reasonable protection against harmful interference in a residential installation. This equipment generates, uses and can radiate radio frequency energy and, if not installed and used in accordance with the instructions, may cause harmful interference to radio communications. However, there is no guarantee that interference will not occur in a particular installation. If this equipment does cause harmful interference to radio or television reception, which can be determined by turning the equipment off and on, the user is encouraged to try to correct the interference by one or more of the following measures:

- Reorient or relocate the receiving antenna.
- Increase the separation between the equipment and receiver.
- Connect the equipment into an outlet on a circuit different from that to which the receiver is connected.
- Consult the dealer or an experienced radio/TV technician for help.

Canadian Department of Communications

This Class B digital apparatus meets all requirements of the Canadian Interference-Causing Equipment Regulations.

Cet appareil numérique de la classe B respecte toutes les exigences du Règlement sur le matériel brouilleur du Canada.

Compliance to EU Directives

Readers in the European Union (EU) must refer to the Manufacturer's Declaration of Conformity (DoC) for information** pertaining to the CE Mark compliance scheme. The Manufacturer includes a DoC for most every hardware product except for those bought for OEMs, if also available from an original manufacturer that also markets in the EU, or where compliance is not required as for electrically benign apparatus or cables.

To obtain the DoC for this product, click **Declaration of Conformity** at ni.com/hardref.nsf/. This website lists the DoCs by product family. Select the appropriate product family, followed by your product, and a link to the DoC appears in Adobe Acrobat format. Click the Acrobat icon to download or read the DoC.

* Certain exemptions may apply in the USA, see FCC Rules §15.103 **Exempted devices**, and §15.105(c). Also available in sections of CFR 47.

** The CE Mark Declaration of Conformity will contain important supplementary information and instructions for the user or installer.

Conventions

The following conventions are used in this manual:

<>

Angle brackets that contain numbers separated by an ellipsis represent a range of values associated with a bit or signal name—for example, DBIO<3..0>.

»

The » symbol leads you through nested menu items and dialog box options to a final action. The sequence **File»Page Setup»Options** directs you to pull down the **File** menu, select the **Page Setup** item, and select **Options** from the last dialog box.



This icon denotes a note, which alerts you to important information.



This icon denotes a caution, which advises you of precautions to take to avoid injury, data loss, or a system crash.

bold

Bold text denotes items that you must select or click on in the software, such as menu items and dialog box options. Bold text also denotes parameter names.

italic

Italic text denotes variables, emphasis, a cross reference, or an introduction to a key concept. This font also denotes text that is a placeholder for a word or value that you must supply.

monospace

Text in this font denotes text or characters that you should enter from the keyboard, sections of code, programming examples, and syntax examples. This font is also used for the proper names of disk drives, paths, directories, programs, subprograms, subroutines, device names, functions, operations, variables, filenames and extensions, and code excerpts.

Contents

Chapter 1

Taking Measurements with the NI 5620

Installing the Software and Hardware	1-1
Acquiring Data with Your NI 5620	1-2
Programmatically Controlling Your NI 5620.....	1-2
Safety Information	1-2

Chapter 2

Hardware Overview

How the NI 5620 Works	2-1
Connecting Signals	2-2
Conditioning the Signal—Impedance, Dither, Gain, and AC Coupling	2-3
Input Impedance	2-3
Dither	2-3
Digitizing the Signal—The ADC	2-3
Incorporating the DDC	2-4
Storing Data in Memory	2-4
Block Diagram	2-5
Other Features	2-6
Multiple-Record Acquisitions	2-6
Triggering	2-7
Calibration	2-7
Synchronizing Multiple PXI Devices	2-8

Appendix A

Specifications

Appendix B

Technical Support Resources

Glossary

Index

Taking Measurements with the NI 5620

Thank you for buying a National Instruments (NI) 5620 digitizer. This chapter provides information on installing, connecting signals to, and acquiring data from the NI 5620.

The NI 5620 has the following features:

- One 14-bit, 64 MS/s analog-to-digital converter (ADC)
- Deep onboard sample memory (amount varies depending on model)

Installing the Software and Hardware

For step-by-step instructions for installing the NI-SCOPE software and the NI 5620, see the *Where to Start with Your NI 5620 Digitizer* document. There are two main steps involved in installation:

1. Install the NI-SCOPE driver. You use NI-SCOPE to write programs to control your NI 5620 in different application development environments (ADEs).
2. Install your Spectral Measurements Toolset (SMT) CD, if included. The SMT provides frequency-domain functionality and examples.
3. Install your NI 5620. See the *Where to Start with Your NI 5620 Digitizer* document.

Acquiring Data with Your NI 5620

You can acquire data programmatically either by writing an application for your NI 5620 or using one of the examples that ships with NI-SCOPE.

Programmatically Controlling Your NI 5620

To help you get started programming your NI 5620, the software comes with examples that you can use or modify.

For time-domain examples, go to the following default locations:

- LabVIEW—Open the Functions palette, and go to **Instrument I/O» Instrument Drivers»NI SCOPE»IF Digitizers**.
- C and Visual Basic—Go to `vxipnp\winXX\Niscope\Examples`.
- LabWindows/CVI—Go to `cvi\samples\Niscope`.

For frequency-domain LabVIEW examples, go to `LabVIEW 6\examples\Spectral Measurements Toolset`. For LabWindows/CVI examples, go to `cvi\samples\smt`.

For more detailed function reference help, see the *NI-SCOPE VI Reference Help*, located at **Start»Programs»National Instruments»NI-SCOPE**.

Safety Information

The following paragraphs contain important safety information that *must* be followed during installation and use of the device.



Caution Do *not* operate the device in a manner not specified in the user manual. Misuse of the device may result in a hazard. The safety protection built into the device may be compromised if it is damaged in any way. If the device is damaged, return it to NI for repair.



Caution If the device is rated for use with hazardous voltages (>30 Vrms, 42.4 Vpp, or 60 VDC), you *must* connect a safety earth ground wire. See Appendix A, *Specifications*, for maximum voltage ratings.



Caution Do *not* substitute parts or modify the device. Use the device only with chassis, modules, accessories, and cables specified in the installation instructions. All covers and filler panels *must* be installed during operation of the device.



Caution Do *not* operate the device in an explosive atmosphere or where there may be flammable gases or fumes. The device can only be operated at or below pollution degree 2, as stated in Appendix A, *Specifications*. Pollution is foreign matter, solid, liquid, or gas that may produce a reduction of dielectric strength or surface resistivity. The following is a description of pollution degrees:

- Pollution degree 1: No pollution or only dry, non-conductive pollution occurs. The pollution has no influence.
- Pollution degree 2: Normally only non-conductive pollution occurs. Occasionally, however, a temporary conductivity caused by condensation must be expected.
- Pollution degree 3: Conductive pollution occurs, or dry, non-conductive pollution occurs, which becomes conductive due to condensation.



Caution Signal connections *must* be insulated for the maximum voltage for which the device is rated. Do *not* exceed the maximum ratings for the device. Remove power from signal lines before connection to or disconnection from the device.



Caution This device can only be operated at installation category I, as stated in Appendix A, *Specifications*. The following is a description of installation categories:

- Installation category IV is for measurements performed at the source of the low-voltage installation. Examples are electricity meters and measurements on primary over current protection devices and ripple control units.
- Installation category III is for measurements performed in the building installation. Examples are measurements on distribution boards, circuit-breakers, wiring, including cables, bus-bars, junction boxes, switches, socket-outlets in the fixed installation, and equipment for industrial use and some other equipment such as stationary motors with permanent connection to the fixed installation.
- Installation category II is for measurements performed on circuits directly connected to the low voltage installation. Examples are measurements on household appliances, portable tools and similar equipment.
- Installation category I is for measurements performed on circuits not directly connected to MAINS. Examples are measurements on circuits not derived from MAINS, and specially protected (internal) MAINS-derived circuits.



Caution Clean the device with a soft non-metallic brush. The device *must* be completely dry and free from contaminants before returning it to service.

Hardware Overview

This chapter provides an overview of the features and functionality of the NI 5620.

How the NI 5620 Works

A signal follows this path through the NI 5620 to your host computer:

1. The signal enters the NI 5620 through the analog front panel connector, INPUT. To find more about the front panel, see the [Connecting Signals](#) section later in this chapter.
2. The signal is filtered and conditioned. Gain and dither are applied to the signal. See the [Conditioning the Signal—Impedance, Dither, Gain, and AC Coupling](#) section for more information.
3. The ADC converts the signal from analog to digital. Refer to the [Digitizing the Signal—The ADC](#) section for more information.
4. (Optional) The digital downconverter (DDC) digitally “zooms in” on data. See the [Incorporating the DDC](#) section.
5. The data is sent to onboard memory (the buffer). See the [Storing Data in Memory](#) section for additional information.
6. The data is transferred to your host computer.

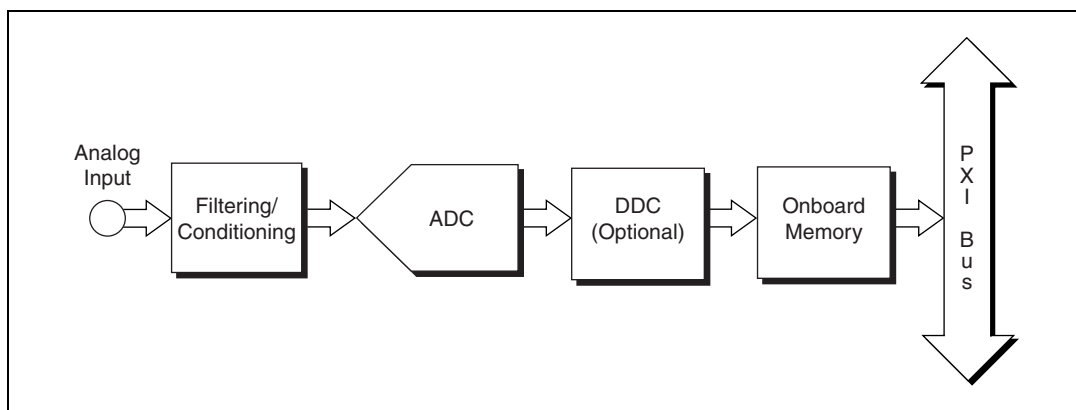

Figure 2-1. Basic Signal Flow

Connecting Signals

Figure 2-2 shows the NI 5620 front panel, which contains three connectors—two SMA connectors and an SMB connector.

One of the SMA connectors, INPUT, is for attaching the analog input signal you wish to measure. The second SMA connector, REF CLK IN, is a 50 Ω , 10 MHz, AC-coupled reference input. The SMB connector, PFI1, is for external digital triggers.

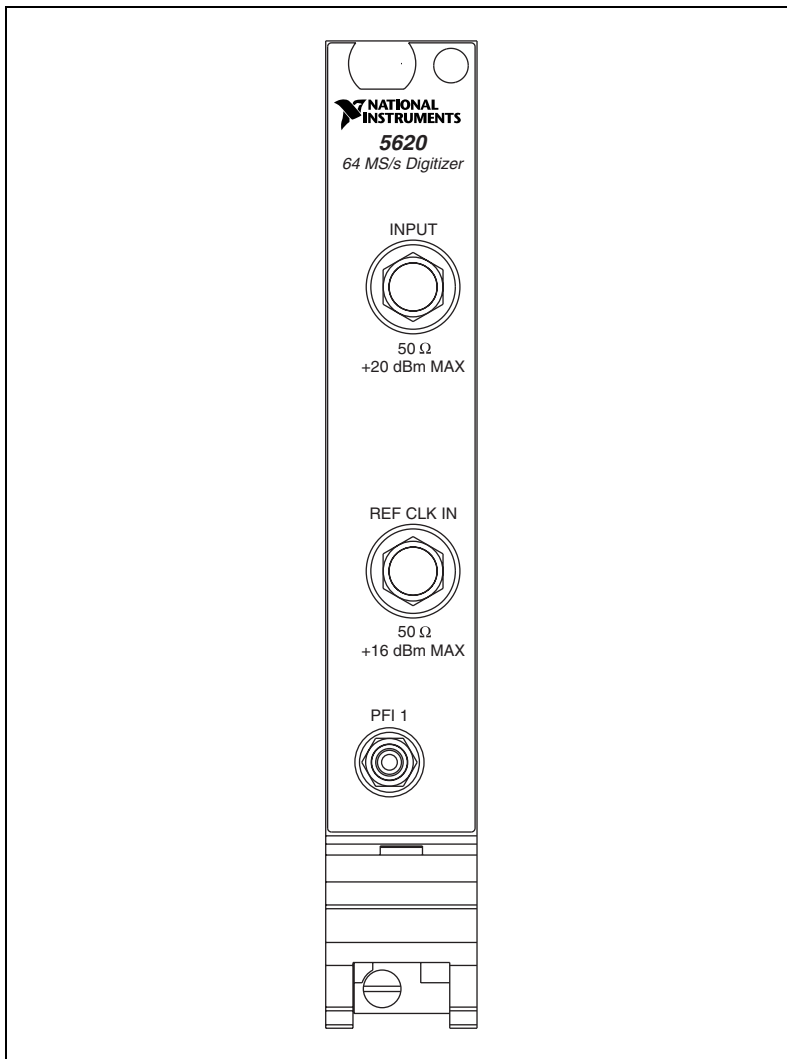

Figure 2-2. NI 5620 Front Panel

Conditioning the Signal—Impedance, Dither, Gain, and AC Coupling

To minimize distortion, signals receive a minimal amount of conditioning. There is one set gain, and all signals are AC coupled, meaning that the NI 5620 rejects any DC portion of a signal. The NI 5620 also has a set input impedance of 50 Ω and applies dither to the configurable signal.

Input Impedance

The input impedance of the NI 5620 is 50 Ω . The output impedance of the source connected to the NI 5620 and the input impedance of the NI 5620 form an impedance divider, which attenuates the input signal according to the following formula:

$$V_m = V_s \times \left(\frac{R_{in}}{R_{in} + R_s} \right)$$

where V_m is the measured voltage

V_s is the unloaded source voltage

R_s is the output impedance of the external device

R_{in} is the input impedance of the NI 5620

If the source whose output you are measuring has an output impedance other than 50 Ω , your measurements will be affected by this impedance divider. For example, if the device has 75 Ω output impedance, your measured signal will be 80% of the value it would have been at 50 Ω .

Dither

Dither is random noise added to the input signal between 0 and 5 MHz. Dither lowers the amount of distortion caused by differential nonlinearity in the ADC when a signal is digitized. When an FFT is applied to the signal, this random noise cancels out most of the distortion created by differential nonlinearity. Dither is not automatically applied, but you can enable it in software.

Digitizing the Signal—The ADC

Regardless of your requested sample rate, the NI 5620 ADC is always running at 64 MS/s. If you request a rate less than 64 MS/s, the timing engine of the NI 5620 stores only 1 sample in a group of n samples, effectively reducing the sample rate to $64/n$ MS/s.

Incorporating the DDC

You may optionally route the data through the DDC before storing it in onboard memory.

The DDC is a digital signal processing (DSP) chip, the Intersil HSP50214B. The first stage uses a digital quadrature mixer that shifts a signal to baseband from any frequency within the digitizer's range. The next stage decimates (reduces the sample rate) by an integer from 4 to 16384. A series of programmable digital lowpass filters prior to each stage of decimation prevents aliasing when the sample rate is reduced. The decimated data may be retrieved as in-phase and quadrature, or as phase and magnitude. A discriminator allows you to take the derivative of the phase to demodulate an FM signal.

By mixing, filtering, and decimating the sampled data, the DDC allows you to zoom in on a band of frequencies much narrower than the Nyquist band of the ADC. The lower sample rate means that signals of longer duration can be stored in the same amount of memory. For spectral analysis, a smaller, faster FFT may be used to look at only the band passed through the DDC.

Refer to the *NI-SCOPE VI Reference Help* for specific DDC attributes you can use to program your NI 5620. If you installed the included measurement software, there is also online help for LabVIEW users using the DDC.

Storing Data in Memory

Samples are acquired into onboard memory on the NI 5620 before being transferred to the host computer. The minimum size for a buffer is approximately 256 samples, although you can specify smaller buffers in software. When specifying a smaller buffer size, the minimum number of points are still acquired into onboard memory, but only the specified number of points are retrieved into the host computer's memory.

During the acquisition, samples are stored in a circular buffer that is continually rewritten until a trigger is received. After the trigger is received, the NI 5620 continues to acquire posttrigger samples if you have specified a posttrigger sample count. The acquired samples are placed into onboard memory. The number of posttrigger or pretrigger samples is limited only by the amount of onboard memory.

Block Diagram

This block diagram is intended for advanced users. An explanation of some of these features follows.

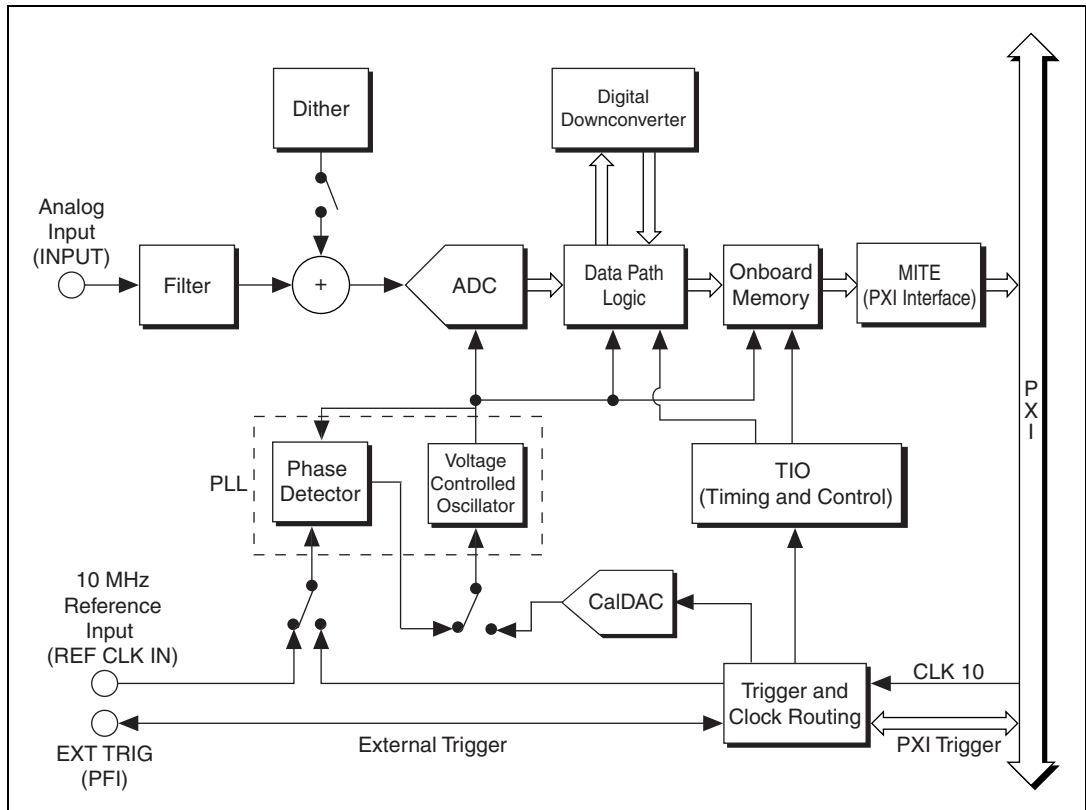

Figure 2-3. Block Diagram

The *digital downconverter* is a digital signal processor (DSP) that allows you to digitally zoom in on data, which reduces the amount of data transferred into memory and speeds up the rate of data transfer. The digital downconverter does this by frequency-translating, filtering, and decimating signals after they go through the ADC. See the [Incorporating the DDC](#) section for more information.

The *PLL* uses a phase detector to synchronize the acquisition clock to either a 10 MHz reference clock supplied through REF CLK IN or to the CLK 10 signal from the PXI backplane. You can also choose to leave the

acquisition clock in a free-running state, in which the acquisition clock is not synchronized to any external reference.

The *voltage controlled crystal oscillator (VCXO)* is a 64 MHz clock.

The *trigger and clock routing area* directs clock signals and triggers.

The *TIO* is the timing engine used for the NI 5620.

The *MITE* is the PXI bus interface. The MITE provides high-speed direct memory access (DMA) transfers from the NI 5620 to the host computer's memory.

Other Features

This section contains information on other features on the NI 5620.

Multiple-Record Acquisitions

After the trigger has been received and the posttrigger samples have been stored, you can configure the NI 5620 to begin another acquisition that is stored in another memory record on the device. This process is a *multiple-record acquisition*. To perform multiple-record acquisitions, configure the NI 5620 to the number of records to be acquired before starting the acquisition. The NI 5620 acquires an additional record each time a trigger is accepted until all the requested records have been stored in memory. After the initial setup, this process does not require software intervention.

Between each record, there is a *dead time* during which the trigger is not accepted. If the record length is greater than 80 μ s, this dead time will be 500 ns. If, however, the record length is less than 80 μ s, the dead time will be 80 μ s. During this time, the memory controller sets up for the next record. There may also be additional dead time while the minimum number of pretrigger samples are being acquired. Figure 2-4 shows a timing diagram of a multiple-record acquisition.

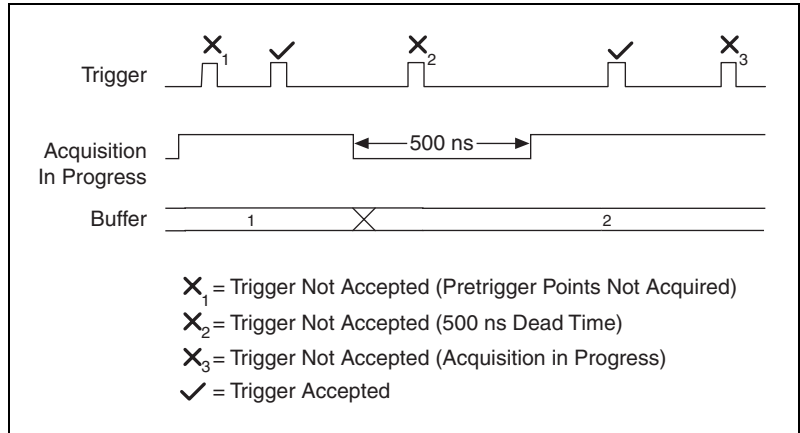

Figure 2-4. Multiple-Record Acquisition Timing Diagram

Triggering

You can externally trigger the NI 5620 through the digital line, PFI1. You can also use software to trigger it. Figure 2-5 shows the different trigger sources. The digital triggers are TTL-level signals with a minimum pulse-width requirement of 100 ns or 16 ns times the DDC decimation.

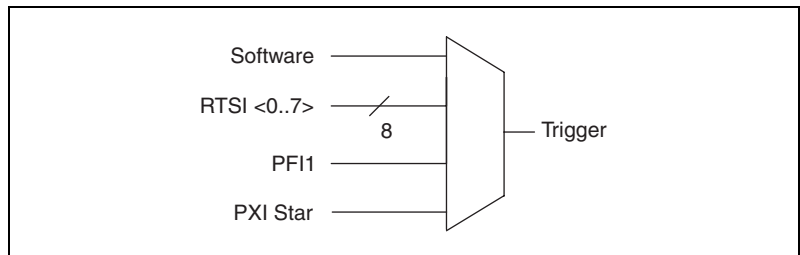

Figure 2-5. Digital Trigger Sources

Calibration

Although the NI 5620 is factory calibrated, it needs periodic calibration to verify that it is still within the specified accuracy. For more information on calibration, contact NI or visit the NI Web site at ni.com.

Synchronizing Multiple PXI Devices

The NI 5620 uses a PLL to synchronize the 64 MHz sample clock to a 10 MHz reference clock. You can either supply the reference clock through the SMA connector (REF CLK IN) on the front panel or use the system reference clock on the PXI backplane.

The PXI bus and the NI 5620 have the following timing and triggering features that you can use for synchronizing multiple digitizers:

- **System Reference Clock**—This is a 10 MHz clock on the PXI backplane with ± 100 ppm accuracy. It is independently distributed to each PXI peripheral slot through equal-length traces with a skew of less than 1 ns between slots. Multiple devices can use this common timebase for synchronization. This allows each NI 5620 to phase lock to the system reference clock.
- **SMA connector (REF CLK IN)**—This is a 10 MHz reference input that you can use to connect your external frequency source for synchronization.

Specifications

This appendix lists the specifications of the NI 5620. These specifications are typical at 25 °C unless otherwise specified.

General Specifications

Number of channels	1
Resolution	14 bits
Max sample rate	64 MS/s (also integer divisions of 64 MS/s)
Onboard memory	
Using DDC (complex data)	8 MS
Not using DDC	16 MS

Input

Signal level	
Nominal	0 dBm (± 0.316 V)
Full-Scale	+10 dBm (± 1.000 V)
Max with dither enabled	+9 dBm (± 0.891 V)
Max non-operating input level	+20 dBm (± 3.16 V)
Max DC input voltage	± 2 V
Input impedance	50 Ω
Coupling	AC
Fully specified frequency range	5 to 25 MHz
Analog bandwidth (-3 dB range)	25 kHz to 36 MHz

VSWR

0.1 to 25 MHz.....< 1.5:1
 25 to 32 MHz.....< 3:1

Dither (can be disabled)

Frequency range15 kHz to 3 MHz

Frequency

Internal Sample Clock

Frequency64 MHz / n , where $1 \leq n \leq 2^{32}$
 Accuracy.....< ± 12 ppm (after calibration)

Noise sidebands

Offset	Density
100 Hz	< -100 dBc/Hz
1 kHz	< -120 dBc/Hz
10 kHz	< -130 dBc/Hz
100 kHz	< -130 dBc/Hz

Residual FM< 2 Hz_{pk-pk} in 10 ms

Amplitude

Average noise density..... -134 dBm/Hz

Spurious responses (0 dBm signal)

5 to 25 MHz, dither enabled.....< -80 dBc
 0.1 to 32 MHz, dither disabled.....-80 dBc

Residual responses (input terminated)....< -85 dBm

Frequency response (5 to 25 MHz)

Relative (to response at 15 MHz)....Less than ± 0.25 dB
 Absolute.....Less than ± 0.5 dB
 Absolute, using calibration tableLess than ± 0.1 dB
 Absolute (0.1 to 32 MHz)..... ± 2.5 dB
 Relative
 (0.1 to 32 MHz, to 15 MHz)..... ± 1.5 dB

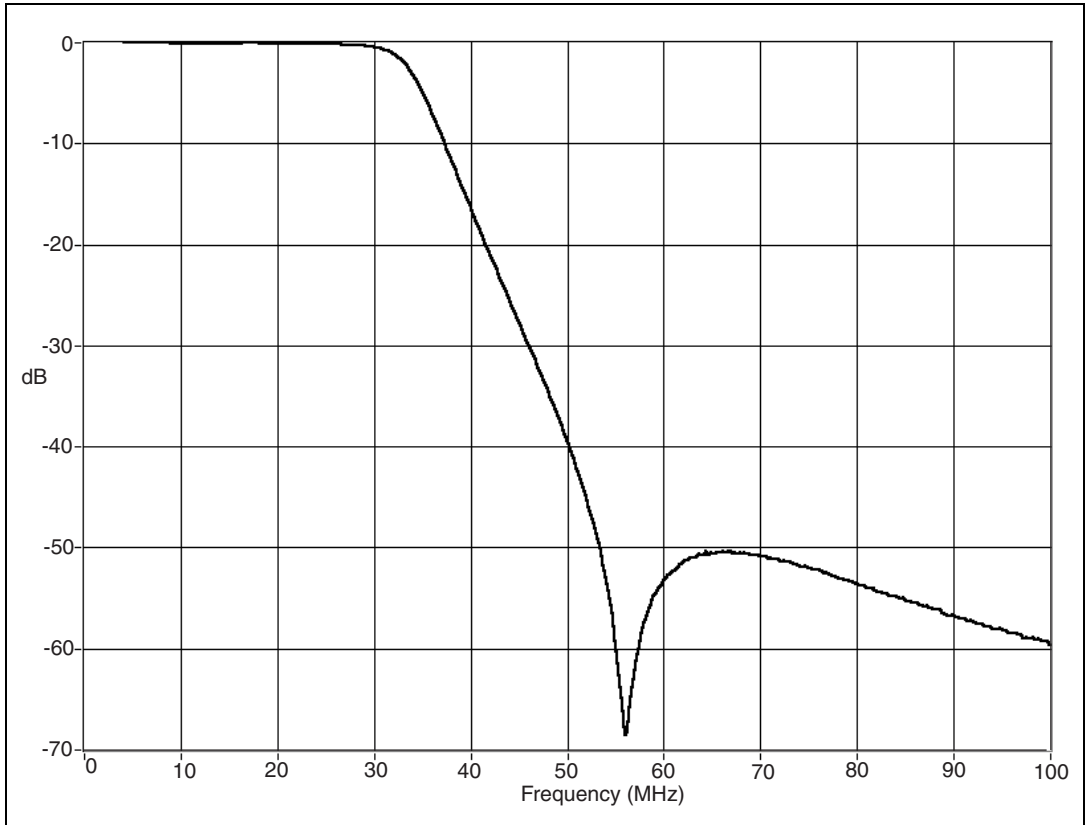

Figure A-1. Frequency Response from 5 to 100 MHz

Phase

Group delay variation
(5 to 25 MHz)..... 9 ns_{pk-to-pk}

Group delay variation
(0.5 to 30 MHz)..... 26 ns_{pk-to-pk}

DDC

Decimation rate with
installed software 32 to 4096

DDC tuning resolution 0.014901 Hz

Triggering

Modes	Immediate, software, digital
Sources.....	PFI 1, RTSI<0..7>, PXI star
Export	RTSI<0..7>, PFI 1
Slope	Rising, falling
Pretrigger depth	Up to 16 MS
Posttrigger depth.....	Up to 16 MS
Minimum pulse width.....	100 ns

PFI 1 Input/Output

PFI 1 Connector.....	SMB male
Trigger level	TTL
Max input voltage	5.5 V

External Frequency Reference Input

Connector (REF CLK IN)	SMA female
Impedance.....	50 Ω
Input amplitude.....	-5 to +15 dBm
Max nonoperating input level	+16 dBm
Max DC input voltage	± 10 VDC
Frequency	10 MHz
Required frequency accuracy	± 40 ppm

Environmental Specifications

Calibration interval	1 year
Warm-up time	10 minutes
Operating environment	
Ambient temperature	0 to 50 °C
Humidity	10 to 90%, noncondensing
Storage environment	
Storage temperature	-20 to 70 °C
Humidity	5 to 95%, noncondensing
Maximum altitude	2000 meters
Pollution degree	2
Indoor use only	

Power Requirements

+3.3 VDC ($\pm 5\%$).....	< 600 mA, 400 mA typical
+5 VDC ($\pm 5\%$).....	< 1.5 A, 1 A typical
+12 VDC ($\pm 5\%$).....	< 450 mA, 330 mA typical
-12 VDC ($\pm 5\%$).....	< 35 mA, 24 mA typical

Maximum Working Voltage

Channel to earth	2 V, Installation Category I
------------------------	------------------------------

Safety

Meets the requirements of the following standards for safety for electrical equipment for measurement, control, and laboratory use:

EN 61010-1:1993/A2:1995, IEC 61010-1:1990/A2:1995,
 UL 3101-1:1993, UL 3111-1:1994, UL 3121:1998,
 CAN/CSA C22.2 no. 1010.1:1992/A2:1997 d.

Electromagnetic Compatibility

CE, C-Tick, and FCC Part 15 (Class A) compliant

Electrical emissionsEN 55011 Class A at 10 m FCC
Part 15A above 1 GHz

Electrical immunityEvaluated to EN
61326:1997/A1:1998, Table 1



Note For full EMC compliance, you must operate this device with shielded cabling. In addition, all covers and filler panels must be installed. See the Declaration of Conformity (DoC) for this product for any additional regulatory compliance information. To obtain the DoC for this product, click **Declaration of Conformity** at ni.com/hardref.nsf/. This Web site lists the DoCs by product family. Select the appropriate product family, followed by your product, and a link to the DoC (in Adobe Acrobat format) appears. Click the Acrobat icon to download or read the DoC.

Dimensions

PXI-5620 (1 PXI slot).....10 cm by 16 cm by 2.0 cm
(3.9 in by 6.3 in by 0.8 in)

Certifications and Compliances

CE Mark Compliance

Conductive Immunity

When tested as specified in EN 61000-4-6 at 3 Vrms, the spurious response will be within specifications except at the test frequency. A spurious signal of up to -45 dBm may appear at the test frequency.

Technical Support Resources

Web Support

National Instruments Web support is your first stop for help in solving installation, configuration, and application problems and questions. Online problem-solving and diagnostic resources include frequently asked questions, knowledge bases, product-specific troubleshooting wizards, manuals, drivers, software updates, and more. Web support is available through the Technical Support section of ni.com.

NI Developer Zone

The NI Developer Zone at ni.com/zone is the essential resource for building measurement and automation systems. At the NI Developer Zone, you can easily access the latest example programs, system configurators, tutorials, technical news, as well as a community of developers ready to share their own techniques.

Customer Education

National Instruments provides a number of alternatives to satisfy your training needs, from self-paced tutorials, videos, and interactive CDs to instructor-led hands-on courses at locations around the world. Visit the Customer Education section of ni.com for online course schedules, syllabi, training centers, and class registration.

System Integration

If you have time constraints, limited in-house technical resources, or other dilemmas, you may prefer to employ consulting or system integration services. You can rely on the expertise available through our worldwide network of Alliance Program members. To find out more about our Alliance system integration solutions, visit the System Integration section of ni.com.

Worldwide Support

National Instruments has offices located around the world to help address your support needs. You can access our branch office Web sites from the Worldwide Offices section of ni.com. Branch office Web sites provide up-to-date contact information, support phone numbers, e-mail addresses, and current events.

If you have searched the technical support resources on our Web site and still cannot find the answers you need, contact your local office or National Instruments corporate. Phone numbers for our worldwide offices are listed at the front of this manual.

Glossary

Prefix	Meanings	Value
p-	pico	10^{-12}
n-	nano-	10^{-9}
μ -	micro-	10^{-6}
m-	milli-	10^{-3}
k-	kilo-	10^3
M-	mega-	10^6
G-	giga-	10^9

Numbers/Symbols

%	percent
+	positive of, or plus
-	negative of, or minus
/	per
°	degree
±	plus or minus
Ω	ohm
<	less than

A

A	amperes
A/D	analog-to-digital
AC	alternating current

AC coupled	allowing the transmission of AC signals while blocking DC signals
ADC	analog-to-digital converter—an electronic device, often an integrated circuit, that converts an analog voltage to a digital number
ADC resolution	the resolution of the ADC, which is measured in bits. An ADC with 16 bits has a higher resolution, and thus a higher degree of accuracy, than a 12-bit ADC.
ADE	application development environment
alias	a false lower frequency component that appears in sampled data acquired at too low a sampling rate
amplification	a type of signal conditioning that improves accuracy in the resulting digitized signal and reduces noise
amplitude flatness	a measure of how close to constant the gain of a circuit remains over a range of frequencies
analog bandwidth	the range of frequencies to which a measuring device can respond
attenuate	to decrease the amplitude of a signal

B

b	bit—one binary digit, either 0 or 1
B	byte—eight related bits of data, an eight-bit binary number. Also used to denote the amount of memory required to store one byte of data.
bus	the group of conductors that interconnect individual circuitry in a computer. Typically, a bus is the expansion vehicle to which I/O or other devices are connected. An example of the PC bus is the PCI bus.

C

C	Celsius
CMOS	complementary metal oxide semiconductor. A process used in making chips.

CMRR	common-mode rejection ratio—a measure of an instrument’s ability to reject interference from a common-mode signal, usually expressed in decibels (dB)
coupling	the manner in which a signal is connected from one location to another
D	
data path logic	a signal router
dB	decibel—the unit for expressing a logarithmic measure of the ratio of two signal levels: $\text{dB}=20\log_{10} V_1/V_2$, for signals in volts
dBm	Decibels with reference to 1 mW, the standard unit of power level used in RF and microwave work. Using this standard, 0 dBm equals 1 mW, 10 dBm equals 10 mW, and so on. In a 50 Ω system, 0 dBm equals $\pm 0.224 V_{\text{rms}}$.
DC	direct current
DDC	<i>See</i> digital downconverter.
dead time	a period of time in which no activity can occur
default setting	a default parameter value recorded in the driver. In many cases, the default input of a control is a certain value (often 0) that means <i>use the current default setting</i> .
differential input	an analog input consisting of two terminals, both of which are isolated from computer ground, whose difference is measured
digital downconverter	a DSP that selects only a narrow portion of the frequency spectrum, thereby eliminating unwanted data before it is transferred into memory
dither	random noise added to a signal before it is digitized to minimize distortion created by differential nonlinearity
DMA	direct memory access—a method by which data is transferred to/from computer memory from/to a device or memory on the bus while the processor does something else. DMA is the fastest method of transferring data to/from computer memory.
double insulated	a device that contains the necessary insulating structures to provide electric shock protection without the requirement of a safety ground connection

drivers software that controls a specific hardware instrument

DSP digital signal processor

E

EEPROM electrically erasable programmable read-only memory—ROM that can be erased with an electrical signal and reprogrammed

F

FFT fast Fourier transform

filtering a type of signal conditioning that allows you to remove unwanted signals or frequency components from the signal you are trying to measure

G

gain the factor by which a signal is amplified, sometimes expressed in decibels

H

hardware the physical components of a computer system, such as the circuit boards, plug-in boards, chassis, enclosures, peripherals, cables, and so on

harmonics multiples of the fundamental frequency of a signal

Hz hertz—the number of scans read or updates written per second

I

I/O input/output—the transfer of data to/from a computer system involving communications channels, operator interface devices, and/or data acquisition and control interfaces

impedance resistance

in. inch or inches

inductance the relationship of induced voltage to current

input bias current	the current that flows into the inputs of a circuit
input impedance	the measured resistance and capacitance between the input terminals of a circuit
instrument driver	a set of high-level software functions that controls a specific plug-in DAQ board. Instrument drivers are available in several forms, ranging from a function callable language to a virtual instrument (VI) in LabVIEW.
interrupt	a computer signal indicating that the CPU should suspend its current task to service a designated activity
interrupt level	the relative priority at which a device can interrupt
ISA	industry standard architecture

L

LabVIEW	a graphical programming language
LSB	least significant bit

M

m	meters
M	(1) Mega, the standard metric prefix for 1 million or 10^6 , when used with units of measure such as volts and hertz; (2) mega, the prefix for 1,048,576, or 2^{20} , when used with B to quantify data or computer memory
MB	megabytes of memory
MITE	MXI Interface to Everything—a custom ASIC designed by NI that implements the PCI bus interface. The MITE supports bus mastering for high-speed data transfers over the PCI bus.
multiple-record acquisition	multiple, distinct chunks (or records) of data

N

noise an undesirable electrical signal—Noise comes from external sources such as the AC power line, motors, generators, transformers, fluorescent lights, soldering irons, CRT displays, computers, electrical storms, welders, radio transmitters, and internal sources such as semiconductors, resistors, and capacitors. Noise corrupts signals you are trying to send or receive.

O

Ohm's Law $(R=V/I)$ —the relationship of voltage to current in a resistance

onboard memory the device memory. Onboard memory is distinct from computer memory.

overrange a segment of the input range of an instrument outside of the normal measuring range. Measurements can still be made, usually with a degradation in specifications.

P

PCI Peripheral Component Interconnect—a high-performance expansion bus architecture originally developed by Intel to replace ISA and EISA; it is achieving widespread acceptance as a standard for PCs and workstations and offers a theoretical maximum transfer rate of 132 Mbytes/s

peak value the absolute maximum or minimum amplitude of a signal (AC + DC)

PFI Programmable Function Input

PLL phase-locked loop

PXI PCI eXtensions for Instrumentation. PXI is an open specification that builds on the CompactPCI specification by adding instrumentation-specific features.

R

R resistor

RAM random-access memory

random interleaved sampling	method of increasing sample rate by repetitively sampling a repeated waveform
real-time sampling	sampling that occurs immediately
record length	the size of a chunk (or record) of data that can be or has been acquired by a device
resolution	the smallest signal increment that can be detected by a measurement system. Resolution can be expressed in bits, in proportions, or in percent of full scale. For example, a system has 12-bit resolution, one part in 4,096 resolution, and 0.0244% of full scale.
rms	root mean square—a measure of signal amplitude; the square root of the average value of the square of the instantaneous signal amplitude
ROM	read-only memory
S	
s	seconds
S	samples
S/s	samples per second—used to express the rate at which an instrument samples an analog signal
sample rate	the speed that a device can acquire data
sense	in four-wire resistance the sense measures the voltage across the resistor being excited by the excitation current
settling time	the amount of time required for a voltage to reach its final value within specified limits
Shannon Sampling Theorem	a theorem stating that a signal must be sampled at least twice as fast as the bandwidth of the signal to accurately reconstruct the signal as a waveform
source impedance	a parameter of signal sources that reflects current-driving ability of voltage sources (lower is better) and the voltage-driving ability of current sources (higher is better)
system noise	a measure of the amount of noise seen by an analog circuit or an ADC when the analog inputs are grounded

T

temperature coefficient	the percentage that a measurement will vary according to temperature. <i>See also</i> thermal drift.
thermal drift	measurements that change as the temperature varies
thermal EMFs	thermal electromotive forces—voltages generated at the junctions of dissimilar metals that are functions of temperature. Also called thermoelectric potentials.
thermoelectric potentials	<i>See</i> thermal EMFs.
TIO	timing input/output. The engine used for timing and control.
transfer rate	the rate, measured in bytes/s, at which data is moved from source to destination after software initialization and set up operations; the maximum rate at which the hardware can operate
trigger	any event that causes or starts some form of data capture
TTL	transistor-transistor logic. A digital circuit composed of bipolar transistors wired in a certain manner.

V

V	volts
V_{AC}	volts alternating current
V_{DC}	volts direct current
V_{error}	voltage error
vertical sensitivity	the smallest voltage change a device can detect
VI	virtual instrument—(1) a combination of hardware and/or software elements, typically used with a PC, that has the functionality of a classic stand-alone instrument (2) a LabVIEW software module (VI), which consists of a front panel user interface and a block diagram program
V_{rms}	volts, root mean square value

W

waveform shape	the shape the magnitude of a signal creates over time
working voltage	the highest voltage that should be applied to a product in normal use, normally well under the breakdown voltage for safety margin

Index

A

AC coupling, 2-3
acquiring data
 multiple-record acquisitions, 2-6
 programmatically, 1-2
ADC, 2-3
amplitude specifications, A-2 to A-3

B

basic signal flow (figure), 2-1
block diagram for NI 5620 digitizer, 2-5 to 2-6

C

calibration, 2-7
certifications and compliances, A-6
conditioning signals
 AC coupling, 2-3
 dither, 2-3
 gain, 2-3
 input impedance, 2-3
conductive immunity, A-6
connecting signals, 2-2
conventions used in manual, *vi*
customer education, B-1

D

data, storing in memory, 2-4
data acquisition
 multiple-record acquisitions, 2-6
 programmatically, 1-2
DDC (digital downconverter)
 incorporating, 2-4
 overview, 2-4
 specifications, A-3

dead time, in multiple-record acquisitions, 2-7
digital downconverter. *See* DDC (digital downconverter).
digitizing the signal (ADC), 2-3
dither, 2-3

E

electromagnetic compatibility, A-6
environmental specifications, A-5
external frequency reference input specifications, A-4

F

frequency specifications, A-2

G

gain, 2-3

H

hardware installation, 1-1
hardware overview, 2-1 to 2-8
 basic signal flow (figure), 2-1
 block diagram, 2-5 to 2-6
 calibration, 2-7
 conditioning signals
 AC coupling, 2-3
 dither, 2-3
 gain, 2-3
 input impedance, 2-3
connecting signals, 2-2
digitizing the signal (ADC), 2-3
incorporating DDC, 2-4
multiple-record acquisitions, 2-6 to 2-7

signal path from NI 5620 to host computer, 2-1
 storing data in memory, 2-4
 synchronizing multiple PXI devices, 2-8
 triggering, 2-7

I

incorporating DDC, 2-4
 input impedance, 2-3
 input specifications, A-1 to A-2
 installing software and hardware, 1-1

M

maximum working voltage, A-5
 MITE interface, 2-6
 multiple-record acquisitions
 overview, 2-6
 timing diagram (figure), 2-7

N

NI 5620 digitizer. *See also* hardware
 overview; specifications.
 acquiring data, 1-2
 block diagram, 2-5 to 2-6
 controlling programmatically, 1-2
 front panel (figure), 2-2
 installing software and hardware, 1-1
 safety information, 1-2 to 1-3
 NI Developer Zone, B-1
 NI-SCOPE driver, 1-1

P

PFI 1 input/output specifications, A-4
 phase detector, 2-5
 phase specifications, A-3
 phase-locked loop (PLL), 2-5
 power requirement specifications, A-5

programmatically controlling the NI 5620, 1-2
 PXI devices, multiple, synchronizing, 2-8

R

REF CLK IN connector, 2-2, 2-8

S

safety information, 1-2 to 1-3
 safety specifications, A-5
 signal conditioning
 AC coupling, 2-3
 dither, 2-3
 gain, 2-3
 input impedance, 2-3
 signal path from NI 5620 to host computer, 2-1
 SMA connectors, 2-2, 2-8
 software installation, 1-1
 specifications
 amplitude, A-2 to A-3
 certifications and compliances, A-6
 conductive immunity, A-6
 DDC, A-3
 dimensions, A-6
 electromagnetic compatibility, A-6
 environmental, A-5
 external frequency reference input, A-4
 frequency, A-2
 general, A-1 to A-2
 input, A-1 to A-2
 maximum working voltage, A-5
 PFI 1 input/output, A-4
 phase, A-3
 power requirements, A-5
 safety, A-5
 triggering, A-4
 storing data in memory, 2-4
 synchronizing multiple PXI devices, 2-8

system integration, by National
Instruments, B-1
System Reference Clock, PXI, 2-9

T

technical support resources, B-1 to B-2
TIO (timing engine), 2-6
trigger and clock routing area, 2-6
triggering

- digital trigger sources (figure), 2-7
- overview, 2-7
- specifications, A-4

V

voltage, maximum working, A-5
voltage controlled crystal oscillator
(VCXO), 2-6

W

Web support from National Instruments, B-1
Worldwide technical support, B-2

Free Manuals Download Website

<http://myh66.com>

<http://usermanuals.us>

<http://www.somanuals.com>

<http://www.4manuals.cc>

<http://www.manual-lib.com>

<http://www.404manual.com>

<http://www.luxmanual.com>

<http://aubethermostatmanual.com>

Golf course search by state

<http://golfingnear.com>

Email search by domain

<http://emailbydomain.com>

Auto manuals search

<http://auto.somanuals.com>

TV manuals search

<http://tv.somanuals.com>