

# **Electra™ 8/24**

**KEY TELEPHONE SYSTEM**

## **INSTALLATION SERVICE MANUAL**

**NEC AMERICA, Inc.**



# INSTALLATION / SERVICE MANUAL CONTENTS

This manual provides the information required to install, program, and maintain the Electra 8/24 Key Telephone System.

This manual is divided into nine chapters as follows:

## CHAPTER 1: SYSTEM DESCRIPTION

Chapter 1 contains general descriptive information about the system, and details the telephone company and FCC requirements.

It also includes feature description, terms, access codes, visual and audible indications, and equipment identification.

## CHAPTER 2: HARDWARE INSTALLATION

Chapter 2 provides the information required to prepare and install the system. It also contains descriptive and installation information for ancillary devices connected to the Key Telephones.

## CHAPTER 3: PROGRAMMING

Chapter 3 provides detailed information about system programming, and explains how to enter the data base record onto the programming sheets (Job Specifications) and into system memory.

## CHAPTER 4: STATION OPERATION

Chapter 4 provides the operation procedures for Key Telephones and Attendant Positions.

## CHAPTER 5: ETI

Engineering Technical Information (ETIs) Bulletins pertinent to this system should be included in this section to provide a complete and updated field book.

**The Electra 8/24 Key Telephone System is also the subject of the following documents:**

ND-20561 Electra 8/24 Key Telephone System General Description.

ND-20564 Electra 8/24 Key Telephone System Circuit Description.

ND-20565 Electra 8/24 Key Telephone System Job Specifications (One copy supplied with each KSU).

ND-20582 Electra 8/24 Key Telephone System Schematic Drawings.



# **CHAPTER 1**

## **SYSTEM DESCRIPTION**



# CHAPTER 1 SYSTEM DESCRIPTION

## TABLE OF CONTENTS

SECTION	DESCRIPTION	PAGE
110	GENERAL .....	100-1
120	REGULATORY INFORMATION	
120.1	General Information .....	100-1
120.2	Company Notification .....	100-1
120.3	Incidence of Harm .....	100-1
120.4	Radio Frequency Interference ....	100-1
120.5	Hearing Aid Compatibility .....	100-2
120.6	Service Requirements .....	100-2
130	GLOSSARY OF ABBREVIATIONS .....	100-2
140	FEATURE DESCRIPTION .	100-3
150	LCD INDICATIONS .....	100-10
160	FEATURE ACCESS CODES (NUMBERING PLAN) .....	100-12
170	EQUIPMENT IDENTIFICATION .....	100-14
170.1	General Information .....	100-15
170.2	Equipment Description .....	100-15

## SECTION 110 GENERAL

The Electra 8/24 Key Telephone System is a high performance, microprocessor based, stored program controlled, Electronic Key Telephone system that provides numerous capabilities for handling both interoffice and outside call traffic.

The Electra 8/24 Key Telephone System offers the flexibility required to meet almost any organization's needs by space division switching technology.

The Electra 8/24 can provide termination for up to 24 stations and 8 Central Office/PBX lines. Each system can be tailored to a customer's needs by use of two types of electronic Key Telephones. There are two possible methods for expanding the system, up to its maximum capacity.

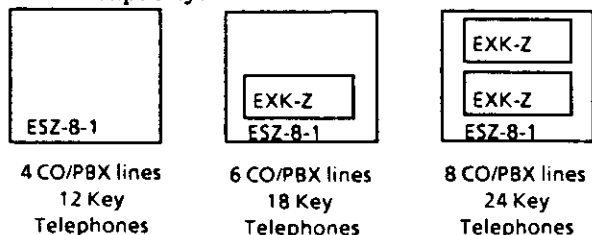


Figure 100-1 System Expansion

The Electra 8/24 is a total communication system that offers a wide variety of features, most of which are standard and available to all stations in the system.

The Electra 8/24 is designed for *ease of operation* and maximum user convenience. Solid state circuitry and a minimum of mechanical components ensure simple maintenance and high reliability.

This chapter of the manual provides full details and requirements needed, prior to the installation of the Electra 8/24.

## SECTION 120 REGULATORY INFORMATION

### 120.1 General Information

The Federal Communications Commission (FCC) has established rules which permit this telephone system to be directly connected to the telephone network. A jack is provided by the telephone company. Jacks for this type of customer provided equipment will not be provided on party lines or coin lines.

The telephone company may make changes in its technical operations and procedures. If such changes affect the compatibility or use of the Electra 8/24, the telephone company is required to give adequate notice of the changes.

### 120.2 Company Notification

Before connecting, or disconnecting, the telephone system to, or from, the telephone network, the telephone company must be provided the following:

1. Your telephone number.
2. FCC registration number:  
AY589N-17672-KF-E or  
AY589N-17673-MF-E \*
3. Ringer equivalence number: 1.5B \*
4. USOC Jack required: RJ11C

\*Items 2 and 3 above, are indicated on the system equipment label.

### 120.3 Incidence of Harm

If the system is malfunctioning, it may also be causing harm to the telephone network. The telephone system should be disconnected until the source of the problem can be determined and until repair has been made. If this is not done, the telephone company may temporarily disconnect service.

### 120.4 Radio Frequency Interface

In compliance with FCC Part 15 rules, the following statement is provided:

#### IMPORTANT NOTE:

*"This equipment generates, uses, and can radiate radio frequency energy and if not installed and used in accordance with the installation service manual, may cause interference to radio communications. This equipment has been tested and approved for*

*compliance with the limits for a Class A computing device pursuant to Subpart J of Part 15 of FCC Rules, which are designed to provide reasonable protection against such interference when operated in a commercial environment. Operation of this telephone system in a residential area, is likely to cause interference, in which case the user, at his or her own expense, will be required to take whatever measures may be required to correct the interference."*

**120.5 Hearing Aid Compatibility**

The key telephones provided for this telephone system are NOT hearing aid compatible. FCC rules prohibit the use of nonhearing aid compatible telephones in the following locations:

1. Any public or semipublic location where coin operated or credit card telephones may be found.
2. Elevators, highways, and tunnels (automobile, subway, railroad, or pedestrian) where a person with impaired hearing might be isolated in an emergency.
3. Places where telephones are specifically installed to alert emergency authorities such as fire, police, or medical assistance personnel.
4. Hospital rooms, residential health care facilities, convalescent homes, and prisons, specifically where telephones are used for signaling life threatening or emergency situations if alternative signaling methods are not available.
5. Workstations for hearing impaired personnel.
6. Hotel, motel, apartment lobbies; in stores where telephones are used by patrons to order merchandise; in public transportation terminals where telephones are used to call taxis, or to reserve lodging or rental automobiles.
7. Hotel and motel rooms. At least ten percent of the rooms must contain hearing aid compatible telephones; or contain jacks for plug in hearing aid compatible telephones which will be provided to hearing impaired customers upon request.

**120.6 Service Requirements**

In the event of equipment malfunction, all repairs will be performed by an authorized agent of NEC America, Inc or by NEC America, Inc. It is the responsibility of users requiring service to report the need for service to one of NEC America, Inc.'s authorized agents or to NEC America, Inc.

**SECTION 130  
 GLOSSARY OF ABBREVIATIONS**

-A-	
ADA	Ancillary Device Adaptor
ATT	Attendant
-B-	
BGM	Background Music
BLF	Busy Lamp Field
-C-	
CO	Central Office
CPU	Central Processing Unit
CNF	Conference
-D-	
DP	Dial Pulse
DSS	Direct Station Selection (also DSS/BLF)
DND	Do Not Disturb
DPH	Door Phone
DTMF	Dual Tone Multi Frequency
-E-	
EXK	Expansion Interface for KTS
EXT	Extension
ESP	External Speaker/Paging Unit
-F-	
FCC	Federal Communications Commission
FWD	Forward
FNC	Function
-G - H-	
HFU	Handsfree Unit (Speakerphone)
-I-	
IC	Integrated Circuit
ICM	Intercom
IDF	Intermediary Distribution Frame
INT	Internal (Calling on Intercom)
-J - K -	
KTU	Key Telephone Unit
-L-	
LED	Light Emitting Diode
LK	Line key
LCD	Liquid Crystal Display
-M-	
MDF	Main Distribution Frame
MSG	Message
MIC	Microphone (Unit & Control Button)
MOH	Music on Hold
-N-	
NBR	Number
-O-	
OCC	Other Common Carriers
-P-	
PR	Power Failure Transfer, Ring Side
PT	Power Failure Transfer, Tip Side
PSU	Power Supply Unit
-S-	
SPKR	Speaker (Control Button)
SCC	Specialized Common Carriers
SPD	Speed Dial
STA	Station
SMDR	Station Message Detail Recorder
-T - U - V - W - X - Y - Z	
TRF	Transfer (Feature)



## SECTION 140 FEATURE DESCRIPTION

**ADD-ON CONFERENCE** provides the ability to converse with up to two additional parties, in any combination of internal and / or outside calls. Conference calls are not amplified and are therefore subject to the quality of the CO/PBX line used.

A conference may consist of:

- 1 station and 2 CO/PBX lines
- 2 stations and 1 CO/PBX line
- 3 stations (no CO/PBX lines)

A maximum of four Conferences can be established in a system at the same time.

**ALPHANUMERIC DISPLAY;** the ETZ-16D-1 Key Telephone is provided with a 16 digit, 7 segment Liquid Crystal Display. The LCD is capable of showing more than 100 fixed and flexible readouts. These displays provide both user convenience and programming guidance.



Figure 100-2 ETZ-16D-1 Key Telephone

**ANCILLARY DEVICE ADAPTOR;** each ETZ-16D-1 Key Telephone can be made to support additional functions / features with the installation of an ADA-Z Unit (Ancillary Device Adaptor). Connection of a jackset for headset use, an external speakerphone, a handset amplifier, etc. can be accomplished with the ADA-Z Unit installed.

**ATTENDANT CALL TRANSFER** permits an attendant to camp a call onto a busy extension. If the transfer is not answered within a preprogrammed time period, the call will return to the attendant position.

A maximum of two **ATTENDANT POSITIONS** are possible in an Electra 8/24 System. The program provides for ports 10 and 11 to be assigned as *Attendant Positions*. The *Attendant Positions* require the use of the ETZ-16D-1 Key Telephone.

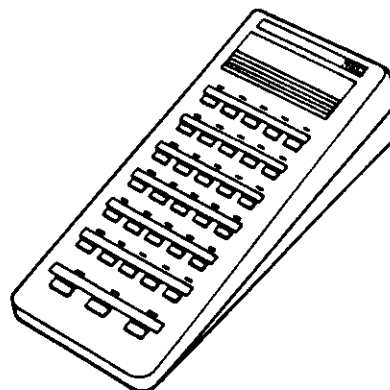


Figure 100-3 EDZ-24-1 DSS/BLF

These positions have access to attendant features, such as setting and displaying *System Speed Dial* memories, setting and leaving *Night Mode*, setting of the system clock, etc.

*Attendant Positions* equipped with the Direct Station Selection/Busy Lamp Field (*DSS/BLF*) Console are able to *Transfer* calls to any extension. The *Transfer* can be by *Voice Announcement*, *Ringing Transfer* (before answer), or after answer by the called station. Unanswered *Attendant Ringing Transfers* Recall to the *Attendant Position*, accompanied by a display identifying the line key number.

**AUTOMATIC CALLBACK** allows users to prompt the system to notify them when a busy extension becomes idle. After calling a busy extension, set an *Automatic Callback* by dialing 0. When both parties are idle, the system will signal the *Automatic Callback* originator first and, after answer, the other station.

**AUTOMATIC HOLD** can be accomplished by depressing a Direct Station Selection button or **Feature Access** key (*Door Phone*, *Page*, and *Call Pickup* buttons) on any Key Telephone. This automatically places a current CO/PBX call on hold, and establishes an intercom call or activates a feature. This provides the station user with one step *Transfer* of calls.

**AUTOMATIC PAUSE - BEHIND PBX** can be inserted into the dialing pattern, to allow for the time needed to access various features of a PBX.

**AUTOMATIC REDIAL** is selected by any station. Key Telephone users access this feature by depressing the **FNC** button and then the **LNR/SPD** button.

If the number being dialed is busy, the system will periodically redial the busy number.

**AUTOMATIC RELEASE** is performed by the system when an outside party abandons the call (for this feature to function, the outside line must provide a timed disconnect signal). It prevents a call from continuing to be connected after the outside party abandons the call.

**BACKGROUND MUSIC - EXTERNAL SPEAKERS** used for paging from the Electra 8/24 System, will be interrupted only to those speakers paged (within a zone). This feature requires a locally supplied music source, paging amplifier, control relays, and the optional ESP-Z KTU.

**BACKGROUND MUSIC - STATION SPEAKER** is provided to all Key Telephone users. The system is designed to accept a separate, locally supplied, music source. Each Key Telephone user can turn on the music source to be heard over their station speaker while their station is idle.

**BATTERY BACKUP - MEMORY** is provided to retain system memory, for up to seven days, during a power outage. The system program, *Clock/Calendar*, and *Speed Dial* are among the items protected.

**BATTERY BACKUP - SYSTEM POWER;** with the built-in backup battery, the system can operate normally for up to 10 minutes, depending on the amount of usage.

**BUSY LAMP FIELD** on the Key Telephone is possible through programming of the **Feature Access** keys or any unused line keys. Any extension programmed to a key, for busy lamp indication, will show a red LED when it is off-hook.

**CALLBACK REQUEST** can be sent to any Key Telephone, when that station is busy, or the user is not available. The LCD of the called ETZ-16D-1 will display the number of the station making the *Callback Request*. Up to three *Callback Requests* can be received at a station.

To leave the *Callback Request*, the caller dials #, after he has reached the station. The FNC LED begins to flash at the called Key Telephone, and then the LCD will display the calling party number.

**CALL FORWARD - ALL CALLS** allows a station to redirect transferred internal ringing calls for their extension to another extension, or to an *Attendant Position*. *Call Forward - All Calls* can be set or canceled by the forwarding station, or an Attendant.

**CALL PICKUP** provides any station the ability to answer an intercom call intended for a different station, by dialing access code 61.



Figure 100-4 ETZ-16-1 Key Telephone

This is provided by assigning stations to Tenant groups, to enable ringing calls in the group to be answered by any station within that group. Each group has access to their own CO/PBX lines. When a line in the group is ringing, any station in the group can dial 66 to answer the call.

A maximum of four *Call Pickup* groups can be assigned in the system.

**CALL TRANSFER** can be performed by any station in the system. Any call can be transferred to any other station in the system.

**CALL WAITING INDICATION** is provided by a flashing ICM LED, when a busy station is called.

**CENTREX RING TONE DISCRIMINATION** is provided to allow a system to follow the ring pattern of CENTREX. This helps a system user to identify the difference between CENTREX internal and external calls.

**CLOCK / CALENDAR DISPLAY** is provided to the ETZ-16D-1 Key Telephone LCD, when the station is idle. During the idle state the LCD will show the MONTH, DATE, and TIME of DAY.

**CODE RESTRICTION with OVERRIDE** aids in the ability to tailor station dialing to every customer's individual needs. The *Restriction* feature provides *Override* capability on a per station and per line basis.

**CONSECUTIVE SPEED DIAL** simplifies dialing complicated sequences of numbers, such as those used for some specialized common carriers.

All Key Telephones have the ability to *Consecutively Speed Dial*, with access to *System* and *Station Speed Dial* memories.

**CONSULTATION HOLD** offers system users the convenience of originating a second call to a station in the system without having to hang up on the party he is speaking with. The station user places his call on hold and originates another call; after consulting with the second party, the station user can initiate a *Conference*, return to the original call, or *Transfer* the call.

**CONVERSATION RECORDING** ability is another user convenience provided by the Electra 8/24 System. Each ETZ-16D-1 Key Telephone is equipped with a mini-jack to accept a locally provided recording device. This will allow a station user to record his or her conversations.

**Caution:** The use of a monitoring device to eavesdrop or record telephone conversations may constitute an illegal invasion of privacy under some circumstances and laws. You should consult a legal advisor prior to implementing any practice involving recording of telephone calls.

FCC order in Docket #20940 permits the use of beep tone or the consent of all parties when conversations are recorded. Section 2510 to 2520 of the U. S. Criminal Code (18U.S.C.2510 et seq.) provides stiff penalties for unauthorized disclosure of wire or oral communications.

**DATA COMMUNICATION CONNECTION** is possible with the Electra 8/24. Users have the ability to establish a data connection, for transmissions to be sent to a data receiving unit requiring DTMF signaling. All stations are able to transmit DTMF signals, including \* and #, to the outside world via the CO Network.

**DIAL 0 for ATTENDANT** speeds the calling process when attempting to reach an Attendant. If the system is configured for two Attendants, **DIAL 0** will enable the user to reach their assigned Attendant.

**DIRECT PAGING ACCESS** can be provided to Key Telephones and/or *DSS/BLF Consoles*, on their **Feature Access** keys.

**DIRECT STATION SELECTION (DSS)** provides one button selection, to rapidly call internal parties, or access system features. The programmable line keys (8 CO/PBX and 8 **Feature Access**) can be assigned for this feature.

**DISTINCTIVE RINGING** helps a user distinguish between outside and internal incoming call signals.

**DO NOT DISTURB (DND)** gives a Key Telephone user the ability to temporarily eliminate all audible

signals for incoming calls to that station. Any of the programmable **Feature Access**, or unused CO/PBX line keys can be programmed for *DND*.

**DOOR LOCK RELEASE** allows any station user to remotely operate a relay, via the Electra 8/24 system's intercom. When the system is equipped with the DPH-Z KTU (*Door/Monitor Phone*) and a locally provided external relay, after calling a Door Phone, any station can dial access code 6 after depressing the FNC button during Door Phone conversation.

**DOOR/MONITOR PHONE** expands the system with up to two internal only communication units. When the system is equipped with the optional DPH-Z KTU and at least one optional DP-A-1 (*Door Phone*) unit, communication from an isolated area (ie, front door) and an extension can be accomplished. This same unit can be used as a one way room *Monitor*.

When the DP-A-1 unit is installed as a *Door Phone*, assigned Key Telephones are signaled by depression of the call button on the *Door Phone* unit. Any station in the system can answer the call and conduct a conversation with the person at the *Door Phone*.

When the DP-A-1 is installed as a room *Monitor* unit, located in the area to be monitored, any station can access the unit and listen to the monitored area.

**DSS/BLF CONSOLE** is a unit that provides twenty three buttons for Direct Station Selection and Busy Lamp Field indication. Each button is equipped with a *Two Color LED*.

Together an ETZ-16D-1 Key Telephone and the EDZ-24-1 *DSS/BLF Console* make an *Attendant Position*. The Console provides the attendant with single button access for up to twenty three extensions, page zones, or other features.

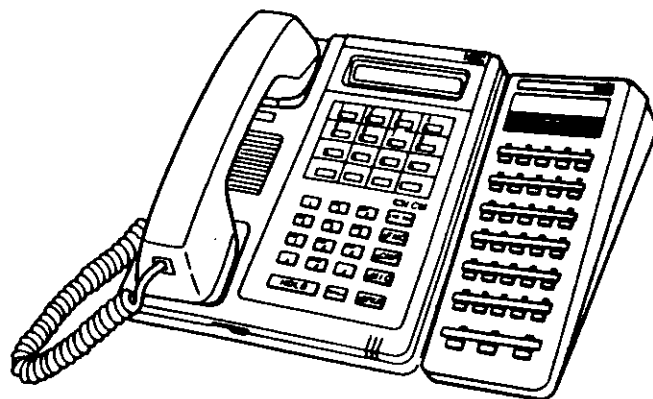


Figure 100-5 Attendant Position

The buttons for *Direct Station Selection*; the associated red and green LED provides the attendant with *Busy Lamp* status and *Message Wait* indication, of the assigned extension.

A maximum of two EDZ-24-1 DSS/BLF Consoles, one per attendant, can be installed in a system.

An ELAPSED CALL TIMER is provided to the LCD of an ETZ-16D-1 Key Telephone, to indicate the amount of time spent on an outside line.

EQUAL ACCESS ACCOMMODATION is provided to permit *Speed Dial* memories, and *Code Restriction* processes to allow connection of CO lines that provide access to Specialized Common Carriers (SCC).

EXTERNAL TONE RING CONTROL is provided by the optional ESP-Z KTU. The *Tone Control* (common CO/PBX audible) to external, locally provided, relays will be activated during CO/PBX incoming ring. The relays will then control a locally provided tone source, or loud ringing bell, generally located in a high noise area.

The relay contacts can be programmed to operate either in day mode or night mode, or both. If programmed for night mode, the relay contacts will only be activated when the system is in night mode.

EXTERNAL ZONE PAGING - MEET ME enables the system users to quickly locate and communicate with each other. The System provides for the ability to have up to two zones (plus all zones) of *External Paging* with the optional ESP-Z KTU installed (with locally provided speakers, relays, and an amplifier).

The ESP-Z KTU provides a 2 Watt amplifier for external speaker paging.

The *Meet-Me* feature provides the ability to answer a page and speak privately with the paging party.

FACSIMILE CONNECTION allows the system to share access of the CO line terminated in KSU port position number four, with a locally provided FAX machine. No additional CO line is required to operate the FAX machine.

FEATURE ACCESS KEYS - USER PROGRAMMABLE, are equipped on each Key Telephone to simplify user operation. Line keys 1 - 8 can be used for CO/PBX lines and/or *Feature Access*. Line Keys 9 - 16 can be used as *Feature Access* keys.

Direct access to all system features, such as *Last CO/PBX Number Redial*, *Call Pickup*, *Paging*, *DSS*, *DND*, etc. can be programmed on these keys.

FLEXIBLE RINGING ASSIGNMENT allows independent ringing assignments for the day and night modes. Day and night ringing assignments are assigned on a per station basis. Any number of stations may be programmed to ring on all CO/PBX lines.

A FLEXIBLE STATION NUMBERING PLAN is assigned by the *Resident System Program* (default) automatically, when the system is first powered up. The default *Station Numbering Plan* is set to provide 10 - 21, for the twelve stations available in the basic KSU; 22 - 27 for the six stations available in the first expansion KTU, and 28 - 33 for the six stations available in the second expansion KTU. The system programmer can alter the *Station Numbering Plan* to include station numbers 10 through 59.

FLEXIBLE TIMEOUTS are provided to allow the system to be altered, via programming, to meet the customer's needs. Standard *Timeouts* are set by the *Resident System Program* upon power up.

FULL HANDSFREE OPERATION is an optional feature that can be accomplished by either of two methods:

1. installation of the HFU-Z unit into an ETZ-16D-1 Key Telephone supplies *Full Handsfree Operation* on both internal and outside calls. A *Microphone Control* button allows muting of the microphone.
2. installation of the ADA-Z unit into an ETZ-16D-1 Key Telephone provides termination points for the connection of a locally provided external speakerphone, for *Full Handsfree Operation* on both internal and outside calls.

GROUP HUNT of stations can be programmed for up to ten consecutively numbered extensions.

Up to five hunt groups can be established in a system. Each group is assigned a pilot number; only extensions 10, 20, 30, 40, and 50 can be assigned as a pilot numbers.

HANDSFREE ANSWERBACK on INTERCOM is a convenience feature provided to each Key Telephone user. Via the Key Telephone's built-in microphone, a station user can respond to an internal voice call without lifting the handset, provided the microphone LED is lit (indicating that the microphone is ON).

HANDSFREE DIALING/MONITORING allows a Key Telephone user to initiate a call and/or monitor a line, without lifting the handset via the station's built-in speaker.

**HOLD (EXCLUSIVE and NONEXCLUSIVE) with RECALL IDENTIFICATION** are features provided to allow for speedy and individualized call handling.

- **EXCLUSIVE HOLD** allows a user to place an ongoing conversation on HOLD while ensuring that no other stations are able to accidentally remove it from HOLD. The holding station's corresponding line key **green** provides a special interrupted wink (*I-HOLD* indication), for easy identification; all other Key Telephones with that appearance have the corresponding LED lit **steadily red** (Busy).

- **NONEXCLUSIVE HOLD** enables a Key Telephone user to place an ongoing conversation on HOLD and allows the user to go to any other Key Telephone, with access to that line, and retrieve the call from hold. The LED indication at the holding Key Telephone is a **green wink**; all other Key Telephones with that line appearance have the corresponding LED with a **red wink**.

- **HOLD RECALL** provides a timed reminder to the user that has forgotten a call placed on HOLD: This *Recall* is provided for both *Exclusive* and *Nonexclusive Hold*. The *Recall* to a station is controlled by a timer that can be programmed by the installer.

The LED at the holding station will change during recall from its **green wink** to a **green flash**; while at the other stations it will remain at the **red wink** rate.

Accompanied, at the holding station, is also an audible recall tone in addition to the change in LED flash rate. The ETZ-16D-1 Key Telephone also receives a *Recall* indication in its display.

**I-HOLD INDICATION** shows a Key Telephone user which lines are being held by that station. The line key LED will be **green** and **winking** at a special interrupted rate.

**INCOMING CALL IDENTIFICATION** provides an ETZ-16D-1 Key Telephone user with a quick reference on the LCD, of who is calling on the intercom, the LCD will show the calling parties' extension number.

**INTERNAL VOICE/TONE SIGNALING** enables a Key Telephone user to select the method of signaling another Key Telephone user.

If the system is programmed for *Voice Announcement*, the calling station can initiate a ringing call instead, by dialing an additional digit after the extension number; or vice versa, if the system is so programmed.

**INTERNAL ZONE PAGING (MEET-ME)** allows anyone within the system to generate a voice page,

via station speakers, to a selected zone (up to three) or to all Key Telephones. Any station can release the page circuit and talk *Privately* with the originator by dialing the *Meet-Me* answer access code 74.

**I-USE INDICATION** shows a Key Telephone user which line he is conversing on. The line key LED will be a **green burst wink**.

**LAST CO/PBX NUMBER REDIAL** allows a station user to redial the last outside number dialed, either with their dial key pad or *Speed Dial*, by depressing two buttons. This feature is accessed by depression of the LNR/SPD button and dial #, or FNC button and dial 5.

**MENU PROGRAM** provides a user friendly format for system programming. *Menu* selections of varied areas in the program are possible. Programming is performed from either of the two *Attendant Positions* (ETZ-16D-1 Key Telephone ports 10 and/or 11) while the system is in full operation.

**MESSAGE WAITING INDICATION** is provided to each Key Telephone to indicate that an attendant has a message for the called station.

When *Message Waiting* is set to a Key Telephone, from a DSS/BLF Console, the LED in the FNC button will **wink**.

**MICROPHONE CONTROL** is provided with a MIC button, on each Key Telephone. The MIC button contains an LED, which when lit indicates the microphone is ON.

The MIC button is used to mute the microphone for *Privacy* during incoming *Voice Announcement* calls and during calls using the optional HFU-Z unit.

**MUSIC ON HOLD** connects a locally provided music source or the synthesized music (provided with the system) to an outside party whenever a call is placed on any type of HOLD.

**NESTING DIAL** is a uniquely developed feature for users that require long numbers to be dialed (more than 22 digits). This feature allows a user to store up to five complete (up to 22 digits each) *Speed Dial* buffers into a sixth buffer.

These numbers can then be successively transmitted by depressing the LNR/SPD button and then dialing the number of the sixth *Speed Dial* buffer.

**NIGHT CHIME** can be provided in systems equipped with the optional ESP-Z KTU, locally provided external relays, and a chime ringer. The ESP-Z KTU

will provide relay control during incoming CO/PBX ring, to the external relay.

**NIGHT TRANSFER** is a function of the *Attendant Positions* (with or without a *DSS/BLF Console*). When an Attendant sets the system into **night mode**, it changes from the **day mode** ring assignment.

**OFF-HOOK RINGING** allows a Key Telephone user to hear when another incoming call is signaling, while the station's handset is in use. The *Off-Hook Ring* is provided through the station's built-in speaker at a reduced volume level.

**PC CONNECTION via MODEM** offers Key Telephone users *Data Communication* capabilities not normally offered in systems of this size. Each ETZ-16D-1 Key Telephone is equipped with a modular jack (CN10), allowing connection of a Modem for data information transfers.

**POWER FAILURE TRANSFER** ensures a customer always has access to the Central Office network, even during a commercial power outage.

This feature requires the use of Single Line Telephones installed specifically for this feature.

During a power outage (for a period longer than the ten minutes protected by the systems *Backup Battery*) selected CO lines are *Transferred* directly to Single Line Telephones with PFT-Z ETU, allowing direct access to the CO network.

**PRIME LINE ASSIGNMENT** simplifies the use of the system, by providing automatic selection of a line key. When a Key Telephone, programmed for *Prime Line Assignment*, goes off-hook, the assigned outside, or extension line or intercom path is seized automatically.

This feature always seizes the line key when the line is **idle**.

**PRIVACY on ALL CALLS** gives the system users the security of knowing that no one can listen in to their ongoing conversation. Only the person conversing can allow another party to enter the conversation, either via *Privacy Release*, or *Add-On Conference*. Selected stations can enter another party's conversation via *Privacy Override*.

**PRIVACY OVERRIDE** enables a Key Telephone to be programmed to allow it to enter another party's conversation without that party's need to invoke the *Privacy Release* feature. To *Override Privacy*, go off-hook on the intercom, depress the **FNC** button, **CNF** button and CO/PBX line key to be *Overridden*.

A programmable alert tone is provided to the *Overridden* station just prior to the *Override* occurring.

This feature does not allow *Override* of a *Private Line*.

**PRIVACY RELEASE** enables a Key Telephone user to allow another party into their *Private CO/PBX* conversation. To *Release Privacy*, depress the **CNF** button, once the third party enters the conversation *Privacy* is again restored.

**PRIVATE LINES** can be assigned to up to a maximum of two Key Telephones. Only the Key Telephone programmed for the *Private Line* feature has access to that line, no LED line status indication is provided to any other station.

**PROGRAMMABLE PAUSE for SPEED DIAL** is especially useful when using *Specialized Common Carrier Access*.

During *Speed Dial* memory programming, each depression of the **LNR/SPD** button will add a *Pause* into the dialing pattern, the duration of the *Pause* is programmable. Each *Pause* entered counts as a digit in the buffer.

**PROGRAMMING by KEY TELEPHONE** of system functions and timers is permitted by either of the two system *Attendant Positions* (ports 10 and 11). An ETZ-16D-1 is required.

**PUSHBUTTON DIALING - DTMF or DP** is provided to all stations, for simplified and speedy calling.

The actual dialing signals transmitted to the CO/PBX network will be consistent with the type of CO/PBX line terminated in the KSU. The Electra 8/24 can accept termination of a combination of DTMF and DP (rotary) CO/PBX lines.

A **RECALL / FLASH BUTTON** is provided on all Electra 8/24 Key Telephones. The **RECALL** button, can be used to generate either a hook flash to access features provided by an outside exchange (CO, PBX, or CENTREX), or to abandon a call while retaining the outside line for origination of another call.

The **RESIDENT SYSTEM PROGRAM** is located in the memory of the system's CPU and enables the system to function fully, after power up. This allows system operation before programming has begun. The installer, therefore, is provided with a method of testing the system for accurate operation, and comparison of his programming.

**RESTRICTION - OUTGOING** is a software function allowing customized and cost effective usage of outside line calling. Assignment is on a per station, per line basis.

**RESTRICTION - TOLL with OVERRIDE** aids in the ability to tailor the station dialing to every customer's individual needs. The Electra 8/24's advanced *Restriction* package helps control outside call usage, based on area codes (*Toll*). Up to six digit restrictions are possible. The *Restriction* feature offers an *Override* capability, to allow *Equal Access* to Secondary Common Carriers.

**RING TONE VARIATION** is a feature provided to Key Telephone users, and is selectable by each user. Each position will provide a different *Ring Tone*. This *Variation* allows users in close proximity of each other to provide themselves with their own distinctive tone, for easy call identification.

**RINGING LINE PREFERENCE** allows the user to answer a ringing call by going off-hook.

A **SECURITY ALARM** feature of the Electra 8/24 System provides two *Alarm* circuits. When activated, these circuits provide an audible tone signal to all idle Key Telephone speakers. The optional DPH-Z KTU contains the two *Security* detecting circuits, and must be installed in the KSU, for this feature to function.

When activated, the *Security Alarm* circuit also provides an LCD indication, showing which Alarm is active, to all idle ETZ-16D-1 Key Telephones. Only the Attendant Key Telephone can cancel (reset) the Alarm signal.

**NOTE:** *This security feature is only an internal problem notification, this should not be used as a primary source of protection.*

**SPEED DIAL - STATION** offers every station in the system access to a personal listing of up to twenty *Speed Dial* memory buffers. Each memory buffer has the capability of storing up to 22 digits, or five other buffer numbers (*Nesting Dial*). Each memory buffer is programmed by the individual station user.

**SPEED DIAL - SYSTEM** offers every station in the system access to an additional commonly used file of eighty *Speed Dial* memory buffers. Each buffer has the ability of storing up to 22 digits. These memory buffers can only be programmed by the Attendant.

**STATION CALL TRANSFER with RECALL IDENTIFICATION** allows a call to be *Transferred* to a station when it is busy or *Ring Transferred* when

idle. If the *Transferred* call is not answered within a preprogrammed period of time, the initiating station is *Recalled*. The *Recall* will be signaled by a distinctive tone and LED flash rate. ETZ-16D-1 Key Telephones additionally receive *Identification* on their LCD, indicating which line is *Recalling*.

**STATION MESSAGE DETAIL RECORDING - SMDR** is provided by the optional SMDR-Z KTU. This KTU provides *Detailed* call *Records* of call activity in the system. *Records* are generated for all outgoing CO/PBX calls. Extension number, CO/PBX line number, date, numbered dialed, time of origination, and call end time are some of the information stored in memory on this KTU. To retrieve this information from memory, a locally provided printing device needs to be connected to the RS-232C output jack from the KTU.

**STEP CALL** allows station users who receive a busy signal when attempting an internal call to another station to *step* the call to the next station (within the same 10 group) by dialing the digit 1.

**TANDEM CONFERENCE** provides the ability for a Key Telephone user to establish a *Conference* with two CO/PBX lines by placing them on hold. The station user can hang up, freeing that station for other uses. The *Conference* may be reentered at any time by the Key Telephone user.

Only one *Tandem Conference* can be in progress at a time.

The *Tandem Conference* feature requires one station position.

**TENANT SERVICE** allows the system extensions to be subdivided into four groups. Each group can have access to their own CO/PBX lines and *Call Pickup Group*.

A **THREE MINUTE REMINDER** can be provided to Key Telephone users that originate and answer CO/PBX calls. This timed signal will alert a user every *Three Minutes* of a CO/PBX call, to help keep the user aware of the length of time they are in conversation.

**TONE OVERRIDE** allows station users to signal a busy extension that they want to reach. This *Tone* signal is heard only by the called and calling extension users.

Once alerted, a Key Telephone user can immediately answer the *Override* by placing the existing call on hold.

**TWO COLOR LEDs** are provided on the line keys of every Key Telephone, to identify the status of different lines. The color **green** is used to show the status of *I-Hold, I-Use, Exclusive Hold, ringing transfers, and Recall*; other status indications are shown in red. The *DSS/BLF Console* is also provided with two color LEDs on *Direct Station Selection* buttons. **green** shows the status of *Message Waiting* and **red** the status of the associated extension.

**USER PROGRAMMING CAPABILITY** reduces installer involvement / time, and permits the user to make their own changes. Users are able to program such features as *Station Speed Dial, Ring Tone, and Background Music* (by dialing an access code).

**VOLUME CONTROL** on each Key Telephone is adjustable by the individual user. Each user can alter the *Volume* of the built-in speaker by adjusting the slide lever, located on the lower front edge of the Key Telephone housing. There is also a three position selector switch located on the bottom of the Key Telephone. This switch enables the user to adjust the ring tone volume.

By depressing the FNC button and dialing the digit 2, the receiving *Volume* level of the station's handset can be adjusted to compensate ICM or CO/PBX line loss.

**WALL MOUNTING - KEY TELEPHONE** permits the mounting of each Key Telephone with the installation of the optional WMU-Z Unit.

### SECTION 150 LCD INDICATIONS

FUNCTION	DISPLAY	MEANING
CLOCK	1-25 23-59 (1-25 11-59P)	•Jan. 25 23:59 (Jan. 25 11:59 p.m.)
CALL DURATION	00-59	•0 minutes 59 seconds
CO/PBX LINE SEIZURE	L1 826-4111	•Accessed L1, CO line number 826-4111
DIALED CO NUMBER	518 444 2783	•Number just dialed
LAST CO/PBX NUMBER REDIAL / SPEED DIAL	Lnr SPd -- Ln. = 518 444 2783 01 = 301 597 2132 01 = nonE	•LNR/SPD button depressed •# depressed after LNR/SPD •Speed Dial buffer 1 accessed, number sent •Speed Dial buffer not programmed, empty
HOLD RECALL	rCL L1	•Recall on Line Key 1
ICM CALL	10 -- [15] 10 = = [15] 15 -- [10] 15 = = [10]	•Extension 10 calling extension 15}LCD of 10 •In conversation •Called by extension 10}LCD of 15 •In conversation
RING TRANSFER	12 -- [17] Co trF	•CO/PBX call transferred from extension 17 to extension 12
TONE OVERRIDE	10 -- [12] t - o 12 -- [10] t - o	•Sending Override Tone to extension 12}LCD of 10 •Override Tone received at extension 12}LCD of 12
AUTOMATIC CALLBACK	45 -- [10] At Cb 45 -- [10]	•Automatic Callback to extension 10 from extension 45 •Called party Callback memory full, request denied
CALLBACK REQUEST	18 -- [21] Cbr 18 -- [21] [13] [18] [44] Cbr SYS CLEAR	•Callback Request to extension 21 from extension 18 •Called party Callback memory full, request denied •Callback Request from extensions 13, 18, and 44 in order of receipt •Callback Request system canceled(Attendant)
DO NOT DISTURB	dnd SET dnd CLEAR	•Set •Canceled

NOTE: The display column shows LCD indications as they appear in the LCD on the Key Telephone.



LCD INDICATIONS CONTINUED

FUNCTION	DISPLAY	MEANING
CALL FORWARD	CF 11--[31] '11'--[21] CF CF CLEAR CF SYS CLEAR	<ul style="list-style-type: none"> <li>●Call Forward to extension 31 from extension 11</li> <li>●Call Forward to extension 21 (calling station)</li> <li>●Call Forward clear</li> <li>●Call Forward system clear (Attendant)</li> </ul>
EXTERNAL PAGING	12--[75] EP ALL 12--[76] EP	<ul style="list-style-type: none"> <li>●All zone paging (calling station)</li> <li>●Zone 1 paging (calling station)</li> </ul>
SELF EXTENSION IDENTIFICATION	12 = Port 10	●Extension 12, port 10
MISTAKE	Error	●Invalid operation
BUSY INTERCOM DATA	buSY	●All intercom paths busy
TIME SET	07-43 P	●Set (7:43 p.m.)
RING TONE ASSIGNED	ring ASSign	●Set
CALL FORWARD CLEAR	CF CLEAR	●Cancel Call Forward
CONFERENCE	[11] [15] CnF '11' [15] [10] 00-59  L1 L2 00-59	<ul style="list-style-type: none"> <li>●ICM conference between extension 11 and 15</li> <li>●Extension 11 on hold</li> <li>●1 CO/PBX - 2 extension Conference, 00-59 is call duration.</li> <li>●2 CO/PBX - 1 extension Conference</li> </ul>
INTERNAL PAGING	12--[70] iP ALL int PAgE 12--[71] iP int PAgE	<ul style="list-style-type: none"> <li>●All zone paging (calling station) 70 is the access code</li> <li>●All zone paging (called stations)</li> <li>●Zone 1 paging (calling station) 71 is the access code</li> <li>●Zone 1 paging (called)</li> </ul>
NIGHT MODE	nt SET nt CLEAR n 1-24 10-59 P	<ul style="list-style-type: none"> <li>●Set (shows for 5 seconds)</li> <li>●Cancel (shows for 5 seconds)</li> <li>●Clock display in night mode on all ETZ-16D-1 TEL</li> </ul>
BGM (STATION)	bAC gnd on bAC gnd off	<ul style="list-style-type: none"> <li>●Set</li> <li>●Clear</li> </ul>
CALLBACK REQUEST RESET	CbrSYS CLEAR	●Callback Request reset - system (Attendant)
FUNCTION LED CLEAR	FnC LEd CLEAR	●Function lamp reset
SPEED DIAL NUMBER CONFIRMATION	xx = nonE	●Speed dial buffer xx has no number programmed
DOOR PHONE	dr PH 1 10 = = dr PH 1	<ul style="list-style-type: none"> <li>●Incoming from Door Phone 1</li> <li>●Extension 10 received the call OR</li> <li>Ext. 10 called Door Phone 1</li> </ul>
FEATURE ACCESS KEY PROGRAMMING (see access code Table)	05 = 0 = 78	<ul style="list-style-type: none"> <li>●05 (Line key number)</li> <li>●0 (Function code)</li> <li>●78 (Feature access number)</li> </ul>
PRIVACY OVERRIDE	P-rLS [ ]	●Privacy Override
SMDR PRINTER	PrintEr tEST PrintEr diSCnCt	<ul style="list-style-type: none"> <li>●Printer test mode</li> <li>●Printer disconnected</li> </ul>
DOOR LOCK RELEASE	door 1 rLS	●Door Lock number 1 released
RING TONE SELECTION	ring ASSign	●Ring assignment/tone selection confirmation
SECURITY ALARM	SEC AL 1	●Security device number 1 activated

NOTE: The display column shows LCD indications as they appear in the LCD on the Key Telephone .

### LCD INDICATIONS CONTINUED

FUNCTION	DISPLAY	MEANING
DATE SET	07-22 3 1987	<ul style="list-style-type: none"> <li>●Set (July 22 Wednesday 1987)</li> <li>0 = Sunday</li> <li>1 = Monday</li> <li>2 = Tuesday</li> <li>3 = Wednesday</li> <li>4 = Thursday</li> <li>5 = Friday</li> <li>6 = Saturday</li> </ul>
SPEED DIAL NUMBER CONFIRMATION	xx = nonE	●Speed dial buffer xx has no number programmed
OFF-HOOK RING ASSIGNMENT	oFF H ringing	●Off-hook ring assignment confirmation
OFF-HOOK RING ASSIGNMENT	oFF H ringing	●Set
CALL FORWARD SYSTEM	CF SYS CLEAR	●System wide cancellation of Call Forward
CALLBACK REQUEST RESET	Cbr SYS CLEAR	●Callback Request reset - system (Attendant)
FUNCTION LED CLEAR	FnC LED CLEAR	●Function lamp reset

NOTE: The display column shows LCD indications as they appear in the LCD on the Key Telephone.

### SECTION 160 FEATURE ACCESS CODES (NUMBERING PLAN)

When Key Telephone is idle:

ACCESS CODE	FEATURE
FNC → 4	Self Extension Number Identification Display
FNC → 65 → FNC	Do Not Disturb (DND) Set/Reset
FNC → 60 → Station Number → FNC	Call Forward
FNC → 68 → FNC	Call Forward Reset - System (Attendant)
FNC → 69 → FNC	Call Forward Reset
FNC → 78 → FNC	Security Alarm Reset (Attendant)
FNC → 80 → FNC	Night Transfer (Attendant) Set and Clear
FNC → 88 → FNC	Callback Request Reset - System (Attendant)
FNC → 93 → FNC	Background Music Selection (On/Off)
FNC → 99 → FNC	FNC Lamp Reset
FNC → 9* → FNC	SMDR Printer Test (Attendant)
FNC → LNR/SPD → xx → yyyy → FNC	Storing Speed Dial into Number Memory - System (Attendant)
FNC → LNR/SPD → xx → yyyy → FNC	Storing Speed Dial into Number Memory - Station
CNF → LNR/SPD → xx	Speed Dial Number Confirmation
FNC → LNR/SPD → * → 1 → x → FNC	Ring Tone Selection
FNC → LNR/SPD → * → 2 → Line Keys → FNC	Ring Assignment (Day)
FNC → LNR/SPD → * → 3 → x → FNC	Off-Hook Ring Assignment
CNF → LNR/SPD → #	Last CO/PBX Number Redial Confirmation

**When Telephone is on the intercom:**

ACCESS CODE	FEATURE
60	Call Pickup - Incoming CO/PBX call from outside of group
61	Call Pickup - Intercom
63 → x	Selection of a designated CO/PBX line
66	Call Pickup - Incoming CO/PBX line inside of group
70	Internal Paging - All Call
71	Internal Zone Paging - Zone 1
72	Internal Zone Paging - Zone 2
73	Internal Zone Paging - Zone 3
74	Meet-Me, Internal and External Page
75	External Page - All Zones
76	External Page - Zone 1
77	External Page - Zone 2
81	Call Door Phone 1
82	Call Door Phone 2
9	CO/PBX line access by a Key Telephone
0	Call for an Attendant
#	Callback Request
*	Tone Override
FNC → CNF → XX → FNC	Privacy Override
1	Step Call from Call Waiting, Voice/Tone Calling

**When Key Telephone is on a CO / PBX line:**

ACCESS CODE	FEATURE
FNC → 2	Receiving Volume Control of the Handset
FNC → LNR/SPD	Automatic Redial
CNF	Privacy Release
FNC → LNR/SPD → XX	To Access Speed Dial Buffer
FNC → 5	Last CO/PBX Number Redial

## SECTION 170 EQUIPMENT IDENTIFICATION

DESIGNATION	DESCRIPTION	MAXIMUM PER SYSTEM
ESZ-8-1 KSU	Key Service Unit	1
EXK-Z KTU	Expansion Key Telephone Unit (six Key Telephones & two CO/PBX lines)	2
DPH-Z KTU	Door Phone Key Telephone Unit	1
ESP-Z KTU	External Speaker Key Telephone Unit	1
SMDR-Z KTU	Station Message Detail Recording Key Telephone Unit	1
PFT-Z KTU	Power Failure Transfer Key Telephone Unit	4
HFU-Z Unit	Handsfree Unit	24
ADA-Z Unit	Ancillary Device Adaptor Unit	24
ETZ-16-1 TEL	Eight Line Key Telephone	24
ETZ-16D-1 TEL	Eight Line Key Telephone with Liquid Crystal Display	24
EDZ-24-1 DSS/BLF	Thirty Three Button Direct Station Selection / Busy Lamp Field Console	2
DP-A-1 Unit	Door Phone	2
WMU-Z Unit	Wall Mounting Unit For a Key Telephone	24
FMU-Z Unit	Floor Mounting Unit for the Key Service Unit	1

## 170.1 GENERAL INFORMATION

A copy of the Job Specifications (ND-20565), an installation instructions sheet, and a KSU wall mounting template are included with the ESZ-8-1 KSU. All optional equipment such as external amplifier, MOH source, BGM source, external speaker, modems, etc. must be locally provided.

## 170.2 EQUIPMENT DESCRIPTION

### 1. ESZ-8-1 KSU

This is the basic system cabinet, that houses the system power supply, *Battery Backup*, termination for up to 4 CO/PBX lines, 12 Key Telephones, *Music On Hold* source, a *FAX* machine, *External Speakers*, *Background Music* source, two *DSS/BLF Consoles*, two synthesized music tunes for *Music On Hold*, etc.

This cabinet houses the MBD(412)-Z KTU, which is the main printed circuit board. The MBD(412)-Z KTU contains the main CPU which controls the system via the various sub-CPU's. This KTU contains several connectors, onto which most of the optional and expansion KTUs mount.

Only 1 ESZ-8-1 KSU can be used in the system.

### 2. EXK-Z KTU

The Key Telephone / CO/PBX Expansion KTU provides system expansion of 2 additional CO/PBX lines and 6 additional Key Telephones.

Up to 2 of these KTUs can be installed in a system. These KTUs mount onto the MBD(412)-Z KTU, in positions CN1,2 and CN3,4.

This KTU contains circuitry for outside line seizure, ring detection, and Dial Pulse dialing conversion. Additionally, this KTU contains a DTMF generation section and supplies power to the Key Telephones terminated to it.

### 3. SMDR-Z KTU

The Station Message Detail Recording KTU stores and generates detailed call records of all outgoing CO/PBX calls.

Information provided by this KTU is:

- Extension Number Calling
- CO/PBX Line Used for The Call
- Start Time of Call
- Time Call Finished
- Number Dialed
- Date of Call

This KTU, maximum of 1 per system, mounts onto the MBD(412)-Z KTU, in position CN11.

A printer or other peripheral recording device must be locally supplied and terminated to the RS-232C connector from the SMDR-Z KTU, located on the J connector guide rail, J4, of the ESZ-8-1 KSU.

### 4. ESP-Z KTU

The External Speaker Control KTU has provision for connection of up to 2 *External Zone Page* speakers to the built-in 1 Watt amplifier, *External Tone Ring* control for *night mode* or high noise area CO/PBX audible signaling, *Background Music* input, and for an external amplifier for talk back page.

A maximum of 1 ESP-Z KTU can be installed in a system. It mounts in the card position next to the battery in the ESZ-8-1 KSU and plugs into CN10 on the MBD(412)-Z KTU.

### 5. PFT-Z KTU

The Power Failure Transfer KTU provides a voice path to a Single Line Telephone during the period when power is completely lost to the system.

Each of the 4 maximum PFT-Z KTUs will transfer CO Tip and Ring for up to 2 Central Office Lines to up to 2 Single Line Telephones.

Up to 2 PFT-Z KTU can be mounted onto the MBD(412)-Z KTU, in position CN15 and CN16. A PFT-Z KTU can be mounted onto each of the EXK-Z KTUs, in position CN6.

The locally provided Single Line Telephones do not operate during normal system operation.

### 6. DPH-Z KTU

The Door Phone / Security Alarm KTU controls the bidirectional internal conversations, and signaling for up to two Door Phone Units (DP-A-1).

This KTU provides 1 speech path that is shared by 2 *Door Phones*, and/or 2 *Security Alarm* sensors, and/or 2 *Room Monitors*, and/or 2 *Door Lock Release* relays. Any combination of these 4 features can be installed, with the limited exception of the *Room Monitor* and *Door Phone* (maximum of 2 combined).

The KTU contains circuitry to allow adjustment of volume of the ring tone to the Key Telephone from the *Door Phone*.

This KTU mounts in the KSU in a position next to the MBD(412)-Z KTU and between it and the ESP-Z KTU, and plugs into the MBD(412)-Z KTU in position CN9.

Only one DPH-Z KTU can be installed in a system.

### 7. DP-A-1 UNIT

This unit is used as a *Door Phone* to originate a tone signal to a preassigned Key Telephone via a call button. This unit is generally installed at front and rear doors of secured work areas. The DP-A-1 Unit is also used as a one way *Room Monitor* to listen to an area.

This unit requires one pair wiring to the MDF for termination into the system.

A maximum of two, weather resistant, DP-A-1 Units can be installed in a system.

#### 8. ETZ-16-1 TEL

This multiline appearance Key Telephone is a fully modular instrument with 8 CO/PBX line keys (each with *Two Color LED*), 7 function buttons, 4 programmable **Feature Access** keys with red LED, 4 programmable **Feature Access** keys without LED, a 3x4 pushbutton dial pad, and an intercom LED.

Line keys LK1 - LK8 can be assigned for CO/PBX line access. If not all 8 CO/PBX ports are installed in the system, then the unused line keys can be programmed for **Feature Access** (*DND, Speed Dial, Door Phone, etc.*).

Line keys LK9 - LK12 can be assigned for *Direct Station Selection (DSS)* with *Busy Lamp* status indication (*BLF*), or any **Feature Access** (*DND, Speed Dial, etc.*).

Line keys LK13 - LK16 can be assigned for **Feature Access** keys to such features as *Speed Dial, Call Pickup, Paging* access, *Direct Station Selection* without *Busy Lamp* status, etc.

This instrument requires twisted two pair cabling to the MDF for termination.

A maximum of 24 ETZ-16-1 Key Telephones can be installed in a system.

#### 9. ETZ-16D-1 TEL

This multiline appearance Key Telephone is a fully modular instrument with 8 CO/PBX line keys (each with *Two Color LED*), 7 function buttons, 4 programmable **Feature Access** keys with red LED, 4 programmable **Feature Access** keys without LED, a 3x4 pushbutton dial pad, an intercom LED, and a 7 segment 16 character *Liquid Crystal Display*. This Key Telephone is also provided with a modular plug for the termination of a modem for data transfer applications, a mini-phono jack for the installation of a recording machine to record telephone conversations, and connectors to accept the optional HFU-Z Unit and the ADA-Z Unit.

Only this type Key Telephone can be installed as an Attendant Key Telephone (ports 10 and 11).

Line keys LK1 - LK8 can be assigned for CO/PBX line access. If not all 8 CO/PBX lines are terminated in the system, then the unused line keys can be programmed for **Feature Access** (*DND, Speed Dial, Door Phone, etc.*).

Line keys LK9 - LK12 can be assigned for *Direct Station Selection (DSS)* with *Busy Lamp* status

indication (*BLF*), or any **Feature Access** (*DND, Speed Dial, etc.*).

Line keys LK13 - LK16 can be assigned for **Feature Access** keys to such features as *Speed Dial, Call Pickup, Paging* access, *DSS* without *BLF* etc.

This instrument requires twisted two pair cabling to the MDF for termination.

A maximum of 24 ETZ-16D-1 Key Telephones can be installed in a system.

#### 10. HFU-Z UNIT

This unit provides the ETZ-16D-1 Key Telephone with *Full Handsfree* operation for both internal and outside calls. It is mounted inside of the Key Telephone, in the compartment located at the bottom of the Key Telephone. The handsfree unit utilizes the Key Telephones' built-in speaker and microphone for the conversations.

A maximum of 1 unit per ETZ-16D-1 Key Telephone can be installed.

#### 11. ADA-Z UNIT

This unit provides the ETZ-16D-1 Key Telephone with termination capabilities for installation, and use of a headset jackset, handset amplifier, or external speakerphone. It is mounted inside of the Key Telephone in the compartment located at the bottom of the Key Telephone.

A maximum of 1 ancillary device can be connected to the ADA-Z Unit. Only 1 ADA-Z unit can be installed in an ETZ-16D-1 Key Telephone.

#### 12. EDZ-24-1 DSS/BLF

This unit provides *Direct Station Selection* with *Busy Lamp Field* indication of up to 23 extensions and nine features.

The first 24 buttons are dedicated to the 23 extensions of the system, providing the Attendant with single button access to every station. Each of these 24 non-locking buttons are associated with a *Two Color LED* located just above the designation strip. The red LED shows the status of the associated station such as *Do Not Disturb (DND)* and busy (in use). The green LED indicates that the Attendant has set a *Message Waiting* indication to the associated station.

The 9 fixed non-locking **Feature Access** buttons are for single button access to several of the system's features, such as *Paging* (one per internal zone and All Call), *Door Phones, Night Transfer, Message set, and All Zone External Page*. Each of these buttons are associated with a red LED which will indicate when these features are in use (busy).

Two EDZ-24-1 *DSS/BLF Consoles* can be installed in a system, 1 per Attendant ETZ-16D-1 Key Telephone. Each EDZ-24-1 is supplied with an AC adaptor, which is to be plugged into the *DSS/BLF Console* and then a nearby 117 volt AC outlet. This adaptor supplies the necessary voltage to light the 33 LEDs on the Console.

Each *DSS/BLF Console* requires twisted one pair cabling run to the MDF for termination to the KSU.

### 13. WMU-Z UNIT

This unit enables a Key Telephone to be wall mounted. It is constructed of a matching color and material as the Key Telephone.

### 14. FMU-Z UNIT

This unit enables the Key Service Unit to be mounted on the floor, when wall mounting is not possible.

This unit requires an installation space of at least 510mm (20") wide, by 240mm (9 19/32") deep, by 516mm (20 5/8") high, to allow for its installation and minimum area to work on the equipment.





# **CHAPTER 2**

# **HARDWARE INSTALLATION**

(

(

f

# CHAPTER 2 HARDWARE INSTALLATION

## TABLE OF CONTENTS

SECTION	DESCRIPTION	PAGE
<b>210</b>	<b>GENERAL</b>	<b>200-1</b>
<b>220</b>	<b>SPECIFICATIONS</b>	
220.1	General Information	200-1
220.2	Programming Station	200-1
220.3	Determination of Equipment Required	200-1
220.4	Power Requirements	200-2
220.5	Grounding Requirements	200-4
220.6	Electrical Noise Generators	200-4
220.7	Additional Equipment	200-4
220.8	Installation Configuration Example	200-4
220.9	System Capacity	200-4
220.10	Cabling Requirements	200-6
220.11	Environmental Conditions	200-6
220.12	Dimensions and Weights	200-6
220.13	Outside Line Type	200-6
220.14	Network and Control	200-6
220.15	Visual and Audible Indications	200-6
220.16	Dialing Specifications	200-6
220.17	Battery Backup	200-7
220.18	External Equipment Interfacing	200-9
<b>230</b>	<b>SITE PREPARATION and MDF/IDF CONSTRUCTION</b>	
230.1	General Information	200-10
230.2	Site Survey	200-10
230.3	Site Limitations	200-10
230.4	Site Selection Conditions	200-10
230.5	MDF Construction	200-10
230.6	KSU Cables	200-11
230.7	Outside Lines	200-11
230.8	Station Equipment	200-11
<b>240</b>	<b>KEY SERVICE UNIT CONNECTION</b>	
240.1	Opening the KSU Cover	200-12
240.2	Wall Mounting the KSU	200-12
240.3	Floor Mounting the KSU	200-14
240.4	KTU Installation Notes	200-15
240.5	Mounting the KTUs	200-15
240.6	Connection of the J Connectors	200-16
240.7	Cabling Route in the KSU	200-16
240.8	Common Control KTU	200-16
240.9	Interface KTUs	200-18
<b>250</b>	<b>POWER SUPPLY INSTALLATION</b>	<b>200-22</b>
<b>260</b>	<b>ANCILLARY DEVICE CONNECTION</b>	
260.1	General Information	200-22
260.2	Handsfree Unit (HFU-Z)	200-23
260.3	Ancillary Device Adaptor Unit (ADA-Z)	200-23
260.4	Wall Mount Unit Installation	200-24
260.5	Connection of a DSS/BLF Console	200-24
260.6	Connection of a Recording Device and a Modem	200-25

## SECTION 210 GENERAL

This chapter provides the reader with comprehensive details of how to properly install each of the Electra 8/24 Key Telephone System components.

It is recommended that this chapter be read in its entirety to familiarize yourself with its contents. This will enable a faster, more productive installation and cut-over.

*Power being supplied to the system should be applied as the final step, just prior to the system operational testing.*

The Key Telephone Units (KTUs) make extensive use of CMOS technology. **STATIC DISCHARGES TO ANY KTU MUST BE AVOIDED.**

The MBD(412)-Z and SMDR-Z KTUs contain a battery to protect the memory of that KTU. To ensure memory retention the switch (SW1) must be ON.

## SECTION 220 SPECIFICATIONS

### 220.1 GENERAL INFORMATION

Prior to configuring any system, first complete the job specification sheets (ND-20565) provided with the KSU, a sample is in Section 370 of this manual, ensure all type of station equipment and feature options are taken into account.

An understanding of the system programming is required to properly complete the job specification forms (Refer to Chapter 3).

### 220.2 PROGRAMMING STATION

A maximum of two programming positions can be available in a system. Station equipment connected to the programming positions must be an ETZ-16D-1 Key Telephone. These two programming positions are system attendants and are fixed in system software as Key Telephone ports 10 and 11.

Only one programming Key Telephone can be off-line at a time.

### 220.3 DETERMINATION of EQUIPMENT REQUIRED

#### 1. Station Equipment

Determine the type and the quantity of each station being installed.

Types of station equipment available are as follows:

- a. ETZ-16-1 TEL  
 8 line Key Telephone  
 ●8 line keys with *Two Color LED* indication for CO/PBX line access  
 ●8 programmable **Feature Access** keys
- b. ETZ-16D-1 TEL  
 8 line Key Telephone with LCD  
 ●8 line keys with *Two Color LED* indication, for CO/PBX line access  
 ●8 programmable **Feature Access** keys  
 ●LCD to indicate station dialing and feature status
- c. EDZ-24-1 DSS/BLF Console

**2. Interface KTU**

To determine the quantity of required interface KTUs, refer to Table 200-1.

For reference, mounting location of interface KTUs are shown in Figure 200-1, front view of ESZ-8-1 KSU, and Table 200-4, connector assignments.

**3. ESZ-8-1 KSU**

- a. This Key Service Unit (KSU) houses the KTUs required for controlling the Electra 8/24 System.
- b. The KSU has a built-in power unit (PSZ-8-1 PSU) which supplies power to all KTUs and Key Telephones, and a battery to backup full operation of the system for 10 minutes, during a commercial power failure.
- c. The MBD(412)-Z KTU, accommodates 4 CO/PBX lines and 12 Key Telephones.
- d. Various units to be installed in the KSU are shown on Table 200-3.

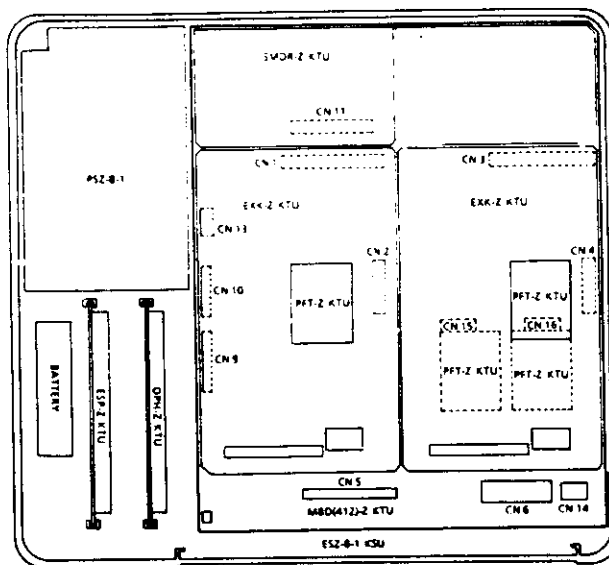
**4. Optional Equipment**

Table 200-2 shows the optional equipment that can be mounted into Key Telephones.

**Table 200-2 Optional Equipment**

OPTIONAL UNIT	KEY TELEPHONE	
	ETZ-16-1	ETZ-16D-1
HFU-Z UNIT	NC	C
ADA-Z UNIT	NC	C

NC = Not connectable    C = Connectable



**Figure 200-1 Front View of ESZ-8-1 KSU**

**220.4 POWER REQUIREMENTS**

The system must have a dedicated ground nominal 117VAC ± 10% outlet separately fused for 5 AMPS.

The AC outlet must be a standard 125 Volt 15 Amp three prong type, which provides circuit ground. If circuit ground is not available, a locally provided frame ground to earth ground connection must be provided (See paragraph 220.5).

**Table 200-1 KTU IDENTIFICATION**

KTU	DESCRIPTION	MAXIMUM KTUs per SYSTEM
EXK-Z KTU	This unit is used to provide 2 additional CO/PBX line ports and 6 additional Key Telephone ports.	2
DPH-Z KTU	This unit allows communication with up to 2 Door Phones. The unit has relays to release 2 Door Locks, and has 2 security interface circuits.	1
ESP-Z KTU	This unit has termination for 2 external speakers for paging and BGM, an external bell control, and termination for a external paging amplifier.	1
SMDR-Z KTU	This unit processes call information, and sends ASCII data to a printer.	1
PFT-Z KTU	This unit switches 2 CO/PBX lines to 2 SLTs to originate and receive calls and converse during a power failure.	4

**Table 200-3 SYSTEM COMPONENTS**

MODEL	MAXIMUM QUANTITY	DESCRIPTION
ESZ-8-1 KSU	1	Electra 8/24 Key Service Unit
PSZ-8-1 PSU	1	Power Supply Contained in KSU
PE07-12R	1	System Backup Battery in KSU
MBD(412)-Z KTU	1	Main Key Telephone Unit Contained in KSU
EXK-Z KTU	2	Key Telephone CO/PBX Expansion Unit
SMDR-Z KTU	1	Station Message Detail Recorder Unit
DPH-Z KTU	1	Door Phone Interface Unit
ESP-Z KTU	1	External Paging Unit
PFT-Z KTU	4	Power Failure Transfer Unit

**Table 200-4  
MBD(412)-Z CONNECTOR IDENTIFICATION**

CONNECTOR	PURPOSE
CN1	EXK-Z KTU
CN2	EXK-Z KTU
CN3	EXK-Z KTU
CN4	EXK-Z KTU
CN5	J1 (Station)
CN6	Four CO/PBX lines
CN7	NOT PROVIDED
CN8	NOT PROVIDED
CN9	DPH-Z KTU
CN10	ESP-Z KTU
CN11	SMDR-Z KTU
CN12	NOT PROVIDED
CN13	Power Supply
CN14	FAX Machine
CN15	PFT-Z KTU
CN16	PFT-Z KTU

It is recommended that the best locally available AC surge protection be installed at the AC power outlet.

The AC power must be within the limits shown in Table 200-5.

**1. AC Input (PSZ-8-1 PSU)**

- a. 117 V AC  $\pm 10\%$ , 60 Hz  $\pm 10\%$ , single phase
- b. A dedicated outlet, separately fused and grounded, is required.

**2. Power Consumption Table 200-5**

CURRENT DRAW	POWER DISSIPATION
AC : 0.5A	200 BTU

**Table 200-6 MBD(412)-Z Switch Identification**

SWITCH	PURPOSE
SW1	Memory retention, always keep ON
SW2	Synthesized Music On Hold (left = Green Sleeves, right = Two Minuets)
SW3	CO/PBX line 1, external pad control, OFF = 0 dB loss, ON = 3 dB loss
SW4	CO/PBX line 2, external pad control, OFF = 0 dB loss, ON = 3 dB loss
SW5	CO/PBX line 3, external pad control, OFF = 0 dB loss, ON = 3 dB loss
SW6	CO/PBX line 4, external pad control, OFF = 0 dB loss, ON = 3 dB loss

**3. Power Supply Outputs Table 200-7**

DC VOLTAGE	MAXIMUM CURRENT
+13.7V $\pm 0.3V$	1.4 A
+5V $\pm 0.25V$	0.5A

**4. Fuse Replacement**

For fuse replacement specifications, refer to Table 200-8.

**Table 200-8 PSZ-8-1 FUSE REPLACEMENT**

FUSE#	SPECS	PURPOSE	SIZE
F1	125V, 2A	AC INPUT	5.2mm X 20mm
F2	125V, 5A	DC OUTPUT	5.2mm X 20mm

### 220.5 GROUNDING REQUIREMENTS

The KSU must be properly grounded. If circuit ground is not available at the dedicated AC outlet, the following steps should be taken:

1. Provide a cold water pipe ground in accordance with the local operating telephone company procedures.
2. If no cold water pipe ground is available, a ground rod should be installed in accordance with the local operating telephone company procedures.
3. Where a ground other than circuit ground is used, a grounding terminal is provided on the PSZ-8-1 in the KSU as shown in Figure 200-2.

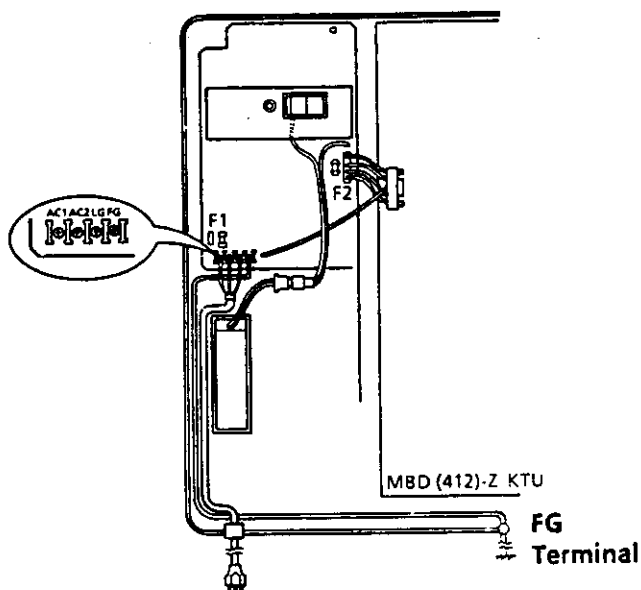


Figure 200-2 KSU Grounding

### 220.6 ELECTRICAL NOISE GENERATORS

Certain equipment, such as welding machines, thyristor driven power supplies, large electric motors, etc., generate electrical noise. As a stored program machine, the Electra 8/24 Electronic Key Telephone System is vulnerable to this noise. When this type of machinery is present at an installation, the following precautionary steps are urged:

1. Locate the KSU, telephones, and cabling away from these machines.
2. If cables must pass near these machines, use shielded cable with the shield grounded.
3. Ensure all machines of this type are well grounded to a separate ground, to minimize noise interference.

### 220.7 ADDITIONAL EQUIPMENT

Along with station equipment, the KSU and its components, other equipment is required. This includes cables, modular connecting jacks, quick connect blocks, etc. This additional equipment must be locally supplied.

### 220.8 INSTALLATION CONFIGURATION EXAMPLE

Table 200-9 provides an example to help understand some of the configuring requirements of the system. In the example, 6 CO lines, 12 Key Telephones without optional equipment, 2 Key Telephones with HFU-Z unit, 2 Key Telephones with ADA-Z unit, 2 external speakers for zone paging, 2 DSS/BLF Consoles, 2 Door Phones, and SMDR are being installed. Refer to Figure 200-3 (System Block Diagram) for a conceptual understanding of the system.

### 220.9 SYSTEM CAPACITY

1. The Electra 8/24 Electronic Key Telephone System capacities are as follows:

- a. Outside lines: 8 lines max.
- b. Intercom paths: 5 max. (4 if BGM (station speaker) is used)
- c. Stations: 24 max.
- d. DSS/BLF Console: 2 max.
- e. System Speed Dial: 80 buffers (22 digits each).
- f. Station Speed Dial: 20 buffers each station (22 digits each).
- g. Conference circuits: 4 max.

2. The basic central equipment (KSU) of this telephone system contains one Main Board Unit with provision for up to 2 expansion units.

- a. MBD(412)-Z KTU: 4 CO/PBX lines and 12 Key Telephones
- b. MBD(412)-Z KTU + One Expansion KTU (EXK-Z): 6 CO/PBX lines and 18 stations.
- c. MBD(412)-Z KTU + Two Expansion KTUs (EXK-Z): 8 CO/PBX lines and 24 stations.

3. Combinations of *System Speed Dial* memory numbers can be assigned to *Station Speed Dial* (*Nesting Dial* memory assignment). By using this technique, more than a 22 digit number can be available for *Speed Dialing*.

Table 200-9 System Configuration (Example)

DEVICE	FUNCTION QUANTITY	REQUIRED UNITS	REQUIRED QUANTITY	REMARKS
Key Service Unit	1	ESZ-8-1 KSU	1	Contains MBD(412)-Z KTU
Power Unit	1	PSZ-8-1 PSU	1	Contained in KSU
CO Line	6			4 CO/PBX line ports on the MBD(412)-Z KTU
Key Telephone	16	EXK-Z KTU	1	12 Key Telephone ports on the MBD(412)-Z KTU
DSS/BLF Console	2			Connects to a Key Telephone port
Door Phone	2	DPH-Z KTU	1	Mounts in the KSU
External Speaker	2	ESP-Z KTU	1	Mounts in the KSU
Station Message Detail Recorder	1	SMDR-Z KTU	1	Mounts on the MBD(412)-Z KTU
Handsfree Unit	2	HFU-Z UNIT	2	Installs into the ETZ-16D-1 Key Telephone
Ancillary Device Adaptor	2	ADA-Z UNIT	2	Installs into the ETZ-16D-1 Key Telephone for connection of ancillary equipment
Key Telephone	12	ETZ-16-1	12	
Key Telephone	4	ETZ-16D-1	4	
DSS/BLF Console	2	EDZ-24-1	2	
Door Phone	2	DP-A-1	2	

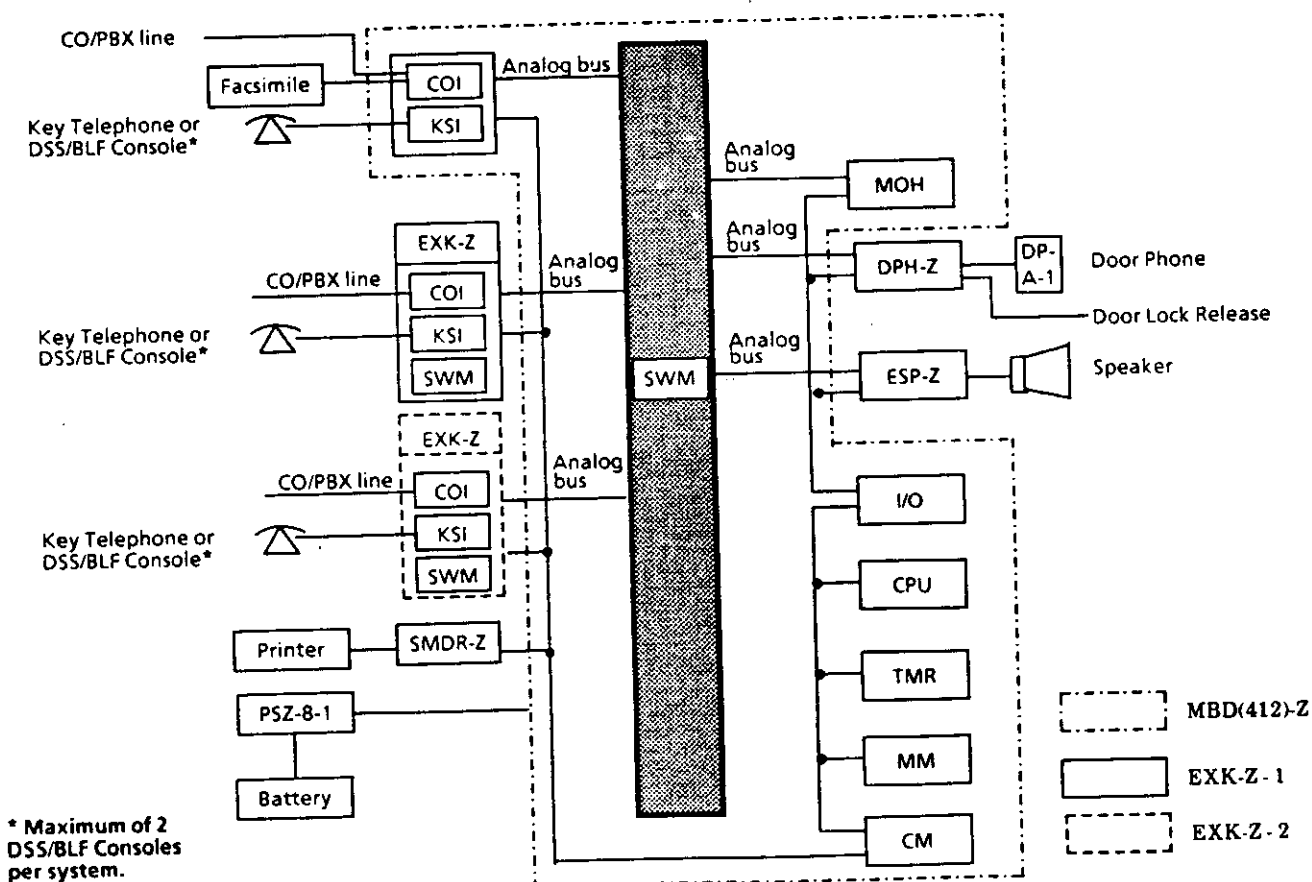


Figure 200-3 System Block Diagram

**220.10 CABLING REQUIREMENTS**

The KSU can be equipped with three 50 position miniature ribbon type (female) amphenol connectors. 50 position miniature ribbon type connector (male) ended cables are required for connection to the Main Distribution Frame (MDF).

Allowable loop resistance, length, and type of station cable is as follows:

1. Maximum Loop Resistance and Cable Length, using 24 AWG
  - a. ETZ-16-1: 40 ohms/825 feet (250m)
  - b. ETZ-16D-1: 40 ohms/825 feet (250m)
  - c. DSS/BLF Console: 40 ohms/825 feet (250m)
2. Cable Type
  - a. Key Telephone: Twisted 2 pair
  - b. DSS/BLF Console: Twisted pair
  - c. Music Source: Hi-Fi type shielded audio cable
  - d. External amplifier: Hi-Fi type shielded audio cable

**220.11 ENVIRONMENTAL CONDITIONS**

1. Temperature
  - a. Operating: 32°F - 104°F (0°C - 40°C)
  - b. Recommended long term: 50°F - 90°F (10°C - 32.2°C)
2. Humidity
 

Operating: 10% - 90% relative, non-condensing

**220.12 DIMENSIONS and WEIGHTS**  
 Table 220-10

COMPONENT	SHIPPING WEIGHT (kg)	HEIGHT (mm)	WIDTH (mm)	DEPTH (mm)
ESZ-8-1 KSU	8 lbs 8 oz (4.0)	16" (400)	17 1/2" (440)	3 1/4" (80)
ETZ-16-1 TEL	2 lbs (0.9)	3 7/8" (97)	6 1/4" (156)	9 1/8" (228)
ETZ-16D-1 TEL	2 lbs 3 oz (1.0)	3 7/8" (97)	6 1/4" (156)	9 1/8" (228)
EDZ-24-1 DSS/BLF	14 oz (0.4)	3 7/8" (98)	2 5/8" (66)	9 1/4" (230)
DP-A-1	5 oz (0.2)	5 1/4" (130)	3 7/8" (98)	1 1/8" (28)
FMU-Z	7 lbs 7 oz (3.5)	20 5/8" (516)	20 3/8" (510)	9 1/2" (240)

**220.13 OUTSIDE LINE TYPE**  
 Two wire, loop start lines.

**220.14 NETWORK and CONTROL**

1. Control
  - a. Control: Stored program with distributed processing
  - b. Central Processor: 8 bit microprocessor
  - c. Clock: 6 MHz
  - d. Interface KTU (EXK-Z): 4 bit 1 chip microprocessor
  - e. Key Telephone: 4 bit 1 chip microprocessor
  - f. DSS/BLF Console: 4 bit 1 chip microprocessor
2. Telephones
 

Key Telephones:

  - Voltage: +10 - +13.7 VDC
  - Max. current: 100 mA

Acoustic characteristics meet Electronic Industry Association (EIA) standard proposal SP-1286 and standard EIA RS-470.

**220.15 VISUAL and AUDIBLE INDICATIONS**

1. Visual Indications
 

LED indications on a Key Telephone shown in Table 200-12.
2. Audible Indications
 

Audible indications from a Key Telephone shown in Table 200-15.
3. EDZ-24-1 Visual Indications
 

LED (BLF) indications on a DSS/BLF (EDZ-24-1) Console shown in Tables 200-13 and 14 respectively.

**220.16 DIALING SPECIFICATIONS**

Table 200-11

Nominal High Group Frequencies (Hz)

		1209	1336	1477
Nominal Low Group Frequencies (Hz)	697	1	2	3
	770	4	5	6
	852	7	8	9
	941	*	0	#

1. Dial Pulse Address Signaling
  - a. Pulse rate: 10 pps/20 pps
  - b. Percent break: 61 ± 3 percent
  - c. Interdigital interval: nominal 800 mS



**2. DTMF Address Signaling**

**a. Frequencies**

Two sinusoidal signals, one from a high group of three frequencies and one from a low group of four frequencies.

**b. Frequency deviation:** Less than  $\pm 1.5\%$

**c. Signal level:**

• Nominal level per frequency: -6 - -4 dBm

Minimum level per frequency:

• Low group: -10 dBm

• High group: -8 dBm

Maximum level per frequency pair:

+2 dBm

**d. Rise time:** Within 5 mS

**e. Duration of dual frequency signal:**

• Default: 100 mS

• Maximum: 300 mS

**f. Interdigital time:**

• Default: 100 mS

• Maximum: 300 mS

**3. Dialing Memories**

**a. Station Speed Dial:** 20 buffers (22 digits each) per station

**b. System Speed Dial:** 80 buffers (22 digits each) per system

**c. Last CO/PBX Number**

Redial: 1 per station (22 digits max.)




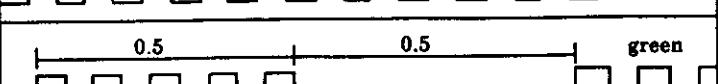
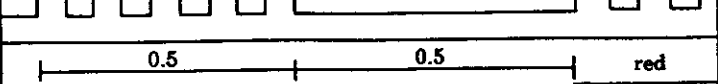
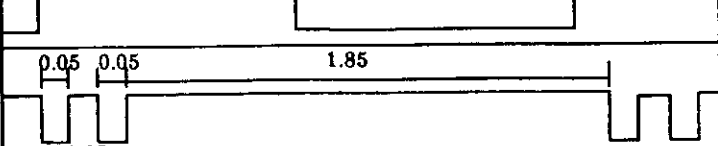
**220.17 BATTERY BACKUP**

1. Backup Battery power is provided on the MBD(412)-Z KTU. This battery, when fully charged, retains program memory contents for approximately 7 days when power is removed from the system.

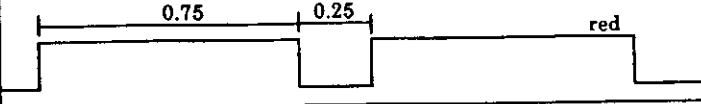

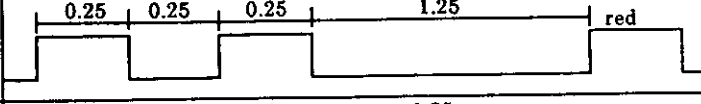

2. A Backup Battery is provided to retain system operation for up to 10 minutes during power outages. Functions receiving Backup with Battery power are as follows:

- a. System Program
- b. Speed Dial Memories (System and Station)
- c. Night Transfer Status
- d. Call Forwarding
- e. Clock/Calendar
- f. Callback Request
- g. Do Not Disturb


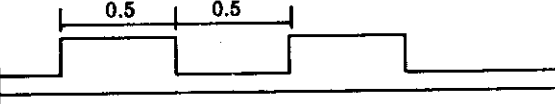

**Table 200-12 LED Flash Patterns (Key Telephone)**

Usage	Cycle (Unit: second)	Duty Cycle
In Use	red	Steady light
Hold		(0.25 sec ON, 0.25 sec OFF)
I-Hold, Exclusive hold		Blinking at 2 Hz intervals
Ringing transfer		10 Hz flash (0.05 sec ON, 0.05 sec OFF)
Hold Recall, Exclusive hold Recall		Flashing at 10 Hz intervals
Automatic redial, Privacy Release, Termination (CO/PBX, intercom)		(0.5 sec ON, 0.5 sec OFF)
I-Use (green) Do Not Disturb (red)		Special wink

**Table 200-12 (Cont'd.) LED Flash Patterns (Key Telephone)**

Usage	Cycle (Unit: second)	Duty Cycle
Call Forward All		(0.75 sec ON, 0.25 sec OFF)
Message display from DSS/BLF		(0.25 sec ON, 0.75 sec OFF)
Add-On hold, intercom hold, Callback request		Blinking at 2 Hz intervals
Conference Hold (called side)		Blinking at 2 Hz intervals

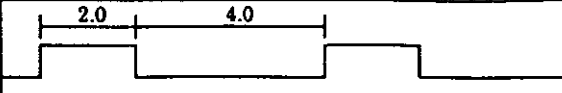
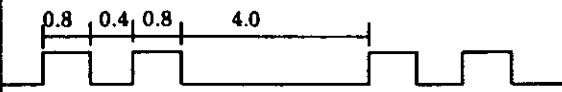
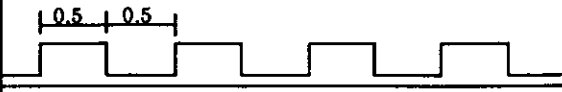
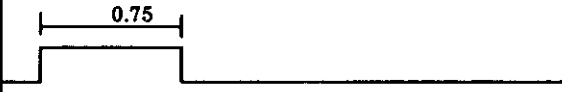

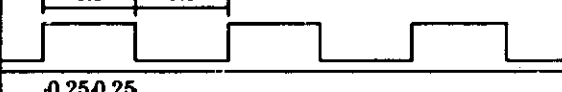
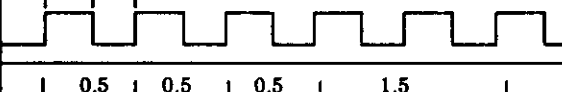
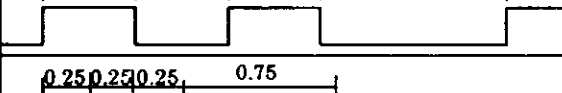
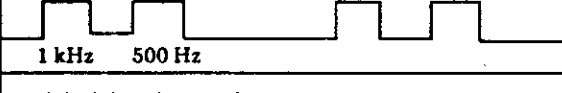
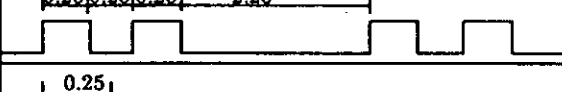
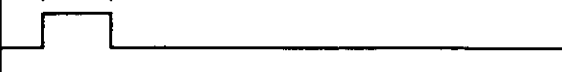
**Table 200-13 LED Flash Patterns (DSS/BLF Console)**

Usage	Cycle (Unit: second)	Duty Cycle
In Use		Steady light
Station Programming Mode		1 Hz wink (0.5 sec ON, 0.5 sec OFF)
Do Not Disturb Call Forward All		2 Hz blink (0.25 sec ON, 0.25 sec OFF)

**Table 200-14 LED Indications (DSS/BLF Console)**

LED Indication	ON	1 Hz	2 Hz	OFF
BLF	Busy	Station Programming Mode	DND, Call Forward All	Idle
Message	Message being set			
Paging	Paging			No paging
Night	Night mode			Day mode
Door Phone	Busy	Key Tel Ringing		Idle
Message display (Green)	Message			No message

**Table 200-15 Tone Patterns (Key Telephone)**

Tone	Cycle (Unit: second)	Frequency
CO/PBX Ring Tone		500 Hz/1 kHz 500 Hz/2 kHz 1kHz/2kHz 10 Hz Modulation
CENTREX Ring Tone		500 Hz/1 kHz 500 Hz/2kHz 1kHz/2kHz 10 Hz Modulation
Transfer Ring		500 Hz/1 kHz 10 Hz Modulation
ICM Dial Tone		500 Hz
Tone Burst, Tone Override		500 Hz
Busy Tone		500 Hz
Call Waiting Tone, Hold Recall Tone		1 kHz
Error Tone		1 kHz
ICM Ring Tone		500 Hz
Door Phone Call Tone from Busy Station		500 Hz/1 kHz 1 kHz 500 Hz
Security Alarm Tone		1 kHz/2 kHz 10 Hz Modulation
3 Minute Alarm		1 kHz

**220.18 EXTERNAL EQUIPMENT INTERFACING**

**1. Music on Hold (MOH)**

- a. Auxiliary input: 0.1 V RMS signal level
- b. Input impedance: 10 k ohms

**2. SMDR Output**

Female connector (System output), Standard RS-232C

**3. External Paging (Audio)**

- a. Output power: 2 Watts maximum – 10.0 dBm signal level
- b. Output impedance: 600 ohms or 8 ohms

**4. Station BGM Input**

- a. Auxiliary input: -10.0 dBm signal level
- b. Input impedance: 40 k ohms

**5. External Paging, MOH, and Ring Contacts**

Contact rating: 500 mA, 24V DC

## SECTION 230 SITE PREPARATION and MDF / IDF CONSTRUCTION

### 230.1 GENERAL INFORMATION

This section presents a survey of the planning details that should be considered prior to installing an Electra 8/24 Key Telephone System. Detailed planning in advance of the actual installation will help ensure that minimum time and cost are incurred and, concurrently, will cause a minimum disruption of the customer's business activities. Additional benefits of a well planned and executed installation include flexibility for changes and expansion at minimum cost, efficient maintenance, and increased customer satisfaction.

### 230.2 SITE SURVEY

In most cases, a survey of a customer's premises is needed to develop a cost estimate for the installation. This data should be used in the site selection of the Main Distribution Frame (MDF), and possible IDF locations. This information will provide the basis for planning an orderly and efficient installation.

For example, the collected data about the job site will generally permit the MDF to be preassembled at the installer's shop, thereby helping to minimize the time spent at the customer's premises.

Preassembling the MDF and IDF, would be especially advantageous for those cases where the MDF or IDF, must be placed in an area that is awkward for this type of work.

### 230.3 SITE LIMITATIONS

Installation of a telephone system is seldom a straightforward routine procedure. The uniqueness of each customer's situation requires a tailored approach to each job. In selecting a permanent site for the MDF, the installer may encounter problems such as the following.

1. Limited space is available and must be used regardless of its suitability.
2. The available space may be adequate but may pose one or more environmental hazards.
3. The proposed location has limitations, such as, insufficient lighting, or the lack of a suitable ground, for grounding the KSU.

Whatever the nature of the adversities encountered, the installer must make the necessary decisions to arrive at the best possible solutions for both the customer and the equipment being installed. It is beyond the scope of this manual to cover all possible

situations with specific solutions. The following are general guidelines, precautions and necessities, which should be observed when making the decisions for an installation.

It should be noted that there are certain specific requirements and precautions which, if not followed, will impair the reliability of the system.

### 230.4 SITE SELECTION CONDITIONS

The following conditions should be met at the site chosen for mounting the Key Service Unit (KSU).

1. The KSU is normally wall mounted, to protect against accident or flooding. Use of a 3/4" plywood backboard is recommended for this purpose.
2. The KSU should not be located directly beneath pipes, due to the possibility of leaks or condensation causing damage to the Electra 8/24 Key Telephone System equipment.
3. The area in which the KSU is to be located must be free of corrosive and inflammable gases, excessive chemical or industrial dusts, and other materials which could cause a hazard to personnel or to the proper functioning of the equipment.
4. Heat and humidity must be within the limits provided in paragraph 220.11, of this manual.
5. Although its virtually noiseless operation allows a wide selection of installation sites, care should be taken that the KSU does not present a hazard to office traffic. For purposes of economy, a central location to minimize cabling, is often used.
6. The KSU is designed to be mounted vertically. Failure to mount the KSU vertically may cause excessive heat build up in the KSU and intermittent relay operation.

### 230.5 MDF CONSTRUCTION

The Main Distribution Frame (MDF) consists of two different types of standard quick-connect terminal blocks, which are to be mounted onto the 3/4" plywood backboard. For the sake of neatness and ease of access, it is also recommended that the blocks be mounted on appropriate standoffs. The recommended block is the 66M50 type, for termination of the station cables. Refer to Figure 200-4 for a suggested MDF layout.

Both the MDF and the IDF utilize standard bridging clips for each type terminal block. The bridging clips are used to mate the left half of the terminal block (terminated cable run) to the right half of the terminal block (cross connection wire).

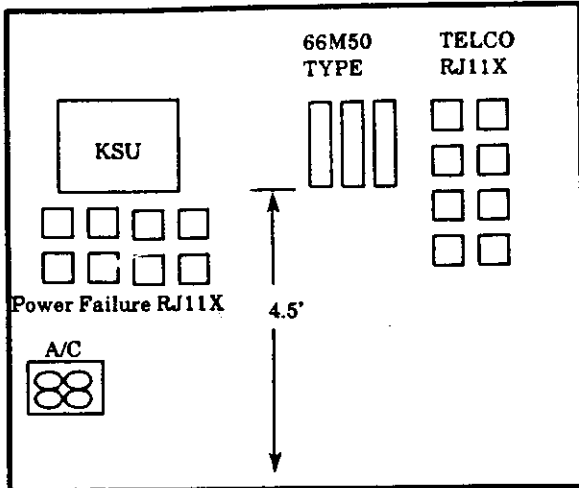


Figure 200-4 Typical MDF Layout

### 230.6 KSU CABLES

Each KSU can be equipped with three 50 pin, female amphenol type connectors. These connectors are designated J1, J2, and J3. Refer to section 240, of this manual, for KSU wall and floor mounting instructions.

### 230.7 OUTSIDE LINES

1. The FCC authorized connector for the connection of CO lines, is an RJ11X. The lines must be connected in the appearance order best suited to the customer's usage.

2. Table 200-19 provides complete information about the 50 position connector, showing pin number, lead function, running cable color, station cable color, port and circuit designation.

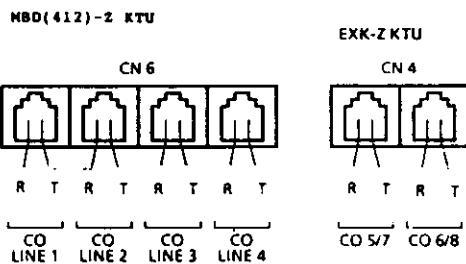


Figure 200-5 CO/PBX Line Connection

3. **HALF-TAPPING or PARALLEL CONNECTIONS** must not be used on outside lines connected to the Electra 8/24 Key Telephone System. This practice generally results in system malfunctions on the outside lines.

4. Power Failure Transfer can be provided for all CO/PBX lines, with the PFT-Z KTU installed (max.4).

To provide Power Failure Transfer for lines 1-4, two PFT-Z KTUs must be installed in connectors CN15 and CN16 on the MBD(412)-Z KTU, on lines 5 & 6, a PFT-Z KTU must be installed in connector CN6 of the first expansion KTU, lines 7 & 8 would require a PFT-Z KTU installed in connector CN6 of the second expansion KTU.

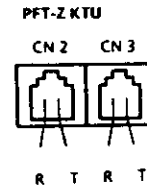


Figure 200-6 PFT-Z KTU Single Line Telephone Terminal Connector

Refer to Table 200-16 for PFT-Z and MBD(412)-Z Power Failure Transfer connectors.

Table 200-16 Power Failure Connector Identification

KTU	LINES	KTU Connectors	PFT-Z Connectors
MBD(412)-Z (Main Board)	1	CN15	CN2
	2	CN15	CN3
	3	CN16	CN2
	4	CN16	CN3
1st Expansion KTU (EXK-Z)	5	CN6	CN2
	6	CN6	CN3
2nd Expansion KTU (EXK-Z)	7	CN6	CN2
	8	CN6	CN3

### 230.8 STATION EQUIPMENT

1. When connecting Key Telephones to the MDF or IDF, individually twisted two pair cabling is required.

Refer to section 220, of this manual, for specifications, Table 200-17, for lead identifications, Figure 200-7 for DSS/BLF modular jack (RJ11C/W) connection, Figure 200-8 for Key Telephone modular jack (RJ13C/W) connection.

2. When SLTs are installed in the system to operate as *Power Failure Transfer* telephones, connection on the PFT-Z KTU is necessary.

One pair cabling is required; it is recommended that twisted pair cabling be used.

The SLTs must match the outside line type for proper power fail operation. DTMF for tone dialing and rotary for Dial Pulse signaling.

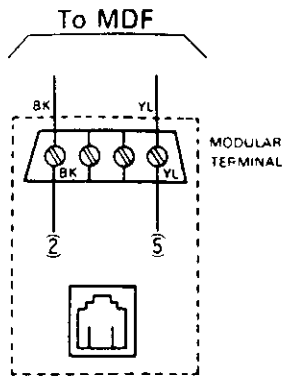


Figure 200-7 View of Modular Terminal for Connection of a DSS/BLF Console

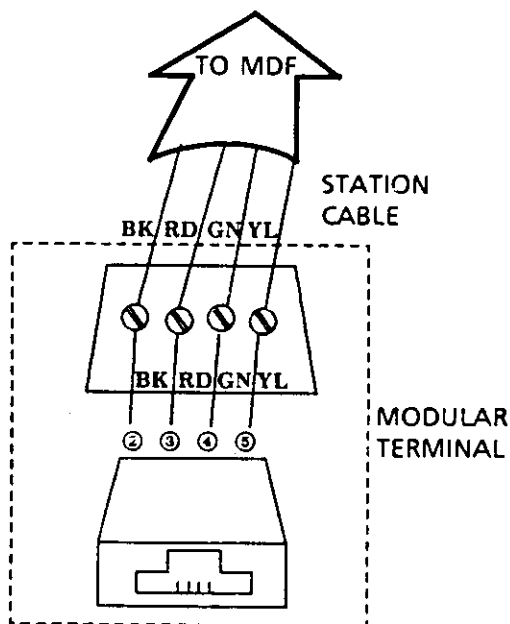


Figure 200-8 View of Modular Terminal for Connection of Key Telephone

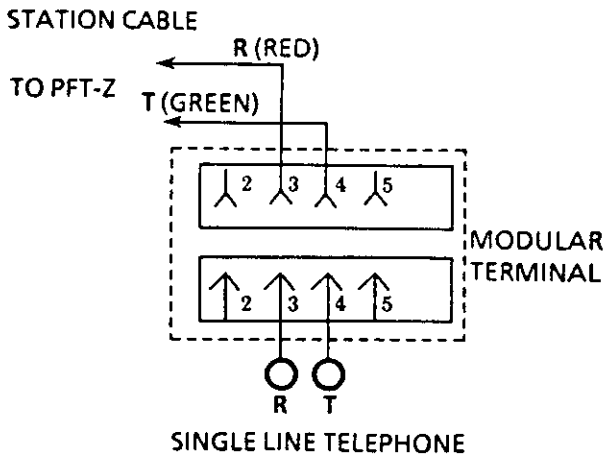


Figure 200-9 Simplified Schematic - Single Line Telephone Connection for Power Failure

## SECTION 240 KEY SERVICE UNIT (KSU) CONNECTION

**CAUTION:** Do not connect the KSU power supply line cord to the AC outlet until the wall, or floor mounting procedure is complete.

### 240.1 OPENING THE KSU COVER

1. Remove two screws.

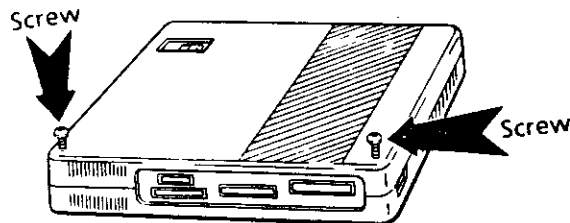


Figure 200-10 KSU cover screws

2. Slightly lift the bottom end of the cover.

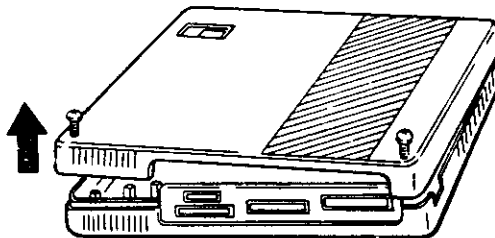


Figure 200-11 Opening KSU cover

3. Push the cover upward until it comes off.

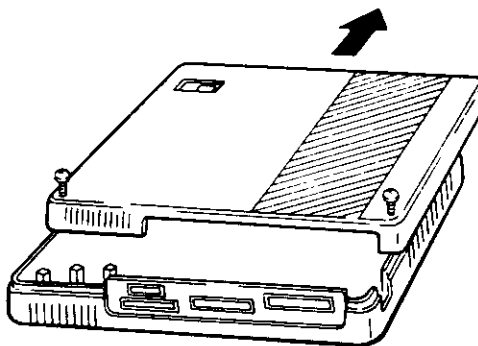


Figure 200-12 Removing KSU cover

### 240.2 WALL MOUNTING THE KSU

To secure the KSU onto the wall, fasten it by using the supplied template and mounting screws (locally provided) as shown. Use of a sheet of fire retardant 3/4" plywood for the MDF is recommended. First mount the plywood to a secure wall, then:

1. Tape the template to the MDF and fasten it with the four mounting screws approximately 7/16" or halfway (locally provided).

**Table 200-17 Connection Information / Connector and Port Relationship**

PIN	RUNNING CABLE	STATION CABLE	LEAD FUNCTIONS	MBD(412)-Z	EXK-Z	EXK-Z
			KEY TELEPHONE DSS/BLF	J1	J2	J3
				PORT	PORT	PORT
26 1 27 2	WH-BL BL-WH WH-OR OR-WH	GN RD BK YL	VT VR DT DR	10	22	28
28 3 29 4	WH-GN GN-WH WH-BR BR-WH	GN RD BK YL	VT VR DT DR	11	23	29
30 5 31 6	WH-SL SL-WH RD-BL BL-RD	GN RD BK YL	VT VR DT DR	12	24	30
32 7 33 8	RD-OR OR-RD RD-GN GN-RD	GN RD BK YL	VR VT DT DR	13	25	31
34 9 35 10	RD-BR BR-RD RD-SL SL-RD	GN RD BK YL	VA VR DT DR	14	26	32
36 11 37 12	BK-BL BL-BK BK-OR OR-BK	GN RD BK YL	VT VR DT DR	15	27	33
38 13 39 14	BK-GN GN-BK BK-BR BR-BK	GN RD BK YL	VT VR DT DR	16	N/C	N/C
40 15 41 16	BK-SL SL-BK YL-BL BL-YL	GN RD BK YL	VT VR DT DR	17	N/C	N/C
42 17 43 18	YL-OR OR-YL YL-GN GN-YL	GN RD BK YL	VT VR DT DR	18	N/C	N/C
44 19 45 20	YL-BR BR-YL YL-SL SL-YL	GN RD BK YL	VT VR DT DR	19	N/C	N/C
46 21 47 22	VI-BL BL-VI VI-OR OR-VI	GN RD BK YL	VT VR DT DR	20	N/C	N/C
48 23 49 24	VI-GN GN-VI VI-BR BR-VI	GN RD BK YL	VT VR DT DR	21	N/C	N/C

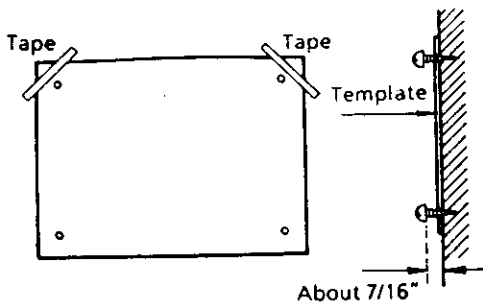


Figure 200-13 Wall Mounting the KSU

2. Hold the KSU against the wall with the holes in line with the screws on the MDF, pull the KSU down to properly seat it and tighten the screws.

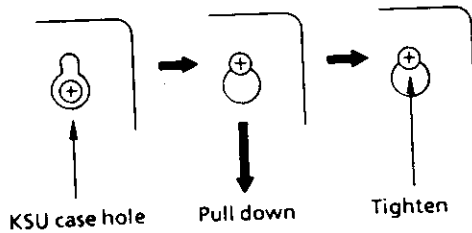
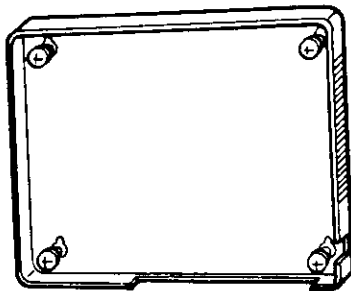


Figure 200-14 Mounting screw locations

3. Hook the KSU cover with the tabs on top of the base, and tighten the two screws.

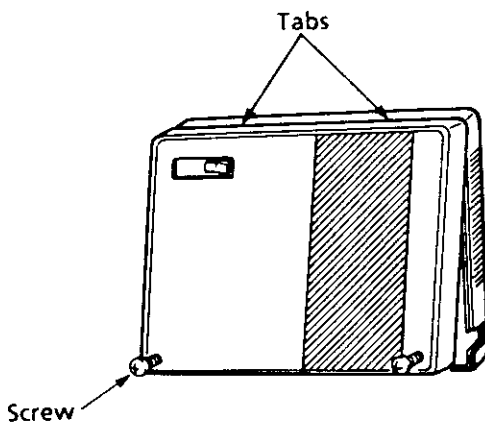


Figure 200-15 Replacing the KSU cover

### 240.3 FLOOR MOUNTING THE KSU

To mount the KSU on the floor (when wall mounting is impossible), use the optional FMU-Z mounting unit.

1. Assembly of the floor mount bracket is required. Attach the base plate to the vertical bracket using the four screws provided. Insert the screws from the bottom as shown in Figure 200-17.
2. Implant two 6.5 mm (approximately 9/32") anchor bolts (locally provided) into the floor.

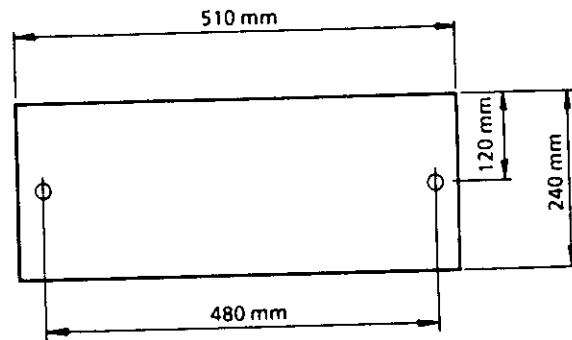


Figure 200-16 Floor Mounting the KSU

3. Fasten the FMU-Z unit to the floor with the 6.5 mm anchors and loosen the four KSU mounting screws.

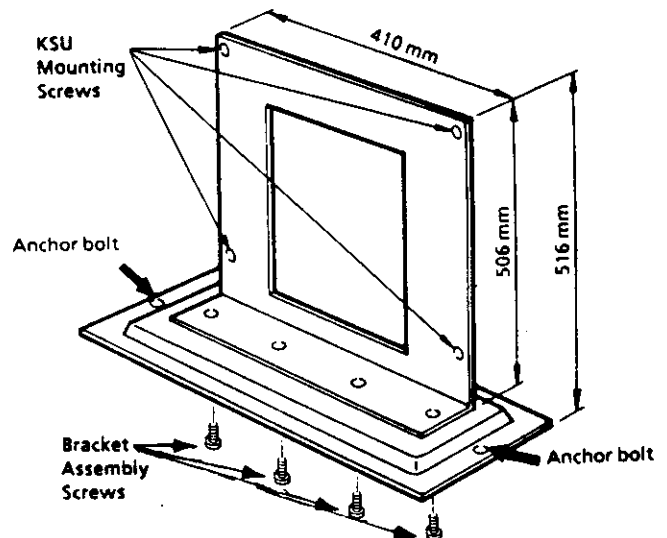


Figure 200-17 Floor mounting unit (FMU-Z)



4. To open the KSU cover:

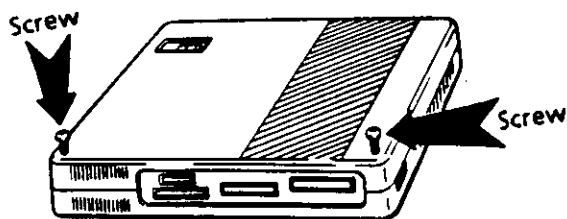


Figure 200-18 KSU cover screws

- a. Remove two screws.
- b. Slightly lift the bottom end of the cover.

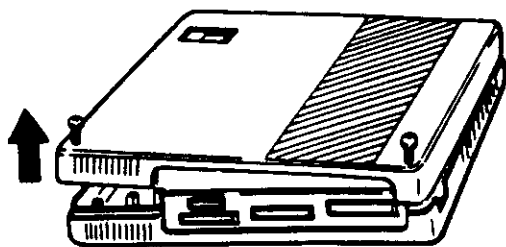


Figure 200-19 Opening KSU cover

- c. Push the cover upward till it comes off.

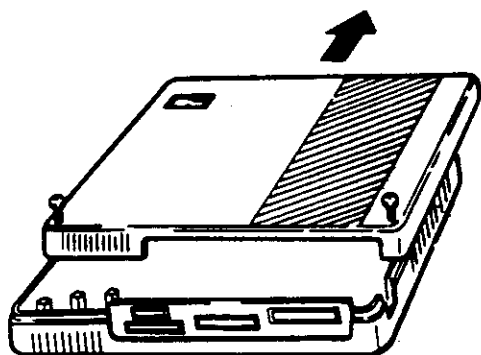


Figure 200-20 Removing KSU cover

5. Hold the KSU base against the floor mounting unit with the mounting holes in line with the screws, and tighten the screws securely from inside the KSU.

6. Hook the KSU cover with the tabs on top of the base, and tighten the two screws.

#### 240.4 KTU INSTALLATION NOTES

1. Power must be OFF during installation and maintenance to prevent accidental damage to equipment.

2. The KTUs used in this system make extensive use of CMOS technology. Extreme care must be taken to avoid static discharge when handling KTUs.

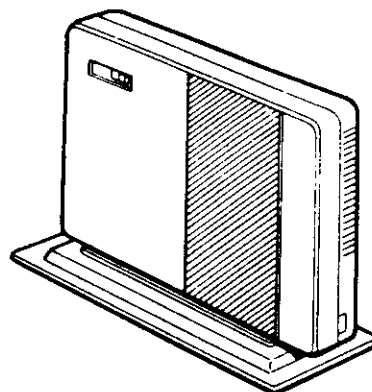


Figure 200-21 Closed, Mounted KSU

#### 240.5 MOUNTING the KTUs

1. Be sure to mount the KTUs in their correct positions of the Key Service Unit.

Make any connections and switch settings, on the KTUs, prior to mounting them in the KSU.

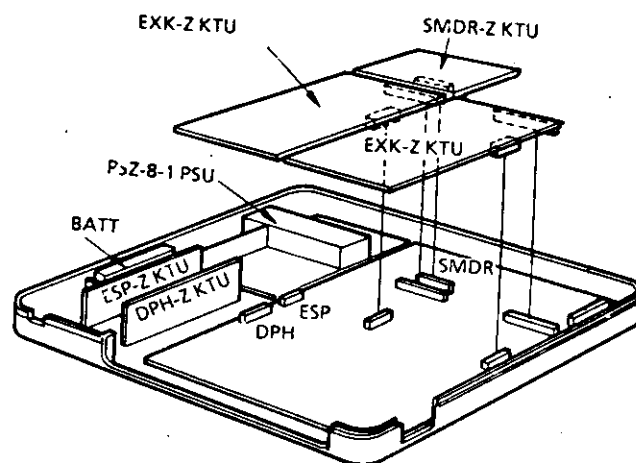


Figure 200-22 KTU Positions

2. Mounting the ESP-Z and DPH-Z Units

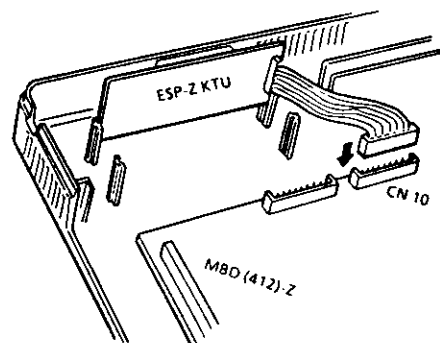


Figure 200-23 ESP-Z KTU connection

Insert the KTUs into the specified positions in the guide rails and connect them to the connectors on MBD-Z KTU.

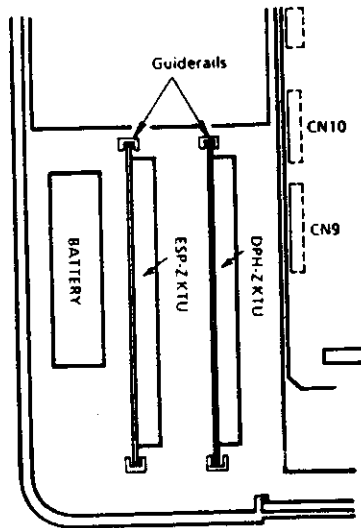


Figure 200-24 MBD-Z KTU guide rails location

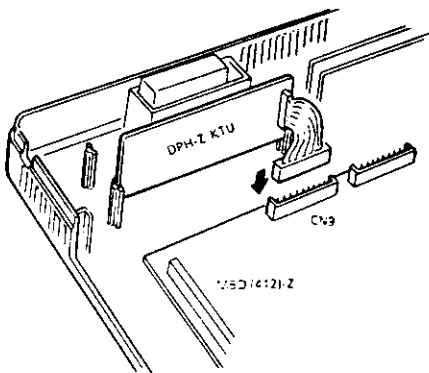


Figure 200-25 DPH-Z KTU connection

#### 240.6 CONNECTION of the J CONNECTORS

When an printer, EXK-Z, and SMDR-Z KTUs are mounted in the KSU, the connector plate located in the lower part of the KSU, will require the installer to remove the appropriate KNOCK OUTS.

1. Remove the KNOCK OUTS on the connector plate.
2. Insert the connector into the slot to be used and fasten the connector with screws provided.

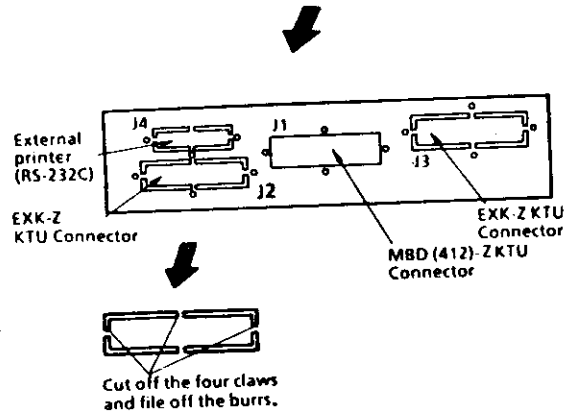
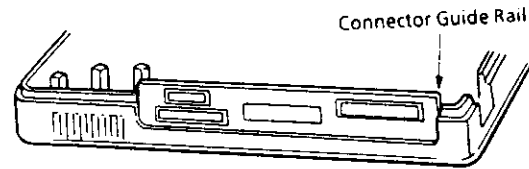


Figure 200-26 Mounting the J cable connectors

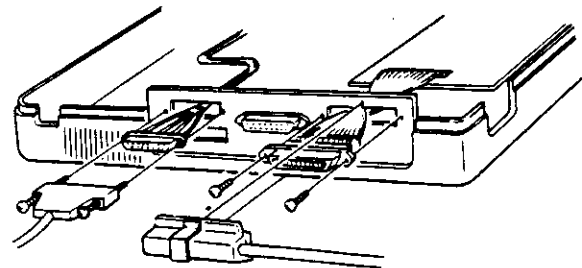


Figure 200-27 Fastening the J cable connectors using tie wraps provided

#### 240.7 CABLING ROUTE in the KSU

Form, and fasten, the cable to be connected to each unit; CO/PBX lines, Key Telephones, Power Failure Single Line Telephones, Facsimile, SMDR printer, etc.

#### 240.8 COMMON CONTROL KTU

The MBD(412)-Z KTU controls the system as a whole, and is provided in the Key Service Unit. This KTU provides the switch matrix which controls speech path switching, *Music On Hold*, *Memory Backup Battery*, CO/PBX interface which controls 4 CO/PBX lines, a facsimile, and a telephone interface which controls 12 Key Telephones.

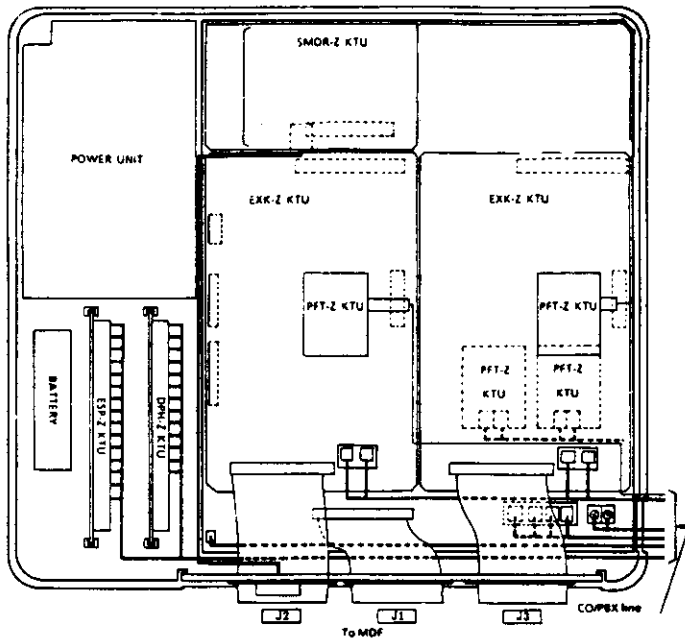


Figure 200-28 Cabling Route in the KSU

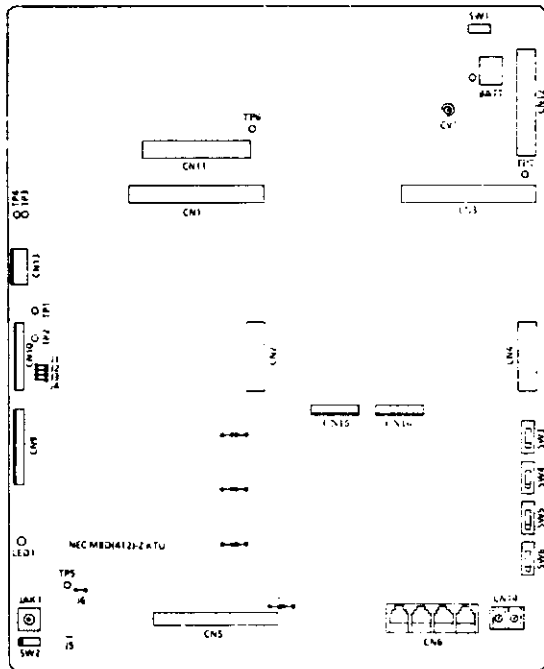


Figure 200-29 MBD(412)-Z KTU Switch and connector layout

1. For MF or KF selection  
Cut J4 jumper wire when system is registered as MF (Refer to Figure 200-29 for jumper location).
2. Memory backup  
Switch SW1 is used for protecting the contents of the system memory, during a commercial power failure which occurs for longer than the 10 minute

system *Battery Backup*. Ensure this switch is always in the ON position.

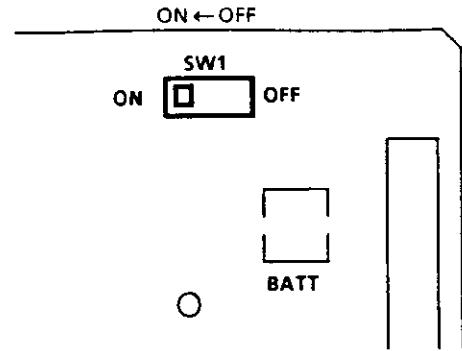


Figure 200-30 Memory Backup Switch

3. Music on Hold tune selection  
Either of the two melodies, provided on the MBD(412)-Z KTU, can be selected by changing the setting of switch SW2. When SW2 is set to the left, the tune *Green Sleeves* is selected and to the right, *Two Minuets*.

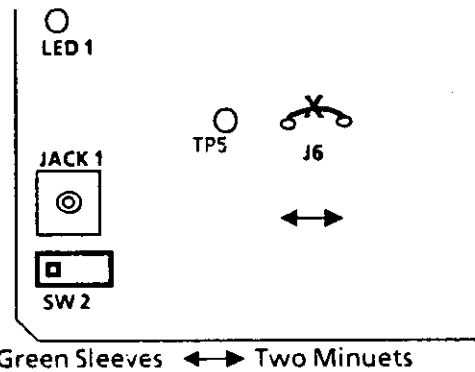


Figure 200-31

4. External hold tone volume selection.  
The volume of external hold tone can be increased by cutting the J6 jumper wire.
5. Station busy indication.  
LED 1 on the MBD(412)-Z KTU lights when any of the telephones are in use.
6. CO/PBX pad control.

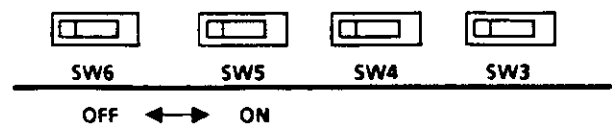


Figure 200-32 Pad Control

Set switches SW3-SW6 to the ON position when a -3dB pad is required. These are factory set without a -3dB pad.

CO/PBX line 1 is controlled by SW3, line 2 by SW4, line 3 by SW5, and line 4 by SW6.

7. Facsimile

When using a facsimile, connect it to screw terminal connector CN14 on the MBD(412)-Z KTU as shown in Figure 200-33.

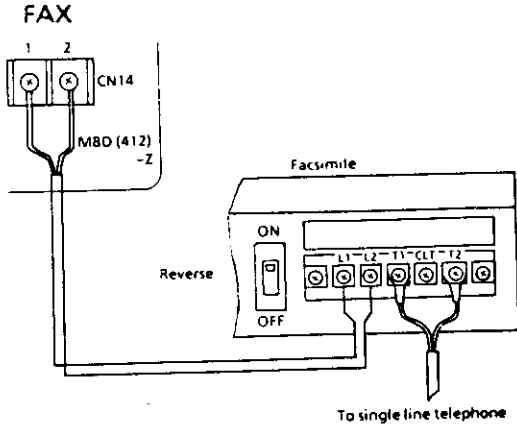


Figure 200-33 Connector CN14

- a. The facsimile is connected to the CO/PBX side. Set the reverse switch, on the facsimile, to the ON position, when polarity reversal is required by the facsimile.
- b. The facsimile works in conjunction with CO/PBX line 4.

8. External Music on Hold source

When a Music on Hold source, other than the internally provided tunes, is to be used; connect the source to JACK 1 on the MBD(412)-Z KTU as shown in Figure 200-34.

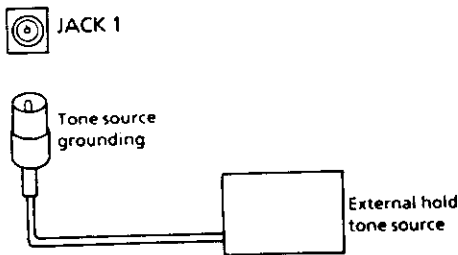


Figure 200-34 Connector JACK 1 location

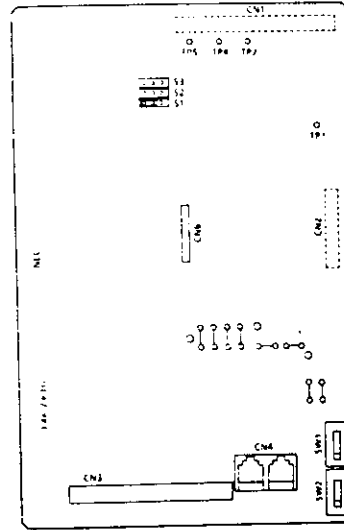


Figure 200-35 EXK-Z KTU Switch and Connector Layout

- a. CO/PBX line pad control  
 Set switches SW1 and SW2 to the ON position when -3dB pad is required (OFF=0dB).
- b. CO/PBX line 1 is controlled by SW1 and CO/PBX line 2 by SW2.

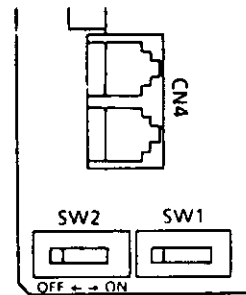


Figure 200-36 EXK-Z KTU Switch Location

2. DPH-Z KTU

This KTU is used when installing a Door Phone(s) in a system. The DPH-Z KTU allows connection of up to 2 Door Phones, when one

Door Phone is in use the other cannot be used. The unit can also control a door lock release and external sensors (security system).

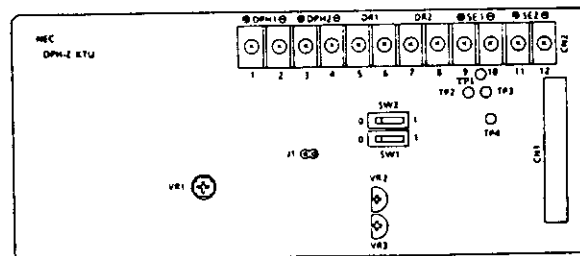


Figure 200-37 DPH-Z KTU Switch and Connector Layout

240.9 INTERFACE KTUs

1. EXK-Z KTU

This unit provides additional accommodations of 2 CO/PBX and 6 Key Telephone ports.

The unit consists of an interface that controls 2 CO/PBX lines, an interface that controls 6 Key Telephones (DSS/BLF Consoles), and a switch matrix that controls speech path switching for the 2 CO/PBX lines and 6 Key Telephones.

- a. **Speech volume control**  
VR1 and VR2 are factory adjusted for the speech volume between a station and *Door Phone*. (DO NOT ADJUST)
- b. **Ring tone volume control**  
VR3 is for adjusting the ringing tone volume from the *Door Phone*.

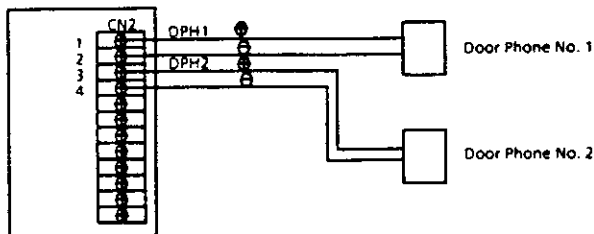


Figure 200-38 Door Phone Connection

- c. **Door Phone**  
**NOTE:** When connecting *Door Phones*, program the *Door Phones* to be installed in system data, memory block 1-31.
- d. **Door lock release**  
When this feature is required, additional locally provided door control equipment is needed. Refer to Figure 200-39. When using the door lock release circuits, they must be enabled in system data (Memory Block 1-32).

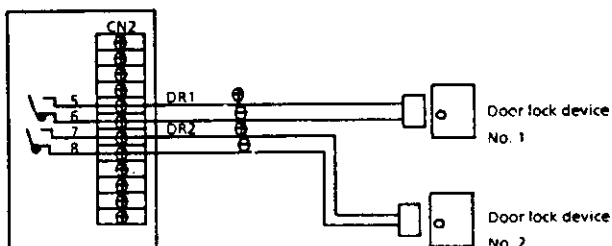


Figure 200-39 Door Lock Release Connection

- e. **Sensor**  
Sending an alarm to an idle Key Telephone is done by operating an emergency control circuit.

- **Make-start**  
Set switch SW1 to the 0 position, when controlling sensor No. 1 needs a make-start signal; set SW2 to the 0 position, when controlling sensor No. 2 needs a make-start signal. Refer to Figure 200-40.
- **Break-start**  
When the sensor is installed on a window etc., where current is always present, an alarm is sent to all idle Key Telephones when the current is removed;

Set switch SW1 to the 1 position when controlling sensor No. 1 needs a break-start

signal; set SW2 to the 1 position when controlling sensor No. 2 needs a break-start signal.

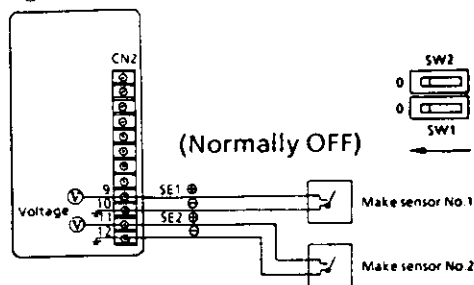


Figure 200-40 Security Sensor Connection

### 3. ESP-Z KTU

This KTU is required when installing an external page speaker(s) (up to 2) in a system.

This KTU can also control external and internal BGM, an external amplifier and/or external relay.

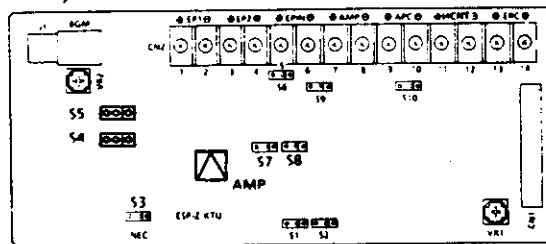


Figure 200-41 ESP-Z KTU Switch and Connector Layout

- a. **External speaker volume control**  
To increase the external speaker volume, adjust VR1 clockwise.
- b. **Station BGM volume control**  
To increase the station BGM volume, adjust VR2 clockwise.
- c. **External speaker**  
When an external speaker call is made using the built-in amplifier, the impedance of the speakers can be either 600 or 8 ohms.

Move the jumper position of S1, S3, S4, and S5 to match the impedance of the external speaker connected, as shown on Table 200-20.

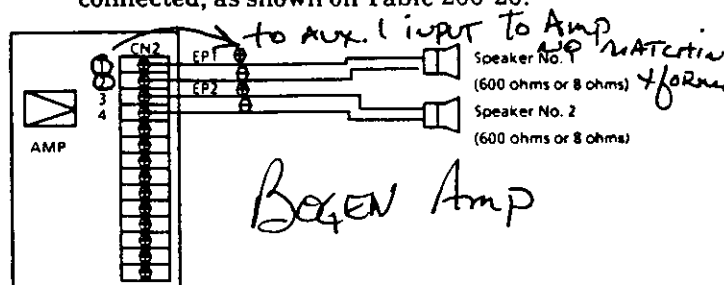


Figure 200-42 External Speaker, with use of the internal Amplifier, connection

d. External music source

When connecting an external music source, for BGM, to external speakers, use the connection provided in Figure 200-43. An external paging call will interrupt the BGM only to the zone paged and only during the page announcement.

Move the jumper position of S1, S7, and S8 to meet the needs of an external sound source connection, as shown on Table 200-18.

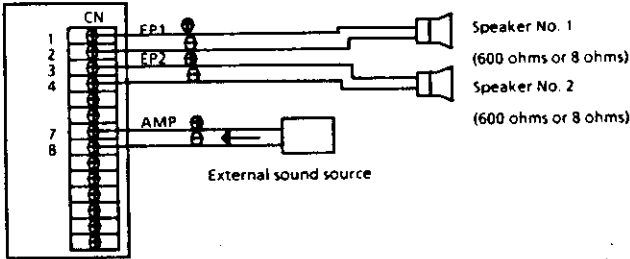


Figure 200-43 External Music Source Connection

e. External amplifier

Connecting an external amplifier, when the built-in 2 Watt amplifier output is not enough, is possible with this KTU. Match the impedance of external speakers according to the specification of the external amplifier.

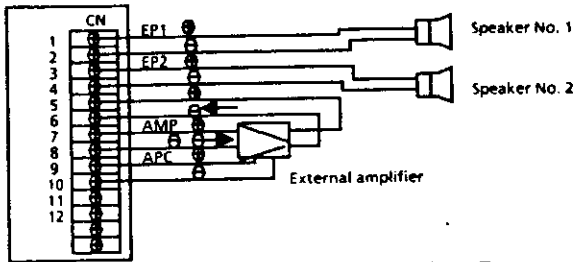


Figure 200-44 External Paging System Connection

If a current capacity larger than the rating of the internal relay is required, control the external amplifier via an external relay.

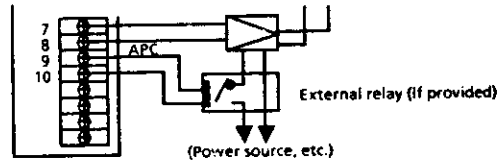


Figure 200-45 External Paging Amplifier Relay Control Connection

*Low level TO AMPL. SPE OR AMPLIFIER*  
*takes more to DRIVE*

Table 200-18 Switching for External Devices via CN2

Pin Jumper Number	Connected Device Name						
	External Speaker (terminals 1,2,3, & 4)		External BGM Source (terminals 7 & 8)	External Amplifier (terminals 9 & 10)		External Music On Hold Source (terminals 11 & 12)	
	600Ω	8Ω		Make Start	12V Start	Make Start	12V Start
S1	1-2	1-2	1-2	2-3	2-3	-	-
S2	-	-	-	1-2	1-2	-	-
S3	1-2	2-3	-	-	-	-	-
S4	1-2	2-3	-	-	-	-	-
S5	1-2	2-3	-	-	-	-	-
S6	-	-	-	2-3	2-3	-	-
S7	-	-	1-2	2-3	2-3	-	-
S8	-	-	1-2	2-3	2-3	-	-
S9	-	-	-	1-2	2-3	-	-
S10	-	-	-	-	-	1-2	2-3

Notes: 1. When connecting pins 1-2 with the jumper:



When connecting pins 2-3 with the jumper:



2. Set jumpers prior to installation of EXK-Z KTUs.

f. **External Music On Hold source**  
 An external Music On Hold source can be connected, as shown in Figure 200-46, and Figure 200-34.

Move the jumper position of **S10**, for external Music On Hold source connection as shown on Table 200-18.

Connection to terminals 11 and 12 (as shown) are only required if the Music source needs either a 12Volt or Make Start (Ground Start) control.

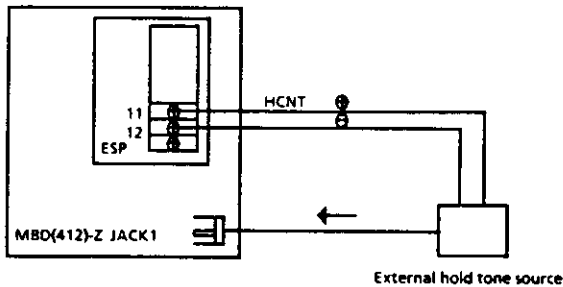


Figure 200-46 External Music On Hold Source Control

g. **Extension bell**  
 An external bell, for ringing during incoming CO/PBX calls, in noisy areas is connected to this KTU, as shown in Figure 200-47.

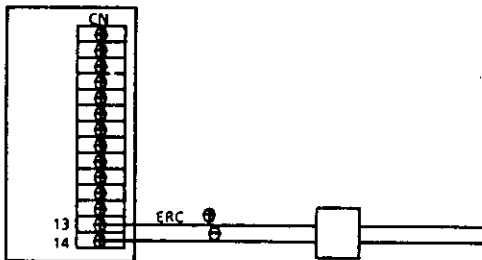


Figure 200-47 External CO/PBX Bell Connection

h. **Station BGM (sending)**  
 To send BGM through the speaker of the Key Telephone, a locally provided sound source must be connected to **J1**.

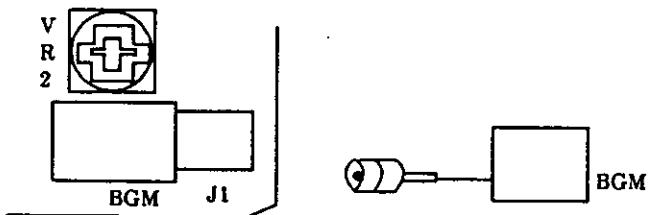


Figure 200-48 External Station BGM Connection

ON/OFF control is available at each Key Telephone.

Volume is adjustable with VR2, on a system wide basis.

5. **SMDR-Z KTU**  
 This KTU provides detailed call records of the systems CO/PBX calls. The KTU can output outgoing call information (called numbers, call times) to the printer, via its RS-232C connector.

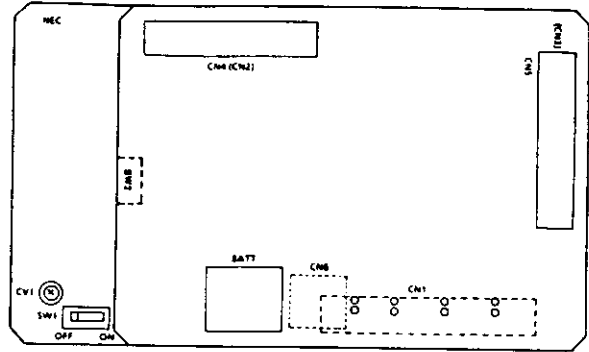


Figure 200-49 SMDR-Z KTU Switch and Connector Layout

1. Plug the larger SMDR-Z KTU into connector CN1 on the MBD(412)-Z.
2. Secure the larger SMDR-Z KTU with four screws provided.
3. Plug the smaller SMDR-Z KTU into connectors CN2 and CN3 located on the larger SMDR-Z KTU.

**NOTE:** The baud rate must be selected prior to step 3.

- a. **Memory backup**  
 Switch SW1 sets the battery backup to preserve the memory in which the call information is stored, during a system Power Failure. Ensure that SW1 is always in the ON position.
- b. **Baud rate selection**  
 The speed of data transfer to the external printer is set with switch SW2.

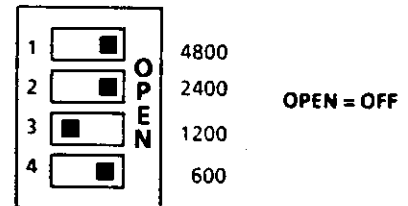


Figure 200-50 Switch SW2

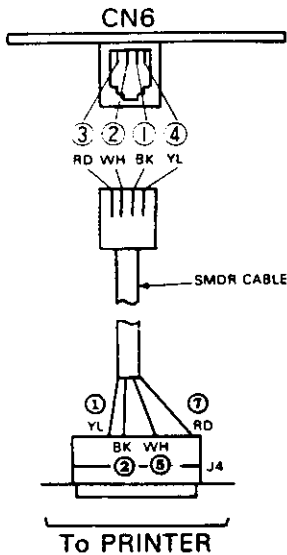
- c. **Printer specifications in Tables 200-19 and 200-20 are of the SMDR-Z KTU output.**

Table 200-19 RS-232C Connector Pin Configuration (J4)

PIN	DESCRIPTION
1	FG (Frame Ground)
2	TXD (Transmit Data)
5	CTS (Clear to Send)
7	SG (Signal Ground)

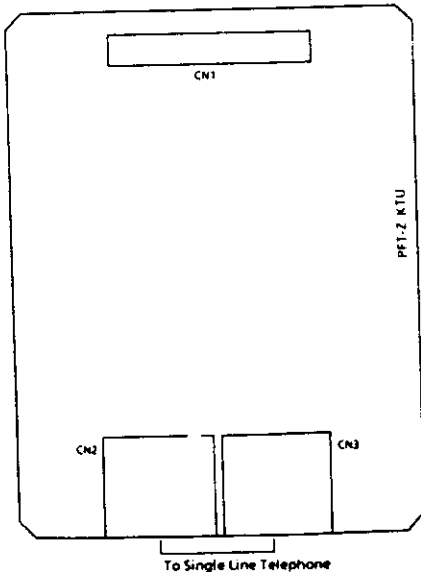
**Table 200-20 Interface Signal Specifications**

EIA RS-232C based:	
● Data:	8-bit ASCII code
● Parity bit:	Even
● Stop bit:	2 bits
● Baud rate:	600, 1200, 2400, 4800 bps
● Signals:	FG, TXD, CTS, SG
● Synchronization:	Asynchronous
● Maximum distance:	(15 meters) 50 feet



**Figure 200-51 RS-232C (J4) Cable**

6. **PFT-Z KTU**  
 This unit automatically connects a Single Line Telephone to a CO line during a Power Failure (after the system *Backup Battery* runs out), to enable conversation and ensure contact outside the affected Power Failure area. One KTU can connect 2 SLTs, each to a CO line. Up to 4 PFT-Z KTUs can be mounted in a system.

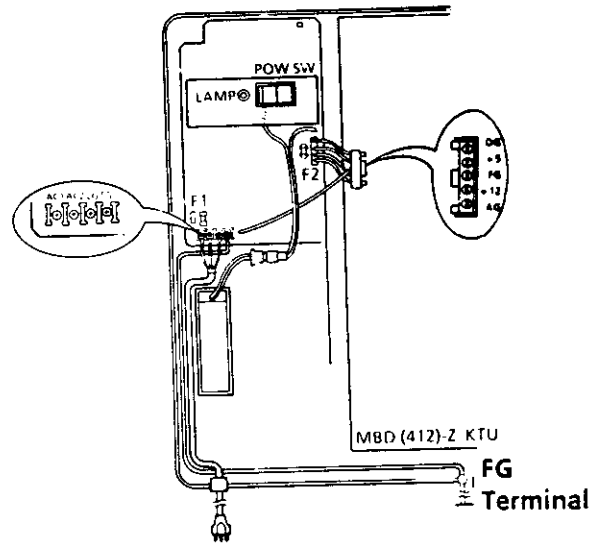


**Figure 200-52 PFT-Z KTU Connector Layout**

- Two different size sets of standoffs are included with the PFT-Z KTU. Each set contains 4 pieces. The set with taller standoffs is used only on the EXK-Z KTU when a PFT-Z KTU is required. The shorter set is used on the MBD(412)-Z KTU when PFT-Z KTUs are required.
- Switching of the device to be connected; Set jumpers S1-S4 to the 1-2 position. If any of the jumpers are not set to the 1-2 position, a Single Line Telephone will not be connected to a CO line.

## SECTION 250 POWER SUPPLY INSTALLATION

- The system power unit, PSZ-8-1, is mounted in the KSU. A battery that will backup full system operation for 10 minutes is also mounted.
- The connector from the PSZ-8-1 unit to the battery is not connected at the time of shipment. Figure 200-53 shows the location for these connections.



**Figure 200-53 PSZ-8-1 Connections**

Avoid connection of the KTU to a receptacle or grounding wire used in common with a computer, telex, etc.

## SECTION 260 ANCILLARY DEVICE CONNECTION

- 260.1 **GENERAL INFORMATION**  
 The ETZ-16D-1 Key Telephone can be equipped with devices such as the HFU-Z and ADA-Z Units.



### 260.2 HANDSFREE UNIT (HFU-Z)

The optional HFU-Z unit is required to enable an ETZ-16D-1 Key Telephone to have handsfree operation on both internal and CO/PBX calls.

1. Remove the access cover, located on the bottom of the Key Telephone, by lifting the edge on the side where the handset jack is located and then sliding it to the right, as shown in Figure 200-54.
2. Install the HFU-Z unit onto connector CN7 inside the telephone access area.
3. To replace the access cover, slide it to the left until it snaps into place.

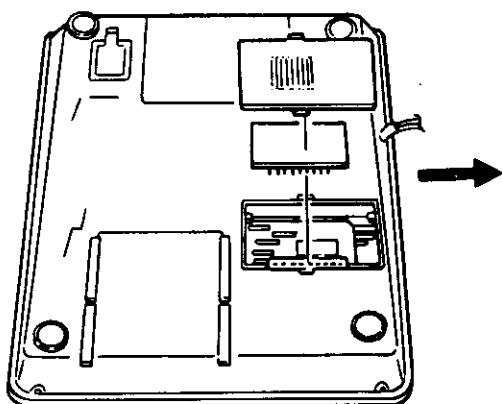


Figure 200-54 Mounting the HFU-Z Unit

### 260.3 ANCILLARY DEVICE ADAPTOR UNIT (ADA-Z)

The optional ADA-Z unit is required to connect such locally provided items as a jackset for a headset, or an external speakerphone to the ETZ-16D-1 Key Telephone.

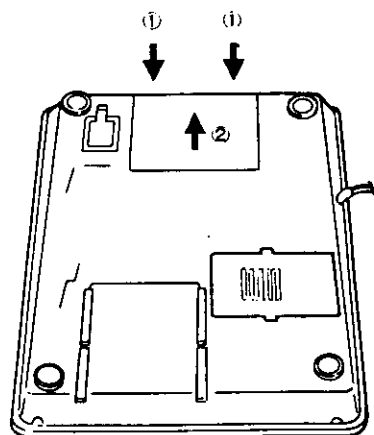


Figure 200-55 ADA-Z Unit Installation

Connection of the ADA-Z unit: (See Figures 200-56 and 200-57)

- a. Unplug line and handset cords.

- b. Turn Key Telephone upside down and place it on a dry surface.
- c. Locate the access panel at the top of the keyset. Press in slightly on the rear surface, then lift up. (See Figure 200-55).
- d. Locate the connector labeled CN2 (HAND). Unplug this connector from the TMB unit (main circuit board) then plug it into the ADA-Z jack labeled CN3. Plug connector labeled CN2 from the ADA-Z into the jack labeled CN2 (HAND) on the TMB unit. Plug the connector labeled CN1 from the ADA-Z into the jack labeled CN8 ADA on the TMB unit.

Table 200-21 ADA-Z UNIT CABLE

TMB UNIT		ADA-Z UNIT	
FROM	TO	FROM	TO
HANDSET			CN3
	CN2	CN2	
	CN8	CN1	

- e. Connect external device using the information provided in ETIs.
- f. Mount ADA-Z unit into Key Telephone using screw provided with component side down. (See Figure 200-56).
- g. Remove knock-out in access panel to route cables.
- h. Reinstall access panel by hooking front edge into bottom housing, then snap the back into place.
- i. Plug in handset cord, then line cord.
- j. Test Key Telephone operation, then test external device operation.

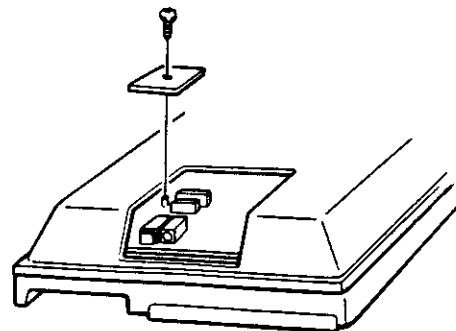


Figure 200-56 ADA-Z Unit Mounting Screw

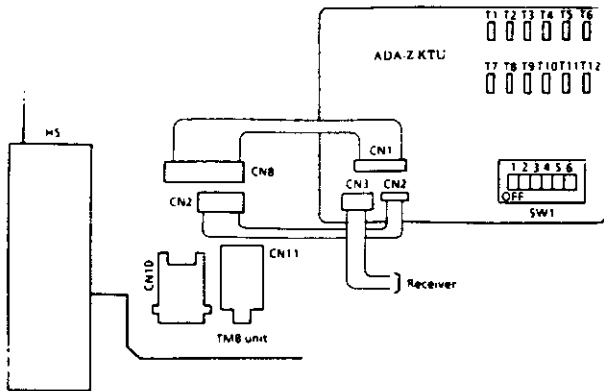


Figure 200-57 ADA-Z Unit Connection

**260.4 WALL MOUNT UNIT INSTALLATION**

An optional WMU-Z Key Telephone wall mounting unit is required when installing a Key Telephone onto a wall.

1. Remove the extension number plate and designation strip.
2. Remove the hanger by sliding it out, and remount it back in the original position upside down (with the projected side faced upward).
3. Reinstall the extension number plate and designation strip.

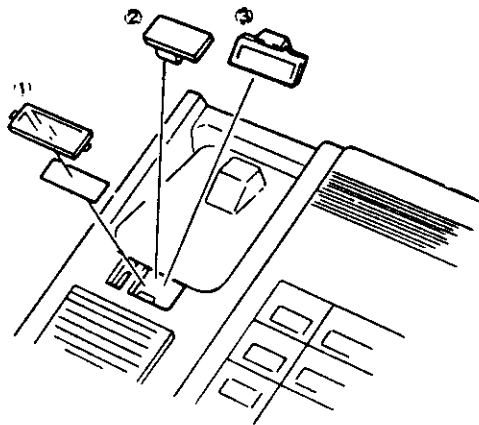


Figure 200-58 Wall Mounting Preparation

4. Fasten the optional wall mount unit (WMU-Z) to the wall, as shown in Figure 200-59.

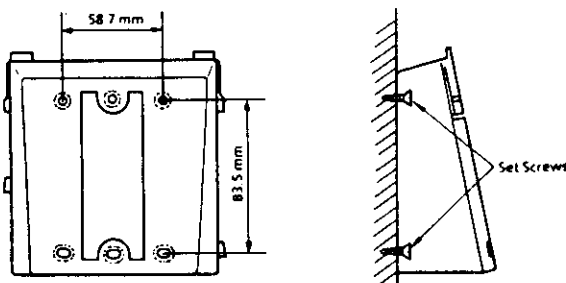


Figure 200-59 Setting The WMU-Z to the Wall

5. Mount the telephone onto the wall mounting unit by aligning the notches on the bottom of the Key Telephone with the rails on the wall mounting unit, as shown in Figure 200-60.

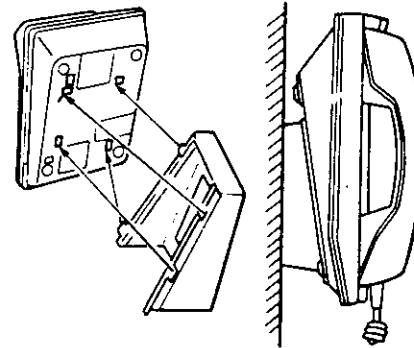


Figure 200-60 Mounting the Key Telephone to the WMU-Z

**260.5 CONNECTION of a DSS/BLF CONSOLE**

**NOTE:**The DSS/BLF Console cannot be connected to ports 10 or 11. Refer to Table 200-17 for DSS/BLF Console cable information, and Figure 200-8 for the modular terminal connection.

**260.6 CONNECTION of the DSS/BLF CONSOLE to an ETZ-16D-1 KEY TELEPHONE:**

1. Disconnect the DSS/BLF Console line cord and DC power connection.
2. Place the DSS/BLF Console face down on a clean dry surface, with the RJ11C connector to the top.
3. Insert the DSS/BLF Console connector bracket (with the tabs pointing up) into the two notches located on the right side of the DSS/BLF Console, secure it with the provided screw. Refer to Figure 200-61.
4. Disconnect the ETZ-16D-1 Key Telephone line cord from the RJ11C located on the bottom of the Key Telephone.
5. Place the Key Telephone face down on a clean dry surface with the RJ11C connector to the top.
6. Insert the DSS/BLF Console connector bracket (with the tabs pointing up) into the two notches located on the left side of the Key Telephone, and secure it with the provided screw. Refer to Figure 200-61.

7. Plug in the line cord for the Key Telephone into the RJ11C located on the bottom of the Key Telephone.
8. Plug in the line cord for the DSS/BLF Console into the RJ11C located on the bottom of the DSS/BLF Console.
9. Plug in the DC power cord connector into the jack located on the bottom of the DSS/BLF Console. Refer to Figure 200-61.

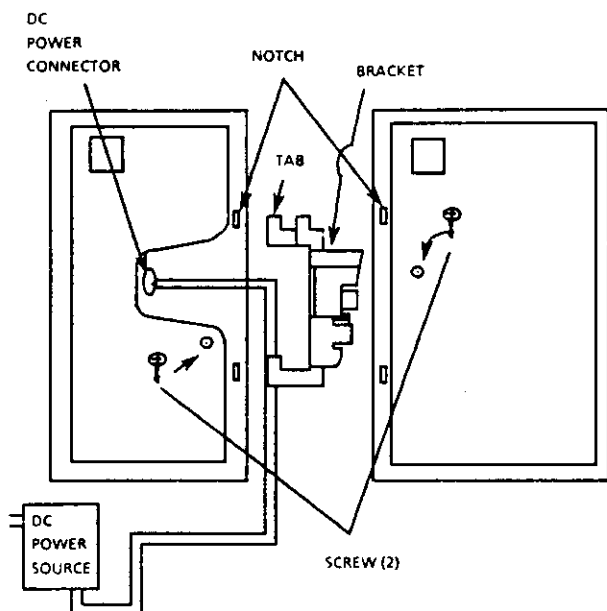


Figure 200-61 DSS/BLF Console Connection to an ETZ-16D-1 Key Telephone

10. Turn the attached two units right side up and test for proper operation.

### 260.7 CONNECTION of a RECORDING DEVICE and a MODEM

To record a conversation, a locally provided recording device such as a tape recorder can be connected to the ETZ-16D-1 Key Telephone. Data communication by connecting a locally provided modem is also available.

**CAUTION:** *The use of a monitoring device to eavesdrop or record telephone conversations may constitute an illegal invasion of privacy under some circumstances and laws. You should consult a legal advisor prior to implementing any practice involving recording of telephone calls.*

*FCC Order Docket #20940 permits the use of beep tone -OR- the consent of all parties when conversations are recorded. Sections 2510 to 2520 of the US Criminal Code (18U.S.C.2510 et seq.) provides stiff penalties for*

*unauthorized disclosure of wire or oral communications.*

Both a recording device and modem can be connected to a Key Telephone.

1. Remove the access cover; turn the Key Telephone upside down and place it on a dry surface. Press in on the back surface of the access panel slightly, then lift up.
2. Connect the mini-jack of the recording device to CN11 -or- connect the modular connector of the modem to CN10, as shown in Figure 200-62.
3. Remove the knock out(s) of the access cover and route the cable(s) through it.
4. Reinstall the access cover by hooking the front edge into the lower housing and snap it into place.

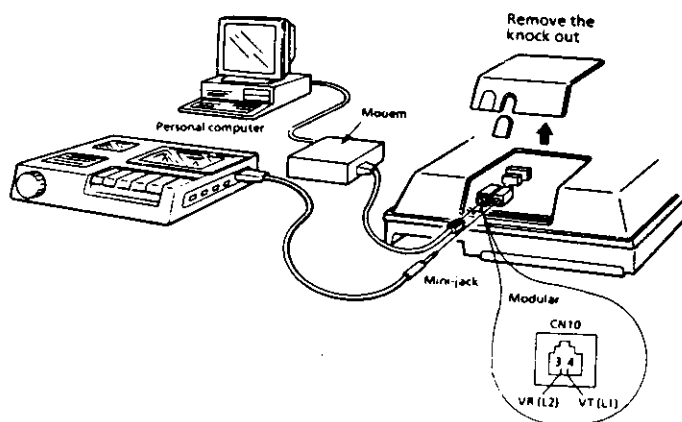


Figure 200-62 Bottom View of ETZ-16D-1 Key Telephone for Jack Locations



# **CHAPTER 3**

# **PROGRAMMING**



# CHAPTER 3 PROGRAMMING

## TABLE OF CONTENTS

SECTION	DESCRIPTION	PAGE	MEMORY BLOCK	FUNCTION	PAGE
310	General	300-2	34	SMDR Print Format	300-35
320	How to Use This Chapter	300-2	36	Intercom Master Number	300-36
325	System Initialization	300-3	37	CO/PBX Line On Hook Origination/Abandoning (Yes/No)	300-37
330	Resident System Default Values	300-4	42	Door Phone Call Automatic Answer (Allow/Deny)	300-38
340	System Programming Data Sheets	300-7	43	External Tone Ring Control	300-39
			44	Tandem Conference Line Assignment	300-40
			50	Automatic Release Disconnection Signal Detection Time	300-41
			51	1 + Dialing Assignment	300-42
			52	Toll Restriction Allow Table Size Assignment	300-43
			53	Digit Rejection Assignment	300-44
			54	OCC Override Table Assignment	300-45
			55	Toll Restriction Override Table Assignment	300-46
			<b>2 - Tenant Mode</b>		
			01	Tenant CO/PBX Line Accommodation	300-47
			<b>3 - CO/PBX Line Mode</b>		
			01 to 08	Seized Self CO/PBX Number Display	300-48
			09	CO/PBX Line Status Selection	300-49
			20	Automatic Release Selection	300-50
			<b>4 - Telephone Mode</b>		
			01	Telephone Status Selection - I	300-51
			02	Telephone Status Selection - II	300-52
			03	Extension Number Assignment	300-53
			04	Automatic CO/PBX Line Seizure/ Prime Line Assignment	300-54
			06	Ringling Tone Assignment	300-55
			<b>5 - Menu Selection Mode</b>		
			01	Feature Assignment	300-56
			02	Ringling Assignment- Day	300-61
			03	Ringling Assignment- Night	300-62
			04	Non/Toll/Outgoing Restriction	300-63
			<b>6 - Special Mode</b>		
			A	Speed Dialing Clear (System)	300-64
			B	Speed Dialing Clear (Telephone)	300-65
			C	ROM Version Confirmation	300-66
			350	Function Timer Chart	300-67
			360	Toll Restriction	300-68
			370	Job Specification Sheets	300-71

### 310 General

The Electra 8/24 Key Telephone System is a stored program controlled system. Upon initial power up, the system's ESZ-8-1 KSU CPU scans each of the possible interface units to determine the hardware configuration. The system stores this information as well as system default values into memory. *This area of memory is referred to as the Resident System Program.* After the initial power up, the Resident System Program can be changed so that the System can meet the particular needs of the customer. Job Specification sheets are provided in this chapter, these sheets help to organize each customer's programming needs and should be used and retained on the job site as well as in your office.

**NOTE:** Before attempting any programming of the Electra 8/24 Key Telephone System, it is important that the battery on the MBD(412)-Z KTU in the ESZ-8-1 KSU be checked to ensure SW1 is ON. Failure to do so will result in loss of system programming in the event of a commercial power outage and the system battery is no longer providing power to the system.

### 320 How to Use This Chapter

This chapter provides all the necessary information for programming the Electra 8/24 Key Telephone System. The chapter is divided into the following sections:

- 310 General
- 320 How To Use This Chapter
- 330 Resident System Default Values
- 340 System Programming Data Sheets
- 350 Function Timer Chart
- 360 Toll Restriction
- 370 Job Specifications Sheets

This **HOW TO USE CHAPTER** provides the reader directions and recommendations for using Chapter 3.

#### SYSTEM PROGRAMMING DATA SHEETS

Section 340 describes, in detail, each of the programming areas in the six memory blocks. This section is to be used as a guide when programming. For each programming area, Section 340 provides reference pages providing step by step instructions as well as all display messages, while programming. Charts and notes are also provided to help explain the program instructions; it also explains the use of each function and line key as it pertains to the particular program area.

#### FUNCTION TIMER CHART

Section 350 is provided as a quick reference for the system's timers, which can be set through programming. This section provides a full description of each timer, explaining their purpose and function

within the system as well as their default values, range, and the memory block area it is assigned.

#### CODE/CALL RESTRICTION

Section 360 discusses the code restriction plan designed into the Electra 8/24 Key Telephone System. Initially this section describes the Toll Restriction table and its general use when dialing restricted numbers. Discussion is then extended to the following dialing areas:

- A. 1 + dialing areas
- B. Direct Dialing areas
- C. OCC, Equal Access

A flow chart is included to provide the reader with a clearer, step by step, understanding of how the restrictions are handled, which is all the information needed to have a complete understanding of the Toll Restriction Plan. On the facing page a flow chart is provided and an explanation of the steps in the flow chart to further simplify the discussion.

#### JOB SPECIFICATION SHEETS

Section 370 contains the Job Specification sheets. These sheets contain all the system programming values and configurations required for an installation.

During the initial stages of system planning, the Job Specification sheets are necessary for collecting information to enable an accurate costing and installation of an Electra 8/24 Key Telephone System. The customer information, as collected by the salesperson (or installation supervisor), is recorded onto the Job Specification sheets. These sheets are presented in the logical order of the memory blocks (as provided in Section 340) to make the system programming as easy and efficient as possible.

The first group of sheets are used for entering the System Mode functions. The second group for assigning the Tenant Mode functions. The third group for programming the CO/PBX Line Mode functions. The fourth group for entering the Telephone Mode functions. The fifth for the Menu (Pattern) Selection Mode and the sixth for the Special Mode. This section is very useful for service technicians who need to keep track of adds, moves, changes, and in some cases for troubleshooting.

Each Job Specification sheet additionally includes a brief description sheet explaining the chart entries. These sheets must be kept up to date, and **LEFT ON THE JOB SITE**, to provide technicians with all the necessary information needed to provide the customer with proper, and professional service. A duplicate copy of the Job Spec sheets should also be maintained at the servicing office, in the customer's file for reference.



## FOLD OUT THE LAST PAGE OF THIS CHAPTER TO HELP GUIDE YOU THROUGH THE PROGRAMMING STEPS.

### ENTERING the PROGRAMMING MODE and the SELECTION of MEMORY BLOCKS

In order to use the sections just discussed, a brief description of how to enter the programming mode and the selection of memory block areas is necessary.

Initially, programming of the Resident System Program can be accomplished by either of two ETZ-16D-1 Key Telephones. These station positions are automatically assigned to the two lowest Key Telephone interface circuits on the MBD(412)-Z KTU in the system (ports 10 and 11).

The first step, when entering any area of programming, is to place the programming station into the OFF-LINE mode.

#### TO GO OFF-LINE

- A. The Programming Station must be idle
- B. Depress the FNC Key
- C. Depress the HOLD Key
- D. Dial \*,# in sequence

After these three steps, the display on the Key Telephone will show.

**OFF-LINE**

While the programming Key Telephone is OFF-LINE, it cannot be signaled by any station in the system, equally no other station is able to do system controlled station programming changes (i.e., Ring Assignment, Ring Tone or Off-hook). Only one programming Key Telephone can be off-line at one time.

The next step is to select the area in the system memory blocks which correspond to the feature, or function, to be programmed. A memory block index has been provided to help the programmer locate the area needed. Selection of a memory block location is done by depressing the Key Telephone's line keys in a predetermined sequence. The ETZ-16D-1 Key Telephone has eight Line Keys, LK1 through LK4, used to select memory block locations 1 to 4 respectively and Line Keys LK9 to LK12 are used to select memory block location 5. The Resident System Program is set up into six memory block areas, each of which is designated by a number to represent a function as follows:

1. System Mode
2. Tenant Mode
3. CO/PBX Line Mode
4. Telephone Mode
5. Menu (Pattern) Selection Mode
6. Special Mode

Memory blocks 1 through 4 can be accessed by depressing Line Keys 1 through 4, respectively. Memory block 5 can be accessed by depressing Line Keys 9 through 12. Memory block 6 can be accessed by depressing the FNC key, or CNF key.

	MEMORY BLOCK	KEY
Designation	1 through 4	Line Key 1 through 4
Designation	5	Line Key 9 through 12
Designation	6	FNC Key, CNF Key

	FUNCTION NUMBER	KEY
Designation	01-xx (Any number)	Dial Key 0 through 9

After selecting a memory block area, enter the function number using dial pad keys (0 to 9). (Memory blocks 5 & 6 do not have function numbers).

If the Menu Programming Feature assignment is needed, it must be programmed prior to other assignments.

To return to the main Memory Block areas (1 through 4) from the Menu Programming block, depress the appropriate line key (LK1 to LK4).

System Data Registration can be registered while telephones are in use. However, there are two types of data items. One is immediately updated upon registration operation, and the other is updated when all circuits in the system become idle.

The data items that will not be updated while telephones are in use are as follows:

Memory Block	Function
1-14	Station BGM Connection
1-17	DSS/BLF Console Assignment (when DSS number is changed)
1-21	DTMF Digit Duration
1-44	Tandem Conference Line Assignment

If any of the above data items are registered while a telephone is in use, the LCD will display

**DATA SET on idle**

without returning to the time display, even though the off-line mode is released, by depressing the SPKR key. When all circuits in the system become idle, the data is updated and the on-line mode is restored.

### 325 System Initialization

Two initialization procedures are provided:

A first initialization clears the resident program and returns it to its default values and returns the system to an idle condition. A second initialization is a

hardware reset which will return the entire system to an idle condition. The following are procedures for both types of initialization:

**First Initialization:**

- A. Go Off Line
- B. Depress the FNC Key
- C. Depress the RECALL Key
- D. Dial the digit 3
- E. Depress the HOLD Key
- F. Depress the MIC Key

**Second Initialization:**

- A. Go Off Line
- B. Depress the FNC Key
- C. Depress the HOLD Key
- D. Depress the LNR/SPD Key
- E. Dial the digits 1, 3
- F. Depress the RECALL Key
- G. Depress the MIC Key

**SECTION 330 RESIDENT SYSTEM DEFAULT VALUES**

MEMORY BLOCK	FUNCTION	DEFAULT VALUES
1-01	Hook Flash Time Selection	CO/PBX LINE: 0.6 sec.
1-02	Hold Recall Time Selection	2 minutes.
1-03	Paging Time Out Selection	90 sec.
1-05	Pause Time and Interdigit Time Selection	Pause Time: 3.5 sec. Interdigit Time: 800 msec.
1-07	Door Phone Display Time Selection	10 sec.
1-08	Ring Transfer Recall Time Selection	1 minutes.
1-09	Automatic Callback Time Selection	No limit
1-10	Automatic Redial Time Selection	Ringling Time: 60 sec. Waiting Time: 120 sec. Repeat 5 times.
1-12	Elapsed Call and SMDR Start Timer Selection	10 sec.
1-13	Intercom Call Signal Tone/Voice Selection	Voice
1-14	Station BGM Connection (Allow/Deny)	Deny
1-15	Cancellation of System Speed Dial Toll Override	No Cancellation
1-16	System Speed Dialing Confirmation Telephone	Port Numbers 10 and 11 only
1-17	DSS/BLF Console Assignment	DSS/BLF Console port numbers are assigned, if they are connected during system power up.
1-18	Ringling Tone Transfer	Allow
1-19	Time Display Switching (12h/24h)	12 Hour System
1-20	Off-Hook Ringing Tone (System Wide)	Allow
1-21	DTMF Digit Duration	100 msec.
1-23	Handset Receiving Volume	Down: The Volume increase is reset when you hang up.
1-24	Privacy Override Tone on CO/PBX Line (Allow/Deny)	Deny
1-25	External Speaker (Connected/Not Connected)	Connected
1-26	Line Selection Codes	Code 9: CO line Code 80: PBX, Code 88: —
1-27	PBX Access Code Assignment -I	8-(pause)
1-28	PBX Access Code Assignment -II	9-(pause)

**RESIDENT SYSTEM DEFAULT VALUES (Continued)**

MEMORY BLOCK	FUNCTION	DEFAULT VALUES
1-29	Privacy Override Assignment	NONE
1-30	Private Line Assignment	NONE
1-31	Door Phone Assignment (Installed/Not Installed)	Both Door Phones 1 and 2 installed
1-32	Door Lock Release (Allow/Deny)	Both relays Allowed
1-34	SMDR Print Format	All digits of dialed numbers
1-36	Intercom Master Number	No
1-37	CO/PBX Line On Hook Origination/Abandoning (Yes/No)	No
1-42	Door Phone Call Automatic Answer (Allow/Deny)	Deny
1-43	External Tone Ring Control	No
1-44	Tandem Conference Line Assignment	Port 21
1-50	Automatic Release Disconnection Signal Detection Time	150 msec.
1-51	1 + Dialing Assignment	1 + Area
1-52	Toll Restriction Allow Table Size Assignment	00 (All Deny Table)
1-53	Digit Rejection Assignment	NONE
1-54	OCC Override Table Assignment	NONE
1-55	Toll Restriction Override Table Assignment	NONE
2-01	Tenant CO/PBX Line Accommodation	Tenant 0 accommodates all CO lines
3-01 to 08	Seized Self CO/PBX Number Display	All clear (NONE)
3-09	CO/PBX Line Status Selection	<ul style="list-style-type: none"> <li>●CO/PBX Line Function: Origination &amp; answering</li> <li>●Polarity Reversal: No</li> <li>●CO/PBX Line: CO line</li> <li>●DP/DTMF Selection: DTMF</li> </ul>
3-20	Automatic Release Selection	Deny
4-01	Telephone Status Selection -I	<ul style="list-style-type: none"> <li>●Tenant Number: Tenant 0</li> <li>●Internal Page Group: Group 1</li> <li>●DSS/BLF dialing 0: DSS 1</li> </ul>
4-02	Telephone Status Selection -II	<ul style="list-style-type: none"> <li>●3-Minute Alarm: Deny</li> <li>●Off-Hook Ringing Tone: Port 10, 11 only</li> <li>●Prime Line Assignment: Deny</li> </ul>
4-03	Extension Number Assignment	10 - 33
4-04	Automatic CO/PBX Line Seizure/Prime Line Assignment	Allow
4-06	Ringling Tone Assignment	<ul style="list-style-type: none"> <li>●TEL Ringing Tone Variation: Low</li> <li>●Door Phone 1, 2 (Day, Night): Port 10 and 11 only ring on both Door Phone calls.</li> </ul>

**RESIDENT SYSTEM DEFAULT VALUES (Continued)**

<b>MEMORY BLOCK</b>	<b>FUNCTION</b>	<b>DEFAULT VALUES</b>
5-01	Feature Assignment	Pattern No. 000
5-02	Ringing Assignment -Day	Port 10, 11 only ring on all incoming CO/PBX calls
5-03	Ringing Assignment -Night	Port 10, 11 only ring on all incoming CO/PBX calls
5-04	Non/Toll/Outgoing Restriction	No Restriction on any CO/PBX line or telephone
6-A	Speed Dialing Clear (System)	
6-B	Speed Dialing Clear (Telephone)	
6-C	ROM Version Confirmation	

## SECTION 340 SYSTEM PROGRAMMING DATA SHEETS

### MEMORY BLOCK 1 - 01

### HOOK FLASH TIME SELECTION

MEMORY BLOCK BEING PROGRAMMED	MEMORY BLOCK THAT MUST BE PROGRAMMED	MEMORY BLOCK THAT MAY HAVE TO BE PROGRAMMED
<b>1 - 01</b>		

OPERATION ← AND → DISPLAY

2. Depress LK1.



3. Dial 0, then 1, to specify function № 01.



4. Input data (0-3) with dial pad. Example: to set 0.4 seconds as data for CO/PBX line, input 0 (see Notes 1 & 2)



5. Depress MIC key (see Note 3)

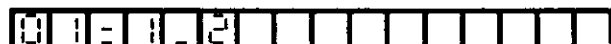


6. Depress SPKR key to go back on line.



#### NOTES:

1. Dial \* (←), # (→) to move the setting position then input data or function No.



Function No.      Data position NOT USED  
Data position for CO/PBX Line

2. Data Table      Default value\*

CO/PBX Line	
Code	Feature
0	0.4 sec.
* 1	0.6 sec.
2	1.0 sec.
3	1.5 sec.

3. Depressing the MIC key enters the data and causes the display to increment to the next function number.

### GENERAL INFORMATION - HOOK FLASH TIME SELECTION

This memory block area is used to enter the instantaneous break time of the hook flash signal to be sent to a CO/PBX line when the RECALL key on a Key Telephone is depressed. The Hook flash signal momentarily breaks the DC loop of a CO/PBX line.

## MEMORY BLOCK 1 - 02 HOLD RECALL TIME SELECTION

MEMORY BLOCK BEING PROGRAMMED	MEMORY BLOCK THAT MUST BE PROGRAMMED	MEMORY BLOCK THAT MAY HAVE TO BE PROGRAMMED
<b>1 - 02</b>		

OPERATION ← AND → DISPLAY

2. Depress LK1.



3. Dial 0, then 2, to specify function № 02.



4. Input data (0-3) with dial pad. Example: Input 2 to select 4 minutes (See Notes 1 & 2).



5. Depress MIC key (see Note 3)



6. Depress SPKR key to go back on line.



**NOTES:**

1. Dial \* (←), # (→) to move the setting position then input data or function No.



Function No.      Data setting position

3. Depressing the MIC key enters the data and causes the display to increment to the next function number.

2. Data Table      Default value\*

Code	Feature
0	1 min.
* 1	2 min.
2	4 min.
3	No limit

### GENERAL INFORMATION - HOLD RECALL TIME SELECTION

This memory block area is used to enter the time for the Hold Recall to start (both visual and audible). If No limit is selected, there will not be any Hold Recall. This timer is used for both Exclusive and Nonexclusive Hold.

## MEMORY BLOCK 1 - 03 PAGING TIME OUT SELECTION

MEMORY BLOCK BEING PROGRAMMED	MEMORY BLOCK THAT MUST BE PROGRAMMED	MEMORY BLOCK THAT MAY HAVE TO BE PROGRAMMED
1 - 03	4-01	1-25

OPERATION ← AND → DISPLAY

2. Depress LK1.



3. Dial 0, then 3, to specify function № 03.



4. Input data (0-2) with dial pad. Example: Input 1 to select 120 seconds (See Notes 1 and 2).



5. Depress MIC key (see Note 3)



6. Depress SPKR key to go back on line.



**NOTES:**

1. Dial \* (←), # (→) to move the setting position then input data or function No.



Function No.      Data setting position

3. Depressing the MIC key enters the data and causes the display to increment to the next function number.

2. Data Table      Default value\*

Code	Feature
* 0	90 sec.
1	120 sec.
2	No limit

### GENERAL INFORMATION - PAGING TIME OUT SELECTION

This memory block area is used to enter the duration of internal zone paging and external speaker paging.

## MEMORY BLOCK 1 - 05 PAUSE TIME AND INTERDIGIT TIME SELECTION

MEMORY BLOCK BEING PROGRAMMED	MEMORY BLOCK THAT MUST BE PROGRAMMED	MEMORY BLOCK THAT MAY HAVE TO BE PROGRAMMED
<b>1 - 05</b>		1-27,1-28
		3-09

**OPERATION** ← AND → **DISPLAY**

2. Depress LK1.



3. Dial 0, then 5, to specify function № 05.



4. Input data (0-1) with dial pad. Example: Input 0 to select 1 second as a pause time (See Notes 1 & 2), input interdigit time data (See Note 2).



5. Depress MIC key (see Note 3)

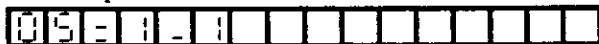


6. Depress SPKR key to go back on line.



**NOTES:**

1. Dial \* (←), # (→) to move the setting position then input data or function No.



Function No.      Data position for interdigit time  
 Data position for pause time

2. Data Table      Default value\*

Pause time		Interdigit time	
Code	Feature	Code	Feature
0	1.0 sec.	0	700 msec. @10pps 550 msec. @20pps
* 1	3.5 sec.	* 1	800 msec.

3. Depressing the MIC key enters the data and causes the display to increment to the next function number.

### GENERAL INFORMATION - PAUSE TIME AND INTERDIGIT TIME SELECTION

Pause Time refers to the time in which no dial signals will be sent to the CO/PBX line. This is the amount of time that the system will wait after a PBX access code or a pause has been entered into a System or Station Speed Dial buffer. Interdigit time is the amount of time that the system will wait between sending digits to the CO/PBX line. The interdigit time selection pertains only to Dial Pulse lines.



## MEMORY BLOCK 1 - 07 DOOR PHONE DISPLAY TIME SELECTION

MEMORY BLOCK BEING PROGRAMMED	MEMORY BLOCK THAT MUST BE PROGRAMMED	MEMORY BLOCK THAT MAY HAVE TO BE PROGRAMMED
1 - 07	1-31, 4-06	1-42

**OPERATION** ← AND → **DISPLAY**

2. Depress LK1.



3. Dial 0, then 7, to specify function № 07.



4. Input data (0-3) with dial pad. Example: Input 1 to select 30 seconds (See Notes 1 and 2)



5. Depress MIC key (see Note 3)



6. Depress SPKR key to go back on line.



**NOTES:**

1. Dial \* (←),# (→) to move the setting position then input data or function No.



Function No.      Data setting position

3. Depressing the MIC key enters the data and causes the display to increment to the next function number.

2. Data Table      Default value\*

Code	Feature
* 0	10 sec.
1	30 sec.
2	60 sec.
3	90 sec.

### GENERAL INFORMATION - DOOR PHONE DISPLAY TIME SELECTION

This memory block area is used to enter the time during which DOOR PHONE 1 or DOOR PHONE 2 is displayed on an ETZ-16D-1 Key Telephone that is assigned to ring upon access by a Door Phone. This same parameter is used for the warning tone given to a station user when off-hook, when a Door Phone is activated, and for the time interval for which a station can answer an incoming call from a Door Phone (if the Door Phone is programmed for automatic call answer).

## MEMORY BLOCK 1 - 08 RING TRANSFER RECALL TIME SELECTION

MEMORY BLOCK BEING PROGRAMMED	MEMORY BLOCK THAT MUST BE PROGRAMMED	MEMORY BLOCK THAT MAY HAVE TO BE PROGRAMMED
<b>1 - 08</b>		1-18

OPERATION ← AND → DISPLAY

2. Depress LK1.



3. Dial 0, then 8, to specify function № 08.



4. Input data (0-3) with dial pad. Example: Input 2 to select 2 minutes (See Notes 1 and 2).



5. Depress MIC key (see Note 3)

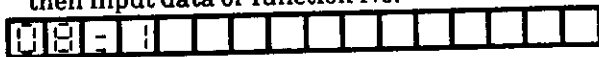


6. Depress SPKR key to go back on line.



**NOTES:**

1. Dial \* (←),# (→) to move the setting position then input data or function No.



Function No.      Data setting position

3. Depressing the MIC key enters the data and causes the display to increment to the next function number.

2. Data Table      Default value\*

Code	Feature
0	30 sec.
* 1	1 min.
2	2 min.
3	4 min.

### GENERAL INFORMATION - RING TRANSFER RECALL TIME SELECTION

This memory block area is used to enter the time for the Recall to occur at the Key Telephone that ring transferred a call, if the transferred call was not answered within the preprogrammed time interval.

## MEMORY BLOCK 1 - 09 AUTOMATIC CALLBACK TIME SELECTION

MEMORY BLOCK BEING PROGRAMMED	MEMORY BLOCK THAT MUST BE PROGRAMMED	MEMORY BLOCK THAT MAY HAVE TO BE PROGRAMMED
1 - 09		

OPERATION ← AND → DISPLAY

2. Depress LK1.



3. Dial 0, then 9, to specify function No 09.



4. Input data (0-3) with dial pad. Example: Input 1 to select 60 minutes (See Notes 1 and 2)



5. Depress MIC key (see Note 3)



6. Depress SPKR key to go back on line.



### NOTES:

1. Dial \* (←), # (→) to move the setting position then input data or function No.



Function No.      Data setting position

3. Depressing the MIC key enters the data and causes the display to increment to the next function number.

2. Data Table      Default value\*

Code	Feature
0	30 min.
1	60 min.
2	90 min.
*3	No Limit

4. The audible signal that is received by the sending station, when the called station returns to an idle condition, is fixed at 30 seconds.

### GENERAL INFORMATION - AUTOMATIC CALLBACK TIME SELECTION

This memory block area is used to enter the time from when a Callback is set till its release.

## MEMORY BLOCK 1 - 10 AUTOMATIC REDIAL TIME SELECTION

MEMORY BLOCK BEING PROGRAMMED	MEMORY BLOCK THAT MUST BE PROGRAMMED	MEMORY BLOCK THAT MAY HAVE TO BE PROGRAMMED
<b>1 - 10</b>		

OPERATION ← AND → DISPLAY

2. Depress LK1.



3. Dial 1, then 0, to specify function № 10.



4. Input data (0-3) with dial pad. Example: Input 1 to select 60 seconds Callback time, 90 second waiting time, repeat 5 times (See Notes 1 & 2).



5. Depress MIC key (see Note 3)



6. Depress SPKR key to go back on line.



**NOTES:**

1. Dial \* (←), # (→) to move the setting position then input data or function No.



3. Depressing the MIC key enters the data and causes the display to increment to the next function number.

2. Data Table Default value\*

Code	Feature		
	Callback time	Waiting time	Repeat
* 0	60 sec.	120 sec.	5
1	60 sec.	90 sec.	5
2	40 sec.	60 sec.	5
3	30 sec.	30 sec.	5

Callback Time = How long the call will be monitored by the system before it releases the CO/PBX call.

Waiting Time = Is the time between redial attempts.

### GENERAL INFORMATION - AUTOMATIC REDIAL TIME SELECTION

This memory block area is used to enter the monitoring time and waiting time in between each dialing attempt.

## MEMORY BLOCK 1 - 12 ELAPSED CALL & SMDR START TIMER SELECTION

MEMORY BLOCK BEING PROGRAMMED	MEMORY BLOCK THAT MUST BE PROGRAMMED	MEMORY BLOCK THAT MAY HAVE TO BE PROGRAMMED
1 - 12		3-09

OPERATION ← AND → DISPLAY

2. Depress LK1.

1-1-2

3. Dial 1, then 2, to specify function № 12.

12-0

4. Input data (0-2) with dial pad. Example: Input 1 to select 20 seconds (See Notes 1 & 2).

12-1

5. Depress MIC key (see Note 3)

12-1

6. Depress SPKR key to go back on line.

2-12 11-599



### NOTES:

1. Dial \* (←), # (→) to move the setting position then input data or function No.

12-0

└──┘
└──┘  
 Function No.      Data setting position

3. Depressing the MIC key enters the data and causes the display to increment to the next function number.

2. Data Table      Default value\*

Code	Feature
* 0	10 sec.
1	20 sec.
2	30 sec.

### GENERAL INFORMATION - ELAPSED CALL & SMDR START TIMER SELECTION

This memory block area is used to enter the time in which the Elapsed call timer will start when originating a CO call. This same parameter is used as the SMDR start time. This is the amount of time that must elapse after the last dialed digit in order to present an SMDR call record.

## MEMORY BLOCK 1 - 13 INTERCOM CALL SIGNAL TONE / VOICE SELECTION

MEMORY BLOCK BEING PROGRAMMED	MEMORY BLOCK THAT MUST BE PROGRAMMED	MEMORY BLOCK THAT MAY HAVE TO BE PROGRAMMED
<b>1 - 13</b>		

OPERATION ← AND → DISPLAY

2. Depress LK1.



3. Dial 1, then 3, to specify function № 13.



4. Input data (0-1) with dial pad. Example: Input 0 to select signal tone (See Notes 1 and 2)



5. Depress MIC key (see Note 3)



6. Depress SPKR key to go back on line.



**NOTES:**

1. Dial \* (←), # (→) to move the setting position then input data or function No.



3. Depressing the MIC key enters the data and causes the display to increment to the next function number.

2. Data Table Default value\*

Code	Feature
0	Tone
* 1	Voice

**GENERAL INFORMATION - INTERCOM CALL SIGNAL TONE/VOICE SELECTION**

This memory block area is used to specify the type of signal to be received on internal calls (Tone or Voice first). The originating user can toggle between Voice and Tone, by simple button depressions.

## MEMORY BLOCK 1 - 14 STATION BGM CONNECTION (ALLOW/DENY)

MEMORY BLOCK BEING PROGRAMMED	MEMORY BLOCK THAT MUST BE PROGRAMMED	MEMORY BLOCK THAT MAY HAVE TO BE PROGRAMMED
1 - 14		

OPERATION ← AND → DISPLAY

2. Depress LK1.

01-1-2

3. Dial 1, then 4, to specify function № 14.

14-0

4. Input data (0-1) with dial pad. Example: Input 1 to select Allow (See Notes 1 & 2).

14-1

5. Depress MIC key (see Note 3)

15-0

6. Depress SPKR key to go back on line.

2-12 11-99A



### NOTES:

1. Dial \* (←),# (→) to move the setting position then input data or function No.

14-0

└─┬─┘
└─┬─┘  
 Function No.      Data setting position

3. Depressing the MIC key enters the data and causes the display to increment to the next function number.

2. Data Table      Default value\*

Code	Feature
* 0	Deny
1	Allow

4. This feature, when enabled, requires a dedicated intercom path. This will leave the system with 4 remaining intercom paths for internal calls.

### GENERAL INFORMATION - STATION BGM CONNECTION (ALLOW/DENY)

This memory block area is used to specify if Background Music will be supplied to a Key Telephone speaker when the proper feature access code is dialed and a locally provided music source is connected.

## MEMORY BLOCK 1 - 15 CANCELLATION OF SYSTEM SPEED DIAL TOLL OVERRIDE

MEMORY BLOCK BEING PROGRAMMED	MEMORY BLOCK THAT MUST BE PROGRAMMED	MEMORY BLOCK THAT MAY HAVE TO BE PROGRAMMED
<b>1 - 15</b>	5-01	
	5-04	

OPERATION ← AND → DISPLAY

2. Depress LK1.



3. Dial 1, then 5, to specify function № 15.



4. Input data (0-1) with dial pad. Example: Input 1 to select Cancel (See Notes 1 & 2)



5. Depress MIC key (see Note 3)

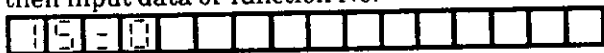


6. Depress SPKR key to go back on line.



**NOTES:**

1. Dial \* (←), # (→) to move the setting position then input data or function No.



3. Depressing the MIC key enters the data and causes the display to increment to the next function number.

2. Data Table Default value\*

Code	Feature
* 0	Not canceled
1	Cancel

**GENERAL INFORMATION - CANCELLATION OF SYSTEM SPEED DIAL TOLL  
 OVERRIDE**

This memory block area is used to allow System Speed Dial buffers 20 through 39 to bypass Toll Restriction parameters. The remaining buffers (40-99) will not allow a restricted station to make long distance calls.



## MEMORY BLOCK 1 - 16 SYSTEM SPEED DIALING CONFIRMATION TELEPHONE

MEMORY BLOCK BEING PROGRAMMED	MEMORY BLOCK THAT MUST BE PROGRAMMED	MEMORY BLOCK THAT MAY HAVE TO BE PROGRAMMED
1 - 16		

OPERATION ← AND → DISPLAY

2. Depress LK1.



3. Dial 1, then 6, to specify function № 16.



4. Input data (0-1) with dial pad. Example: Input 1 to select All telephones (See Notes 1 & 2).



5. Depress MIC key (see Note 3).



6. Depress SPKR key to go back on line.



**NOTES:**

1. Dial \* (←), # (→) to move the setting position then input data or function No.



Function No.      Data setting position

3. Depressing the MIC key enters the data and causes the display to increment to the next function number.

2. Data Table      Default value\*

Code	Feature
* 0	Ports 10 and 11 only
1	All telephones

### GENERAL INFORMATION - SYSTEM SPEED DIALING CONFIRMATION TELEPHONE

This memory block area is used to specify whether the Attendant positions or all stations can examine system speed dial buffer contents as well as the parameter that determines whether telephone numbers are displayed or not, when initiating System Speed Dialing by stations other than Attendants.

## MEMORY BLOCK 1 - 17 DSS/BLF CONSOLE ASSIGNMENT

MEMORY BLOCK BEING PROGRAMMED	MEMORY BLOCK THAT MUST BE PROGRAMMED	MEMORY BLOCK THAT MAY HAVE TO BE PROGRAMMED
<b>1 - 17</b>		<b>4-01</b>

**OPERATION** ← AND → **DISPLAY**

2. Depress LK1.



3. Dial 1, then 7, to specify function No 17.



4. Input data with dial pad. Example: When DSS1 is assigned to port No. 12 its Attendant is port No. 10.  
Repeat steps to set DSS 2.



5. Depress MIC key (see Note 3)

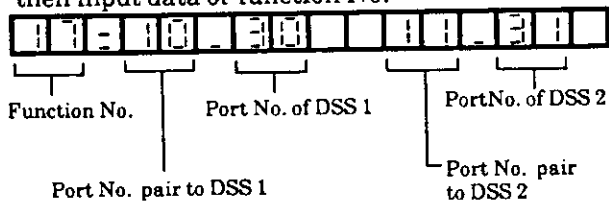


6. Depress SPKR key to go back on line.



**NOTES:**

1. Dial \* (←), # (→) to move the setting position then input data or function No.



If neither DSS 1 or DSS 2 are installed, the areas showing their port numbers will be blank.

2. Data and keys used to input data

Key	Feature
Dial key	Port pair to DSS : (Port 10-33) No. of DSS :(Port 12-33)
HOLD	Clear 1 data (2 digits)

Default value: Ports No. 10 and 11 are Attendants to DSS1 and 2, respectively. DSS numbers are the port numbers provided at first power on.

3. Depressing the MIC key enters the data and causes the display to increment to the next function number.

4. A DSS/BLF cannot share the same port as the Tandem Conference feature.

### GENERAL INFORMATION - DSS/BLF CONSOLE ASSIGNMENT

This memory block area is used to specify ports to which DSS/BLF Consoles are connected. Up to two DSS/BLF Consoles can be connected per system.

## MEMORY BLOCK 1 - 18 RINGING TONE TRANSFER

MEMORY BLOCK BEING PROGRAMMED	MEMORY BLOCK THAT MUST BE PROGRAMMED	MEMORY BLOCK THAT MAY HAVE TO BE PROGRAMMED
<b>1 - 18</b>	5-02	1-08
	5-03	

OPERATION ← AND → DISPLAY

2. Depress LK1.



3. Dial 1, then 8, to specify function № 18.



4. Input data (0-1) with dial pad. Example: Input 0 to select Deny (See Notes 1 & 2).



5. Depress MIC key (see Note 3)

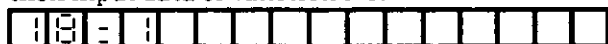


6. Depress SPKR key to go back on line.



### NOTES:

1. Dial \* (←), # (→) to move the setting position then input data or function No.



Function No.      Data setting position

3. Depressing the MIC key enters the data and causes the display to increment to the next function number.

2. Data Table      Default value\*

Code	Feature
0	Deny
* 1	Allow

## GENERAL INFORMATION - RINGING TONE TRANSFER

This memory block area is used to allow or deny Ringing Tone Transfer from all Key Telephones.

## MEMORY BLOCK 1 - 19 TIME DISPLAY SWITCHING (12 h/24 h)

MEMORY BLOCK BEING PROGRAMMED	MEMORY BLOCK THAT MUST BE PROGRAMMED	MEMORY BLOCK THAT MAY HAVE TO BE PROGRAMMED
<b>1 - 19</b>		

OPERATION ← AND → DISPLAY

2. Depress LK1.



3. Dial 1, then 9, to specify function No 19.



4. Input data (0-1) with dial pad. Example: Input 1 to select 24 hour system (See Notes 1 & 2).



5. Depress MIC key (see Note 3)



6. Depress SPKR key to go back on line.



**NOTES:**

1. Dial \* (←), # (→) to move the setting position then input data or function No.



3. Depressing the MIC key enters the data and causes the display to increment to the next function number.

2. Data Table Default value\*

Code	Feature
* 0	12 hour system
1	24 hour system

### GENERAL INFORMATION - TIME DISPLAY SWITCHING (12h/24h)

This memory block area is used to select either a 12-hour clock or a 24-hour clock for the time displayed on the Key Telephones (ETZ-16D-1). 12 hour clock: 12:00 A.M. to 11:59 P.M.  
 24 hour clock: 0:00 to 23:59

## MEMORY BLOCK 1 - 20 OFF HOOK RINGING TONE

MEMORY BLOCK BEING PROGRAMMED	MEMORY BLOCK THAT MUST BE PROGRAMMED	MEMORY BLOCK THAT MAY HAVE TO BE PROGRAMMED
<b>1 - 20</b>		4-02,
		5-01, 5-02,
		5-03

OPERATION ← AND → DISPLAY

2. Depress LK1.



3. Dial 2, then 0, to specify function No 20.



4. Input data (0-1) with dial pad. Example: Input 0 to select Deny (See Notes 1 & 2).



5. Depress MIC key (see Note 3).



6. Depress SPKR key to go back on line.



### NOTES:

1. Dial \* (←), # (→) to move the setting position then input data or function No.



Function No.      Data setting position

3. Depressing the MIC key enters the data and causes the display to increment to the next function number.

2. Data Table      Default value\*

Code	Feature
0	Deny
* 1	Allow

4. This parameter must be allowed for off-hook ring to function.

### GENERAL INFORMATION - OFF HOOK RINGING TONE

This memory block area is used to specify whether or not to provide an off-hook audible ring tone to a ring assigned Key Telephone when it is off-hook using its handset.

## MEMORY BLOCK 1 - 21 DTMF DIGIT DURATION SELECTION

MEMORY BLOCK BEING PROGRAMMED	MEMORY BLOCK THAT MUST BE PROGRAMMED	MEMORY BLOCK THAT MAY HAVE TO BE PROGRAMMED
<b>1 - 21</b>		<b>3-09</b>

**OPERATION** ← AND → **DISPLAY**

2. Depress LK1.



3. Dial 2, then 1, to specify function № 21.



4. Input data (0-1) with dial pad. Example: Input 1 to select 300 msec. (See Notes 1 & 2)



5. Depress MIC key (see Note 3)



6. Depress SPKR key to go back on line.



### NOTES:

1. Dial \* (←), # (→) to move the setting position then input data or function No.



3. Depressing the MIC key enters the data and causes the display to increment to the next function number.

2. Data Table Default value\*

Code	Digit Duration
* 0	100 msec.
1	300 msec.

### GENERAL INFORMATION - DTMF DIGIT DURATION SELECTION

This memory block area is used to set the DTMF Digit Duration for each digit dialed on an outside line.

## MEMORY BLOCK 1 - 23 HANDSET RECEIVING VOLUME

MEMORY BLOCK BEING PROGRAMMED	MEMORY BLOCK THAT MUST BE PROGRAMMED	MEMORY BLOCK THAT MAY HAVE TO BE PROGRAMMED
<b>1 - 23</b>		

OPERATION ← AND → DISPLAY

2. Depress LK1.



3. Dial 2, then 3, to specify function № 23.



4. Input data (0-1) with dial pad. Example: Input 1 to select Up (See Notes 1 & 2)



5. Depress MIC key (see Note 3)

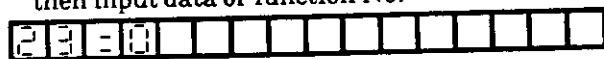


6. Depress SPKR key to go back on line.



### NOTES:

1. Dial \* (←), # (→) to move the setting position then input data or function No.



Function No.      Data setting position

3. Depressing the MIC key enters the data and causes the display to increment to the next function number.

2. Data Table      Default value\*

Code	Feature
* 0	Down
1	Up

Down: The volume increase is reset when you hang up.

Up: The volume increase is not reset when you hang up.






### GENERAL INFORMATION - HANDSET RECEIVING VOLUME

This memory block area is used to specify, when a Key Telephone raises its receiving volume during a call, either *return to normal volume* or *stay at the raised volume* after the call is terminated and the handset is returned to the handset cradle.

## MEMORY BLOCK 1 - 24 PRIVACY OVERRIDE TONE ON CO/PBX LINE (ALLOW/DENY)

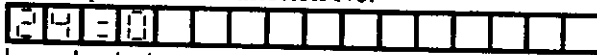
MEMORY BLOCK BEING PROGRAMMED	MEMORY BLOCK THAT MUST BE PROGRAMMED	MEMORY BLOCK THAT MAY HAVE TO BE PROGRAMMED
1 - 24	1-29	

OPERATION ← AND → DISPLAY

2. Depress LK1. 
3. Dial 2, then 4, to specify function № 24. 
4. Input data with dial pad. Example: Input 1 to select Allow (See Notes 1 & 2). 
5. Depress MIC key (see Note 3). 
6. Depress SPKR key to go back on line. 

**NOTES:**

1. Dial \* (←), # (→) to move the setting position then input data or function No. 3. Depressing the MIC key enters the data and causes the display to increment to the next function number.



2. Data Table Default value\*

Code	Feature
* 0	Deny
1	Allow

### GENERAL INFORMATION - PRIVACY OVERRIDE TONE ON CO/PBX LINE (ALLOW/DENY)

This memory block area is used to specify whether or not to send an Override Tone to both the overridden and overriding Key Telephone when the conversation is interrupted.



## MEMORY BLOCK 1 - 25 EXTERNAL SPEAKER (CONNECTED / NOT CONNECTED)

MEMORY BLOCK BEING PROGRAMMED	MEMORY BLOCK THAT MUST BE PROGRAMMED	MEMORY BLOCK THAT MAY HAVE TO BE PROGRAMMED
<b>1 - 25</b>		<b>1-03</b>

**OPERATION ← AND → DISPLAY**

2. Depress LK1.



3. Dial 2, then 5, to specify function № 25.



4. Input data (0-1) with dial pad. Example: When speaker 2 is not connected.



① Move setting position (See Note 1).

② Input 0 (See Note 2).



Similarly, operate as above to input setting of speaker 1

5. Depress MIC key (see Note 3)



6. Depress SPKR key to go back on line.



**NOTES:**

1. Dial \* (←),# (→) to move the setting position then input data or function No.



Function No. [bracket]      [bracket] Data position for speaker 2  
[bracket] Data position for speaker 1

3. Depressing the MIC key enters the data and causes the display to increment to the next function number.

2. Data Table      Default value\*

Code	Feature
0	Not connected
* 1	Connected

### GENERAL INFORMATION - EXTERNAL SPEAKER (CONNECTED / NOT CONNECTED)

This memory block area is used to specify whether external speakers are connected or not.

## MEMORY BLOCK 1 - 26 LINE SELECTION CODES

MEMORY BLOCK BEING PROGRAMMED	MEMORY BLOCK THAT MUST BE PROGRAMMED	MEMORY BLOCK THAT MAY HAVE TO BE PROGRAMMED
1 - 26	3-09	4-02
		4-04

OPERATION ← AND → DISPLAY

2. Depress LK1.



3. Dial 2, then 6, to specify function № 26.



4. Input data (0-3) with dial pad. Example: When code 80 is specified to seize PBX line.



① Move setting position (See Note 1).



② Input 1 (See Note 2).

Similarly, operate as above to specify codes 9 and 88 for line seizure.

5. Depress MIC key (see Note 3).

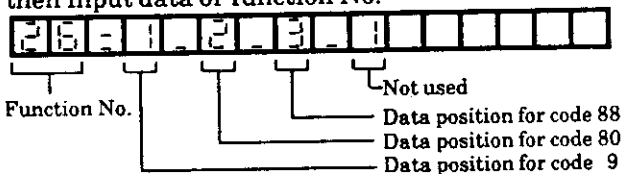


6. Depress SPKR key to go back on line.



**NOTES:**

1. Dial \* (←), # (→) to move the setting position then input data or function No.



3. Depressing the MIC key enters the data and causes the display to increment to the next function number.

2. Data Table

Code	Feature
0	NONE
1	CO line
2	PBX line
3	—

Default value  
 Code 9: CO line  
 Code 80: PBX line  
 Code 88: —

### GENERAL INFORMATION - LINE SELECTION CODES

This memory block area is used to specify what type of lines are associated with the fixed trunk access codes.

## MEMORY BLOCK 1 - 27 PBX ACCESS CODE ASSIGNMENT-I

MEMORY BLOCK BEING PROGRAMMED	MEMORY BLOCK THAT MUST BE PROGRAMMED	MEMORY BLOCK THAT MAY HAVE TO BE PROGRAMMED
1 - 27	3-09	1-05

OPERATION ← AND → DISPLAY

2. Depress LK1. | 1 | 2 | 3 | 4 | 5 | 6 | 7 | 8 | 9 | 0 | - | \* |
3. Dial 2, then 7, to specify function № 27. | 2 | 7 | 8 | - | 0 | 1 | 2 | 3 | 4 | 5 | 6 | 7 | 8 | 9 |
4. Input data (0-9) with dial pad. Example: Input 8-22- (See Notes 1 & 2). | 2 | 7 | 8 | - | 2 | 2 | - | 0 | 1 | 2 | 3 | 4 | 5 | 6 | 7 | 8 | 9 |
5. Depress MIC key (see Note 3). | 2 | 7 | 8 | - | 8 | 2 | 2 | - | 0 | 1 | 2 | 3 | 4 | 5 | 6 | 7 | 8 | 9 |
6. Depress SPKR key to go back on line. | 0 | 1 | 2 | - | 1 | 2 | 3 | 4 | 5 | 6 | 7 | 8 | 9 |

**NOTES:**

1. Dial \* (←), # (→) to move the setting position then input data or function No.



Function No.                      Data setting position (Max. 6 digits)

Consecutive pauses cannot be entered, i.e. 8- -. A pause cannot be entered as the first digit, i.e. - 8.

2. Data and keys used to input data

Key	Feature
Dial key	Data
LNR/SPD	Pause
HOLD	All clear

Default value: 8-

Numerals (maximum of 3) and pauses (maximum of 3) up to 6 digits at the maximum can be input as the outgoing code.

3. Depressing the MIC key enters the data and causes the display to increment to the next function number.

### GENERAL INFORMATION - PBX ACCESS CODE ASSIGNMENT-I

This memory block area is used to allow a station user to dial access to a PBX line without the Toll Restriction inspection occurring.

## MEMORY BLOCK 1 - 28 PBX ACCESS CODE ASSIGNMENT-II

MEMORY BLOCK BEING PROGRAMMED	MEMORY BLOCK THAT MUST BE PROGRAMMED	MEMORY BLOCK THAT MAY HAVE TO BE PROGRAMMED
1 - 28	3-09	1-05

OPERATION ← AND → DISPLAY

2. Depress LK1.



3. Dial 2, then 8, to specify function № 28.



4. Input data with dial pad. Example: Input 8-22- (See Notes 1 & 2).



5. Depress MIC key (see Note 3).



6. Depress SPKR key to go back on line.



**NOTES:**

1. Dial \* (←), # (→) to move the setting position then input data or function No.

Consecutive pauses cannot be entered, i.e. 9 - -. A pause cannot be entered as the first digit, i.e. - 9.



Function No.                      Data setting position (Max. 6 digits)

2. Data and keys used to input data

Key	Feature
Dial key	Data
LNR/SPD	Pause
HOLD	All clear

Default value: 9-

3. Depressing the MIC key enters the data and causes the display to increment to the next function number.

Numerals (maximum of 3) and pauses (maximum of 3) up to 6 digits at the maximum can be input as the outgoing code.

### GENERAL INFORMATION - PBX ACCESS CODE ASSIGNMENT-II

This memory block area is used to allow a station user to dial access to a PBX line without the Toll Restriction inspection occurring.

## MEMORY BLOCK 1 - 29 PRIVACY OVERRIDE ASSIGNMENT

MEMORY BLOCK BEING PROGRAMMED	MEMORY BLOCK THAT MUST BE PROGRAMMED	MEMORY BLOCK THAT MAY HAVE TO BE PROGRAMMED
<b>1 - 29</b>		<b>1-24</b>

OPERATION ← AND → DISPLAY

2. Depress LK1.

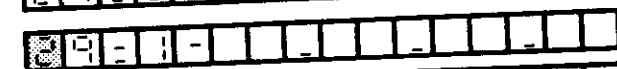
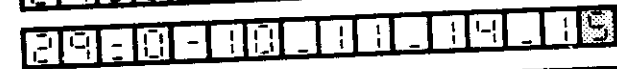
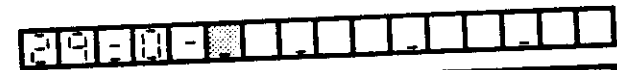


3. Dial 2, then 9, to specify function № 29.



4. Input data with dial pad. Example: When port Nos. 10, 11, 14, 15, 18, 19 and 20 are input.

- ① Move setting position (See Note 1).
- ② Input data (10, 11, 14, 15). (See Note 2).
- ③ Depress MIC key (See Note 3).
- ④ Repeat steps ① and ② to input data (18, 19, 20) in page 1.



5. Depress MIC key (see Note 3).

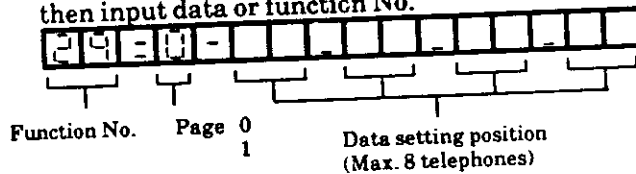


6. Depress SPKR key to go back on line.



**NOTES:**

1. Dial \* (←), # (→) to move the setting position then input data or function No.



3. Depressing the MIC key while setting page 0 enters the data and causes the display to increment to the next page number.

2. Data and keys used to input data

Key	Feature
Dial key	Port Nos. 10-33
HOLD	Clear 1 data (2 digits)

Default value: NONE

4. Depressing the MIC key while setting page 1 enters the data and causes the display to increment to the next function.

### GENERAL INFORMATION - PRIVACY OVERRIDE ASSIGNMENT

This memory block area is used to specify which Key Telephones (maximum of eight per system) can Override calls of other stations on CO/PBX lines.

## MEMORY BLOCK 1 - 30 PRIVATE LINE ASSIGNMENT

MEMORY BLOCK BEING PROGRAMMED	MEMORY BLOCK THAT MUST BE PROGRAMMED	MEMORY BLOCK THAT MAY HAVE TO BE PROGRAMMED
<b>1 - 30</b>		

OPERATION ← AND → DISPLAY

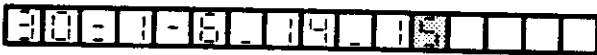
2. Depress LK1.



3. Dial 3, then 0, to specify function № 30.



4. Input data with dial pad. Example: When port No. 12, 13 are assigned to CO 5, and port No. 14, 15 to CO 6.



- ① Move setting position (See Note 1).
- ② Input data (5 : 12, 13). (See Note 2).
- ③ Depress MIC key (See Note 3).
- ④ Repeat steps ① and ② to input data in page 1.

5. Depress MIC key (see Note 3).



6. Depress SPKR key to go back on line.



**NOTES:**

1. Dial \* (←), # (→) to move the setting position then input data or function No.



Function No. | Page 0 | CO/PBX line No. | Port No. | Port No.

3. Depressing the MIC key enters the data for page 0 and causes the display to increment to page 1.

4. Depressing the MIC key while setting page 1 causes the display to increment to the next function.

2. Data and keys used to input

Key	Feature
Dial key	CO line No. (1-8)
	Port No. (10-33)
HOLD	Clear 1 data (1 or 2 digits)

Default value: No Station Assigned

### GENERAL INFORMATION - PRIVATE LINE ASSIGNMENT

This memory block area is used to assign a CO/PBX line to two Key Telephones in the system for private use. Up to two groups, each consisting of one CO/PBX line assigned to two Key Telephones, can be entered.

## MEMORY BLOCK 1 - 31 DOOR PHONE ASSIGNMENT (INSTALLED/NOT INSTALLED)

MEMORY BLOCK BEING PROGRAMMED	MEMORY BLOCK THAT MUST BE PROGRAMMED	MEMORY BLOCK THAT MAY HAVE TO BE PROGRAMMED
<b>1 - 31</b>		1-07
		1-42
		4-06

OPERATION ← AND → DISPLAY

2. Depress LK1.



3. Dial 3, then 1, to specify function № 31.



4. Input data with dial pad. Example: When Door Phone 2 is not installed.  
 ⓐ Move setting position (see Note 1).  
 ⓑ Input 0 (see Note 2).



5. Depress MIC key (see Note 3).

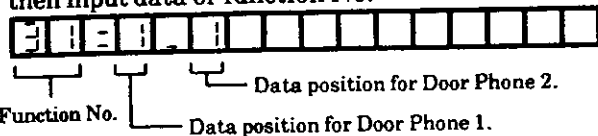


6. Depress SPKR key to go back on line.



**NOTES:**

1. Dial \* (←), # (→) to move the setting position then input data or function No.



3. Depressing the MIC key enters the data and causes the display to increment to the next function number.

2. Data Table      Default value\*

Code	Feature
0	Not installed
* 1	Installed

### GENERAL INFORMATION - DOOR PHONE ASSIGNMENT (INSTALLED/NOT INSTALLED)

This memory block area is used to specify whether or not Door Phones are installed.

## MEMORY BLOCK 1 - 32 DOOR LOCK RELEASE (ALLOW/DENY)

MEMORY BLOCK BEING PROGRAMMED	MEMORY BLOCK THAT MUST BE PROGRAMMED	MEMORY BLOCK THAT MAY HAVE TO BE PROGRAMMED
1 - 32	1-31	

**OPERATION** ← **AND** → **DISPLAY**

2. Depress LK1.



3. Dial 3, then 2, to specify function № 32.



4. Input data (0 or 1) with dial pad. Example: When Door Lock 2 is not needed.



- ⊙ Move setting position (see Note 1).
- ⊙ Input 0 (see Note 2).

5. Depress MIC key (see Note 3).



6. Depress SPKR key to go back on line.



**NOTES:**

1. Dial \* (←), # (→) to move the setting position then input data or function No.



Function No.      Data setting position for Door Lock 2.  
 Data setting position for Door Lock 1.

3. Depressing the MIC key enters the data and causes the display to increment to the next function number.

2. Data Table      Default value\*

Code	Feature
0	Deny
* 1	Allow

### GENERAL INFORMATION - DOOR LOCK RELEASE (ALLOW/DENY)

This memory block area is used to specify whether or not to allow control of the external relay circuit on the Door Phone KTU (DPH-Z).



## MEMORY BLOCK 1 - 34 SMDR PRINT FORMAT

MEMORY BLOCK BEING PROGRAMMED	MEMORY BLOCK THAT MUST BE PROGRAMMED	MEMORY BLOCK THAT MAY HAVE TO BE PROGRAMMED
<b>1 - 34</b>		

OPERATION ← AND → DISPLAY

2. Depress LK1.



3. Dial 3, then 4, to specify function № 34.



4. Input data (0 or 1) with dial pad. Example: Input 1 to select *Mask last 4 digits* (See Notes 1 & 2)



5. Depress MIC key (see Note 3).



6. Depress SPKR key to go back on line.



### NOTES:

1. Dial \* (←), # (→) to move the setting position then input data or function No.



Function No.      Data setting position

3. Depressing the MIC key enters the data and causes the display to increment to the next function number.

2. Data Table      Default value\*

Code	Feature
* 0	All
1	Mask last 4 digits

Example: When Data 1 is set: 516 753 ----








### GENERAL INFORMATION - SMDR PRINT FORMAT

This memory block area is used to specify whether or not to print out all the digits or all the digits except the last four, of the called telephone number.

## MEMORY BLOCK 1 - 36 INTERCOM MASTER NUMBER

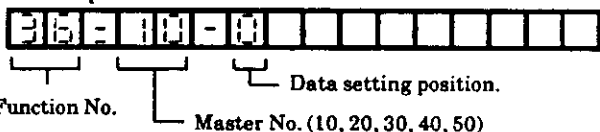
MEMORY BLOCK BEING PROGRAMMED	MEMORY BLOCK THAT MUST BE PROGRAMMED	MEMORY BLOCK THAT MAY HAVE TO BE PROGRAMMED
1 - 36	4-03	

OPERATION ← AND → DISPLAY

2. Depress LK1. 
3. Dial 3, then 6, to specify function № 36. 
4. Move setting position (See Note 1). 
5. Input data (0 or 1) with dial pad. Example: When Master No. 10 is set (See Note 2). 
6. Depress MIC key (See Note 3). Repeat steps 4, 5 and 6 to input data up to master No. 50. 
7. Depress MIC key (see Note 4). 
8. Depress SPKR key to go back on line. 

**NOTES:**

1. Dial \* (←), # (→) to move the setting position then input data or function No. 3. Depressing the MIC key enters the data and causes the display to increment to the next master number.



2. Data Table Default value\*

Code	Feature
* 0	No
1	Yes

4. When data is written up to master No. 50, the display increments to the next memory block.

### GENERAL INFORMATION - INTERCOM MASTER NUMBER

This memory block area is used to specify an intercom master number. When a master number is assigned, the subsequent stations in the same tens group are automatically assigned to that hunt group.

## MEMORY BLOCK 1 - 37

### CO/PBX LINE ON HOOK ORIGINATION / ABANDONING (YES/NO)

MEMORY BLOCK BEING PROGRAMMED	MEMORY BLOCK THAT MUST BE PROGRAMMED	MEMORY BLOCK THAT MAY HAVE TO BE PROGRAMMED
1 - 37		

OPERATION ← AND → DISPLAY

2. Depress LK1.

M 1 - 1 2

3. Dial 3, then 7, to specify function № 37.

3 7 - M

4. Input data (0 or 1) with dial pad. Example: Input 1 to select YES (See Notes 1 & 2)

3 7 - 1

5. Depress MIC key (see Note 3).

3 7 - 0

6. Depress SPKR key to go back on line.

2 - 0 2 1 1 - 9 9 8

**NOTES:**

1. Dial \* (←), # (→) to move the setting position then input data or function No.

3 7 - 0

Function No.      Data setting position

3. Depressing the MIC key enters the data and causes the display to increment to the next function number.

2. Data Table      Default value\*

Code	Feature
* 0	No
1	Yes

#### GENERAL INFORMATION - CO/PBX LINE ON HOOK ORIGINATION / ABANDONING (YES/NO)

This memory block area is used to specify whether or not to disconnect an existing CO/PBX call by depressing the CO/PBX line key.

## MEMORY BLOCK 1 - 42 DOOR PHONE CALL AUTOMATIC ANSWER (ALLOW/DENY)

MEMORY BLOCK BEING PROGRAMMED	MEMORY BLOCK THAT MUST BE PROGRAMMED	MEMORY BLOCK THAT MAY HAVE TO BE PROGRAMMED
1 - 42	1-31	1-07
	4-06	

**OPERATION** ← **AND** → **DISPLAY**

2. Depress LK1.



3. Dial 4, then 2, to specify function № 42.



4. Input data (0 or 1) with dial pad. Example: Input 1 to select **ALLOW** (See Notes 1 & 2).



5. Depress MIC key (see Note 3).



6. Depress SPKR key to go back on line.



**NOTES:**

1. Dial \* (←), # (→) to move the setting position then input data or function No.



3. Depressing the MIC key enters the data and causes the display to increment to the next function number.

2. Data Table Default value\*

Code	Feature
* 0	Deny
1	Allow

### GENERAL INFORMATION - DOOR PHONE CALL AUTOMATIC ANSWER (ALLOW/DENY)

This memory block area is used to specify whether or not to allow answering Door Phone calls by simply lifting the handset. (Only ring assigned Key Telephones can be so specified.)

# MEMORY BLOCK 1 - 43 EXTERNAL TONE RING CONTROL

MEMORY BLOCK BEING PROGRAMMED	MEMORY BLOCK THAT MUST BE PROGRAMMED	MEMORY BLOCK THAT MAY HAVE TO BE PROGRAMMED
1 - 43		

OPERATION ← AND → DISPLAY

2. Depress LK1.



3. Dial 4, then 3, to specify function No 43.



4. Input data (0 or 1) with dial pad. Example: When YES is to be specified for night mode.



① Move setting position (See Note 1).

② Input 1 (See Note 2).

Similarly, input data for day mode by steps ① and ②.

5. Depress MIC key (see Note 3).

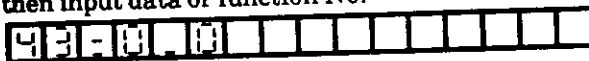


6. Depress SPKR key to go back on line.



**NOTES:**

1. Dial \* (←), # (→) to move the setting position then input data or function No.



Function No.      Data position for night mode  
                                Data position for day mode

3. Depressing the MIC key enters the data and causes the display to increment to the next function number.

2. Data Table      Default value\*

Code	Feature
* 0	No
1	Yes

## GENERAL INFORMATION - EXTERNAL TONE RING CONTROL

This memory block area is used to specify whether or not to ring the extension bell on all incoming CO/PBX calls. Yes or No can be specified for the day and night modes respectively.

## MEMORY BLOCK 1 - 44 TANDEM CONFERENCE LINE ASSIGNMENT

MEMORY BLOCK BEING PROGRAMMED	MEMORY BLOCK THAT MUST BE PROGRAMMED	MEMORY BLOCK THAT MAY HAVE TO BE PROGRAMMED
<b>1 - 44</b>		

**OPERATION** ← AND → **DISPLAY**

2. Depress LK1.



3. Dial 4, then 4, to specify function № 44.



4. Input data with dial pad. Example: Input 33 (See Notes 1 & 2).



5. Depress MIC key (see Note 3).



6. Depress SPKR key to go back on line.



**NOTES:**

1. Dial \* (←), # (→) to move the setting position then input data or function No.



3. Depressing the MIC key enters the data and causes the display to increment to the next function number.

2. Data and keys used to input data

Key	Feature
Dial key	Port No (12-33).
HOLD	Clear data (2 digits)

Default value:  
21

4. If a Key Telephone is connected to the position assigned in this parameter, it will not function (No LEDs or button response).

### GENERAL INFORMATION - TANDEM CONFERENCE LINE ASSIGNMENT

This memory block area is used to assign a hardware port to be used for Tandem Conference.

## MEMORY BLOCK 1 - 50

### AUTOMATIC RELEASE DISCONNECT SIGNAL DETECTION TIME

MEMORY BLOCK BEING PROGRAMMED	MEMORY BLOCK THAT MUST BE PROGRAMMED	MEMORY BLOCK THAT MAY HAVE TO BE PROGRAMMED
<b>1 - 50</b>	<b>3-20</b>	

OPERATION ← AND → DISPLAY

2. Depress LK1.

0 8 2 0 . 2

3. Dial 5, then 0, to specify function № 50.

5 0 . 0

4. Input data (0 - 2) with dial pad. Example: Input 1 for 300 milliseconds (See Notes 1 & 2).

5 0 . 1

5. Depress MIC key (see Note 3).

5 0 . 1

6. Depress SPKR key to go back on line.

2 - 0 2 0 0 - 5 9 9

**NOTES:**

1. Dial \* (←), # (→) to move the setting position then input data or function No.

5 0 . 0

Function No.      Data setting position

3. Depressing the MIC key enters the data and causes the display to increment to the next function number.

2. Data Table      Default value\*

Code	Feature
* 0	150 msec.
1	300 msec.
2	450 msec.

### GENERAL INFORMATION - AUTOMATIC RELEASE DISCONNECT SIGNAL DETECTION TIME

This memory block area is used to enter the duration of the disconnect signal that is sent from the CO/PBX when the outside party hangs the line up on a CO call, after which the call is processed as a disconnect and then the system releases.

## MEMORY BLOCK 1 - 51 1 + DIALING ASSIGNMENT

MEMORY BLOCK BEING PROGRAMMED	MEMORY BLOCK THAT MUST BE PROGRAMMED	MEMORY BLOCK THAT MAY HAVE TO BE PROGRAMMED
1 - 51	5-04	5-01

OPERATION ← AND → DISPLAY

2. Depress LK1.



3. Dial 5, then 1, to specify function № 51.



4. Input data (0 - 1) with dial pad. Example: Input 0 to select *Direct Area* (See Notes 1 & 2).



5. Depress MIC key (see Note 3).



6. Depress SPKR key to go back on line.



**NOTES:**

1. Dial \* (←), # (→) to move the setting position then input data or function No.



Function No.      Data setting position

3. Depressing the MIC key enters the data and causes the display to increment to the next function number.

2. Data Table      Default value \*

Code	Dialing Assignment
0	Direct Area
*1	1 + Area

### GENERAL INFORMATION - 1 + DIALING ASSIGNMENT

This memory block area is used to designate whether 1 + dialing or direct dialing service is required on the CO lines installed.



## MEMORY BLOCK 1 - 52 TOLL RESTRICTION ALLOW TABLE SIZE ASSIGNMENT

MEMORY BLOCK BEING PROGRAMMED	MEMORY BLOCK THAT MUST BE PROGRAMMED	MEMORY BLOCK THAT MAY HAVE TO BE PROGRAMMED
<b>1 - 52</b>	1-55	
	5-04	

**OPERATION** ← AND → **DISPLAY**

2. Depress LK1.

█ 1 - 1 - 2

3. Dial 5, then 2, to specify function No 52.

5 2 - █ 0

4. Input data (00 - 80) with dial pad. Example: Input 25  
(See Notes 1 & 2).

5 2 - 2 5

5. Depress MIC key (see Note 3).

█ 2 -

6. Depress SPKR key to go back on line.

2 - 1 2 1 1 - 5 4 8

**NOTES:**

1. Dial \* (←), # (→) to move the setting position then input data or function No.

5 2 - 0 0

Function No.                      Data setting position

3. Depressing the MIC key enters the data and causes the display to increment to the next function number.

4. If data 00 is set, all entries are automatically assigned as deny entries. If data 80 is set, all entries are automatically assigned as Allow entries.

2. Data Table      Default value: 00

Key	Data
Dial key	00-80

5. The data entered in this parameter designates the last Allow entry.

### GENERAL INFORMATION - TOLL RESTRICTION ALLOW TABLE SIZE ASSIGNMENT

This memory block area is used to specify which entry numbers in the Toll Restriction Tables are Allow or Deny entries. The Toll Override Table can be assigned up to 80 entries. Each entry can consist of 6 digits (3 for area code and 3 for office code).

## MEMORY BLOCK 1 - 53 DIGIT REJECTION ASSIGNMENT

MEMORY BLOCK BEING PROGRAMMED	MEMORY BLOCK THAT MUST BE PROGRAMMED	MEMORY BLOCK THAT MAY HAVE TO BE PROGRAMMED
1 - 53	5-04	

**OPERATION** ← **AND** → **DISPLAY**

2. Depress LK1.



3. Dial 5, then 3, to specify function № 53.



4. Input data with dial pad. Example: Input 6,7,8,9 (See Notes 1 and 2).



5. Depress MIC key (see Note 3).

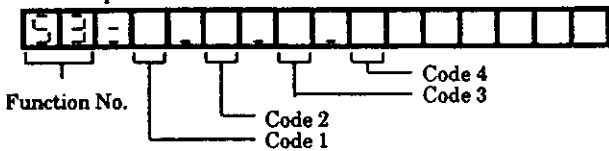


6. Depress SPKR key to go back on line.



**NOTES:**

1. Dial \* (←), # (→) to move the setting position then input data or function No.



3. Depressing the MIC key enters the data and causes the display to increment to the next function number.

2. Data and keys used to input data Default value: NONE

Key	Data
Dial key	Rejection code (4 single digits)
Hold key	Clear 1 data

### GENERAL INFORMATION - DIGIT REJECTION ASSIGNMENT

This memory block area is used to assign up to 4 single digit rejection codes. The rejection code is used to prevent repeated dialing of the same digit from the beginning of the dialing process to defeat the Toll inspection process.

## MEMORY BLOCK 1 - 54 OCC OVERRIDE TABLE ASSIGNMENT

MEMORY BLOCK BEING PROGRAMMED	MEMORY BLOCK THAT MUST BE PROGRAMMED	MEMORY BLOCK THAT MAY HAVE TO BE PROGRAMMED
<b>1 - 54</b>	<b>5-04</b>	

OPERATION ← AND → DISPLAY

2. Depress LK1.

01012

3. Dial 5, then 4, to specify function No 54.

54-0001

4. Input data with dial pad. Example: Input 233 into entry No.1.

54-0001-

ⓐ Move setting position (See Note 1).

54-0001-233

ⓑ Input 233 (See Note 2).

ⓒ Depress MIC key (See Note 3).

54-0002-

Repeat steps ⓐ, ⓑ and ⓒ to input data up to entry No.8.

5. Depress MIC key (see Note 4).

5-0001-

6. Depress SPKR key to go back on line.

2-02 01-540

### NOTES:

1. Dial \* (←), # (→) to move the setting position then input data, entry No., or function No.

54-0001-

Function No.      Entry No. 1-8      Data setting position

3. Depressing the MIC key enters the data and causes the display to increment to the next entry.

2. Data and keys used to input data

Default value:  
NONE

Key	Data
Dial key	OCC code 3 digits
Hold key	Clear 1 data

4. Depressing the MIC key after data is entered to entry 8 causes the display to increment to the next function number.

### GENERAL INFORMATION - OCC OVERRIDE TABLE ASSIGNMENT

This memory block area is used to assign a maximum of 8 OCC codes to an OCC override table. This can force Toll restricted stations to dial long distance calls on less expensive carriers.

## MEMORY BLOCK 1 - 55 TOLL RESTRICTION OVERRIDE TABLE ASSIGNMENT

MEMORY BLOCK BEING PROGRAMMED	MEMORY BLOCK THAT MUST BE PROGRAMMED	MEMORY BLOCK THAT MAY HAVE TO BE PROGRAMMED
1 - 55	5-04	1-52

OPERATION ← AND → DISPLAY

2. Depress LK1.



3. Dial 5, then 5, to specify function № 55.



4. Input data with dial pad. Example: Input 516777 into entry No.01.

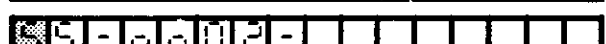


⓪ Move setting position (See Note 1).

⓪ Input 516777 (See Note 2).

⓪ Depress MIC key (See Note 4).

Repeat steps ⓪, ⓪ and ⓪ to input data up to entry No.80.



5. Depress MIC key (see Note 5).



6. Depress SPKR key to go back on line.



**NOTES:**

1. Dial \* (←), # (→) to move the setting position then input data or function No.



Function No.      Entry No. (01 to 80)      Area code (3 digits)      Office code (3 digits)

3. If No Entry is specified, depressing the MIC key enters all digits.

4. Depressing the MIC key enters the data and causes the display to increment to the next entry.

2. Data and keys used to input data      Default value: NONE

Key	Data
Dial key	0-9, No entry (all digits)
Hold key	Clear 1 data (All clear)

5. Depressing the MIC key after data is entered up to 80 causes the display to increment to memory block 1-01.

### GENERAL INFORMATION - TOLL RESTRICTION OVERRIDE TABLE ASSIGNMENT

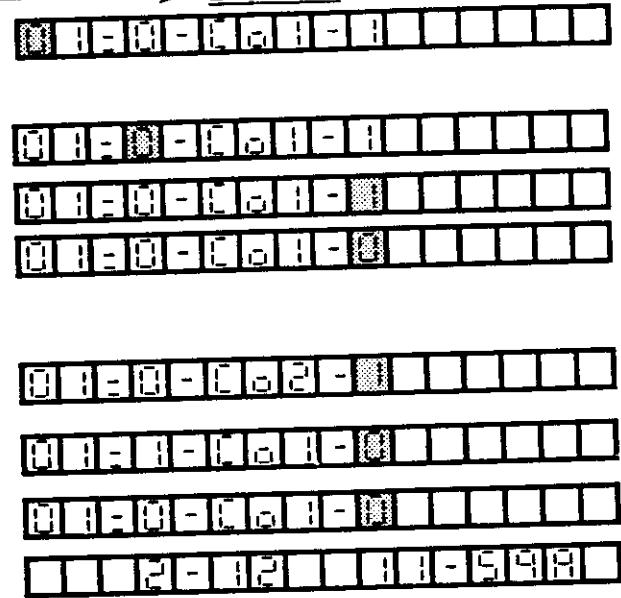
This memory block area provides a table where up to eighty 6 digit numbers can be entered. This table can be separated into an allow and a deny section. When Toll Restriction is applied, the system scans the allow/deny table from its beginning (entry 1) to its end (entry 80). Numbers in the deny section take precedence over numbers in the allow section.

## MEMORY BLOCK 2 - 01 TENANT CO/PBX LINE ACCOMMODATION

MEMORY BLOCK BEING PROGRAMMED	MEMORY BLOCK THAT MUST BE PROGRAMMED	MEMORY BLOCK THAT MAY HAVE TO BE PROGRAMMED
2 - 01	4-01	3-09

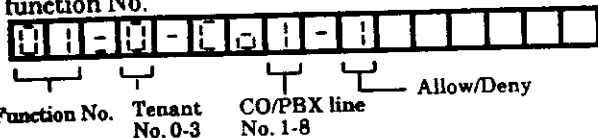
**OPERATION** ← AND → **DISPLAY**

2. Depress LK2.  
**NOTE:** Depressing LK2 automatically brings up Function 01.
3. Dial 0, then 1, to specify function № 01.
4. Input data (0 or 1) with dial pad. Example: When CO No. 1 is not used in Tenant 0.  
  - ⓐ Move setting position (See Note 1).
  - ⓑ Input 0 (See Note 2).
5. Depress MIC key (see Note 3).  
Repeat steps 4 and 5 to input data up to CO No. 8.
6. Depress MIC key (see Note 4).  
Repeat steps 4, 5 and 6 to input data up to Tenant No.3.
7. Depress MIC key (see Note 5).
8. Depress SPKR key to go back on line.



**NOTES:**

1. Dial \* (←), # (→) to move the setting position then input data, tenant No., CO/PBX line No., or function No.



**2. Data Table**

Code	Feature
0	Deny
1	Allow

Default value:  
Tenant 0 accommodates all CO lines.

3. Depressing the MIC key enters the data and causes the display to increment to the next CO number.
4. When data has been entered up to CO No. 8, depressing the MIC key enters the data and the display increments to the next Tenant No.
5. When data is written, up to Tenant No.3, CO No.8, the display is restored to Tenant No. 0, CO No. 1.
6. When a line key is not being used, it should be denied from all tenant groups. This will allow that line key to be used as a feature access key (see Memory Block 3-09).

### GENERAL INFORMATION - TENANT CO/PBX LINE ACCOMMODATION

This memory block area is used to specify which tenants will have access to each CO/PBX line.

## MEMORY BLOCK 3 - 01 to 08 SEIZED SELF CO/PBX NUMBER DISPLAY

MEMORY BLOCK BEING PROGRAMMED	MEMORY BLOCK THAT MUST BE PROGRAMMED	MEMORY BLOCK THAT MAY HAVE TO BE PROGRAMMED
<b>3 - 01 to 08</b>		

**OPERATION** ← AND → **DISPLAY**

2. Depress LK3.  
**NOTE:** Depressing LK3 automatically brings up Function 01.



3. Dial appropriate number to specify function (01 to 08)  
 (See Note 4).



4. Input data with dial pad. Example: Input 0471-64-3864 (See Notes 1 & 2).



5. Depress MIC key (see Note 3).  
 Repeat steps 4 and 5 to input data up to Function No.08.



6. Depress SPKR key to go back on line.



**NOTES:**

1. Dial \* (←), # (→) to move the setting position then input data or function No.



3. Depressing the MIC key enters the data and causes the display to increment to the next function number.

4. Function 01 to 08 correspond to CO/PBX Line 1 to 8 respectively.

2. Data and keys used to input data Default value: NONE

Key	Feature
Dial key	Dial No.
LNR/SPD	Pause (-)
HOLD	Space

### GENERAL INFORMATION - SEIZED SELF CO/PBX NUMBER DISPLAY

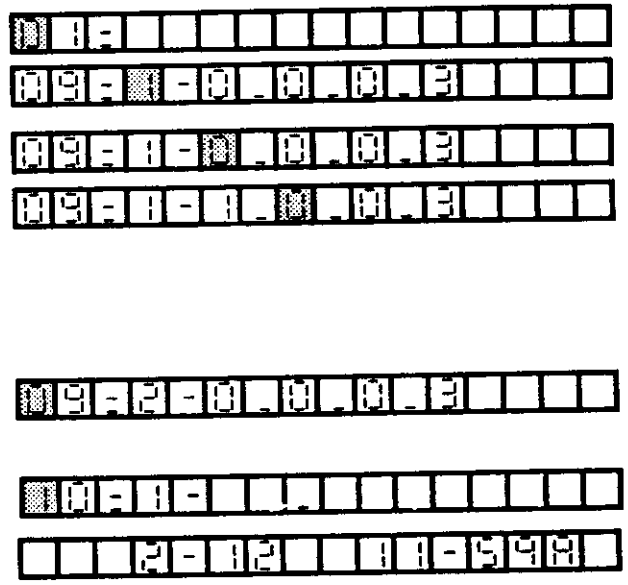
This memory block area is used to enter the CO/PBX numbers to be displayed on Key Telephones upon seizure of CO/PBX lines.

## MEMORY BLOCK 3 - 09 CO/PBX LINE STATUS SELECTION

MEMORY BLOCK BEING PROGRAMMED	MEMORY BLOCK THAT MUST BE PROGRAMMED	MEMORY BLOCK THAT MAY HAVE TO BE PROGRAMMED
<b>3 - 09</b>		1-05, 1-12,
		1-21, 1-26,
		2-01, 4-02, 5-01

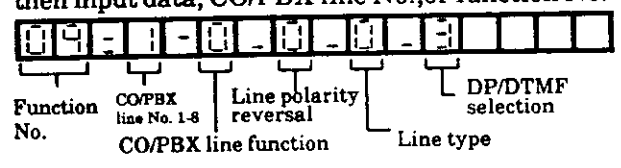
**OPERATION** ← AND → **DISPLAY**

2. Depress LK3.
3. Dial 0, then 9, to specify function No 09.
4. Input data with dial pad. Example: The CO/PBX line function on CO 1 is set for *ANSWERING* only.  
 ⓐ Move setting position (See Note 1).  
 ⓑ Input 1 (See Note 2).  
 Repeat steps ⓐ and ⓑ to specify other items.
5. Depress MIC key (see Note 3).  
Repeat steps 4 and 5, and 6 to input data up to CO No. 8.
6. Depress MIC key (see Note 4).
7. Depress SPKR key to go back on line.



**NOTES:**

1. Dial \* (←), # (→) to move the setting position then input data, CO/PBX line No., or function No.



2. Data Table Default value\*

Code	CO/PBX line function	Line polarity reversal	Line type	DP/DTMF selection
0	* Origination & answering	* No	* CO	Not Connected
1	Answering	Yes	PBX	DP (10 PPS)
2	—	—	—	DP (20 PPS)
3	—	—	—	* DTMF

3. Depressing the MIC key enters the data and causes the display to increment to the next CO number.
4. When data has been entered up to CO No. 8, depressing the MIC key enters the data and the display increments to the next function number.
5. If the CO/PBX line is assigned to **Not Connected** by DP/DTMF selection item, the corresponding CO/PBX line key can be used as a programmable **Feature Access** key (see Memory Block 2-01). If both CO/PBX lines in the line pair (Nos. 1-2, 3-4, 5-6, 7-8) are assigned as DP, the pulse rate can not be assigned separate of each other. The Pulse rate for the even numbered line is determined by the assignment of the odd numbered line.








### GENERAL INFORMATION - CO/PBX LINE STATUS SELECTION

This memory block area is used to specify line status for each CO/PBX line. CO/PBX Line Status Selection covers Origination and Answering, Line polarity reversal (Yes/No), CO/PBX line type and DP/DTMF.


## MEMORY BLOCK 3 - 20 AUTOMATIC RELEASE SELECTION

MEMORY BLOCK BEING PROGRAMMED	MEMORY BLOCK THAT MUST BE PROGRAMMED	MEMORY BLOCK THAT MAY HAVE TO BE PROGRAMMED
<b>3 - 20</b>		<b>1-50</b>

**OPERATION** ← **AND** → **DISPLAY**

- |                                                                                                                                                                                                                                                                                                                                                                                                                                                                                              |                                                                                                                                                                                                                                                                                                                                                                                                                                                                                                                                                                                                                                               |
|----------------------------------------------------------------------------------------------------------------------------------------------------------------------------------------------------------------------------------------------------------------------------------------------------------------------------------------------------------------------------------------------------------------------------------------------------------------------------------------------|-----------------------------------------------------------------------------------------------------------------------------------------------------------------------------------------------------------------------------------------------------------------------------------------------------------------------------------------------------------------------------------------------------------------------------------------------------------------------------------------------------------------------------------------------------------------------------------------------------------------------------------------------|
| <p>2. Depress LK3.</p> <p>3. Depress HOLD key.</p> <p>4. Dial 2, then 0, to specify function № 20.</p> <p>5. Input data (0 or 1) with dial pad. Example: Specify <i>ALLOW</i> (Automatic Release).<br/>         ⓐ Move setting positon (See Note 1).<br/>         ⓑ Input 1 (See Note 2).</p> <p>6. Depress MIC key (see Note 3).<br/>         Repeat steps 4 and 5 to input data up to CO No.08.</p> <p>7. Depress MIC key (see Note 4).</p> <p>8. Depress SPKR key to go back on line.</p> | <br><br><br><br><br><br><br><br><br><br><br> |
|----------------------------------------------------------------------------------------------------------------------------------------------------------------------------------------------------------------------------------------------------------------------------------------------------------------------------------------------------------------------------------------------------------------------------------------------------------------------------------------------|-----------------------------------------------------------------------------------------------------------------------------------------------------------------------------------------------------------------------------------------------------------------------------------------------------------------------------------------------------------------------------------------------------------------------------------------------------------------------------------------------------------------------------------------------------------------------------------------------------------------------------------------------|

**NOTES:**

- | <p>1. Dial * (←), # (→) to move the setting position then input data, CO/PBX line No., or function No.</p> <div style="margin-left: 20px;">  </div>                                                                                                                                                                                                                     | <p>3. Depressing the MIC key enters the data and causes the display to increment to the next CO number.</p> |         |     |      |   |       |                                                                                                               |
|------------------------------------------------------------------------------------------------------------------------------------------------------------------------------------------------------------------------------------------------------------------------------------------------------------------------------------------------------------------------------------------------------------------------------------------------------------|-------------------------------------------------------------------------------------------------------------|---------|-----|------|---|-------|---------------------------------------------------------------------------------------------------------------|
| <p>2. Data Table      Default value *</p> <table border="1" style="margin-left: 20px; border-collapse: collapse;"> <thead> <tr> <th style="text-align: center;">Code</th> <th style="text-align: center;">Feature</th> </tr> </thead> <tbody> <tr> <td style="text-align: center;">* 0</td> <td style="text-align: center;">Deny</td> </tr> <tr> <td style="text-align: center;">1</td> <td style="text-align: center;">Allow</td> </tr> </tbody> </table> | Code                                                                                                        | Feature | * 0 | Deny | 1 | Allow | <p>4. When data is written up to CO No. 8, the display returns to function number 01 (Memory Block 3-01).</p> |
| Code                                                                                                                                                                                                                                                                                                                                                                                                                                                       | Feature                                                                                                     |         |     |      |   |       |                                                                                                               |
| * 0                                                                                                                                                                                                                                                                                                                                                                                                                                                        | Deny                                                                                                        |         |     |      |   |       |                                                                                                               |
| 1                                                                                                                                                                                                                                                                                                                                                                                                                                                          | Allow                                                                                                       |         |     |      |   |       |                                                                                                               |

### GENERAL INFORMATION - AUTOMATIC RELEASE SELECTION

This memory block area is used to specify Allow or Deny Automatic Release for each CO line, to disconnect or not, when a disconnect signal is received from the distant station. If Automatic Release is Denied, the line will not be disconnected when a disconnect signal is received.

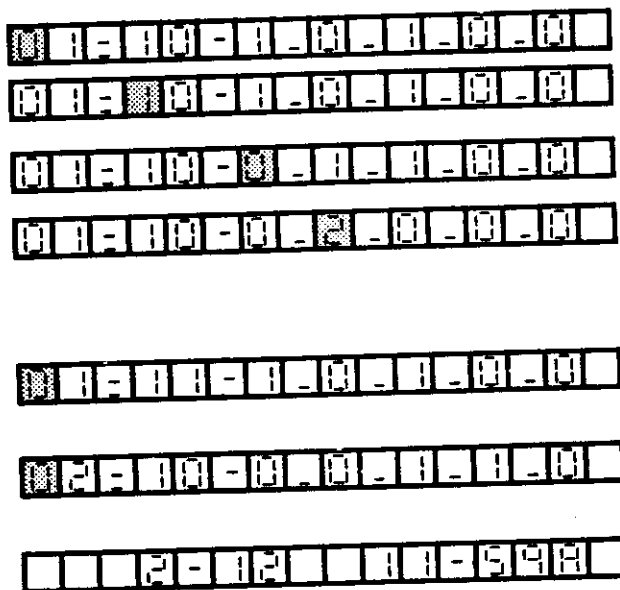


## MEMORY BLOCK 4 - 01 TELEPHONE STATUS SELECTION I

MEMORY BLOCK BEING PROGRAMMED	MEMORY BLOCK THAT MUST BE PROGRAMMED	MEMORY BLOCK THAT MAY HAVE TO BE PROGRAMMED
4 - 01	1-17	2-01

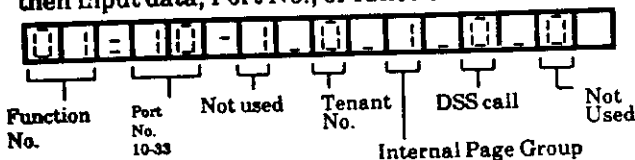
**OPERATION** ← **AND** → **DISPLAY**

2. Depress LK4.
3. Dial 0, then 1, to specify function № 01.
4. Input data with dial pad. Example: Tenant 0
  - ⓐ Move setting position (See Note 1).
  - ⓑ Input 2 (See Note 2).
 Similarly, input other items by steps ⓐ and ⓑ.
5. Depress MIC key (see Note 3).  
Repeat steps 4 and 5, to input data up to Port No. 33.
6. Depress MIC key (see Note 4).
7. Depress SPKR key to go back on line.



**NOTES:**

1. Dial \* (←), # (→) to move the setting position then input data, Port No., or function No.



3. Depressing the MIC key enters the data and causes the display to increment to the next Port number.

**2. Data Table**

Default value\*

Code	Tenant No.	Internal Page Group	DSS Call
0	* Tenant 0	Not Used	* DSS 1
1	Tenant 1	* Group 1	DSS 2
2	Tenant 2	Group 2	
3	Tenant 3	Group 3	

4. When data has been entered up to Port No. 33, depressing the MIC key enters the data and the display increments to the next function number.

### GENERAL INFORMATION - TELEPHONE STATUS SELECTION I

This memory block area is used to enter the following status data for each Key Telephone: Tenant Number, Internal Page Assignment, DSS 1/DSS 2 Call. Tenant number is used to assign a station to a call pick group and is also used for Trunk Access. A station can only access trunks assigned to its Tenant Group. A station dialing 0 on intercom will be connected to the assigned DSS call number.

## MEMORY BLOCK 4 - 02 TELEPHONE STATUS SELECTION II

MEMORY BLOCK BEING PROGRAMMED	MEMORY BLOCK THAT MUST BE PROGRAMMED	MEMORY BLOCK THAT MAY HAVE TO BE PROGRAMMED
4 - 02	3-09,	1-20, 1-26,
	5-02, 5-03	5-01,

OPERATION ← AND → DISPLAY

2. Depress LK4.



3. Dial 0, then 2, to specify function No 02.



4. Input data (0 or 1) with dial pad. Example: Specify three minute alarm ALLOW on Port No. 10.



- ① Move setting position (See Note 1).
  - ② Input 1 (See Note 2).
- Similarly, input other items by steps ① and ②.

5. Depress MIC key (see Note 3).  
 Repeat steps 4 and 5 to input data up to Port No.33.



6. Depress MIC key (see Note 4).

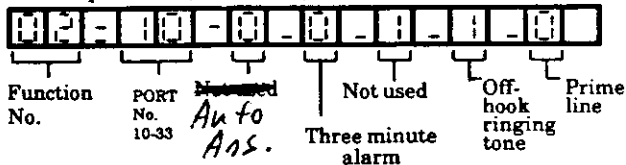


7. Depress SPKR key to go back on line.



**NOTES:**

1. Dial \* (←), # (→) to move the setting position then input data, Port No., or function No.



2. Data Table Default value \*

		Three minute alarm	
* 0		Deny	
1		Allow	
† Off-hook ringing tone		Prime line	
0	Deny	* 0	Deny
1	Allow	1	Allow

† Default value for Off- hook ringing tone: Allowed on Port No. 10, 11 only.

3. Depressing the MIC key enters the data and causes the display to increment to the next Port number.

4. When data is written up to Port No. 33, the display increments to the next function number.

### GENERAL INFORMATION - TELEPHONE STATUS SELECTION II

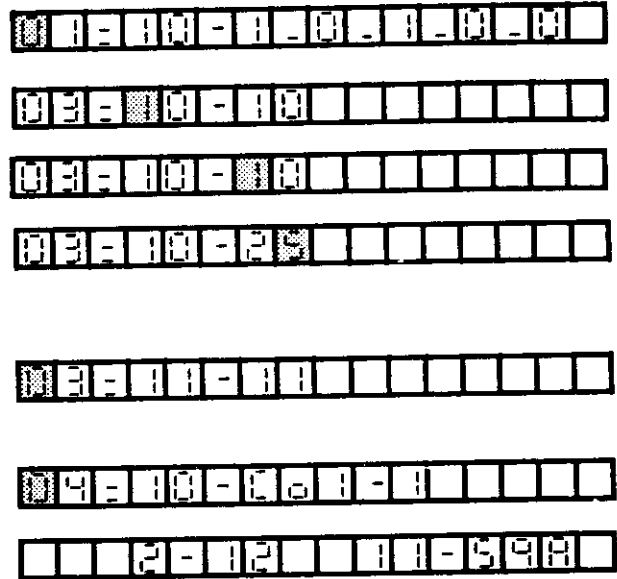
This memory block area is used to enter the following status data for each telephone: Three Minute Alarm (Allow/Deny), Off-Hook Ring (Allow/Deny), and Prime Line (Allow/Deny) Selection.

## MEMORY BLOCK 4 - 03 EXTENSION NUMBER ASSIGNMENT

MEMORY BLOCK BEING PROGRAMMED	MEMORY BLOCK THAT MUST BE PROGRAMMED	MEMORY BLOCK THAT MAY HAVE TO BE PROGRAMMED
<b>4 - 03</b>		

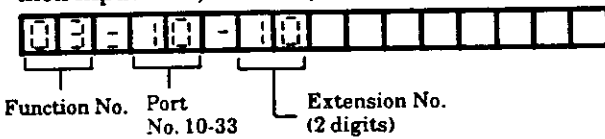
**OPERATION** ← **AND** → **DISPLAY**

2. Depress LK4.
3. Dial 0, then 3, to specify function № 03.
4. Move setting position (See Note 1).
5. Input data with dial pad. Example: To set Port 10 as EXT 25, input 25 (See Note 2).
6. Depress MIC key (see Note 3).  
Repeat steps 4, 5 and 6 to input data up to Port No. 33.
7. Depress MIC key (see Note 4).
8. Depress SPKR key to go back on line.



**NOTES:**

1. Dial \* (←), # (→) to move the setting position then input data, Port No., or function No.



3. Depressing the MIC key enters the data and causes the display to increment to the next Port number.

2. Data and keys used to input data.

Key	Feature
Dial key	Ext. No. (10-59)

Default value:  
Port No. = Extension No.

4. When data has been entered up to Port No. 33, depressing the MIC key enters the data and the display increments to the next function number.

### GENERAL INFORMATION - EXTENSION NUMBER ASSIGNMENT

This memory block area is used to change an extension number of a telephone.

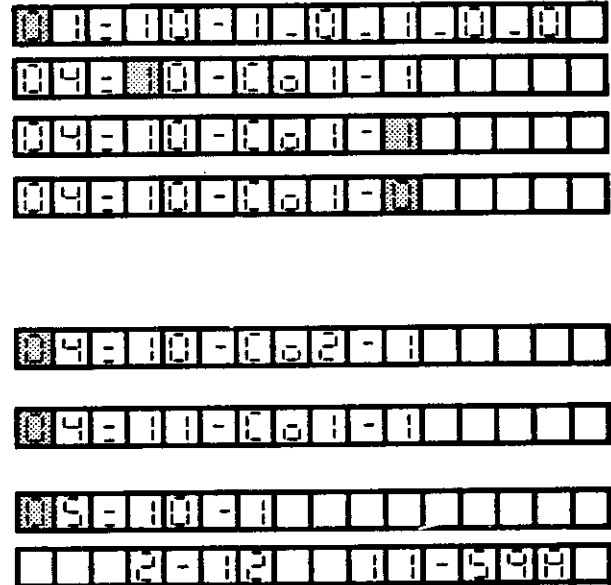
## MEMORY BLOCK 4 - 04

### AUTOMATIC CO/PBX LINE SEIZURE/PRIME LINE ASSIGNMENT

MEMORY BLOCK BEING PROGRAMMED	MEMORY BLOCK THAT MUST BE PROGRAMMED	MEMORY BLOCK THAT MAY HAVE TO BE PROGRAMMED
<b>4 - 04</b>		1-26,
		4-02

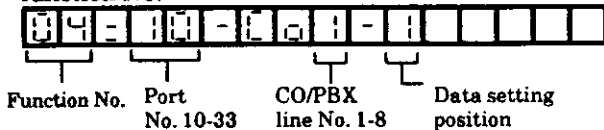
**OPERATION** ← AND → **DISPLAY**

2. Depress LK4.
  3. Dial 0, then 4, to specify function № 04.
  4. Input data (0 or 1) with dial pad. Example: For Port 10, CO 1 is denied automatically seize on outgoing call.
- ① Move setting position (See Note 1).  
 ② Input 0 (See Note 2).
5. Depress MIC key (see Note 3).  
Repeat steps 4 and 5 to input data up to CO No.08.
  6. Depress MIC key (see Note 4).  
Repeat steps 4, 5 and 6 to input data up to Port No. 33.
  7. Depress MIC key (see Note 5).
  8. Depress SPKR key to go back on line.



**NOTES:**

1. Dial \* (←), # (→) to move the setting position then input data, CO/PBX line No., Port No., or function No.



2. Data Table Default value\*

Code	Feature
0	Deny
* 1	Allow

3. Depressing the MIC key enters the data and causes the display to increment to the next CO number.
4. Depressing the MIC key when CO 8 is displayed, enters the data and causes the display to increment to the next Port number.
5. When data is written up to Port No. 33, and CO/PBX line No. 8, the display increments to the next function number.
6. If a prime line is being assigned, all lines with the exception of the prime line must be assigned data 0.

### GENERAL INFORMATION - AUTOMATIC CO/PBX LINE SEIZURE/ PRIME LINE ASSIGNMENT

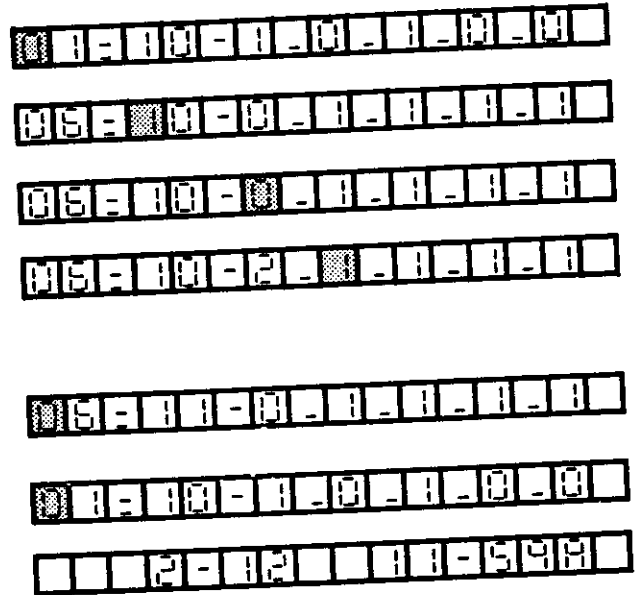
This memory block area is used to specify whether or not to automatically seize an idle CO/PBX line when a trunk access code is dialed on an intercom line. This memory block is also used to assign the CO/PBX line in which a station user will access when going off hook (Prime line). If the line is busy, the station user will receive intercom dial tone upon going off-hook, another CO/PBX line can then be selected. A station user will not be able to automatically seize an idle line if the system is registered as a KF system

## MEMORY BLOCK 4 - 06 RINGING TONE ASSIGNMENT

MEMORY BLOCK BEING PROGRAMMED	MEMORY BLOCK THAT MUST BE PROGRAMMED	MEMORY BLOCK THAT MAY HAVE TO BE PROGRAMMED
<b>4 - 06</b>	1-31,	1-07
	5-02,	1-42
	5-03	

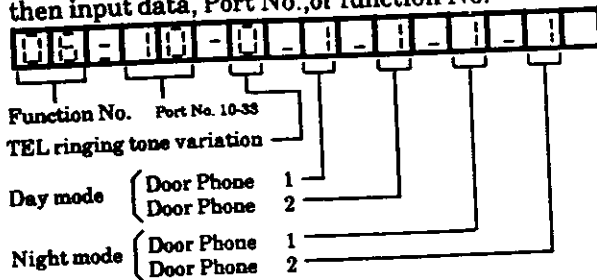
OPERATION ← AND → DISPLAY

2. Depress LK4.
3. Dial 0, then 6, to specify function № 06.
4. Input data with dial pad. Example: When ringing tone on Port 10 is set *HIGH*.
  - ⓐ Move setting position (See Note 1).
  - ⓑ Input 2 (See Note 2).
 For Door Phone ringing tone, also input data by steps ⓐ and ⓑ.
5. Depress MIC key (see Note 3).  
Repeat steps 4 and 5 to input data up to Port No. 33.
6. Depress MIC key (see Note 4).
7. Depress SPKR key to go back on line.



**NOTES:**

1. Dial \* (←), # (→) to move the setting position then input data, Port No., or function No.



Code	Door Phone ringing tone
0	Deny
1	Allow

Default value:  
Only telephones on Port No. 10 and 11 ring on all Door Phone calls.

2. Data Table Default value\*

Code	TEL ringing tone
* 0	L (Low)
1	M (Medium)
2	H (High)

3. Depressing the MIC key enters the data and causes the display to increment to the next Port number.
4. When data has been entered up to Port No. 33, depressing the MIC key enters the data and the display increments to memory block 4-01.

### GENERAL INFORMATION - RINGING TONE ASSIGNMENT

This memory block area is used to specify the type of ringing tone to sound on Key Telephones upon access on a CO/PBX line, and to assign Key Telephones to ring upon access by a Door Phone (Maximum. Six Stations).

## MEMORY BLOCK 5 - 01 FEATURE ASSIGNMENT (MENU PROGRAMMING)

MEMORY BLOCK BEING PROGRAMMED	MEMORY BLOCK THAT MUST BE PROGRAMMED	MEMORY BLOCK THAT MAY HAVE TO BE PROGRAMMED
<b>5 - 01</b>		

**OPERATION** ← AND → **DISPLAY**

2. Depress LK9 (see Note 1). [MIC LED illuminates.]

F1-000 FEA E W P E

3. Dial #. [MIC LED goes out.]

F1-    FEA E W P E

4. Input pattern No. with dial pad. Example: Input pattern No. 123. (see Note 2)

F1-1    FEA E W P E

① Depress dial key 1.

② Depress dial key 2.

③ Depress dial key 3.

Resume operation from step 3 to correct pattern No.

F1-12    FEA E W P E

F1-123    FEA E W P E

5. Depress MIC key (see Note 3).  
 [MIC LED and CO LED (red) illuminate.]

6. Depress SPKR key to go back on line.

2-12 11-594

**NOTES:**

1. Depress LK9, display changes as follows:

F1-000 FEA E W P E

Function No.

Pattern No.

2. Specified status is shown on CO LEDs.

LK1(7)	LK2(6)	LK3(5)	LK4(4)	<input type="checkbox"/> OFF: 0
LK5(3)	LK6(2)	LK7(1)	LK8	<input checked="" type="checkbox"/> ON: 1

(Pattern No: 123)

3. Select Pattern No. having the optimum desired combination of values for each item below (see Pattern Table on the following pages) and input pattern numbers. Default Pattern = 000

Item to be set Data value (0/1) (off/on as shown in Pattern Table)

- |                                     |               |
|-------------------------------------|---------------|
| (1) Type of CO                      | CO/PBX        |
| (2) Off-hook Ringing System wide    | No/Yes        |
| (3) Ringing Line Preference         | No/Yes        |
| (4) Toll Restriction                | Direct/1+     |
| (5) System Speed Dial Toll Override | No/Yes        |
| (6) Pause Timer                     | 3.5sec/1.0sec |
| (7) Hold Recall Time                | 2min/No limit |

4. When off-hook ring setting is yes Memory Blocks 1-20 and 4-02 are enabled. Memory Block 4-02 for off-hook ring is enabled for all ports.

5. Pattern No. is always 000 when this memory block is accessed.

### GENERAL INFORMATION - FEATURE ASSIGNMENT (MENU PROGRAMMING)

This memory block area is used to select the pattern of desired values for the following items from the Pattern Table. Type of CO (CO/PBX line mode), Off-hook Ringing System wide (TEL mode), Ring Line Preference (TEL mode), Toll Restriction (SYS mode), System Speed Dial Toll Override (SYS mode), Pause Timer (SYS mode), Hold Recall Time (SYS mode).

**PATTERN TABLE**

PATTERN NUMBER	TYPE of CO (CO/PBX LINE MODE)		OFF-HOOK RINGING SYS. WIDE		RINGING LINE PREFERENCE (TEL. MODE)		TOLL RESTRICTION (SYS. MODE)		SYS. SPD TOLL OVERRIDE (SYS. MODE)		PAUSE TIMER (SYS. MODE)		HOLD RECALL TIME (SYS. MODE)	
	PBX	CO	YES	NO	YES	NO	NON 1+	1+	YES	NO	1.0SEC	3.5SEC	NO LIMIT	2MIN
	ON	OFF	ON	OFF	ON	OFF	ON	OFF	ON	OFF	ON	OFF	ON	OFF
000		✓		✓		✓		✓		✓		✓		✓
001		✓		✓		✓		✓		✓		✓	✓	
002		✓		✓		✓		✓		✓	✓		✓	
003		✓		✓		✓		✓		✓	✓		✓	
004		✓		✓		✓		✓	✓			✓	✓	
005		✓		✓		✓		✓	✓			✓	✓	
006		✓		✓		✓		✓	✓		✓		✓	
007		✓		✓		✓		✓	✓		✓		✓	
008		✓		✓		✓	✓			✓		✓	✓	
009		✓		✓		✓	✓			✓		✓	✓	
010		✓		✓		✓	✓			✓	✓		✓	
011		✓		✓		✓	✓			✓	✓		✓	
012		✓		✓		✓	✓		✓			✓	✓	
013		✓		✓		✓	✓		✓			✓	✓	
014		✓		✓		✓	✓		✓		✓		✓	
015		✓		✓		✓	✓		✓		✓		✓	
016		✓		✓	✓			✓		✓		✓	✓	
017		✓		✓	✓			✓		✓		✓	✓	
018		✓		✓	✓			✓		✓	✓		✓	
019		✓		✓	✓			✓		✓	✓		✓	
020		✓		✓	✓			✓	✓			✓	✓	
021		✓		✓	✓			✓	✓			✓	✓	
022		✓		✓	✓			✓	✓		✓		✓	
023		✓		✓	✓			✓	✓		✓		✓	
024		✓		✓	✓		✓			✓		✓	✓	
025		✓		✓	✓		✓			✓		✓	✓	
026		✓		✓	✓		✓			✓	✓		✓	
027		✓		✓	✓		✓			✓	✓		✓	
028		✓		✓	✓		✓		✓			✓	✓	
029		✓		✓	✓		✓		✓			✓	✓	
030		✓		✓	✓		✓		✓		✓		✓	
031		✓		✓	✓		✓		✓		✓		✓	
032		✓	✓			✓		✓		✓		✓		✓

PATTERN TABLE (CONTINUED)

PATTERN NUMBER	TYPE of CO (CO/PBX LINE MODE)		OFF-HOOK RINGING SYS. WIDE		RINGING LINE PREFERENCE (TEL. MODE)		TOLL RESTRICTION (SYS. MODE)		SYS. SPD TOLL OVERRIDE (SYS. MODE)		PAUSE TIMER (SYS. MODE)		HOLD RECALL TIME (SYS. MODE)	
	PBX	CO	YES	NO	YES	NO	NON 1+	1+	YES	NO	1.0SEC	1.5SEC	NO LIMIT	2MIN
	ON	OFF	ON	OFF	ON	OFF	ON	OFF	ON	OFF	ON	OFF	ON	OFF
033		✓	✓			✓		✓		✓		✓	✓	
034		✓	✓			✓		✓		✓	✓			✓
035		✓	✓			✓		✓		✓	✓		✓	
036		✓	✓			✓		✓	✓			✓		✓
037		✓	✓			✓		✓	✓			✓	✓	
038		✓	✓			✓		✓	✓		✓			✓
039		✓	✓			✓		✓	✓		✓		✓	
040		✓	✓			✓	✓			✓		✓		✓
041		✓	✓			✓	✓			✓		✓	✓	
042		✓	✓			✓	✓			✓	✓			✓
043		✓	✓			✓	✓			✓	✓		✓	
044		✓	✓			✓	✓		✓			✓		✓
045		✓	✓			✓	✓		✓			✓	✓	
046		✓	✓			✓	✓		✓		✓			✓
047		✓	✓			✓	✓		✓		✓		✓	
048		✓	✓		✓			✓		✓		✓		✓
049		✓	✓		✓			✓		✓		✓	✓	
050		✓	✓		✓			✓		✓	✓			✓
051		✓	✓		✓			✓		✓	✓		✓	
052		✓	✓		✓			✓	✓			✓		✓
053		✓	✓		✓			✓	✓			✓	✓	
054		✓	✓		✓			✓	✓		✓			✓
055		✓	✓		✓			✓	✓		✓		✓	
056		✓	✓		✓		✓			✓		✓		✓
057		✓	✓		✓		✓			✓		✓	✓	
058		✓	✓		✓		✓			✓	✓			✓
059		✓	✓		✓		✓			✓	✓		✓	
060		✓	✓		✓		✓		✓			✓		✓
061		✓	✓		✓		✓		✓			✓	✓	
062		✓	✓		✓		✓		✓		✓			✓
063		✓	✓		✓		✓		✓		✓		✓	
064	✓			✓		✓		✓		✓		✓		✓
065	✓			✓		✓		✓		✓		✓	✓	
066	✓			✓		✓		✓		✓	✓			✓



**PATTERN TABLE (CONTINUED)**

PATTERN NUMBER	TYPE of CO (CO/PBX LINE MODE)		OFF-HOOK RINGING SYS. WIDE		RINGING LINE PREFERENCE (TEL. MODE)		TOLL RESTRICTION (SYS. MODE)		SYS. SPD TOLL OVERRIDE (SYS. MODE)		PAUSE TIMER (SYS. MODE)		HOLD RECALL TIME (SYS. MODE)	
	PBX	CO	YES	NO	YES	NO	NON 1+	1+	YES	NO	1.0SEC	3.5SEC	NO LIMIT	2MIN
	ON	OFF	ON	OFF	ON	OFF	ON	OFF	ON	OFF	ON	OFF	ON	OFF
067	✓			✓		✓		✓		✓	✓		✓	
068	✓			✓		✓		✓	✓			✓		✓
069	✓			✓		✓		✓	✓			✓		✓
070	✓			✓		✓		✓	✓		✓			✓
071	✓			✓		✓		✓	✓		✓			✓
072	✓			✓		✓	✓			✓		✓		✓
073	✓			✓		✓	✓			✓		✓		✓
074	✓			✓		✓	✓			✓	✓			✓
075	✓			✓		✓	✓			✓	✓			✓
076	✓			✓		✓	✓		✓			✓		✓
077	✓			✓		✓	✓		✓			✓		✓
078	✓			✓		✓	✓		✓		✓			✓
079	✓			✓		✓	✓		✓		✓			✓
080	✓			✓	✓			✓		✓		✓		✓
081	✓			✓	✓			✓		✓		✓		✓
082	✓			✓	✓			✓		✓	✓			✓
083	✓			✓	✓			✓		✓	✓			✓
084	✓			✓	✓			✓	✓			✓		✓
085	✓			✓	✓			✓	✓			✓		✓
086	✓			✓	✓			✓	✓		✓			✓
087	✓			✓	✓			✓	✓		✓			✓
088	✓			✓	✓		✓			✓		✓		✓
089	✓			✓	✓		✓			✓		✓		✓
090	✓			✓	✓		✓			✓	✓			✓
091	✓			✓	✓		✓			✓	✓			✓
092	✓			✓	✓		✓		✓			✓		✓
093	✓			✓	✓		✓		✓			✓		✓
094	✓			✓	✓		✓		✓		✓			✓
095	✓			✓	✓		✓		✓		✓			✓
096	✓		✓			✓		✓		✓		✓		✓
097	✓		✓			✓		✓		✓		✓		✓
098	✓		✓			✓		✓		✓	✓			✓
099	✓		✓			✓		✓		✓	✓			✓
100	✓		✓			✓		✓	✓			✓		✓

PATTERN TABLE (CONTINUED)

PATTERN NUMBER	TYPE of CO (CO/PBX LINE MODE)		OFF-HOOK RINGING SYS. WIDE		RINGING LINE PREFERENCE (TEL. MODE)		TOLL RESTRICTION (SYS. MODE)		SYS. SPD TOLL OVERRIDE (SYS. MODE)		PAUSE TIMER (SYS. MODE)		HOLD RECALL TIME (SYS. MODE)	
	PBX	CO	YES	NO	YES	NO	NON 1+	1+	YES	NO	1.0SEC	3.5SEC	NO LIMIT	2MIN
	ON	OFF	ON	OFF	ON	OFF	ON	OFF	ON	OFF	ON	OFF	ON	OFF
101	✓		✓			✓		✓			✓		✓	
102	✓		✓			✓		✓		✓				✓
103	✓		✓			✓		✓		✓			✓	
104	✓		✓			✓	✓		✓		✓		✓	
105	✓		✓			✓	✓		✓		✓		✓	
106	✓		✓			✓	✓		✓		✓		✓	
107	✓		✓			✓	✓		✓		✓		✓	
108	✓		✓			✓	✓		✓		✓		✓	
109	✓		✓			✓	✓		✓		✓		✓	
110	✓		✓			✓	✓		✓		✓		✓	
111	✓		✓			✓	✓		✓		✓		✓	
112	✓		✓		✓			✓		✓		✓		✓
113	✓		✓		✓			✓		✓		✓		✓
114	✓		✓		✓			✓		✓		✓		✓
115	✓		✓		✓			✓		✓		✓		✓
116	✓		✓		✓			✓	✓		✓		✓	
117	✓		✓		✓			✓	✓		✓		✓	
118	✓		✓		✓			✓	✓		✓		✓	
119	✓		✓		✓			✓	✓		✓		✓	
120	✓		✓		✓		✓		✓		✓		✓	
121	✓		✓		✓		✓		✓		✓		✓	
122	✓		✓		✓		✓		✓		✓		✓	
123	✓		✓		✓		✓		✓		✓		✓	
124	✓		✓		✓		✓		✓		✓		✓	
125	✓		✓		✓		✓		✓		✓		✓	
126	✓		✓		✓		✓		✓		✓		✓	
127	✓		✓		✓		✓		✓		✓		✓	

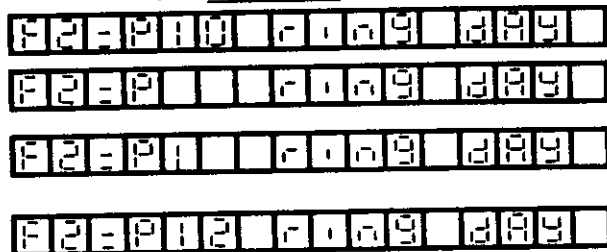
## MEMORY BLOCK 5 - 02

### RING ASSIGNMENT-DAY (MENU PROGRAMMING)

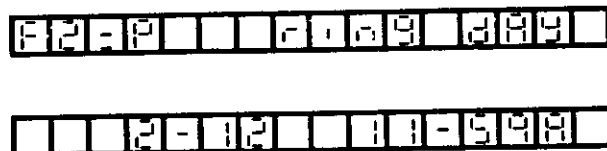
MEMORY BLOCK BEING PROGRAMMED	MEMORY BLOCK THAT MUST BE PROGRAMMED	MEMORY BLOCK THAT MAY HAVE TO BE PROGRAMMED
<b>5 - 02</b>		

**OPERATION** ← AND → **DISPLAY**

2. Depress LK10 key (see Note 1). [MIC LED illuminates.]
3. Depress # key. [MIC LED goes out.]
4. Input Port No. from dial key. Example: Input PORT No.12.  
 Ⓞ Depress dial key 1, 2 (See note 2).  
 [Each CO/PBX line assigned to ring is indicated by the CO/PBX LEDs (LED is on).]

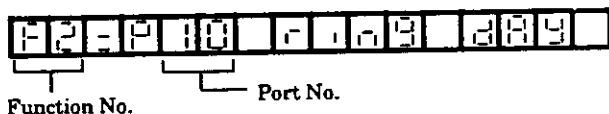


5. Depress Line Keys to specify Ring Assignment (day) for each CO/PBX line (Status is inverted by depressing the Line Key).
6. Depress MIC key (see Notes 3 & 4). [MIC LED goes on] Repeat steps 5 and 6 or 3 through 6 to specify other telephones.
7. Depress SPKR key to go back on line.



**NOTES:**

1. Depress LK10 key and the input display appears.



3. Depressing the MIC key enters yes/no of Ring Assignment (day), and the status of the next Port No. is shown by CO LEDs (red).

2. The visual indication at each CO/PBX line button (1-8) identifies if CO/PBX ring is enabled. Each button depression changes the ring assignment.

LED OFF = Not assigned to ring  
LED ON = Ring assigned

4. Default: Port 10, 11 ring on all incoming CO/PBX calls.

**GENERAL INFORMATION - RING ASSIGNMENT-DAY (MENU PROGRAMMING)**

This memory block area is used to specify CO/PBX day mode ring assignment for each station.

## MEMORY BLOCK 5 - 03 RING ASSIGNMENT-NIGHT (MENU PROGRAMMING)

MEMORY BLOCK BEING PROGRAMMED	MEMORY BLOCK THAT MUST BE PROGRAMMED	MEMORY BLOCK THAT MAY HAVE TO BE PROGRAMMED
<b>5 - 03</b>		

**OPERATION** ← AND → **DISPLAY**

2. Depress LK11 (see Note 1). [MIC LED illuminates] F3-P10 2079 7E
3. Depress #. [MIC LED goes out] F3-P 2079 7E
4. Input Port No. with dial pad. Example: Input PORT No. 20.  
 Depress dial key 2, 0 (See Note 2).  
 [Each CO/PBX line assigned to ring is indicated by the CO/PBX LEDs (LED is On).] F3-P2 2079 7E  
F3-P20 2079 7E
5. Depress the Line Keys to specify Ring Assignment (night) for each CO/PBX line. (Status is inverted by depressing the Line Key).
6. Depress MIC key (see Notes 3 & 4). [MIC LED goes on] Repeat steps 5 and 6, or 3 through 6 to specify other telephones. F3-E21 2079 7E
7. Depress SPKR key to go back on line. 2-12 11-599

**NOTES:**

1. Depress LK11, display changes as follows:  


F3-P	10	2079	7E
------	----	------	----

  
 Function No.                      Port No.
 

 3. Depressing the MIC key enters the Ring Assignment (night), and the status of the next PORT No. is shown by CO LEDs (red).
2. The visual indication at each CO/PBX Line Key (1-8) identifies if CO/PBX ring is enabled. Each key depression changes the ring assignment.
4. Default: PORT 10,11 ring on all incoming CO/PBX calls.

LED OFF = Not assigned to ring  
 LED ON = Ring assigned

### GENERAL INFORMATION - RING ASSIGNMENT - NIGHT (MENU PROGRAMMING)

This memory block area is used to specify CO/PBX Night Mode ring assignment for each Key Telephone and each line.

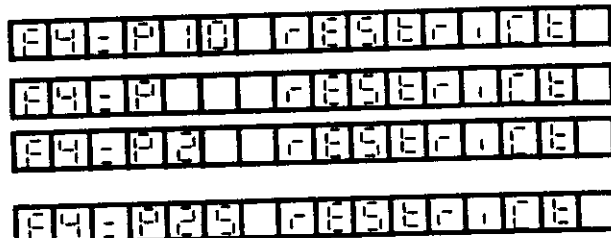
## MEMORY BLOCK 5 - 04

### NON/TOLL/OUTGOING RESTRICTION (MENU PROGRAMMING)

MEMORY BLOCK BEING PROGRAMMED	MEMORY BLOCK THAT MUST BE PROGRAMMED	MEMORY BLOCK THAT MAY HAVE TO BE PROGRAMMED
<b>5 - 04</b>		1-15

OPERATION ← AND → DISPLAY

2. Depress LK12 (see Note 1). [MIC LED illuminates]
3. Depress # key. [MIC LED goes out]
4. Input Port No. with dial pad. Example: Input PORT No. 25.  
Depress dial key 2, 5.  
[Specified status of each CO/PBX line is shown by CO/PBX LEDs (red)]



5. Depress Line Keys to specify Restriction for each CO/PBX line (See Note 2).

6. Depress MIC key (see Note 4).[MIC LED goes on] Repeat steps 5 and 6, or 3 through 6 to specify other telephones.



7. Depress SPKR key to go back on line.



**NOTES:**

1. Dial LK12 and displays changes as follows:



2. Visual indication at each CO/PBX Line Key (1-8) identifies the type of restriction for that line. Each key depression changes restriction status of associated CO/PBX line.

LED OFF = No restrictions  
LED ON = Toll Restriction (depress once)  
LED Flashing = Outgoing Restriction (depress twice).

Depress a third time to return to idle condition.

3. Depressing the MIC key specified Non/ Toll/ Outgoing and the status of the next Port No. is shown by CO/PBX LEDs (red).

4. Default: No Restrictions are assigned to any Key Telephone.

### GENERAL INFORMATION - NON/TOLL/OUTGOING RESTRICTION (MENU PROGRAMMING)

This memory block area is used to specify three types of restrictions - No Restriction, Outgoing Restriction, and Toll Restriction - for each telephone and each CO/PBX line.

## MEMORY BLOCK 6-A SPEED DIALING CLEAR (SYSTEM)

MEMORY BLOCK BEING PROGRAMMED	MEMORY BLOCK THAT MUST BE PROGRAMMED	MEMORY BLOCK THAT MAY HAVE TO BE PROGRAMMED
<b>6 - A</b>		

OPERATION ←
AND
→ DISPLAY

2. Depress FNC key.

C	L	E	A	r						
---	---	---	---	---	--	--	--	--	--	--

3. Depress LNR/SPD key.

4. Depress dial key 1.

5. Depress \* key.

9	9	5		S	P	D		C	L	E	A	r		
---	---	---	--	---	---	---	--	---	---	---	---	---	--	--

6. Depress MIC key (see Note 1).

C	L	E	A	r						
---	---	---	---	---	--	--	--	--	--	--

7. Depress SPKR key to go back on line.

		2	-	1	2			1	1	-	5	9	A	
--	--	---	---	---	---	--	--	---	---	---	---	---	---	--



**NOTES:**

1. Depressing the MIC key clears the speed dialing (system).

**GENERAL INFORMATION - SPEED DIALING CLEAR (SYSTEM)**

This operation is performed to clear all the system speed dial numbers.

**MEMORY BLOCK 6 - B  
 SPEED DIALING CLEAR (TELEPHONE)**

MEMORY BLOCK BEING PROGRAMMED	MEMORY BLOCK THAT MUST BE PROGRAMMED	MEMORY BLOCK THAT MAY HAVE TO BE PROGRAMMED
<b>6 - B</b>		

**OPERATION** ← AND → **DISPLAY**

2. Depress FNC key.

CLEAR

3. Depress LNR/SPD key.

4. Depress dial key 3.

5. Depress # key.

SER SPD CLEAR

6. Depress MIC key (see Note 1).

CLEAR

7. Depress SPKR key to go back on line.

2-12 11-598



**NOTES:**

1. Depressing the MIC key clears all Key Telephones the station speed dialing.

**GENERAL INFORMATION - SPEED DIALING CLEAR (TELEPHONE)**  
 This operation is performed to clear all the station speed dial numbers assigned to all Key Telephones.

## MEMORY BLOCK 6-C ROM VERSION CONFIRMATION

MEMORY BLOCK BEING PROGRAMMED	MEMORY BLOCK THAT MUST BE PROGRAMMED	MEMORY BLOCK THAT MAY HAVE TO BE PROGRAMMED
<b>6 - C</b>		

**OPERATION** ← **AND** → **DISPLAY**

2. Depress CNF key (see Note 1).

00-CPW-1.00 0

3. Depress MIC key (see Note 2).

00CPW

4. Depress MIC key (see Note 2).

02

5. Depress MIC key (see Note 3).

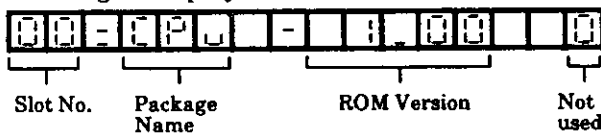
03-5.27-1-00

6. Depress SPKR key to go back on line.

2-02 11-548

**NOTES:**

1. Meaning of Display Items



3. ROM version in the SMDR unit is displayed.

2. Whether or not the EXK-Z KTU is installed on the MBD(412)-Z KTU.

Display signifies the following.

Blank: No installation

OP0: EXK-Z

OP1: EXK-Z

### GENERAL INFORMATION - ROM VERSION CONFIRMATION

The ROM version can be confirmed without taking the package from the slot.



## SECTION 350 FUNCTION TIMER CHART

TIMER	MEMORY BLOCK	DEFINITION	DEFAULT VALUE
Hook Flash Time	1-01	Duration of CO/PBX hook flash when the RECALL key is depressed.	Key Telephone: 0.6sec.
Hold Recall Time	1-02	The length of time a held line will wait to provide recall indications.	2 min.
Paging Time	1-03	Duration of internal zone paging, or external zone paging.	90 sec.
Pause Time and Interdigit Time	1-05	Duration of waiting time between digits, no dial signal, and duration between dial signals (DP).	Pause Time: 3.5 sec. Interdigit Time: 800msec.
Door Phone Display Time	1-07	Duration of displaying accessed Door Phone on an assigned Key Telephone.	10 sec.
Ring Transfer Recall Time	1-08	Duration from transfer of ringing tone to Recall Tone.	1 min.
Automatic Callback Time	1-09	Duration from a callback to its release	No limit
Automatic Redial Time	1-10	Ring and waiting time to access a busy station.	Ring Time: 60 sec. Waiting Time: 120 sec. Repeat: 5 times
Elapse Call and SMDR Start Timer	1-12	The time in which the elapse call timer is displayed on an ETZ-16D-1 Key Telephone, also the time in which the SMDR will wait to print a call record.	10 sec.
DTMF Signal Sending Time	1-21	Duration of DTMF signal sending.	100 msec.
Automatic Release Disconnection Signal Detection Time	1-50	Duration of disconnection signal detection.	150 msec.

## SECTION 360 TOLL RESTRICTION

### 360.1 General

To provide dialing restrictions to individual stations and on a CO line basis, a method of code restriction has been designed into the Electra 8/24 system.

There are three types of dialing restriction: Nonrestriction, Toll Restriction, and Outgoing Restriction. Any of these can be specified using Memory Block 5-04.

To register Toll Restriction, the following system basis must be specified using Memory Blocks 1-51 through 1-55.

- 1-51 1 + Dialing Assignment
- 1-52 Toll Restriction Allow Table Size Assignment
- 1-53 Digit Rejection Assignment
- 1-54 OCCs Override Table Assignment
- 1-55 Toll Restriction Override Table Assignment

This section will fully explain this procedure. It is recommended that before attempting to program any restrictions that this section be fully reviewed.

### 360.2 Non/Toll/Outgoing Restriction (See Memory Block 5-04, Section 340 of this manual.)

This memory block area is used to specify any of three types of dialing restriction - Non Restriction, Outgoing Restriction, and Toll Restriction - for each telephone and each CO line.

1. Non Restriction: No restriction on any outgoing calls.
2. Outgoing Restriction: Outgoing calls on CO lines are restricted.
  - A. In the automatic selection of CO lines by Automatic Idle CO/PBX Line Seizure, Speed Dialing, etc., CO lines under Outgoing Restriction will not be seized.
  - B. Incoming calls can be answered, held calls can be reanswered, and calls can be transferred.
  - C. If **RECALL** key is depressed while talking on a CO line under Outgoing Restriction, that CO line will be disconnected.
  - D. If a dial key is depressed while talking on a CO line under Outgoing Restriction, that CO line will be disconnected.
3. Toll Restriction: Toll calls are restricted.

### 360.3 Toll Restriction (See Memory Block 1-51 to 1-55, Section 340 of this manual)

These memory block areas are used to restrict the dialing of toll calls according to the Toll Restriction Algorithm shown in figure 1. The following assignments are necessary to restrict toll calls.

1. 1 + Dialing Assignment (See Memory Block 1-51)

This area of the program is used to select a Toll Restriction format to suit the installation Site Requirements.

In some locations it is necessary to dial a 1 before dialing a foreign area code and local exchanges have 3 digit office codes with the same format as area codes. If 1 + Dialing is entered into the program, calls beginning with 1 (calls to foreign area codes) will be denied when the station is Toll Restricted on that line, but local dialing will be allowed. In other locations, it is not necessary to dial a 1 before dialing a foreign area code; in this case 1 + Dialing should be removed from the program. Memory Block 1-51 is used to select which type of inspection process is desired. The default value is that 1 + Dialing is assigned.

2. Digit Rejection Assignment (See Memory Block 1-53)

This area of the program is used to prevent repeated dialing of the same digit from the beginning of the dialing process to defeat the Toll Restriction Inspection Process. This ability has been entered into the program so that when an exchange ignores a particular digit or digits, if they are the first digits dialed and merely continues to offer dial tone, the Toll Inspection Process will still be valid. A toll restricted station dialing a number listed in the digit rejection table will be dropped from the CO/PBX line and receive error tone. Up to 4 separate digits can be entered. The default value is no assignment.

3. OCCs Override Table Assignment (See Memory Block 1-54)

This area of the program is used to specify OCCs (Other Common Carriers) to be accessed.

- A. OCC can be accessed by dialing 10 after seizing a CO line.
- B. If an OCC code (3 digit) is not dialed within 10 seconds after OCC access, the CO line is disconnected.
- C. Up to 8 OCC codes can be programmed per system. (OCC Override Table)

- D. If an unprogrammed OCC code is dialed, the CO line is released.
  - E. Toll Restriction is in effect as in ordinary dialing after OCC access (10XXX).
  - F. The default value is no assignment in all tables.
4. Toll Restriction Allow Table Size and Override table Assignment (See Memory Block 1-52, 1-55)

These areas of the program are used to restrict toll calls by area code and office code.

- A. Override Table: 6 digits  $\times$  80
- B. Register area code (3 digit) and office code (3 digit) in the 6 digit line of Override Table.
- C. Override Tables can be classified into Allow Tables and Deny Tables by Table Size Assignment through Memory Block 1-52.
- D. If a number not registered in Allow Override Table is dialed, the CO line is disconnected.
- E. Any digit (0 to 9) and X (0 to 9) can be registered in the Override Table.

- F. Outgoing calls can be allowed or denied by an office code for the same area depending on combination of Allow Table and Deny Table.

Example 1:

Restricting a certain office code only for the same area

Allow Table: 214 XXX

Deny Table: 214 333

Example 2:

Allowing a certain office code only for the same area

Allow Table: 214 333

Deny Table: - - (Not registered)

- G. If a number dialed is not specified in the Override Table, the number dialed will be denied.
- H. Only the digits dialed after the PBX access code on a PBX line is restricted by Toll Restriction.
- I. Dialing # or \* is restricted only when sending DTMF signals on CO/PBX lines.

### TOLL RESTRICTION ALGORITHM

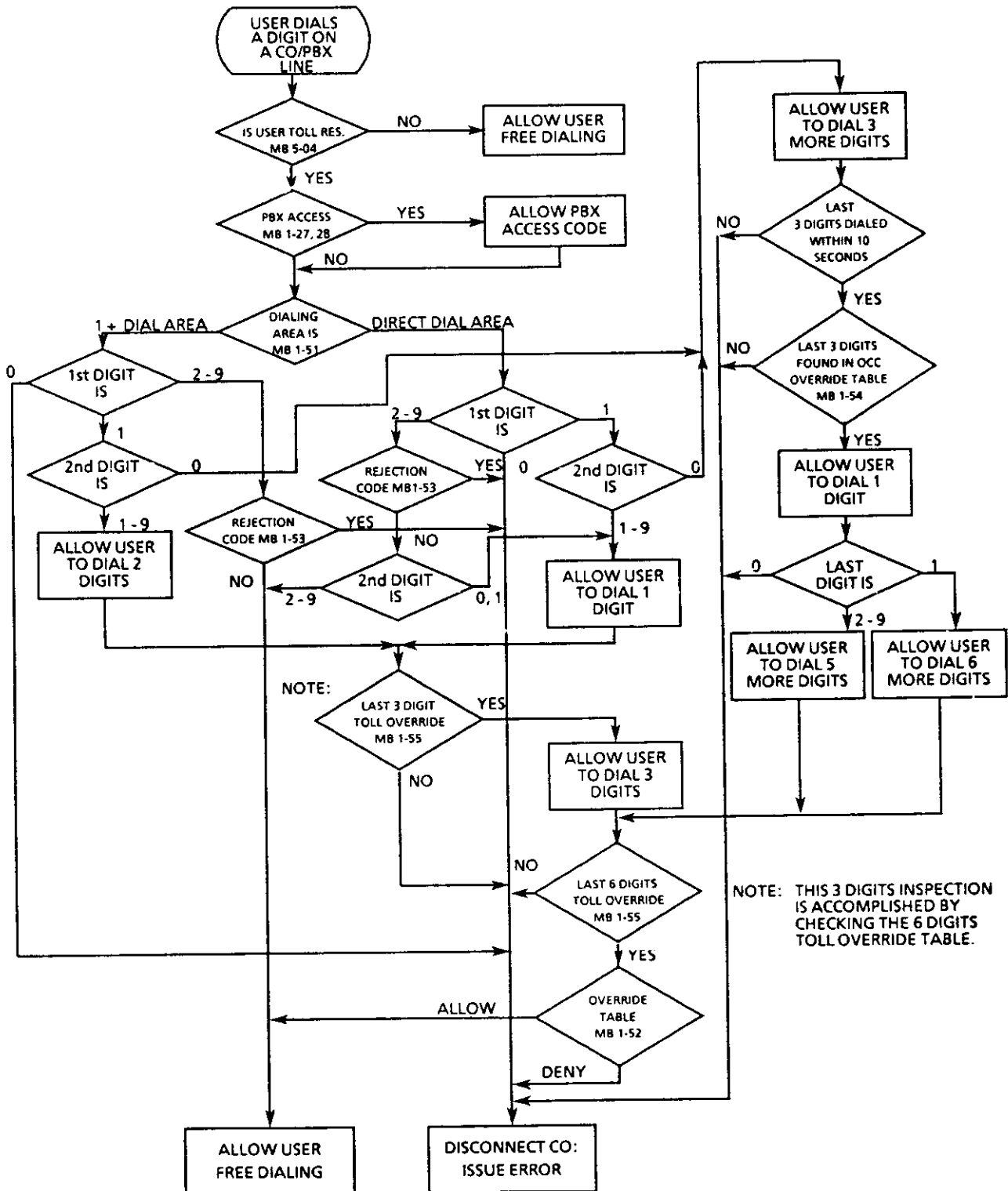


Figure 1 Electra 8/24 Toll Denial

**This page intentionally left blank.**

## SECTION 370 JOB SPECIFICATION SHEETS

This section consists of samples of Job Specification Sheets that when filled out contain all the system programming values and configuration information.

During the initial stages of system planning, the job specification sheets are necessary for collecting information to accurately configure the installation of the ELECTRA 8/24 Electronic Key Telephone System. The customer information, as collected by the salesperson (or installation supervisor), is recorded onto the specification sheets. Samples of these sheets are arranged in the logical order of the memory blocks to make the system programming as efficient as possible.

The first group of sheets are used for entering the System mode functions. The second group for assigning the Tenant mode functions. The third group for programming the CO/PBX line mode functions. The fourth group for entering the Telephone mode functions, and the fifth for the Menu (Pattern) selection mode.

The first page of each job sheet includes a brief description of each column and possible entries. After initial installation, job sheets must be kept up to date and left on site to provide technicians with the necessary information required when servicing the system. A duplicate copy should also be kept in the servicing office customer file.

# JOB SPECIFICATION SHEETS TABLE OF CONTENTS

MEMORY BLOCK	FUNCTION	PAGE	MEMORY BLOCK	FUNCTION	PAGE
1-01	<i>System Mode</i>		2-01	<i>Tenant Mode</i>	
02	Hook Flash Time Selection	300-74		Tenant CO/PBX Line Accommodation	300-88
03	Hold Recall Time Selection				
05	Paging Time Out Selection		3-01-08	<i>CO/PBX Line Mode</i>	
07	Pause Time and Interdigit Time Selection			Seized Self CO/PBX Number Display	300-90
08	Door Phone Display Time Selection		09	CO/PBX Line Status Selection	
09	Ring Transfer Recall Time Selection		20	Automatic Release Selection	
10	Automatic Callback Time Selection				
12	Automatic Redial Time Selection		4-01	<i>Telephone Mode</i>	
13	Elapsed Call and SMDR Start Timer Selection	300-76		Telephone Status Selection - I	300-92
14	Intercom Call Signal Tone/Voice Selection		02	Telephone Status Selection - II	
15	Station BGM Connection (Allow/Deny)		03	Extension Number Assignment	
16	Cancellation of System Speed Dial Toll Override		04	Automatic CO/PBX Line Seizure/Prime Line Assignment	300-94
17	System Speed Dialing Confirmation Telephone		06	Ring Tone Assignment	
18	DSS/BLF Console Assignment				
19	Ring Tone Transfer Time Display Switching (12h/24h)		5-01	<i>Menu Selection Mode</i>	
20	Off-hook Ringing Tone			Feature Assignment	300-96
21	DTMF Digit Duration Selection	300-78	02	Ring Assignment- Day	
23	Handset Receiving Volume		03	Ring Assignment- Night	
			04	Non/Toll/Outgoing Restriction	300-98
24	Privacy Override Tone on CO/PBX Line (Allow/Deny)				
25	External Speaker (Connected/Not Connected)				
26	Line Selection Codes				
27	PBX Access Code Assignment - I				
28	PBX Access Code Assignment - II				
29	Privacy Override Assignment				
30	Private Line Assignment	300-80			
31	Door Phone Assignment (Installed/Not Installed)				
32	Door Lock Release (Allow/Deny)				
34	SMDR Print Format				
36	Intercom Master Number				
37	CO/PBX Line On Hook Origination/Abandoning (Yes/No)				
42	Door Phone Call Automatic Answer (Allow/Deny)	300-82			
43	External Tone Ring Control				
44	Tandem Conference Line Assignment				
50	Automatic Release Disconnection Signal Detection Time				
51	1 + Dialing Assignment	300-84			
53	Digit Rejection Assignment				
54	OCC Override Table Assignment				
52	Toll Restriction Allow Table Size Assignment	300-86			
54	Toll Restriction Override Table Assignment				

**JOB SPECIFICATION INSTRUCTIONS  
 FOR  
 MEMORY BLOCKS 1-01 ~ 1-10 ASSIGNMENT OF SYSTEM MODE FUNCTIONS**

MEMORY BLOCK	FUNCTION (AREA)	DEFAULT	NEW	DESCRIPTION	ENTRY
1-01	HOOK FLASH TIME	KST (sec) 0.6	KST (sec)	TIMING OF CO/PBX HOOK FLASH FROM THE RECALL KEY OF KEY TELEPHONE TO THE CO	0.4, 0.6, 1.0, 1.5 (sec)
1-02	HOLD RECALL TIME	2 min.		DURATION FROM THE HOLD OF A CO/PBX CALL UNTIL AN ALARM SOUND IS GENERATED	1, 2, 4, NO LIMIT (min)
1-03	PAGING TIME	90 sec.		DURATION OF ALL KEY TELEPHONES PAGING, GROUP PAGING OR EXTERNAL SPEAKER PAGING	90, 120, NO LIMIT (sec)
1-05	PAUSE TIME AND INTERDIGIT TIME	PAUSE (sec) 3.5 MINIMUM PAUSE (msec) 800	MINIMUM PAUSE (msec)	DURATION OF SENDING NO DIAL SIGNAL TO CO/PBX LINE	PULSE: 1.0, 3.5 (sec)
1-07	DOOR PHONE DISPLAY TIME	10 sec.		MINIMUM INTERVAL BETWEEN DIAL SIGNALS IN DP DIALING	MINIMUM PAUSE: 700/550, 800 (msec)
1-08	RINGING TRANSFER TONE RECALL TIME	1 min.		DURATION IN WHICH THE ACCESSED DOOR PHONE IS DISPLAYED ON A KEY TELEPHONE WHICH IS ASSIGNED TO RING	10, 30, 60, 90 (sec)
1-09	AUTOMATIC CALLBACK TIME	NO LIMIT	MIN	DURATION FROM RINGING TRANSFER TONE TO RECALL SOUNDING	0.5, 1, 2, 4 (min)
1-10	AUTOMATIC REDIAL TIME	RINGING TIME (sec)	RINGING TIME (sec)	DURATION FROM A CALLBACK TO ITS RELEASE	30, 60, 90 NO LIMIT
		WAITING TIME (sec)	RINGING TIME (sec)	NUMBER OF DIALINGS TO BE REPEATED, RINGING TIME AND WAITING TIME	
		REPEAT	REPEAT		

RINGING TIME (sec)	60	60	40	30
WAITING TIME (sec)		120	90	60
REPEAT	5	5	5	5



**MEMORY BLOCKS 1-01 ~ 1-10 ASSIGNMENT OF SYSTEM MODE FUNCTIONS**

MEMORY BLOCK	FUNCTION (AREA)	DEFAULT		NEW	
		KST (sec)		KST (sec)	
1-01	HOOK FLASH TIME	0.6			
1-02	HOLD RECALL TIME	2 min			
1-03	PAGING TIME	90 sec			
1-05	PAUSE TIME INTERDIGIT TIME	PAUSE (sec)	MINIMUM PAUSE (msec)	PAUSE (sec)	MINIMUM PAUSE (msec)
		3.5	800		
1-07	DOOR PHONE DISPLAY TIME	10 sec			
1-08	RINGING TRANSFER TONE RECALL TIME	1 min			
1-09	AUTOMATIC CALLBACK TIME	NO LIMIT		MIN.	
1-10	AUTOMATIC REDIAL TIME	RINGING TIME (sec)	60	RINGING TIME (sec)	
		WAITING TIME (sec)	120	RINGING TIME (sec)	
		REPEAT	5	REPEAT	

**JOB SPECIFICATION INSTRUCTIONS  
 FOR  
 MEMORY BLOCKS 1 - 12 ~ 1 - 20 ASSIGNMENT OF SYSTEM MODE FUNCTIONS**

MEMORY BLOCK	FUNCTION (AREA)	DEFAULT	NEW	DESCRIPTION	ENTRY
1-12	ELAPSED CALL AND SMDR START TIMER	10 sec		DURATION FROM WHEN THE ELAPSED CALL TIMER WILL START, ALSO USED FOR SMDR START TIMER	10, 20, 30 (sec)
1-13	INTERCOM CALL SIGNAL TONE/VOICE	VOICE		SELECTION OF SIGNAL; TONE OR VOICE FOR INTERCOM CALL	VOICE OR SIGNAL TONE
1-14	STATION BGM CONNECTION	DENY		ALLOW/DENY BGM CONNECTION	ALLOW OR DENY
1-15	CANCELLATION OF SYSTEM SPEED DIAL TOLL OVERRIDE	NOT CANCELED		RESTRICT OR NOT RESTRICT KEY TELEPHONES USING SYSTEM SPEED DIAL NUMBERS	CANCEL OR NOT
1-16	SYSTEM SPEED DIALING CONFIRMATION KEY TELEPHONE	PORT 10, 11 ONLY		SELECTION OF PORT 10, 11 OR ALL TELEPHONES IN CONFIRMING SYSTEM SPEED DIAL NUMBERS	PORT NO. 10, 11 OR ALL TELEPHONES
1-17	DSS/BLF CONSOLE	DSS1	PORT NO. 10	SETTING OF DSS/BLF CONSOLES TO PORTS 10 AND 11	PORT NO. (10-33)
		DSS2	PORT NO. 11		
1-18	RINGING TONE TRANSFER	ALLOW		ALLOW/DENY FOR RINGING TONE TRANSFER	ALLOW OR DENY
1-19	TIME DISPLAY SWITCHING (12 HOUR/24 HOUR)	12 HOUR SYSTEM		SPECIFY EITHER 12 HOURS OR 24 HOURS FOR TIME DISPLAY	12 HOUR SYSTEM OR 24 HOUR SYSTEM
1-20	OFF-HOOK RINGING TONE	ALLOW		ALLOW/DENY OF RINGING TONE WHILE TALKING	YES OR NO

**JOB SPECIFICATION INSTRUCTIONS  
 FOR  
 MEMORY BLOCKS 1-21 ~ 1-29 ASSIGNMENT OF SYSTEM MODE FUNCTIONS**

MEMORY BLOCK	FUNCTION (AREA)	DEFAULT	NEW	
1-21	DTMF DIGIT DURATION	100 msec		
1-23	HANDSET RECEIVING VOLUME	DOWN		
1-24	PRIVACY OVERRIDE TONE ON CO/PBX LINE	DENY		
1-25	EXTERNAL SPEAKER	CONNECTED		
1-26	LINE SELECTION CODES	CODE 9	CO LINE	CODE 9
		CODE 80	PBX	CODE 80
		CODE 88	—	CODE 88
		PRIME LINE	CO LINE	PRIME LINE
1-27	PBX ACCESS CODE ASSIGNMENT I	8 - (PAUSE)		
1-28	PBX ACCESS CODE ASSIGNMENT II	9 - (PAUSE)		
1-29	PRIVACY OVERRIDE ASSIGNMENT	NOT ASSIGNED		

DESCRIPTION	ENTRY
DURATION OF SENDING DTMF SIGNALS	100, 300 (msec)
VOLUME INCREASE IS DOWN OR REMAINS UP WHEN YOU HANG UP	DOWN (RESET) OR UP (NOT RESET) WHEN YOU HANG UP
YES/NO FOR A TONE TO A CALL ON A CO/PBX LINE, WHEN PRIVACY OVERRIDE IS ENABLED	ALLOW OR DENY
EXTERNAL SPEAKERS ARE CONNECTED OR NOT CONNECTED,	CONNECTED/NOT CONNECTED (SPEAKER 1, 2)
SPECIFY LINE TO BE SEIZED WHEN CODES 9, 80, 88 ARE DIALED AND CO/PBX LINE TYPE ASSIGNED FOR PRIME LINE	NONE, CO LINE, PBX
SPECIFY THE CODE TO SEIZE CO LINE CONNECTED TO PBX	PBX TIE LINE OUTGOING CODE MAX. 6 DIGITS
SPECIFY THE CODE TO SEIZE CO LINE ACCOMMODATED IN PBX	PBX CO LINE OUTGOING CODE MAX. 6 DIGITS
SPECIFY THE KEY TELEPHONES ALLOWED TO OVERRIDE CALLS ON CO/PBX LINES	PORT NO. (10-33); MAX. 8 TELEPHONES

MEMORY BLOCKS 1 - 12 ~ 1 - 20 ASSIGNMENT OF SYSTEM MODE FUNCTIONS

MEMORY BLOCK	FUNCTION (AREA)	DEFAULT	NEW
1-12	ELAPSED CALL AND SMDR START TIMER	10 sec	
1-13	INTERCOM CALL SIGNAL TONE/VOICE	VOICE	
1-14	STATION BGM CONNECTION	DENY	
1-15	CANCEL OF SYSTEM SPEED DIALING TOLL OVERRIDE	NOT CANCELED	
1-16	SYSTEM SPEED DIALING CONFIRMATION KEY TELEPHONE	TEL 10, 11 ONLY	
1-17	DSS/BLF CONSOLE	DSS1	PORT NO. 10
		DSS2	PORT NO. 11
1-18	RINGING TRANSFER TONE	ALLOW	
1-19	TIME DISPLAY SWITCHING (12 HOUR/24 HOUR)	12 HOUR SYSTEM	
1-20	OFF-HOOK RINGING	ALLOW	

**MEMORY BLOCKS 1-21 ~ 1-29 ASSIGNMENT OF SYSTEM MODE FUNCTIONS**

MEMORY BLOCK	FUNCTION (AREA)	DEFAULT	NEW
1-21	DTMF DIGIT DURATION	100 msec	
1-23	HANDSET RECEIVING VOLUME	DOWN	
1-24	PRIVACY OVERRIDE TONE ON CO/PBX LINE	DENY	
1-25	EXTERNAL SPEAKER	CONNECTED	
1-26	LINE SELECTION CODES	CODE 9	CODE 9
		CODE 80	PBX
		CODE 88	---
		PRIME LINE	CO LINE
1-27	PBX ACCESS CODE ASSIGNMENT I	8 - (PAUSE)	
1-28	PBX ACCESS CODE ASSIGNMENT II	9 - (PAUSE)	
1-29	PRIVACY OVERRIDE ASSIGNMENT	NOT ASSIGNED	

**JOB SPECIFICATION INSTRUCTIONS  
 FOR  
 MEMORY BLOCKS 1 - 30 ~ 1 - 37 ASSIGNMENT OF SYSTEM MODE FUNCTIONS**

MEMORY BLOCK	FUNCTION (AREA)	DEFAULT	NEW	DESCRIPTION	ENTRY
1-30	PRIVATE LINE	NOT ASSIGNED		ASSIGN A CO/PBX LINE TO A KEY TELEPHONE FOR EXCLUSIVE USE	CO NO. (1-8) AND PORT NO. (10-33): 1 CO LINE- 2 STATIONS x 2
1-31	DOOR PHONE	INSTALLED <small>Door Phone 1 &amp; 2</small>		SPECIFY YES/NO IF A DOOR PHONE IS INSTALLED	INSTALLED/NOT INSTALLED (DOOR PHONE 1, 2)
1-32	DOOR LOCK RELEASE	BOTH RELAYS ALLOWED		SPECIFY DOOR LOCK OR RELEASE	ALLOW OR DENY (DOOR LOCK 1, 2)
1-34	SMDR PRINT FORMAT	ALL DIGITS		SPECIFY ALL DIGITS OR MASK LOWER 4 DIGITS OF DIALED TELEPHONES IN PRINTING	ALL (DIGITS) OR MASK (LOWER 4 DIGITS)
1-36	INTERCOM MASTER NUMBER	NOT ASSIGNED		SPECIFY MASTER NUMBER USED OR NOT USED	NO OR NUMBER (MASTER NUMBER: 10 - 20 - 30 - 40 - 50)
1-37	CO/PBX LINE ON HOOK ORIGINATION/ ABANDONING	NO		YES/NO OF ON HOOK ORIGINATION/ABANDONING OF A CO/PBX CALL	YES OR NO

MEMORY BLOCKS 1-30 ~ 1-37 ASSIGNMENT OF SYSTEM MODE FUNCTIONS

MEMORY BLOCK	FUNCTION (AREA)	DEFAULT	NEW
1-30	PRIVATE LINE	NOT ASSIGNED	
1-31	DOOR PHONE	INSTALLED Door Phone 1 & 2	
1-32	DOOR LOCK RELEASE	BOTH RELAYS ALLOWED	
1-34	SMDR PRINT FORMAT	ALL DIGITS	
1-36	INTERCOM MASTER NUMBER	NOT ASSIGNED	
1-37	CO/PBX LINE ON HOOK ORIGINATION/ ABANDONING	NO	

**JOB SPECIFICATION INSTRUCTIONS  
 FOR  
 MEMORY BLOCKS 1-42 ~ 1-44, 1-50 ASSIGNMENT OF SYSTEM MODE FUNCTIONS**

ITEM	DESCRIPTION	ENTRY
MEMORY BLOCK	FUNCTION (AREA)	DEFAULT
1-42	DOOR PHONE CALL AUTOMATIC ANSWER (ALLOW/DENY)	DENY
1-43	EXTERNAL TONE SIGNAL CONTROL	NO
1-44	TANDEM CONFERENCE LINE	21
1-50	AUTOMATIC RELEASE DISCONNECTION SIGNAL DETECTION	150 msec

<p>NEW</p>	<p>SPECIFY WHETHER OR NOT TO ALLOW ANSWERING DOOR PHONE CALLS BY SIMPLY LIFTING THE HANDSET</p>	<p>ALLOW OR DENY</p>		
<table border="1" style="width: 100px;"> <tr> <td style="text-align: center;">DAY</td> <td style="text-align: center;">NIGHT</td> </tr> </table>	DAY	NIGHT	<p>SPECIFY WHETHER OR NOT TO RING THE EXTENSION BELL ON ALL INCOMING CO/PBX CALLS FOR DAY, NIGHT OR BOTH</p>	<p>YES OR NO</p>
DAY	NIGHT			
<p>CONFERENCE</p>	<p>INTERCOM PATH USED FOR TANDEM CONFERENCE</p>	<p>PORT NO. 12-33</p>		
<p>STATION</p>	<p>TIMING OF DETECTING THE DISCONNECT SIGNAL SENT FROM THE OPPOSITE STATION</p>	<p>150/300/400 msec</p>		



**MEMORY BLOCKS 1-42 ~ 1-44, 1-50 ASSIGNMENT OF SYSTEM MODE FUNCTIONS**

MEMORY BLOCK	FUNCTION (AREA)	DEFAULT	NEW
1-42	DOOR PHONE CALL AUTOMATIC ANSWER (ALLOW/DENY)	DENY	
1-43	EXTERNAL TONE SIGNAL CONTROL	NO	DAY NIGHT
1-44	TANDEM CONFERENCE LINE	21	
1-50	AUTOMATIC RELEASE DISCONNECTION SIGNAL DETECTION	150 msec	

**JOB SPECIFICATION INSTRUCTIONS  
 FOR  
 MEMORY BLOCKS 1 - 51, 1 - 53 and 1 - 54 SYSTEM RESTRICTIONS**

ITEM	DESCRIPTION	ENTRY								
<table border="1" style="width: 100%; border-collapse: collapse;"> <tr> <td colspan="2" style="text-align: center;">MEMORY BLOCK 1-51 (DEFAULT: 1 + DIAL)</td> </tr> <tr> <td style="text-align: center;"><input type="checkbox"/></td> <td style="text-align: center;">DIRECT DIAL</td> </tr> <tr> <td style="text-align: center;"><input type="checkbox"/></td> <td style="text-align: center;">1 + DIAL</td> </tr> </table>	MEMORY BLOCK 1-51 (DEFAULT: 1 + DIAL)		<input type="checkbox"/>	DIRECT DIAL	<input type="checkbox"/>	1 + DIAL	<p style="text-align: center;">DIALING METHOD USED FOR TOLL CALLING</p> <p style="text-align: center;">✓ APPROPRIATE TYPE (ONE ONLY)</p>			
MEMORY BLOCK 1-51 (DEFAULT: 1 + DIAL)										
<input type="checkbox"/>	DIRECT DIAL									
<input type="checkbox"/>	1 + DIAL									
<table border="1" style="width: 100%; border-collapse: collapse;"> <tr> <td colspan="2" style="text-align: center;">MEMORY BLOCK 1-53 (DEFAULT : None)</td> </tr> <tr> <td style="text-align: center;"> </td> <td style="text-align: center;">REJECTION CODE 1 (SINGLE DIGIT)</td> </tr> <tr> <td style="text-align: center;"> </td> <td style="text-align: center;">REJECTION CODE 2 (SINGLE DIGIT)</td> </tr> <tr> <td style="text-align: center;"> </td> <td style="text-align: center;">REJECTION CODE 3</td> </tr> </table>	MEMORY BLOCK 1-53 (DEFAULT : None)			REJECTION CODE 1 (SINGLE DIGIT)		REJECTION CODE 2 (SINGLE DIGIT)		REJECTION CODE 3	<p style="text-align: center;">REJECTION OF FIRST DIGIT DIALED</p> <p style="text-align: center;">1 - 9 EACH OF THE FOUR BOXES</p>	
MEMORY BLOCK 1-53 (DEFAULT : None)										
	REJECTION CODE 1 (SINGLE DIGIT)									
	REJECTION CODE 2 (SINGLE DIGIT)									
	REJECTION CODE 3									
<table border="1" style="width: 100%; border-collapse: collapse;"> <tr> <td colspan="2" style="text-align: center;">MEMORY BLOCK 1-54 (DEFAULT : NOT ASSIGNED)</td> </tr> <tr> <td style="text-align: center;">TABLE</td> <td style="text-align: center;">OCC CODE</td> </tr> <tr> <td style="text-align: center;">1</td> <td style="text-align: center;">10-      </td> </tr> <tr> <td style="text-align: center;">2</td> <td style="text-align: center;">10-      </td> </tr> </table>	MEMORY BLOCK 1-54 (DEFAULT : NOT ASSIGNED)		TABLE	OCC CODE	1	10-	2	10-	<p style="text-align: center;">ASSIGNMENT OF EIGHT OTHER COMMON CARRIERS</p> <p style="text-align: center;">3 DIGIT CARRIER CODE</p>	
MEMORY BLOCK 1-54 (DEFAULT : NOT ASSIGNED)										
TABLE	OCC CODE									
1	10-									
2	10-									

**MEMORY BLOCKS 1 - 51, 1 - 53 and 1 - 54 SYSTEM RESTRICTIONS**

MEMORY BLOCK 1-53 = 1 + Dialing (DEFAULT: 1 + DIAL)	MEMORY BLOCK 1-53 = Digit Rejection (DEFAULT : None)	MEMORY BLOCK 1-54 = OCC Override Table (DEFAULT : NOT ASSIGNED)	
		TABLE	OCC CODE
<input type="checkbox"/> DIRECT DIAL	REJECTION CODE 1 (SINGLE DIGIT)	1	10-
<input type="checkbox"/> 1 + DIAL	REJECTION CODE 2 (SINGLE DIGIT)	2	10-
	REJECTION CODE 3 (SINGLE DIGIT)	3	10-
	REJECTION CODE 4 (SINGLE DIGIT)	4	10-
		5	10-
		6	10-
		7	10-
		8	10-

**JOB SPECIFICATION INSTRUCTIONS  
 FOR  
 MEMORY BLOCKS 1 - 52 and 1 - 55 SYSTEM RESTRICTIONS**

ITEM	DESCRIPTION	ENTRY
------	-------------	-------

00 - 80

ENTER THE LINE NUMBER TO DIVIDE THE OVERRIDE TABLE INTO AN ALLOW AND DENY GROUP. AN ENTRY NUMBER DESIGNATES THE LAST ALLOW ENTRY. ALL REMAINING ENTRIES, UP TO 80, WILL BE DENY ENTRIES. ENTER 00 TO SPECIFY ALL ENTRIES AS DENY ENTRIES, OR 80 TO SPECIFY ALL ENTRIES AS ALLOW ENTRIES.

MEMORY BLOCK 1-52 (DEFAULT: 00)	
TABLE SIZE	

MEMORY BLOCK 1-55 (DEFAULT: NOT ASSIGNED)		
ENTRY NO.	AREA	OFFICE
01		
02		
03		
04		
05		

0 - 9, NO CODE (ALL DIGITS)

PERMITS UP TO SIX DIGITS PER ENTRY (3 FOR AREA CODE AND 3 FOR OFFICE CODE).

MEMORY BLOCKS 1 - 52 and 1 - 55 SYSTEM RESTRICTIONS

MEMORY BLOCK 1-52 = Toll Restriction Allow Table Size (DEFAULT: 00)	
TABLE SIZE	

MEMORY BLOCK 1-55 = Toll Restriction Override Table (DEFAULT: NOT ASSIGNED)											
ENTRY NO.	CODE		ENTRY NO.	CODE		ENTRY NO.	CODE		ENTRY NO.	CODE	
	AREA	OFFICE		AREA	OFFICE		AREA	OFFICE		AREA	OFFICE
01			21			41			61		
02			22			42			62		
03			23			43			63		
04			24			44			64		
05			25			45			65		
06			26			46			66		
07			27			47			67		
08			28			48			68		
09			29			49			69		
10			30			50			70		
11			31			51			71		
12			32			52			72		
13			33			53			73		
14			34			54			74		
15			35			55			75		
16			36			56			76		
17			37			57			77		
18			38			58			78		
19			39			59			79		
20			40			60			80		

**JOB SPECIFICATION INSTRUCTIONS  
 FOR  
 MEMORY BLOCK 2 - 01 ASSIGNMENT OF TENANT MODE FUNCTIONS**

**ITEM                      DESCRIPTION                      ENTRY**  
 ALLOWS OR DENIES EACH  
 TENANT CO/PBX ACCESS.

<b>MEMORY BLOCK</b>		2 - 01 Tenant CO/PBX Line Accommodation							
<b>ITEM</b>		TENANT CO/PBX LINE ACCOMMODA							
<b>DEFAULT</b>		CO/PBX LINES 1 TO 8 ASSIGNED TO TENANT 0.							
<b>CO NO.</b>		1	2	3	4	5	6	7	8
<b>TENANT NO.</b>		0							
		1							
		2							
		3							

**MEMORY BLOCK 2 - 01 ASSIGNMENT OF TENANT MODE FUNCTIONS**

MEMORY BLOCK	2 - 01 Tenant CO/PBX Line Accommodation							
ITEM	TENANT CO/PBX LINE ACCOMMOD							
DEFAULT	CO/PBX LINES 1 TO 8 ASSIGNED TO TENANT 0.							
CO NO.	1	2	3	4	5	6	7	8
TENANT NO.	0							
	1							
	2							
	3							

**JOB SPECIFICATION INSTRUCTIONS  
FOR  
MEMORY BLOCKS 3-01 ~ 3-09 and 3-20 ASSIGNMENT OF CO LINE MODE FUNCTIONS**

ITEM	SEIZED SELF CO/PBX NUMBER DISPLAY	CO/PBX LINE STATUS SELECTION						AUTOMATIC RELEASE SELECTION		
		CO/PBX LINE FUNCTION	POLARITY REVERSAL	LINE TYPE		DP/DTMF SELECTION		DENY		
				CO LINE	PBX	DP/ 10 PPS	DTMF			
DEFAULT	NOT ASSIGNED	ORIGINATION & ANSWERING	NO	CO LINE	PBX	NO	DP/ 20 PPS	DTMF	DENY	ALLOW
CO NO. 1		ORIGINATION & ANSWERING	NO	CO LINE	PBX	NO	DP/ 10 PPS	DTMF		
2										
3										
4										

**ITEM DESCRIPTION ENTRY**

- ① TELEPHONE NUMBER TO BE ASSIGNED      0-9, PAUSE OR SPACE
- ② LINE FUNCTION ASSIGNMENT      ✓ APPROPRIATE COLUMN
- ③ LINE POLARITY REVERSAL ASSIGNMENT      ✓ APPROPRIATE COLUMN
- ④ LINE SPECIFICATION ASSIGNMENT      ✓ APPROPRIATE COLUMN
- ⑤ LINE DIAL SIGNAL ASSIGNMENT      ✓ APPROPRIATE COLUMN
- ⑥ AUTOMATIC RELEASE ASSIGNMENT      ✓ APPROPRIATE COLUMN



MEMORY BLOCKS 3-01 ~ 3-09 and 3-20 ASSIGNMENT OF CO LINE MODE FUNCTIONS

ITEM	3-01~08		3-09						3-20	
	SEIZED SELF CO/PBX NUMBER DISPLAY	NOT ASSIGNED	CO/PBX LINE STATUS SELECTION						AUTOMATIC RELEASE SELECTION	
			CO/PBX LINE FUNCTION	POLARITY REVERSAL	LINE TYPE		DP/DTMF SELECTION		DENY	ALLOW
DEFAULT		ORIGINATION & ANSWERING	NO	CO LINE		DTMF				
			NO	YES	CO LINE	PBX	NO	DP/ 10 PPS	DP/ 20 PPS	DTM
1										
2										
3										
4										
5										
6										
7										
8										
CO NO.										

**JOB SPECIFICATION INSTRUCTIONS  
 FOR  
 MEMORY BLOCKS 4-01 ~ 4-03 ASSIGNMENT OF TELEPHONE MODE FUNCTIONS**

ITEM	TELEPHONE STATUS SELECTION I			TELEPHONE STATUS SELECTION II			EXTENSION NUMBER ASSIGNMENT
	TENANT NO.	DSS CALL NO.	EXTENSION GROUP	THREE-MINUTE ALARM (ALLOW/DENY)	OFF-HOOK RINGING TONE	PRIME LINE ASSIGNMENT	
DEFAULT	TENANT 0	DSS 1	GROUP 1	DENY	PORTS 10, 11 ONLY	DENY	PORT NUMBER = EXTENSION NUMBER
	0~3	DSS 1 DSS 2	GROUP 1 GROUP 2 GROUP 3	ALLOW DENY	ALLOW DENY	ALLOW DENY	10~59
10							
11							
12							
13	①	②	③	④	⑤	⑥	⑦

DENY

- |                                |                      |                                      |                      |
|--------------------------------|----------------------|--------------------------------------|----------------------|
| <b>ITEM DESCRIPTION</b>        | <b>ENTRY</b>         | <b>ITEM DESCRIPTION</b>              | <b>ENTRY</b>         |
| ① TENANT NUMBER TO BE ASSIGNED | ✓ 0, 1, 2, OR 3      | ④ THREE MINUTE ALARM TONE ASSIGNMENT | ✓ APPROPRIATE COLUMN |
| ② DSS ASSIGNMENT               | ✓ IF APPROPRIATE     | ⑥ OFF-HOOK RINGING TONE ASSIGNMENT   | ✓ APPROPRIATE COLUMN |
| ③ STATION GROUP ASSIGNMENT     | ✓ APPROPRIATE COLUMN | ⑦ PRIME LINE ASSIGNMENT              | ✓ APPROPRIATE COLUMN |
|                                | N                    | ⑧ STATION NUMBER TO BE ASSIGNED      | EXTENSION (10-59)    |

MEMORY BLOCKS 4-01 ~ 4-03 ASSIGNMENT OF TELEPHONE MODE FUNCTIONS

ITEM	4-01 TELEPHONE STATUS SELECTION I				4-02 TELEPHONE STATUS SELECTION II				EXTENSION NUMBER ASSIGNMENT	
	TENANT NO.	DSS CALL NO.	EXTENSION GROUP			THREE-MINUTE ALARM (ALLOW/DENY)	OFF-HOOK RINGING TONE	PRIME LINE ASSIGNMENT		PORT NUMBER * EXTENSION NUMBER
			DSS 1	GROUP 1	GROUP 2					
DEFAULT	TENANT 0	DSS 1	GROUP 1	GROUP 2	GROUP 3	DENY	PORTS 10, 11 ONLY	DENY	10~59	
	0~3	DSS 1				ALLOW	ALLOW	ALLOW		
		DSS 2				DENY	DENY	DENY		
	10									
	11									
	12									
	13									
	14									
	15									
	16									
	17									
	18									
	19									
	20									
	21									
	22									
	23									
	24									
	25									
	26									
	27									
	28									
	29									
	30									
	31									
	32									
	33									

**JOB SPECIFICATION INSTRUCTIONS  
 FOR  
 MEMORY BLOCKS 4 - 04 and 4 - 06 ASSIGNMENT OF TELEPHONE MODE FUNCTIONS**

4-04

4-06

ITEM	AUTOMATIC CO/PBX LINE SEIZURE						RINGING TONE ASSIGNMENT																	
	CO 1		CO 2		CO 3		CO 4		CO 5		CO 6		CO 7		CO 8		TEL RINGING TONE VARIATION		DOOR PHONE RINGING TONE ASSIGNMENT					
	ALLOW	DENY	ALLOW	DENY	ALLOW	DENY	ALLOW	DENY	ALLOW	DENY	ALLOW	DENY	ALLOW	DENY	ALLOW	DENY	DAY	NIGHT	DOOR PHONE 1 DAY	DOOR PHONE 1 NIGHT	DOOR PHONE 2 DAY	DOOR PHONE 2 NIGHT		
A=ALLOW D=DENY	D	A	A	D	A	D	A	A	D	A	D	A	D	A	D	A	D	A	D	A	D	A	D	A
10																								
11																								
12																								
PORT NUMBER																								

**ITEM DESCRIPTION ENTRY**

- ① AUTOMATIC LINE SEIZURE/PRIME LINE ASSIGNMENT ✓ APPROPRIATE COLUMN
- ② RINGING TONE ASSIGNMENT ✓ APPROPRIATE COLUMN (L)LOW, (M)MEDIUM, (H)HIGH
- ③ DOOR PHONE RINGING TONE ASSIGNMENT ✓ APPROPRIATE COLUMN (MAX. OF 6 STATIONS PER DOOR PHONE CAN BE ASSIGNED TO RING)

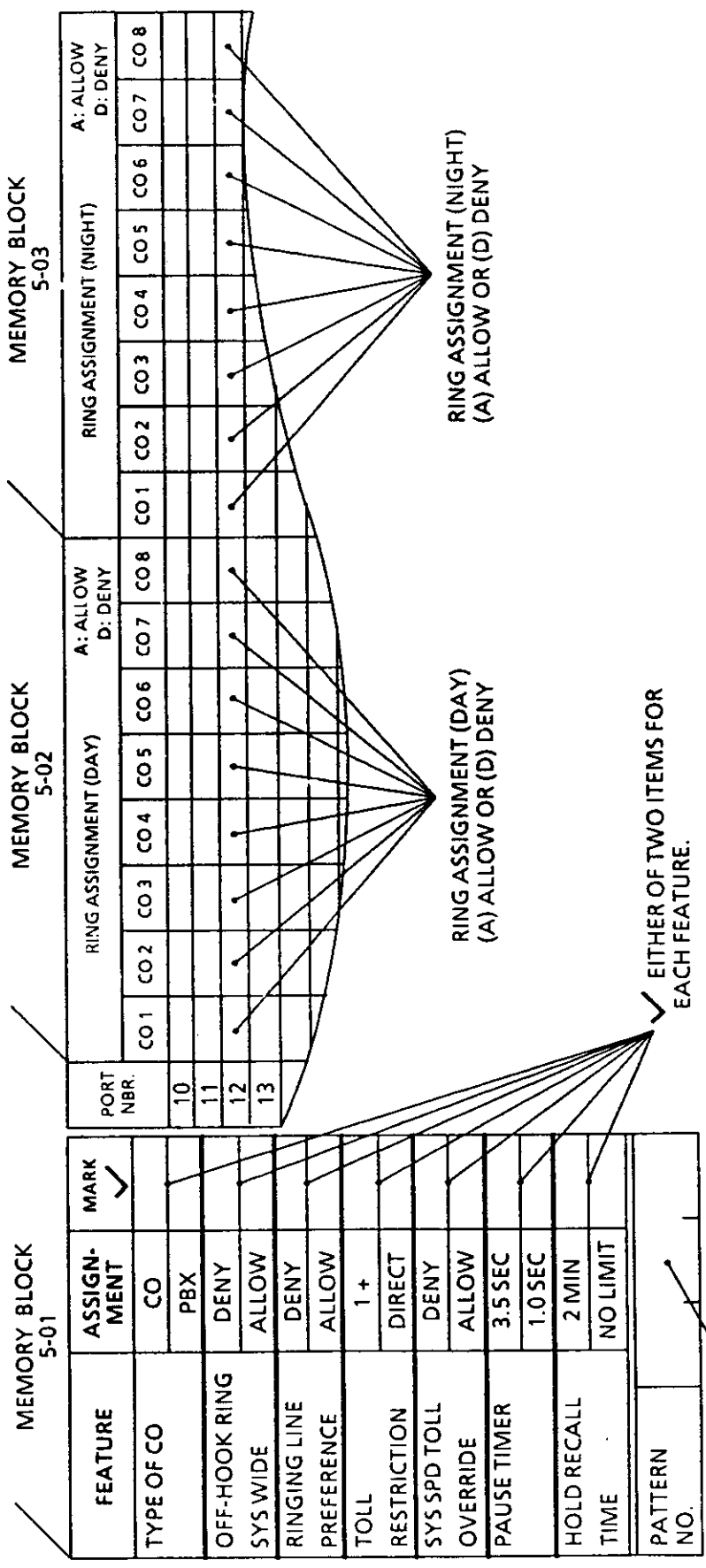
MEMORY BLOCKS 4 - 04 and 4 - 06 ASSIGNMENT OF TELEPHONE MODE FUNCTIONS

4-06

4-04

ITEM	AUTOMATIC CO/PBX LINE SEIZURE/PRIME LINE ASSIGNMENT										RINGING TONE ASSIGNMENT												
	CO 1		CO 2		CO 3		CO 4		CO 5		CO 6		CO 7		CO 8		TEL RINGING TONE VARIATION		DOOR PHONE 1 RINGING TONE ASSIGNMENT		DOOR PHONE 2 RINGING TONE ASSIGNMENT		
	ALLOW	DENY	ALLOW	DENY	ALLOW	DENY	ALLOW	DENY	ALLOW	DENY	ALLOW	DENY	ALLOW	DENY	ALLOW	DENY	ALLOW	DENY	DAY	NIGHT	DAY	NIGHT	
DEFAULT	A	D	A	D	A	D	A	D	A	D	A	D	A	D	A	D	A	D	L (LOW)	PORTS 10, 11 ONLY	PORTS 10, 11 ONLY	PORTS 10, 11 ONLY	PORTS 10, 11 ONLY
A = ALLOW																							
D = DENY																							
10																							
11																							
12																							
13																							
14																							
15																							
16																							
17																							
18																							
19																							
20																							
21																							
22																							
23																							
24																							
25																							
26																							
27																							
28																							
29																							
30																							
31																							
32																							
33																							

**JOB SPECIFICATION INSTRUCTIONS  
 FOR  
 MEMORY BLOCKS 5-01 ~ 5-03 MENU PROGRAMING**



PATTERN NUMBERS SELECTED FROM PATTERN TABLE (SEE SECTION 340 MEMORY BLOCK 5-01) ENTER FROM 000 TO 127

MEMORY BLOCKS 5-01 ~ 5-03 MENU PROGRAMING

MEMORY BLOCK 5-01		MEMORY BLOCK 5-02								MEMORY BLOCK 5-03									
FEATURE	ASSIGNMENT	MARK	RING ASSIGNMENT (DAY)								RING ASSIGNMENT (NIGHT)								
			CO 1	CO 2	CO 3	CO 4	CO 5	CO 6	CO 7	CO 8	CO 1	CO 2	CO 3	CO 4	CO 5	CO 6	CO 7	CO 8	
TYPE OF CO	CO	Y																	
OFF-HOOK RING	PBX																		
SYSTEM WIDE	DENY																		
RINGING LINE	ALLOW																		
PREFERENCE	DENY																		
TOLL	ALLOW																		
RESTRICTION	1 +																		
SYSTEM SPEED	DIRECT																		
TOLL OVERRIDE	DENY																		
PAUSE TIMER	ALLOW																		
	3.5 SEC																		
	1.0 SEC																		
HOLD RECALL TIME	2 MIN																		
	NO LIMIT																		
PATTERN NO.																			

**JOB SPECIFICATION INSTRUCTIONS  
 FOR  
 MEMORY BLOCK 5 - 04 NON/TOLL/OUTGOING RESTRICTION**

<b>ITEM</b>	<b>DESCRIPTION</b>	<b>ENTRY</b>
-------------	--------------------	--------------

RESTRICTION PATTERN FOR EACH STATION AND EACH CO LINE

{ N: NO RESTRICTION  
 O: OUTGOING RESTRICTION  
 T: TOLL RESTRICTION

PORT NO.	NON/TOLL/OUTGOING RESTRICTION							
	CO 1	CO 2	CO 3	CO 4	CO 5	CO 6	CO 7	CO 8
10								
11								
12								
13								

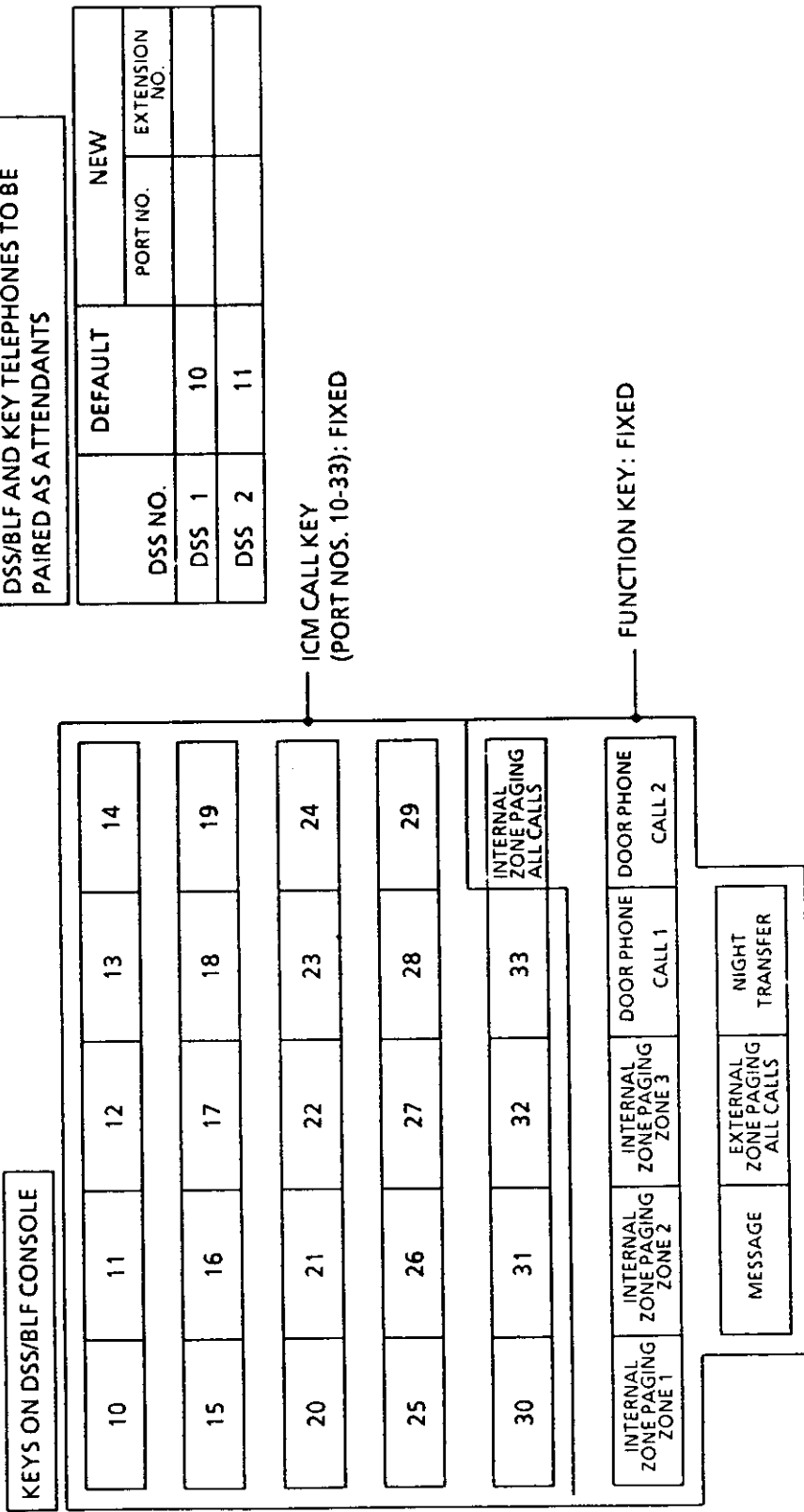


MEMORY BLOCK 5 - 04 NON/TOLL/OUTGOING RESTRICTION

PORT NO.	NON/TOLL/OUTGOING RESTRICTION							
	CO 1	CO 2	CO 3	CO 4	CO 5	CO 6	CO 7	CO 8
10								
11								
12								
13								
14								
15								
16								
17								
18								
19								
20								
21								
22								
23								
24								
25								
26								
27								
28								
29								
30								
31								
32								
33								

### DSS/BLF CONSOLE LAYOUT

1. UP TO TWO DSS/BLF CONSOLES CAN BE USED IN PAIRS WITH KEY TELEPHONES IN A SYSTEM.
2. KEY ASSIGNMENT ON THE DSS/BLF CONSOLE IS AS SHOWN BELOW. ICM CALL KEYS (PORT NUMBERS 10 THROUGH 33) AND FUNCTION KEYS ARE FIXED.
3. KEY TELEPHONE IN PORT NUMBER 10 IS INITIALLY PAIRED WITH DSS 1 AND KEY TELEPHONE IN PORT NUMBER 11 WITH DSS 2 AS ATTENDANT CONSOLES. THESE DEFAULT NUMBERS CAN BE CHANGED AS DESIRED. (REFER TO MEMORY BLOCK 1-17 IN SECTION 340 SYSTEM PROGRAMMING DATA SHEETS.)



**SPEED DIAL ASSIGNMENT LISTING**

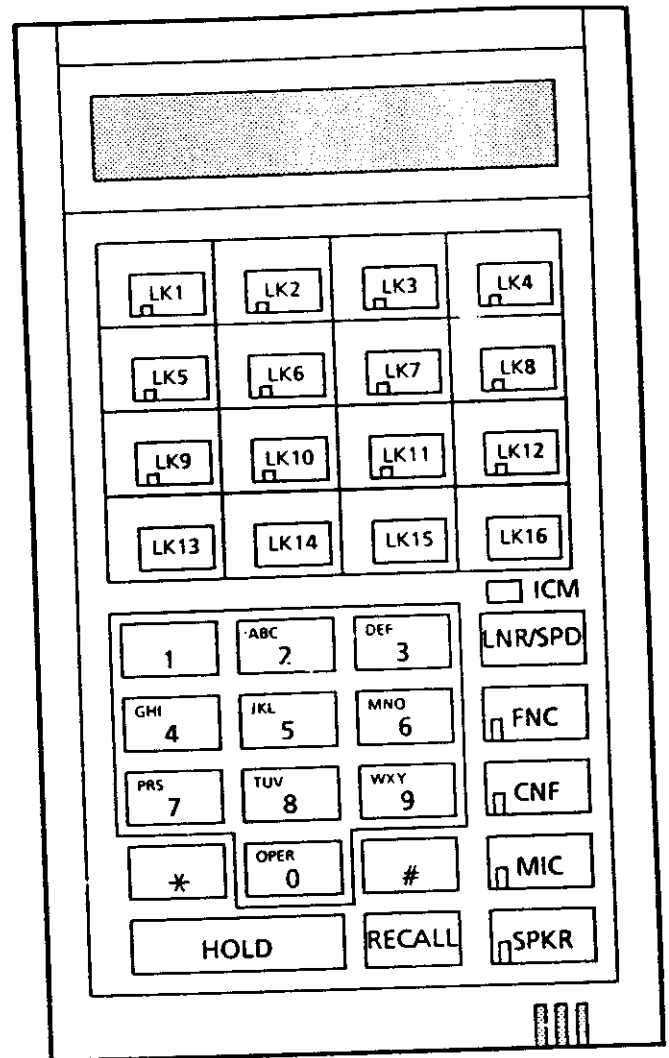
\* UP TO 80 SPEED DIAL NUMBERS FOR COMMON USE BY ALL TENANTS CAN BE REGISTERED.

BUFFER	NUMBER STORED
20	
21	
22	
23	
24	
25	
26	
27	
28	
29	
30	
31	
32	
33	
34	
35	
36	
37	
38	
39	
40	
41	
42	
43	
44	
45	
46	

BUFFER	NUMBER STORED
47	
48	
49	
50	
51	
52	
53	
54	
55	
56	
57	
58	
59	
60	
61	
62	
63	
64	
65	
66	
67	
68	
69	
70	
71	
72	
73	

BUFFER	NUMBER STORED
74	
75	
76	
77	
78	
79	
80	
81	
82	
83	
84	
85	
86	
87	
88	
89	
90	
91	
92	
93	
94	
95	
96	
97	
98	
99	





**KEY FUNCTION (OFF LINE)**

* # keys	— Shift setting position
Dial key	— Inputs function No. and data
MIC	— Data is Entered
SPKR	— ON line
HOLD	— Clear Function, Data
FNC	— Shift to Memory Block 6A & B
CNF	— Shift to Memory Block 6C

If any of the data items are registered while a telephone is in use, the LCD will display

**DATA SEE ON LINE**

without returning to the time display, even though the off-line mode is released, by depressing the SPKR key. When all circuits in the system become idle, the data is updated and the on-line mode is restored.

(

# **CHAPTER 4**

# **STATION OPERATION**





# CHAPTER 4

## STATION OPERATION

	PAGE	PAGE
<b>410 General</b>	400-2	
<b>420 Key Telephone Operation</b>	400-3	<b>430 Attendant Operation</b>
420.1 CO/PBX (Outside) Calls	400-10	430.1 CO/PBX (Outside) Calls
420.2 Extension (Internal) Calls	400-12	430.2 Extension (Internal) Calls
420.3 Handsfree Call	400-14	430.3 Attendant Transfer
420.4 Convenient Features On CO/PBX Calls	400-17	430.4 Internal Zone Paging
420.5 Transfer	400-20	430.5 External Zone Paging
420.6 Conference	400-25	430.6 Message Waiting
420.7 Internal Zone Paging	400-26	430.7 Night Transfer
420.8 External Zone Paging	400-27	430.8 Call Forwarding
420.9 Step Call-Intercom	400-28	430.9 Programming System Speed Dial
420.10 Dial 0 For Attendant	400-29	430.10 Clock/Calendar Setting
420.11 Call Pickup	400-30	430.11 Security Alarm
420.12 Security / Alarm	400-31	
420.13 Callback Request	400-32	<b>440 Feature Access Code List</b>
420.14 Door Phone Calls/Door Lock Release	400-33	
420.15 Tone Override	400-34	
420.16 Call Waiting	400-35	
420.17 Automatic Callback	400-36	
420.18 Do Not Disturb	400-37	
420.19 Call Forward	400-38	
420.20 Programming Station Speed Dial	400-40	
420.21 Programming Feature Access Codes	400-42	
420.22 Nesting Dial	400-44	
420.23 Station Background Music	400-45	
420.24 Ringing Tone Variation Assignment	400-46	
420.25 Ringing Assignment	400-47	
420.26 Off-Hook Ringing Assignment	400-47	
420.27 Self Extension Number Confirmation	400-48	
420.28 Recording Jack (ETZ-16D-1 only)	400-48	
420.29 PC Connection (ETZ-16D-1 only)	400-48	

## 410 GENERAL

The ELECTRA 8/24 Station User's Operation Guide is divided into three sections. Each section is further sub-divided to provide a detailed step-by-step feature operation guide. The Operation Guide provides the LED and LCD status for each feature at each point of operation.

The remaining sections of Chapter 4 are:

- 420 Key Telephone Operation
- 430 Attendant Operation
- 440 Feature Access Code List

Section 420 includes all operations available to Key Telephones.

Section 430 augments section 420; with only Attendant operations included in this section.

Section 440 provides a list of System Feature Access Codes, that can be registered on the Programmable Feature Keys (LKs).

**NOTE:** This chapter describes on hook origination procedures (monitor mode) for outgoing calls. The handset may be lifted at anytime during on hook origination (monitor mode) or conversation. An outgoing call can also be originated by depressing an idle CO/PBX key, after lifting the handset (Off-hook).

## 420 Key Telephone Operation

### 420.1 CO/PBX (Outside) Calls

#### 420.1.1 Originating

##### a. Manual Dialing

- Depress an idle CO/PBX line key.
- Dial desired number.
- Lift handset to converse with called party.

##### b. Dial Access on Intercom Line (MF System only)

- Depress **SPKR** key (or lift handset) to receive dial tone.
- Dial trunk access code (Default 9) and desired number.
- Lift handset to converse with called party.

##### c1. Last CO/PBX Number Redial (MF operation)

- Depress **LNR /SPD** key.
- Dial #.

### SAMPLE LED INDICATIONS

**SPKR** LED lights.

**CO/PBX** green LED winks.

**SPKR** LED goes off.

**SPKR** and **ICM** LED's light.

**ICM** LED goes off.

**CO/PBX** green LED winks.

**SPKR** LED goes off.

**CO/PBX** green LED winks.

**SPKR** LED lights.

L I

S 1 6 7 5 3 7 0 0 0

0 0 - 5 9

1 0 - 5 3

L I

S 1 6 7 5 3 7 0 0 0

0 0 - 5 9

L N R - S P D

L 2 = 5 1 6 7 5 3 7 0 0 0

SAMPLE LED INDICATIONS

— OR —

- Depress FNC key and dial 5.

**NOTE:** If a Feature Access key is programmed for LNR and depressed instead of LNR/SPD, the last number is automatically redialed and displayed.

- Lift handset to converse with called party.

c2. Last CO/PBX Number Redial (KF Operation)

- Depress CO/PBX Line Key.
- Depress LNR/SPD key.

Dial #.

— OR —

- Depress CO/PBX Line Key.
- Depress FNC key and dial 5.
- Lift handset to converse when called party answers

**NOTE:** If a Feature Access key is programmed for LNR and depressed after selecting a CO/PBX line instead of LNR/SPD, the last number is automatically redialed and displayed.

d. Automatic Redial

**NOTE:** By dialing a Feature Access code - when the called outside party is busy, call origination is automatically repeated at a specified interval and number of redials by, programming of the system data.

SAMPLE LCD INDICATIONS

**CO/PBX** green LED winks.

LN=5167537000

**SPKR** LED goes off.

00-59

**CO/PBX** green LED winks.

LI

**SPKR** LED lights.

LNR L SPd

**CO/PBX** green LED winks.

LN=5167537000

**SPKR** LED goes off.

00-59

SAMPLE LED INDICATIONS

To Set

- Upon receiving busy tone from CO/PBX line.
- Depress **SPKR** key and return handset to cradle.
- Depress **FNC** key.
- Depress **LNR/SPD** key.
- Call origination is repeated 5 times automatically.
- Lift handset to respond when outside party answers.

To Cancel

- Depress **SPKR** key.
- OR**
- When all dialing attempts are completed, station returns to idle condition.

**CO/PBX** green LED winks.

00-59

**FNC** LED lights.

LS061531000

**FNC** LED blinks.

11

**CO/PBX** green LED winks.

LS061531000

00-59

**CO/PBX** green LED goes off.

1-25 11-59R

**SPKR** LED goes off.

1-25 11-59R

**CO/PBX** green LED goes off.

1-25 11-59R

**SPKR** LED goes off.

1-25 11-59R

**FNC** LED goes off.

1-25 11-59R

SAMPLE LED INDICATIONS

SAMPLE LCD INDICATIONS

e. Station Speed Dialing (MF Operation)

- Depress LNR/SPD key.
- Dial station speed dial buffer number (00 - 19).
- Lift handset to converse with called party.

**NOTE:** For KF operation, depress CO/PBX line key before depressing the LNR/SPD key.

f. System Speed Dialing (MF Operation)

- Depress LNR/SPD key
- Dial system speed dial buffer number (20 - 99).
- Lift handset to converse with called party.

**NOTE:** 1. If the programmed line key, when the speed dial buffer number is programmed, is depressed, the desired number is automatically dialed.

2. For KF operation, depress CO/PBX line key before depressing the LNR/SPD key.

**CO/PBX** green LED winks.

**SPKR** LED lights.

**SPKR** LED goes off.

**CO/PBX** green LED winks.

**SPKR** LED lights.

**SPKR** LED goes off.

LNR SPD

00-19

00-99

LNR SPD

20-99

00-99

SAMPLE LED INDICATIONS

g. Prime Line (Programmable)

- Lift handset to receive dial tone.
- Use any of the dialing methods described:
  - Dial pad
  - System Speed Dial
  - Station Speed Dial

h. Consecutive Speed Dial (MF Operation)

Originating

- Depress LNR/SPD key
- Dial desired Speed Dial buffer number.
- Depress LNR/SPD key.
- Dial desired Speed Dial buffer number  
(Can be continued if needed)
- Lift handset to converse with called party.

NOTE: 1. Use any combination of manual, Station Speed and System Speed Dialing.  
2. For KF operation, depress CO/PBX line key before depressing the LNR/SPD key.

SAMPLE LCD INDICATIONS

L1 [ ] [ ] [ ] [ ] [ ] [ ] [ ] [ ] [ ] [ ]  
S:167537000

LNR [ ] [ ] [ ] [ ] SPD [ ] [ ]  
01=358564 [ ] [ ] [ ] [ ] [ ] [ ]  
LNR [ ] [ ] [ ] [ ] SPD [ ] [ ]  
02=789032 [ ] [ ] [ ] [ ] [ ] [ ]  
[ ] [ ] [ ] [ ] [ ] [ ] [ ] [ ] [ ] [ ] [ ] [ ] [ ] [ ] [ ]

**CO/PBX** green LED winks.

**CO/PBX** green LED winks.  
**SPKR** LED lights.

**SPKR** LED goes off.

SAMPLE LED INDICATIONS

j. Specific CO/PBX Line Seizure

- Depress **SPKR** key.
- Dial 63.
- Dial the specific CO/PBX line number (1 - 8).
- See 420.1 CO/PBX (outside) Calls to continue calling operation.

**ICM** and **SPKR** LED lights.

**ICM** LED goes off.

**CO/PBX** green LED winks.

1 0 - - C - - 3 - - - -

1 0 - - C 6 3 3 - - - -

1 1 - - - - - - - - - -

420.1.2 Answering

a. Manually Selecting Line

- Depress CO/PBX line key associated with flashing LED.
  - Use handset to talk.
- b. Ringing Line Preference
- Lift handset to respond.

**CO/PBX** red LED flashes.

**CO/PBX** green LED winks.

**SPKR** LED lights.

**SPKR** LED goes off.

**CO/PBX** green LED winks.

1 1 - - - - - - - - - -

0 0 - 5 9 - - - - - - - -

0 0 - 5 9 - - - - - - - -

**NOTE:** System data must be programmed for incoming calls to be picked up on Ringing Line Preference.





SAMPLE LED INDICATIONS

SAMPLE LED INDICATIONS

420.2 Extension (Internal) Calls

420.2.1 Originating

- a. Manual Dialing
  - Depress **SPKR** key, ICM dial tone is heard.
  - Dial extension number.
  - Lift handset to converse with called extension.

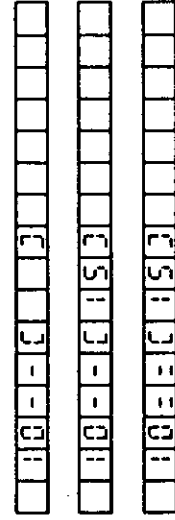
**NOTE:** When a system is programmed for Voice, a caller can Voice Announce or dial 1 to change to tone signaling or vice versa.

- b. Using Feature Access Key
  - Depress **Feature Access** key.
  - Lift handset to converse with called extension.

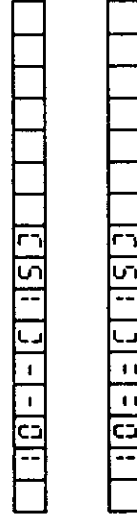
**NOTE:** When **Feature Access** Keys are programmed for internal extension (DSS keys), depression of the **Feature Access** Key allows the user to call a desired extension, instead of manual dialing.

- c. Chain Calling
  - Depress **DSS (1)** key.
  - Depress **DSS (2)** key.

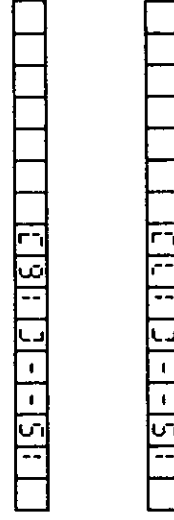
**NOTE:** A **DSS** key is a **Feature Access** Key which has been programmed with an extension number.



**SPKR** and **ICM** LED's light.  
**SPKR** LED goes off.



**SPKR**, **ICM** and **PFA** LED's light.  
**SPKR** LED goes off.



**DSS (1)** LED lights.  
**ICM** and **SPKR** LED's light.  
**DSS (2)** LED lights.  
**DSS (1)** LED goes out.

SAMPLE LED INDICATIONS

420.2.2 Answering

- a. With handset
  - Lift the handset.
- b. With Handsfree
  - Speak to the microphone to answer.

**NOTE:** You can answer an intercom call without lifting the handset if the microphone is on. Depress MIC key(LED lights) to enable the microphone.

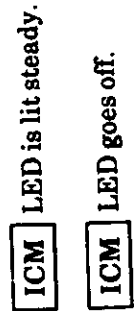
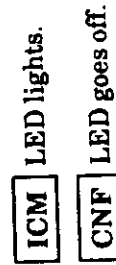
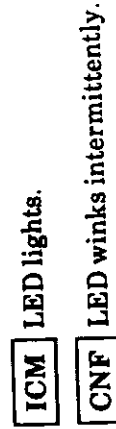
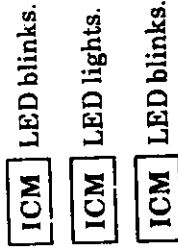
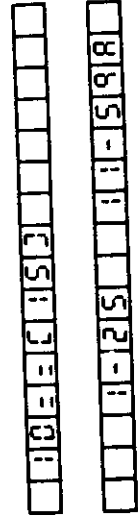
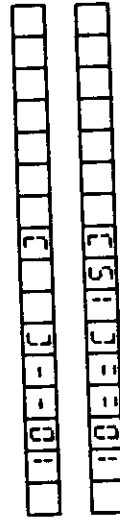
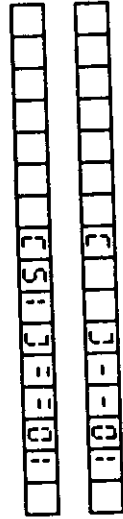
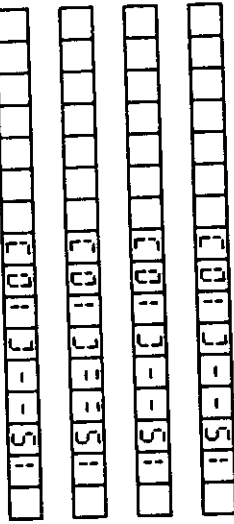
420.2.3 Placing a Call On Hold

- With an intercom call in progress.
  - Depress **HOLD** key for Exclusive Hold.
- To answer a call on hold.
  - Lift handset.
  - Depress **CNF** key.

**NOTE:** To place an ICM call on hold, the calling party must be in an off-hook condition, not in the handsfree answer back mode.

420.2.4 Abandoning a Call

- Restore handset.



SAMPLE LED INDICATIONS

**420.3 Handsfree Call**

Handsfree call origination / answer back is one of the optional features of the Electra 8/24 that allows you to originate or answer calls without lifting the handset.

An ETZ-16D-1 equipped with HFU-Z Unit provides full both way Handsfree operation.

**420.3.1 Originating**

- Depress CO/PBX line key or Feature Access Key.
- Dial desired number.
- Converse with party when answered.

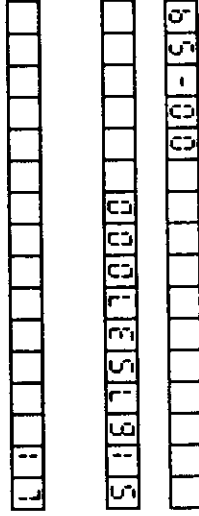
**NOTE:** Make sure that MIC LED is lit.

Any methods described in Section 420.1 and 420.2 can be used for full both way Handsfree operation. When a call is in progress using Handsfree operation, the Key Telephone can not receive Internal Ring Tone, CO/PBX Ring Tone, or Recall Tone.

SAMPLE LCD INDICATIONS

**CO/PBX** green LED winks and

**SPKR** LED lights.



SAMPLE LED INDICATIONS

SAMPLE LCD INDICATIONS

**420.3.2 Answering**

- Depress the line key receiving an incoming call.

**CO/PBX** green LED winks.  
**SPKR** LED lights.



**NOTE:** Make sure that MIC LED is lit.

**420.3.3 Placing a Call On Hold**

See Section 420.1, item 3. and 420.2, item 3. of this manual.

**420.3.4 Abandoning a Call**

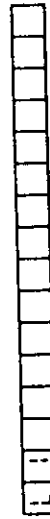
- Depress SKPR key
- Depress CO/PBX key (if system data is programmed for this feature).

**CO/PBX** and **SPKR** LED's go out.



— OR —

- Depress **RECALL** key at the end of the call.
- The call is released and new dial tone is heard.



SAMPLE LED INDICATIONS

SAMPLE LCD INDICATIONS

420.4 Convenient Features On CO/PBX Calls

420.4.1 Privacy Release on CO/PBX Line

If station A releases the Privacy of a call, on a CO /PBX line, station B in the same tenant as A can participate in that call to establish a Conference call.

Stations releasing Privacy (station A) With a call in progress.

- Depress **HOLD** key.
- Notify B that a Conference Call is available.
- Depress held **CO/PBX** line key.
- Depress **CNF** key.
- B depresses associated busy line key to establish a Conference call.

The station that participates in the call (station B)

- Depress **CO/PBX** line key on which A's call is in progress.
- Participate in A's call to establish a Conference.
- Lift handset.

**CO/PBX** LED winks.

00-59

**CO/PBX** LED lights steady.

**CNF** LED slow blinks.

**CNF** LED lights.

153 00-59

**CNF** LED blinking slowly.

**CO/PBX** green LED winks.

**CNF** LED lights.

163 00-59

**SPKR** LED goes off.

SAMPLE LED INDICATIONS

**420.4.2 Privacy Override on CO/PBX Line**

If assigned in system data, a station can Override another station's CO/PBX call.

- Lift handset.
- Depress FNC key.
- Depress CNF key.
- Depress the CO/PBX line key you want to Override.

ICM LED lights.

FNC LED lights.

FNC LED blinks.

FNC LED goes out.

CNF LED lights.

CO/PBX green LED winks.

**NOTE:** 1.This feature is available only to the programmed telephone.  
 2.A Private line cannot be Overridden.  
 3.Privacy Override by extension number is valid only within the same Tenant Group.

**420.4.3 Switching DP to DTMF**

This feature used only on rotary type (DP) lines.

When transmitting to a bank computer or in similar situations, you can switch DP to DTMF signals.

When you hang up, DTMF is automatically switched back to DP.

- After originating a CO/PBX call.
- Dial \* and #.

SAMPLE LCD INDICATIONS

10-10

8-7L50

100

00-59

SAMPLE LED INDICATIONS

SAMPLE LCD INDICATIONS

420.4.4 Receiving Volume Control

Handset receive volume can be adjusted as follows:

With a call (outside / intercom) in progress.

- Depress FNC key.

- Dial 2.

NOTE: When enabled, this feature increases receive volume in the handset by 5dB. This feature cancels when the station user returns the Key Telephone to the on hook condition. In system data, registration cancellation can be assigned not to occur when the Key Telephone is returned to the idle condition. The same procedure is used to set and cancel the feature.

**FNC** LED lights.



-- OR --

**FNC** LED goes off.





SAMPLE LED INDICATIONS

SAMPLE LED INDICATIONS

420.5 Transfer

420.5.1 Call Transfer

With call in progress

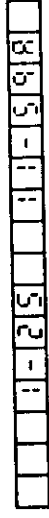
- Depress **HOLD** key; receive Intercom dial tone.
- Dial extension number.
- After called party answers, depress **RECALL** key and restore handset.



**ICM** LED lights.



**CO/PBX** red LED lights.



420.5.2 Ring Transfer

With a call in progress

- Depress **HOLD** key.
- Dial extension number.
- Depress **RECALL** key before answer.
- Restore handset.

**CO/PBX** green LED winks.



**CO/PBX** green LED flashes.



**ICM** LED lights.



**CO/PBX** red LED blinks.



**ICM** LED goes out.



**NOTE:** Unanswered Transferred calls will Recall to the station user who initiated the Transfer after the Recall time interval has elapsed. A recall tone is provided.  
 A Ring Transferred station can answer an incoming outside call by simply lifting the handset.

SAMPLE LED INDICATIONS

SAMPLE LCD INDICATIONS

420.5.3 Group Transfer

To Transfer

With a call in progress

- Depress **HOLD** key
- Dial access code (    ).
- (70) - Internal All Call
- (71) - Internal Zone 1
- (72) - Internal Zone 2
- (73) - Internal Zone 3
- (75) - External All Zone
- (76) - External Zone 1
- (77) - External Zone 2
- Depress **RECALL** key after called party answers.

To Answer

With a page in progress

- Depress **SPKR** key
- Dial access code 74.
- Lift handset to converse with originator.
- Converse with outside party after originator depress **RECALL** key.

**CO/PBX** green LED winks.

**CO/PBX** green LED flashes.

**ICM** LED lights.

**CO/PBX** red LED lights.

**CO/PBX** red LED blinking.

**ICM** and **SPKR** LED's light.

**SPKR** LED goes off.

**CO/PBX** green LED winks.

**ICM** LED goes off.

00-59

15-3

15-303-1P RLL

15-3

10t PRSE

18-3

18-3:153

18-3:153 4rf

00-59

SAMPLE LCD INDICATIONS

SAMPLE LED INDICATIONS

420.5.4 Call Park

To Transfer

With a call in progress

- Depress **HOLD** key.
- Depress **RECALL** key.
- Restore handset.
- Inform the Transferred party of the Transfer.

To Answer

- Depress **SPKR** key.
- Dial 62 to converse with outside party.

**NOTE:** Call Park is available within the same tenant only. When the call placed on Call Park is not answered within the specified time, Recall tone is heard from the speaker of the originating station.

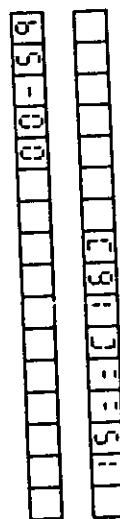
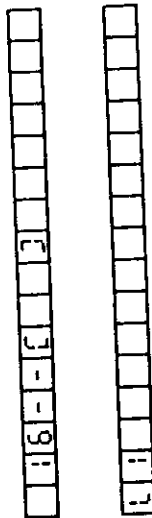
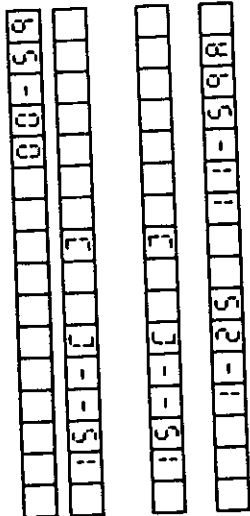
420.5.5 Automatic Hold

To Transfer

With a call in progress

- Depress **DSS** key.

**NOTE:** 1. DSS key is a Feature Access Key with a programmed extension number.  
2. Depressing DSS key automatically holds outside call.



SAMPLE LED INDICATIONS

SAMPLE LED INDICATIONS

**420.6 Conference**

Possible Conferences are as follows:

- 3 stations - No CO/PBX lines
- 2 stations - 1 CO/PBX line
- 1 station - 2 CO/PBX lines.

**NOTE:** 1. When all Conference circuits are busy, CNF LED will light on all Key Telephones. No additional Conferences can be made at this time.  
2. Conference calls cannot be transferred.

**420.6.1 Three Party Conference**

1 CO/PBX line and 2 internal stations

a. With an outside call in progress.

- With first call in progress, depress **HOLD** key to receive intercom dial tone.
- Originate second call and wait for called party to answer.
- Depress **CNF** key and establish a 3 party conference.

b. With an intercom call in progress.

- Depress **Hold** key.
- Depress idle line key and receive dial tone.

**CO/PBX** green LED winks.

**CO/PBX** green LED flashes.

**ICM** LED lights.

**CNF** LED lights.

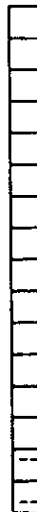
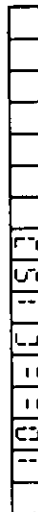
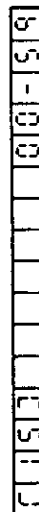
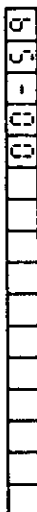
**CO/PBX** green LED winks.

**ICM** LED goes off.

**ICM** LED lights.

**CNF** LED flashes.

**CO/PBX** LED winks.



SAMPLE LED INDICATIONS

- Originate second call and wait for called party to answer.

- Depress CNF key.

2 CO/PBX lines and 1 station.

- With first call in progress, depress HOLD key.

- Depress another line key and originate second call, then wait for called party to answer.

- Depress CNF key and establish a 3 party Conference.

3 Internal stations and no CO/PBX lines.

- With first call in progress, depress HOLD key to receive intercom dial tone.

- Originate another call and wait for called party to answer.

- Depress CNF key and establish a 3 party conference.

SAMPLE LCD INDICATIONS

S	1	6	7	5	3	7	0	0	0	0				
										0	0	-	5	9

C	1	5	3											
										0	0	-	5	9

										0	0	-	5	9

										3				

L	1													
---	---	--	--	--	--	--	--	--	--	--	--	--	--	--

S	1	6	7	5	3	7	0	0	0					
---	---	---	---	---	---	---	---	---	---	--	--	--	--	--

										L	2		0	0	-	5	9

										C	1	1	3				

										C	1	3					

										C	1	5	3				

										C	1	5	3				

**CNF** LED lights.

**CO/PBX** green LED winks.

**CO/PBX** green LED flashes.

**ICM** LED lights.

**CO/PBX** green LED winks.

**ICM** LED goes off.

Both **CO/PBX** green LEDs wink.

**CNF** LED lights.

**ICM** LED is lit steady.

**CNF** LED blinks intermittently.

**CNF** LED lights.

SAMPLE LED INDICATIONS

**420.6.2 Placing a Conference Call on Hold**

Conference with two outside parties.

- With conference call in progress.
- Depress **HOLD** key and hang up.

LEDs associated with the line keys involved show I-Hold (Non Exclusive hold) indication.

**NOTE:** When a conference call using multiple line keys is placed on hold, it splits into individually Held lines.

Conference with 3 internal parties.

- With conference call in progress.
  - Depress **HOLD** key and hang up. Remaining two parties can converse.
- To reenter the Conference.
- Lift handset and depress **CNF** key.

**420.6.3 Abandoning a Conference Call**

a. Exiting from a Conference (more than one internal station)

- With conference call in progress.
- Restore handset.

SAMPLE LCD INDICATIONS

Two **CO/PBX** green LED's wink.

**CNF** LED is lit steady.

**CNF** LED goes off.

**ICM** LED lights.

11 12 00-59

1-25 11-59R

**ICM** and **CNF** LED's light.

**CNF** LED flashes.

**CNF** LED lights.

1113 1153 10F

10-1 3

1113 1153 10F

**ICM** LED is lit steady.

**CNF** LED is lit steady.

**ICM** and **CNF** LEDs go out.

1113 1153 10F

1-25 11-59R

SAMPLE LED INDICATIONS

SAMPLE LED INDICATIONS

Other internal stations stay in the Conference.

b. Abandoning (with a CO/PBX call)

- With conference call in progress.
- Restore handset.

**420.6.4 Tandem Conference**

To Establish

With a three party Conference, including two CO/PBX parties, in progress.

- Depress CNF key.
- Hang up.
- A warning tone is provided after three minutes, and is repeated every three minutes.

To Reenter

With a Tandem Conference in progress.

- Lift handset.
- Depress CNF key to reenter the conference.

CNF and CO/PBX LEDs are lit steady.

CNF CO/PBX LEDs are lit steady.

CNF LED goes out.

CNF LED goes out.

Two CO/PBX green LED's winking.

Two CO/PBX green LED's winking.

CNF LED is lit.

CNF LED is lit.

ICM LED lights.

ICM LED lights.

CNF LED slow blinks.

CNF LED slow blinks.

Two CO/PBX red LED's light.

Two CO/PBX red LED's light.

ICM LED goes off.

ICM LED goes off.

CNF LED flutters.

CNF LED flutters.

Two CO/PBX red LED's light.

Two CO/PBX red LED's light.

CNF LED slow blinking.

CNF LED slow blinking.

ICM LED lights.

ICM LED lights.

CNF LED lights.

CNF LED lights.

CO/PBX green LEDs wink.

CO/PBX green LEDs wink.

ICM LED goes off.

ICM LED goes off.

SAMPLE LED INDICATIONS

SAMPLE LCD INDICATIONS

Abandoning

After reentering the Conference.

- Restore the handset.

Two **CO/PBX** green LED's winking.  
**CNF** LED is lit.

**CO/PBX** and **CNF** LEDs go out.

			1	-	2	5			:	1	-	5	9	A
--	--	--	---	---	---	---	--	--	---	---	---	---	---	---



SAMPLE LED INDICATIONS

SAMPLE LCD INDICATIONS

420.7 Internal Zone Paging

To Originate

- Depress **SPKR** key.
- Dial access code ( ).
- (70) - (All Call)
- (71) - (Zone 1)
- (72) - (Zone 2)
- (73) - (Zone 3)

— OR —

Depress the line key programmed for one of these access codes.

- Use handset to page.

To Answer (Meet-me)

**NOTE:** To use Meet-Me answer feature, a station must be in the same zone being paged.

- Depress **SPKR** key.
- Dial access code 74.

— OR —

Depress the line key programmed for this access code.

- Lift handset to converse with paging party.

SPKR and ICM LED's light.

10-10-11

SPKR and ICM LED's light.

10-10-10 P ALL

10-10-10 P

SPKR and ICM LED's light.

SPKR LED goes off.

ICM and SPKR LED's light.

10-10-10 P A S E

10-10-10 P

10-10-10 P

SPKR and ICM LED's light.

SPKR LED goes off.

10-10-10 P

SAMPLE LED INDICATIONS

SAMPLE LCD INDICATIONS

420.8 External Zone Paging

To Originate

- Depress **SPKR** key.
- Dial access code.

Dialed access code is ( ).

- (76) - (Zone 1)
- (77) - (Zone 2)
- (75) - (All Zones)

— OR —

Depress the line key programmed for one of these access codes.

- Use handset to page.

To Answer (Meet-Me)

- Depress **SPKR** key.
- Dial access code 74.

— OR —

Depress Feature Access Key programmed for access code 74.

- Lift handset to converse with paging party.

**ICM** and **SPKR** LED's light.

10-000000

**ICM** and **SPKR** LED's light.

10-0060EP  
10-0050EP  
ALL

**SPKR** LED goes off.

**ICM** and **SPKR** LED's light.

15-000000  
15000000

**ICM** and **SPKR** LED's light.

**SPKR** LED goes off.

15000000

SAMPLE LED INDICATIONS

SAMPLE LED INDICATIONS

**420.9 Step Call-Intercom**

If the dialed extension is busy, the next idle station within the same tens group will be called. It can be a higher or lower number depending on status of stations within the group.

When the called party's extension is busy and call waiting tone is heard.

- Dial 1.

**NOTE:** If the called STA is the highest number in the extension group, dialing 1 will step the call to the lowest STA.

1	0	-	-	[	1	5	]												
---	---	---	---	---	---	---	---	--	--	--	--	--	--	--	--	--	--	--	--

1	0	-	-	[	1	6	]												
---	---	---	---	---	---	---	---	--	--	--	--	--	--	--	--	--	--	--	--

SAMPLE LED INDICATIONS

SAMPLE LCD INDICATIONS

**420.10 Dial 0 For Attendant**

- Depress SPKR key.
- Dial 0 to call the associated Attendant.
- Lift handset to converse with the Attendant.

**NOTE:** If the associated Attendant is call forwarded to another station, calls to the Attendant will be automatically forwarded to the target station.

**ICM** and **SPKR** LED's light.

15 - [ ] [ ] [ ] [ ] [ ] [ ] [ ] [ ] [ ] [ ]

**SPKR** LED goes off.

15 E [ ] [ ] [ ] [ ] [ ] [ ] [ ] [ ] [ ] [ ]

SAMPLE LED INDICATIONS

SAMPLE LCD INDICATIONS

420.11 Call Pickup

420.11.1 Outside Calls

With incoming CO/PBX Calls

- Depress **SPKR** key
- Dial access code ( ).

— OR —

Depress **Feature Access Key** programmed for this access code.

- Lift handset to converse.

Call Pickup access codes are as follows;

- (60) - For other tenant.
- (66) - For same tenant.

420.11.2 Extension Calls

With incoming Internal Call

- Depress **SPKR** key.
- Dial access code 61.

— OR —

Depress **Feature Access key** programmed for this access code.

- Lift handset to converse.

CO/PBX red LED blinks.  
 ICM and SPKR LED's light.  
 CO/PBX green LED winks.  
 ICM LED goes off.

1-25 11-598

15-6 2

1

SPKR LED goes off.  
 00-59

1-25 11-598

15-6 2

15-6 203

SPKR LED goes off.

SAMPLE LED INDICATIONS

SAMPLE LCD INDICATIONS

**420.12 Security /Alarm**

Two alarm circuits are provided in the system as an option.

When the alarm circuit is activated, this option provides an audible alarm through all idle Key Telephone speakers.

And the alphanumeric display on all Key Telephones with display indicates which alarm circuit has been activated.

Only the Attendant Key Telephone can cancel the alarm signal. See Attendant operation for procedure to cancel alarm.

SAMPLE LED INDICATIONS

SAMPLE LED INDICATIONS

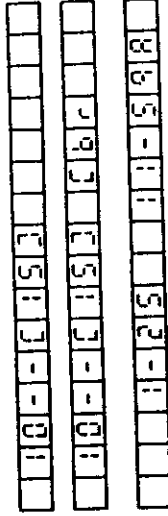
420.13 Callback Request

To Set

Upon no answer when placing an extension call.

- Dial access code#.
- Hang up.

**ICM** LED is lit steady.



**ICM** LED goes off.

**NOTE:** A maximum of 3 Callback Requests can be received by a Key Telephone.

To Cancel

From originating Key Telephone

- Recall the party that Callback Request was sent to.

To Call Back

Key Telephone with an LCD.

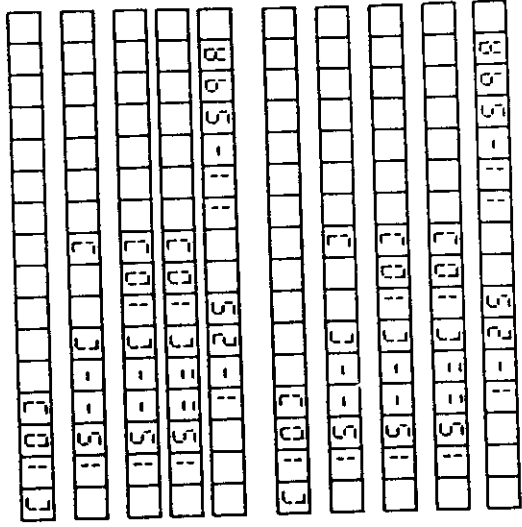
- Depress **SPKR** key.
- Dial extension to be called back.
- Lift handset to converse when party answers.
- Restore handset.

Key Telephone with or without LCD.

- Depress **SPKR** key.
- Dial # on the dial pad.
- Lift handset to converse when party answers.
- Restore handset.

**NOTE:** When one or more Callback Requests are displayed, the parties are called back in order of Callback Requests.

<b>FNC</b>	LED flashes.	<b>FNC</b>	LED goes off.
<b>ICM</b>	and <b>SPKR</b>	<b>ICM</b>	LED's light.
<b>FNC</b>	LED goes off.	<b>FNC</b>	LED goes off.
<b>ICM</b>	LED goes off.	<b>ICM</b>	LED goes off.
<b>FNC</b>	LED flashes.	<b>FNC</b>	LED's light.
<b>ICM</b>	and <b>SPKR</b>	<b>ICM</b>	LED goes off.
<b>FNC</b>	LED goes off.	<b>FNC</b>	LED goes off.
<b>ICM</b>	LED goes off.	<b>ICM</b>	LED goes off.







SAMPLE LED INDICATIONS

SAMPLE LCD INDICATIONS

420.15 Tone Override

To Originate

Upon receiving call waiting tone when placing an extension call.

- Dial access code \*, and receive Override Tone.
- Talk to party when answered.

To Answer

a. With an intercom call in progress.

Upon receiving Override Tone

- Depress **HOLD** key.

b. With an outside call in progress

Upon receiving Override Tone.

- Depress **HOLD** key.

**ICM** LED is lit steady.

10-0153

**ICM** LED is lit steady.

15-0113 E-D

**CNF** LED flashes.

15-0103

**CO/PBX** green LED winks.

15-0123 E-D

**ICM** LED blinks.

15-0103

**CO/PBX** red LED flashes.

15-0103

**ICM** LED lights.

SAMPLE LED INDICATIONS

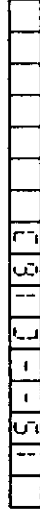
420.16 Call Waiting

A station calling a busy station receives Call Waiting tone. The calling station can remain off-hook (or monitor mode) and, when the called station becomes idle, the intercom call will automatically be processed.

- Call Waiting tone is heard when the called party is busy.
- Remain off-hook.
- When the calling party becomes idle, a warning tone is received by both parties.
- After the warning tone and called party answers, converse.

**NOTE:** The ICM LED on the called station continuously flashes to indicate that a Call is Waiting.

**ICM** LED lights.



SAMPLE LCD INDICATIONS

SAMPLE LED INDICATIONS

SAMPLE LCD INDICATIONS

420.17 Automatic Callback

To Set

Upon receiving Call Waiting tone when placing an extension call.

- Dial access code 0.
- Receive confirmation tone and hang up.
- A Callback tone is provided to the originating station when the called station becomes idle.
- Lift handset.
- Use handset to talk when answered.

**NOTE:** Automatic Callback will be canceled if the Callback is not answered within 30 seconds.

To Cancel

When set in system programming Automatic Callback will time out if unanswered within a predetermined time.

ICM LED is lit steady.

ICM LED goes off.

ICM LED blinks.

ICM LED lights.

10-0-0153

10-0-0153 RA 06

1-25 11-59A

10-0-0153

10-0-0153

SAMPLE LED INDICATIONS

SAMPLE LCD INDICATIONS

420.18 Do Not Disturb

To Set

- Depress FNC key.
- Dial access code 65.
- Depress FNC key.

- FNC** LED lights.
- FNC** LED blinks.
- FNC** LED winks.

11-25 11-59A

d n d S E E

To Cancel

- Depress FNC key.
- Dial access code 65.
- Depress FNC key.

- FNC** LED lights.
- FNC** LED blinks.
- FNC** LED goes off.

11-25 11-59A

d n d E L E R

SAMPLE LED INDICATIONS

SAMPLE LCD INDICATIONS

**420.19 Call Forward**

To Set

- Depress FNC key, dial access code 60, or depress Feature Access Key programmed for this access code.
- Dial extension number where incoming calls to your extension are forwarded to.
- Depress FNC key.

**NOTE:** Access code followed by extension number can be programmed on a Feature Access Key.

To Cancel

- Depress FNC key, dial access code 69, or depress Feature Access Key programmed for this access code.
- Depress FNC key.

**FNC** LED lights.

**FNC** LED blinks.

**FNC** LED slow blinks.

**FNC** LED slow blinks.

**FNC** LED lights.

**FNC** LED blinks.

**FNC** LED goes off.

```

  | | | | | 1 | - | 2 | 5 | | | | 1 | 1 | - | 5 | 9 | 8 | |
  | | | | | C | F | | | | 1 | 0 | - | C | | | | 3 | |
  | | | | | C | F | | | | 1 | 0 | - | C | 1 | 5 | 3 |
  | | | | | 1 | - | 2 | 5 | | | | 1 | 1 | - | 5 | 9 | 8 |
  
```

```

  | | | | | 1 | - | 2 | 5 | | | | 1 | 1 | - | 5 | 9 | 8 |
  
```

```

  | | | | | C | F | | | | C | L | E | A | R | | | |
  | | | | | 1 | - | 2 | 5 | | | | 1 | 1 | - | 5 | 9 | 8 |
  
```

SAMPLE LED INDICATIONS

SAMPLE LCD INDICATIONS

420.20 Programming Station Speed Dial

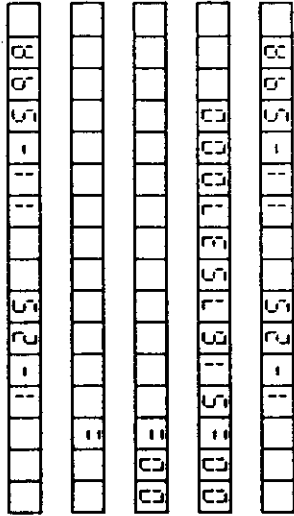
NOTE: The last dialed number can be entered as a Station Speed Dial number.

To Program

a. Speed Dialing

- Depress FNC key.
- Depress LNR/SPD key.
- Dial Speed Dial buffer number (00 - 19).
- Dial telephone number to be stored.
- Depress FNC key.

- FNC** LED lights.
- FNC** LED slow blinks.
- FNC** LED blinks.
- FNC** LED goes off.



- b. To program last dialed number as station speed dial number, depress SPKR key instead of dialing telephone number.

NOTE: 1. When System Speed Dial numbers are to be entered into a Station Speed Dial buffer, depress HOLD and enter the System Speed Dial buffer number (20 - 99) into the Station Speed Dial buffer.

2. Pauses can be inserted into Speed Dial number by depressing the LNR/SPD key. Each pause entered counts as a digit.

3. Hook flash can be entered as the first digit by depressing the RECALL key.



SAMPLE LED INDICATIONS

420.21 Programming Feature Access Codes

See section 440, Feature Access Code List.

To Program

- a. DSS/Speed Dialing
  - Depress FNC key.
  - Depress LNR/SPD key.
  - Depress desired Feature Access key.
  - Dial 0 or 1.  
(0 : CO/PBX call, 1 : Internal call)
  - Depress Speed Dial buffer number (00 - 99) or extension number (10 - 59).
  - Depress FNC key.

FNC	LED lights.	1-25	11-59R
FNC	LED flashes.		
		05E	
		05E0E	
		05E0E78	
FNC	LED goes off.	1-25	11-59R

NOTE: 1. Line key without accommodating CO/PBX line can be programmed as a Feature Access key.  
 2. Paging, Call Pickup, and Door Phone Call can also be programmed as internal calls.

- b. Storing a Feature Access Code
  - Depress FNC key.
  - Depress LNR/SPD key.
  - Depress desired Feature Access key.
  - Dial # and desired feature access codes.
  - Depress FNC key.

FNC	LED lights.	1-25	11-59R
FNC	LED flashes.		
		05E	
		05E0E2	
FNC	LED goes off.	1-25	11-59R



SAMPLE LED INDICATIONS

To Verify

- Depress FNC key.
- Depress Feature Access key to check the contents of Feature Access key with LCD. (The LCD automatically returns to clock/calendar display in about 5 seconds.)

**FNC** LED lights.

			1	-	2	5				1	1	-	5	9	8		
--	--	--	---	---	---	---	--	--	--	---	---	---	---	---	---	--	--

**FNC** LED goes off.

			0	5	-	0	-	7	8								
--	--	--	---	---	---	---	---	---	---	--	--	--	--	--	--	--	--

To Clear

- Depress FNC key.
- Depress LNR/SPD key.
- Depress desired Feature Access key.
- Depress FNC key.

**FNC** LED lights.

			1	-	2	5				1	1	-	5	9	8		
--	--	--	---	---	---	---	--	--	--	---	---	---	---	---	---	--	--

**FNC** LED flashes.

--	--	--	--	--	--	--	--	--	--	--	--	--	--	--	--	--	--

- Depress desired Feature Access key.

			0	5	-												
--	--	--	---	---	---	--	--	--	--	--	--	--	--	--	--	--	--

**FNC** LED goes off.

			1	-	2	5				1	1	-	5	9	8		
--	--	--	---	---	---	---	--	--	--	---	---	---	---	---	---	--	--

To Originate (MF operation)

- Depress Feature Access key programmed for DSS/Speed Dial.

**CO/PBX** green LED winks.

			1	:													
--	--	--	---	---	--	--	--	--	--	--	--	--	--	--	--	--	--

**SPKR** LED lights.

			7	8	-	5	1	6	7	5	3	7	0	0	0		
--	--	--	---	---	---	---	---	---	---	---	---	---	---	---	---	--	--

To Originate (KF operation)

- Depress desired CO/PBX line.
- Depress desired Feature Access key.

**CO/PBX** green LED winks.

			1	1													
--	--	--	---	---	--	--	--	--	--	--	--	--	--	--	--	--	--

**SPKR** LED lights.

			7	8	-	5	1	6	7	5	3	7	0	0	0		
--	--	--	---	---	---	---	---	---	---	---	---	---	---	---	---	--	--

SAMPLE LED INDICATIONS

420.22 Nesting Dial

Up to five Speed Dialing buffers can be stored into one Speed Dial buffer. These numbers can be sent successively by depressing the LNR/SPD key and then dialing the Speed Dial buffer number. Confirm if desired Speed Dial buffer number has already been programmed.

To Set

- Depress **FNC** key.
- Depress **LNR/SPD** key.
- Dial vacant buffer number.
- \*Depress **HOLD** key.
- Dial desired Speed Dialing buffer number (When successive programming is needed, go back to \*).
- Depress **FNC** key.

To Verify

See section 420.20 of this manual (Speed Dialing).

To Originate

See section 420.20 of this manual (Speed Dialing).

**NOTE:** Some combinations of Nesting Dial can not be performed.

Possible Combinations

Speed Dialing buffer A

<b>B</b>	<b>C</b>	<b>D</b>	<b>E</b>	<b>F</b>
----------	----------	----------	----------	----------

: Up to 5 (buffers can be set)

**FNC** LED lights.

		1	-	2	5					1	1	-	5	9	9				
--	--	---	---	---	---	--	--	--	--	---	---	---	---	---	---	--	--	--	--

**FNC** LED blinks.

--	--	--	--	--	--	--	--	--	--	--	--	--	--	--	--	--	--	--	--	--

0	1																			
---	---	--	--	--	--	--	--	--	--	--	--	--	--	--	--	--	--	--	--	--

0	1																			
---	---	--	--	--	--	--	--	--	--	--	--	--	--	--	--	--	--	--	--	--

0	1																			
---	---	--	--	--	--	--	--	--	--	--	--	--	--	--	--	--	--	--	--	--

**FNC** LED goes off.

--	--	--	--	--	--	--	--	--	--	--	--	--	--	--	--	--	--	--	--	--

SAMPLE LED INDICATIONS

SAMPLE LED INDICATIONS

Impossible Combinations

Speed Dialing buffer A

A
---

: Speed Dialing buffer A cannot be stored within its own buffer.

Speed Dialing buffer A

B
---

Speed Dialing buffer B

C
---

Speed Dial buffer B cannot be stored in buffer A because buffer B already contains a Nesting Dial sequence (C).

SAMPLE LED INDICATIONS

SAMPLE LCD INDICATIONS

420.23 Station Background Music

To Set

- Depress FNC key.
- Dial access code 93 for BGM.
- Depress FNC key.
- Background Music is heard over station speaker.

To Cancel

- Depress FNC key.
- Dial access code 93 for BGM.
- Depress FNC key.
- Make sure that Background Music is no longer heard over station speaker.

**FNC** LED lights.

1-25 11-59A

**FNC** LED blinks.

b R C 9 n d a n

**FNC** LED goes off.

**FNC** LED lights.

1-25 11-59A

**FNC** LED blinks.

b R C 9 n d a F F

**FNC** LED goes off.

420.24 Ringing Tone Variation Assignment

- Depress FNC key.
- Depress LNR/SPD key.
- Dial \*.
- Dial 1.
- Dial ( ).

Tone Frequency:

- (1) = (low)
- (2) = (medium)
- (3) = (high)

- Depress FNC key.

SAMPLE LED INDICATIONS

- FNC** LED lights.
- FNC** LED flashes.
- FNC** LED goes out.
- SPKR** LED blinks.
- FNC** LED blinks.

- FNC** and **SPKR** LED's go out.

SAMPLE LCD INDICATIONS

```

  1-25 11-598
  :
  109 855.90
  
```

```

  1-25 11-598
  
```

SAMPLE LED INDICATIONS

SAMPLE LED INDICATIONS

420.25 Ringing Assignment

- Depress FNC key.
  - Depress LNR/SPD key.
  - Dial \*.
  - Dial 2.
  - Depress desired CO/PBX line key.
- Ring : CO/PBX red LED on.  
 No Ring : CO/PBX LED off.
- Depress FNC key.

**FNC** LED lights.      1-25 11-59R

**FNC** LED flashes.      1-25 11-59R

**FNC** LED goes out.      1-25 11-59R

**SPKR** LED blinks.      1-25 11-59R

**CO/PBX** red LED lights (or is out).

**FNC** LED blinks.

**CO/PBX** red LED goes out (or lights).

**CO/PBX**, **FNC** and **SPKR** LED's

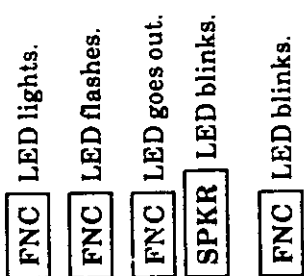
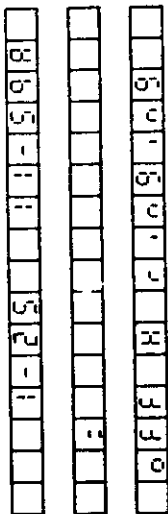
go out.

SAMPLE LED INDICATIONS

SAMPLE LED INDICATIONS

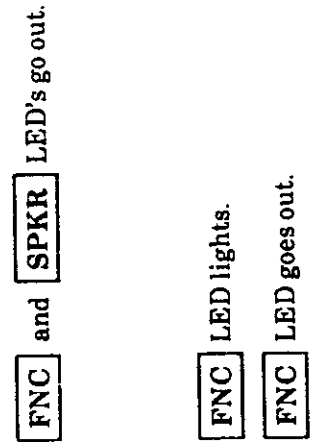
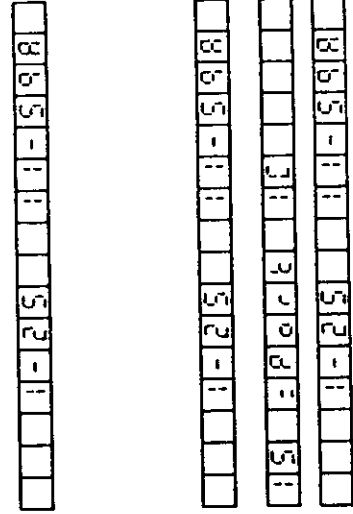
**420.26 Off Hook Ringing Assignment**

- Depress FNC key.
- Depress LNR/SPD key.
- Dial \*.
- Dial 3.
- Dial ( ).
- (0) - (No Ring)
- (1) - (Ring)
- Depress FNC key.



**420.27 Self Extension Number Confirmation  
 (Display phone only)**

- Depress FNC key.
  - Dial 4.
- LCD displays Extension Number and Port Number at right and left sides, respectively LCD goes back to clock/calendar display in about 5 seconds.



SAMPLE LED INDICATIONS

SAMPLE LCD INDICATIONS

420.28 Recording Jack

CO/PBX and intercom calls can be recorded.

- Plug in recording device to the jack dedicated for a recording device in the Key Telephone (ETZ-16D-1 only).

420.29 PC Connection (ETZ-16D-1 only)

**NOTE:** See Chapter 2 in the installation service manual for modem PC connection.

With conversation established (elapsed call timer in display)

- Depress FNC key.
- Dial 7.
- Depress SPKR key then replace handset to return station to monitor mode.

To cancel

With elapsed call timer in display

- Depress FNC key.
- Dial 7.
- Depress SPKR key and release CO/PBX line.

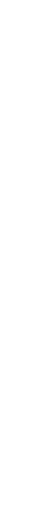
**CO/PBX** green LED winks.



**FNC** LED lights.



**FNC** LED goes off.



**FNC** LED lights.



**FNC** LED goes off.



**CO/PBX** green LED goes out.





SAMPLE LED INDICATIONS

SAMPLE LCD INDICATIONS

430 Attendant Operation

DSS/BLF Consoles can be connected to any type of station (display type is recommended), maximum of 2 Consoles.

430.1 CO/PBX (Outside) Calls

See Section 420.1 of this manual.

430.2 Extension (Internal) Calls

430.2.1 Originating

- Lift handset.
- Depress **DSS** key on the DSS/BLF Console, to call the desired extension.
- If the call is not answered, another **DSS** key can be depressed to place another extension call (chain calling).

<b>ICM</b>	LED lights.	10-11-12-13-14-15-16-17-18-19-20
<b>DSS</b>	red LED lights.	10-11-12-13-14-15-16-17-18-19-20
<b>DSS</b>	red LED goes off and another	10-11-12-13-14-15-16-17-18-19-20
<b>DSS</b>	red LED lights.	10-11-12-13-14-15-16-17-18-19-20

430.2.2 Answering, Hold, Abandoning

See Section 420.2 of this manual.

### 430.3 Attendant Transfer

With call in progress

- Depress **DSS** key on the **DSS/BLF** Console, to Transfer the call; call on nonexclusive hold.
- Voice Announcement or ring back tone is heard.
- Depress **RECALL** key on the Key Telephone before party answers.

When transferring a call to an extension, the line key will remain reserved (on hold) until answered at called extension.

**OR**

- Depress **RECALL** key on the Key Telephone after party answers.

Upon completing Transfer, the line key LED indication changes as follows:

- **CO/PBX** line key:  
I-Hold (green)→Lit (red)

#### SAMPLE LED INDICATIONS

**CO/PBX** green LED winks.



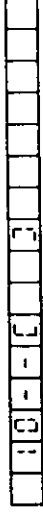
**CO/PBX** green LED winks intermittently.



**DSS** red LED lights.



**CO/PBX** red LED blinks.



**DSS** red LED remains lit.



**CO/PBX** red LED lights.



**DSS** red LED remains lit.



430.4 Originating Internal Zone Paging

- Depress SPKR key.
- Depress Internal Zone Paging key on the DSS/BLF Console.
- Lift handset to page.

ALL Key : DSS/BLF key No. 25  
 Telephones : DSS/BLF key No. 26  
 Zone 1 : DSS/BLF key No. 27  
 Zone 2 : DSS/BLF key No. 27  
 Zone 3 : DSS/BLF key No. 28

SAMPLE LED INDICATIONS

SAMPLE LED INDICATIONS



**SPKR** and **ICM** ( **DSS** )  
 LEDs Light.



**DSS** red LEDs light.

**SPKR** LED goes off.

SAMPLE LED INDICATIONS

430.5 Originating External Zone Paging

- Depress SPKR key.
- Depress External Zone Paging key on the DSS/BLF Console.
- Lift handset to page.

**NOTE :** External Zone Paging key on DSS/BLF Console enables only All Zones.

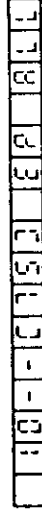
SPKR , ICM and DSS

LED lights.

EP red LED lights.

SPKR LED goes off.

SAMPLE LCD INDICATIONS



SAMPLE LCD INDICATIONS

SAMPLE LED INDICATIONS

430.6 Message Waiting

To Set

- Depress **MSG** key on the DSS/BLF Console. **MSG** LED lights.
- Depress **DSS** key(s) on the DSS/BLF Console where you want to leave a message. **DSS** green LED(s) will light.
- Depress **MSG** key on the DSS/BLF Console. **MSG** LED goes off.

To Cancel

- Depress **MSG** key on the DSS/BLF Console. **MSG** LED lights.
- Depress the **DSS** key(s) on the DSS/BLF Console. **DSS** green LED(s) will go off.
- Depress **MSG** key on the DSS/BLF Console. **MSG** LED goes off.

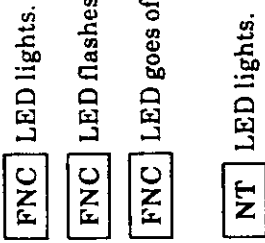
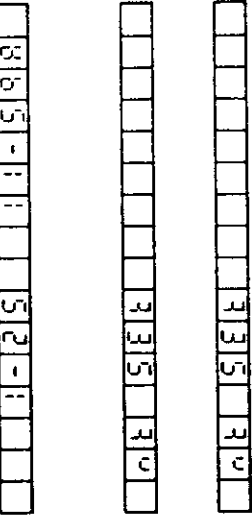
SAMPLE LED INDICATIONS

SAMPLE LCD INDICATIONS

430.7 Night Transfer

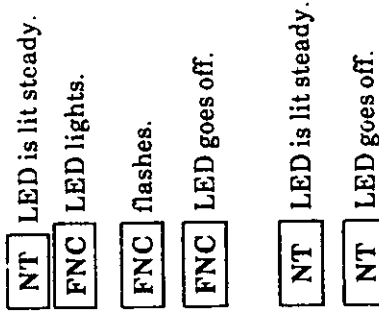
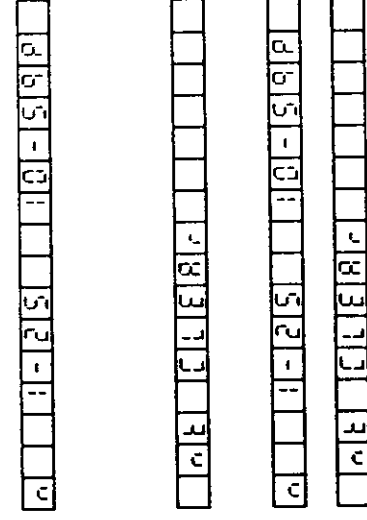
To Set

- a. Dial access
  - Depress **FNC** key during day mode.
  - Dial access code 80 for night mode.
  - Depress **FNC** key.
- b. Using **NT** key
  - Depress **NT** key on the DSS/BLF Console during day mode.



To Cancel

- a. Dial Access
  - Depress **FNC** key during night mode.
  - Dial access code 80 for day mode.
  - Depress **FNC** key.
- b. Using **NT** key
  - During night mode.
  - Depress **NT** key on the DSS/BLF Console.



SAMPLE LED INDICATIONS

SAMPLE LCD INDICATIONS

**430.8 Call Forwarding**

**430.8.1 To Set/Verify**  
 ● See Section 420.19 of this manual.

**430.8.2 To Cancel System Wide Call Forwarding**

- Depress **FNC** key.
- Dial access code 68.
- Depress **FNC** key.

**FNC** LED lights.

**FNC** LED flashes.

**FNC** LED goes off.

C F S Y S C L E R C

**430.8.3 To Cancel System Wide Callback Requests**

- Depress **FNC** key.
- Dial 88.
- Depress **FNC** key.

**FNC** LED lights.

**FNC** LED blinks.

**FNC** LED goes off.

I - 2 S I I - S R R

C H R S Y S C L E R C

**430.9 Programming System Speed Dial**

An Attendant can program, erase and verify System Speed Dial. All Key Telephones can be programmed to verify System Speed Dial by system programming.

See Section 420.20 (Station Speed Dialing) of this manual. For System Speed Dial buffers use numbers (20 - 99).

SAMPLE LED INDICATIONS

**430.10 Clock/Calendar Setting**

The clock/calendar can be set from the Attendant Key Telephone(s) (only Port No. 10 and 11).

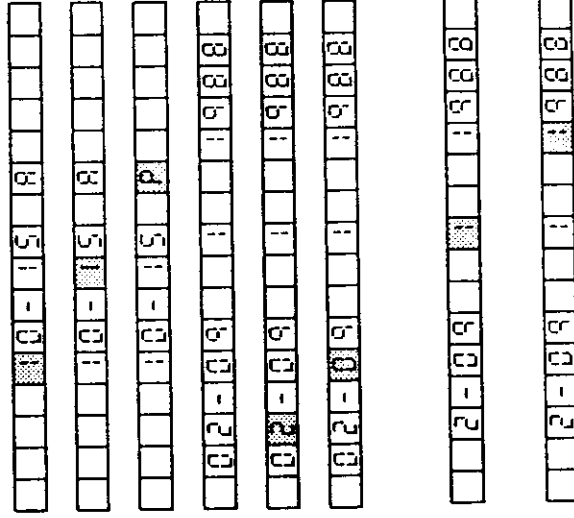
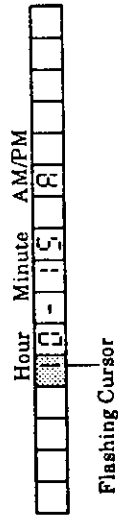
**EXAMPLE:** Monday, February, 9, 1988,  
 10 : 15 A.M

1. Depress FNC key.
2. Dial 9 and #.

- Move the cursor to the desired position by using # or \* button.  
 (Cursor is indicated by blinking character.)

3. Hour Setting : Dial 1, 0
4. Minute Setting : Dial 1, 5
5. AM/PM Setting : Depress **RECALL** key.
6. Depress **HOLD** key for setting the Calendar.
7. Month Setting : Dial 0, 2.
8. Day Setting : Dial 0, 9.
9. Day of Week Setting : Dial 1  
 (See Note)
10. Year Setting : Dial 1, 9, 8, 8

**FNC** LED lights.





SAMPLE LED INDICATIONS

**FNC** LED goes off.

2-09 10-15R

SAMPLE LCD INDICATIONS

11. Depress FNC key.  
**NOTE:** The day of the week is shown by number as follows.

- 0 : SUN      4 : THU
- 1 : MON     5 : FRI
- 2 : TUE     6 : SAT
- 3 : WED

**430.11 Security /Alarm**

Two alarm circuits are provided in the system as an option.

When the alarm circuit is activated, this option provides an audible alarm through all idle Key Telephone speakers.

The alphanumeric display on all Key Telephones with displays indicates which alarm circuit has been activated.

Only the Attendant Key Telephone can cancel the alarm signal.

To cancel the audible signal.

- Depress **FNC** key.
- Dial 78.
- Depress **FNC** key.
- Sensor input goes out.

SECRAL

FNC LED blinks.

FNC LED goes off.

1-25 11-5RR

**NOTE:** The alarm sound can be canceled by this operation, but the visual alarm indication continues until the sensor input returns to a normal condition.

### 440 Feature Access Code List

1. Receiving Volume Control	FNC	→	2
2. Self Station Number Confirmation	FNC	→	4
3. Manual Pause	FNC	→	4
4. Last CO/PBX Number Redial	FNC	→	5
5. Door Lock Release	FNC	→	6
6. PC Connection	FNC	→	7
7. Call Forward : Set	FNC	→	60
			Transferred TelNo
Cancel	FNC	→	68 / 69
8. Do Not Disturb Set / Cancel	FNC	→	65
9. Security / Alarm Reset	FNC	→	78
10. Night Transfer Set / Cancel	FNC	→	80
11. Callback Request Cancel	FNC	→	88
12. Printer Test	FNC	→	9*
13. Background Music	FNC	→	93
14. FNC Lamp Reset	FNC	→	99

15. Call Pickup :	60
Other Tenant (CO / PBX)	61
Extension in Same Tenant	66
Same Tenant (CO / PBX)	62
16. Call Park / Retrieve to Call park	63
17. Specific CO/PBX Line Seizure	CO/PBX line Number
18. Internal Zone Paging :	70
All Key Telephones	71
Zone 1	72
Zone 2	73
Zone 3	74
Answering (Meet-Me)	
19. External Zone Paging :	75
All Zones	76
Zone 1	77
Zone 2	74
Answering (Meet-Me)	

- 20. PBX Extension Seizure
- 21. Door Phone Call/Answer :
  - Door Phone 1
  - Door phone 2
- 22. CO Line Seizure
- 23. Call for Attendant

## Free Manuals Download Website

<http://myh66.com>

<http://usermanuals.us>

<http://www.somanuals.com>

<http://www.4manuals.cc>

<http://www.manual-lib.com>

<http://www.404manual.com>

<http://www.luxmanual.com>

<http://aubethermostatmanual.com>

Golf course search by state

<http://golfingnear.com>

Email search by domain

<http://emailbydomain.com>

Auto manuals search

<http://auto.somanuals.com>

TV manuals search

<http://tv.somanuals.com>