

OpenSource User Guide for OpenSource Wireless-G Router KWGR614

Summary

This document provides further product information for open source developers who are interested in using this platform to develop their customization applications.

WARNING: Opening the router housing or putting in any customer software on the router will void the warranty on your router

Specifications

This section describes the hardware memory specifications and the module and software specifications for the OpenSource Wireless-G Router KWGR614.

Hardware Memory Specifications

Total memory:

- Flash: 4MB
- SDRAM: 16MB

Memory usage of the latest router firmware:

- Flash: 2MB used = 1,804KB (router firmware V1.0.1-10.17WW) + 192KB (Bootloader + BoardInfo + POT + Configuration)
- SDRAM: about 8.5MB (without including the dynamic memory allocation)

Module and Software Specifications

The following table lists the functional modules of the KWGR614 router and the source and versions of the different modules. You can find more information on these functional modules directly from the source of the packages.

Module	Package	Version	Location (directory)
NAT/NAPT	RomeDriver-Realtek	3.6.3	linux-2.4.x/drivers/net/re865x/rtl865x
RIPv1/RIPv2	Copyright 2005, DNI	1.0.0	user/ripd
DHCP server/client	udhcpd/udhcpc of Busybox V1.00-pre2	0.9.10	user/busybox/networking/udhcp
DNS Proxy	Dnrd	2.17.2	user/dnrd-dnshijack

Dynamic DNS	ez-ipupdate	3.0.11b7	user/ez-ipupdate-3.0.11b7
Web Server	BOA	0.94	user/boa
UPNP	Copyright 2005, DNI	1.0.0	user/upnp
Telstra's Big Pond	Bpalogin	V2.0	user/bpalogin
Email	Smtplib	1.0.0	user/smtplib
Schedule	Crontab of Busybox V1.00-pre2	1.0.0	user/busybox/miscutils/crontab.c
PPP/PPPoE	Pppd	2.3.8	user/pppd
PPTP Client	pptp-client	1.3.1	user/pptp-client
Ntpclient	Copyright 2005, DNI	1.0.0	user/ntpclient
Miscellaneous	Copyright 2005, DNI	1.0.0	user/dnutils , user/init
Wireless driver	Copyright Realtek	1.12	linux-2.4.x/drivers/net/wireless/rtl8185
L2TP	l2tpd	0.69	user/l2tpd
Iptables	iptables	1.2.7a	user/iptables

Making a Console Debug Interface for the KWGR614 Router

This section provides instructions on how to make a console interface to a NETGEAR KWGR614 wireless router for the developer's firmware development and debugging.

The following example schematic illustrates using a MAX3232, the RS-232 Line Driver/Receiver from Texas Instruments (TI), to make a console board.

You can download a datasheet for the MAX3232 from the Texas Instruments website at: <http://focus.ti.com/lit/ds/symlink/max3232.pdf>.

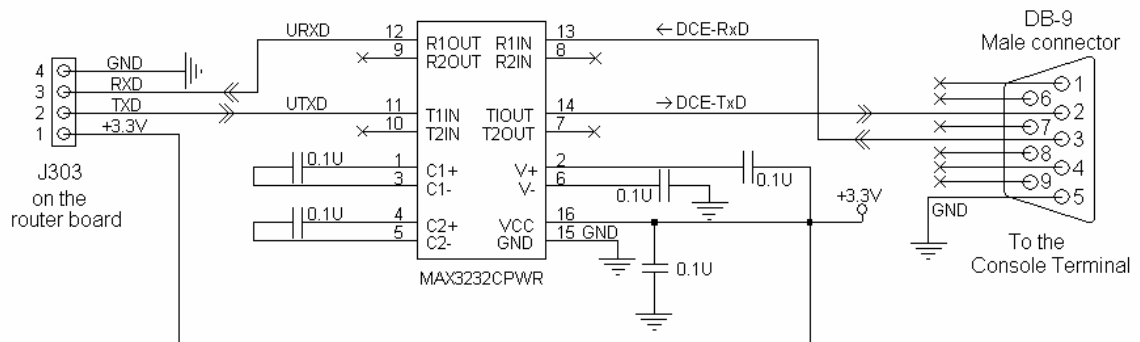

KWGR614 Console Interface

Note: The DB9 (male) connector is wired as a DCE (think of this as a peripheral serial port), and can be connected directly to the serial port on a host PC. This gives you access to the built-in serial console on the router (using the protocol of 38400bps, 8 data bits, none parity, 1 stop bit, without flow control).

To make a console debug interface for the KWGR614 router:

Connect the console board to the pin header (J303) on the router board.

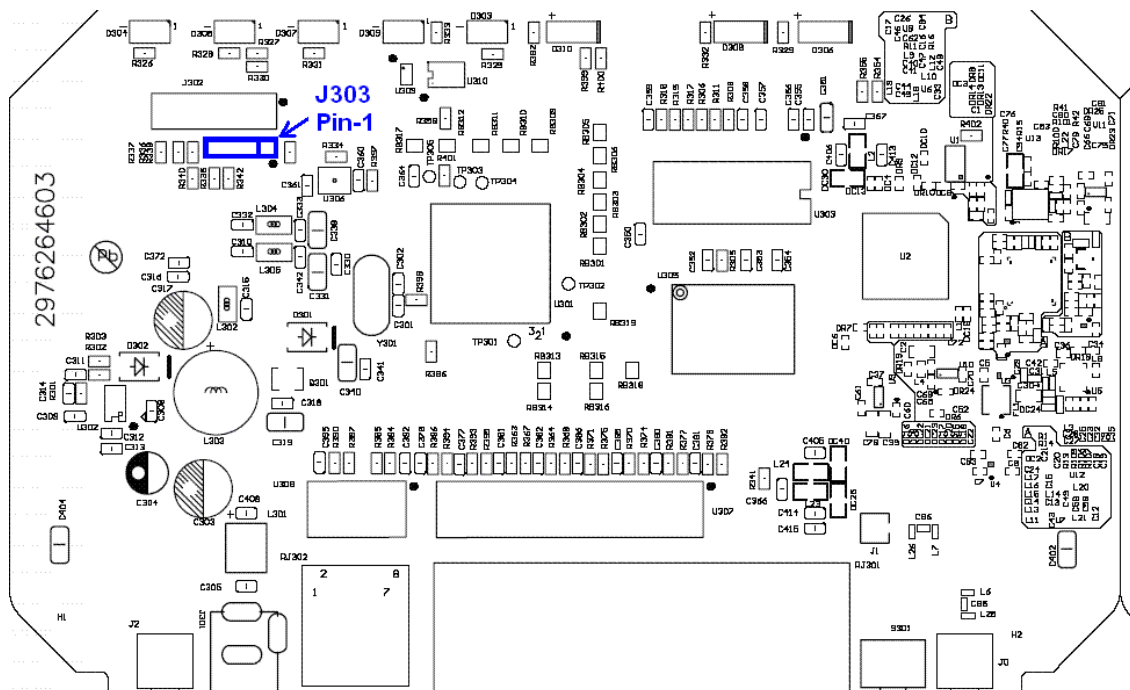

The pin-out of J303 on the KWGR614 board is as follows:

- Pin 1: VDDH (3.3V)
- Pin 2: TxD
- Pin 3: RxD
- Pin 4: GND (Ground)

There are third-party vendors who provide compatible console boards, such as the AD233AK/AD233BK RS232 adapter kits at:

http://www.compsys1.com/workbench/On_top_of_the_Bench/Max233_Adapter/max233_adapter.html

Make sure the third-party adapter board is connected correctly to the corresponding pins of J303 on the router board.

Source Code and Executable

This section describes the steps and procedures that are required to download the source code, install the toolchain, compile and link the existing source code, and develop the user applications for the KWGR614 Router.

Note: The procedures in this guide were performed on Suse Linux 10.1.

1. Download KWGR614_V1.0.1_10.17WW_gpl_package.zip from the NETGEAR Open Source web site at: http://kbserver.netgear.com/kb_web_files/open_src.asp.

Note: V1.0.1_10.17 is the firmware version number. WW denotes Worldwide. You can download other versions of this document, for example, North America (NA).

2. Unzip KWGR614_V1.0.1_10.17WW_gpl_package.zip (or the version you downloaded). The zip file contains the following files:
 - o KWGR614_README.txt (the *OpenSource User Guide*)
 - o KWGR614_V1.0.1_10.17WW_src.tar.bz2
 - o toolchain_mips_20050831.tar.bz2
3. Unpack the source code in `tar -xvf KWGR614_V1.0.1_10.17WW_src.tar.bz2`. This creates a sub-directory KWGR614_XXX/. (XXX -> V1.0.1_10.17WW (XXX denotes the version number.)

We recommend that you read the following documents in this directory before you proceed.

- /vendors/Documentation/KWGR614_README.txt
- /SOURCE
- /README
- /Documentation/Adding-User-Apps-HOWTO
- /Documentation/Addid-Platforms-HOWTO

4. Install the Tool chain in the root directory by typing:

```
# cd/  
mkdir uclibc  
# cd uclibc  
# tar jxvf toolchain_mips_20050831.tar.bz2  
# mv toolchain_mips.pv.0831 toolchain_mips
```

Note: Root user permissions may be required to create the uclibc directory and install the tool chain into the root directory of the file system.

5. Compile.

- a. Change the working directory to KWGR614_XXX/.
- b. Type `make menuconfig`, and customize your kernel config options, as follows:

```
Target Platform Selection --->
[ * ] Customize Kernel Settings (NEW)
Exit, Exit, Save configuration? yes
Exit, Save configuration? yes
```

Note: If you are building runtime image for the first time, be sure to save the configuration when leaving `make menuconfig`, even if no change is made to the default settings.

- c. Type `make dep`.
 - d. (Optional) If you need to customize busybox, go to KWGR614_XXX/user/busybox/, and type `make menuconfig` to select the user level application you need. Then go back to KWGR614_XXX/, and type `make dep` again. This updates all dependencies.
6. Type `make`. This builds the kernel, user apps, and create image file `run.bix` under KWGR614_XXX/images/ directory.

After compiling and linking the existing source code already provided, you can now upload the KWGR614_XXX/images/run.bix file directly to the router after connecting the router to your PC and using the Router firmware Upgrade page on the Router Web GUI.

Developing Custom Applications on the OpenSource Router

This section describes how to develop custom applications on this router.

Setting the Version String

Set your custom version string in the file `user/dni/nvram_realtek.c` by defining `OS_VERSION`. Be certain to remove any duplicate definition.

```
user/dni/nvram_realtek.c
```

```
#define OS_VERSION "V1.01.01 Custom"
```

Note: You can remove the country suffix from the version string by redefining EXTENSION.

user/dni/nvram_realtek.c

```
#if 1
#ifdef EXTENSION
#undef EXTENSION
#endif
#define EXTENSION ""
#endif
```

New NVRAM Parameters

1. Define the structure of the parameter.

user/boa/src/rtl865x/board.h

```
#define MAX_QUESTION_LENGTH 64
typedef struct exampleParam_s
{
    char question[MAX_QUESTION_LENGTH];
    int answer;
} exampleParam_t;
```

2. Add the new parameter to the main parameter structure to include it in the configuration set.

user/boa/src/rtl865x/board.h

```
typedef struct romeCfgParam_s
{
    . . .
    exampleParam_t exampleParam;
} romeCfgParam_t;
```

3. Create get/set functions for the parameter.

user/dniutil/nvram_realtek.c

```
char *
nvram_get_example_question (char *name)
{
    DPRINTF("nvram_get(\"%s\")\n", name);
    sprintf(str, "%s", pRomeCfgParam->exampleParam.question);
    return (str);
}

int
nvram_set_example_question(char *name, char *value)
{
    DPRINTF("nvram_set(\"%s\", \"%s\")\n", name, value);
    strncpy(pRomeCfgParam->exampleParam.question, value, \
        sizeof(pRomeCfgParam->exampleParam.question));
    return 1;
}

char *
nvram_get_example_answer (char *name)
{
    DPRINTF("nvram_get(\"%s\")\n", name);
    sprintf(str, "%d", pRomeCfgParam->exampleParam.answer);
    return (str);
}

int
nvram_set_example_question(char *name, char *value)
{
    DPRINTF("nvram_set(\"%s\", \"%s\")\n", name, value);
    pRomeCfgParam->exampleParam.answer = atoi(value);
    return 1;
}
```

4. Add the get/set handlers to the NVRAM handler table.

user/dniutil/nvram_realtek.c

```
struct ej_nvram_handler nvram_handlers[] =
{
    . . .
    {"example_question", nvram_get_example_question,
nvram_set_example_question},
    {"example_answer", nvram_get_example_answer,
nvram_set_example_answer},
    { NULL, NULL, NULL },
};
```

5. Declare an instance of the parameter for runtime memory use.

user/boa/src/dni/board.c

```
exampleParam_t          ramExampleParam; //nvram example
```

6. Define default values for the parameter.

user/boa/src/dni/board.c

```
// nvram example
exampleParam_t exampleParamDefault[1] =
{
    {
        "What is the meaning of life, the universe, and
everything?",
        42
    }
};
```

7. Define the initialization function.

user/boa/src/dni/board.c

```
uint32 example_init(void)
{
    /* read cfg from cfgmgr */
    if (cfgmgr_read(CFGMGR_TABID_EXAMPLE, \
        (void*)&(pRomeCfgParam->exampleParam), \
        sizeof(struct exampleParam_t))!=0)
    {
        printf("example_init: call cfgmgr_read fail\n");
        /* take proper actions */
        return NOT_OK;
    }

    //printf("example_init\n");
    return OK;
} /* end example_init */
```

8. Add the function to system initialization.

user/boa/src/dni/board.c

```
uint32 sysInit(void)
{
    . . .
    /* init nvram example */
    example_init();
    . . .
} /* end sysInit */
```

9. Add an ID to the configuration management table and to the control table.

user/boa/src/rtl865x/rtl_board.h

```
enum _board_cfgmgr_tabId_e {
    . . .
    CFGMGR_TABID_EXAMPLE,
    CFGMGR_TABID_MAX
};
```

user/boa/src/dni/board.c

```
static _board_cfgmgr_ctrl_t _board_cfgmgr_ctrlTbl[CFGMGR_TABID_MAX+1]
=
{
    . . .
    {CFGMGR_TABID_EXAMPLE, exampleParamDefault,
    (sizeof(exampleParamDefault))},
    {CFGMGR_TABID_MAX, NULL, 0}
};
```

10. Create a save function for the parameter.

user/boa/src/dni/board.c

```

int example_cfg_save(void)
{
    cfgmgr_write(CFGMGR_TABID_EXAMPLE, \
                (void*)&(pRomeCfgParam->exampleParam), \
                sizeof(exampleParam_t));
    cfgmgr_task();
    return 1;
}

```

11. Add the parameter to the NVRAM commit function.

user/boa/src/dni/board.c

```

int nvram_commit(void)
{
    . . .
    cfgmgr_write(CFGMGR_TABID_EXAMPLE, \
                (void*)&(pRomeCfgParam->exampleParam), \
                sizeof(exampleParam_t));
    cfgmgr_task();
    return 1;
}

```

12. Clean and rebuild userspace after any changes to board.h.

At the shell prompt, type:

```
work> cd user; make clean; cd ../; make
```

Web Page Integration

The boa web server is used. Custom web pages are integrated at:
user/boa/src/www_WW/

1. Create the main page in the above directory. Use `<% nvram_get ("variable name") ; %>` to insert the value of an NVRAM variable.

user/boa/src/www_WW/example.html

```
<html>
<head>
<meta http-equiv="content-type" content="text/html; charset=ISO-8859-1">
<META http-equiv='Pragma' CONTENT='no-cache'>
<META HTTP-EQUIV="Cache-Control" CONTENT="no-cache">
<title>Router Customization Example</title>
<link rel="stylesheet" href="/form1.css" type="text/css">
<script language="javascript" type="text/javascript">
<!-- hide script from old browsers
function loadhelp(fname)
{
    if(top.helpframe != null) {
        top.helpframe.location.href="help/help"+fname+".html"
    }
}
//-->
</script>
</head>
<body bgcolor="#ffffff" leftmargin="0" topmargin="0" marginwidth="0"
marginheight="0" onload="loadhelp('_example');">
Q: <% nvram_get("example_question"); %><br>
A: <% nvram_get("example_answer"); %>
</body>
</html>
```

2. Create the help file in the help directory. Name the file the same as the main page with a "help_" prefix.

user/boa/src/www_WW/help/help_example.html

```

<html>
<head>
<META name="description" content="KWGR614">
<META http-equiv="Content-Type" content="text/html; charset=iso-8859-1">
<META http-equiv="Pragma" content="no-cache">
<META HTTP-equiv="Cache-Control" content="no-cache">
<title>Help</title>
<link rel="stylesheet" href="help.css">
</head>
<body bgcolor="#0099cc" >
    <h1>Example Help</h1>
    <p>This is an example web page showing how to get a parameter
from nvram.
</p>
</body>
</html>

```

3. Add a link to the Admin page menu by editing the contents file and including a reference to the new web page.

```
user/boa/src/www_WW/contents1.html
```

```

. . .
<table>
    <tr>
        <td valign="top">
            
        </td>
        <td>
            <a href="example.html"
target="formframe">Example</a>
        </td>
    </tr>
. . .

```

Device Recovery Procedure

If the uploaded firmware crashes the router, use the procedure in this section for device recovery.

1. Power off the unit.
2. Press and hold the RESET button on the rear panel.
3. Power on to reboot the unit.
4. Monitor the Test LED, and keep holding the RESET button until the Test LED changes from blinking to steady ON (which means the boot loader has entered the TFTP recovery mode).
5. Connect the PC (configured with static IP address 192.168.1.x) to the LAN port of the unit.
6. Transmit the working firmware image file to the unit (the firmware can be downloaded from Netgear support website).
 - o For a Windows PC, type the DOS command:
`tftp -i 192.168.1.1 PUT KWGR614_XXX.bix`
 - o For a Linux PC, type the command:
`tftp -m binary 192.168.1.1 -c put KWGR614_XXX.bix`
where 192.168.1.1 is the unit's LAN IP address and KWGR614_XXX.bix is the firmware image file to transmit.
7. Monitor the Test LED. When it starts blinking, the recovery procedure is complete.
8. Power cycle to reboot KWGR614.

Note: Repeat the above steps if the procedure is interrupted or fails.

Conclusion

This guide provides information including the hardware memory spec, the software modules, the console interface for code debugging and development, guide for building the source code, the example program, and the device recovery procedure. For further info please contact Netgear customer support.

WARNING: Opening the router housing or putting in any customer software on the router will void the warranty on your router

January 16, 2007

Copyright © 2007 NETGEAR®

Free Manuals Download Website

<http://myh66.com>

<http://usermanuals.us>

<http://www.somanuals.com>

<http://www.4manuals.cc>

<http://www.manual-lib.com>

<http://www.404manual.com>

<http://www.luxmanual.com>

<http://aubethermostatmanual.com>

Golf course search by state

<http://golfingnear.com>

Email search by domain

<http://emailbydomain.com>

Auto manuals search

<http://auto.somanuals.com>

TV manuals search

<http://tv.somanuals.com>