

NETGEAR

MODEL
FS2105/FS2108

Fast Ethernet Switch Installation Guide

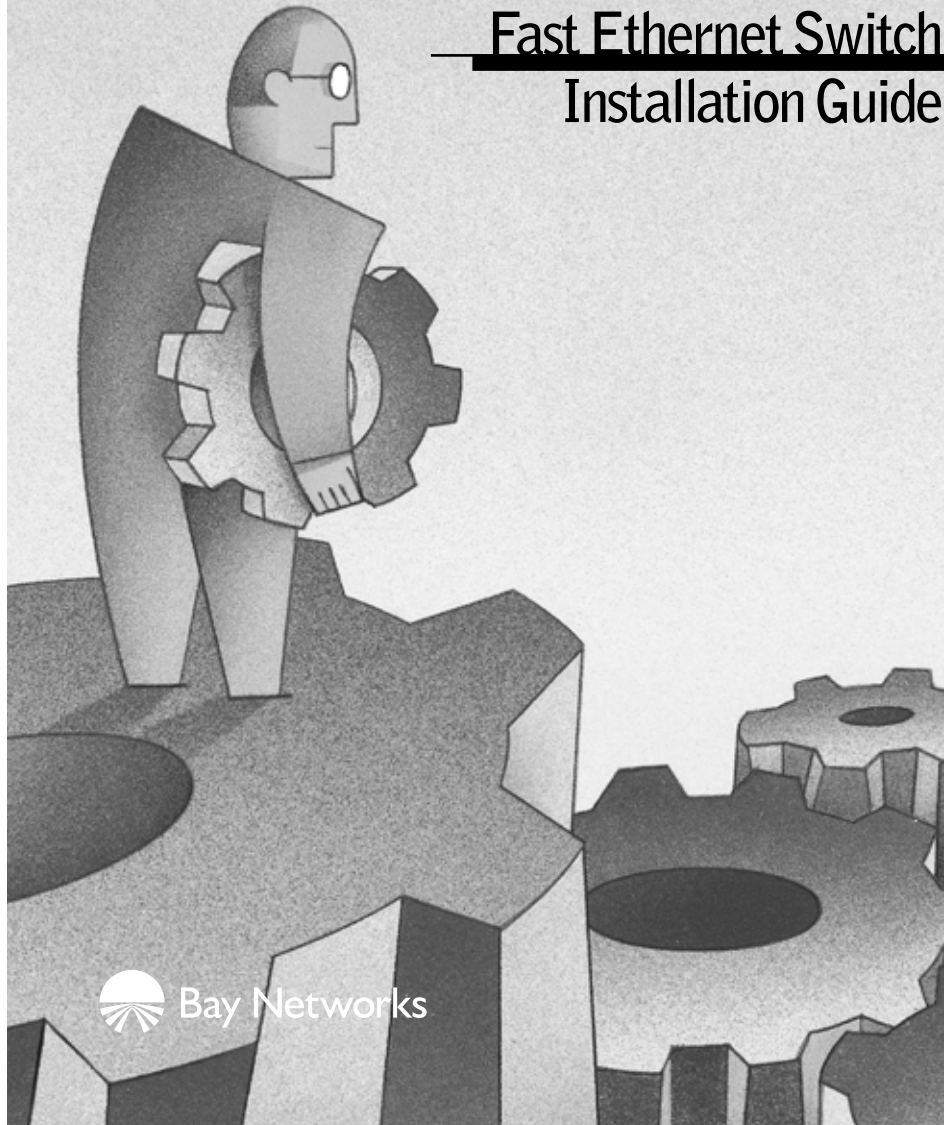

 Bay Networks



Introduction

The NETGEAR™ Model FS2105 Fast Ethernet Switch and Model FS2108 Fast Ethernet Switch simplify 10/100 megabits per second (Mbps) switching technology so that small businesses can enjoy the same high-performance networking facilities that the corporate users enjoy. These switches boost network throughput, while preserving your investment, so that there is no need to replace installed cabling, desktop software, or hardware.



Product Illustration

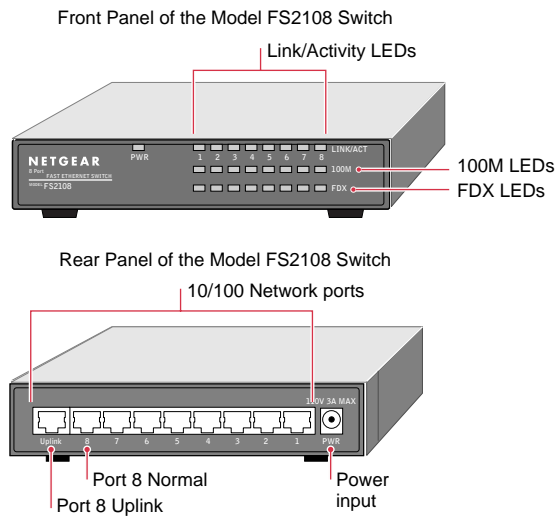

9608FA



Note: The Model FS2105 Fast Ethernet Switch is similar to the Model FS2108 Fast Ethernet Switch, with the exception of three fewer RJ-45 ports and LEDs.

LEDs

This table describes the activity for LEDs on either the Model FS2105 switch or the Model FS2108 switch.

Label	Color	Activity	Description
Pwr (power)	Green	On Off	Power is supplied to the switch. Power is disconnected.
Link/ACT	Green	On Blinking	Port connection is good. This port is receiving or transmitting data.
100M	Green	On Off	This port is operating at 100 Mbps. This port is operating at 10 Mbps.
FDX	Green	On Off	The port is operating in full-duplex mode. The port is operating in half-duplex mode.

Network Ports

Ports 1 through 4 for the Model FS2105 Fast Ethernet Switch and ports 1 through 7 for the Model FS2108 Fast Ethernet Switch are permanently configured for normal wiring for connection to a PC or a router. They are all 10/100 Mbps ports.

Normal/Uplink Ports

There are two port 5s for the Model FS2105 Fast Ethernet Switch and two port 8s for the Model FS2108 Fast Ethernet Switch. These ports are used as follows:

- Port 5 Normal (or port 8 Normal) is for normal (MDI-X) wiring for direct connection to a PC or router.
- Port 5 Uplink (or port 8 Uplink) is for uplink (MDI) wiring for connection to a hub or a switch.



Note: Port 5 Normal (or port 8 Normal) and port 5 Uplink (or port 8 Uplink) can have only one connection at a time. If both ports are connected at the same time, they become disabled.



Applications

PC Workgroup

Both the Model FS2105 Fast Ethernet Switch and the Model FS2108 Fast Ethernet Switch can be used as a desktop switch to build a small network that enables users to have 100 Mbps access to a file server. Compared with a hub, where the network bandwidth is shared among all users, the Model FS2105 switch or the Model FS2108 switch provides dedicated 10 or 100 Mbps bandwidth to each PC.

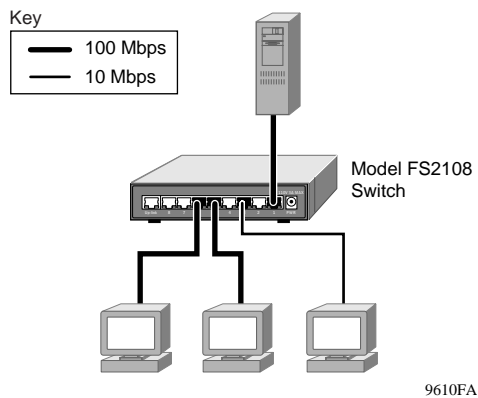

With a full-duplex adapter card installed in the server, a 200 Mbps connection is possible on the port where the server or PC is connected.

Expanded Workgroup

Both the Model FS2105 Fast Ethernet Switch and the Model FS2108 Fast Ethernet Switch can be used to connect multiple PC workgroups.

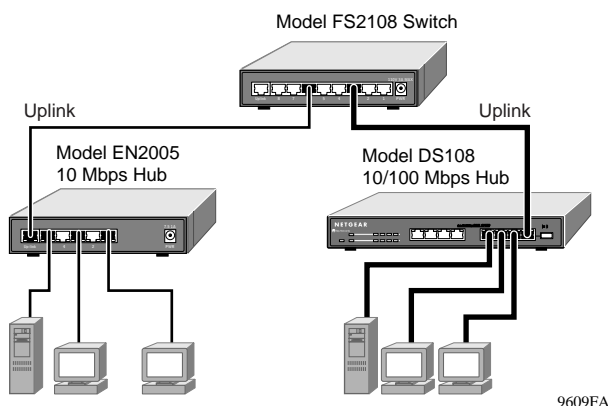

1 Installing the Switch

There are three ways to install either the Model FS2105 Fast Ethernet Switch or the Model FS2108 Fast Ethernet Switch:

- Desktop
- Magnetic mount (see “Inserting the Magnet”)
- Wall mount

You do not need tools for desktop or magnetic mount installation, but you do need a Phillips screwdriver for wall mount installation.

Wall Mounting the Switch

1. **Measure the distance between the mounting holes on the back of the switch.**
2. **Mark the wall to match the location of the mounting holes.**
3. **At the marked location, insert the two screws that you received in your package contents.**



Note: For all three installations:

- Choose a location that is near the devices to be connected.
- Make sure you are close to an electrical outlet.
- Be sure to leave at least 2 inches of space all around the switch for ventilation.

Magnet Mounting the Switch

Inserting the Magnet

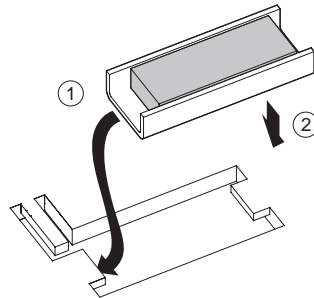

9640FA

Removing the Magnet

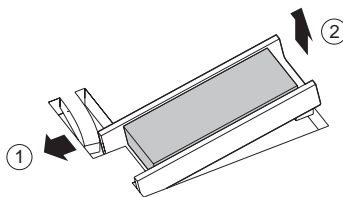

9641FA

2 Connecting the Network

To connect devices to the switch:

1. **Connect the devices to the 10/100 Mbps ports on the switch, using category 5 UTP cable with an RJ-45 plug.**



Note: Ethernet specifications limit the total cable length between your PC and the switch to 328 feet (100 meters).

2. **Connect the switch for specific devices:**
 - To connect to a PC or router, use port 5 Normal (or port 8 Normal). This connection is considered “normal.”
 - To connect to a hub or another switch, use port 5 Uplink (or port 8 Uplink). This connection is considered “uplink.”
3. **Connect one end of the DC power adapter cable to the power outlet on the rear panel of the switch and the other end of the power adapter cable to the wall outlet. Verifying**



Verifying Installation

When power has been applied to the switch:

- The green Pwr (power) LED on the front panel is on.
- The green Link/Activity LED on each connected port is on.

When the switch is connected and operating, refer to the table in “LEDs” for information about the LEDs and their activity.



Troubleshooting Information

Symptom	Cause	Solution
Green 100M LED is off.	Port is operating in 10 Mbps mode.	Make sure that the adapter card is capable of and set for 100 Mbps operation.
Green Link LED is on and Green FDX LED is off when connected to a full-duplex network.	Port is operating in half-duplex mode.	Make sure that the connected device is capable of full-duplex transmission, using autosensing. The Model FS2105 switch and the Model FS2108 switch will not support a full-duplex link that is not using autosensing.
Link is off on port 5 (or 8).	Port 5 (or 8) is not connected correctly.	Make sure that only one port 5 (or 8) is connected, not both (Uplink or Normal). Normal port 5 (or 8) is connected to a PC or router. Uplink port 5 (or 8) is connected to a hub or switch. Make sure that you are using standard, Category 5, straight-through UTP cabling.
Link/Activity LED is off on a connected port.	Port connection is not functioning.	Make sure that the attached device is powered and there is a proper UTP connection. Make sure that the network adapter card installed in the PC is working. Verify that the network adapter card is operating at the proper speed (10 Mbps or 100 Mbps). Make sure that the proper cable is installed. Check for miswired cable pairs or loose connectors. For 100 Mbps operation, only Category 5 or better grade cable should be used. For 10 Mbps operation, Category 3 cable can be used. Make sure that the length of the UTP cable from the switch to the device does not exceed 328 feet (100 meters).



Technical Specifications

Type	Specification
Standards	IEEC 802-3, 10BASE-T Ethernet
Compatibility	IEEC 802-3u, 100BASE-T Ethernet IEEE 802.3x Flow control; back-pressure support Compatible with major network software, including Windows®, NetWare, Mac OS, and Linux
Network Interface	RJ-45 connector for 10BASE-T or 100BASE-TX Ethernet interface
Power	Model FS2105 switch: 5.5 w max. Model FS2108 switch: 8.0 w max.
Physical Specifications	
Dimensions:	177 x 118 x 32 mm (for both switches)
Weight:	1.25 lb; 0.6 kg
Electromagnetic Compliance	CE mark, commercial; FCC Part 15 Class A; EN 55 022 (CISPR 22), Class A; VCCI Class A; and C-Tick
Warranty	
Switch:	Limited lifetime warranty 5 years
Power Adapter:	

For more information about customer support and technical specifications, refer to the NETGEAR Web site:

<http://www.NETGEARinc.com/products>

© 1999 by NETGEAR, Inc. All rights reserved.

Trademarks

NETGEAR is a trademark of NETGEAR, Inc.

Microsoft and Windows are registered trademarks of Microsoft Corporation.

All other trademarks and registered trademarks are the property of their respective owners.

Statement of Conditions

In the interest of improving internal design, operational function, and/or reliability, NETGEAR reserves the right to make changes to the product described in this document without notice.

NETGEAR does not assume any liability that may occur due to the use or application of the product(s) or circuit layout(s) described herein.

Certificate of the Manufacturer/Importer

It is hereby certified that the NETGEAR Model FS2105 Fast Ethernet Switch and Model FS2108 Fast Ethernet Switch have been suppressed in accordance with the conditions set out in the BMPT-AmtsblVfg 243/1991 and Vfg 46/1992. The operation of some equipment (for example, test transmitters) in accordance with the regulations may, however, be subject to certain restrictions. Please refer to the notes in the operating instructions.

Federal Office for Telecommunications Approvals has been notified of the placing of this equipment on the market and has been granted the right to test the series for compliance with the regulations.

Federal Communications Commission (FCC) Compliance Notice: Radio Frequency Notice

This device complies with part 15 of the FCC Rules. Operation is subject to the following two conditions:

- This device may not cause harmful interference.
- This device must accept any interference received, including interference that may cause undesired operation.

Note: This equipment has been tested and found to comply with the limits for a Class B digital device, pursuant to part 15 of the FCC Rules. These limits are designed to provide reasonable protection against harmful interference in a residential installation. This equipment generates, uses, and can radiate radio frequency energy and, if not installed and used in accordance with the instructions, may cause harmful interference to radio communications. However, there is no guarantee that interference will not occur in a particular installation. If this equipment does cause harmful interference to radio or television reception, which can be determined by turning the equipment off and on, the user is encouraged to try to correct the interference by one or more of the following measures:

- Reorient or relocate the receiving antenna.
- Increase the separation between the equipment and receiver.
- Connect the equipment into an outlet on a circuit different from that to which the receiver is connected.
- Consult the dealer or an experienced radio/TV technician for help.

EN 55 022 Declaration of Conformance

This is to certify that the NETGEAR Model FS2105 Fast Ethernet Switch and Model FS2108 Fast Ethernet Switch are shielded against the generation of radio interference in accordance with the application of Council Directive 89/336/EEC, Article 4a. Conformity is declared by the application of EN 55 022 Class B (CISPR 22).

Canadian Department of Communications Radio Interference Regulations

This digital apparatus (NETGEAR Model FS2105 Fast Ethernet Switch and Model FS2108 Fast Ethernet Switch) does not exceed the Class B limits for radio-noise emissions from digital apparatus as set out in the Radio Interference Regulations of the Canadian Department of Communications.

Règlement sur le brouillage radioélectrique du ministère des Communications

Cet appareil numérique (NETGEAR Model FS2105 Fast Ethernet Switch et Model FS2108 Fast Ethernet Switch) respecte les limites de bruits radioélectriques visant les appareils numériques de classe A prescrites dans le Règlement sur le brouillage radioélectrique du ministère des Communications du Canada.

NETGEAR

NETGEAR, Inc.
A Bay Networks Company
4401 Great America Parkway
Santa Clara, CA 95054 USA
Phone: 888-NETGEAR
<http://www.NETGEARinc.com>



Free Manuals Download Website

<http://myh66.com>

<http://usermanuals.us>

<http://www.somanuals.com>

<http://www.4manuals.cc>

<http://www.manual-lib.com>

<http://www.404manual.com>

<http://www.luxmanual.com>

<http://aubethermostatmanual.com>

Golf course search by state

<http://golfingnear.com>

Email search by domain

<http://emailbydomain.com>

Auto manuals search

<http://auto.somanuals.com>

TV manuals search

<http://tv.somanuals.com>