

# Wireless Firewall Router

54Mbps WIRELESS FIREWALL VPN ROUTER WITH 10/100 4-PORT SWITCH

# Router



Active  
SPI & DoS  
Firewall

5 VPN  
End  
Points

54  
Mbps  
Wireless

*All-in-one advanced firewall, 2.4GHz wireless & VPN router*

The NB5540 is designed to get Australians sharing the Internet easily, safely and wirelessly – without the need for technical expertise. Fully featured to cover a wide range of uses, it includes an Active Firewall to help protect your computers from attack and 5 VPN endpoints so you can connect to the office from home or anywhere in the world via the Internet.

#### WIRED AND WIRELESS – QUICKLY

NetComm's NB5540's integrated 802.11g wireless AP and 4-port 10/100 Mbps switch make it quick and easy to deploy wireless and wired LAN without the extra costs of a wireless access point, hub or switch. The NB5540's efficient antenna has a range of up to 150 meters and provides up to 128 bit WEP data encryption for high-level security.

#### KEEP YOUR OLD WIRELESS EQUIPMENT

If you already use 11Mbps wireless equipment it can still be used with the NB5540 because the 802.11g standard is backwards compatible with 802.11b

#### EASY TO USE

NetComm's web-based One-Page-Setup means you do not need to install any drivers on your computer. All you need is a web browser, such as Internet Explorer, on any computer using any Operating System and you will be able to configure your connection.

#### SAFELY SHARE YOUR INTERNET CONNECTION

With just one ISP account and a Cable or ADSL modem, you can allow up to 253 Windows®, Macintosh or any other Ethernet-enabled computers safe access to the internet to send and receive emails, surf the web and so on. The Active Firewall will guard against several forms of Denial of Service attacks as well as other types of Hacking by using Stateful Packet Inspection technology (see side panels for details)

#### MAKE USING THE INTERNET EASIER

Universal Plug and Play allows Internet applications such as MSN Messenger© to operate automatically over your firewall without the need for extra configuration.

#### JOIN NETWORKS AND COMPUTERS SECURELY

NetComm's NB5540 supports automatic VPN pass-through to allow any existing VPN client applications to continue to work through your router. Alternatively you can use the five built-in IPsec end points to join to other office networks.

#### FIND FAULTS EASILY

To assist in configuring your network and fault finding, NetComm has added email logging, Ping and Trace Route diagnostics to the NB5540.

### CHECK THESE GREAT FEATURES

- Fast 54Mbps wireless – 802.11g standard for performance you can rely on
- Backwards Compatible with 11Mbps – 802.11b standard
- Easy Web-based setup – specially designed for Australian ADSL & Cable service providers
- Active firewall to protect your PC or network from Internet hackers
- 5 VPN endpoints to securely join networks or computers over the Internet

# Wireless Firewall Router

54Mbps WIRELESS FIREWALL VPN ROUTER WITH 10/100 4-PORT SWITCH



## KEY FEATURES

- One-Page-Setup (covers PPPoE ADSL, Optus cable, DHCP, Telstra Cable Heartbeat, Static IP)
- Active Firewall featuring Stateful Packet Inspection (SPI) and prevention of DoS attack (see side panel)
- 54Mbps wireless IEEE 802.11g standard with auto-selection of optimum data rates
- Network Address Translation (NAT)
- 5 VPN Endpoints
- VPN Pass-through or NAT Traversal (PPTP & IPSec enable/disable)
- Universal Plug and Play
- Ping Diagnostics
- Trace Route Diagnostics
- Back up & Restore Configuration
- Online Log viewer/Syslog/email reporting
- DDNS (Dynamic DNS)
- DHCP Server
- Access Control (ACL's by IP/Mac/URL keyword)
- Port Forwarding
- Special Application (Port Triggering)
- DMZ host/Multi DMZ
- Web-based Administration (configuration)
- Remote Administration (via the Internet configuration)
- SNMP support (4 Communities, Enable/Disable)
- Dynamic Routing (RIP 1 & 2)
- Static Routing
- 1 + 2 Year Warranty (Conditional upon registration online.)

## PACKAGE CONTENTS

- NetComm NB5540 Wireless Firewall Router
- Cat-5 RJ45 Straight-through Ethernet Cable
- Plug Pack 12V DC, 1A
- Installation Guide

## TECHNICAL SPECIFICATIONS

<b>Model Number</b>	NB5540
<b>Standards</b>	IEEE 802.3 (10BaseT), IEEE 802.3u (100BaseTX) IEEE 802.11g Wireless
<b>Ports</b>	WAN: One 10/100 RJ-45 port LAN: Four 10/100 RJ-45 ports All ports with auto cross-over detection Wireless access point
<b>Protocol</b>	TCP/IP, UDP, NAT, DHCP, PPPoE, Heartbeat, CHAP, PAP
<b>Maximum Users</b>	Up to 253 users
<b>Cabling Type</b>	UTP Category 5 or better
<b>IP Setting</b>	WAN: DHCP client, Static IP LAN: DHCP auto-assignment, Static IP
<b>VPN Endpoints – IPSec</b>	<ul style="list-style-type: none"> <li>• Maximum tunnels: up to 5</li> <li>• Local secure group: IP, Subnet or IP range.</li> <li>• Remote secure group: IP, Subnet, IP range, Host or Any</li> <li>• Remote security Gateway: IP, FQDN, Any</li> <li>• Encryption: DES, 3DES or none</li> <li>• Authentication: MD5, SHA or none</li> <li>• Authentication method: Preshared key</li> <li>• Key Management: Auto IKE (PFS or none) or Manual (Encry, Auth, In-SPI, Out SPI)</li> </ul>
<b>VPN Pass-through (NAT traversal)</b>	<ul style="list-style-type: none"> <li>• IPSec enable/disable</li> <li>• PPTP enable/disable</li> <li>• Concurrent sessions: up to 50 dependent on data</li> </ul>
<b>Firewall &amp; Security</b>	<ul style="list-style-type: none"> <li>• Prevent Dos attack: Ping of Death, LAND, IP spoofing, SYN flood, IP Smurfing</li> <li>• Stateful packet inspection (check inbound against outbound)</li> </ul>

- NAT deny external intruder
- ACL Filter: IP, MAC, URL keyword
- Block all: Proxy, Active X, Java /script, cookies, time of day/week

### Management

- Web-based configuration
- Admin Password login
- Fault tolerant TFTP upgradable firmware
- Reset button or Factory default reset
- SNMP

### Inbound Routing

- Special Application (Port Triggering)
- Port Forwarding
- UPnP + Port Translation
- DMZ host / Multi DMZ.

### LAN Routing

- Dynamic (RIP 1 & 2, independent Tx / Rx)
- Static

### Wireless

- 802.11g standard • 802.11b standard
- Auto/manual data rates of 54, 48, 36, 24, 18, 12, 11, 9, 6, 5.5, 2, 1 Mbps
- WEP 64/128bit
- MAC Filtering

**Power** External, 12V DC, 1A

**Environmental** Operating Temp 0 ~ 45°C  
Storage Temp -20 ~ 60°C  
Humidity 0% ~ 90% Non-Condensing

**Certifications** C-Tick (N367)

**Dimensions** 122 (L) x 175 (W) x 31 (H) mm

### System Requirements

Operating system independent – ideal for Windows® Macintosh, Linux & TCP/IP systems

Your Netcomm dealer:

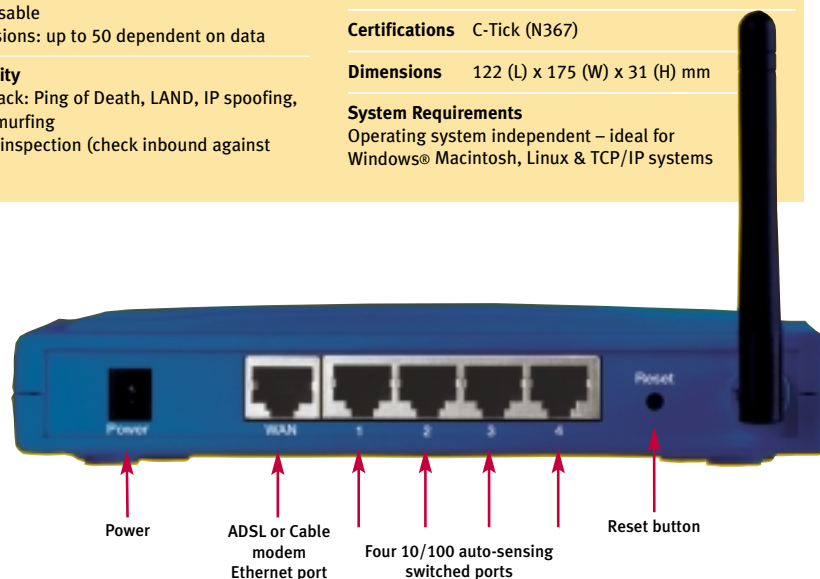

## Free Manuals Download Website

<http://myh66.com>

<http://usermanuals.us>

<http://www.somanuals.com>

<http://www.4manuals.cc>

<http://www.manual-lib.com>

<http://www.404manual.com>

<http://www.luxmanual.com>

<http://aubethermostatmanual.com>

Golf course search by state

<http://golfingnear.com>

Email search by domain

<http://emailbydomain.com>

Auto manuals search

<http://auto.somanuals.com>

TV manuals search

<http://tv.somanuals.com>