

Depth TH 52

- Transducer -

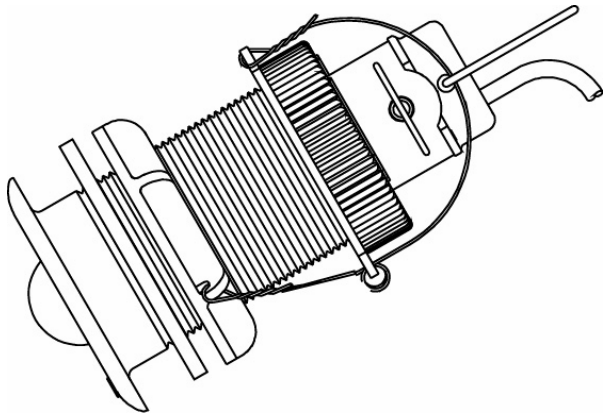

Installation and Operation Manual English



DEPTH TH52

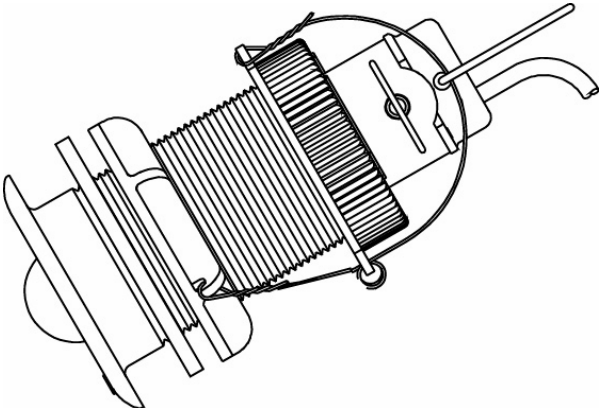

CONTENTS:

1	Applications	4
2	Tools and Materials Needed	4
3	Mounting Location	5
3.1	Acoustic Noise	5
3.2	Placement.....	5
3.3	Boat Types.....	6
4	Installation	7
4.1	Hole Drilling	7
4.2	Bedding.....	8
5	Installing	8
5.1	Checking for Leaks	9
5.2	Blanking Plug.....	9
5.3	Installation in a Cored Fiberglass Hull.....	10
6	CONNECTION TO INSTRUMENT/CONTACTS	11
7	Calibration	11
8	Maintenance	11
8.1	Antifouling Paint.....	11
8.2	Cleaning.....	11
9	TECHNICAL DATA	12

INSTALLATION INSTRUCTIONS

Thru-Hull Depth Transducer

Low Profile, Flush, and Retractable Models

IMPORTANT: Please read these instructions completely before proceeding with the installation. These directions supersede any other instructions in your instrument manual if they differ.

WARNING: NEVER USE SOLVENTS!

Certain cleaners, fuel, paints, sealants, and other products may contain strong solvents, such as acetone, which attack many plastics greatly reducing their strength.

1 Applications

- Plastic housing is recommended for fiberglass or metal hulls only. Never install a plastic thru-hull sensor in a wood hull, since swelling of the wood may overstress the plastic causing a fracture.
- Bronze housing is recommended for fiberglass or wood hulls only. Never install a bronze housing in a metal hull, because electrolytic corrosion will occur.
- Stainless steel housing is recommended for metal hulls to prevent electrolytic corrosion.
- Never install a metal housing in a vessel with a positive ground system.

2 Tools and Materials Needed

Safety goggles

Dust mask

Electric drill with 10mm (3/8") or larger chuck capacity

Drill bit: 3mm or 1/8"

Hole saw (see table on page 1)

Beveled countersink tool for B21, P269, and P314

Countersink tool for B119, P217, and P219

Sandpaper

Mild household detergent or weak solvent (alcohol)

File (installation in a metal hull)

Marine sealant

Additional washer for some aluminum installations

Slip-joint pliers for metal housing

Silicone grease or petroleum jelly (Vaseline®) (retractable units)

Zip-ties

Water-based antifouling paint (**mandatory in salt water**)

Installation in a cored fiberglass hull:

Hole saw for hull interior: (see table on page 1)

Fiberglass cloth and resin (see page 4, #5)

or Cylinder, wax, tape, and casting epoxy (see page 4, #5)

3 Mounting Location

3.1 Acoustic Noise

Acoustic noise is always present and these sound waves can interfere with the operation of the transducer. Background noise from sources such as: waves, fish, and other vessels cannot be controlled. However, carefully selecting the transducer mounting location can minimize the affect of vessel generated noise from the propeller(s) and shaft(s), other machinery, and other echosounders. The lower the noise level, the higher the echosounder gain that can be used.

3.2 Placement

Choose a location where:

- The water flowing across the hull is smoothest with a minimum of bubbles and turbulence (especially at high speeds).
- The transducer will be continuously immersed in water.
- The transducer beam is unobstructed by the keel or propeller shaft(s).
- There is a minimum deadrise angle.
- There is adequate headroom inside the vessel for the height of the housing, tightening the nuts, and removing any insert (see table below).

Model	Minimum Headroom	Outside Hull Hole Saw Size	Inside Hull Hole Saw Size
P17, Retractable	200mm (8")	51mm (2")	60mm (2-3/8")

Caution: Do not mount the sensor:

Near water intake or discharge openings, Behind strakes, fittings, or hull irregularities, Behind eroding paint (an indication of turbulence)

3.3 Boat Types

(see Figure 1)

- **Displacement hull powerboat**—Locate 1/3 aft LWL and 150–300mm (6–12") off the centerline on the side of the hull where the propeller is moving downward.
- **Planing hull powerboat**—Mount well aft, on or near the centerline, and well inboard of the first set of lifting strakes to insure that the transducer is in contact with the water at high speeds. Mount on the side of the hull where the propeller is moving downward.

Outboard and I/O—Mount just forward of the engine(s).

Inboard—Mount well ahead of the propeller(s) and shaft(s).

Step-hull—Mount just ahead of the first step.

Boat capable of speeds above 25kn (29MPH)—Review the installation location and operating results of similar boats before proceeding.

- **Fin keel sailboat**—Mount to the side of the centerline and forward of the fin keel 300–600mm (1–2').
- **Full keel sailboat**—Locate amidships and away from the keel at the point of minimum deadrise angle.

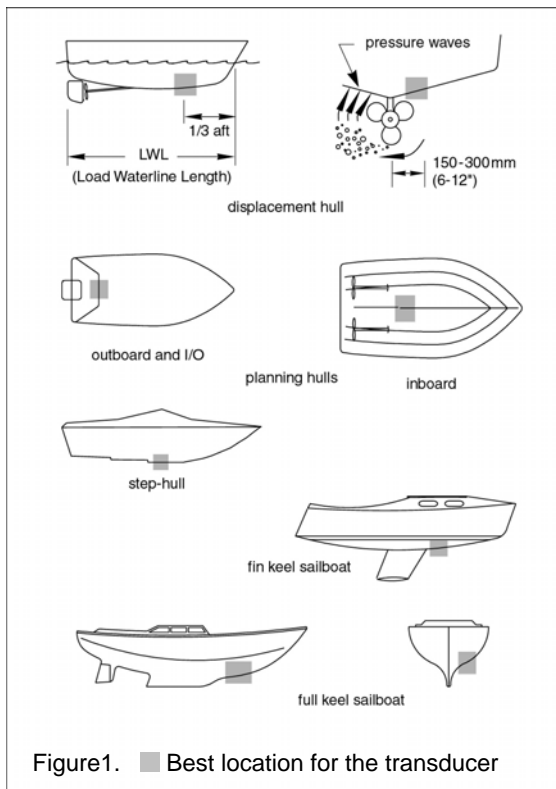

Figure1. ■ Best location for the transducer

4 Installation

Cored fiberglass hull—Follow separate instructions on page 4.

4.1 Hole Drilling

Warning: Always wear safety goggles and a dust mask.

1. Drill a 3 mm or 1/8" pilot hole from inside the hull. If there is a rib, strut, or other hull irregularity near the selected mounting location, drill from the outside.

Note: If the pilot hole is drilled in the wrong location, drill a second hole in a better location. Apply masking tape to the outside of the hull over the incorrect hole and fill it with epoxy.

2. Using the appropriate size hole saw, cut a hole from outside of the hull (see table on page 1).

Note: All flush models require a countersink tool to create a "seat" in the hull.

3. Sand and clean the area around the hole, inside and outside, to ensure that the sealant will adhere properly to the hull. If there is any petroleum residue inside the hull, remove it with either mild household detergent or a weak solvent (alcohol) before sanding.

Metal hull—Remove all burrs with a file and sandpaper.

4.2 Bedding

Caution: Never pull, carry, or hold the transducer by its cable; this may sever internal connections.

1. Remove the hull nut and any washer (see Figure 2). Also remove the cap nut and the transducer insert.
2. Apply a 2mm (1/16") thick layer of sealant around the lip of the housing that contacts the hull and up the sidewall of the housing, 6 mm (1/4") higher than the combined thickness of the hull, washer(s), and the hull nut. This will ensure there is sealant in the threads to seal the hull and to hold the hull nut securely in place.

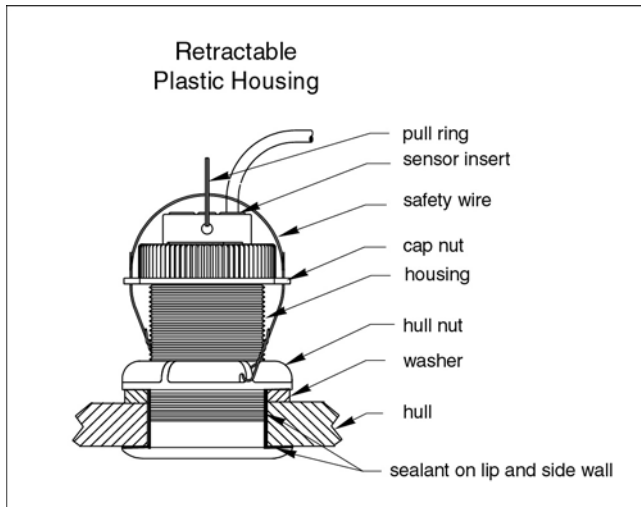

Figure 2

5 Installing

Note: Ignore any arrows on the housing, insert, and blanking plug.

1. From outside the hull, push the housing into the mounting hole using a twisting motion to squeeze out excess sealant (see Figure 2).
2. Slide the washer onto the housing inside the hull
Aluminum hull less than 6mm (1/4") thick—Use an additional washer. Never use bronze, since electrolytic corrosion will occur.
3. Screw the hull nut in place. Hand-tighten only. Do not over-tighten.
4. Remove the excess sealant on the outside of the hull to ensure smooth water flow over the transducer.
5. After the sealant cures, inspect and lubricate the O-rings on the insert with silicone grease or petroleum jelly. Slide the insert into the housing. Seat the insert into place with a twisting motion until the key fits into the notch. Be careful not to rotate the outer housing and disturb the sealant. Screw the cap nut in place and **hand-**

tighten only. *Do not* over tighten.

Warning: *Always attach the safety wire to prevent the insert from backing out in the unlikely event that the cap nut fails or is screwed on incorrectly.*

6. Attach the safety wire. Attach the safety wire to one eye in the hull nut. Lead the wire in a counterclockwise direction and thread it through one eye in the cap nut, the pull ring, the second eye in the cap nut, and the second eye in the hull nut. Twist the wire securely to itself.
7. Route the cable to the Server, being careful not to tear the cable jacket when passing it through the bulkhead(s) and other parts of the boat. To reduce electrical interference, separate the sensor cable from other electrical wiring and the engine. Coil any excess cable and secure it in place using zip-ties to prevent damage.
8. Refer to the Server manual to connect the sensor to the instrument.

5.1 Checking for Leaks

Caution: *Never install a thru-hull transducer and leave the boat in the water unchecked for several days.*

When the boat is placed in the water, **immediately** check around the thru-hull transducer for leaks. Note that very small leaks may not be readily observed. It is best not to leave the boat in the water for more than 3 hours before checking it again. If there is a small leak, there may be considerable bilge water accumulation after 24 hours. If a leak is observed, repeat "Bedding" and "Installing" *immediately*.

5.2 Blanking Plug

1. Inspect and lubricate the O-rings on the blanking plug with silicone grease or petroleum jelly.
2. Remove the safety wire from the pull ring and cap nut. Then, unscrew the cap nut (see Figure 2).
3. With the blanking plug ready in one hand, pull the insert most of the way out. Remove the insert and rapidly replace it with the plug. Seat it into place with a pushing twisting motion until the key fits into the notch in the housing. With practice, only 250ml (10oz.) of water will enter the boat. Screw the cap nut in place and *hand-tighten* only.

Warning: *Always attach the safety wire to prevent the insert from backing out in the unlikely event that the cap nut fails or is screwed on incorrectly.*

4. Reattach the safety wire.

5.3 Installation in a Cored Fiberglass Hull

The core (wood or foam) *must* be cut and sealed carefully. The core *must* be protected from water seepage, and the hull *must* be reinforced to prevent it from crushing under the hull nut allowing the housing to become loose.

Warning: *Always wear safety goggles and a dust mask.*

1. Drill a 3 mm or 1/8" pilot hole from inside the hull (see Figure 3). If there is a rib, strut, or other hull irregularity near the selected mounting location, drill from the outside. If the hole is drilled in the wrong location, drill a second hole in a better location. Apply masking tape to the outside of the hull over the incorrect hole and fill it with epoxy.
2. Using the appropriate size **outside hull** hole saw, cut a hole from outside the hull through the **outer** skin only (see table on page 1).
3. Using the appropriate size **inside hull** hole saw, cut through the **inner** skin and most of the core from inside the hull. The core material can be very soft. Apply only light pressure to the hole saw after cutting through the inner skin to avoid accidentally cutting the outer skin.
4. Remove the plug of core material, so the *inside* of the outer skin and the inner core of the hull is fully exposed. Sand and clean the inner skin, core, and the outer skin around the hole.

Caution: *Always completely seal the hull to prevent water seepage into the core.*

5. If you are skilled with fiberglass, saturate a layer of fiberglass cloth with a suitable resin and lay it inside the hole to seal and strengthen the core. Add layers until the hole is the correct diameter.
Alternatively, a hollow or solid cylinder of the correct diameter can be coated with wax and taped in place. Fill the gap between the cylinder and hull with casting epoxy. After the epoxy has set, remove the cylinder (see Figure 3).
6. Sand and clean the area around the hole, inside and outside, to ensure that the sealant will adhere properly to the hull. If there is any petroleum residue inside the hull, remove it with either mild household detergent or a weak solvent (alcohol) before sanding.
7. Proceed with "Bedding" and "Installing".

6 CONNECTION TO INSTRUMENT/CONTACTS

The depth transducer connects to the FI-30 Server or directly.

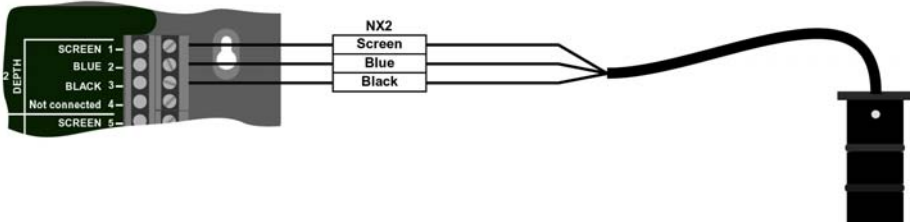

The transducer cable is clearly marked with No 2 and the colours will correspond to input screw terminal on the Server.

IMPORTANT! DO NOT CUT OR EXTEND THE 8 M TRANSDUCER CABLE!

7 Calibration

Calibration is carried out in the Multi Control instrument (see manual).

8 Maintenance

8.1 Antifouling Paint

Surfaces exposed to salt water *must* be coated with anti-fouling paint. Use **water-based** antifouling paint only. *Never* use ketone based antifouling paint, since ketones can attack many plastics possibly damaging the transducer. Apply antifouling paint every 6 months or at the beginning of each boating season.

8.2 Cleaning

Aquatic growth can accumulate rapidly on the transducer's surface, reducing its performance within weeks. Clean the surface with a soft cloth and mild household detergent. If the fouling is severe, use a stiff brush or putty knife to remove the growth taking care to avoid making scratches. Wet sanding is permissible with fine grade wet/dry paper.

9 TECHNICAL DATA

Dimensions Transducer:	51 x 86 mm (1 5/8" x 3 3/8")
Transducer cable:	8 m (9.9 ft + 26.2 ft)
Power supply:	12V DC (10-16V)
Power consumption:	0.2 W
Depth range:	0.8 - 150 m (3 - 450 ft) at speed up to 30 knots.
Accuracy:	± 0.1 %
Type of transducer:	Piezocrystal 200 kHz
Temperature range:	Operation -10°C to + 70°C Storage -35°C to +85°C

The depth measuring is based on the echos speed in water which is 1.463 m/sec.

DEPTH TH52

Copyright ©:
Nexus Marine AB
Kuskvägen 4, 191 62 Sollentuna, Sweden
Tel: +46 -(0) 8 – 506 939 00. Fax: +46 -(0) 8 -506 939 01
www.nexusmarine.se

22418-1 Edition 1

Free Manuals Download Website

<http://myh66.com>

<http://usermanuals.us>

<http://www.somanuals.com>

<http://www.4manuals.cc>

<http://www.manual-lib.com>

<http://www.404manual.com>

<http://www.luxmanual.com>

<http://aubethermostatmanual.com>

Golf course search by state

<http://golfingnear.com>

Email search by domain

<http://emailbydomain.com>

Auto manuals search

<http://auto.somanuals.com>

TV manuals search

<http://tv.somanuals.com>