



NILES®



INSTALLATION GUIDE



FOR USE IN MULTI-CHANNEL MUSIC OR HOME THEATER SYSTEMS
HIGH DEFINITION, LEFT/CENTER/RIGHT CHANNEL BOOKSHELF LOUDSPEAKER

HDLCR_{BX}

CONGRATULATIONS!

Thank you for choosing the **HDLCRbx High-Definition, Left/Center/Right Channel Loudspeaker** from Niles. With proper installation and operation, you should enjoy years of trouble-free use.

Niles manufactures the industry's most complete line of custom installation components and accessories for audio/video systems. To see the complete Niles product assortment, visit us on the Internet at: www.nilesaudio.com

TABLE OF CONTENTS

Introduction	1
Features and Benefits	1
Installation Considerations	3
Loudspeaker Placement	4
Finishing the Installation	7
Operation	10
Specifications	11
Limited Warranty	12
Warranty Registration Card	13

INTRODUCTION

The Niles HDLCRbx High-Definition, Left/Center/Right Channel Loudspeaker is expressly designed for superior sonic quality in front left-, center-, or front right-channel applications. It employs advanced technology components that extract the subtle nuances in recorded music or the thunderous action sound in a movie. The HDLCRbx is the perfect choice wherever quality of sound is the most important consideration.

FEATURES AND BENEFITS

DUAL 5-1/4-INCH TCC WOOFERS WITH BUTYL-RUBBER SUSPENSION

The HDLCRbx features newly-developed woofer-cone material that combines injection-molded polypropylene with talc, carbon, and ceramic (TCC) stiffening agents. As a result, the cone offers extreme stiffness and light weight for accurate, dynamic response. Additionally, the use of a butyl-rubber suspension offers substantial benefits, including increased movement without mechanical limitations, weather resistance, and improved midrange damping for better detail and clarity.

BUMPBACK™ WOOFER MAGNETS

Niles engineers have utilized a unique woofer magnet construction, allowing far greater “throw” or voice-coil excursion. The result is a new level of deep bass performance.

1-INCH TETERON TRI-LAMINATE TWEETER

The HDLCRbx's Teteron Tweeter employs a tri-laminate design consisting of an inner textile layer, which forms the dome, a high damping layer to kill unwanted resonances, and an outside layer of urethane to add stiffness and prevent breakup modes. The result is a transparently clear, sweet, natural-sounding tweeter, which still maintains extended frequency response.

D.S.F.G. DIRECTED SOUND FIELD GEOMETRY® DELIVERS OPTIMUM PHASE RESPONSE TO LISTENERS AND COMPENSATES FOR HIGH LOUDSPEAKER PLACEMENT

The HDLCRbx employs Niles' D.S.F.G. Directed Sound Field Geometry®. With D.S.F.G., the tweeter is offset from the center of the dual woofers. The resulting acoustic interaction between the woofers and the offset tweeter results in the flattest frequency and phase response, approximately 15-degrees off-axis from the tweeter. This gives optimum performance to a seated listener, even if the loudspeaker is mounted above or below a TV or screen.



ACOUSTIC FINE TUNING

The HDLCRbx includes acoustic fine-tuning controls on the rear panel. These controls enable optimization of the high frequencies and dialog with 3 dB of Treble Cut and 3 dB of Dialog Enhancement.

D.S.F.G. DIRECTED SOUND FIELD GEOMETRY® DEFEAT

The HDLCRbx includes a rear-panel control that enables the installer to deactivate the D.S.F.G. Directed Sound Field Geometry® in certain applications. For example, when the loudspeaker is installed at ear level behind a perforated screen, the loudspeaker's response can be improved with D.S.F.G. defeated.

NILES' HD HIGH-DEFINITION VOICE MATCHING

Ensures compatibility with other Niles HD High-Definition in-wall, on-wall, and ceiling-mount models to accommodate a wide range of system designs.

DOLBY® DIGITAL READY

The HDLCRbx is specifically designed for Home Theater Sound. This model exceeds the specifications set forth by Dolby Laboratories for the accurate reproduction of Dolby Digital-Encoded Sources.



INSTALLATION CONSIDERATIONS

RECOMMENDED AMPLIFIER POWER

For satisfactory performance, we recommend using a surround amplifier with a power rating of 10 to 150 watts. Curiously, most loudspeakers are not damaged by large amplifiers, but rather by small amplifiers. If your system is playing loud music, a small amplifier will run out of power very quickly and can create damaging “clipping” distortions. A more powerful amplifier will play at the same volume without distorting. See **OPERATION** on page 10 for more information about amplifier clipping distortion.

LOUDSPEAKER WIRE

Use 2-conductor loudspeaker wire when connecting loudspeakers to your receiver or amplifier. For most applications, we recommend using 16- or 18-gauge wire. For wiring runs longer than 80 feet, we recommend 14-gauge wire. The HDLCRbx’s gold-plated, five-way binding posts will accommodate up to 12-gauge wire directly. Larger sizes can be accommodated via pin connectors.

NOTE: THE HDLCRbx FEATURES GOLD-PLATED, FIVE-WAY BINDING POSTS THAT CAN BE CONNECTED IN SEVERAL DIFFERENT WAYS (E.G., BANANA PLUGS, SPADE TERMINALS, AND DIRECT WIRING).

When running wire inside walls or ceilings, use special jacketed cable (CL-2 or CL-3) to protect the wire and for fire prevention. In some areas, conduit is also required. For a trouble-free installation, low-voltage wire such as loudspeaker wire must be run in accordance with the National Electrical Code and any applicable provisions of the local building code. If you are unsure of the correct installation techniques, wire jacket, or type of conduit to use, consult a professional audio/video installer, building contractor, or the local building and inspection department.

TECH TIP

Wire size is expressed by its AWG (American Wire Gauge) number – the lower the number, the larger the wire. For example, 12 AWG is physically larger than 14 AWG.

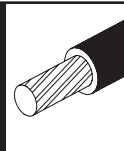

LOUDSPEAKER PLACEMENT

NOTE: THE NILES HDLCR_{BX} LOUDSPEAKER IS DESIGNED FOR USE IN FRONT LEFT-, CENTER-, OR FRONT RIGHT-CHANNEL APPLICATIONS ONLY. FOR BEST RESULTS, PLACE THE HDLCR_{BX} ON A STAND OR BOOKSHELF. FOR REAR-CHANNEL APPLICATIONS, WE RECOMMEND USING A NILES HDFX OR CM6HDF_X LOUDSPEAKER.

PLACING HDLCR_{BX}'S AS THE FRONT LEFT AND RIGHT LOUDSPEAKERS

In a home theater, the intelligibility of dialog and action reproduced by the front loudspeakers is paramount! The position of the loudspeakers plays a very important role in how clear the sound is and how a stereo image is created. Here are some guidelines to make the process of placement quick and easy:

- *Make sure the sound will not be blocked or reflected off furniture or other objects. The listener should have a direct line of sight with the front of the loudspeaker. To determine the best position, measure the "listening" distance between the ideal listening position (e.g., favorite chair or couch) and the wall in which you plan to install the loudspeakers.*
- *For stereo music applications, try to place the loudspeakers so that they are equally distant from the listening spot and at least one half of the listening distance apart to maintain a large pleasant stereo "image."*
- *In home theater applications where there is a center channel, you may choose to space the left and right main loudspeakers farther apart for a "bigger than life" sound with Dolby® encoded movies and TV shows. However, for combined music and movie usage, we recommend using the placement zone for stereo music. Ideally, if the listening position is 10 feet back from the wall, place the loudspeakers between 5 and 10 feet apart, as shown in **Figure 1**.*

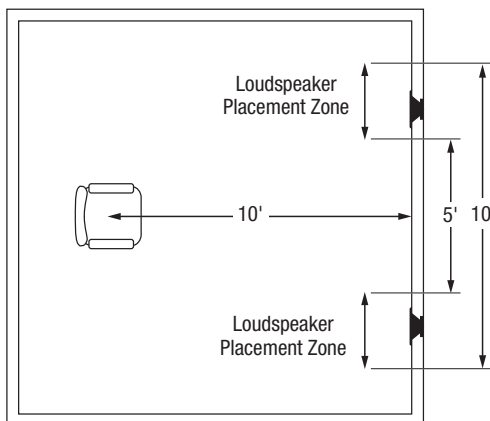

Figure 1. Recommended HDLCRbx loudspeaker placement for front left and right channels.

As for placement height, place front left and right loudspeakers vertically on either side of the picture source, so that their tweeters are not more than 24 inches above or below the center-channel loudspeaker's tweeter (see **Figure 2** on page 6). For best response, orient the loudspeakers so the tweeters face out.

NOTE: DO NOT PLACE AN HDLCR_{BX} LOUDSPEAKER TOO CLOSE TO A DIRECT-VIEW TV MONITOR, AS IT MAY CAUSE PICTURE DISCOLORATION. TEST THE PLACEMENT DISTANCE FOR PICTURE DEGRADATION BEFORE INSTALLATION.

THE BOUNDARY EFFECT

Placing a loudspeaker in a corner can powerfully affect the way a listener perceives bass response. Known as the boundary effect, placing loudspeakers close to a wall/ceiling boundary or near a corner-wall boundary will emphasize certain bass frequencies, while canceling others. This effect can make the loudspeaker sound excessively boomy and inaccurate to some listeners, while to others it just seems like more bass sound.

As a good rule-of-thumb, if you like listening to your current pair of loudspeakers with the bass turned up, you'll enjoy corner placement. However, if you listen with the tone controls at neutral, try keeping the loudspeakers at least 2 or 3 feet from the boundaries of the room.

PLACING AN HDLCR_{BX} AS THE CENTER-CHANNEL LOUDSPEAKER

The center-channel loudspeaker is the workhorse in a home theater system. It handles all of the critical dialog and is vitally important in creating the illusion of sounds emanating directly from the picture. Here are some tips for obtaining optimum center-channel performance:

- *In a typical installation, place the HDLCR_{BX} horizontally, directly above the television or projection screen. Try to insure that the loudspeaker is not placed too high relative to the left and right loudspeakers, as shown in **Figure 2** (on the next page).*

(CONTINUED ON NEXT PAGE)

PLACING AN HDLCR_{Bx} AS THE CENTER-CHANNEL LOUDSPEAKER (CONTINUED)

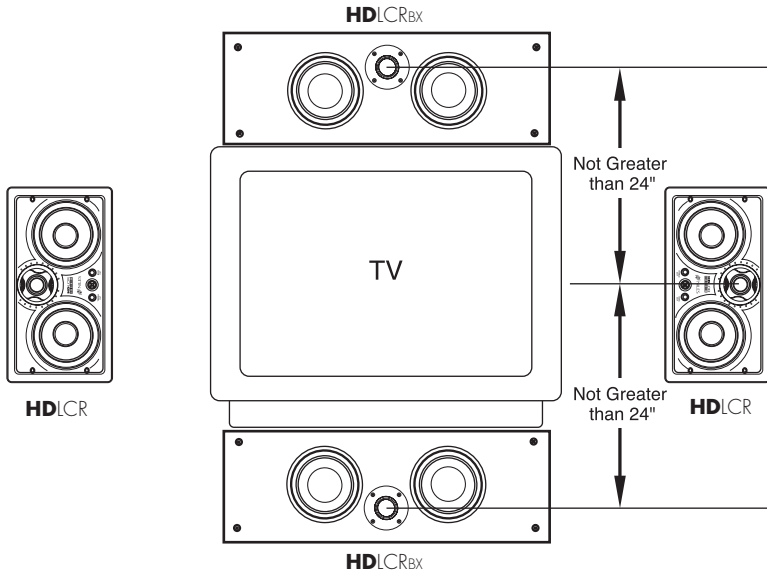

Figure 2. If the HDLCR_{Bx} is placed above a TV, orient the loudspeaker with the tweeter up. If it is placed below a TV, orient the HDLCR_{Bx} with the tweeter down.

- For installations where a perforated projection screen will be used, place the HDLCR_{Bx}, either horizontally or vertically, behind the screen at ear level, as shown in **Figure 3**.

NOTE: WHEN PLACING THE HDLCR_{Bx} AT EAR LEVEL, SET THE D.S.F.G. SWITCH (ON THE REAR) TO DEFEAT. SEE PAGE 7 FOR MORE DETAILS.

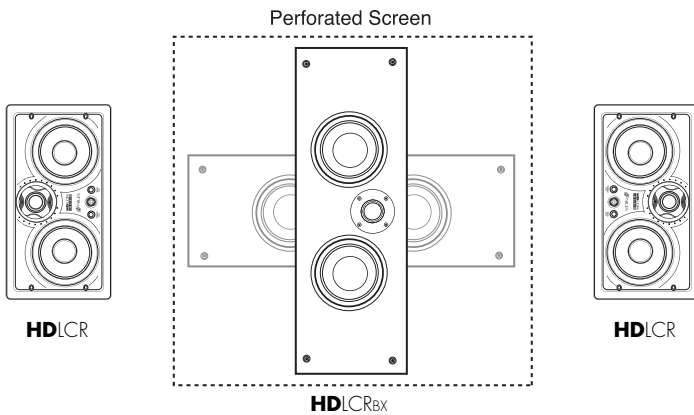

Figure 3. Recommended HDLCR_{Bx} center-channel placement behind a perforated projection screen.

FINISHING THE INSTALLATION

CONNECTING THE LOUDSPEAKER

1. *At each loudspeaker, separate the loudspeaker wire so that at least 2 inches of each conductor are free. Strip away 1/4 inch of insulation from each loudspeaker wire. Using correct polarity, connect the appropriate conductor to each five-way binding post.*

NOTE: Observe correct polarity: Positive (+) goes to the RED post and negative (–) goes to the BLACK post. If you are unsure of wire polarity, see the section, **Checking Loudspeaker Phase** on page 8.

2. *Connect the other end of the loudspeaker wires to the home theater receiver (or amplifier) in the same way.*
3. *Turn on the home theater receiver and calibrate all loudspeakers in the system according to the receiver manufacturer's instructions.*

CHECKING LOUDSPEAKER ORIENTATION FOR D.S.F.G. DIRECTED SOUND FIELD GEOMETRY®

The D.S.F.G. Directed Sound Field Geometry provides optimum off-axis phase and frequency response due to the acoustic interaction between the woofers and the tweeter. The flattest response will be obtained approximately 15 degrees off-axis in the direction opposite the tweeter. For optimum performance, refer to **Figure 4** (on the next page) and orient the loudspeaker as follows:

- *For center-channel use above a TV, place the HDLCRbx horizontally with the tweeter up. Set the D.S.F.G. switch to On.*
- *For center-channel use below a TV, place the HDLCRbx horizontally with the tweeter down. Set the D.S.F.G. switch to On.*
- *For front-channel use, place one HDLCRbx vertically on either side of the TV so the tweeters face outward. If the HDLCRbxs are at ear level, set both D.S.F.G. switches to Defeat. If the HDLCRbxs are above or below ear level, set both D.S.F.G. switches to On.*

ACOUSTIC FINE TUNING

Each HDLCRbx loudspeaker features separate Treble Cut and Dialog Enhance controls on the rear for acoustic fine-tuning after placement, as shown in **Figure 4**. Adjust these controls as follows:

- *Initially set Treble Cut to Flat and Dialog Enhance to Normal.*
- *If a HDLCRbx is placed in a room with highly reflective surfaces like glass or tile or the reproduced sound is too bright, set the Treble Cut switch to – 3 dB to lower the high-frequency response.*
- *Listen to dialog being reproduced on the HDLCRbx. If you want it more pronounced, set the Dialog Enhance switch to Enhance to boost the mid-frequency response.*

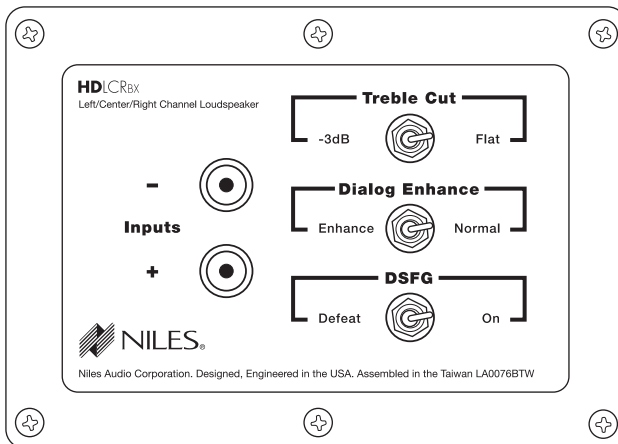



Figure 4. The HDLCRbx's Treble Cut, Dialog Enhance, and D.S.F.G. switches.

CHECKING LOUDSPEAKER PHASE

Loudspeaker wire has two conductors. On both your loudspeaker and amplifier, one conductor is attached to the negative (–) terminals, while the other is attached to the positive (+) terminals. Usually, the wire is marked for your convenience, but the marking can be done in the following different ways:

- *Stripe on one wire*
- *Ribbed area you can feel on one conductor*
- *Different colors of metal wire on each conductor*
- *Fabric strand or string wound into one of the conductors*



Of course, there are some wires that appear completely identical. So be careful, or you might make a connection mistake. If you do, one loudspeaker will be playing “out-of-phase” with the other loudspeaker. A pair of out-of-phase loudspeakers works against each other, and the sound of the two playing together will be lacking in bass and sound “phasey.” If you suspect the sound is not right, and you cannot see any markings on the wire, try this simple test:

1. *Stand halfway between the loudspeakers.*
2. *Play some music with the amplifier or receiver set to Mono.*
3. *Listen to the richness of the bass and the loudness of the sound.*
4. *Turn off the amplifier and reverse the connections on one amplifier channel only.*
5. *Repeat the listening test with the same volume control setting. When the sound has a richer bass and is slightly louder, the loudspeakers are working together or “in-phase.”*

INSTALLING THE GRILLE



If desired, at each loudspeaker, carefully fit the grille to its cabinet. Starting with one corner, gently press the grille frame around the loudspeaker’s edge, pushing it in at each of the four recessed holes. When properly installed, the grille will be absolutely flush in appearance with the cabinet.



OPERATION

LISTENING AT HIGHER VOLUMES

Achieving a reasonable volume of sound in a large room requires more amplifier power than it does in a small room. It is possible to turn the volume up so high that the amplifier runs out of power. This creates “clipping” distortion, which will make treble sound very harsh and unmusical.

When you hear harsh-sounding treble from any good loudspeaker, turn the volume down immediately! Those harsh sounds are masking much more powerful ultra-high-frequency sound spikes, which will quickly damage any fine loudspeaker. You are much less likely to damage a loudspeaker driven by a large amplifier because it will be very loud before any clipping distortion is produced.

CLEANING

To clean the enclosure, use a dampened soft cloth or paper towel. To clean the grille, use a gentle vacuum cleaner.

SPECIFICATIONS

Driver Complement

- Two 5-1/4" TCC Woofers
- 1" Teteron Tweeter with fluid cooling

Design Principle

- Acoustic suspension with a tuned port
- D.S.F.G. Directed Sound Field Geometry® for optimum phase and frequency response

Recommended Amplifier Power

10 to 150 watts per channel

Nominal Impedance

4 ohms

Frequency Response

45 Hz to 21 kHz, +/- 3 dB

Sensitivity

90 dB with 2.83 V pink noise input, measured at 1 meter on axis

Dimensions

21" L x 7-1/4" W x 9-3/4" D

Weight

21 lb

Wiring Requirements

We recommend using 16- to 18-gauge loudspeaker wire for runs up to 80 feet and 14-gauge loudspeaker wire for runs up to 200 feet. The connectors will accommodate 12- to 22-gauge wire.



LIMITED WARRANTY

NILES AUDIO CORPORATION (“NILES”) WARRANTS ITS LOUDSPEAKER PRODUCTS TO THE ORIGINAL PURCHASER TO BE FREE OF MANUFACTURING DEFECTS IN MATERIAL AND WORKMANSHIP FOR A PERIOD OF FIVE YEARS FROM DATE OF PURCHASE.

THIS WARRANTY IS SUBJECT TO THE FOLLOWING ADDITIONAL CONDITIONS AND LIMITATIONS. THE WARRANTY IS VOID AND INAPPLICABLE IF NILES DEEMS THAT THE PRODUCT HAS BEEN USED OR HANDLED OTHER THAN IN ACCORDANCE WITH THE INSTRUCTIONS PROVIDED BY THE MANUFACTURER, INCLUDING BUT NOT LIMITED TO DAMAGE CAUSED BY ACCIDENT, MISHANDLING, IMPROPER INSTALLATION, ABUSE, NEGLIGENCE, OR NORMAL WEAR AND TEAR, OR ANY DEFECT CAUSED BY REPAIR TO THE PRODUCT BY ANYONE OTHER THAN NILES OR AN AUTHORIZED NILES DEALER.

TO OBTAIN WARRANTY SERVICE, TAKE THE UNIT TO THE NEAREST AUTHORIZED NILES DEALER, WHO WILL TEST THE PRODUCT AND IF NECESSARY, FORWARD IT TO NILES FOR SERVICE. IF THERE ARE NO AUTHORIZED NILES DEALERS IN YOUR AREA, YOU MUST WRITE TO NILES AND INCLUDE YOUR NAME, ADDRESS, MODEL AND SERIAL NUMBER OF YOUR UNIT, ALONG WITH A BRIEF DESCRIPTION OF THE PROBLEM. A FACTORY RETURN AUTHORIZATION NUMBER WILL BE SENT TO YOU. DO NOT RETURN ANY UNIT WITHOUT FIRST RECEIVING WRITTEN AUTHORIZATION AND SHIPPING INSTRUCTIONS FROM NILES.

IF THE ABOVE CONDITIONS ARE MET, THE PURCHASER’S SOLE REMEDY SHALL BE TO RETURN THE PRODUCT TO NILES, IN WHICH CASE NILES WILL REPAIR OR REPLACE, AT ITS SOLE OPTION, THE DEFECTIVE PRODUCT WITHOUT CHARGE FOR PARTS OR LABOR. NILES WILL RETURN A UNIT REPAIRED OR REPLACED UNDER WARRANTY BY SHIPPING SAME BY ITS USUAL SHIPPING METHOD FROM THE FACTORY (ONLY) AT ITS EXPENSE WITHIN THE UNITED STATES OF AMERICA. THERE ARE NO OTHER WARRANTIES, INCLUDING WITHOUT LIMITATION, EITHER EXPRESS OR IMPLIED WARRANTIES OF MERCHANTABILITY OR FITNESS FOR A PARTICULAR PURPOSE, WITH RESPECT TO THE PRODUCT.

REPAIR OR REPLACEMENT AS PROVIDED UNDER THIS WARRANTY IS THE EXCLUSIVE REMEDY OF THE CONSUMER/PURCHASER. NILES SHALL NOT BE RESPONSIBLE FOR ANY INCIDENTAL OR CONSEQUENTIAL DAMAGES EXCEPT TO THE EXTENT PROVIDED (OR PROHIBITED) BY APPLICABLE LAW.

SOME STATES DO NOT ALLOW THE EXCLUSION OR LIMITATION OF INCIDENTAL OR CONSEQUENTIAL DAMAGES, SO THE ABOVE LIMITATION MAY NOT APPLY TO YOU. THIS WARRANTY GIVES YOU SPECIFIC LEGAL RIGHTS, AND YOU MAY ALSO HAVE OTHER RIGHTS WHICH VARY FROM STATE TO STATE.

FOR THE NAME OF YOUR NEAREST AUTHORIZED NILES DEALER CONTACT:
NILES AUDIO CORPORATION, P.O. BOX 160818, MIAMI, FLORIDA 33116-0818.

Please fill in your product information and retain for your records.

Model _____	Serial No. _____	Purchase Date _____
-------------	------------------	---------------------





WARRANTY REGISTRATION CARD

Model Purchased _____

Serial Number _____

Date Purchased (month/day/year) _____

Dealer Name and Location _____

Dr. Miss Mr. Mrs. Ms.

Name _____

Address _____

City _____ State _____ Zip _____

Telephone () _____

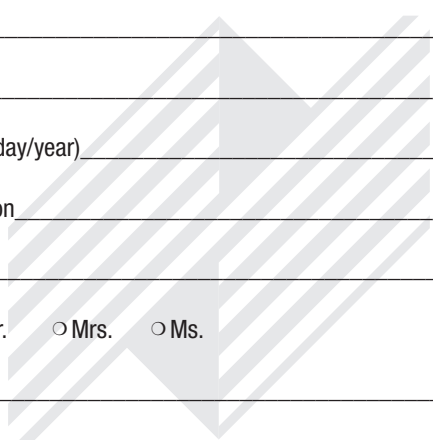

NILES®

Please take a moment to fill out our warranty registration card. The information helps us to get to know you better and develop the products you want

Age:

- Under 25
- 25-34
- 35-44
- 45-54
- 55 & over

Income:

- Under \$24,999
- \$25,000-\$34,999
- \$35,000-\$44,999
- \$45,000-\$59,999
- \$60,000-\$74,999
- \$75,000-\$99,999
- Over \$99,999

Occupation:

- Arts/Entertainment
- Business Owner
- Engineer
- Finance/Accounting
- General Office
- Management
- Professional
- Sales/Marketing
- Student
- Tradesperson

Musical tastes:

(Please check all that apply)

- Alternative
- Classical
- Country
- Jazz
- New Age
- Popular
- R&B
- Rock
- Other _____

How did you hear about Niles?

- Architect/Developer
- Custom Installer
- Direct Mail
- Friend/Family
- In-Store Display
- Interior Designer
- Magazine Ad
- Mail-Order Catalog
- Newspaper Ad
- Product Brochure
- Product Review
- Retail Salesperson

What magazines do you read?

1. _____
2. _____
3. _____

Who will install the product?

- Custom Installer
- Electrician
- Friend
- Myself

Which factor(s) influenced the purchase of your Niles product? (Please check all that apply)

- Ease of Use
- Price/Value
- Product Features
- Quality/Durability
- Reputation
- Style/Appearance
- Warranty

Do you . . . ?

Own a House. If yes, how many square feet?

- Own a Town House/Condominium/Co-op
- Rent an Apartment
- Rent a House

Are you interested in receiving literature on other Niles products?

- Yes No

Are there products/capabilities that you would like to see introduced?

DETACH HERE AND RETURN TO: NILES AUDIO CORPORATION WARRANTY REGISTRATION DEPT. P.O. BOX 160818 MIAMI, FLORIDA 33116-0818





BLENDING HIGH FIDELITY AND ARCHITECTURE®

Niles Audio Corporation
12331 S.W. 130 Street Miami, Florida 33186
Designed and Engineered in USA
Made in China

©2005 Niles Audio Corporation. All rights reserved. Niles, the Niles logos, Blending High Fidelity and Architecture and D.S.F.G. Directed Sound Field Geometry are registered trademarks of Niles Audio Corporation. All other trademarks are the property of their respective owners. Printed in China. 05/05 DS00420ACN

Free Manuals Download Website

<http://myh66.com>

<http://usermanuals.us>

<http://www.somanuals.com>

<http://www.4manuals.cc>

<http://www.manual-lib.com>

<http://www.404manual.com>

<http://www.luxmanual.com>

<http://aubethermostatmanual.com>

Golf course search by state

<http://golfingnear.com>

Email search by domain

<http://emailbydomain.com>

Auto manuals search

<http://auto.somanuals.com>

TV manuals search

<http://tv.somanuals.com>