

# **NordicTrack**<sup>®</sup> **ASR 630**

Model No. 831.23765.1

Serial No. \_\_\_\_\_

Write the serial number in the space above for reference.

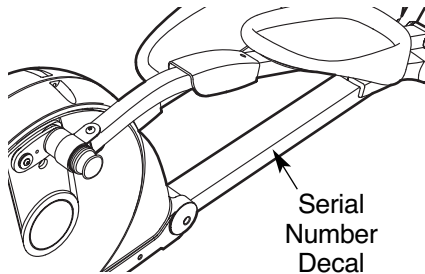

## USER'S MANUAL

### QUESTIONS?

As a manufacturer, we are committed to providing complete customer satisfaction. If you have questions, or if parts are damaged or missing, **PLEASE DO NOT CONTACT THE STORE; please contact Customer Care.**

**IMPORTANT:** You must note the product model number and serial number (see the drawing above) before contacting us:

CALL TOLL-FREE:

**1-888-825-2588**

Mon.–Fri. 6 a.m.–6 p.m. MST

Sat. 8 a.m.–4 p.m. MST

ON THE WEB:

[www.nordictrackservice.com](http://www.nordictrackservice.com)

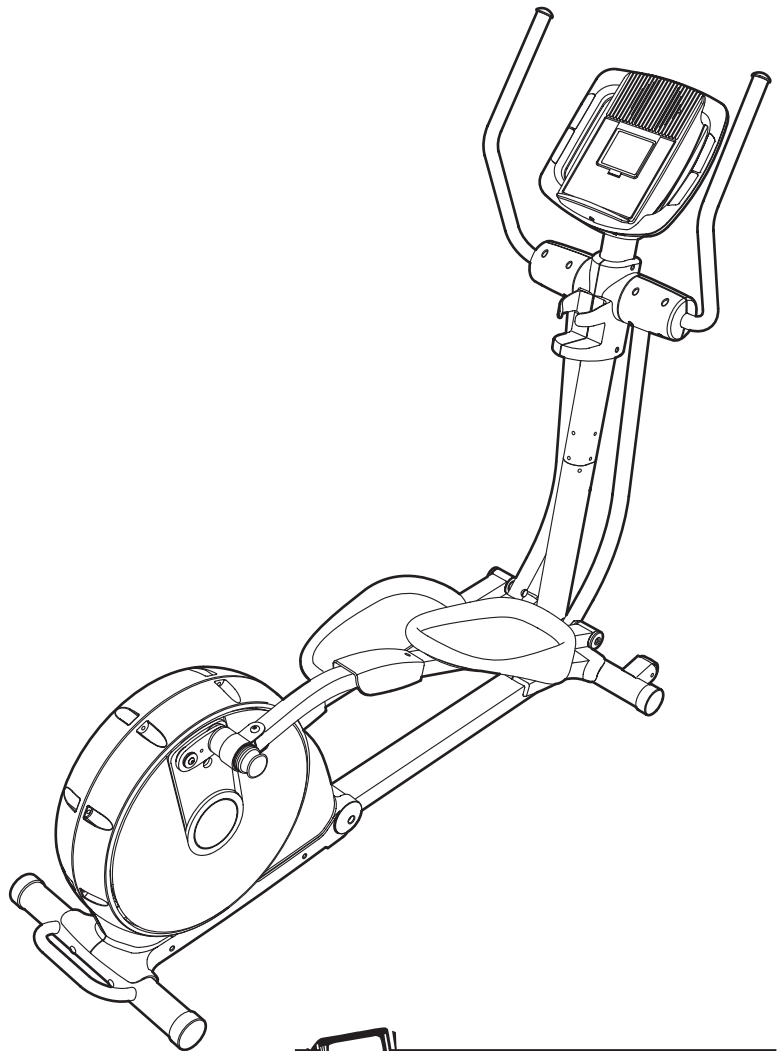

### CAUTION

Read all precautions and instructions in this manual before using this equipment. Keep this manual for future reference.



Visit our website at

[www.nordictrack.com](http://www.nordictrack.com)

new products, prizes,  
fitness tips, and much more!

# TABLE OF CONTENTS

WARNING DECAL PLACEMENT .....	.2
IMPORTANT PRECAUTIONS .....	.3
BEFORE YOU BEGIN .....	.4
ASSEMBLY .....	.5
HOW TO USE THE ELLIPTICAL EXERCISER .....	.12
MAINTENANCE AND TROUBLESHOOTING .....	.20
EXERCISE GUIDELINES .....	.21
PART LIST .....	.24
EXPLODED DRAWING .....	.26
ORDERING REPLACEMENT PARTS .....	.Back Cover
LIMITED WARRANTY .....	.Back Cover

## WARNING DECAL PLACEMENT

The warning decals shown here have been applied in the locations shown. **If a decal is missing or illegible, call the telephone number on the front cover of this manual and request a free replacement decal. Apply the decal in the location shown.** Note: The decals may not be shown at actual size.

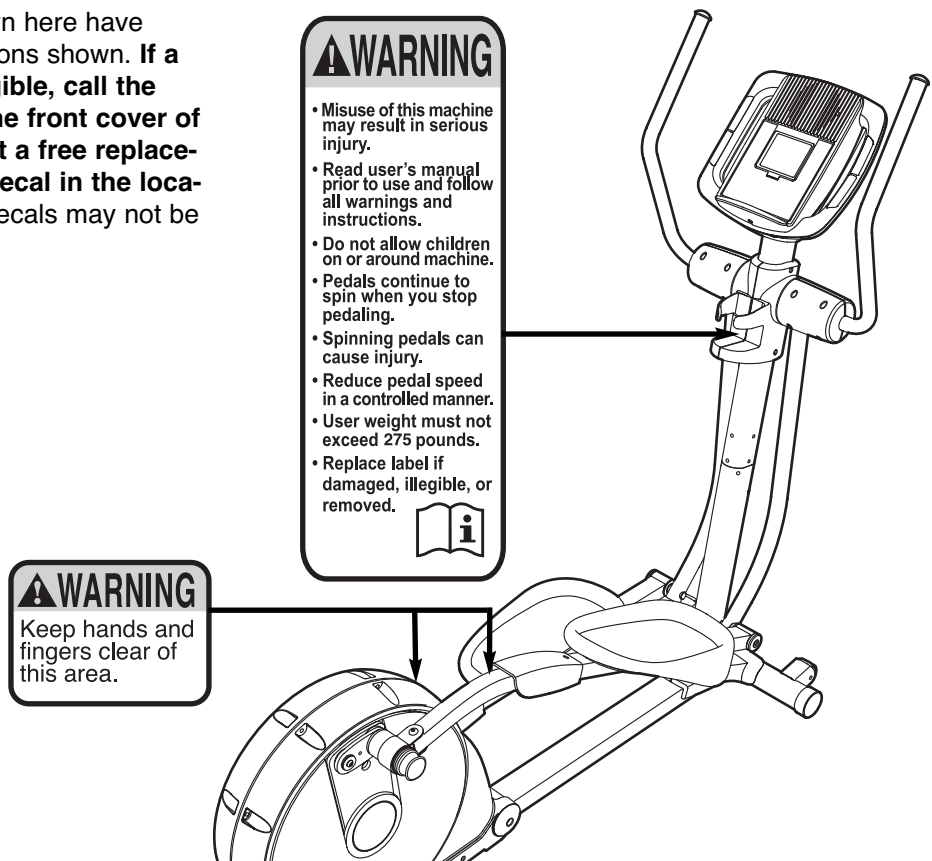

# IMPORTANT PRECAUTIONS

**⚠ WARNING:** To reduce the risk of serious injury, read all important precautions and instructions in this manual and all warnings on your elliptical exerciser before using your elliptical exerciser. ICON assumes no responsibility for personal injury or property damage sustained by or through the use of this product.

1. Before beginning any exercise program, consult your physician. This is especially important for persons over the age of 35 or persons with pre-existing health problems.
2. It is the responsibility of the owner to ensure that all users of the elliptical exerciser are adequately informed of all precautions.
3. Your elliptical exerciser is intended for home use only. Do not use your elliptical exerciser in a commercial, rental, or institutional setting.
4. Keep your elliptical exerciser indoors, away from moisture and dust. Place your elliptical exerciser on a level surface, with a mat beneath it to protect the floor or carpet. Make sure that there is enough clearance around your elliptical exerciser to mount, dismount, and use it.
5. Inspect and properly tighten all parts regularly. Replace any worn parts immediately.
6. Keep children under age 12 and pets away from your elliptical exerciser at all times.
7. Your elliptical exerciser should not be used by persons weighing more than 275 lbs. (124 kg).
8. Wear appropriate exercise clothes when exercising; do not wear loose clothes that could become caught on your elliptical exerciser. Always wear athletic shoes for foot protection.
9. Hold the handgrip pulse sensor or the upper body arms when mounting, dismounting, or using your elliptical exerciser.
10. Keep your back straight while using your elliptical exerciser; do not arch your back.
11. The pulse sensor is not a medical device. Various factors, including the user's movement, may affect the accuracy of heart rate readings. The pulse sensor is intended only as an exercise aid in determining heart rate trends in general.
12. When you stop exercising, allow the pedals to slowly come to a stop.
13. If you feel pain or dizziness while exercising, stop immediately and cool down.
14. Use your elliptical exerciser only as described in this manual.

# BEFORE YOU BEGIN

Thank you for purchasing the revolutionary NordicTrack® ASR 630 elliptical exerciser. The ASR 630 elliptical exerciser provides a wide array of features designed to make your workouts at home more effective and enjoyable—and when you're not exercising, the unique elliptical exerciser can be folded out of the way.

**For your benefit, read this manual carefully before you use the elliptical exerciser.** If you have ques-

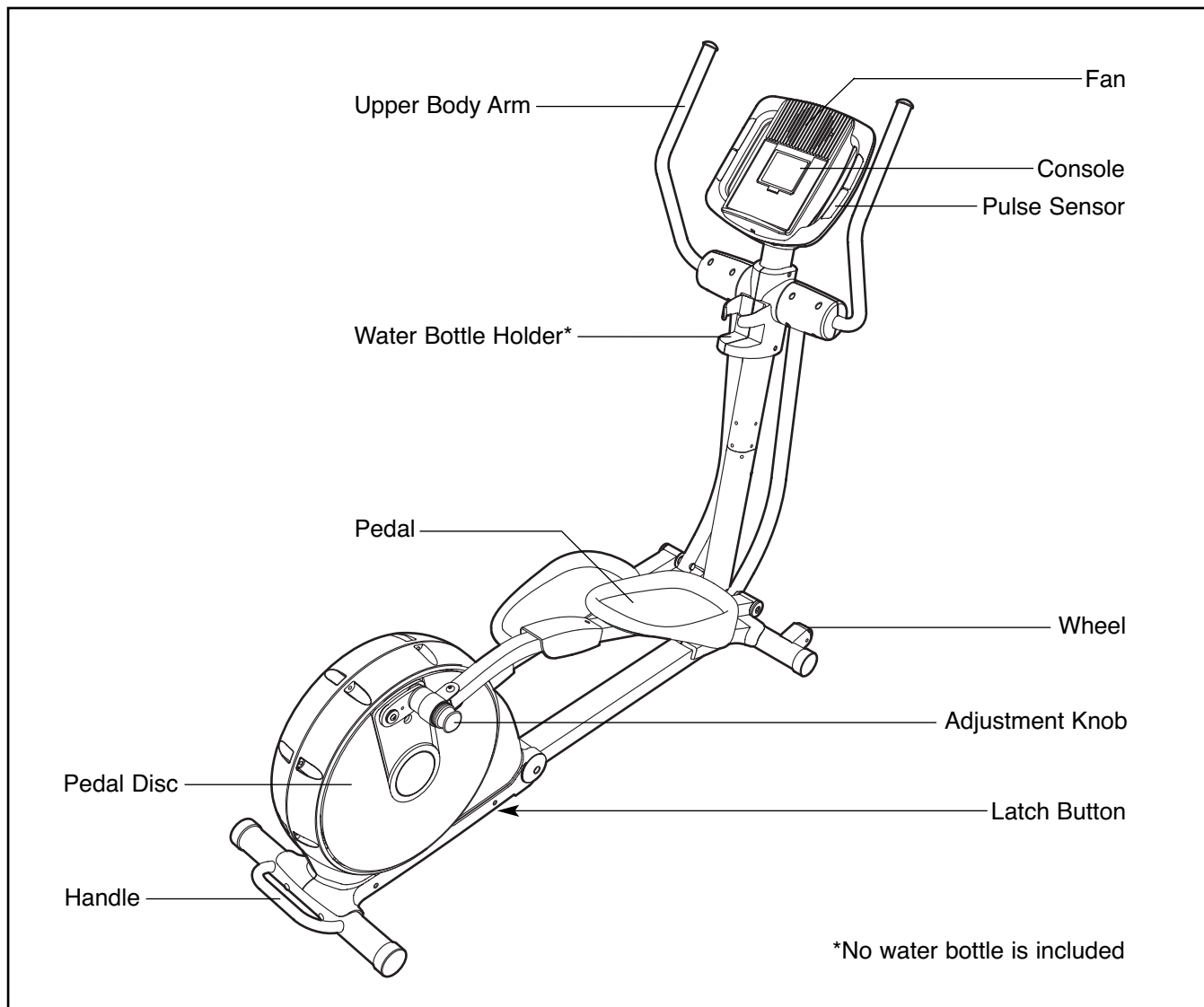

tions after reading this manual, please see the front cover of this manual. To help us assist you, note the product model number and serial number before contacting us. The model number and the location of the serial number decal are shown on the front cover of this manual.

Before reading further, please familiarize yourself with the parts that are labeled in the drawing below.

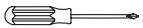

# ASSEMBLY

**Assembly requires two persons.** Place all parts of the elliptical exerciser in a cleared area and remove the packing materials. Do not dispose of the packing materials until assembly is completed.

**Assembly requires the included hex keys and your own Phillips screwdriver , adjustable wrench , and rubber mallet .**

As you assemble the elliptical exerciser, use the drawings below to identify small parts. The number in parentheses below each drawing is the key number of the part, from the PART LIST near the end of this manual. The number following the parentheses is the quantity needed for assembly. **Note: Some small parts may have been pre-assembled. If a part is not in the hardware kit, check to see if it has been preassembled.**

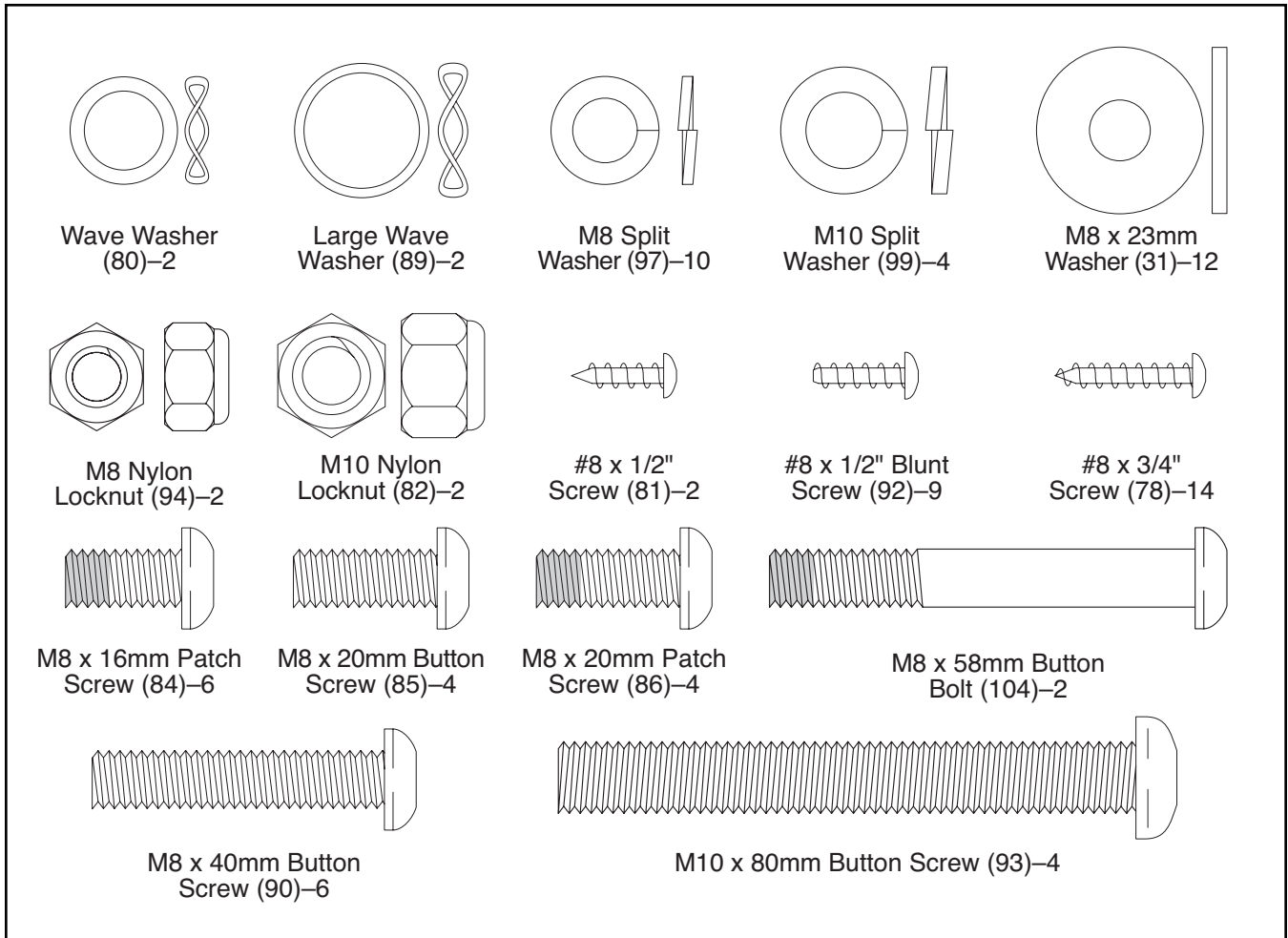

1. **To make assembly easier, read the information on page 5 before you begin assembling the elliptical exerciser.**

See **HOW TO FOLD AND UNFOLD THE ELLIPTICAL EXERCISER** on page 12 and unfold the elliptical exerciser.

While another person lifts the front of the Frame (1), attach the Front Stabilizer (4) to the Frame with two M10 x 80mm Button Screws (93), two M10 Split Washers (99), and two M10 Nylon Locknuts (82).

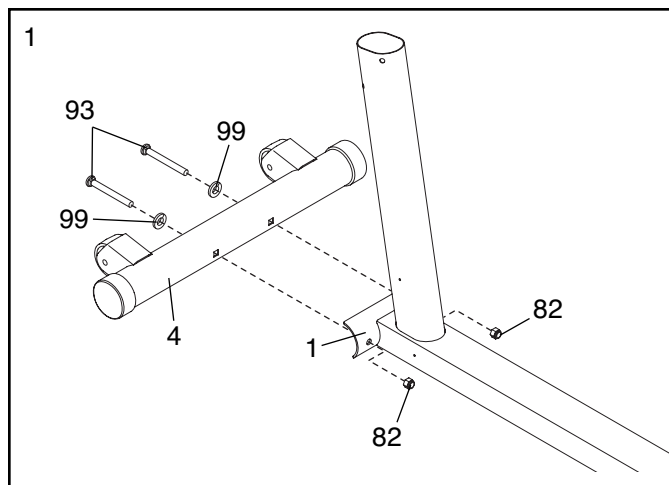

2. Attach the Left and Right Frame Covers (36, 37) around the Frame (1) with four #8 x 1/2" Blunt Screws (92).

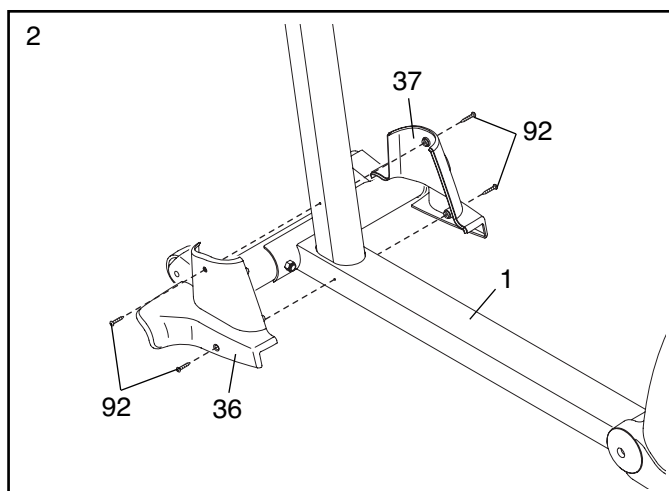

3. With the help of another person, carefully tip the elliptical exerciser onto its side. Attach the Center Foot (40) to the Frame (1) with two #8 x 1/2" Screws (81). Then, return the elliptical exerciser to the upright position.

Orient the Rear Stabilizer (3) as shown. While another person lifts the Folding Frame (2), attach the Rear Stabilizer to the Folding Frame with two M10 x 80mm Button Screws (93) and two M10 Washers (99).

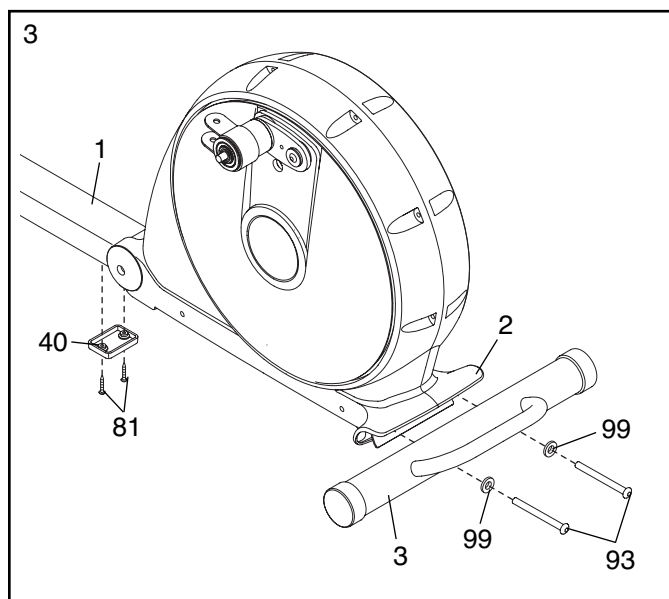

4. While another person holds the Upright (10) near the Frame (1), connect the Upper Wire Harness (65) to the Lower Wire Harness (64).

Then, insert the Upright (10) into the Frame (1). Attach the Upright with four M8 x 20mm Button Screws (85) and four M8 Split Washers (97). **Do not tighten the Button Screws yet.**

**Avoid pinching the Wire Harnesses (64, 65) during this step.**

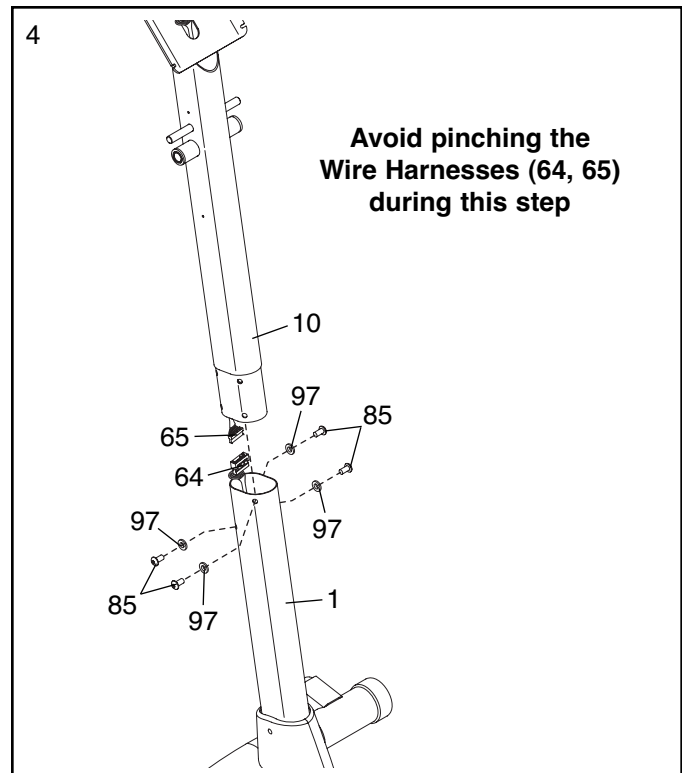

5. Orient the Left and Right Upright Covers (19, 20) as shown. Attach the Upright Covers around the Upright (10) with five #8 x 1/2" Blunt Screws (92).

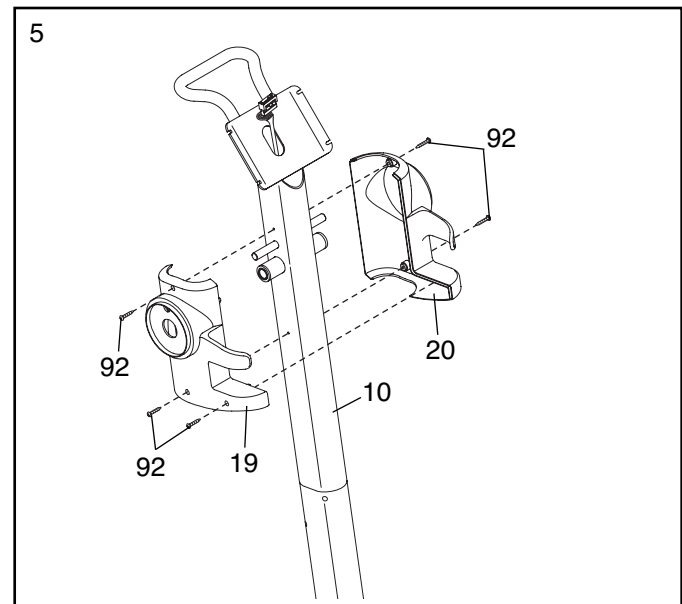

6. Apply a generous amount of the included grease to the Upper Body Axle (71). Insert the Upper Body Axle into the Upright (10). **Be careful not to damage the Upper Wire Harness (65).**

Apply a small amount of grease to a Wave Washer (80). Slide the Wave Washer onto the left end of the Upper Body Axle (71).

Identify the Left Upper Body Leg (24), which is marked with a sticker, and orient it as shown. Slide the Left Upper Body Leg onto the left side of the Upper Body Axle (71).

Attach the Left Upper Body Leg (24) to the Upper Body Axle (71) with an M8 x 20mm Patch Screw (86) and an M8 x 23mm Washer (31).

**Repeat this step for the Right Upper Body Leg (72).**

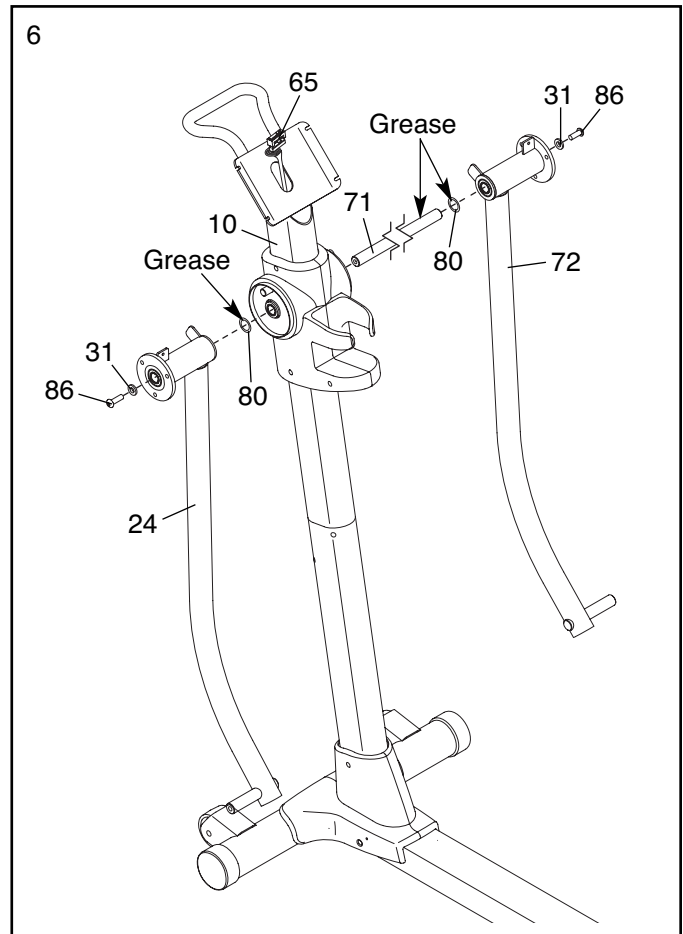

7. Attach the Left Upper Body Arm (22) to the Left Upper Body Leg (24) with three M8 x 16mm Patch Screws (84) and three M8 x 23mm Washers (31); **start all three Patch Screws and then tighten them.**

**Attach the Right Upper Body Arm (23) in the same way.**

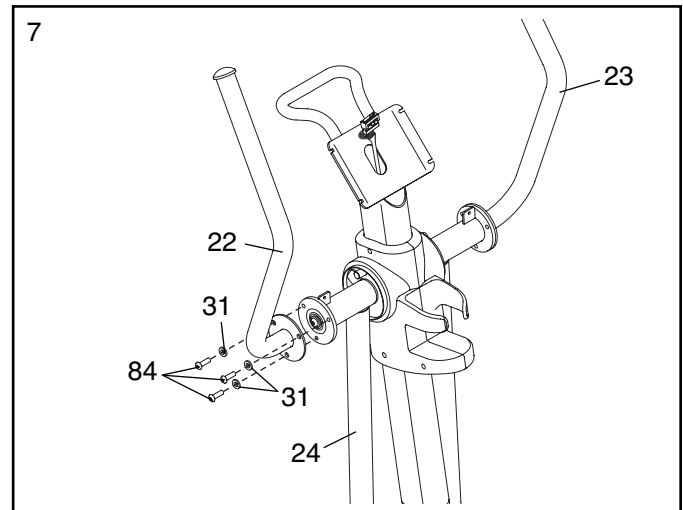



8. Have another person hold the Left Rear Upper Body Cover (26) and the Left Front Upper Body Cover (27) around the Left Upper Body Leg (24).

Attach the Left Rear Upper Body Cover (26) with a #8 x 3/4" Screw (78). Then, attach the Left Front Upper Body Cover (27) with four #8 x 3/4" Screws (78).

**Attach the Right Rear Upper Body Cover (28) and the Right Front Upper Body Cover (29) in the same way.**

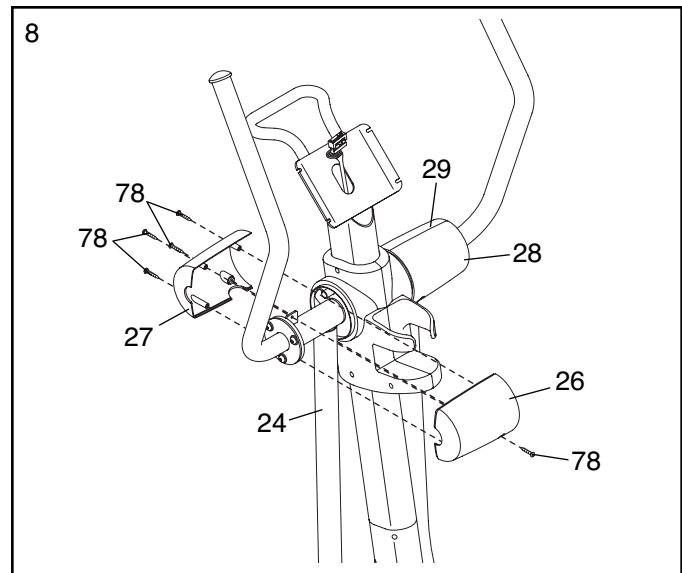

9. The Console (11) can be operated with four 1.5V "D" batteries (not included); alkaline batteries are recommended. **IMPORTANT: If the elliptical exerciser has been exposed to cold temperatures, allow it to warm to room temperature before inserting batteries into the Console. If you do not do this, the console displays or other electronic components may become damaged.** Remove the battery cover and insert four batteries into the Console. Make sure that the batteries are oriented as shown at the right. Then, reattach the battery cover.

The Console (11) can also be operated with a regulated 6-volt DC 2-amp power supply (not included). **To purchase a power supply, call your local Sears store. To avoid damaging the console, use only a manufacturer-supplied power supply.** Plug one end of the power supply into the jack on the Console; plug the other end into an outlet installed in accordance with all local codes and ordinances.

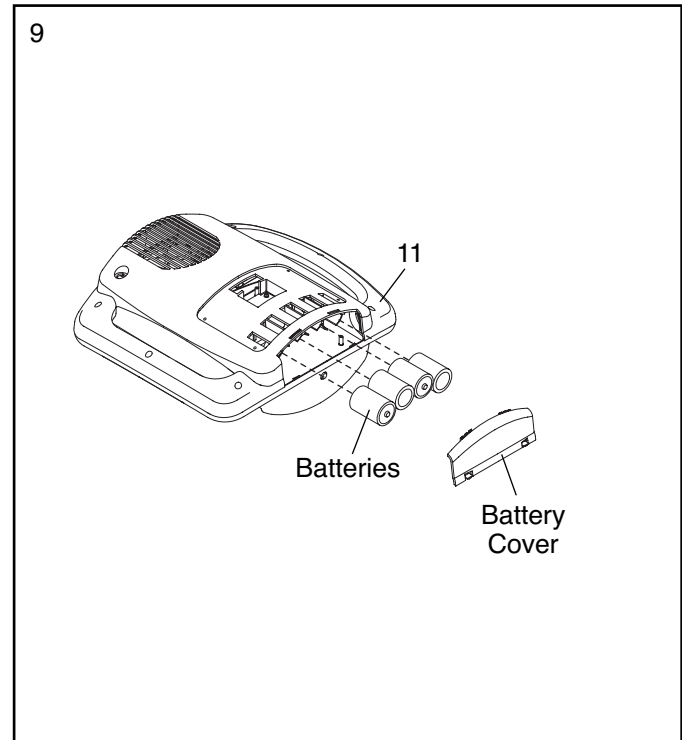

10. While another person holds the Console (11) near the Upright (10), connect the console wire harness to the Upper Wire Harness (65).

Attach the Console (11) to the Upright (10) with four #8 x 3/4" Screws (78); **start all four Screws and then tighten them. Avoid pinching the wire harnesses during this step.**

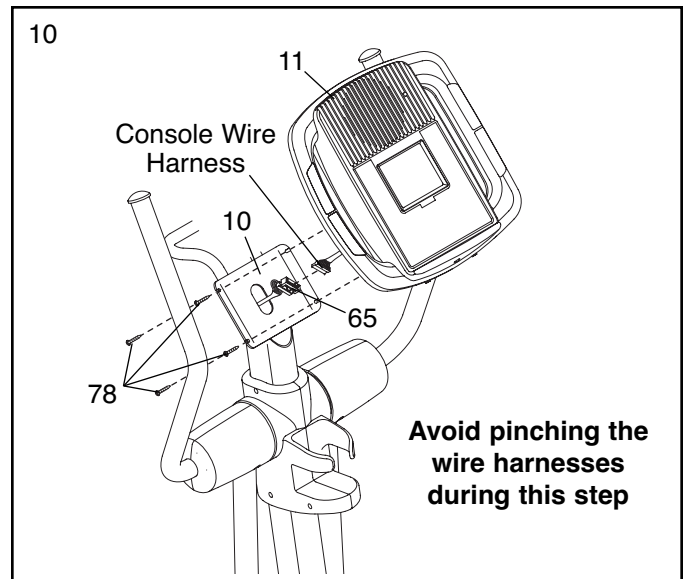

11. Orient a Pedal Arm (32) as shown. Attach the Left Pedal (34) to the Pedal Arm with three M8 x 40mm Button Screws (90) and three M8 Split Washers (97).

**Repeat this step for the Right Pedal (not shown) and the other Pedal Arm (not shown).**

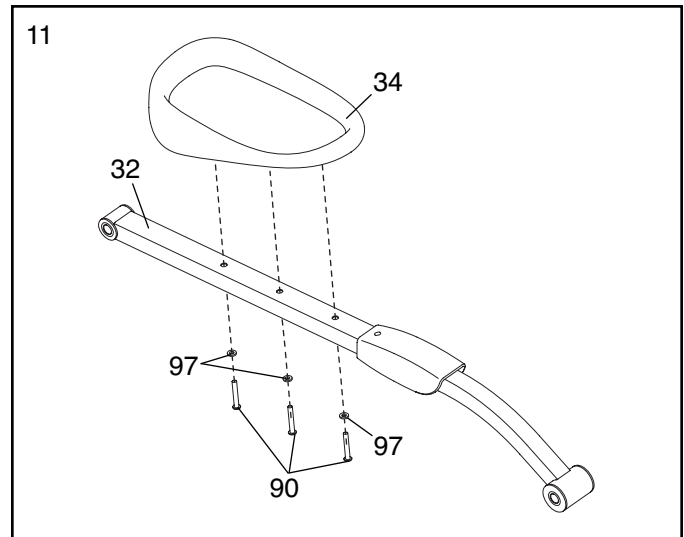

12. Apply a generous amount of grease to the axle on the Left Upper Body Leg (24). Then, apply grease to a Large Wave Washer (89).

Slide an Upper Body Leg Spacer (9) and a Large Wave Washer (89) onto the Left Upper Body Leg (24). **Make sure that the flat side of the Upper Body Leg Spacer is facing outward.**

At the same time, slide the left Pedal Arm (32) onto the Left Upper Body Leg (24) and insert the left Link Arm (30) into the left Link Arm Bracket (107).

Apply a small amount of grease to an M10 x 58mm Patch Bolt (104) and to the left Link Arm Bracket (107). Attach the Link Arm (30) to the Link Arm Bracket with the Patch Bolt, an M8 x 23mm Washer (31) and an M8 Nylon Locknut (94).

Then, attach the Pedal Arm (32) to the Left Upper Body Leg (24) with an M8 x 20mm Patch Screw (86), an Axle Cover (66), and an M8 x 23mm Washer (31).

**Repeat this step for the right Pedal Arm (32) and the right Link Arm (30).**

**See step 4. Tighten the M8 x 20mm Button Screws (85).**

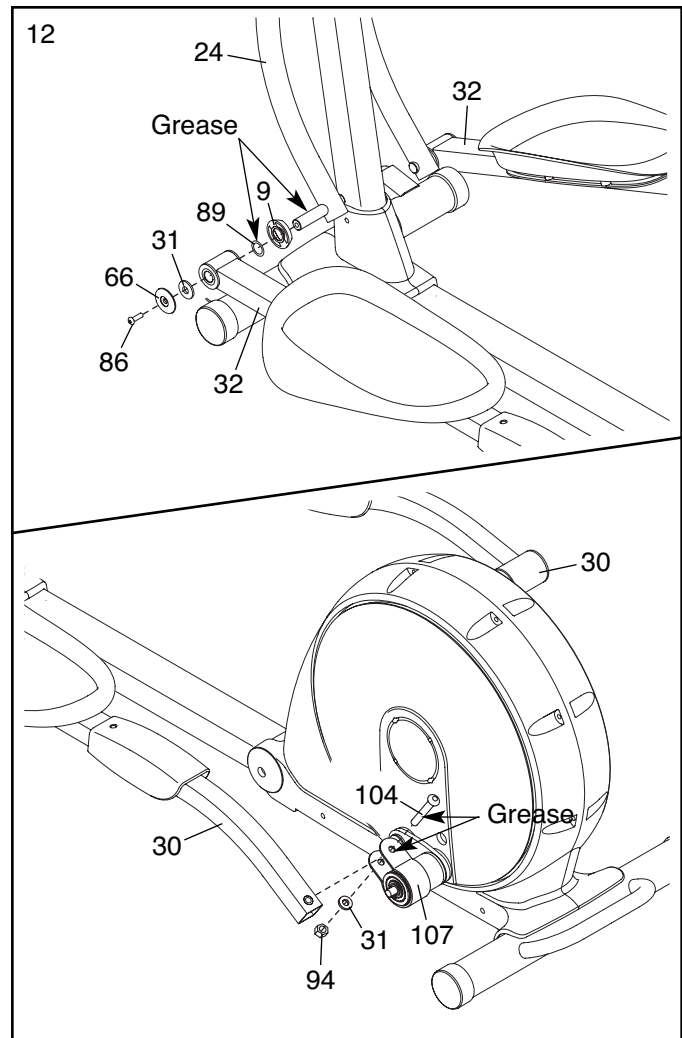

13. Tighten an Adjustment Knob (52) onto an Adjustment Pin (101).

**Repeat this step for the other Adjustment Knob (not shown) and the other Adjustment Pin (not shown).**

Note: See HOW TO ADJUST THE STRIDE OF THE ELLIPTICAL EXERCISER on page 13 and make sure that the right and left sides of the elliptical exerciser are adjusted to the same stride length.

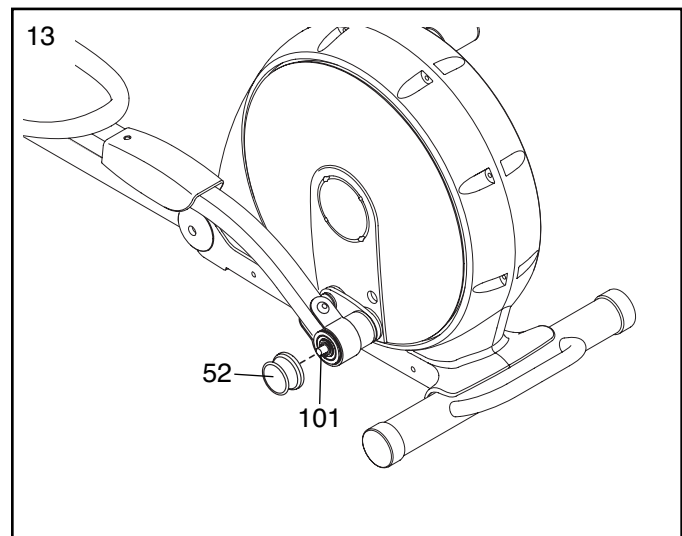

14. **Make sure that all parts of the elliptical exerciser are properly tightened.** Note: Some hardware may be left over after assembly is completed. To protect the floor or carpet from damage, place a mat under the elliptical exerciser.

# HOW TO USE THE ELLIPTICAL EXERCISER

## HOW TO FOLD AND UNFOLD THE ELLIPTICAL EXERCISER

When the elliptical exerciser is not in use, the frame can be folded out of the way. To fold the elliptical exerciser, lift the handle on the rear of the elliptical exerciser until the elliptical exerciser locks into the vertical position.

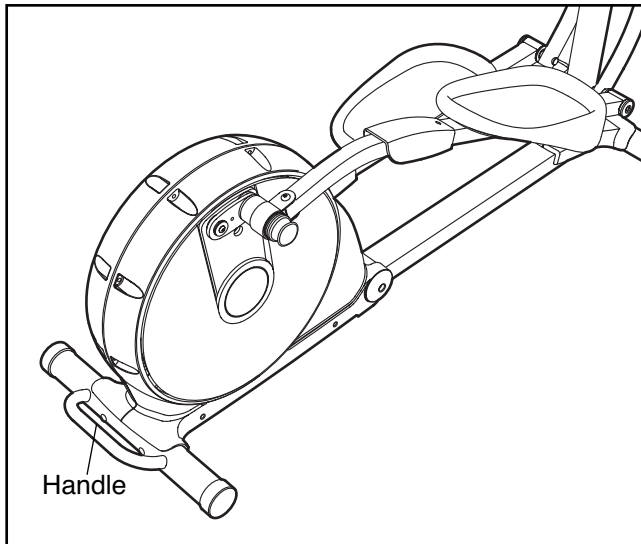

To unfold the elliptical exerciser, hold the handle, press the latch button, and then lower the frame to the floor.

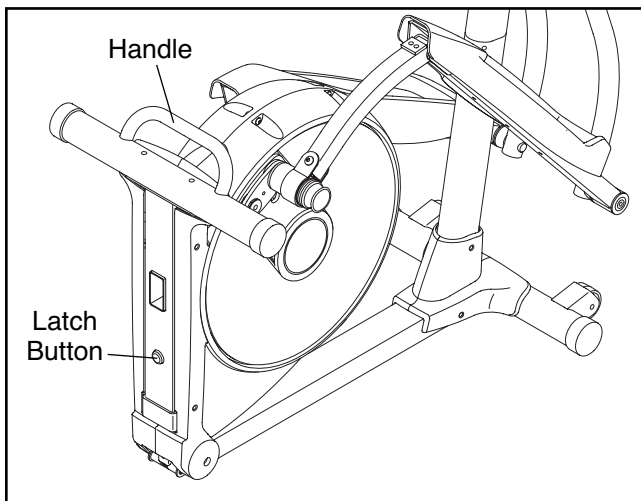

## HOW TO MOVE THE ELLIPTICAL EXERCISER

To move the elliptical exerciser, first fold it as described at the left. Next, stand in front of the elliptical exerciser and place one foot against the center of the front stabilizer. Pull the transport handle backward until the elliptical exerciser will roll on the front wheels. Carefully move the elliptical exerciser to the desired position, and then lower it.

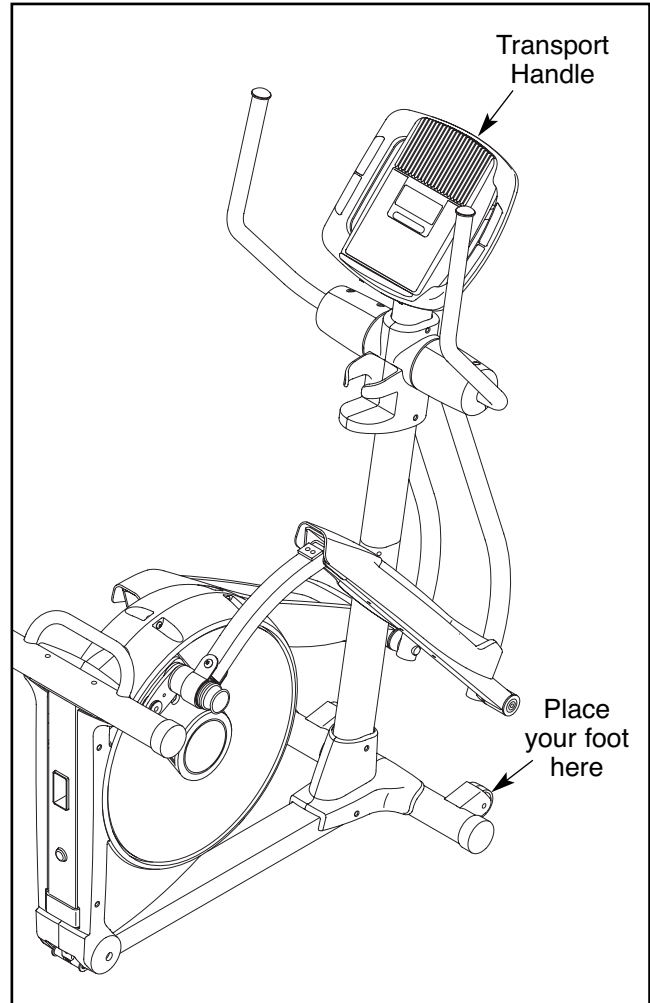

## HOW TO EXERCISE ON THE ELLIPTICAL EXERCISER

To mount the elliptical exerciser, hold the upper body arms and step onto the pedal that is in the lowest position. Next, step onto the other pedal. Push the pedals until they begin to move with a continuous motion.

**Note: The crank arms can turn in either direction. It is recommended that you turn the crank arms in the direction shown by the arrow below; however, for variety you can turn the crank arms in the opposite direction.**

To dismount the elliptical exerciser, wait until the pedals come to a complete stop. **Note: The elliptical exerciser does not have a free wheel; the pedals will continue to move until the flywheel stops.** When the pedals are stationary, step off the higher pedal first. Then, step off the lower pedal.

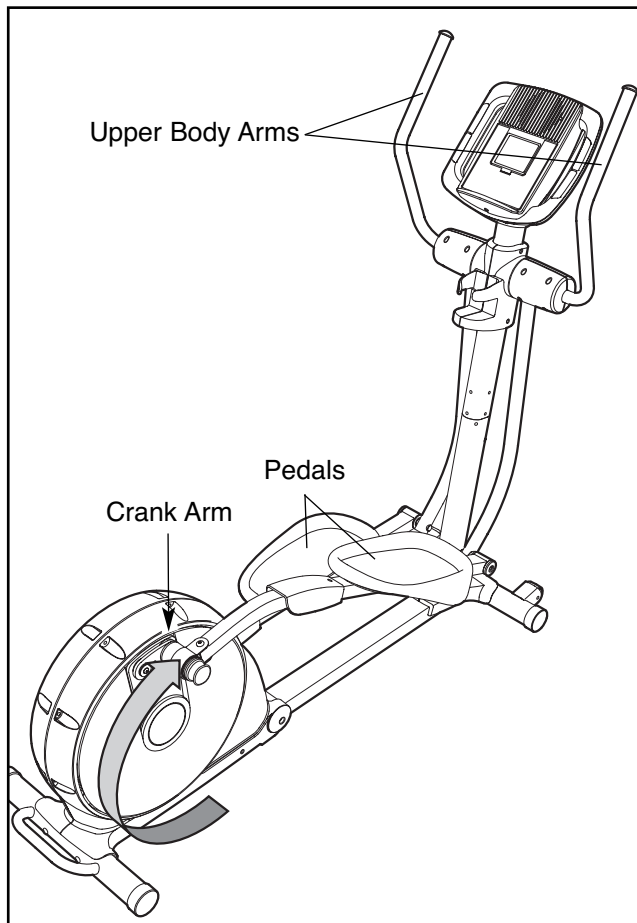

## HOW TO ADJUST THE STRIDE OF THE ELLIPTICAL EXERCISER

To adjust the stride of the elliptical exerciser, first pull one of the adjustment knobs until the adjustment bracket pivots freely. Pivot the adjustment bracket until the adjustment knob is aligned with one of the holes in the crank arm, and gently release the knob. Then, pivot the adjustment bracket back and forth slightly to make sure that the adjustment pin is engaged in one of the holes in the crank arm.

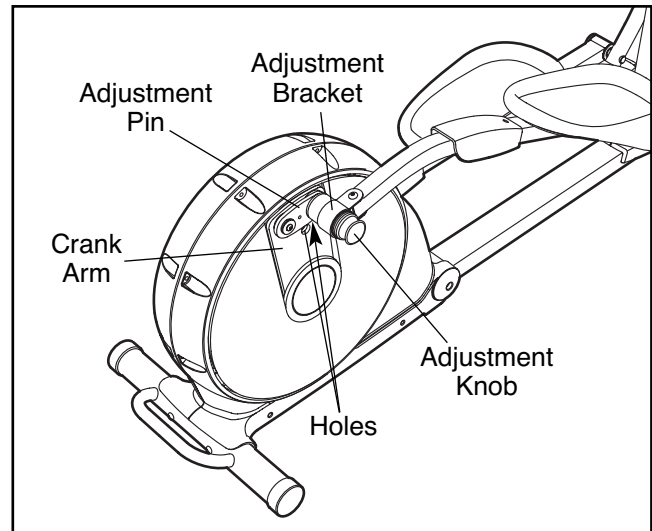

Adjust the other side of the elliptical exerciser in the same way; **make sure that each side of the elliptical exerciser is adjusted to the same stride length.**

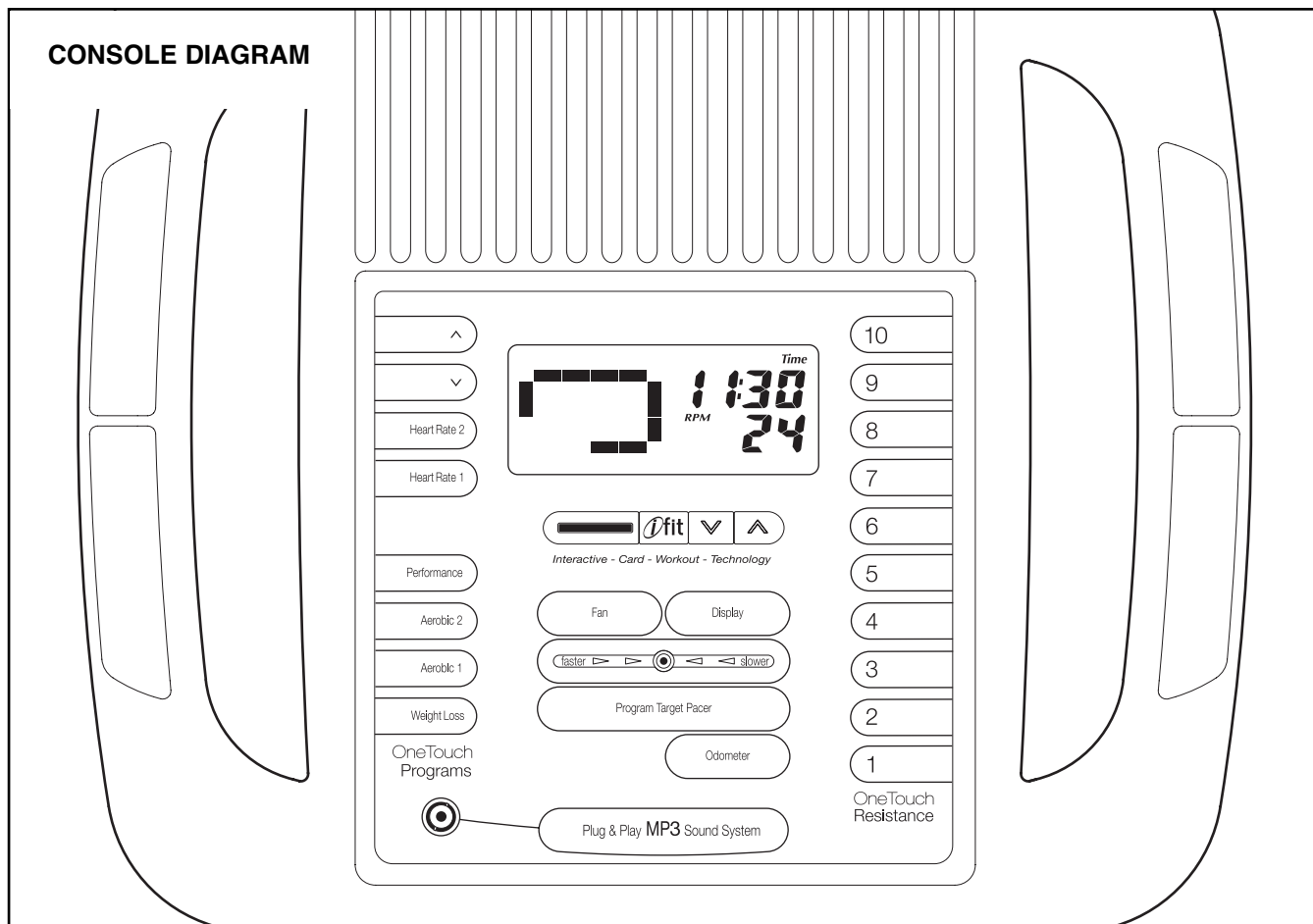

## CONSOLE DIAGRAM

### FEATURES OF THE CONSOLE

The advanced console offers an array of features designed to make your workouts more effective and enjoyable. When you select the manual mode of the console, you can change the resistance of the pedals with the touch of a button. As you exercise, the console will provide continuous exercise feedback. You can even measure your heart rate using the handgrip pulse sensor.

The console also offers four preset programs. Each program automatically changes the resistance of the pedals and prompts you to increase or decrease your pedaling pace as it guides you through an effective workout.

In addition, the console features two heart rate programs that change the resistance of the pedals to keep your heart rate near the target heart rate settings while you exercise.

The console also features the new iFIT Interactive Workout System. The iFIT Interactive Workout System is compatible with iFIT cards containing workout programs designed to help you achieve specific fitness goals. For example, lose unwanted pounds with the 8-week Weight Loss program. iFIT programs control the resistance of the pedals while the voice of a personal trainer coaches you and motivates you through your workouts. One demo iFIT card is included. Additional iFIT cards are available separately. **To purchase iFIT cards, go to [www.iFIT.com](http://www.iFIT.com) or call the telephone number on the front cover of this manual. iFIT cards are also available at select stores.**

You can even connect your MP3 player or CD player to the console's stereo sound system and listen to your favorite music or audio books while you exercise.

**To use the manual mode of the console**, follow the steps beginning on page 15. **To use a preset program**, see page 17. **To use a heart rate program**, see page 18. **To use an iFIT program**, see page 19. **To use the stereo sound system**, see page 19.

## HOW TO USE THE MANUAL MODE

Note: If there is a sheet of clear plastic on the face of the console, remove the plastic.

### 1. Press any button on the console or begin pedaling to turn on the console.

When you turn on the console, the display and the program target pacer will light. A tone will then sound and the console will be ready for use.

### 2. Select the manual mode.

When you turn on the console, the manual mode will be selected. If you have selected a program, reselect the manual mode by pressing any of the Programs buttons repeatedly until a track appears in the left display.

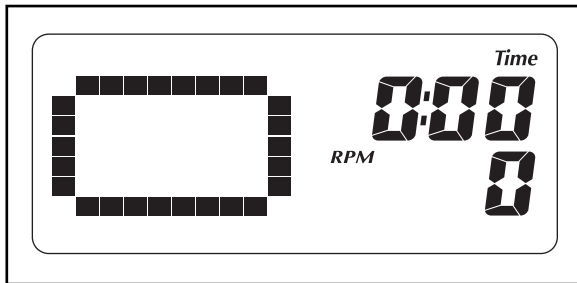

### 3. Begin pedaling and change the resistance of the pedals as desired.

As you pedal, change the resistance of the pedals by pressing the OneTouch Resistance buttons. There are ten resistance levels. Note: After you press the buttons, it will take a moment for the pedals to reach the selected resistance level.



### 4. Follow your progress with the displays.

**The upper right display** can show the elapsed time, the distance (total revolutions) you have pedaled, the approximate number of calories you have burned, and the approximate number of grams of carbs you have burned. The display will change modes every few seconds.



**The lower right display** can show your pedaling pace (in revolutions per minute) and the resistance level of the pedals. The display will change modes every few seconds. The display will also show your heart rate when you use the handgrip pulse sensor (see step 5 on page 16).



**The left display** will show a track representing 1/4 mile. As you exercise, indicators will appear in succession around the track until the entire track appears.

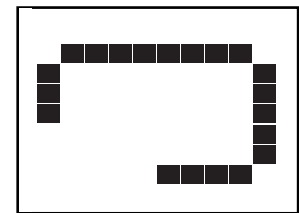

The track will then disappear and the indicators will again begin to appear in succession.

To change the display mode, press the Display button repeatedly until the desired exercise information appears in the upper or lower right display. After several seconds, the display will change modes automatically as before.

To view the total distance pedaled since the elliptical exerciser was purchased, press the Odometer button. The information will appear in the display for a few seconds. To view the trip distance, press the Odometer button a second time. To reset the trip distance, hold down the Odometer button for a few seconds. Note: The number on the right side of the display multiplied by the number on the left side equals the total distance or the trip distance.

5. **Measure your heart rate if desired.**

**If there are sheets of clear plastic on the metal contacts on the handgrip pulse sensor, remove the plastic. In addition, make sure that your hands are clean. To measure your heart rate, hold the handgrip pulse sensor with your palms resting against the metal contacts. Avoid moving your hands or gripping the contacts tightly.**

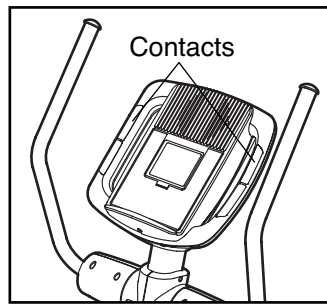

When your pulse is detected, a heart-shaped symbol will flash in the display each time your heart beats and then your heart rate will be shown. For the most accurate heart rate reading, hold the contacts for at least 15 seconds.

If your heart rate is not shown, make sure that your hands are positioned as described. Be careful not to move your hands excessively or to squeeze the metal contacts too tightly. For optimal performance, clean the metal contacts using a soft cloth; **never use alcohol, abrasives, or chemicals to clean the contacts.**

6. **Turn on the fan if desired.**

To turn on the fan at high speed, press the Fan button. To turn on the fan at low speed, press the Fan button a second time. To select the auto mode, press the Fan button a third time; while the auto mode is selected, the speed of the fan will automatically increase or decrease as you increase or decrease your pedaling speed.

Pivot the thumb tab on the right side of the fan to adjust the fan angle.

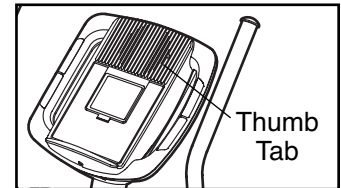

To turn off the fan, press the Fan button again. Note: If the pedals do not move for about thirty seconds, the fan will automatically turn off to conserve the batteries.

7. **When you are finished exercising, the console will turn off automatically.**

If the pedals do not move for several seconds, a series of tones will sound and the console will pause.

If the pedals do not move for about five minutes, the console will turn off and the displays will be reset.



## HOW TO USE A PRESET PROGRAM

1. **Press any button on the console or begin pedaling to turn on the console.**

See step 1 on page 15.

2. **Select a preset program.**

To select one of the four preset programs, press the Weight Loss, the Aerobic 1, the Aerobic 2, or the Performance button on the left side of the console.

When you select a preset program, the name of the program and the maximum resistance level will appear in the display for a few seconds. A profile of the resistance levels of the program will also scroll across the left side of the display.

3. **Begin pedaling to start the program.**

Each program is divided into 30 one-minute segments. One resistance level and one target pace setting is programmed for each segment. Note: The same resistance level and/or target pace setting may be programmed for consecutive segments.

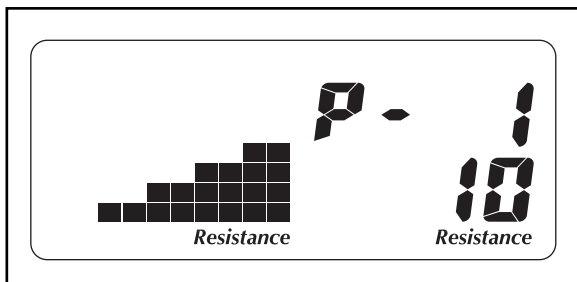

During the program, the program profile will show your progress (see the drawing above). The flashing segment of the profile represents the current segment of the program. The height of the flashing segment indicates the resistance level for the current segment. At the end of each segment of the program, a series of tones will sound and the next segment of the profile will begin to flash. If a different resistance level is programmed for the next segment, the resistance level will appear in the display for a few seconds to alert you. The resistance of the pedals will then change.

During the program, the program target pacer will prompt you to keep your pedaling pace near the target pace setting for the current segment. When a left indicator "faster" lights, increase your pace; when a right indicator "slower" lights, decrease your pace. When the center indicator lights, maintain your current pace. **Important: The program target pacer is intended only to provide a goal. Make sure to pedal at a pace that is comfortable for you.**

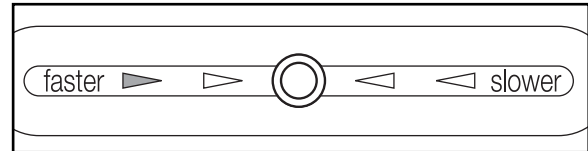

If the resistance level for the current segment is too high or too low, you can manually override the resistance level by pressing the OneTouch Resistance buttons. However, when the current segment ends, the resistance of the pedals will automatically adjust to the resistance level for the next segment.

If you stop pedaling for several seconds, a series of tones will sound and the program will pause. To restart the program, simply resume pedaling. The program will continue until the last segment of the program ends.

4. **Follow your progress with the displays.**

See step 4 on page 15.

5. **Measure your heart rate if desired.**

See step 5 on page 16.

6. **Turn on the fan if desired.**

See step 6 on page 16.

7. **When you are finished exercising, the console will turn off automatically.**

See step 7 on page 16.

## HOW TO USE A HEART RATE PROGRAM

1. **Press any button on the console or begin pedaling to turn on the console.**

See step 1 on page 15.

2. **Select a heart rate program.**

To select one of the heart rate programs, press the Heart Rate 1 or the Heart Rate 2 button on the left side of the console.

3. **Enter a target heart rate setting.**

A few seconds after you select a heart rate program, the target heart rate setting for the program will flash in the lower right display.



**During heart rate program 1**, the same target heart rate setting will be programmed for all segments of the program. If you have selected heart rate program 1, press the increase and decrease buttons above the Heart Rate Program buttons to enter the desired target heart rate setting (see EXERCISE INTENSITY on page 21).

**During heart rate program 2**, different target heart rate settings will be programmed for different segments of the program. If you have selected heart rate program 2, press the increase and decrease buttons above the Heart Rate Program buttons to enter the desired maximum target heart rate setting for the program (see EXERCISE INTENSITY on page 21).

4. **Hold the handgrip pulse sensor.**

It is not necessary to hold the handgrip pulse sensor continuously during heart rate programs; however, you should hold the handgrip pulse sensor frequently for the programs to operate properly. **Each time you hold the handgrip pulse sensor, keep your hands on the metal contacts for at least 30 seconds.**

5. **Begin pedaling to start the program.**

**Heart rate program 1** is divided into 40 one-minute segments. Note: For a shorter workout, stop exercising or select a different program before the program ends.

**Heart rate program 2** is divided into 30 one-minute segments. One target heart rate setting is programmed for each segment. Note: The same target heart rate setting may be programmed for consecutive segments.

During the program, the program profile in the display will show your progress. The flashing segment of the profile represents the current segment of the program. The height of the flashing segment indicates the target heart rate setting for the current segment. At the end of each segment of the program, a series of tones will sound and the next segment of the profile will begin to flash.

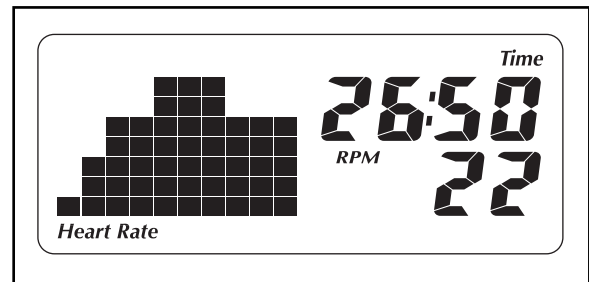

**During both programs**, the console will regularly compare your heart rate to the target heart rate setting for the current segment of the program. If your heart rate is too far below or above the target heart rate setting, the resistance of the pedals will automatically increase or decrease to bring your heart rate closer to the target heart rate setting. Each time the resistance changes, the resistance level will appear in the display for a few seconds to alert you.

While you exercise, the program target pacer will prompt you to maintain a constant pedaling speed. When a left indicator “faster” lights, increase your pace; when a right indicator “slower” lights, decrease your pace. When the center indicator lights, maintain your current pace.

**Important: The program target pacer is intended only to provide a goal. Make sure to pedal at a pace that is comfortable for you.**

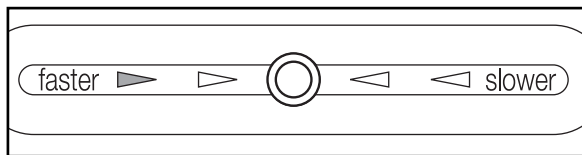

If the resistance level for the current segment is too high or too low, you can manually override the resistance level by pressing the OneTouch Resistance buttons. However, when the console compares your heart rate to the target heart rate setting, the resistance of the pedals may automatically increase or decrease to bring your heart rate closer to the target heart rate setting.

If you stop pedaling for several seconds, a series of tones will sound and the program will pause. To restart the program, simply resume pedaling. The program will continue until the last segment of the program ends.

**6. Follow your progress with the displays.**

See step 4 on page 15.

**7. Turn on the fan if desired.**

See step 6 on page 16.

**8. When you are finished exercising, the console will turn off automatically.**

See step 7 on page 16.

## HOW TO USE AN IFIT PROGRAM

**1. Press any button on the console or begin pedaling to turn on the console.**

See step 1 on page 15.

**2. Insert an iFIT card and select a program.**

To use an iFIT program, insert an iFIT card into the iFIT slot; make sure that the iFIT card is oriented so the metal contacts are face down and are facing the slot. When the iFIT card is properly inserted, the indicator next to the slot will light and the name of the iFit program will appear in the display.

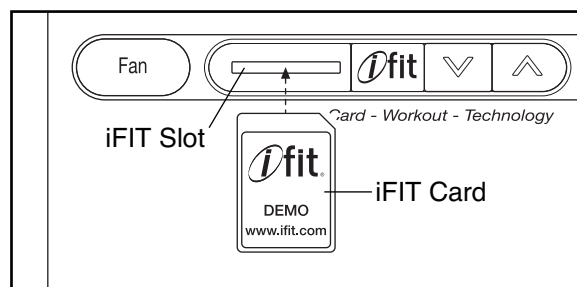

Next, select the desired program on the iFIT card by pressing the increase and decrease buttons next to the iFIT slot.

A moment after you select a program, the voice of a personal trainer will begin guiding you through your workout. iFIT programs work in the same way as preset programs. To use the program, see steps 3 to 7 on page 17.

**3. When you are finished exercising, remove the iFIT card.**

Remove the iFIT card when you are finished exercising. Store the iFIT card in a secure place.

## HOW TO USE THE STEREO SOUND SYSTEM

To play music or audio books through the console's stereo sound system while you exercise, plug the included audio cable into the jack on the console and into a jack on your MP3 player or CD player; **make sure that the audio cable is fully plugged in.**

Next, press the play button on your MP3 player or CD player. Adjust the volume of the speakers using the volume control on your MP3 player or CD player.

# MAINTENANCE AND TROUBLESHOOTING

Inspect and tighten all parts of the elliptical exerciser regularly. Replace any worn parts immediately.

To clean the elliptical exerciser, use a damp cloth and a small amount of mild soap. **Important: To avoid damage to the console, keep liquids away from the console and keep the console out of direct sunlight.**

## BATTERY REPLACEMENT

If the console displays become dim, the batteries should be replaced; most console problems are the result of low batteries. See assembly step 9 on page 9 for replacement instructions.

## HANDGRIP PULSE SENSOR TROUBLESHOOTING

If the handgrip pulse sensor does not function properly, see step 5 on page 16.

## HOW TO ELIMINATE RUBBING OF THE DISCS

If the Discs (12) rub against the Side Shields (14, 15) during use, make sure that the Center Foot (40) is installed in the Frame (1). If the Center Foot is installed, loosen the two indicated M8 x 25mm Bolt Sets (88) and the two #8 x 1/2" Screws (81) in each side of the elliptical exerciser.

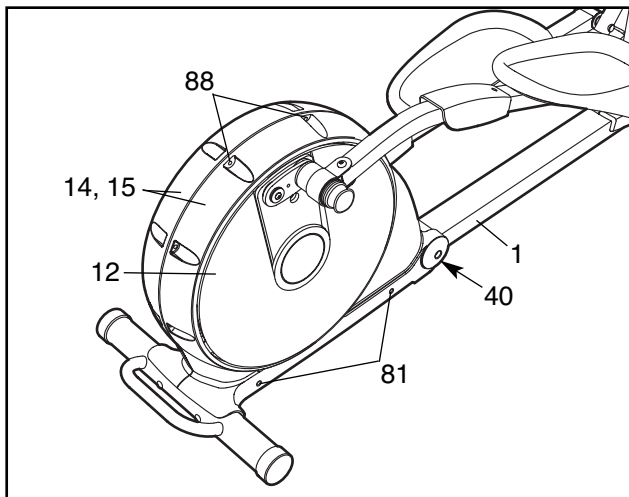

Adjust the position of the Side Shields (14, 15) until the Discs (12) no longer rub against them, and then tighten the M8 x 25mm Bolt Sets (88) and the #8 x 1/2" Screws (81).

## HOW TO ADJUST THE BELT

If the pedals slip while you are pedaling, even while the resistance is adjusted to the highest setting, the belt may need to be adjusted. To adjust the belt, first see assembly step 12 on page 11 and remove the left pedal arm and the left link arm.

Then, carefully pry off the left Disc Cover (13) using a flat screwdriver. Next, remove the four screws (not shown) from the center of the left Disc (12). Gently rotate the Disc Cover and the Disc away from the elliptical exerciser.

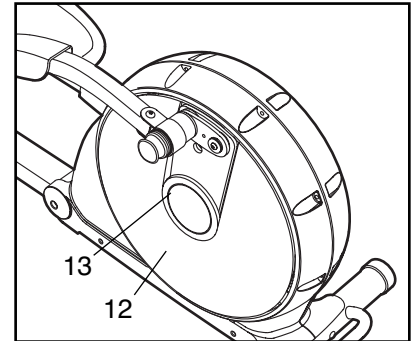

Loosen, but do not remove, the three indicated screws (A). Insert the shaft of a screwdriver downward between the Idler (47) and the Idler Pulley (48). Pull the top of the screwdriver toward the front of the elliptical exerciser until the Belt (74) is tight. Then, tighten the three screws.

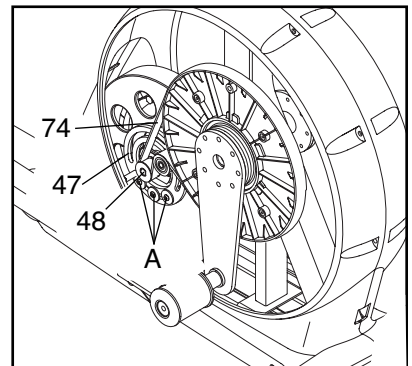

Reattach the left disc with the four screws and then reattach the left disc cover. Next, see assembly step 12 on page 11 and reattach the left pedal arm and the left link arm.

# EXERCISE GUIDELINES

**⚠ WARNING:** Before beginning this or any exercise program, consult your physician. This is especially important for persons over the age of 35 or persons with pre-existing health problems.

The pulse sensor is not a medical device. Various factors may affect the accuracy of heart rate readings. The pulse sensor is intended only as an exercise aid in determining heart rate trends in general.

These guidelines will help you to plan your exercise program. For detailed exercise information, obtain a reputable book or consult your physician. Remember, proper nutrition and adequate rest are essential for successful results.

## EXERCISE INTENSITY

Whether your goal is to burn fat or to strengthen your cardiovascular system, exercising at the proper intensity is the key to achieving results. You can use your heart rate as a guide to find the proper intensity level. The chart below shows recommended heart rates for fat burning and aerobic exercise.

165	155	145	140	130	125	115	♥
145	138	130	125	118	110	103	♥
125	120	115	110	105	95	90	♥
<hr/>							
20	30	40	50	60	70	80	

To find the proper intensity level, find your age at the bottom of the chart (ages are rounded off to the nearest ten years). The three numbers listed above your age define your “training zone.” The lowest number is the heart rate for fat burning, the middle number is the heart rate for maximum fat burning, and the highest number is the heart rate for aerobic exercise.

**Burning Fat**—To burn fat effectively, you must exercise at a low intensity level for a sustained period of time. During the first few minutes of exercise, your body uses *carbohydrate calories* for energy. Only after the first few minutes of exercise does your body begin to use stored *fat calories* for energy. If your goal is to burn fat, adjust the intensity of your exercise until your heart rate is near the lowest number in your training zone. For maximum fat burning, exercise with your heart rate near the middle number in your training zone.

**Aerobic Exercise**—If your goal is to strengthen your cardiovascular system, you must perform aerobic exercise, which is activity that requires large amounts of oxygen for prolonged periods of time. For aerobic exercise, adjust the intensity of your exercise until your heart rate is near the highest number in your training zone.

## WORKOUT GUIDELINES

**Warming up**—Start with 5 to 10 minutes of stretching and light exercise. A warm-up increases your body temperature, heart rate, and circulation in preparation for exercise.

**Training Zone Exercise**—Exercise for 20 to 30 minutes with your heart rate in your training zone. (During the first few weeks of your exercise program, do not keep your heart rate in your training zone for longer than 20 minutes.) Breathe regularly and deeply as you exercise—never hold your breath.

**Cooling down**—Finish with 5 to 10 minutes of stretching. Stretching increases the flexibility of your muscles and helps to prevent post-exercise problems.

## EXERCISE FREQUENCY

To maintain or improve your condition, complete three workouts each week, with at least one day of rest between workouts. After a few months of regular exercise, you may complete up to five workouts each week, if desired. Remember, the key to success is to make exercise a regular and enjoyable part of your everyday life.

## SUGGESTED STRETCHES

The correct form for several basic stretches is shown at the right. Move slowly as you stretch—never bounce.

### 1. Toe Touch Stretch

Stand with your knees bent slightly and slowly bend forward from your hips. Allow your back and shoulders to relax as you reach down toward your toes as far as possible. Hold for 15 counts, then relax. Repeat 3 times. Stretches: Hamstrings, back of knees and back.

### 2. Hamstring Stretch

Sit with one leg extended. Bring the sole of the opposite foot toward you and rest it against the inner thigh of your extended leg. Reach toward your toes as far as possible. Hold for 15 counts, then relax. Repeat 3 times for each leg. Stretches: Hamstrings, lower back and groin.

### 3. Calf/Achilles Stretch

With one leg in front of the other, reach forward and place your hands against a wall. Keep your back leg straight and your back foot flat on the floor. Bend your front leg, lean forward and move your hips toward the wall. Hold for 15 counts, then relax. Repeat 3 times for each leg. To cause further stretching of the achilles tendons, bend your back leg as well. Stretches: Calves, achilles tendons and ankles.

### 4. Quadriceps Stretch

With one hand against a wall for balance, reach back and grasp one foot with your other hand. Bring your heel as close to your buttocks as possible. Hold for 15 counts, then relax. Repeat 3 times for each leg. Stretches: Quadriceps and hip muscles.

### 5. Inner Thigh Stretch

Sit with the soles of your feet together and your knees outward. Pull your feet toward your groin area as far as possible. Hold for 15 counts, then relax. Repeat 3 times. Stretches: Quadriceps and hip muscles.

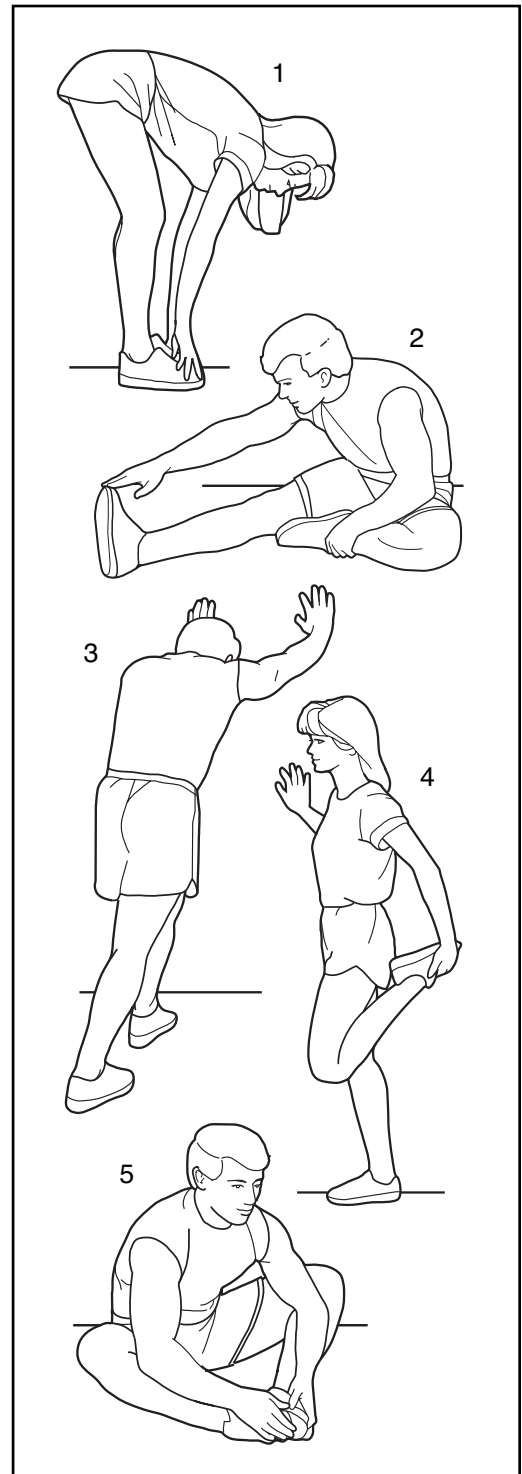

---

# NOTES

# PART LIST—Model No. 831.23765.1

R1107A

Key No.	Qty.	Description	Key No.	Qty.	Description
1	1	Frame	46	1	Pillow Block
2	1	Folding Frame	47	1	Idler
3	1	Rear Stabilizer	48	1	Idler Pulley
4	1	Front Stabilizer	49	1	Eddy Motor
5	1	Left Pedal Bracket	50	1	Reed Switch/Wire
6	1	Right Pedal Bracket	51	1	Clamp
7	4	Upper Bushing Assembly	52	2	Adjustment Knob
8	2	Upper Body Arm Endcap	53	4	Pivot Arm Bushing
9	2	Upper Body Leg Spacer	54	4	Link Snap Ring
10	1	Upright	55	1	Left Crank Arm
11	1	Console	56	1	Crank Arm Spacer
12	2	Disc	57	1	Large Pulley
13	2	Disc Cover	58	2	Crank Flange
14	1	Left Side Shield	59	2	Crank Bearing Assembly
15	1	Right Side Shield	60	1	Crank Spacer
16	4	Stabilizer Endcap	61	1	Crank
17	2	Wheel	62	2	Crank Snap Ring
18	2	Link Axle	63	2	Flange Screw
19	1	Left Upright Cover	64	1	Lower Wire Harness
20	1	Right Upright Cover	65	1	Upper Wire Harness
21	2	Pivot Bushing	66	2	Axle Cover
22	1	Left Upper Body Arm	67	4	Bushing Assembly
23	1	Right Upper Body Arm	68	2	Brass Bushing
24	1	Left Upper Body Leg	69	1	Latch Bracket
25	1	Latch Axle	70	1	Pivot Axle
26	1	Left Rear Upper Body Cover	71	1	Upper Body Axle
27	1	Left Front Upper Body Cover	72	1	Right Upper Body Leg
28	1	Right Rear Upper Body Cover	73	2	Upper Body Leg Endcap
29	1	Right Front Upper Body Cover	74	1	Belt
30	2	Link Arm	75	2	Foam
31	14	M8 x 23mm Washer	76	1	Frame Cap
32	2	Pedal Arm	77	2	Transfer Handle Endcap
33	8	M6 Washer	78	16	#8 x 3/4" Screw
34	1	Left Pedal	79	4	#8 x 3/4" Flat Head Screw
35	1	Right Pedal	80	2	Wave Washer
36	1	Left Frame Cover	81	6	#8 x 1/2" Screw
37	1	Right Frame Cover	82	4	M10 Nylon Locknut
38	1	Latch Spring	83	8	M6 x 12mm Button Screw
39	2	Pedal Arm Cover	84	6	M8 x 16mm Patch Screw
40	1	Center Foot	85	14	M8 x 20mm Button Screw
41	1	Latch Button	86	6	M8 x 20mm Patch Screw
42	4	Link Bearing	87	4	M8 x 32mm Button Screw
43	2	Link Arm Pad	88	5	M8 x 25mm Bolt Set
44	1	Eddy Mechanism	89	2	Large Wave Washer
45	1	Eddy Crank Assembly	90	6	M8 x 40mm Button Screw



Key No.	Qty.	Description	Key No.	Qty.	Description
91	2	M10 x 60mm Button Bolt	102	2	Adjustment Spacer
92	9	#8 x 1/2" Blunt Screw	103	4	Large Snap Ring
93	4	M10 x 80mm Button Screw	104	2	M10 x 58mm Patch Bolt
94	10	M8 Nylon Locknut	105	2	31mm Wave Washer
95	4	M8 Washer	106	2	Adjustment Spring
96	2	M8 x 12mm Button Screw	107	2	Link Arm Bracket
97	10	M8 Split Washer	108	2	Adjustment Arm
98	1	Right Crank Arm	*	–	User's Manual
99	4	M10 Washer	*	–	Hex Key
100	1	Side Shield Fastener	*	–	Grease Packet
101	2	Adjustment Pin			

Note: Specifications are subject to change without notice. See the back cover of this manual for information about ordering replacement parts. \*These parts are not illustrated.

# EXPLODED DRAWING A—Model No. 831.23765.1

R1107A

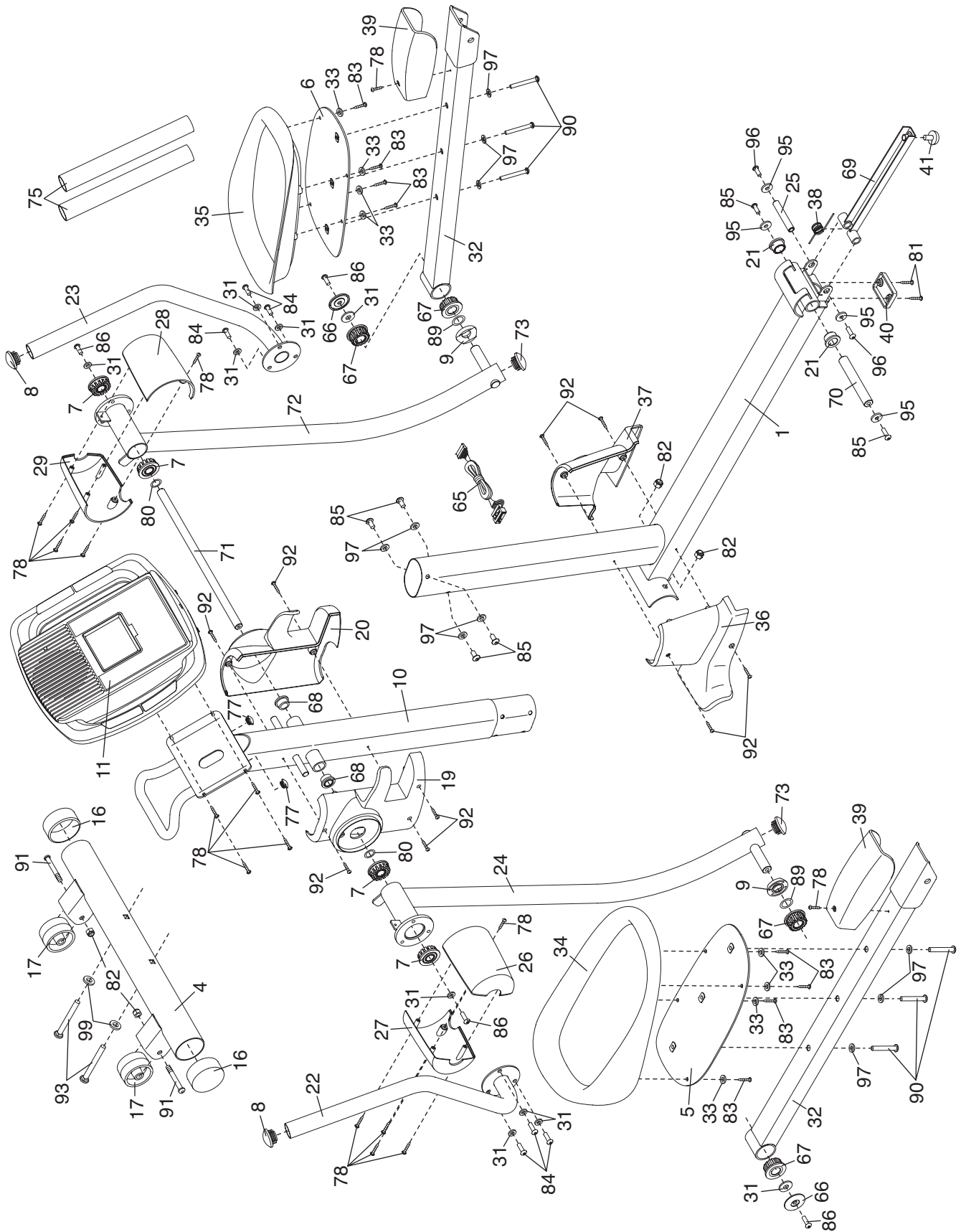

# EXPLODED DRAWING B—Model No. 831.23765.1

R1107A

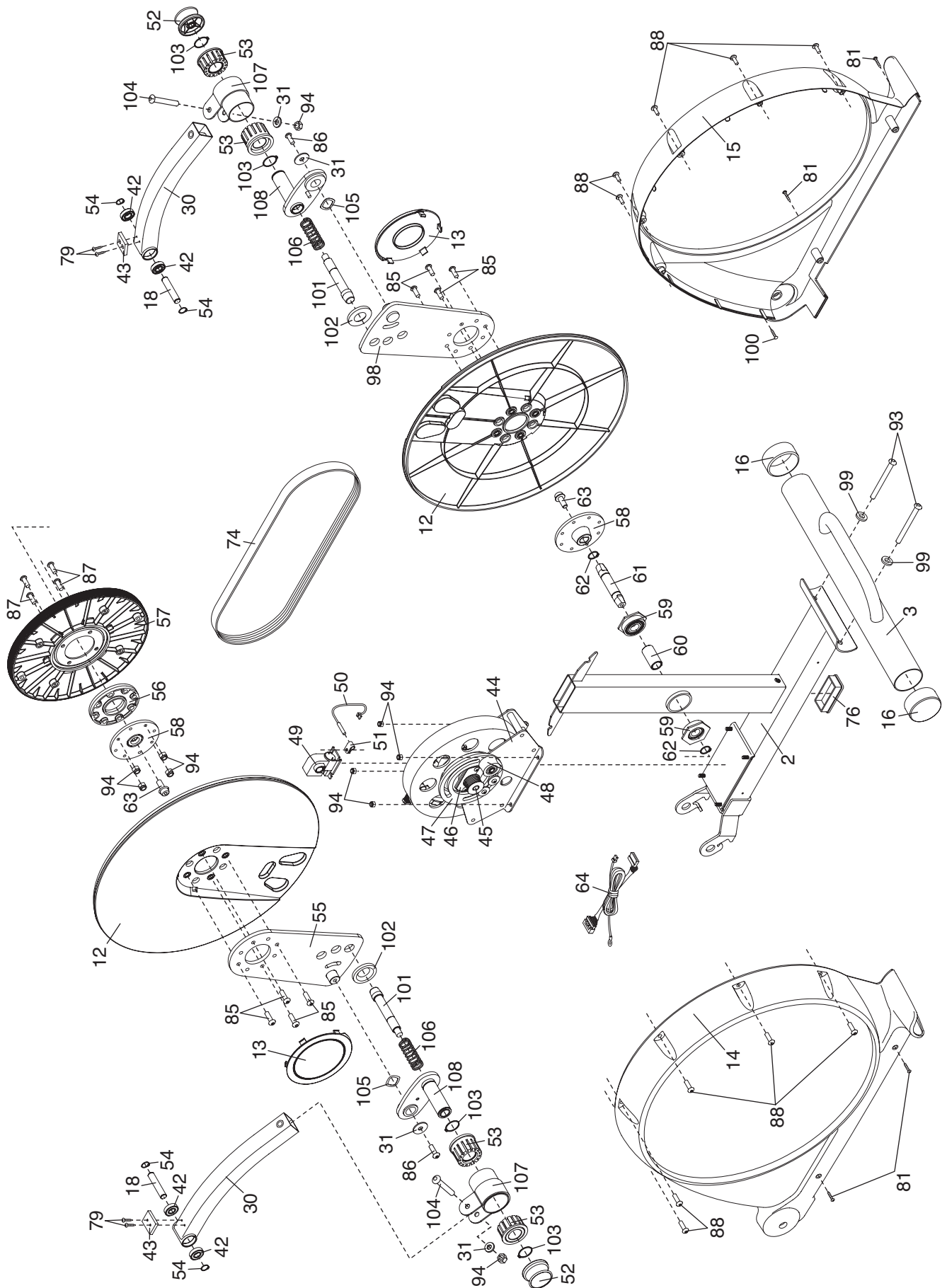

# ORDERING REPLACEMENT PARTS

To order replacement parts, please see the front cover of this manual. To help us assist you, be prepared to provide the following information when contacting us:

- the model number and serial number of the product (see the front cover of this manual)
- the name of the product (see the front cover of this manual)
- the key number and description of the replacement part(s) (see the PART LIST and the EXPLODED DRAWING near the end of this manual)

## LIMITED WARRANTY

ICON Health & Fitness, Inc. (ICON) warrants this product to be free from defects in workmanship and material, under normal use and service conditions, for a period of one (1) year from the date of purchase. This warranty extends only to the original purchaser. ICON's obligation under this warranty is limited to replacing or repairing, at ICON's option, the product through one of its authorized service centers. All repairs for which warranty claims are made must be pre-authorized by ICON. If the product is shipped to a service center, freight charges to and from the service center will be the customer's responsibility. For in-home service, the customer will be responsible for a minimal trip charge. This warranty does not extend to any product or damage to a product caused by or attributable to freight damage, abuse, misuse, improper or abnormal usage or repairs not provided by an ICON authorized service center; products used for commercial or rental purposes; or products used as store display models. No other warranty beyond that specifically set forth above is authorized by ICON.

ICON is not responsible or liable for indirect, special or consequential damages arising out of or in connection with the use or performance of the product or damages with respect to any economic loss, loss of property, loss of revenues or profits, loss of enjoyment or use, costs of removal or installation or other consequential damages of whatsoever nature. Some states do not allow the exclusion or limitation of incidental or consequential damages. Accordingly, the above limitation may not apply to you.

The warranty extended hereunder is in lieu of any and all other warranties and any implied warranties of merchantability or fitness for a particular purpose is limited in its scope and duration to the terms set forth herein. Some states do not allow limitations on how long an implied warranty lasts. Accordingly, the above limitation may not apply to you.

This warranty gives you specific legal rights. You may also have other rights which vary from state to state.

**ICON HEALTH & FITNESS, INC., 1500 S. 1000 W., LOGAN, UT 84321-9813**

## Free Manuals Download Website

<http://myh66.com>

<http://usermanuals.us>

<http://www.somanuals.com>

<http://www.4manuals.cc>

<http://www.manual-lib.com>

<http://www.404manual.com>

<http://www.luxmanual.com>

<http://aubethermostatmanual.com>

Golf course search by state

<http://golfingnear.com>

Email search by domain

<http://emailbydomain.com>

Auto manuals search

<http://auto.somanuals.com>

TV manuals search

<http://tv.somanuals.com>