



GRT 310

Model No. NTBE01100

Serial No. _____

Write the serial number in the space above for reference.

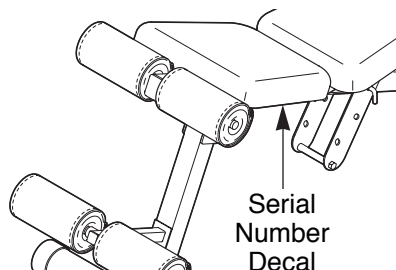

USER'S MANUAL

QUESTIONS?

As a manufacturer, we are committed to providing complete customer satisfaction. If you have questions, or if there are missing parts, we will guarantee complete satisfaction through assistance from our factory.

TO AVOID UNNECESSARY DELAYS, PLEASE CALL DIRECT TO OUR TOLL-FREE CUSTOMER HOT LINE. The trained technicians on our customer hot line will provide immediate assistance, free of charge to you.

CUSTOMER HOT LINE:

1-888-825-2588

Mon.-Fri., 6 a.m.-6 p.m. MST

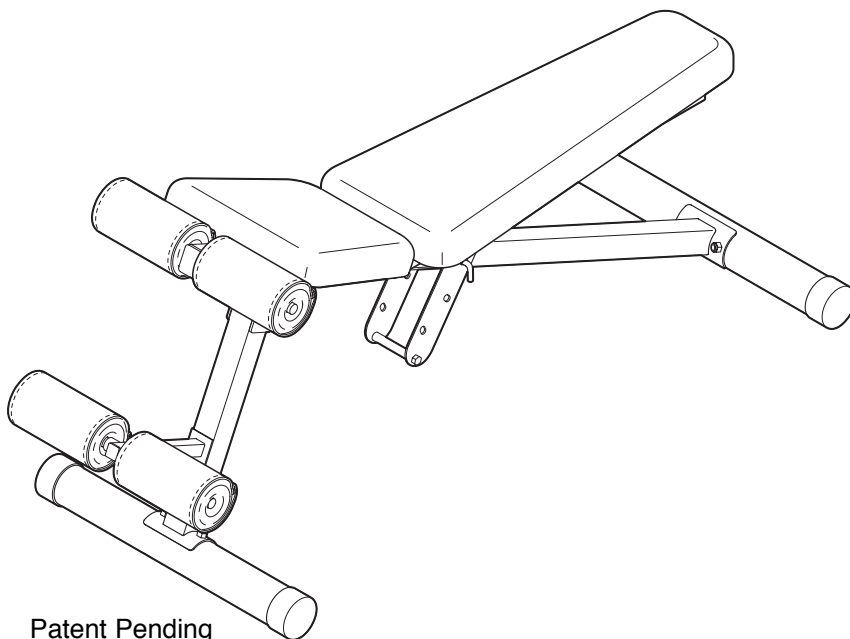

CAUTION

Read all precautions and instructions in this manual before using this equipment. Save this manual for future reference.



Visit our website at

www.nordictrack.com

new products, prizes,
fitness tips, and much more!

Table of Contents

Important Precautions	2
Before You Begin	3
Part Identification Chart	4
Assembly	4
Adjusting the Weight Bench	7
Exercise Guidelines	8
Part List	10
Exploded Drawing	11
Ordering Replacement Parts	Back Cover
Limited Warranty	Back Cover

Important Precautions

⚠ WARNING: To reduce the risk of serious injury, read the following important precautions before using the weight bench.

1. Read all instructions in this manual before using the weight bench.
2. Use the weight bench only as described in this manual.
3. It is the responsibility of the owner to ensure that all users of the weight bench are adequately informed of all precautions.
4. Use the weight bench only on a level surface. Cover the floor beneath the weight bench for protection of the floor.
5. Inspect and tighten all parts each time you use the weight bench. Replace any worn parts immediately.
6. Keep children under the age of 12 and pets away from the weight bench at all times.
7. Always wear athletic shoes for foot protection while exercising.
8. The weight bench is intended for home use only. Do not use the weight bench in any commercial, rental or institutional setting.
9. The weight bench is designed to support a maximum of 360 pounds, including the user and dumbbells.
10. If you feel pain or dizziness at any time while exercising, stop immediately and begin cooling down.
11. Keep hands and feet away from moving parts.
12. Always make sure the locking pin is fully inserted and in the proper position for the exercise you are performing.

⚠ WARNING: Before beginning this or any exercise program, consult your physician. This is especially important for persons over the age of 35 or persons with pre-existing health problems. Read all instructions before using. ICON assumes no responsibility for personal injury or property damage sustained by or through the use of this product.

Before You Begin

Thank you for selecting the versatile NordicTrack® GRT310. The NordicTrack® GRT310 is designed to help you develop every major muscle group of the body. Whether your goal is a shapely figure, dramatic muscle size and strength, or a healthier cardiovascular system, the NordicTrack® GRT310 will help you achieve the specific results you want.

For your benefit, read this manual carefully before using the NordicTrack® GRT310. If you have additional questions, please call our Customer Service

Department toll-free at 1-888-825-2588, Monday through Friday, 6 a.m. until 6 p.m. Mountain Time (excluding holidays). To help us assist you, please note the product model number and serial number before calling. The model number is NTBE01100. The serial number can be found on a decal attached to the weight bench (see the front cover of this manual).

Before reading further, please review the drawing below and familiarize yourself with the parts that are labeled.

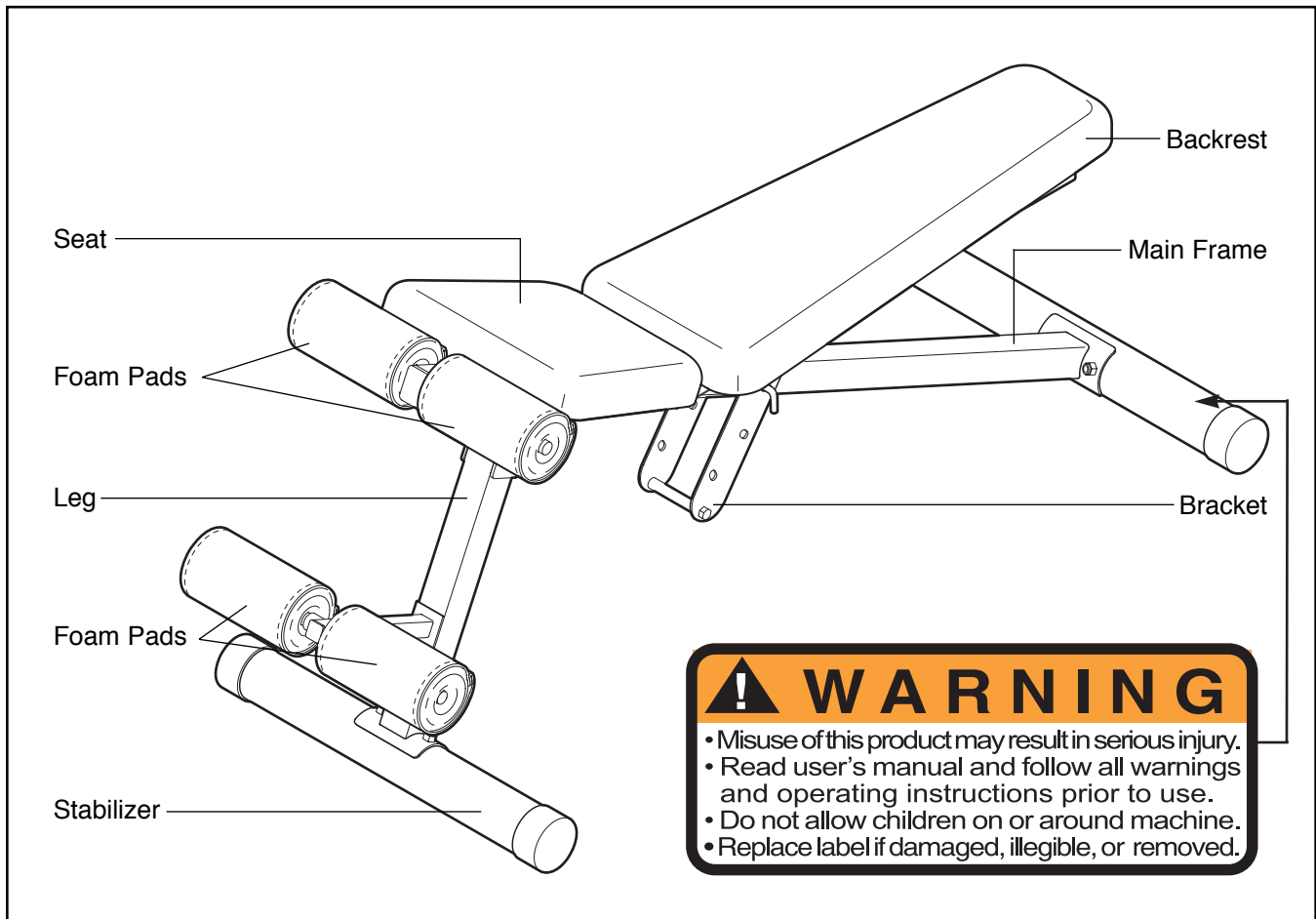

The decal shown above has been placed on the weight bench. If the decal is missing, or if it is not legible, please call our Customer Service Department toll-free at 1-888-825-2588, Monday through Friday, 6 a.m. until 6 p.m. Mountain Time (excluding holidays), to order a free replacement decal. Apply the replacement decal to the location shown.

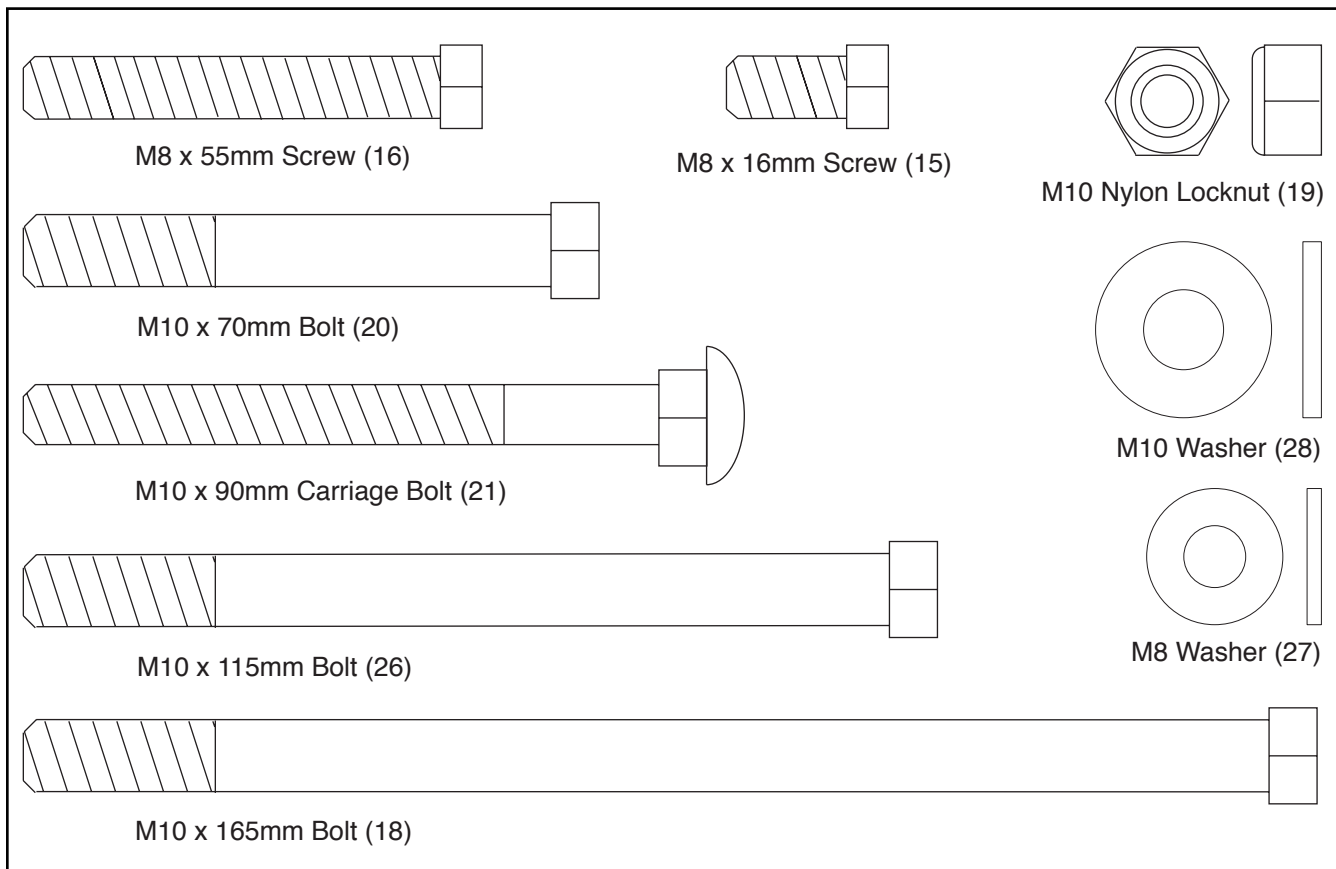





Assembly

Before beginning assembly, carefully read the following information and instructions:

- Assembly requires two people.
- Place all parts in a cleared area and remove the packing materials. Do not dispose of the packing materials until assembly is completed.
- Tighten all parts as you assemble them, unless instructed to do otherwise.
- For help identifying the small parts, use the PART IDENTIFICATION CHART, above.
- As you assemble the weight bench, make sure all parts are oriented as shown in the drawings.

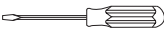
The following tools (not included) are required for assembly:

- **Two (2) adjustable wrenches** 
- **One (1) rubber mallet** 
- **One (1) standard screwdriver** 
- **One (1) phillips screwdriver** 
- **Lubricant, such as grease or petroleum jelly plus soapy water.**

Assembly will be more convenient if you have the following tools: A socket set, a set of open-end or closed-end wrenches, or a set of ratchet wrenches.

1. **Before assembling the bench, make sure you understand the information in the box on page 4.**

Press an Inner Cap (13) into the end of the Main Frame (1). Press two 76mm Round Endcaps (8) onto the ends of a Stabilizer (2).

Attach the Stabilizer (2) to the Main Frame (1) with two M10 x 90mm Carriage Bolts (21) and two M10 Nylon Locknuts (19). **Do not tighten the Nylon Locknuts yet. Note: The indentions in the Stabilizer should face the floor so that the warning decal is in the position shown.**

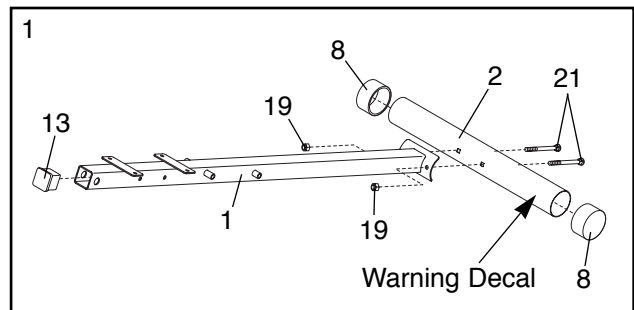

2. Press two 76mm Round Endcaps (8) onto the ends of the other Stabilizer (2). Press a 25mm Square Inner Cap (24) into the indicated part of the Leg (5).

Attach the Stabilizer (2) to the Leg (5) with two M10 x 90mm Carriage Bolts (21) and two M10 Nylon Locknuts (19).

Attach two Support Plates (22) to the Leg (5) with two M10 x 70mm Bolts (20) and two M10 Nylon Locknuts (19). **Do not tighten the Locknuts yet.**

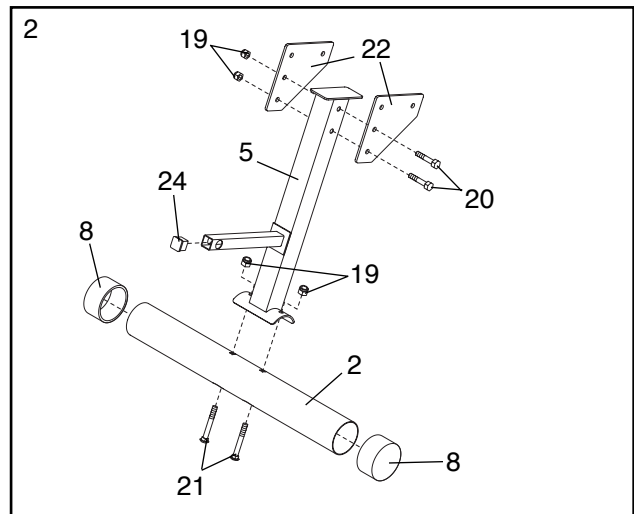

3. Attach the Main Frame (1) to the Support Plates (22) with two M10 x 70mm Bolts (20) and two M10 Nylon Locknuts (19). **Do not tighten the Locknuts yet.**

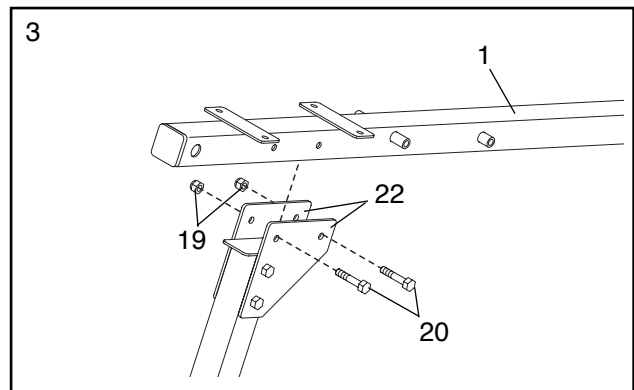

4. Press two 25mm x 40mm Inner Caps (14) into the ends of the Right and Left Backrest Frames (3, 4).

Be sure the Left and Right Backrest Frames (3, 4) are positioned as shown. Attach the Backrest (6) to the Backrest Frames with four M8 x 55mm Screws (16) and four M8 Washers (27). **Do not tighten the Screws yet.**

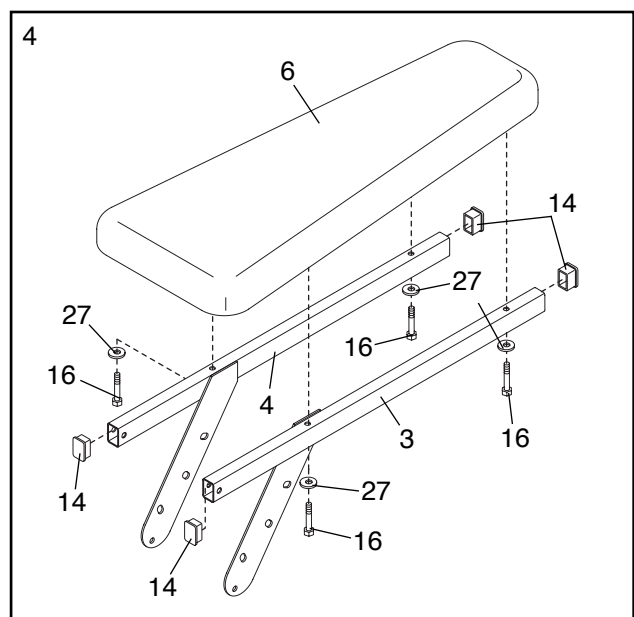

5. Lubricate an M10 x 165mm Bolt (18). Attach the Right and Left Backrest Frames (3, 4) to the forward tube in the Main Frame (1) with the Bolt, two M10 Washers (28), and an M10 Nylon Locknut (19). **Do not over tighten the Nylon Locknut; it must be easy to pivot the Backrest Frames.**

Tighten the Screws (16) used in step 4. Tighten the Nylon Locknuts (19) used in steps 1–3.

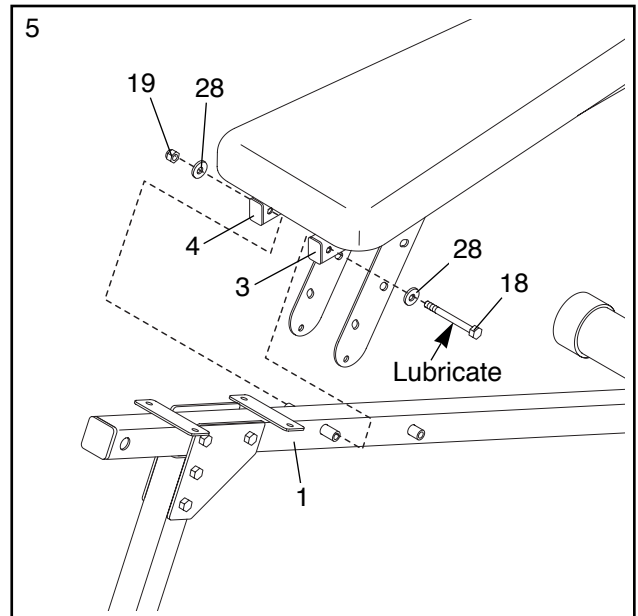

6. **Note that the brackets on the Backrest Frames (3, 4) have three sets of oval adjustment holes and one set of round holes.**

Position the Spacer (25) between the brackets on the Backrest Frames (3, 4) and line it up with the round holes. Insert an M10 x 115mm Bolt (26) through the round holes in the brackets and through the Spacer. Secure the Bolt with an M10 Nylon Locknut (19). **Note: The Spacer must be positioned under the Main Frame (1).**

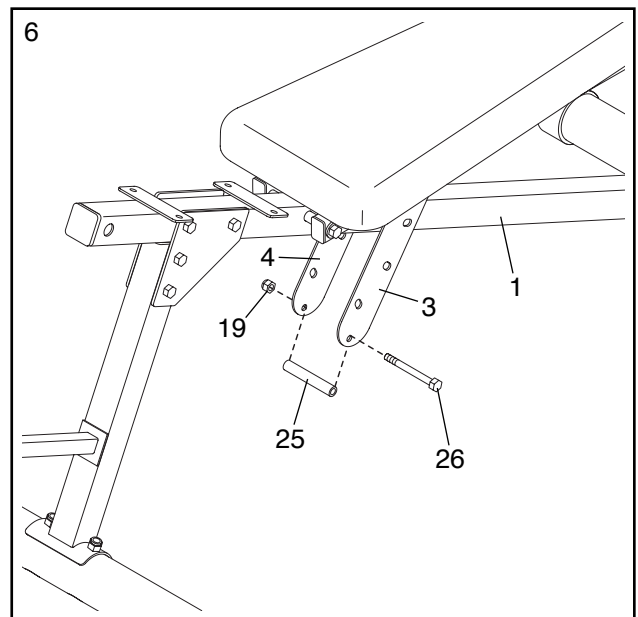

7. Attach the Seat (7) to the brackets on the Main Frame (1) with four M8 x 16mm Screws (15).

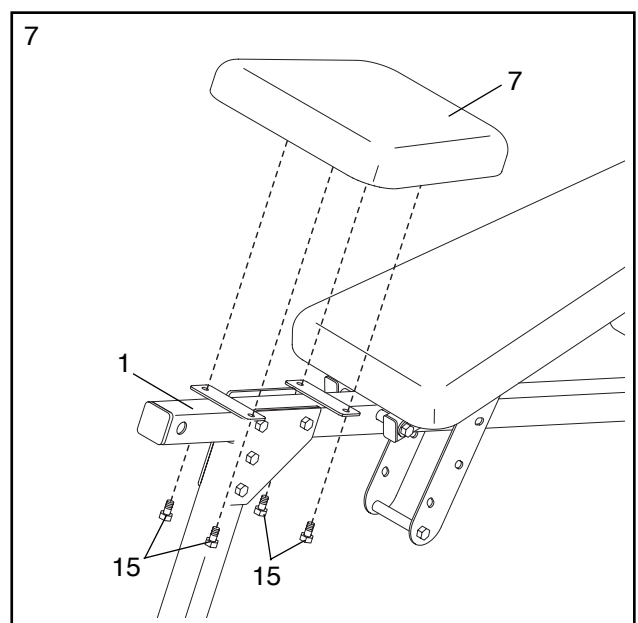

8. Press 19mm Round Inner Caps (12) into the ends of the two Pad Tubes (11).

Slide a Plastic Spacer (23) and a Foam Pad (9) onto one end of a Pad Tube (11). Slide the Pad Tube through the hole in the Leg (5). Slide a Plastic Spacer and a Foam Pad onto the other end of the Pad Tube.

Slide a Foam Pad (9) onto one end of the other Pad Tube (11). Slide the Pad Tube through the hole in the Main Frame (1). Slide a Foam Pad onto the other end of the Pad Tube.

Slide a Foam Pad Cover (10) onto each of the Foam Pads (9).

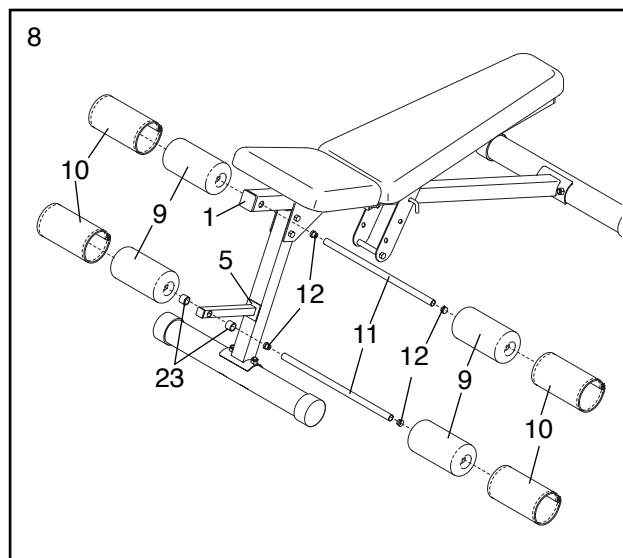

9. **Make sure that all parts of the weight bench are properly tightened. The use of the remaining parts will be explained below.**

Adjusting The Weight Bench

This section explains how to adjust the weight bench. See the EXERCISE GUIDELINES on page 8 for important information on how to get the most benefit from your exercise program. Also, refer to the accompanying exercise poster to see the correct form for each exercise.

Inspect and tighten all parts each time you use the weight bench. Replace any worn parts immediately. The weight bench can be cleaned with a damp cloth and a mild, non-abrasive detergent. Do not use solvents.

ADJUSTING THE BACKREST

The Backrest (6) can be used in a level position, two inclined positions, and a declined position. To adjust the Backrest to a level position or an inclined position, lift the Backrest, and insert the Locking Pin (17) through one set of adjustment holes in the Backrest Frames (3, 4) and through the welded tube in the Main Frame (1).

To use the Backrest (6) in a declined position, remove the Locking Pin (17) and lower the Backrest until it rests directly on the Main Frame (1). Re-insert the Locking Pin into a set of holes in the Backrest Frames (3, 4).

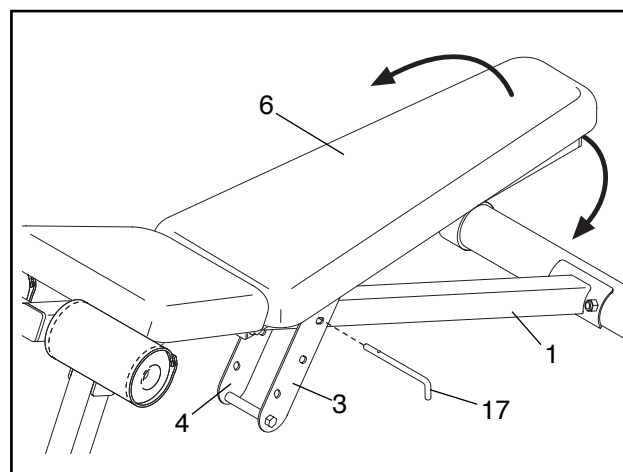

Exercise Guidelines

THE FOUR BASIC TYPES OF WORKOUTS

Muscle Building

The only way to increase the size and strength of your muscles is to push them close to their maximum capacity. When you progressively increase the intensity of your exercise, your muscles will continually adapt and grow. You can tailor the individual exercise to the proper intensity level in two ways:

- by changing the amount of weight used
- by changing the number of repetitions or sets performed (A “repetition” is one complete cycle of an exercise, such as one sit-up. A “set” is a series of repetitions).

The proper amount of weight for each exercise obviously depends upon the individual user. You must gauge your limits and select the amount of weight that is right for you. Begin with 3 sets of 8 repetitions for each exercise you perform. Rest for 3 minutes after each set. When you can complete 3 sets of 12 repetitions without difficulty, increase the amount of weight.

Toning

You can tone your muscles by pushing them to a moderate percentage of their capacity. Select a moderate amount of weight and increase the number of repetitions in each set. Complete as many sets of 15 to 20 repetitions as possible without discomfort. Rest for 1 minute after each set. Work your muscles by completing more sets rather than by using high amounts of weight.

Weight Loss

To lose weight, use a low amount of weight and increase the number of repetitions in each set. Exercise for 20 to 30 minutes, resting for a maximum of 30 seconds between sets.

Cross Training

Many people desire a complete and well-balanced fitness program, and cross training is a very efficient way to accomplish this. One example of a balanced program is:

- Plan weight training workouts on Monday, Wednesday and Friday.
- Plan 20 to 30 minutes of aerobic exercise, such as cycling, running or swimming on Tuesday and Thursday.
- Rest from both weight training and aerobic exercise for at least one full day each week to give your body time to regenerate.

The combination of weight training and aerobic exercise will reshape and strengthen your body plus develop your heart and lungs.

PERSONALIZING YOUR EXERCISE PROGRAM

Specifying the exact length of time for each workout, as well as the number of repetitions or sets for each exercise, is a highly individual matter. It is very important to avoid overdoing it during the first few months of your exercise program. You should progress at your own pace and be sensitive to your body's signals. If you experience pain or dizziness at any time while exercising, stop immediately and begin cooling down. Find out what is wrong before continuing. Remember that adequate rest and a proper diet are important factors in any exercise program.

WARMING UP

Begin each workout with 5 to 10 minutes of stretching and light exercise to warm up. Warming up prepares your body for more strenuous exercise by increasing circulation, raising your body temperature and delivering more oxygen to your muscles.

WORKING OUT

Each workout should include 6 to 10 different exercises. Select exercises for every major muscle group with emphasis on the areas that you want to develop the most. To give balance and variety to your workouts, vary the exercises from session to session.

Schedule your workouts for the time of day when your energy level is the highest. Each workout should be followed by at least one day of rest. Once you find the schedule that is right for you, stick with it.

EXERCISE FORM

You will gain the greatest benefits from exercising by maintaining proper form. This requires moving through the full range of motion for each exercise and moving only the appropriate parts of the body. Exercising in an uncontrolled manner will leave you feeling exhausted. On the exercise poster accompanying this manual, you will find photographs showing the correct form for several exercises. A description of each exercise is also provided, along with a list of the muscles affected. Refer to the muscle chart on page 9 to find the locations of the muscles.

The repetitions in each set should be performed smoothly and without pausing. The exertion stage of each repetition should last about half as long as the return stage. Proper breathing is important. Exhale during the exertion stage of each repetition and inhale during the return stroke. Never hold your breath.

You should rest for a short period of time after each set. The ideal resting periods are:

- Rest for three minutes after each set for a muscle building workout
- Rest for one minute after each set for a toning workout
- Rest for 30 seconds after each set for a weight loss workout

Plan to spend the first couple of weeks familiarizing yourself with the equipment and learning the proper form for each exercise.

COOLING DOWN

End each workout with 5 to 10 minutes of stretching. Include stretches for both your arms and legs. Move

slowly as you stretch and do not bounce. Ease into each stretch gradually and go only as far as you can without strain. Stretching at the end of each workout is very effective for increasing flexibility.

STAYING MOTIVATED

For motivation, keep a record of each workout. List the date, the exercises performed, the weight plus the numbers of sets and repetitions completed. Record your weight and key body measurements at the end of every month.

Remember, the key to achieving the greatest results is to make exercise a regular and enjoyable part of your everyday life.

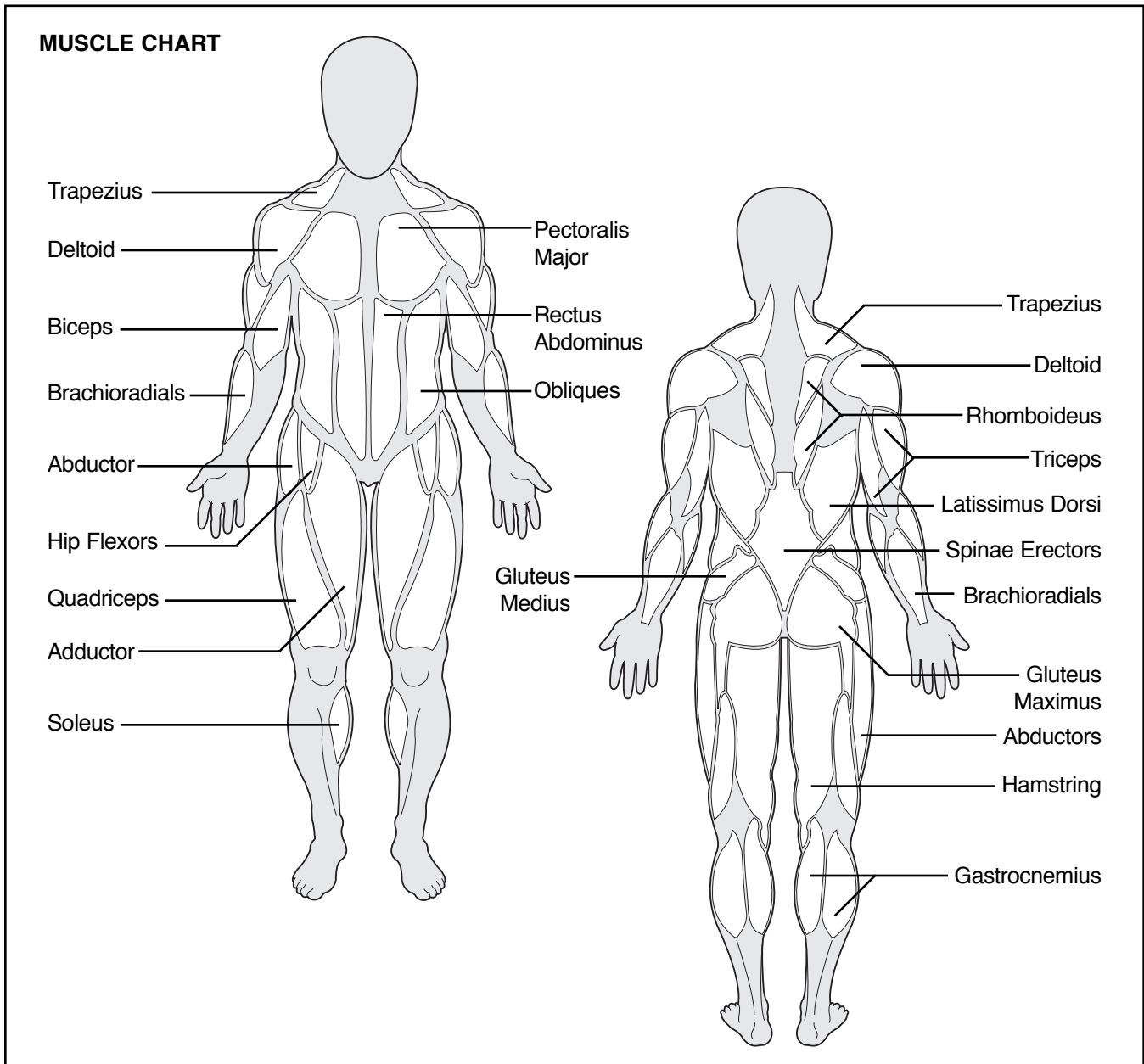

Key No.	Qty.	Description	Key No.	Qty.	Description
1	1	Main Frame	16	4	M8 x 55mm Screw
2	2	Stabilizer	17	1	Locking Pin
3	1	Right Backrest Frame	18	1	M10 x 165mm Bolt
4	1	Left Backrest Frame	19	10	M10 Nylon Locknut
5	1	Leg	20	4	M10 x 70mm Bolt
6	1	Backrest	21	4	M10 x 90mm Carriage Bolt
7	1	Seat	22	2	Support Plate
8	4	76mm Round Endcap	23	2	Plastic Spacer
9	4	Foam Pad	24	1	25mm Square Inner Cap
10	4	Foam Pad Cover	25	1	Spacer
11	2	Pad Tube	26	1	M10 x 115mm Bolt
12	4	19mm Round Inner Cap	27	4	M8 Washer
13	1	Inner Cap	28	2	M10 Washer
14	4	25mm x 40mm Inner Cap	#	1	User's Manual
15	4	M8 x 16mm Screw	#	1	Exercise Poster

Note: “#” indicates a non-illustrated part. Specifications are subject to change without notice. See the back cover of this manual for information about ordering replacement parts.

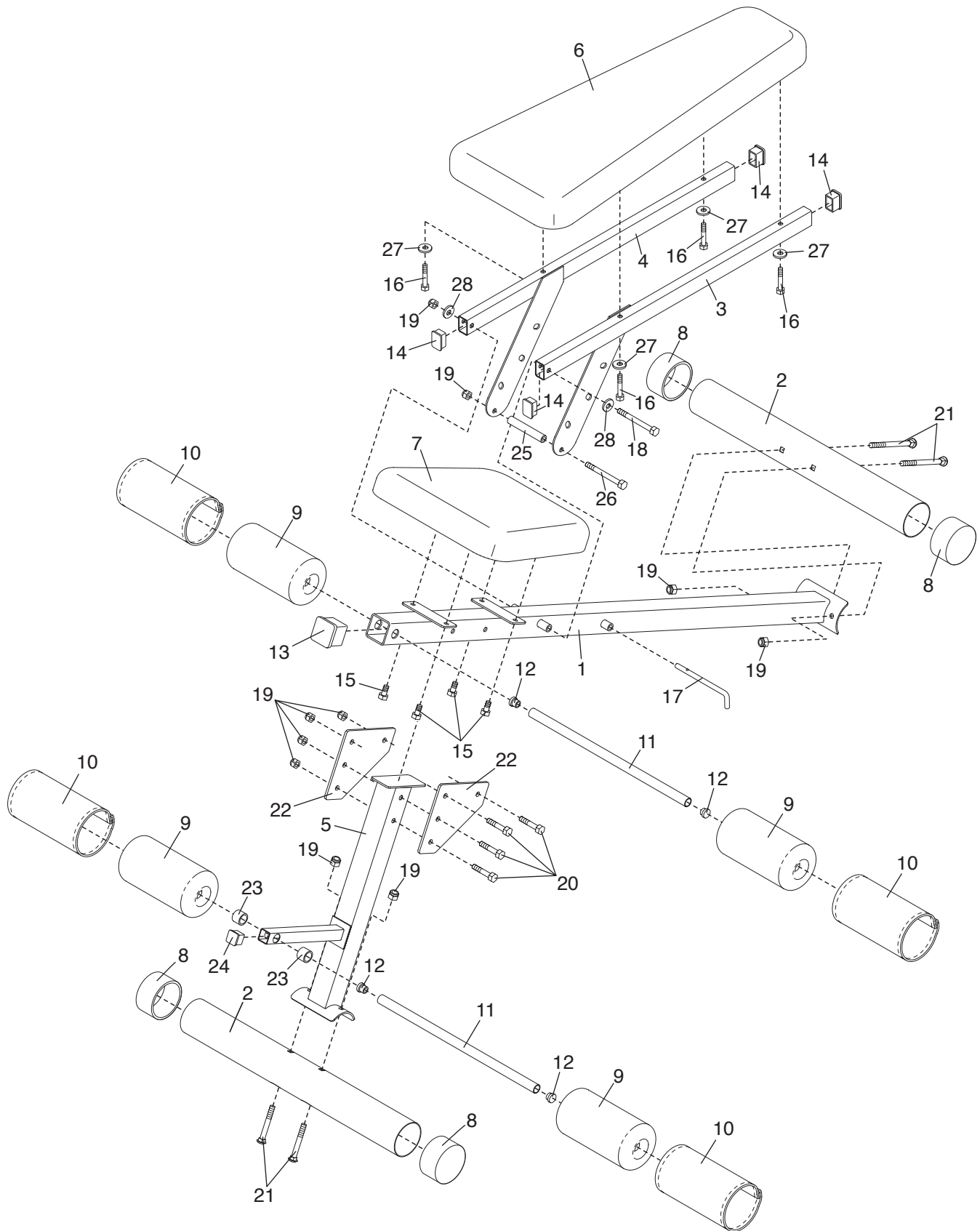

Ordering Replacement Parts

To order replacement parts, simply call our Customer Service Department toll-free at 1-888-825-2588, Monday through Friday, 6 a.m. until 6 p.m. Mountain Time (excluding holidays). To help us assist you, please be prepared to give the following information when calling:

1. The MODEL NUMBER of the product (NTBE01100)
2. The NAME of the product (NordicTrack® GRT310)
3. The SERIAL NUMBER of the product (see the front cover of this manual)
4. The KEY NUMBER and DESCRIPTION of the desired part(s) (see the PART LIST and the EXPLODED DRAWING in the center of this manual).

Limited Warranty

ICON Health & Fitness, Inc. (ICON), warrants this product to be free from defects in workmanship and material, under normal use and service conditions, for a period of ninety (90) days from the date of purchase. This warranty extends only to the original purchaser. ICON's obligation under this warranty is limited to replacing or repairing, at ICON's option, the product at one of its authorized service centers. All products for which warranty claim is made must be received by ICON at one of its authorized service centers with all freight and other transportation charges prepaid, accompanied by sufficient proof of purchase. All returns must be pre-authorized by ICON. This warranty does not extend to any product or damage to a product caused by or attributable to freight damage, abuse, misuse, improper or abnormal usage or repairs not provided by an ICON authorized service center, products used for commercial or rental purposes, or products used as store display models. No other warranty beyond that specifically set forth above is authorized by ICON.

ICON is not responsible or liable for indirect, special or consequential damages arising out of or in connection with the use or performance of the product or damages with respect to any economic loss, loss of property, loss of revenues or profits, loss of enjoyment or use, costs of removal, installation or other consequential damages of whatsoever nature. Some states do not allow the exclusion or limitation of incidental or consequential damages. Accordingly, the above limitation may not apply to you.

The warranty extended hereunder is in lieu of any and all other warranties and any implied warranties of merchantability or fitness for a particular purpose is limited in its scope and duration to the terms set forth herein. Some states do not allow limitations on how long an implied warranty lasts. Accordingly, the above limitation may not apply to you.

This warranty gives you specific legal rights. You may also have other rights which vary from state to state.

ICON HEALTH & FITNESS, INC., 1500 S. 1000 W., LOGAN, UT 84321-9813

Free Manuals Download Website

<http://myh66.com>

<http://usermanuals.us>

<http://www.somanuals.com>

<http://www.4manuals.cc>

<http://www.manual-lib.com>

<http://www.404manual.com>

<http://www.luxmanual.com>

<http://aubethermostatmanual.com>

Golf course search by state

<http://golfingnear.com>

Email search by domain

<http://emailbydomain.com>

Auto manuals search

<http://auto.somanuals.com>

TV manuals search

<http://tv.somanuals.com>