

NordicTrack[®] PT3

with FREEMOTION TECHNOLOGY

Model No. NTSY9896.0

Serial No. _____

Write the serial number in the space above for future reference.

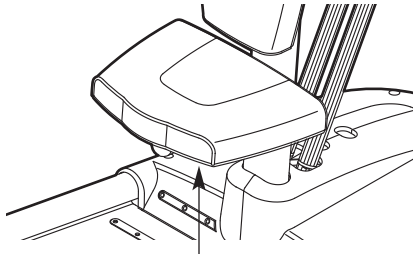

Serial Number Decal (under seat)

QUESTIONS?

As a manufacturer, we are committed to providing complete customer satisfaction. If you have questions, or if a part is damaged or missing, PLEASE CONTACT OUR CUSTOMER SERVICE DEPARTMENT DIRECTLY.

CALL TOLL-FREE:

1-888-825-2588

Mon.–Fri., 6 a.m.–6 p.m. MST

ON THE WEB:

www.nordictrackservice.com

USER'S MANUAL

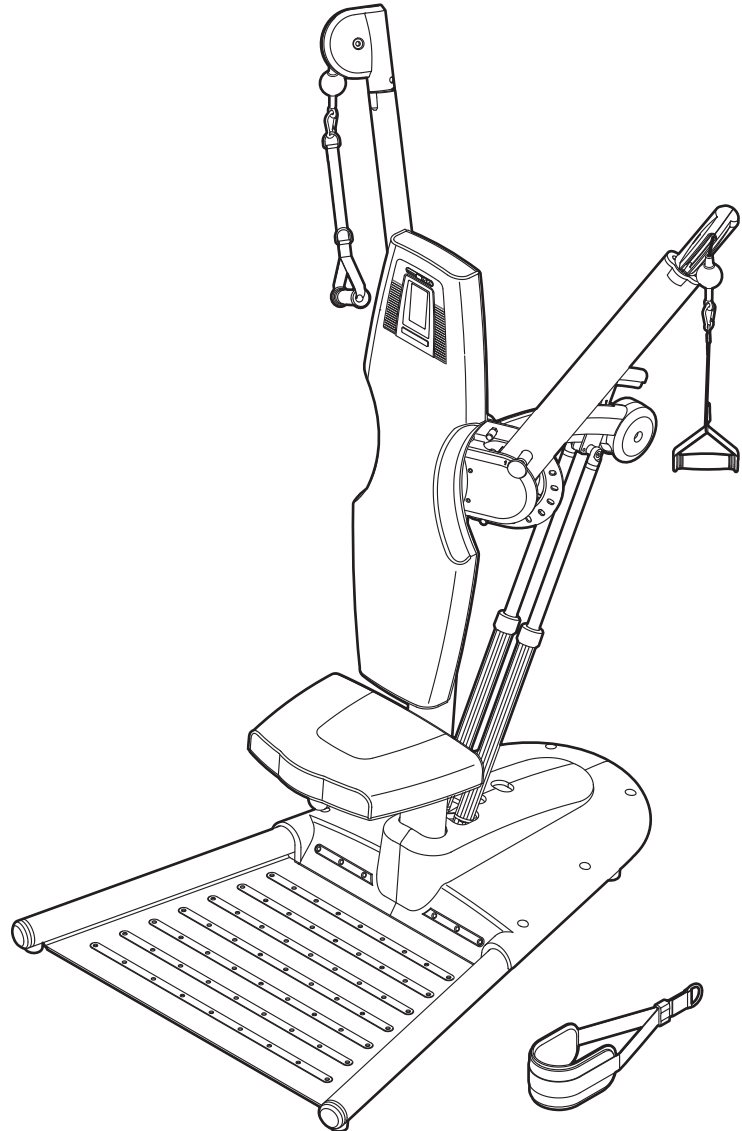

⚠ CAUTION

Read all precautions and instructions in this manual before using this equipment. Save this manual for future reference.



Visit our website at

www.nordictrack.com

new products, prizes,
fitness tips, and much more!

TABLE OF CONTENTS

WARNING DECAL PLACEMENT	2
IMPORTANT PRECAUTIONS	3
BEFORE YOU BEGIN	4
PART IDENTIFICATION CHART	5
ASSEMBLY	6
ADJUSTMENT	8
CONSOLE OPERATION	10
STRENGTH TRAINING GUIDELINES	17
PART LIST	18
EXPLODED DRAWING	19
ORDERING REPLACEMENT PARTS	Back Cover
LIMITED WARRANTY	Back Cover

WARNING DECAL PLACEMENT

The decals shown here have been placed on the resistance system. If a decal is missing or illegible, call the toll-free telephone number on the front cover of this manual and order a free replacement decal. Apply the decal in the location shown.

▲ WARNING

User Weight
Max 300 LBS

Weight Crutch
Max 310 LBS

Leg Developer
Max 150 LBS

Weight Carriage
Max 150 LBS

Chest Fly Per Arm
Max 50 LBS

Product may not offer
all listed exercises.

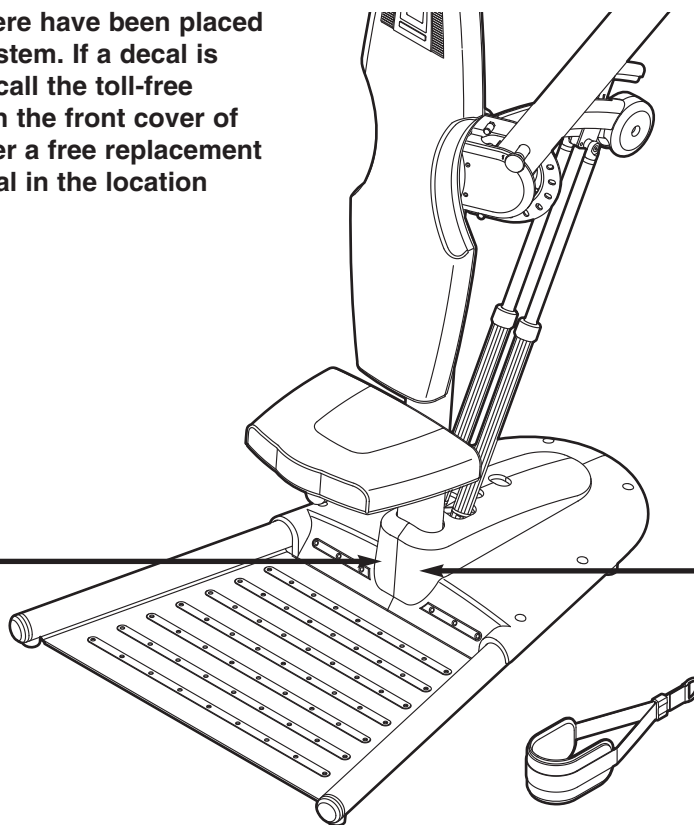

▲ WARNING

- Misuse of this machine may result in serious injury.
- Read user's manual prior to use and follow all warnings and instructions.
- Do not allow children on or around machine.
- Keep body, clothing, and hair free and clear of all moving parts.
- Replace label if damaged, illegible, or removed.

IMPORTANT PRECAUTIONS

⚠️ WARNING: To reduce the risk of serious injury, read the following important precautions before using the resistance system.

1. Read all instructions in this manual and all warnings on the resistance system before using the resistance system. Use the resistance system only as described in this manual.
2. It is the responsibility of the owner to ensure that all users of the resistance system are adequately informed of all precautions.
3. The resistance system is intended for home use only. Do not use the resistance system in any commercial, rental, or institutional setting.
4. Keep the resistance system indoors, away from moisture and dust. Place the resistance system on a level surface, with a mat beneath it to protect the floor or carpet. Make sure that there is enough clearance around the resistance system to mount, dismount, and use it.
5. Inspect and properly tighten all parts regularly. Replace any worn parts immediately.
6. Keep children under age 12 and pets away from the resistance system at all times.
7. Keep hands and feet away from moving parts.
8. Always wear athletic shoes for foot protection while exercising.
9. The resistance system is designed to support a maximum user weight of 300 pounds (136 kg).
10. Make sure that the cables remain on the pulleys at all times. If the cables bind while you are exercising, stop immediately and make sure that the cables are on the pulleys. Replace all cables at least every two years.
11. Always stand on the base plate when performing an exercise that could cause the resistance system to tip.
12. Use the resistance system only with the included resistance. Do not use the resistance system with any other type of weight to add resistance.
13. Always make sure that the pins and knobs are fully engaged before using the resistance system.
14. If you feel pain or dizziness at any time while exercising, stop immediately and begin cooling down.

⚠️ WARNING: Before beginning this or any exercise program, consult your physician. This is especially important for persons over the age of 35 or persons with pre-existing health problems. Read all instructions before using. ICON assumes no responsibility for personal injury or property damage sustained by or through the use of this product.

BEFORE YOU BEGIN

Thank you for selecting the versatile NordicTrack® PT3 WITH FREEMOTION TECHNOLOGY resistance system. The resistance system offers a selection of weight stations designed to develop every major muscle group of the body. Whether your goal is to tone your body, build dramatic muscle size and strength, or improve your cardiovascular system, the resistance system will help you to achieve the specific results you want.

For your benefit, read this manual carefully before using the resistance system. If you have questions

after reading this manual, please see the front cover of this manual. To help us assist you, note the product model number and serial number before contacting us. The model number is NTSY9896.0. The serial number can be found on a decal attached to the resistance system (see the front cover of this manual).

Before reading further, please review the drawing below and familiarize yourself with the parts that are labeled.

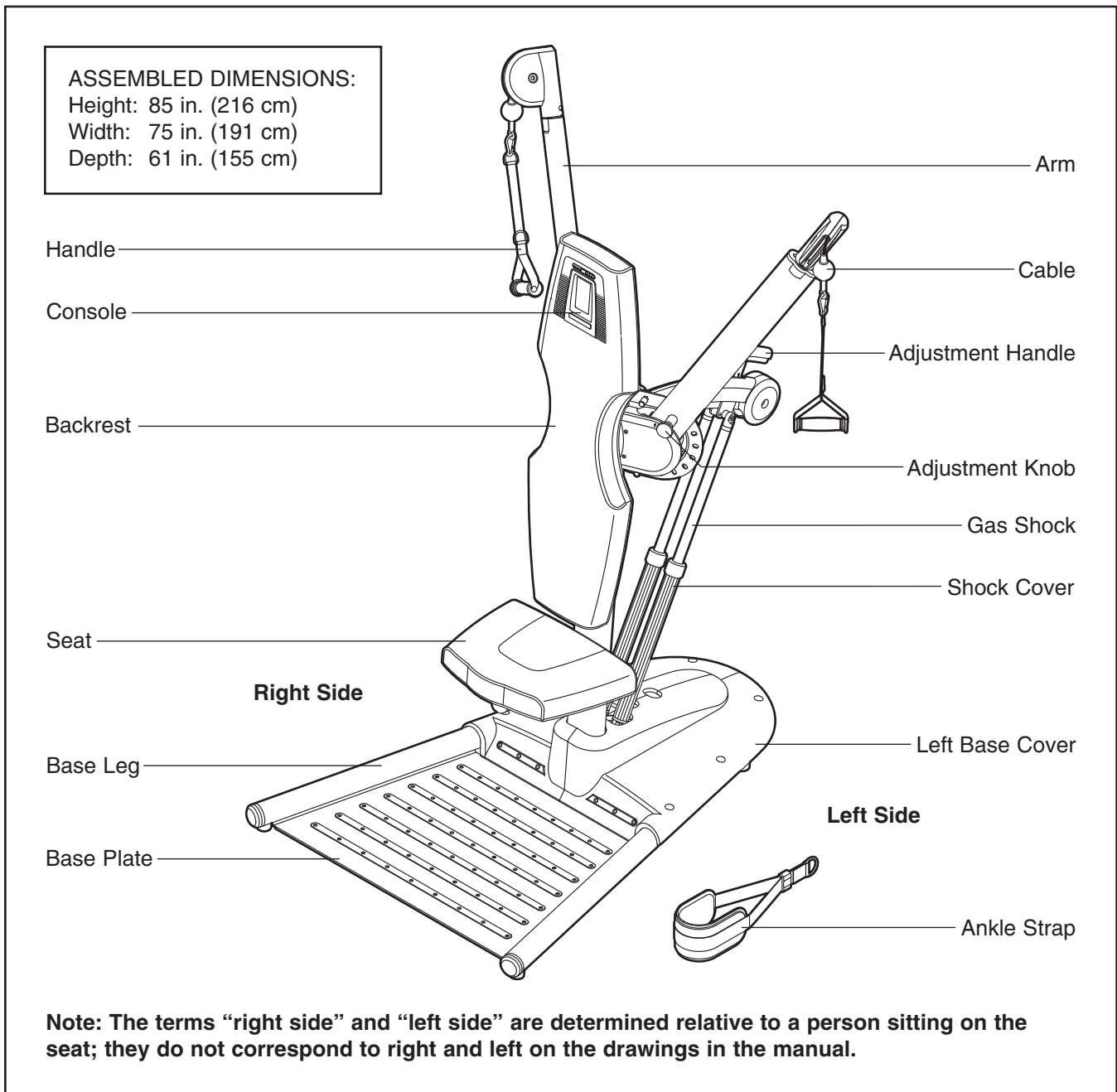

PART IDENTIFICATION CHART

See the drawings below to identify small parts used in assembly. The number in parentheses by each drawing is the key number of the part, from the PART LIST on page 18. **Note: Some small parts may have been preattached. If a part is not in the parts bag, check to see if it has been preattached.**

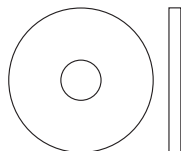

M5 Large Washer (63)

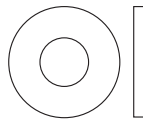

M6 Washer (82)

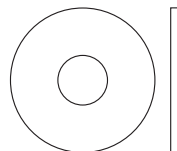

M6 Large Washer (61)

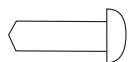

M4 x 12mm Self-tapping Screw (77)

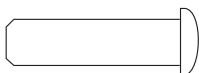

M6 x 20mm Screw (67)

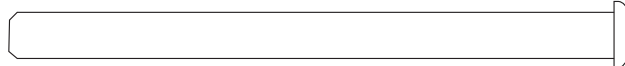

M6 x 80mm Button Screw (68)

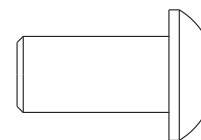

M10 x 20mm Button Screw (59)

ASSEMBLY

Make Assembly Easier



Everything in this manual is designed to ensure that the resistance system can be assembled successfully by almost anyone. By setting aside plenty of time, assembly will go smoothly.

Before beginning assembly, carefully read the following information and instructions:

- Assembly requires two persons.
- Because of its weight and size, the resistance system should be assembled in the location where it will be used. Make sure that there is enough clearance to walk around the resistance system as you assemble it.

- Tighten all parts as you assemble them, unless instructed to do otherwise.
- As you assemble the resistance system, make sure that all parts are oriented as shown in the drawings.
- For help identifying small parts, use the PART IDENTIFICATION CHART on page 5.

The included hex keys  and the following tools (not included) may be required for assembly:

- Two adjustable wrenches 
- One Phillips screwdriver 

Assembly will be more convenient if you have a socket set, a set of open-end or closed-end wrenches, or a set of ratchet wrenches.

1.

Before beginning assembly, make sure that you understand the information in the box above. For help identifying small parts, see the PART IDENTIFICATION CHART on page 5.

See the inset drawing. Remove the indicated packing screws and washers and all packing materials; **do not dispose of the packing materials until assembly is completed.**

Insert the two Base Legs (2) into the Base (1) as far as possible. With the help of a second person, carefully tip the resistance system onto its left or right side.

Attach one of the Base Legs (2) to the Base (1) with two M10 x 20mm Button Screws (59); **do not tighten the Button Screws yet.**

Attach the Left Base Cover (20) to the Base (1) with an M4 x 12mm Self-tapping Screw (77) and an M5 Large Washer (63).

Repeat this step on the other side of the resistance system.

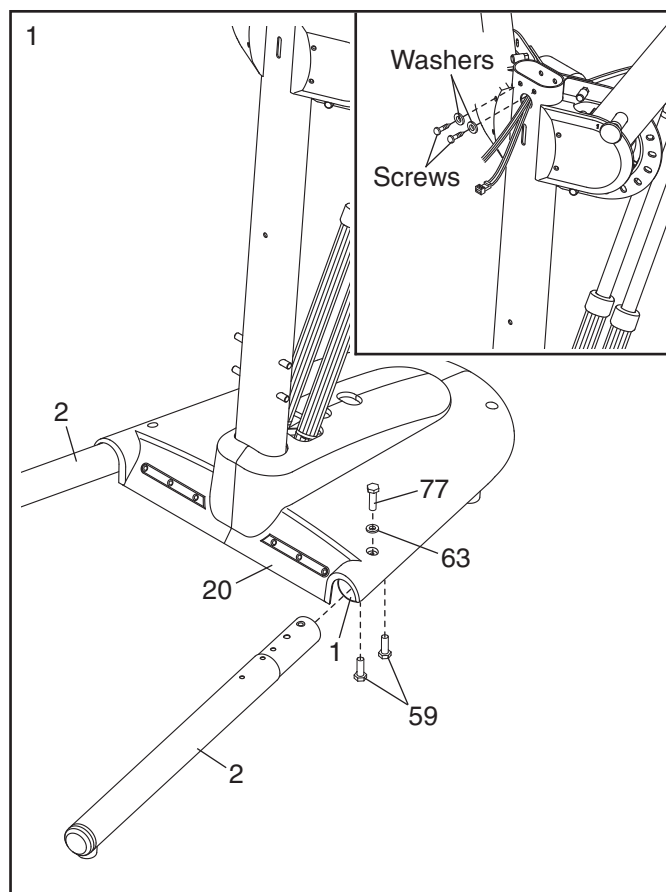

2. Attach the Base Plate (3) to the Base Legs (2) with eight M6 x 20mm Screws (67) and eight M6 Large Washers (61).

See step 1. Tighten the M10 x 20mm Button Screws (59).

Carefully tip the resistance system back into the operating position.

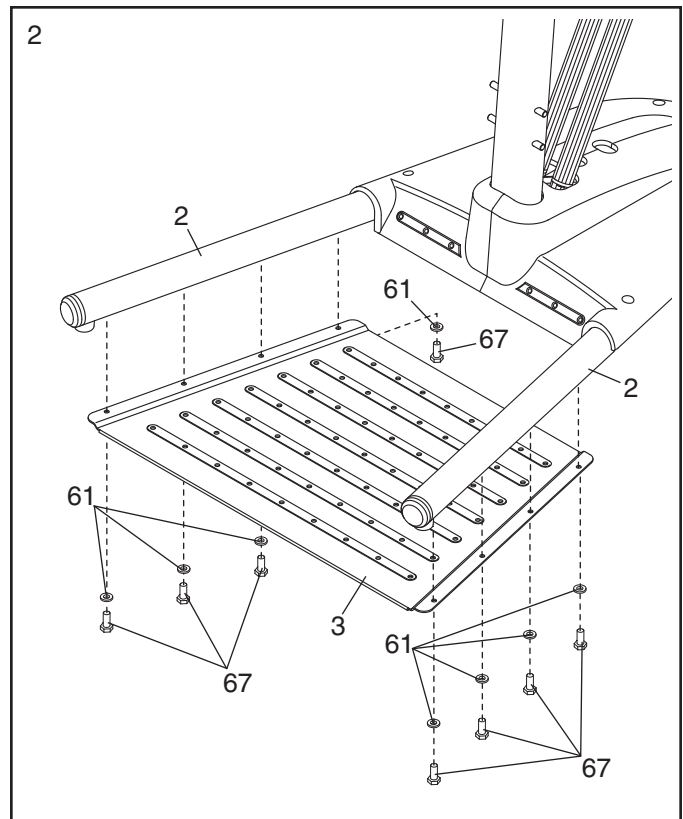

3. Have a second person hold the Backrest (23) near the Base (1). Connect the 4-pin Counter Wire Harness (39) to the 4-pin Console Wire Harness (41). Next, connect the 3-pin Wire Harness (42) to the 3-pin wire harness extending from the Backrest. Carefully push the wire harnesses into the Base.

Attach the Backrest (23) to the Base (1) with three M6 x 80mm Button Screws (68) and three M6 Washers (82).

Press the Upright Cap (33) into the top of the Base (1).

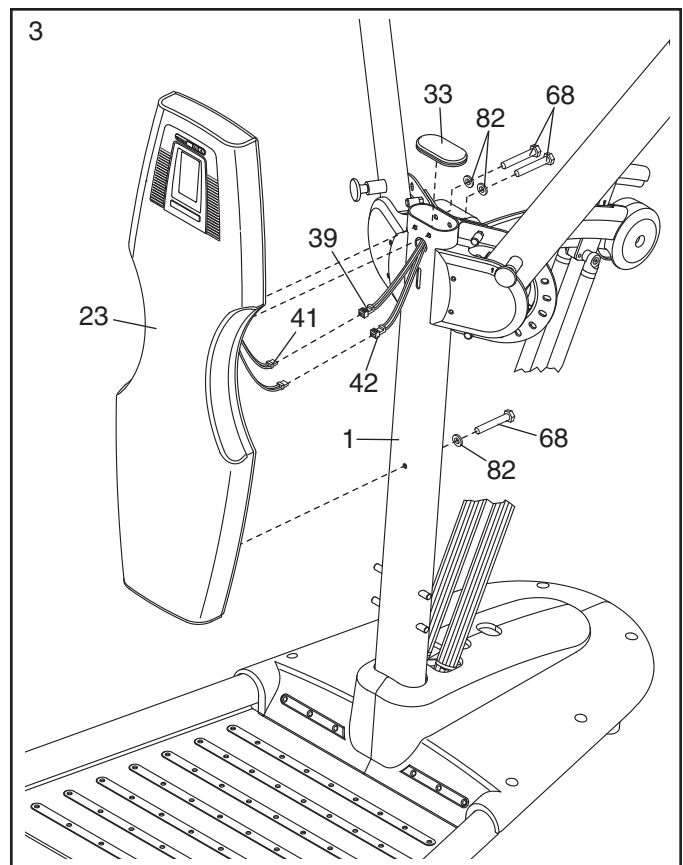

4. **Make sure that all parts are properly tightened.** The use of the remaining parts will be explained in ADJUSTMENT, beginning on the following page.

ADJUSTMENT

This section explains how to adjust the resistance system. Properly tighten all parts each time you use the resistance system. Replace any worn parts immediately. To clean the resistance system, use a damp cloth and a mild, non-abrasive detergent; **do not use solvents to clean the resistance system.**

ADJUSTING THE SEAT

The Seat (24) can be attached at either of two heights. To raise or lower the Seat (24), lift it off the pins on the Base (1) and set it on a different set of pins. For exercises that do not require the Seat, remove the Seat and set it out of the way.

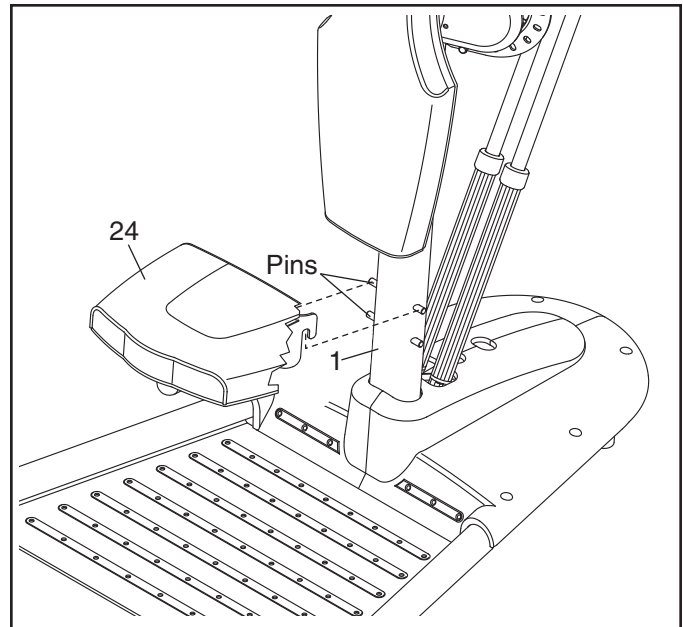

ATTACHING THE HANDLES

To attach a Handle (37), first attach a Weight Clip (49) to the Cable (38). Then, attach the Handle to the Weight Clip. Attach the other Handle (37) in the same way.

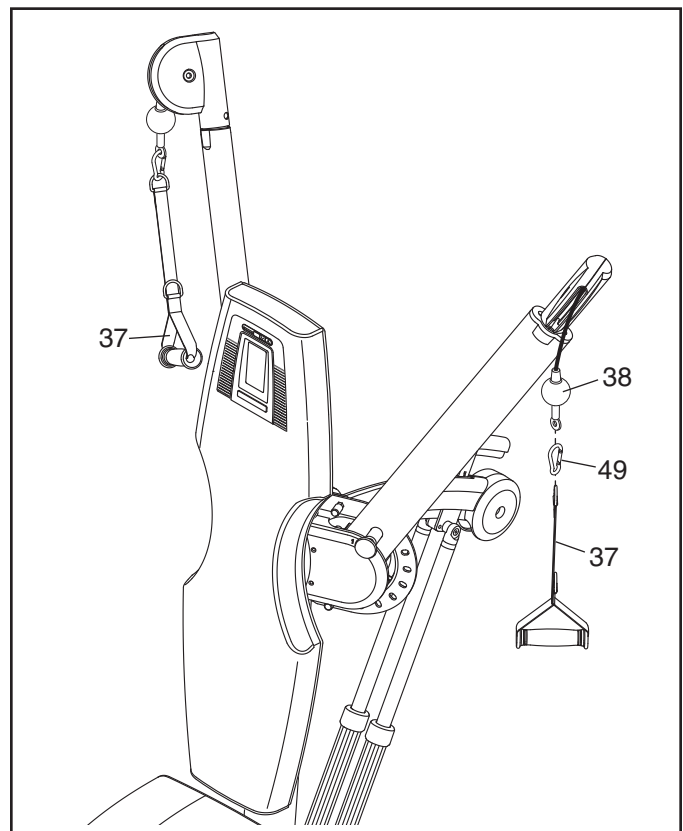

ADJUSTING THE RESISTANCE

To increase the resistance, first squeeze the Adjustment Handle (12). Next, lift the end of the Adjustment Handle and move it away from the Backrest (23). When the Adjustment Handle is in the desired position, release it. **Push the Adjustment Handle forward or backward slightly to make sure that it is fully engaged.**

To decrease the resistance, first squeeze the Adjustment Handle (12). Next, push down on the end of the Adjustment Handle and move it toward the Backrest (23). When the Adjustment Handle is in the desired position, release it. **Push the Adjustment Handle forward or backward slightly to make sure that it is fully engaged.**

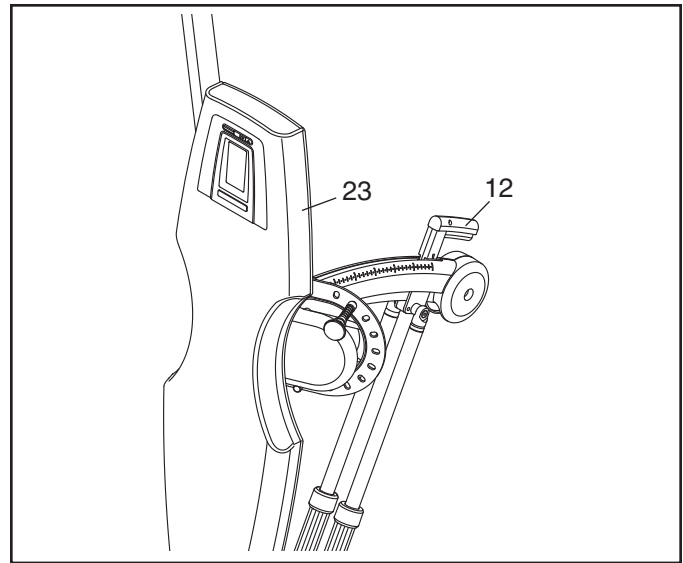

ADJUSTING THE ARMS

To adjust the Left or Right Arm (6 or 7), first **hold the Arm with one hand** and pull the Adjustment Knob (34). Move the Arm to the desired position, and reengage the Adjustment Knob into the Adjustment Plate (11).

WARNING: Make sure that the Adjustment Knob (34) is fully engaged in the Adjustment Plate (11) before you exercise.

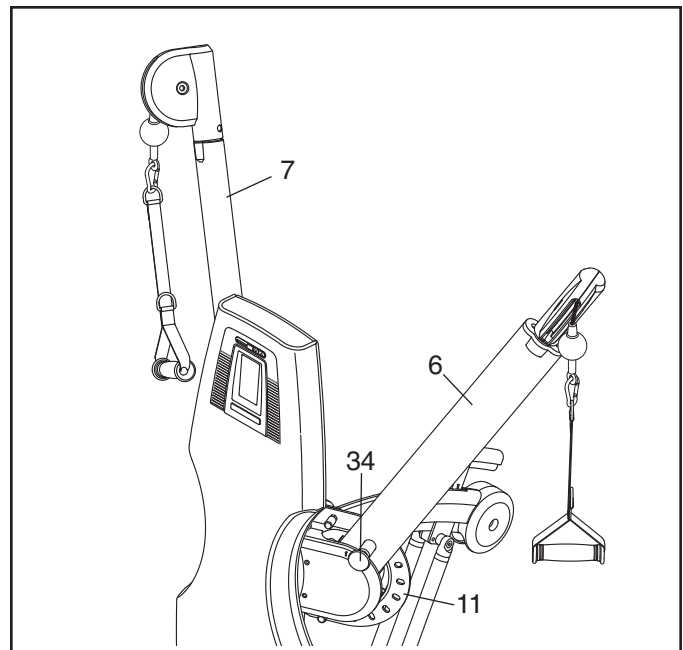

TIGHTENING THE CABLE

To tighten the Cable (38), first move the Left Arm (6) and the Right Arm (not shown) to the highest position. Next, adjust the resistance to 310 pounds. Locate the end of the Cable that has cable clamps, and pull that end of the Cable until you feel resistance. Measure the distance between the cable cover and the Left Arm.

Next, adjust the resistance to the minimum setting. Have a second person pull the Cable (38) and hold it. Slide the cable cover off the cable clamps, and loosen the two screws in the cable clamps. Next, pull the Cable through the indicated link and the cable clamps to shorten the Cable by the measured amount. Then, tighten the two screws and slide the cable cover onto the cable clamps.

WARNING: Fully tighten the two screws before you exercise.

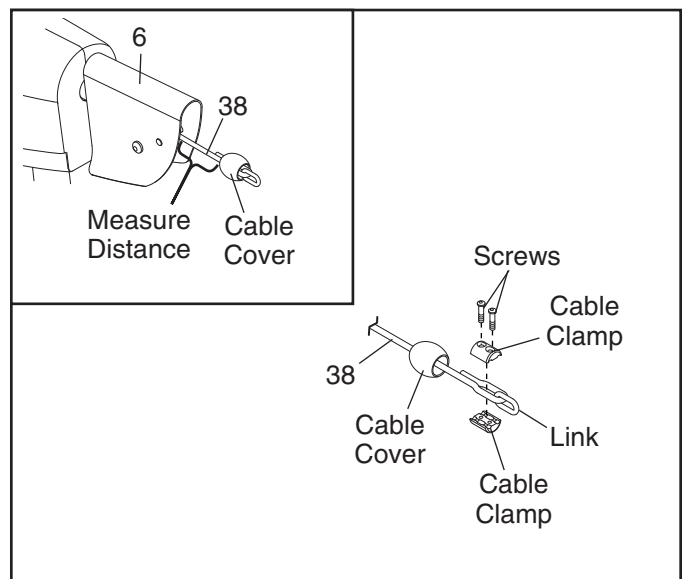

CONSOLE OPERATION

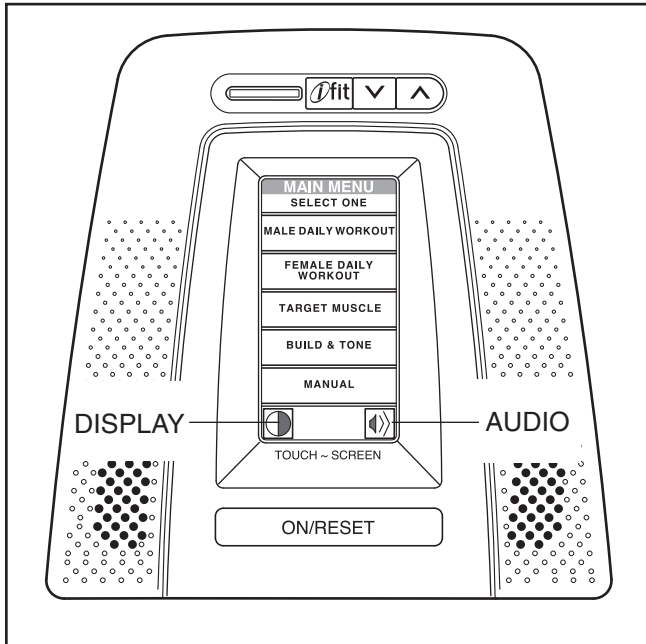

FEATURES OF THE CONSOLE

The revolutionary console offers an array of features designed to make your workouts more effective.

When you use the manual mode of the console, you can enter the numbers of sets and reps that you plan to complete and set a length of time to rest between sets. As you perform strength exercises, the console will track your progress according to the settings you enter.

The console also features two interactive workout routines, each with five daily workouts designed to help you build and tone your muscles. During each daily workout, the voice of a personal trainer will prompt you to perform a variety of strength exercises while guiding you through an effective strength-training workout.

The console also offers five target muscle workouts that help you work specific areas of the body. The voice of a personal trainer will guide you through each target muscle exercise.

In addition, the console features four build and tone workouts for the upper and lower body. During each build and tone workout, the voice of a personal trainer will prompt you to perform a series of strength exercises.

The console also features the new iFIT Interactive Workout System. The iFIT Interactive Workout System enables the console to accept iFIT Cards containing workout programs designed to help you achieve specific fitness goals. One demo iFIT Card is included. Additional iFIT Cards are available separately. **To purchase iFIT Cards, go to www.iFIT.com or call the telephone number on the front cover of this manual. iFIT Cards are also available at select stores.**

To use the manual mode of the console, follow the steps beginning on page 11. **To use a daily workout**, see page 12. **To use a target muscle workout**, see page 13. **To use a build and tone workout**, see page 14. **To use an iFIT workout**, see page 15.

HOW TO PLUG IN THE TRANSFORMER

Plug the indicated end of the transformer into the jack in the resistance system. Plug the other end of the transformer into a 120-volt outlet. The console display will light and a tone will sound; the console will then be ready for use.

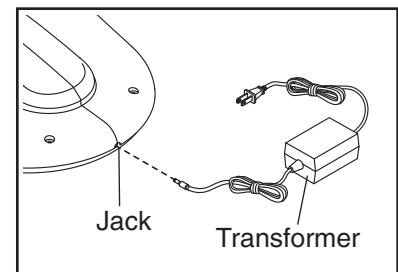

HOW TO USE THE MANUAL MODE

Note: If there is a sheet of clear plastic on the face of the console, remove the plastic.

1. Touch the screen or press the ON/RESET button to turn on the console.

When you turn on the console, the display will light. A tone will then sound and the main menu will appear on the screen (see the drawing on page 10).

If desired, touch the AUDIO button in the lower right corner of the screen and see HOW TO ADJUST THE AUDIO SETTINGS on page 16 to adjust the audio settings.

If desired, touch the DISPLAY button in the lower left corner of the screen and see HOW TO ADJUST THE DISPLAY SETTINGS on page 16 to adjust the display settings.

2. Select the manual mode.

When the main menu appears on the screen, touch the MANUAL button to select the manual mode.

3. Enter workout settings.

After you select the manual mode, the manual mode screen will appear. You can now enter the following workout settings:

Sets—Touch the SETS UP/DOWN buttons to enter the desired number of sets. You can enter 1 to 25 sets.

Reps—Touch the REPS UP/DOWN buttons to enter the desired number of reps (repetitions). You can enter 1 to 25 reps.

Rest—Touch the REST UP/DOWN buttons to adjust the rest period between sets. The setting will change in increments of 5 seconds. The rest period can be from 5 seconds to 4 minutes long.

Touch the OK button to save your settings and continue with the workout. If desired, touch the BACK button to return to the main menu.

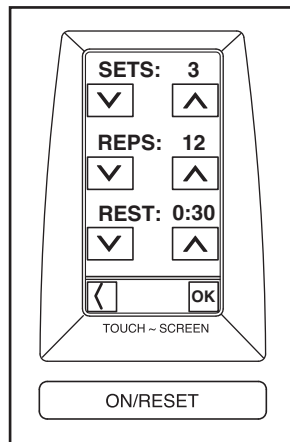

4. Perform exercises.

Perform repetitions of the exercise of your choice with a slow, steady motion. The voice of the console and the display will count the repetitions as you perform them. At the end of a set, rest for the amount of time shown in the display. Then, resume performing repetitions and sets as indicated in the display.

If desired, touch the BACK button to return to the manual mode screen. Touch the MAIN MENU button to return to the main menu.

5. Follow your progress with the display.

As you exercise, the upper section of the display will show the current set and the total number of sets to be performed.

The lower section of the display will show the current rep and the total number of reps to be performed in each set. **Note: The cables must move at least 12 inches (30 cm) for repetitions to be counted by the console.**

The lower left section of the display will also show the rest period and count down the time remaining in the rest period.

6. Continue entering workout settings and performing exercises as desired.

When the workout is finished, the manual mode screen will appear. See steps 3 and 4 above and continue entering workout settings and performing exercises as desired.

When you are finished exercising in the manual mode, touch the BACK button or press the ON/RESET button to return to the main menu.

7. When you are finished exercising, the console will turn off automatically.

If the cables do not move, the screen is not touched, and the buttons are not pressed for a few minutes, the console will turn off and the display will be reset.

Note: When the demo mode is turned on (see HOW TO ADJUST THE DISPLAY SETTINGS on page 16), the console will enter the demo mode after sitting idle for five minutes. The screen will then show an animation. To exit the demo mode, touch the screen or press the ON/RESET button.

HOW TO USE A DAILY WORKOUT

1. Touch the screen or press the ON/RESET button to turn on the console.

See step 1 on page 11.

2. Select a male or female workout routine.

Touch the MALE DAILY WORKOUT button to select a workout routine designed for men. Touch the FEMALE DAILY WORKOUT button to select a workout routine designed for women.

3. Select a daily workout.

Each workout routine consists of five different workouts to be performed on different days of the week. To select a daily workout, touch the name of the desired workout on the screen.

If desired, touch the BACK button or the MAIN MENU button to return to the main menu. Touch the AUDIO button to change the audio settings.

Note: The voice of a personal trainer will guide you through the workout. To adjust the volume or select an audio setting for your personal trainer, touch the AUDIO button and see HOW TO ADJUST THE AUDIO SETTINGS on page 16. During the workout, you can touch the AUDIO button and change the audio settings any time the AUDIO button appears on a screen.

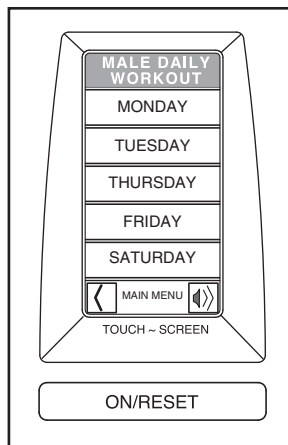

4. Begin the daily workout.

When you select a daily workout, the voice of a personal trainer will begin explaining the first exercise. The name of the exercise and an animation of the exercise will then appear on the screen. Touch the READY button at any time during the explanation to begin the exercise.

Perform repetitions of the exercise as described by the personal trainer. Exercise with a slow, steady motion. The personal trainer and the display will count the repetitions as you perform them. At the end of a set, rest for the amount of time shown in the display. Then, resume performing repetitions and sets as indicated in the display.

If desired, touch the BACK button to return to the exercise explanation. Touch the FORWARD button to skip to the next exercise. Touch the MAIN MENU button to return to the main menu.

5. Continue the daily workout.

When you have completed the first exercise, the personal trainer will explain the next exercise in the workout and then guide you through the next exercise.

The program will continue until the last exercise in the workout is completed. The words WORKOUT COMPLETE will then appear on the screen.

If desired, press the ON/RESET button to return to the main menu.

6. Follow your progress with the display.

See step 5 on page 11.

7. When you are finished exercising, the console will turn off automatically.

See step 7 on page 11.

HOW TO USE A TARGET MUSCLE WORKOUT

1. Touch the screen or press the ON/RESET button to turn on the console.

See step 1 on page 11.

2. Access the target muscle workout menu.

Touch the TARGET MUSCLE button to access the target muscle workout menu.

3. Select the desired target muscle workout.

The target muscle workout menu allows you to choose among five target muscle workouts. To select a target muscle workout, touch the name of the desired workout on the screen.

If desired, touch the BACK button or the MAIN MENU button to return to the main menu. Touch the AUDIO button to change the audio settings.

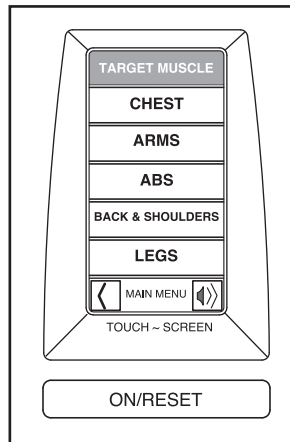

Note: The voice of a personal trainer will guide you through the workout. To adjust the volume or select an audio setting for your personal trainer, touch the AUDIO button and see HOW TO ADJUST THE AUDIO SETTINGS on page 16. During the workout, you can touch the AUDIO button and change the audio settings any time the AUDIO button appears on a screen.

4. Select the desired target exercise.

When you select a target muscle workout, a target exercise menu will appear on the screen. To select a target exercise, touch the name of the desired target exercise on the screen. If necessary, touch the SCROLL UP/DOWN buttons or press the up and down buttons next to the iFIT slot to view all the target exercises on the menu.

If desired, touch the BACK button to return to the target muscle workout menu. Touch the MAIN MENU button to return to the main menu. Touch the AUDIO button to change the audio settings.

5. Perform the target exercise.

When you select a target exercise, the voice of a personal trainer will begin explaining the exercise. The name of the exercise and an animation of the exercise will then appear on the screen. Touch the READY button at any time during the explanation to begin the exercise. If desired, touch the BACK button to return to the target exercise menu.

Perform repetitions of the exercise as described by the personal trainer. Exercise with a slow, steady motion. The personal trainer and the display will count the repetitions as you perform them. At the end of a set, rest for the amount of time shown in the display. Then, resume performing repetitions and sets as indicated in the display.

If desired, touch the BACK button to return to the exercise explanation. Touch the FORWARD button to return to the target exercise menu. Touch the MAIN MENU button to return to the main menu.

6. Continue the target muscle workout.

When you have performed a target exercise, the name of that exercise will appear crossed out on the target exercise menu.

Continue selecting and performing target exercises as described in steps 4 and 5 above.

When you have performed all the target exercises in a target muscle workout, the words WORKOUT COMPLETE will appear on the screen.

If desired, press the ON/RESET button to return to the main menu.

Note: If you touch the BACK button or the MAIN MENU button to return to the target muscle workout menu or the main menu at any time during a target muscle workout, the console will be reset and the record of target exercises you have completed will be lost.

7. Follow your progress with the display.

See step 5 on page 11.

8. When you are finished exercising, the console will turn off automatically.

See step 7 on page 11.

HOW TO USE A BUILD AND TONE WORKOUT

1. Touch the screen or press the ON/RESET button to turn on the console.

See step 1 on page 11.

2. Access the build and tone workout menu.

Touch the BUILD & TONE button to access the build and tone workout menu.

3. Select the desired build and tone workout.

The build and tone workout menu allows you to choose among two upper body and two lower body workouts. To select a build and tone workout, touch the name of the desired workout on the screen.

If desired, touch the BACK button or the MAIN MENU button to return to the main menu. Touch the AUDIO button to change the audio settings.

Note: The voice of a personal trainer will guide you through the workout. To adjust the volume or select an audio setting for your personal trainer, touch the AUDIO button and see HOW TO ADJUST THE AUDIO SETTINGS on page 16. During the workout, you can touch the AUDIO button and change the audio settings any time the AUDIO button appears on a screen.

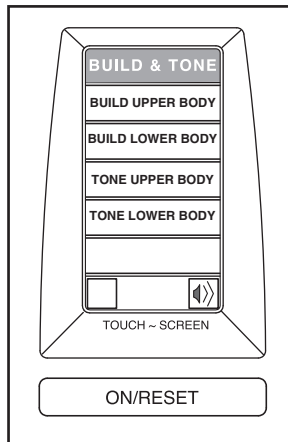

4. Begin the build and tone workout.

When you select a build and tone workout, the voice of a personal trainer will begin explaining the first exercise. The name of the exercise and an animation of the exercise will then appear on the screen. Touch the READY button at any time during the explanation to begin the exercise.

Perform repetitions of the exercise as described by the personal trainer. Exercise with a slow, steady motion. The personal trainer and the display will count the repetitions as you perform them. At the end of a set, rest for the amount of time shown in the display. Then, resume performing repetitions and sets as indicated in the display.

If desired, touch the BACK button to return to the exercise explanation. Touch the FORWARD button to skip to the next exercise. Touch the MAIN MENU button to return to the main menu.

5. Continue the build and tone workout.

When you have completed the first exercise, the personal trainer will explain the next exercise in the workout and then guide you through the exercise.

The program will continue in this way until the last exercise in the workout is completed. The words WORKOUT COMPLETE will then appear on the screen.

6. Follow your progress with the display.

See step 5 on page 11.

7. When you are finished exercising, the console will turn off automatically.

See step 7 on page 11.

HOW TO USE AN IFIT WORKOUT

1. **Touch the screen or press the ON/RESET button to turn on the console.**

See step 1 on page 11.

2. **Insert an iFIT Card and select a program.**

To use an iFIT workout, insert an iFIT Card into the iFIT slot; make sure that the iFIT Card is oriented so the metal contacts are face-down and are facing the slot. When the iFIT Card is properly inserted, the indicator next to the slot will light and an iFIT menu will appear on the screen.

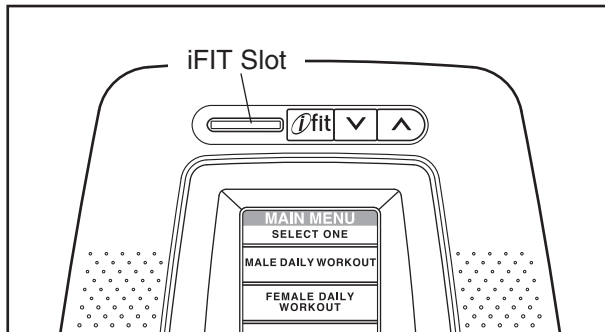

Next, select the desired workout on the iFIT Card by touching the name of the workout on the screen.

A moment after you select a workout, the voice of a personal trainer will begin guiding you through your workout. iFIT workouts function in the same way as build and tone workouts. To use the iFIT workout, see steps 3 to 7 on page 14.

HOW TO ADJUST THE DISPLAY SETTINGS

When you touch the DISPLAY button on a screen, you will access the display settings screen. The display settings screen allows you to make the following display adjustments:

LCD Contrast—To adjust the LCD contrast for the screen, touch the LCD CONTRAST UP/DOWN buttons. To restore the default contrast setting, touch the DEFAULT button.

Note: It is possible to adjust the contrast beyond viewable limits. If this occurs, simply touch the DEFAULT button and restore the default contrast setting.

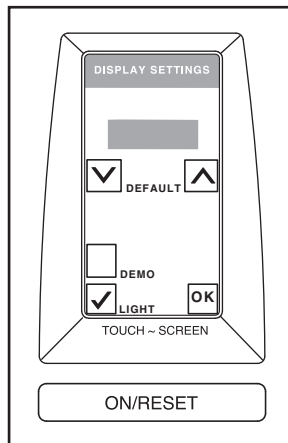

Demo Mode—Touch the DEMO MODE check box to toggle the demo mode on and off. The demo mode is turned on when a check mark appears in the check box.

When the demo mode is turned on, the console will enter the demo mode after sitting idle for five minutes. The screen will then show an animation. To exit the demo mode, touch the screen or press the ON/RESET button.

LCD Backlight—Touch the LIGHT check box to toggle the LCD backlight on and off. The LCD backlight is turned on when a check mark appears in the check box.

Touch the OK button to save the LCD contrast and demo mode settings and exit the display settings screen. Note: The LCD backlight setting will not be saved in memory for the next time you turn on the console.

HOW TO ADJUST THE AUDIO SETTINGS

When you touch the AUDIO button on a screen, you will access the audio settings screen. The audio settings screen allows you to make the following audio adjustments:

Personal Trainer Audio Setting—Touch the PERSONAL TRAINER check box to toggle the voice of the personal trainer on and off.

When a check mark appears in the PERSONAL TRAINER check box, the voice of the personal trainer will guide you through a workout with basic instructions.

When no check mark appears in the PERSONAL TRAINER check box, the voice of the personal trainer will be turned off.

Full Instructions Audio Setting—Touch the FULL INSTRUCTIONS check box to toggle the detailed personal trainer instructions on and off.

When check marks appear in both the FULL INSTRUCTIONS and PERSONAL TRAINER check boxes, the voice of the personal trainer will guide you through a workout with detailed instructions.

Volume—To adjust the volume level, touch the volume bar to move the indicator to the desired volume level.

Touch the OK button to save the audio settings and exit the audio settings screen.

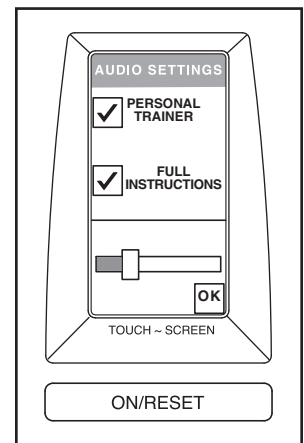

STRENGTH TRAINING GUIDELINES

PERSONALIZING YOUR EXERCISE PROGRAM

Determining the proper length of time for each workout and the numbers of repetitions or sets to complete is an individual matter. Avoid overdoing it during the first few months of your exercise program. Progress at your own pace, and be sensitive to your body's signals. If you experience pain or dizziness while exercising, stop immediately and begin cooling down. Find out what is wrong before continuing.

Remember that adequate rest and a proper diet are important factors in any exercise program.

Warming Up—Begin each workout with 5 to 10 minutes of stretching and light exercise to warm up. Warming up prepares your body for more strenuous exercise by increasing circulation, raising your body temperature, and delivering more oxygen to your muscles.

Working Out—Each workout should include 6 to 10 different exercises. Select exercises for every major muscle group, emphasizing areas that you want to develop most. To give balance and variety to your workouts, vary the exercises from workout to workout.

Schedule your workouts for the time of day when your energy level is the highest. Each workout should be followed by at least one day of rest. Once you find the schedule that is right for you, stick with it.

Exercise Form—Maintaining proper form is an essential part of an effective exercise program. This requires moving through the full range of motion for each exercise, and moving only the appropriate parts of the body. Exercising in an uncontrolled manner will leave you feeling exhausted.

The repetitions in each set should be performed smoothly and without pausing. The exertion stage of each repetition should last about half as long as the return stage. Proper breathing is important. Exhale during the exertion stage of each repetition and inhale during the return stroke. Never hold your breath.

Cooling Down—End each workout with 5 to 10 minutes of stretching. Include stretches for both your arms and legs. Ease into each stretch gradually and go only as far as you can without strain. Move slowly as you stretch and do not bounce. Stretching at the end of each workout is an effective way to increase flexibility.

Staying Motivated—For motivation, keep a record of each workout. List the date, the exercises performed, the resistance used, and the numbers of sets and repetitions completed. Record your weight and key body measurements at the end of every month.

THE BASIC TYPES OF STRENGTH WORKOUTS

Note: See the accompanying DVD to learn the correct form for a variety of exercises that can be performed with the resistance system.

Muscle Building—To increase the size and strength of your muscles, push them close to their maximum capacity. Your muscles will continually adapt and grow as you progressively increase the intensity of your exercise.

Begin with 3 sets of 8 repetitions for each exercise you perform. Rest for 3 minutes after each set. When you can complete 3 sets of 12 repetitions without difficulty, increase the amount of resistance.

Toning—You can tone your muscles by pushing them to a moderate percentage of their capacity. Select a moderate amount of resistance and increase the number of repetitions in each set. Complete as many sets of 15 to 20 repetitions as possible without discomfort. Rest for 1 minute after each set. Work your muscles by completing more sets rather than by using high amounts of resistance.

Weight Loss—To lose weight, use a low amount of resistance and increase the number of repetitions in each set. Exercise for 20 to 30 minutes, resting for a maximum of 30 seconds between sets.

Cross Training—Cross training is an efficient way to get a complete and well-balanced fitness program. An example of a balanced program follows:

- Plan strength training workouts on Monday, Wednesday, and Friday.
- Plan 20 to 30 minutes of aerobic exercise, such as running on a treadmill or using an exercise cycle, on Tuesday and Thursday.
- Rest from both strength training and aerobic exercise for at least one full day each week to give your body time to regenerate.

The combination of strength training and aerobic exercise will reshape and strengthen your body and develop your heart and lungs.

PART LIST—Model No. NTSY9896.0

R0307A

Key No.	Qty.	Description	Key No.	Qty.	Description
1	1	Base	48	2	Arm Cap
2	2	Base Leg	49	2	Weight Clip
3	1	Base Plate	50	1	Left Retainer Clip
4	1	16mm Spacer	51	1	Right Rear Cover
5	1	Seat Frame	52	1	Right Front Cover
6	1	Left Arm	53	1	Backrest Plate
7	1	Right Arm	54	1	Seat Plate
8	1	Adjustment Arm	55	1	Counter Bracket
9	2	Gas Shock	56	2	M10 x 88mm Button Bolt
10	2	Shock Cover	57	1	M10 x 67mm Button Bolt
11	2	Adjustment Plate	58	4	M10 x 52mm Button Bolt
12	1	Adjustment Handle	59	8	M10 x 20mm Button Screw
13	1	Handle Bracket	60	1	M10 x 95mm Bolt
14	1	Left Handle Cover	61	10	M6 Large Washer
15	1	Right Handle Cover	62	1	M10 x 71mm Bolt
16	1	Left Adjustment Arm Cover	63	6	M5 Large Washer
17	1	Right Adjustment Arm Cover	64	1	Right Retainer Clip
18	1	Left Rear Cover	65	4	M10 x 47mm Bolt
19	1	Left Front Cover	66	1	M5 x 55mm Bolt
20	1	Left Base Cover	67	8	M6 x 20mm Screw
21	1	Right Base Cover	68	3	M6 x 80mm Button Screw
22	1	Console	69	2	M6 x 35mm Button Bolt
23	1	Backrest	70	2	M6 x 18mm Button Bolt
24	1	Seat	71	1	M4 x 20mm Self-tapping Screw
25	1	Seat Frame Cap	72	4	M6 x 25mm Screw
26	2	64mm Round Inner Cap	73	4	M6 x 50mm Self-tapping Screw
27	4	Base Foot	74	4	M6 x 40mm Self-tapping Screw
28	2	Left Pulley Cover	75	6	M4 x 25mm Self-tapping Screw
29	2	Right Pulley Cover	76	2	M4 x 22mm Self-tapping Screw
30	2	115mm Pulley	77	13	M4 x 12mm Self-tapping Screw
31	7	90mm Pulley	78	4	M5 x 30mm Self-tapping Screw
32	4	70mm Pulley	79	4	M5 x 20mm Self-tapping Screw
33	1	Upright Cap	80	4	Large Washer
34	2	Adjustment Knob	81	6	M10 Washer
35	1	Magnet	82	3	M6 Washer
36	1	Ankle Strap	83	2	M5 Washer
37	2	Handle	84	5	M4 Washer
38	1	Cable	85	13	M10 Nylon Locknut
39	1	4-pin Counter Wire Harness	86	2	M6 Nylon Locknut
40	1	Transformer	87	1	M5 Nylon Locknut
41	1	4-pin Console Wire Harness	88	4	Snap Ring
42	1	3-pin Wire Harness	89	2	M3 x 8mm Self-tapping Screw
43	4	Arm Bushing	*	-	User's Manual
44	4	Pulley Bushing	*	-	Exercise Guide
45	4	Barrel Nut	*	-	Hex Key
46	2	Pivot Pulley Bearing	*	-	Grease Packet
47	1	Handle Spring			

Note: Specifications are subject to change without notice. See the back cover of this manual for information about ordering replacement parts. *These parts are not illustrated.

EXPLODED DRAWING—Model No. NTSY9896.0

R0307A

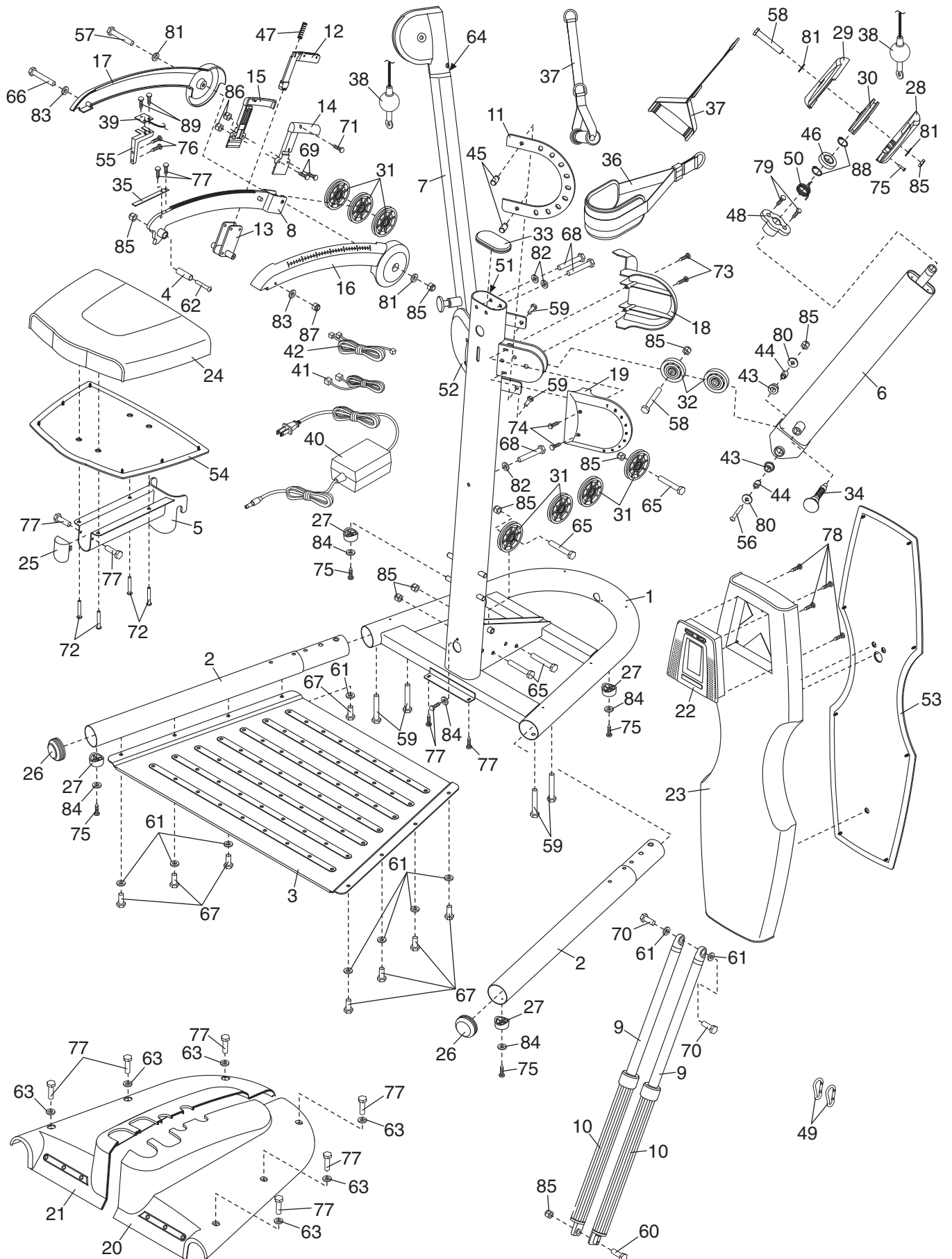

ORDERING REPLACEMENT PARTS

To order replacement parts, please see the front cover of this manual. To help us assist you, be prepared to give the following information:

- the MODEL NUMBER of the product (NTSY9896.0)
- the NAME of the product (NordicTrack PT3 WITH FREEMOTION TECHNOLOGY resistance system)
- the SERIAL NUMBER of the product (see the front cover of this manual)
- the KEY NUMBER and DESCRIPTION of the part(s) (see the PART LIST and the EXPLODED DRAWING on pages 18 and 19)

LIMITED WARRANTY

WHAT IS COVERED—The entire NordicTrack resistance system (“Product”) is warranted to be free of all defects in material and workmanship.

WHO IS COVERED—The original purchaser or any person receiving the Product as a gift from the original purchaser.

HOW LONG IS IT COVERED—ICON Health & Fitness, Inc. (“ICON”), warrants the frame for five years after the date of purchase. ICON warrants all other parts for one year. Labor is covered for one year.

WHAT WE DO TO CORRECT COVERED DEFECTS—We will ship to you, without charge, any replacement part or component, providing the repairs are authorized by ICON first and are performed by an ICON trained and authorized service provider, or, at our option, we will replace the Product.

WHAT IS NOT COVERED—Any failures or damage caused by unauthorized service, misuse, accident, negligence, improper assembly or installation, alterations, modifications without our written authorization or by failure on your part to use, operate, and maintain as set out in your User’s Manual (“Manual”).

WHAT YOU MUST DO—Always retain proof of purchase, such as your bill of sale; store, operate, and maintain the Product as specified in the Manual; notify our Customer Service Department of any defect within 10 days after discovery of the defect; as instructed, return any defected part for replacement or, if necessary, the entire product, for repair.

USER’S MANUAL—It is VERY IMPORTANT THAT YOU READ THE MANUAL before operating the Product. Remember to do the periodic maintenance requirements specified in the Manual to assure proper operation and your continued satisfaction.

HOW TO GET PARTS AND SERVICE—Simply call our Customer Service Department at 1-888-825-2588 and tell them your name and address and the serial number of your Product. They will tell you how to get a part replaced, or if necessary, arrange for service where your Product is located or advise you how to ship the Product for service. Before shipping, always obtain a Return Authorization Number (RA No.) from our Customer Service Department; securely pack your Product (save the original shipping carton if possible); put the RA No. on the outside of the carton and insure the product. Include a letter explaining the product or problem and a copy of your proof of purchase if you believe the service is covered by warranty.

ICON is not responsible or liable for indirect, special or consequential damages arising out of or in connection with the use or performance of the product or damages with respect to any economic loss, loss of property, loss of revenues or profits, loss of enjoyment or use, costs of removal, installation or other consequential damages of whatsoever nature. Some states do not allow the exclusion or limitation of incidental or consequential damages. Accordingly, the above limitation may not apply to you.

The warranty extended hereunder is in lieu of any and all other warranties and any implied warranties of merchantability or fitness for a particular purpose is limited in its scope and duration to the terms set forth herein. Some states do not allow limitations on how long an implied warranty lasts. Accordingly, the above limitation may not apply to you.

No one is authorized to change, modify or extend the terms of this limited warranty. This warranty gives you specific legal rights and you may have other rights which vary from state to state.

ICON HEALTH & FITNESS, INC., 1500 S. 1000 W., LOGAN, UT 84321-9813

Free Manuals Download Website

<http://myh66.com>

<http://usermanuals.us>

<http://www.somanuals.com>

<http://www.4manuals.cc>

<http://www.manual-lib.com>

<http://www.404manual.com>

<http://www.luxmanual.com>

<http://aubethermostatmanual.com>

Golf course search by state

<http://golfingnear.com>

Email search by domain

<http://emailbydomain.com>

Auto manuals search

<http://auto.somanuals.com>

TV manuals search

<http://tv.somanuals.com>