



# NH Series<sup>™</sup>

## **NHTC / NHPC ELECTRODE STEAM HUMIDIFIER**

### **Installation Manual**

## PROPRIETARY NOTICE

This document and the information disclosed herein are proprietary data of WALTER MEIER LTD. Neither this document nor the information contained herein shall be reproduced used, or disclosed to others without the written authorization of WALTER MEIER LTD., except to the extent required for installation or maintenance of recipient's equipment. All references to the NORTEC name should be taken as referring to WALTER MEIER LTD.



## LIABILITY NOTICE

WALTER MEIER LTD. does not accept any liability for installations of humidity equipment installed by unqualified personnel or the use of parts/components/equipment that are not authorized or approved by WALTER MEIER LTD.

## COPYRIGHT NOTICE

Copyright 2008, WALTER MEIER LTD. All rights reserved.

## SPECIFICATION LABEL LOCATION

The Specification Label for your NH Series Humidifier is located on the bottom of the unit. You will find it attached to the skirt that separates the electrical and plumbing compartments on the electrical compartment side.

## RECORD OF REVISIONS

For each revision, put the revised pages in your manual and discard the superseded pages. Write the revision number and revision date, date put in manual, and the incorporator's initials in the applicable columns on the Record of Revisions.

Revision Number	Revision Date	Date Put In Manual	By	Revision Number	Revision Date	Date Put In Manual	By

## TABLE OF CONTENTS

Subject	Page
<b>10-00 INTRODUCTION</b>	
1. PREINSTALLATION .....	3
A. RECEIVING & UNPACKING EQUIPMENT .....	3
2. PACKAGING .....	3
A. GENERAL .....	3
B. HUMIDIFIER AND CONTROLS BOX .....	3
C. DISTRIBUTOR BOX .....	3
D. ACCESSORIES BOX .....	3
3. PREINSTALLATION EQUIPMENT VERIFICATION .....	5
A. GENERAL .....	5
<b>10-10 INSTALLATION PROCEDURES</b>	
1. HUMIDIFIER INSTALLATION .....	10
A. LOCATION .....	10
B. MOUNTING WITH KEYHOLES .....	10
C. MOUNTING WITH WALL BRACKET .....	10
D. WATER SUPPLY LINE .....	11
E. DRAIN LINE .....	11
F. STEAM RUNS AND CONDENSATE RETURNS .....	11
G. ELECTRICAL .....	19
H. CONTROL WIRING .....	19
I. OPTIONAL OUTDOOR TEMPERATURE RESET FUNCTION .....	22
J. HUMIDITY TRANSDUCER SIGNAL INSTALLATION .....	23
K. NETWORKING NHTCS .....	23
L. NORTEC ONLINE INSTALLATION .....	23
<b>10-20 OPERATION</b>	
1. NHTC .....	28
A. NHTC COMPONENTS .....	28
B. HUMIDIFIER START-UP .....	28
C. BASIC STEAM PRODUCTION METHOD .....	28
D. CYLINDER LIFE .....	28
E. SOFTWARE INITIAL SELF-TEST .....	33
F. SOFTWARE FLOW CHART WITH DEFINITIONS .....	33
G. SELF-HELP .....	33
H. SYSTEM MESSAGES AND LIGHTS .....	41
I. DOUBLE UNIT OPERATION .....	41
2. STEAM DISTRIBUTION .....	44
A. STEAM DISTRIBUTOR OPERATION .....	44
B. SAM-E OPERATION .....	44
C. BLOWER PACK OPERATION .....	44
3. CONTROLS AND REMOTE COMMUNICATION (OPTIONAL) .....	46
A. DIGITAL CONTROL OPERATION .....	46
B. DIGITAL TRANSDUCER OPERATION .....	46
C. REMOTE CONNECTIONS (OPTIONAL) .....	46
D. NORTEC LINKS OPERATION .....	47
E. NORTEC ONLINE OPERATION .....	47
<b>10-30 MAINTENANCE PROCEDURES</b>	
1. NH ELECTRODE STEAM HUMIDIFIERS .....	50
A. MAINTENANCE .....	50
B. WHEN TO REPLACE THE STEAM CYLINDER .....	50
C. EXTENDED SHUT-DOWN .....	50
D. COMPONENTS OF THE STEAM CYLINDER .....	51

E.	HOW TO REMOVE THE STEAM CYLINDER .....	52
F.	MANDATORY CLEANING OF THE DRAIN VALVE .....	53
G.	HOW TO INSTALL THE REPLACEMENT CYLINDER .....	54
<b>10-40 TROUBLESHOOTING</b>		
1.	TROUBLESHOOTING NH ELECTRODE STEAM HUMIDIFIERS .....	56
A.	PREPARATION .....	56
B.	STARTING POINT .....	56
C.	NHTC/NHPC .....	56
2.	TROUBLESHOOTING DISTRIBUTORS .....	58
A.	TROUBLESHOOTING ATMOSPHERIC DISTRIBUTORS .....	58
3.	SAM-E TROUBLESHOOTING .....	58
A.	PROCEDURE .....	58
4.	BLOWER PACKS TROUBLESHOOTING .....	59
A.	PROCEDURE .....	59
5.	DIGITAL ON/OFF HUMIDISTAT SENSOR CALIBRATION .....	59
A.	PROCEDURE .....	59
6.	0-10V DIGITAL HUMIDISTAT SENSOR CALIBRATION .....	66
A.	PROCEDURE .....	66
<b>10-50 TECHNICAL</b>		
1.	WIRING AND TERMINALS .....	68
A.	HUMIDIFIER CONTROL INFORMATION .....	68
B.	NH WIRING .....	69
2.	CHECK LISTS .....	71
A.	PRE-NORTEC ONLINE START UP CHECKLIST WIRING .....	71
B.	PRE-NORTEC LINKS START-UP CHECKLIST .....	71
C.	HUMIDIFIER MANDATORY PRE-START UP CHECKLIST .....	72
D.	HUMIDIFIER MANDATORY START-UP CHECKLIST AND QUICK REFERENCE .....	73
E.	PERIODIC MAINTENANCE CHECKLIST AND QUICK REFERENCE .....	74
3.	SPARE PARTS AND EXPLODED VIEWS .....	76
A.	ASD, BSD, CSD DISTRIBUTOR .....	76
B.	SAM-E SPARE PARTS .....	76
C.	NH SERIES HUMIDIFIER SPARE PARTS .....	77

**WARRANTY**

## LIST OF FIGURES

Figure		Page
<b>10-00 INTRODUCTION</b>		
Figure 1.	NHTC .....	2
Figure 2.	Humidifier Box .....	4
Figure 3.	Distributor Box .....	4
Figure 4.	SAM-e Distributor Box .....	4
Figure 5.	Remote Mounted Blower Pack Box .....	4
Figure 6.	Typical NHTC Installation .....	6-7
<b>10-10 INSTALLATION PROCEDURES</b>		
Figure 1.	Clearances and Operating Conditions .....	12
Figure 2.	Mounting with Keyholes .....	12
Figure 3.	Mounting with Mounting Bracket .....	12
Figure 4.	Drain Water and Supply Connection .....	13
Figure 5.	Steam Run and Condensate Return Installation Guidelines .....	15
Figure 6.	Steam Run and Condensate Return Installation Guidelines .....	16
Figure 7.	Primary Voltage Supply Wiring .....	18
Figure 8.	On-Off Control Guidelines and Low Voltage Terminal Strip .....	20
Figure 9.	NORTEC Control Guidelines and Wiring (Optional) .....	21
Figure 10.	Setpoint Versus Outdoor Temperature .....	22
Figure 11.	NORTEC Humidity Transducer Guidelines and Wiring (Optional) .....	24
Figure 12.	Networking NHTCs (Optional) .....	25
Figure 13.	NORTEC OnLine Installation Guidelines (Optional) .....	26
<b>10-20 OPERATION</b>		
Figure 1.	NHTC Components (Front View) .....	28
Figure 2.	NHTC Components (Side View) .....	28
Figure 3.	Humidifier Start-Up .....	31
Figure 4.	Drain Rate Versus Water Conductivity .....	31
Figure 5.	Capacity Setting and Cylinder Life .....	31
Figure 6.	Basic Steam Production Method .....	32
Figure 7.	Software Flow Chart .....	34
Figure 8.	Steam Distributor Operation .....	44
Figure 9.	SAM-e Operation .....	45
Figure 10.	Blower Pack Operation and Adjustments .....	45
Figure 11.	NORTEC Digital Controller .....	46
Figure 12.	Difference from Setpoint in Relation to Demand Signal .....	47
Figure 13.	Duct and Wall Mounted Transducer .....	47
<b>10-30 MAINTENANCE PROCEDURES</b>		
Figure 1.	Cylinder Components .....	51
Figure 2.	Cylinder Removal Procedure .....	52
Figure 3.	Drain Valve Maintenance .....	53
Figure 4.	Cylinder Replacement Procedure .....	54
<b>10-50 TECHNICAL</b>		
Figure 1.	NHTC/NHPC Double Unit Wiring Diagram .....	69
Figure 2.	NHTC/NHPC Wiring Diagram .....	70
Figure 3.	Distributor Exploded View and Spare Parts .....	76
Figure 4.	SAM-e Exploded View and Spare Parts .....	76
Figure 5.	NHTC/NHPC Plumbing Compartment Exploded View and Spare Parts .....	77
Figure 6.	NHTC/NHPC Electrical Compartment Exploded View and Spare Parts .....	80

## LIST OF TABLES

Table	Page
<b>10-10 INSTALLATION PROCEDURE</b>	
Table 1. Maximum Recommended Length of Steam Runs .....	14
Table 2. Steam Line Material .....	14
Table 3. Recommended Material and Size for Steam Run .....	14
Table 4. Recommended Condensate Line at Distributor(s) .....	17
Table 5. Equivalent Length Elbow and T-Fittings .....	17
Table 6. Humidifier and Distributor Inlet/Outlet Sizes .....	17
<b>10-20 OPERATION</b>	
Table 1. NHTC / NHPC Components .....	29-30
Table 2. Self-Test Messages .....	32
Table 3. Signal Light Status .....	41
Table 4. Status Messages with LED State .....	42
<b>10-40 TROUBLESHOOTING</b>	
Table 1. Troubleshooting Symptoms .....	57
Table 2. Ensuring A Demand Signal .....	58
Table 3. NH System Messages .....	60
Table 4. Term Definitions .....	66
<b>10-50 TECHNICAL</b>	
Table 1. Controller and Sensor Specifications .....	68
Table 2. NHTC/NHPC Plumbing Part List .....	78
Table 3. NHTC/NHPC Electrical Parts List .....	81



# 10-00

# INTRODUCTION





**Figure 1. NHTC**

## **1. PRE-INSTALLATION**

### **A. RECEIVING & UNPACKING EQUIPMENT**

- (1) Check packing slip to ensure ALL material has been delivered.
- (2) All material shortages are to be reported to NORTEC within 48 hours from receipt of goods. NORTEC assumes no responsibility for any material shortages beyond this period.
- (3) Inspect shipping boxes for damage and note damages on shipping waybill accordingly.
- (4) After unpacking, inspect equipment for damage and if damage is found, notify the shipper promptly.
- (5) All NORTEC products are shipped on an FOB factory basis. Any and all damage, breakage or loss claims are to be made directly to the shipping company.

## **2. PACKAGING**

### **A. GENERAL**

- (1) The equipment packaging is standardized in that each box in the shipment will always have the same contents. The following paragraphs identify the contents of each box.

### **B. HUMIDIFIER AND CONTROLS BOX**

- (1) The typical equipment found in the humidifier and controls box is shown in Figure 2. The contents of the box are listed on the box. If controls are ordered they will be listed and small accessories that fit into the box will also be listed on the box.

### **C. DISTRIBUTOR BOX**

- (1) Depending on the equipment ordered any of the following distributor box configurations may be received:
  - a. For equipment received if an ASD, BSD, CSD distributor(s) is ordered refer to Figure 3.
  - b. For equipment received if a SAM-e distributor is ordered refer to Figure 4.
  - c. For equipment received if a RMBP is ordered refer to Figure 5.

### **D. ACCESSORIES BOX**

- (1) Additional accessories such as DWC, DWSP, Filter, and Fill cup extension kits are shipped in a separate box. Smaller accessories that would fit in the humidifier box are put in the humidifier box and the box is identified as containing such.

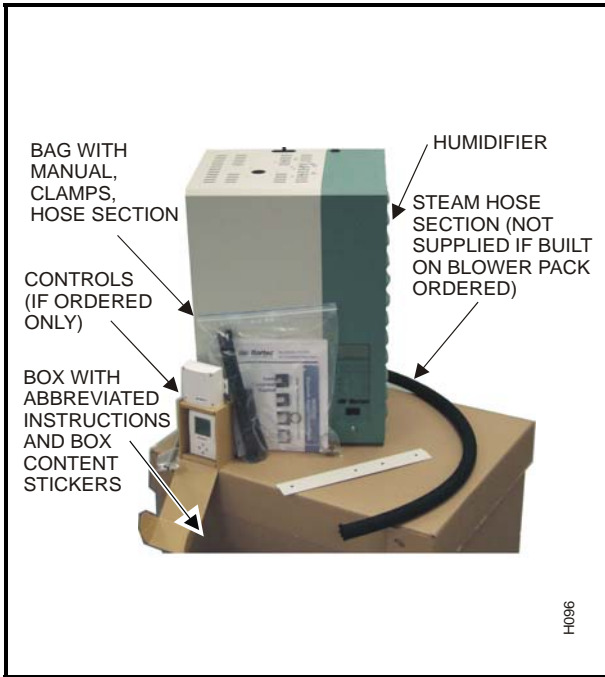

**Figure 2. Humidifier Box**

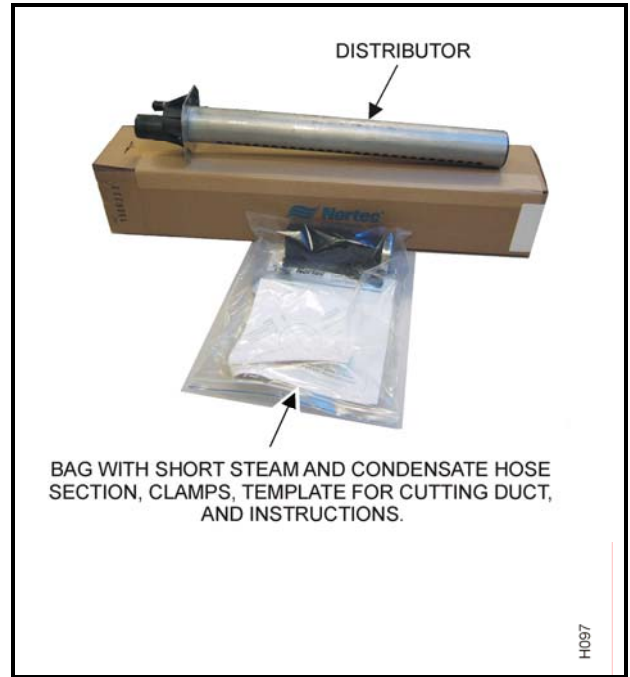

**Figure 3. Distributor Box**

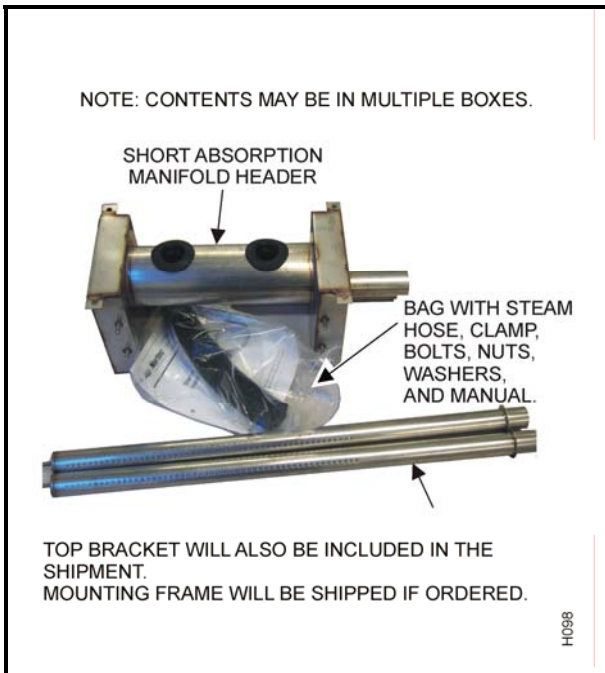

**Figure 4. SAM-e Distributor Box**



**Figure 5. Remote Mounted Blower Pack Box**

### **3. PREINSTALLATION EQUIPMENT VERIFICATION**

#### **A. GENERAL**

- (1) Ensure that available voltage and phase corresponds with humidifier voltage and phase as indicated on humidifier's specification label.
- (2) Ensure that the dedicated external fuse disconnect is of sufficient size to handle the rated amps as indicated on the specification label. Refer to local codes.
- (3) Report any discrepancy immediately to the site engineer.
- (4) Location and mounting is described in Chapter 10-10.
- (5) Typical installation (See Figure 6.) shows the references to the appropriate chapter of the manual.

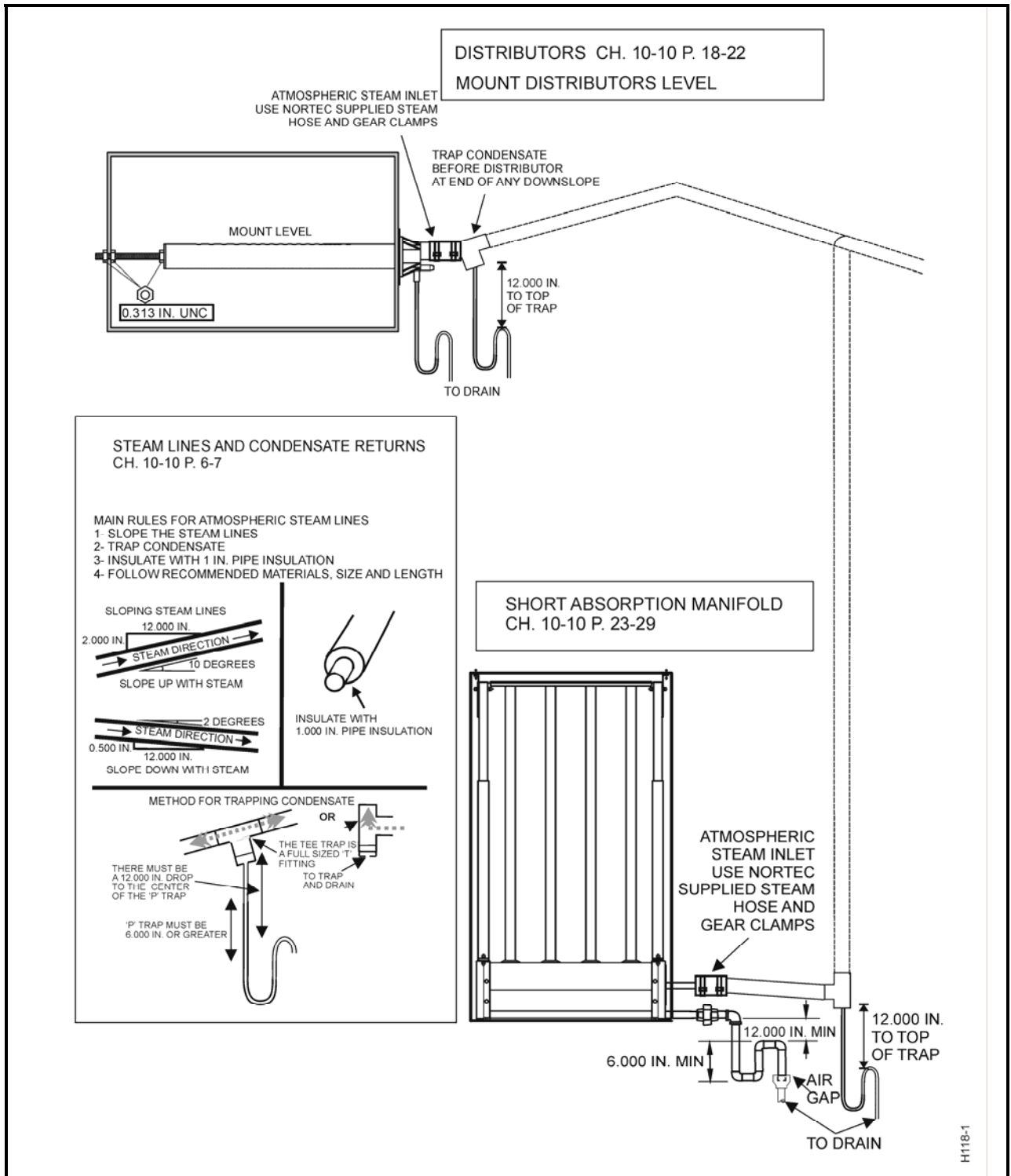

Figure 6. Typical NHTC Installation (Sheet 1 of 2)

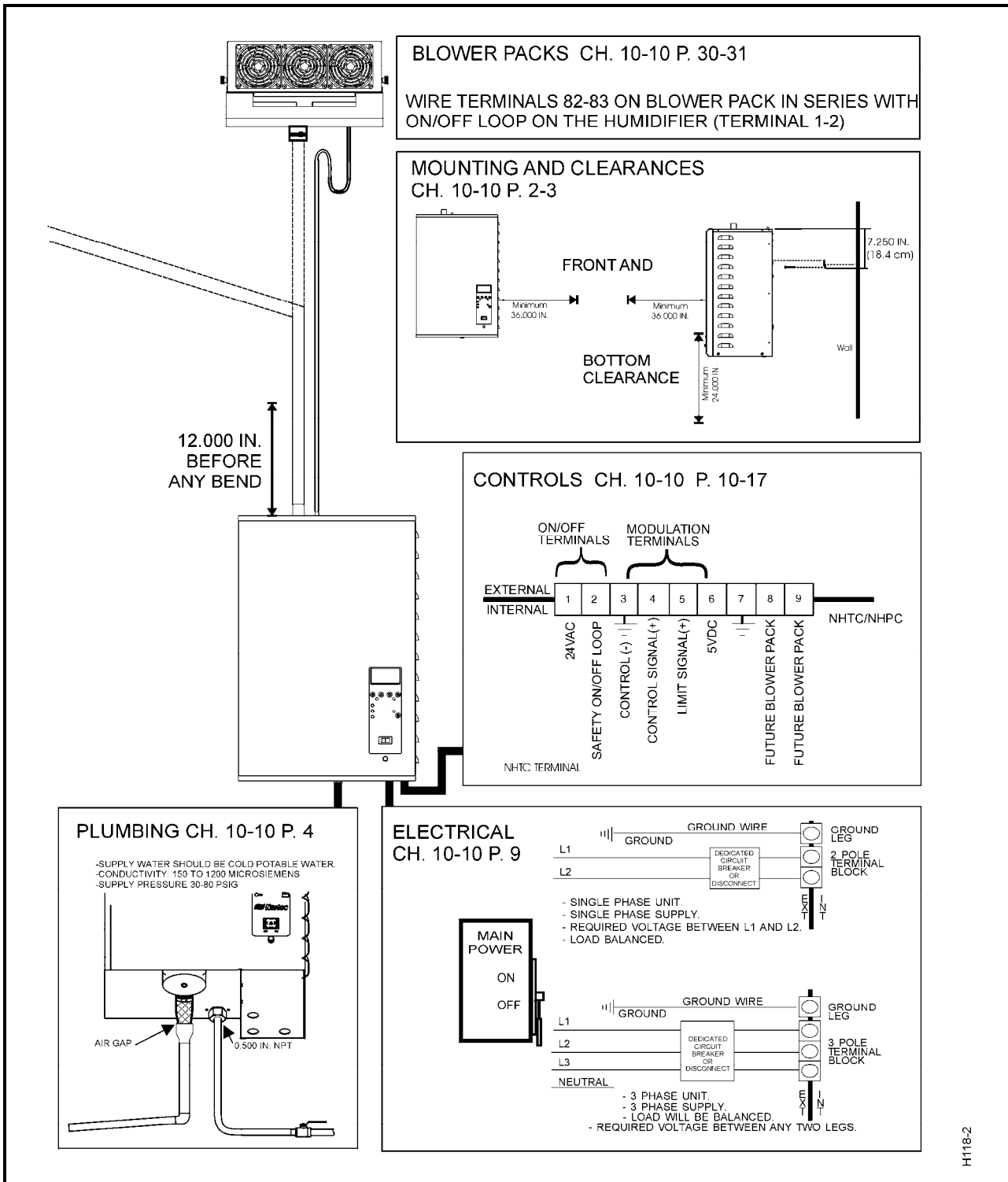

Figure 7. Typical NHTC Installation (Sheet 2 of 2)

**THIS PAGE INTENTIONALLY LEFT BLANK**

# 10-10 INSTALLATION



## 1. HUMIDIFIER INSTALLATION

### A. LOCATION

- (1) The NORTEC NHTC series humidifier is designed to mount on a suitable wall or vertical surface. Do not sit the unit on the floor due to clearances required for plumbing and electrical connections. The clearance dimensions shown in this manual are for reference only and are the minimum required for maintenance on the humidifier. Local and national codes should be consulted before final location and installation of the humidifier. NORTEC cannot accept responsibility for installation code violations. See Figure 1 Clearances and Operating Conditions.
- (2) The location of the humidifier should be below the steam distributor. DO NOT locate the humidifier any further then absolutely necessary from the steam distributor location as net output will be reduced as a result of heat loss through the steam line.
- (3) When possible, mount the NHTC humidifier at a height convenient for servicing.

### B. MOUNTING WITH KEYHOLES

- (1) The NHTC series humidifier is wall mounted using keyholes located on the back of the unit's cabinetry. The keyholes are spaced 16 inches apart center to center for large units and 10.7 inches apart for small as per UL certification standard stud spacing dictates.
- (2) Use #12 x 3 in. screws. 2 screws are needed for a single unit (NHTC 010 to 100 lbs/hour). 3 screws are needed for a double unit (NHTC 150 to 200 lbs/hour). Insert the screw 16 in. apart. Be sure the screws are level to each other. Proceed to insert the screws into the studs until there is 1/4 in. of screw exposed. Ensure the screws are properly anchored to the wall.
- (3) Raise the unit. Align the keyholes on the back of the unit with the screws. Place the screws through the keyholes. Make sure the unit is level then tighten the screws to secure the unit in place.
- (4) Once the unit is securely fixed to the wall, install the "L" shaped brackets into the same studs the unit is attached to. Place the brackets on top of the unit, inline with the studs. Using the appropriate sized wood screw fasten the "L" brackets to the studs securing the unit from any upward motion. See Figure 2 Mounting with keyhole.

### C. MOUNTING WITH WALL BRACKET

- (1) For NHTC units that mount using a Wall mounting bracket 3 x #12 3.0 inch wood screws are to be used.
- (2) Wall mounting bracket provided should be securely attached horizontally with open edge upwards, using field-supplied fasteners. Be sure the bracket is mounted level See Figure 3.
- (3) If humidifiers are mounted on a roof, a thermostatically ventilated weather proof cabinet should be used. Consult factory.

#### **D. WATER SUPPLY LINE**

- (4) All water supply and drain line connections should be installed in accordance with local plumbing codes.
- (5) For installation details see Figure 5 & 6.

#### **E. DRAIN LINE**



#### **CAUTION**

**DRAIN WATER FROM HUMIDIFIER CAN BE VERY HOT.**

- (1) The drain line should not end in a sink used frequently by personnel, or where plumbing codes prohibit it. Route to a floor drain or equivalent for safety reasons.
- (2) For installation details see Figure 4.

#### **F. STEAM RUNS AND CONDENSATE RETURNS**

- (1) Tables 1 through 6 indicate what material and recommended length to use when installing atmospheric steam lines. The lengths mentioned are equivalent feet and therefore the full length of tubing with the addition of equivalent feet of elbows and tees.
- (2) Figure 5 illustrates the guidelines for installation, routing and trapping of steam runs and condensate returns.
- (3) Table 6 indicates steam outlet size of humidifier and steam inlet size of distributors.

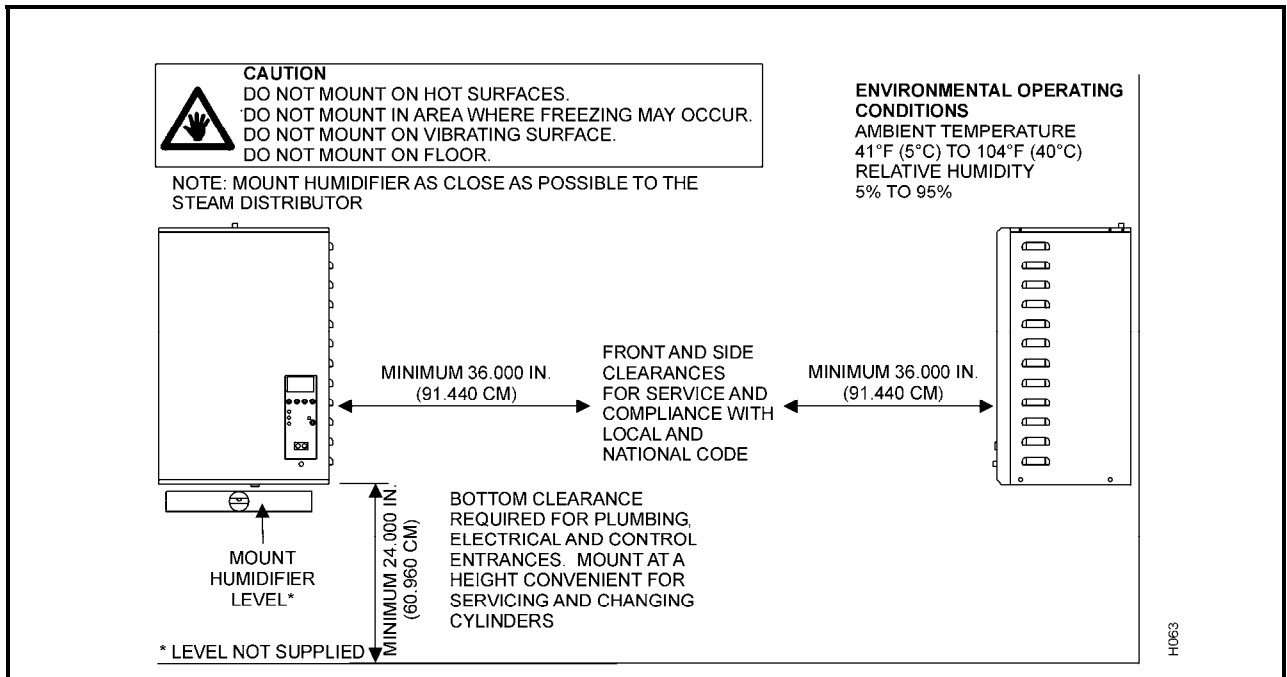

**Figure 1. Clearances and Operating Conditions**

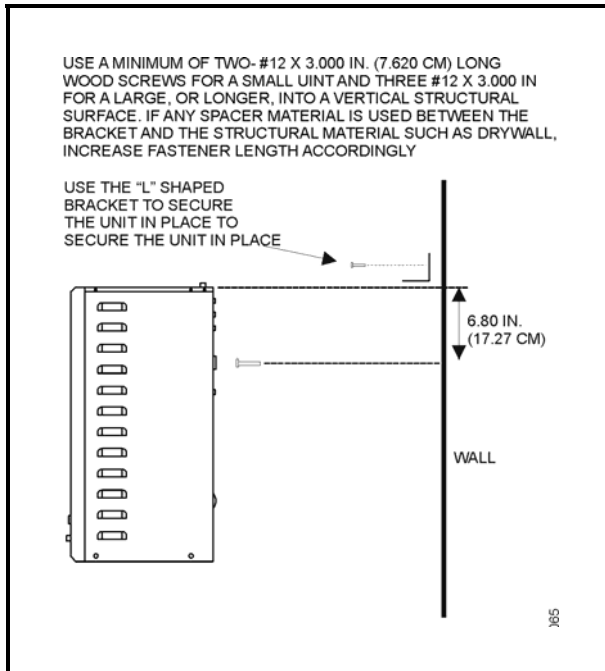

**Figure 2. Mounting with Keyholes**

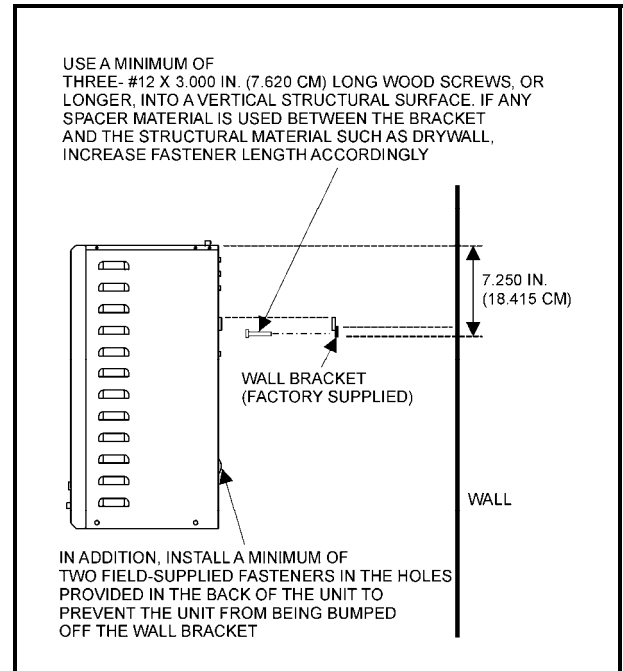

**Figure 3. Mounting with Mounting Bracket**

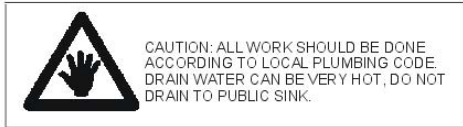

-SUPPLY WATER SHOULD BE COLD POTABLE WATER.  
-SOFTENER MAY BE USED IF CONDUCTIVITY REMAINS IN RECOMMENDED RANGE.

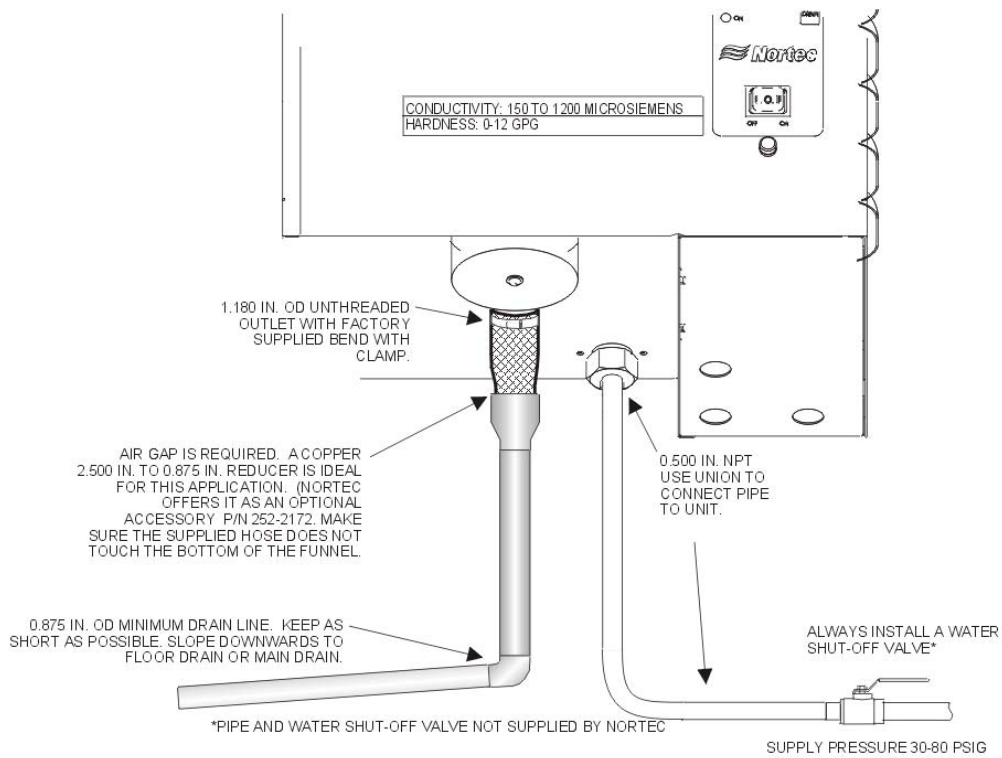

H070

**Figure 4. Drain Water and Supply Connection**

**Table 1. Maximum Recommended Length of Steam Line**

Unit Size	Steam Output	Distance	Possible Loss	Steam Line Size
NH-005	5 lbs/hr	8 feet	1.0 lbs/hr	3/4
NH-010	10 lbs/hr	15 feet	1.5 lbs/hr	3/4
NH-020	20 lbs/hr	20 feet *	2.0 lbs/hr	3/4
NH-030	30 lbs/hr	25 feet *	2.5 lbs/hr	3/4
NH-050	50 lbs/hr	40 feet **	4.0 lbs/hr	1 1/2"
NH-075	75 lbs/hr	50 feet **	5.0 to 10.0 lbs/hr	1 1/2"
NH-100	100 lbs/hr	50 feet **	5.0 to 10.0 lbs/hr	1 1/2"
NH-150	150 lbs/hr	50ft/cylinder **	5.0 to 10.0 lbs/hr	1 1/2" cyl
NH-200	200 lbs/hr	50ft/cylinder **	5.0 to 10.0 lbs/hr	1 1/2" cyl

\* Use one inch copper steam line for longer runs.  
\*\* Use two inch copper steam line for longer runs.

Notes: 1. This table gives the maximum recommended steam run by unit size.  
2. The use of steam line other than copper, stainless steel tube or Nortec supplied steam line will void the warranty and may adversely effect the operation of the humidifier  
3. The NH-150 and NH-200 are dual units.

**Table 2. Steam Line Materials**

	NORTEC Steam Line	Copper Tube (Potable)	Stainless Steel Tube (RO or DI)
Short Run < 10 feet (3m)	yes	yes	yes
Long Run > 10 feet (3m)	no	yes	yes

**NOTE**

Do not use plastic, steel, or black iron. Long runs affect accuracy of humidifier and its ability to quickly respond to changes in demand when tight control is required.

**Table 3. Recommended Materials and Sizes for Steam Runs**

Unit Size		Steam Run		Steam Line Material	Steam Line Description
lbs/hr	kg/hr	ft	m		
0-30	0-13	0-10	0-3	Copper Tube	0.750 in MED-L Tubing (0.875 inch OD)
<b>0-30</b>	<b>0-13</b>	<b>30+</b>	<b>3+</b>	<b>Copper Tube</b>	<b>1.0 inch MED-L Tubing (1.125 inch OD)</b>
0-30	0-13	0-10	0-3	Stainless Steel Tube	0.875 inch Tube x 0.049 inch thick
<b>0-30</b>	<b>0-13</b>	<b>30+</b>	<b>3+</b>	<b>Stainless Steel Tube</b>	<b>1.125 inch Tube x 0.049 inch thick</b>
50-100	22-45	0-20	0-6	Copper Tube	1.500 in MED-L Tubing (1.625 inch OD)
<b>50-100</b>	<b>22-45</b>	<b>20+</b>	<b>6+</b>	<b>Copper Tube</b>	<b>2.0 inch MED-L Tubing (2.125 inch OD)</b>
50-100	22-45	0-20	0-6	Stainless Steel Tube	1.750 inch Tube x 0.065 inch thick
<b>50-100</b>	<b>22-45</b>	<b>20+</b>	<b>6+</b>	<b>Stainless Steel Tube</b>	<b>2 inch Tube x 0.065 inch thick</b>

**NOTE**

Options show in **bold-italic** font require that reducers be used at both ends. These extra large sizes are to allow for better condensation removal in long steam runs. These sizes do not permit the use of hose couplings to connect either humidifier or distributors.  
Insulate steam lines with 1" pipe insulation.

NOTE: ALWAYS CONSULT MATERIAL, SIZE AND LENGTH TABLES IN CONJUNCTION WITH THESE GUIDELINES

**MAIN RULES FOR ATMOSPHERIC STEAM LINES**

- 1- SLOPE THE STEAM LINES
- 2- TRAP CONDENSATE
- 3- INSULATE WITH 1.000 IN. PIPE INSULATION
- 4- FOLLOW RECOMMENDED MATERIALS, SIZE AND LENGTH

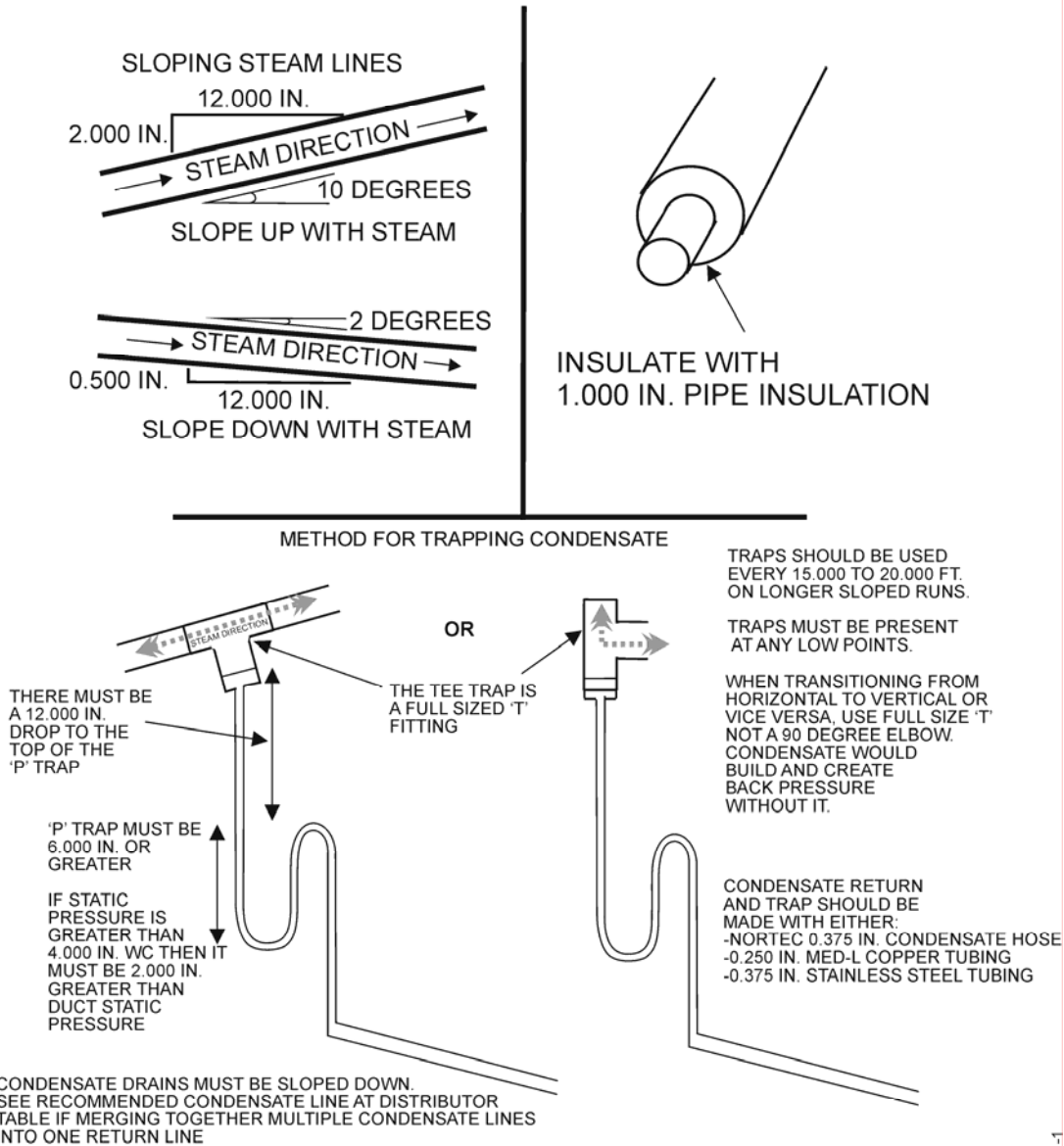

**Figure 5. Steam Run and Condensate Return Installation Guidelines (Sheet 1 of 2)**

NOTE: CONDENSATE CAN BE RETURNED TO FILL CUP ON THE HUMIDIFIER, DRAIN OF UNIT, SUMP PUMP, OR OTHER SAFE LOCATION

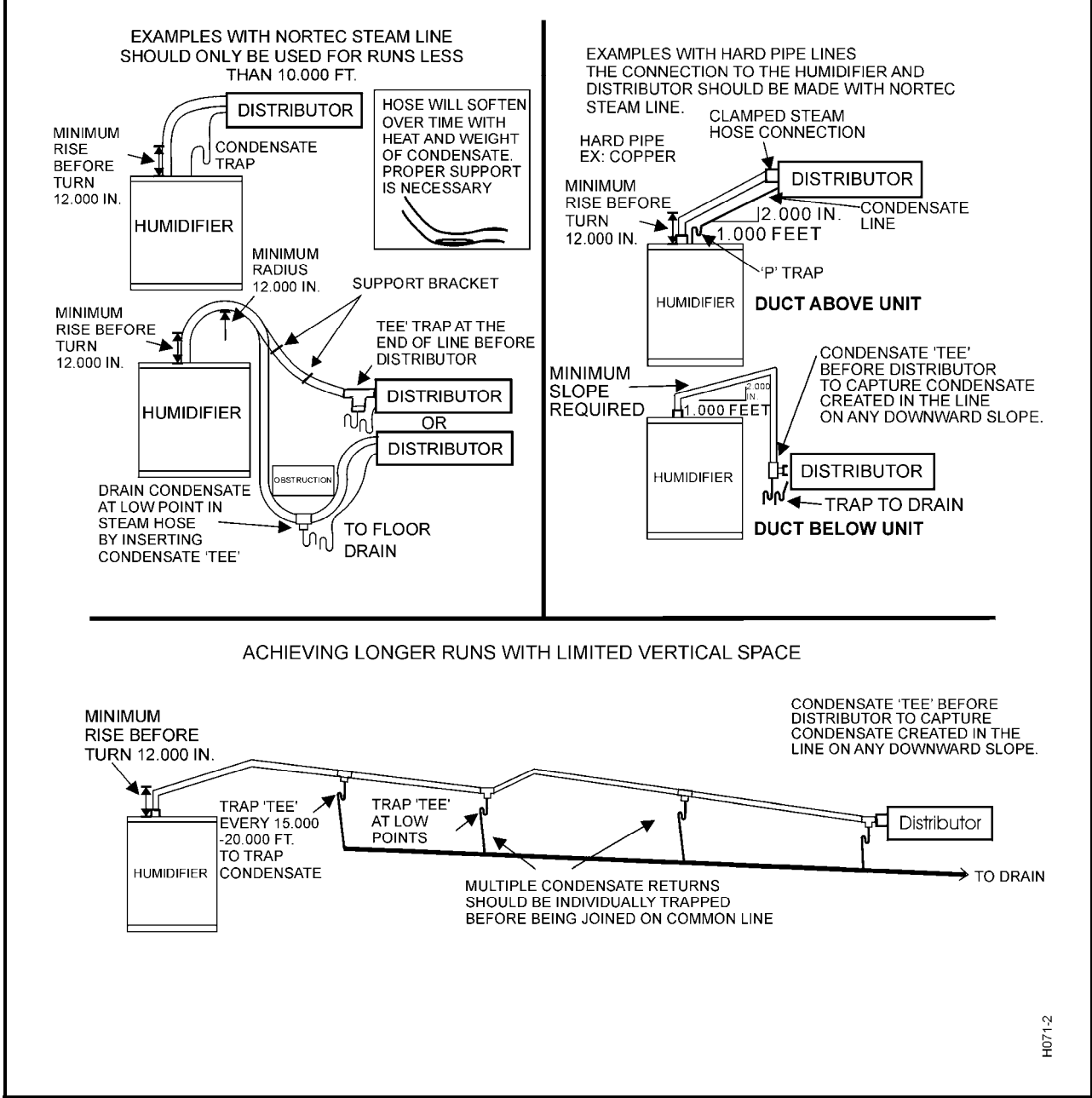

Figure 6. Steam Run and Condensate Return Installation Guidelines (Sheet 1 of 2)

**Table 4. Recommended Condensate Line at Distributor(s)**

Dispersion Method	Condensate Hose	Copper Tube (Potable)	Stainless Steel Tube (RO or DI)
1 x Steam Distributor	0.375 inch NORTEC 132-8840	0.250 inch. MED-L Tubing (0.375 inch OD)	0.375 Tube 0.049 inch thick
3 x Steam Distributor	0.375 inch NORTEC 132-8840	0.500 inch. MED-L Tubing (0.875 inch OD)	0.650 Tube 0.049 inch thick

Note: \*When using more than 1 steam distributor, the condensate line must be trapped before it is joined together. See figure 4

**Table 5. Equivalent Lengths of Elbows and Tee Fittings**

Nominal Tube Diameter	Standard 90degree Elbow	Standard 45 degree Elbow	Side Outlet Tee
0.750 / 0.875 in.	2 ft.	1 ft.	4 ft.
1.500 / 1.750 in.	3 ft. 6 in.	1ft. 9 in.	7 ft.
2.000 / 2.500 in.	4 ft. 6 in.	2 ft. 3 in.	10 ft.

**Table 6. Humidifier and Distributor Inlet/Outlet Sizes**

Humidifier	Steam Outlet	Distributor	Steam Inlet
NH 5-30	0.875 in. OD	ASD, BSD	0.875 inch OD
NH 50-100	1.75 in. OD	CSD	1.75 inch OD
NH 150-200	Two 1.75 in. OD	Blower Pack	0.875 inch OD or 1.75 inch OD
		SAM-e	1.75 inch OD*
		mini SAM-e	0.875 or 1.75 inch OD**

NOTE: \* SAM-e may have multiple 1.75 in. inlets depending on order.

\*\* mini SAM-e inlet is determined on order and may have two 1.75 in. OD inlets.



 WIRING TO BE PERFORMED BY A LICENSED ELECTRICIAN.

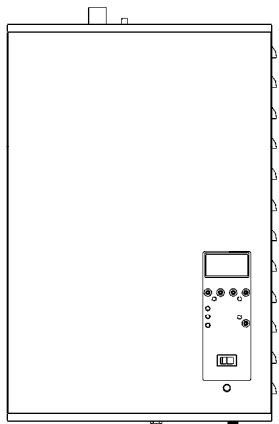

OPTIONAL INTERNAL FUSES ARE NOT INTENDED TO SUBSTITUTE FOR EXTERNAL FUSES. THIS OPTION IS STRICTLY TO PROVIDE PROTECTION FOR THE INTERNAL WIRES INDIVIDUALLY.

A DEDICATED EXTERNAL FUSED DISCONNECT MUST BE INSTALLED. DO NOT EXCEED THE MAXIMUM CIRCUIT PROTECTION AMPS AS INDICATED ON THE SPECIFICATION LABEL.

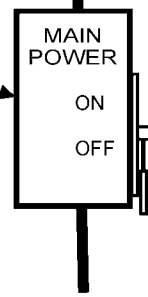

ENSURE THAT ADEQUATE POWER SUPPLY IS AVAILABLE TO CARRY FULL HUMIDIFIER AMPERAGE DRAWN AS SPECIFIED BY SPECIFICATION LABEL.

PRIMARY (LINE) VOLTAGE WIRING TO UNIT (BY OTHERS)

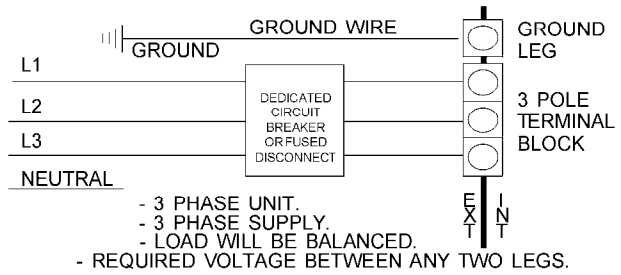
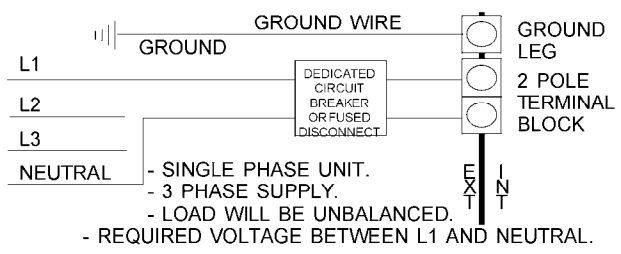
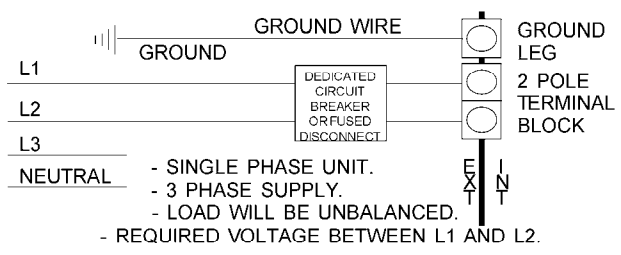
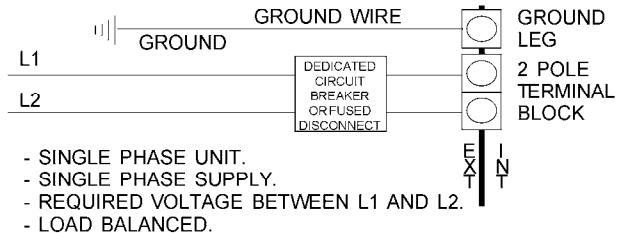

NOTE: VOLTAGE AT TERMINAL BLOCK MUST BE IN ACCORDANCE WITH SPECIFICATION LABEL. ALL WIRING TO BE IN ACCORDANCE WITH EXISTING NATIONAL AND LOCAL ELECTRICAL CODES.

H072

**Figure 7. Primary Voltage Supply Wiring**

## G. ELECTRICAL

### (1) Primary Voltage Supply Wiring to Humidifier

- (a) Local electrical codes should always be followed when installing a NORTEC Humidifier. Direct wiring to the high voltage terminal is shown in Figure 7.

## H. CONTROL WIRING

- (1) Controls are available from NORTEC as accessories. If controls were not ordered with humidifier, they must be purchased or supplied by others. The following information is relevant to all controls, factory supplied or otherwise.



### CAUTION

**REGARDLESS OF SELECTING ON/OFF OR MODULATING CONTROL METHOD, NORTEC HUMIDIFIERS MUST HAVE A CLOSED CIRCUIT ACROSS ITS ON/OFF SECURITY LOOP CONTROL TERMINAL TO OPERATE. NORTEC HIGHLY RECOMMENDS THE USE OF A HIGH LIMIT HUMIDISTAT AND AN AIR PROVING SWITCH IN SERIES FOR THIS FUNCTION.**

### (a) On-Off Controls

The method and guidelines for installing on/off controls are displayed in Figure 8. It can be combined with all control methods.

### (b) Demand Signal Controls Installation

Figure 9 uses the Nortec optional Controllers to demonstrate the typical demand signal installation.

NOTE: NORTEC Controls are optional accessories.  
 NORTEC recommends the use of on/off safeties in the safety loop.  
 Be aware that terminal 1 is hot, 24 VAC, and therefore the unit should be off when wiring

Part #	Description
252-0259	Digital On/Off Wall Humidistat
252-0273	Digital On/Off Duct Humidistat Package

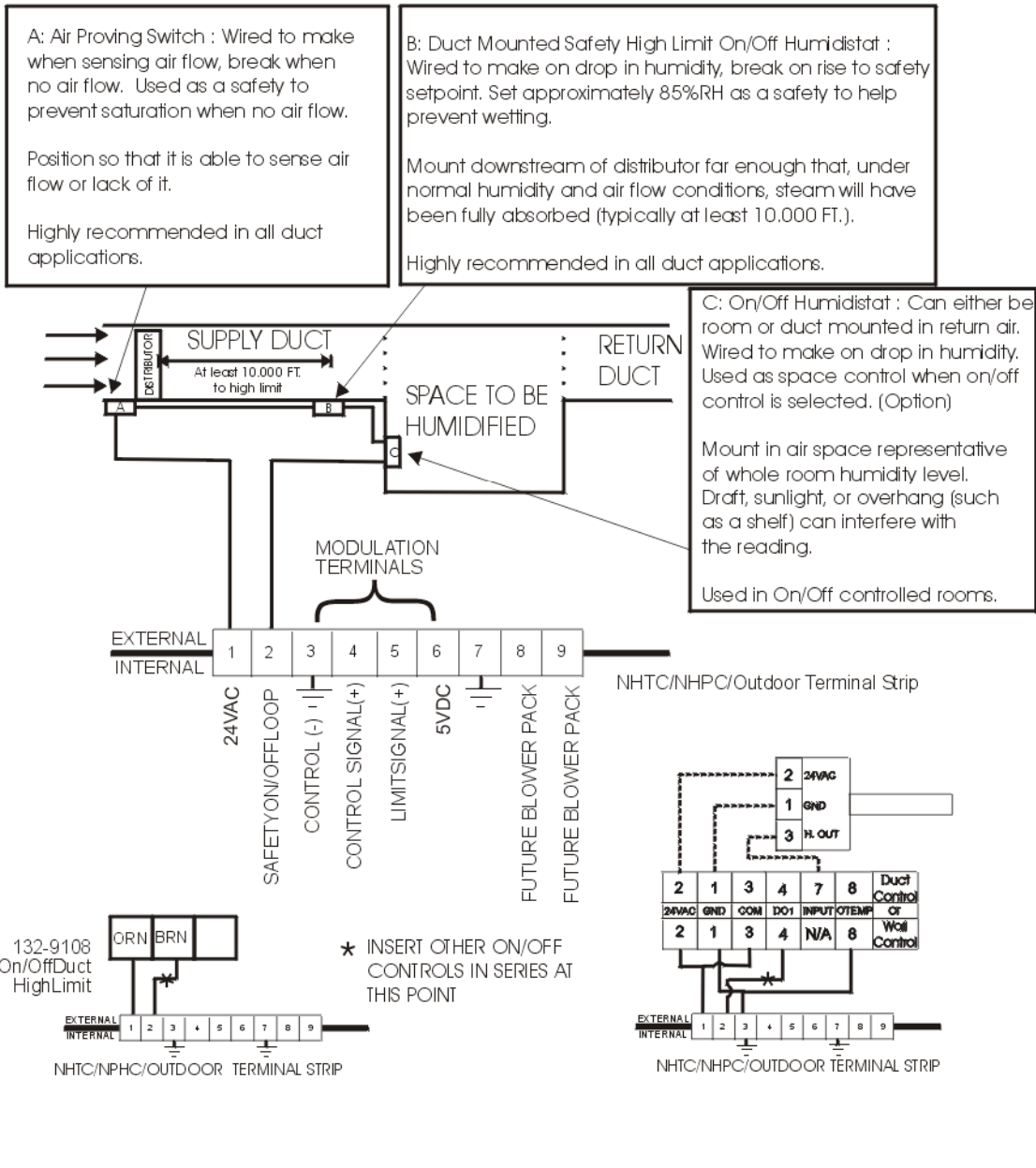
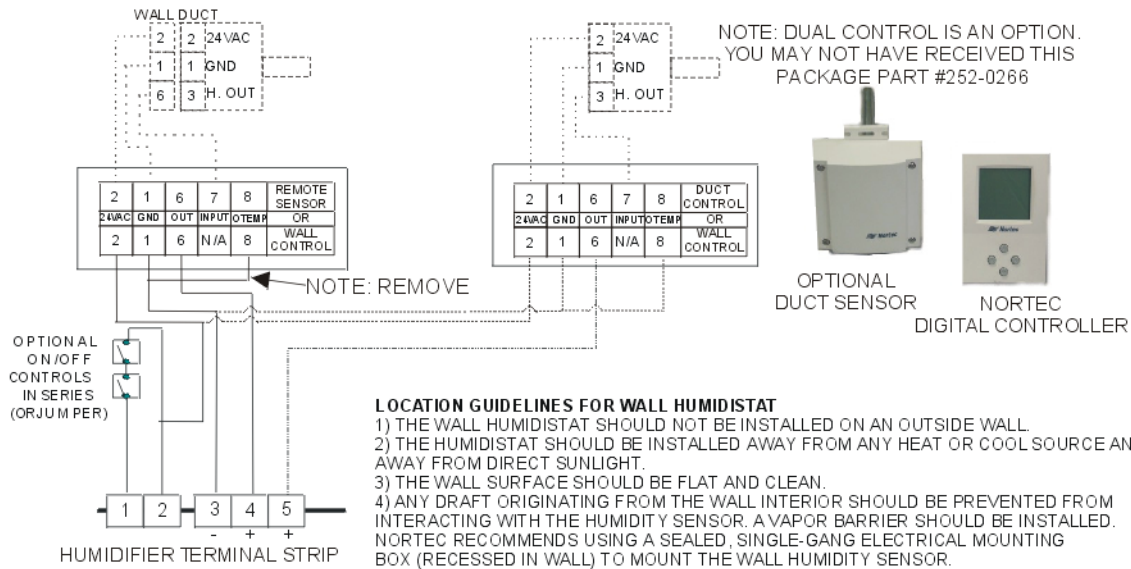

Figure 8. On/Off Control Guidelines and Low Voltage Terminal Strip

H074

CABLING BETWEEN CONTROLS AND UNIT SHOULD BE SHIELDED 18 AWG

PART #	DESCRIPTION
151-0142	0-10V DIGITAL WALL HUMIDISTAT (HAS BUILT IN SENSOR)
252-0266	0-10V DIGITAL DUCT HUMIDISTAT PACKAGE (INCLUDES DUCT MOUNTED SENSOR)
252-0261	0-10V DIGITAL WALL W/O SENSOR HUMIDISTAT (USED WITH SENSOR PART # 150-9858)



**LOCATION GUIDELINES FOR WALL HUMIDISTAT**

- 1) THE WALL HUMIDISTAT SHOULD NOT BE INSTALLED ON AN OUTSIDE WALL.
- 2) THE HUMIDISTAT SHOULD BE INSTALLED AWAY FROM ANY HEAT OR COOL SOURCE AND AWAY FROM DIRECT SUNLIGHT.
- 3) THE WALL SURFACE SHOULD BE FLAT AND CLEAN.
- 4) ANY DRAFT ORIGINATING FROM THE WALL INTERIOR SHOULD BE PREVENTED FROM INTERACTING WITH THE HUMIDITY SENSOR. A VAPOR BARRIER SHOULD BE INSTALLED. NORTEC RECOMMENDS USING A SEALED, SINGLE-GANG ELECTRICAL MOUNTING BOX (RECESSED IN WALL) TO MOUNT THE WALL HUMIDITY SENSOR.

**LOCATION GUIDELINES FOR DUCT SENSORS**

- 1) THE DUCT SENSOR SHOULD BE INSTALLED ON OUTSIDE OF DUCT WALL WITH THE SENSOR INSERTED INTO DUCT, WHERE THE AIR IS WELL MIXED WITH UNIFORM FLOW.
- 2) THE HIGH LIMIT SENSOR SHOULD BE MOUNTED DOWNSTREAM OF THE STEAM DISTRIBUTOR AT A DISTANCE 1.5 TIMES THE ABSORPTION DISTANCE. (TYPICALLY 10,000-12,000 FT. OR 3-3.7 M)
- 3) IF A RETURN AIR HUMIDITY SENSOR IS USED IT SHOULD BE MOUNTED CLOSE TO THE AIR INLET BUT DOWNSTREAM FROM A RETURN FAN IF ONE IS PRESENT.

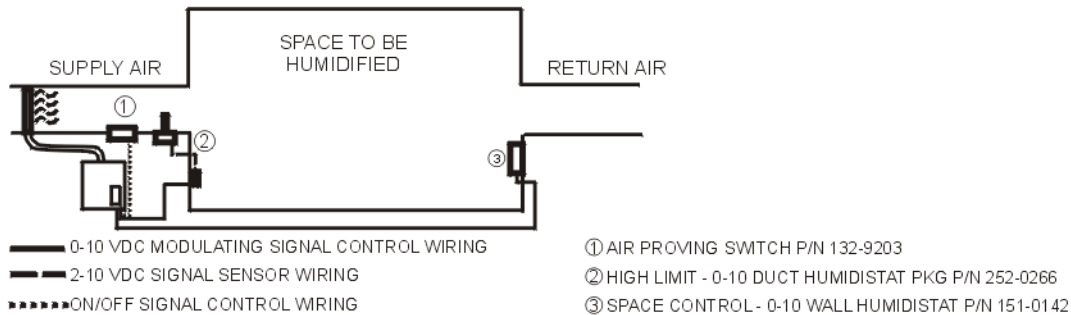

NOTE: 1. FAILURE TO WIRE THE HUMIDISTAT IN ACCORDANCE WITH THE WIRING DIAGRAM COULD CAUSE PERMANENT DAMAGE. SUCH ERRORS WILL VOID THE WARRANTY.  
2. USING THE NETWORK STAGED MODULATION OPTION CAN BE USED TO CONTROL MULTIPLE HUMIDIFIERS WITH A SINGLE SET OF CONTROLS.

H075

**Figure 9. NORTEC Control Guidelines and Wiring (Optional)**

## I. OPTIONAL OUTDOOR TEMPERATURE RESET FUNCTION

### NOTE

Order outdoor temperature sensor separately, Part #252-0263.

- (1) Each humidistat and controller is equipped with an integrated reset function that will limit the setpoint during cold weather operation. This will prevent condensation on windows and building structures. Figure 10 illustrates how the setpoint reset feature operates.
- (2) This feature is enabled by removing the jumper from terminals 8 and 1 on the humidistat and wiring the outdoor temperature sensor to these terminals.
- (3) When the outdoor temperature setback feature is in effect, the humidistat will normally display the calculated setpoint limit based on the outdoor air temperature. A snowflake will also be displayed to indicate cold weather operation. When any key on the controller is pressed, the LCD screen will display the customer specified setpoint for a short duration.

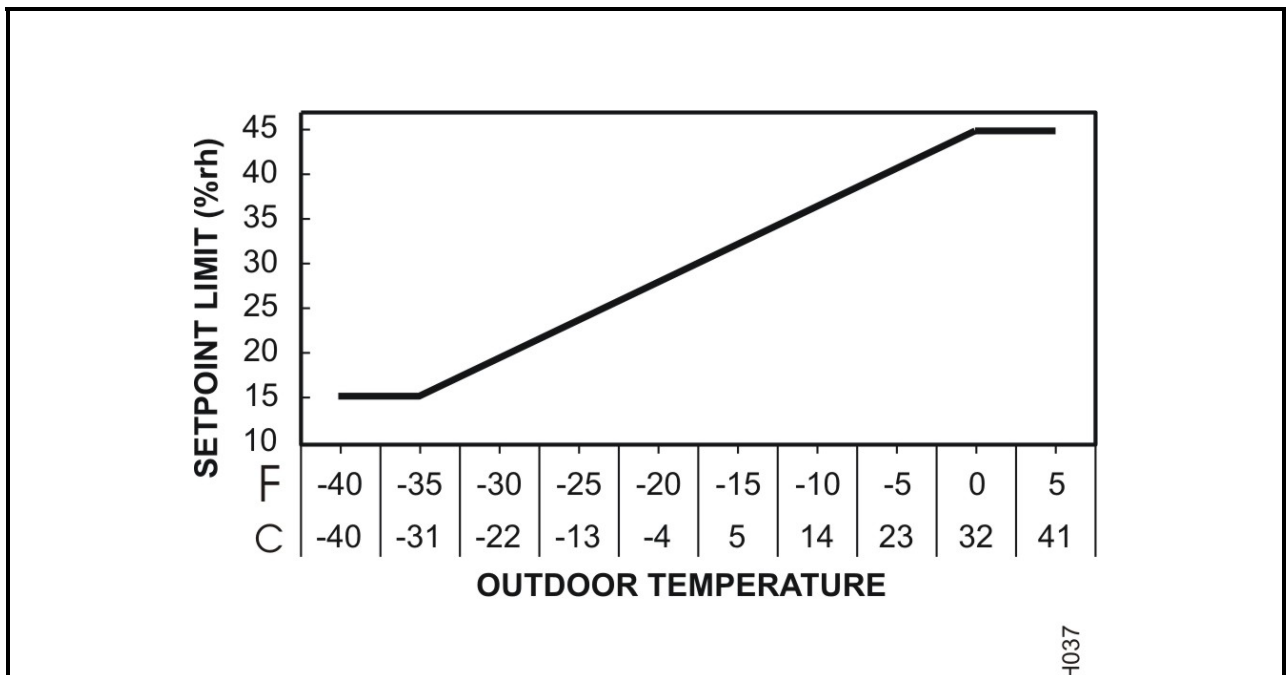

Figure 10. Setpoint Versus Outdoor Temperature

**J. HUMIDITY TRANSDUCER SIGNAL INSTALLATION**

- (1) Figure 11 displays the NORTEC optional humidity transducer installation.

**K. NETWORKING NHTC**

- (1) The wiring of master/slave networks are explained in Figure 12. It allows operation of multiple NHTCs with one control signal.

**L. NORTEC ONLINE INSTALLATION**

- (1) An abbreviated recommended installation of NORTEC OnLine and its components are shown in Figure 13.

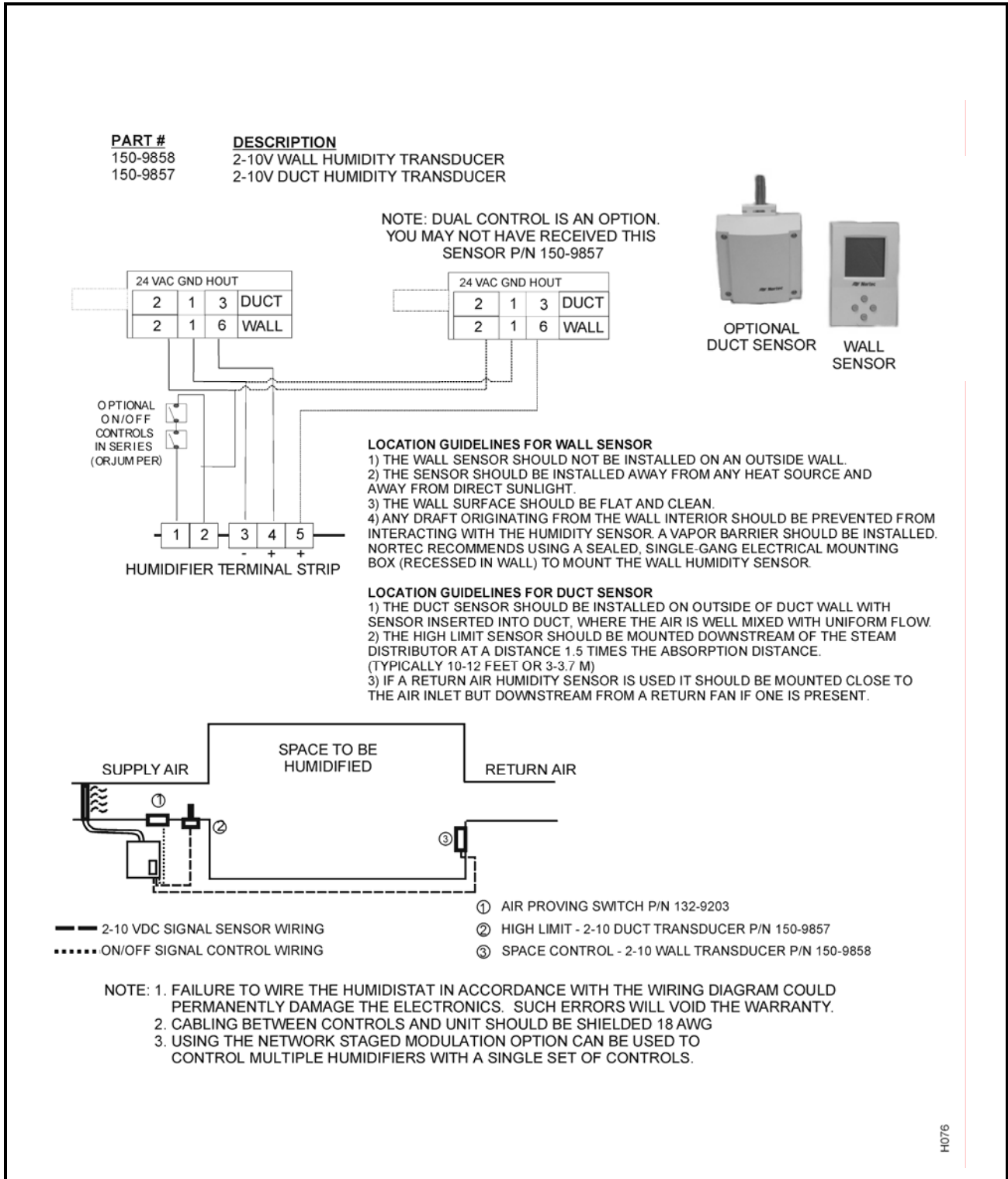
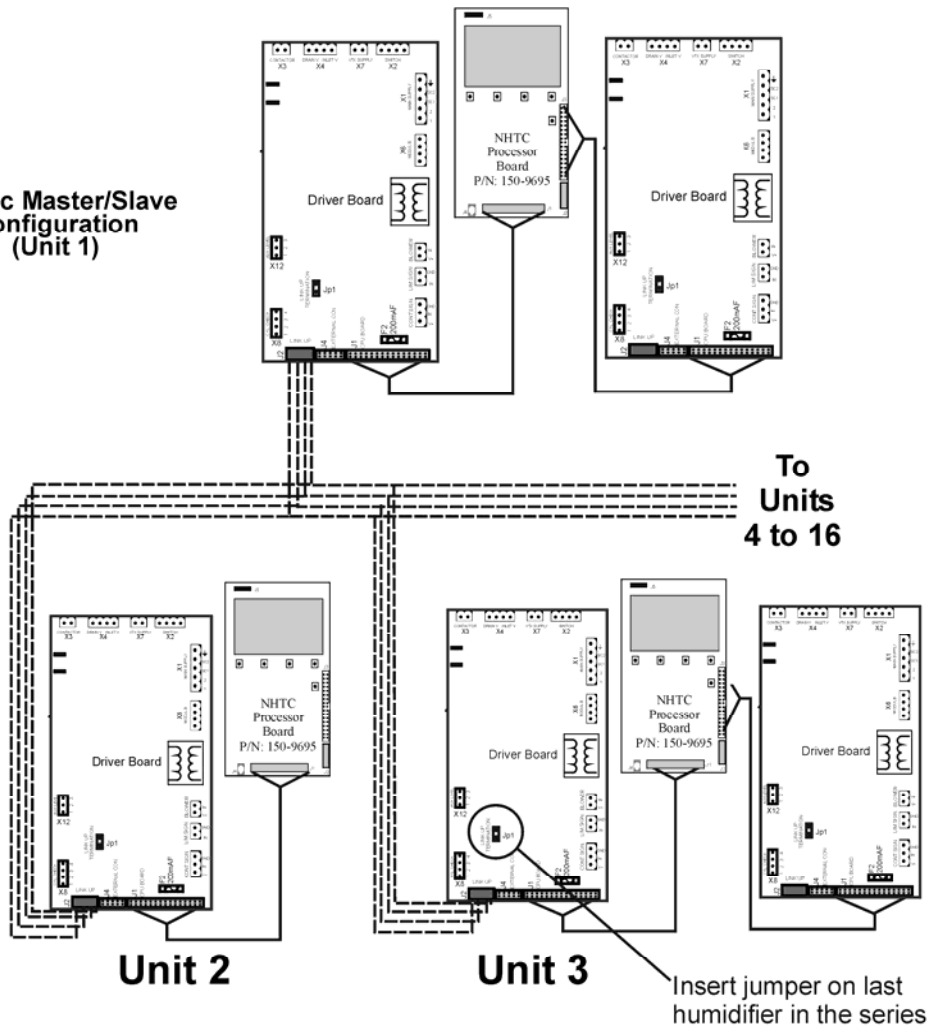

Figure 11. NORTEC Humidity Transducer Guidelines and Wiring (Optional)

H076

**Nortec Master/Slave Configuration (Unit 1)**

External wiring 'by others'  
- 18 to 24 AWG multi-strand  
- Twisted pair, shielded



To network up to sixteen (16) units (or equivalent of 1600 lbs/hr) using a Master Slave configuration, the units must be connected in parallel (daisy-chained) using the link up terminal (J2) on the driver board.

When connecting double units (NHTC 150 or 200) only driver board A need be connected. The final slave driver board must have the terminating jumper on "Link Up Termination" Jp1 indicating the end of the system.

H115

**Figure 12. Networking NHTCs (Optional)**



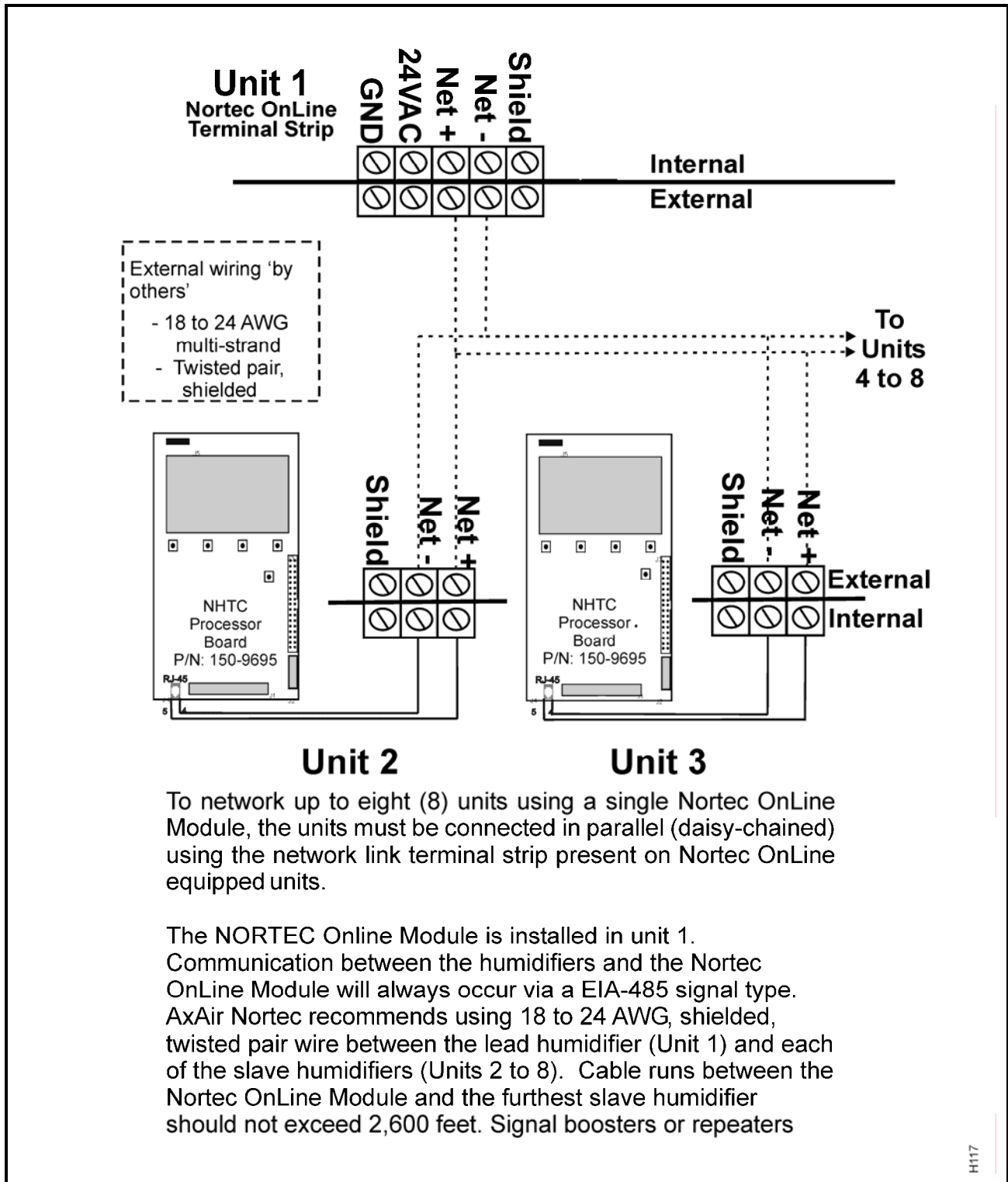

**Figure 13. NORTEC OnLine Installation Guidelines (Optional)**

# 10-20

# OPERATION

## 1. NHTC

### A. NHTC COMPONENTS

(1) Refer to Figures 1 and 2 when reading Table 1.

### B. HUMIDIFIER START-UP

(1) Figure 3 describes the method for powering up a humidifier and the cautions to take.

### C. BASIC STEAM PRODUCTION METHOD

(1) Figure 6 describes the method the NH Series humidifier uses to produce pure clean steam. The NORTEC NH electrode steam humidifier uses NORTEC's patented Auto-Adaptive cycle to calculate drains to maintain optimal performance. Figure 4 Drain Rate vs Water Conductivity depicts an indication of drain amounts.

### D. CYLINDER LIFE

(1) The output of all NH Series humidifiers is pure, clean steam; minerals originally in the incoming water are left behind. These minerals will eventually coat the cylinder electrodes. Therefore, the mineral content of the incoming water, the unit running time and output capacity setting ultimately determine cylinder life. NORTEC's cylinder life is up to 2,000 hours of operation. Water chemistry and capacity can affect cylinder life. (See Figure 5.) See Table 4 to identify the message which indicates when the cylinder is at the end of its life.

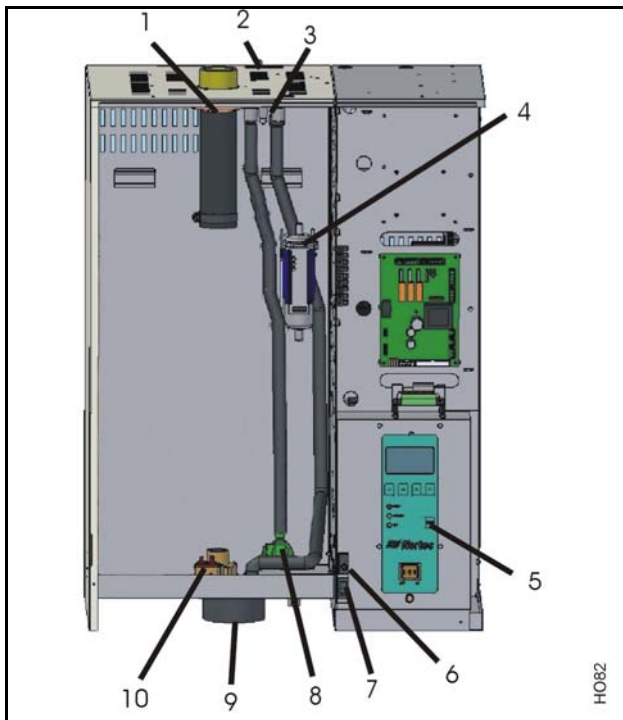

Figure 1. NHTC Components (Front View)

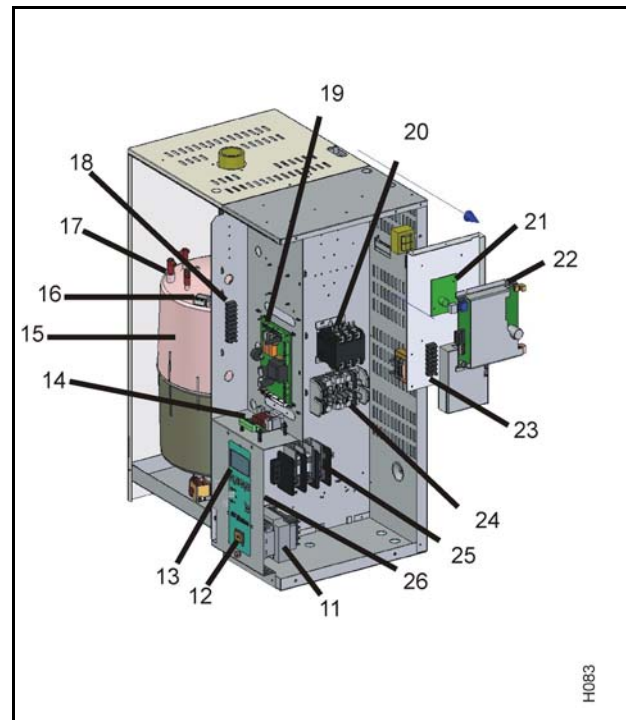

Figure 2. NHTC Components (Side View)

**Table 1. NHTC/NHPC Components**

Item Number	Component Name	Description
1	Steam Connector	Used to allow easy replacement of cylinders without disconnecting the steam line.
2	Condensate Return	This inlet is to return condensate to the unit.
3	Fill Cup	The fill cup allows isolation from the fill line by supplying an air gap. It will also overflow any water that cannot enter the cylinder to drain.
4	Float Chamber (Optional)	Detection OPTION – Used with the advanced foam detection setting.
5	Manual Drain Button	By pushing this button, manual drain is initiated with software support. Software support supplies drain cooling if enabled and will disable manual drain after 10 minutes.
6	Door Interlock	The door interlock prevents the unit from running when the front door is off. For startup and troubleshooting, pulling this interlock will override this safety feature.
7	Back-up Drain	Back-up drain switch allows the draining of the cylinder without electronic support.
8	Fill Valve	The fill valve allows water to flow up to the fill cup. In units with Drain Water Cooling to 120 degrees option, this valve is a dual valve. The second valve is wired in parallel with the drain valve to quench the water with fresh cold water everytime the drain is activated.
9	Drain Canal	The drain canal allows all drainable water to accumulate into one location to then be drained away.
10	Drain Valve	Drain valve when energized will allow water to flow down to the drain canal. When not energized, water flowing from the fill cup will flow up into the cylinder.
11	Transformer	The transformer converts the primary supply voltage to the required 24 VAC to the unit electronics. It is protected by a fuse to ensure that the 24 VAC electronics are protected from surges or shorts.
12	On/Off Switch	Turns the unit power on and off. Be aware that high voltage will still enter the unit even though the 24VAC electronic are disabled. The contactor will not be energized. Main shut-off should be open before any servicing is performed.
13	Graphical Display and Menu Buttons	The graphical display and buttons are used to navigate through the software. Use software flowchart as a reference.
14	Remote Relay Board (Optional)	The remote relay board is a set of 4 dry contacts, rated for 24 VAC 1A, which activate in conjunction with humidifier on, steam production, service and error conditions.
15	NORTEC Cylinder	The NORTEC disposable cylinder contains electrodes that become energized when the contactor is closed. This allows current to pass through the water from one electrode to another, generating heat within the water. The water then boils and the output is clean pure steam.

**Table 1. NHTC/NHPC Components (cont)**

Item Number	Component Name	Description
17	Cylinder Plug	Cylinder plugs are press fit on cylinder electrode pins. These color coded connections should fit snugly, on same color pins. Replace if loose or frayed.
18	Low Voltage Terminal Strip	The low voltage terminal strip is the location at which all controls are connected. See Installation for details.
19	Driver Board	The driver board(s) is the housing of all fuses and relays. It is connected to the total controller, and monitor and activate all humidifier states.
20	Contactors	The contactor(s) when energized allow main power to energize the cylinder electrodes, allowing current to pass, boiling the water.
21	NORTEC OnLine Module (Optional)	NORTEC ONLINE OPTION NHTC ONLY. This module allows the NHTC to be connected to the internet and communicate information to NORTEC via the internet. See NORTEC OnLine operation for details. NHTC only
22	Links Module (Optional)	NORTEC LINKS OPTION NHTC ONLY This module allows the NHTC to communicate with a BMS system using the communication protocol requested at order. See NORTEC Links operation for details. NHTC only
23	Network Terminal Strip	The network terminal strip allows up to 13 NHTC units to be connected on one Links module and eight OnLine modules. See Installation of NORTEC Links and OnLine for details on wiring humidifier networks.
24	Fuse Holder	OPTIONAL FUSE PACKAGE provides protection of individual high voltage lines in the humidifier and does not replace fuse and external disconnect.
25	High Voltage Terminal Strip	Connection point of main power lines to the humidifier from the underside of the strip. It is accompanied by a ground terminal which grounds the cabinet.
26	Total Controller	The total controller board (hidden in this view) is part of the graphical display. It is the microcomputer that sends and collects information from the driver boards, network modules and any other humidifier connected to it.

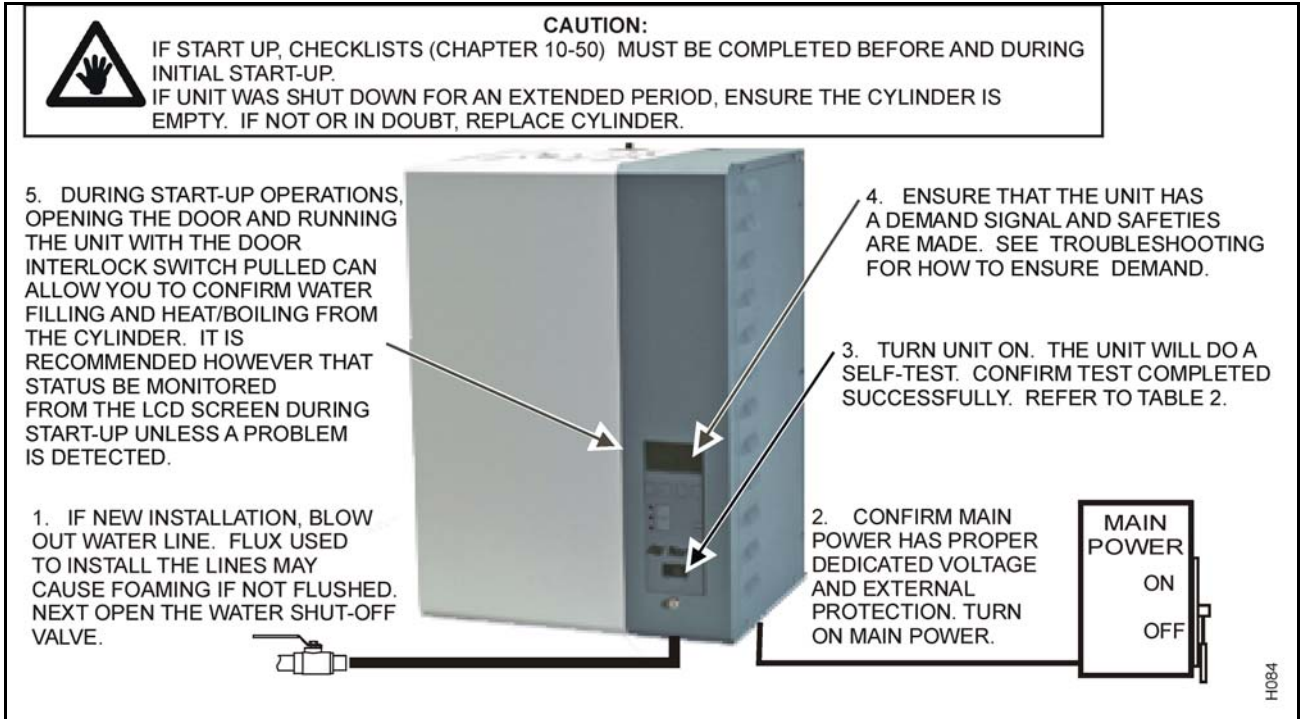

**Figure 3. Humidifier Start-Up**

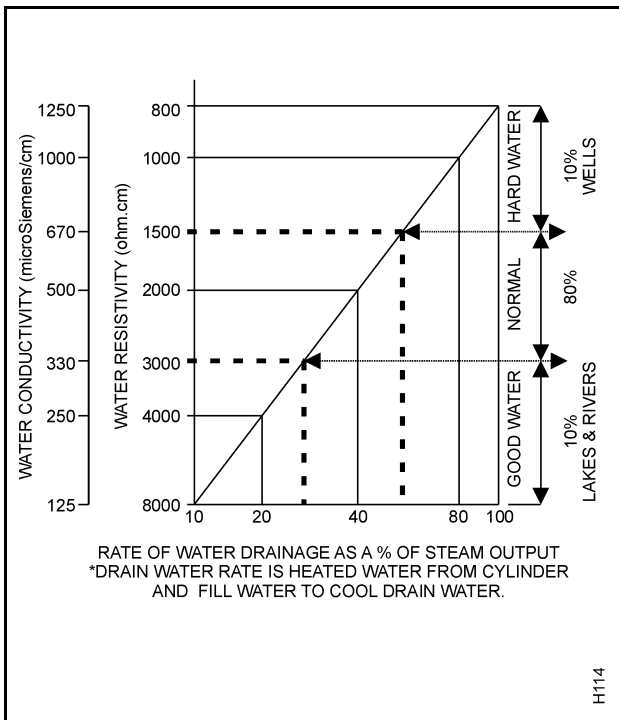

**Figure 4. Drain Rate Versus Water Conductivity**

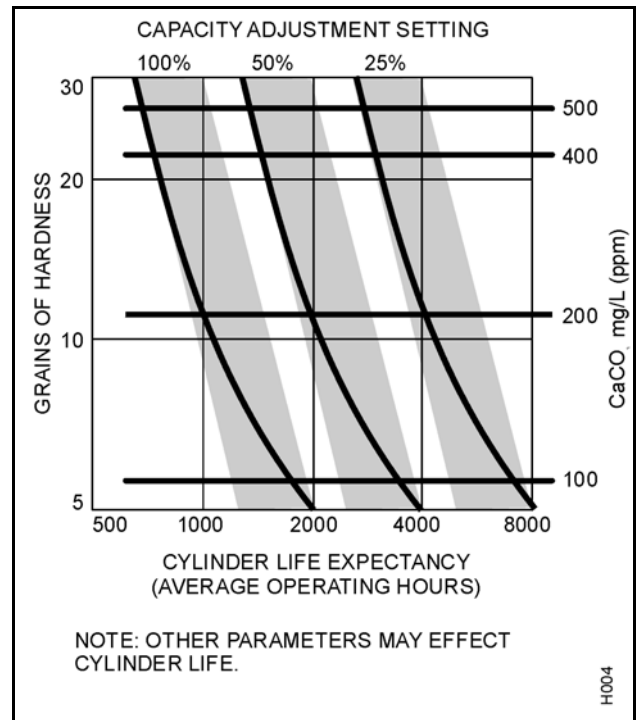

**Figure 5. Capacity Setting and Cylinder Life**

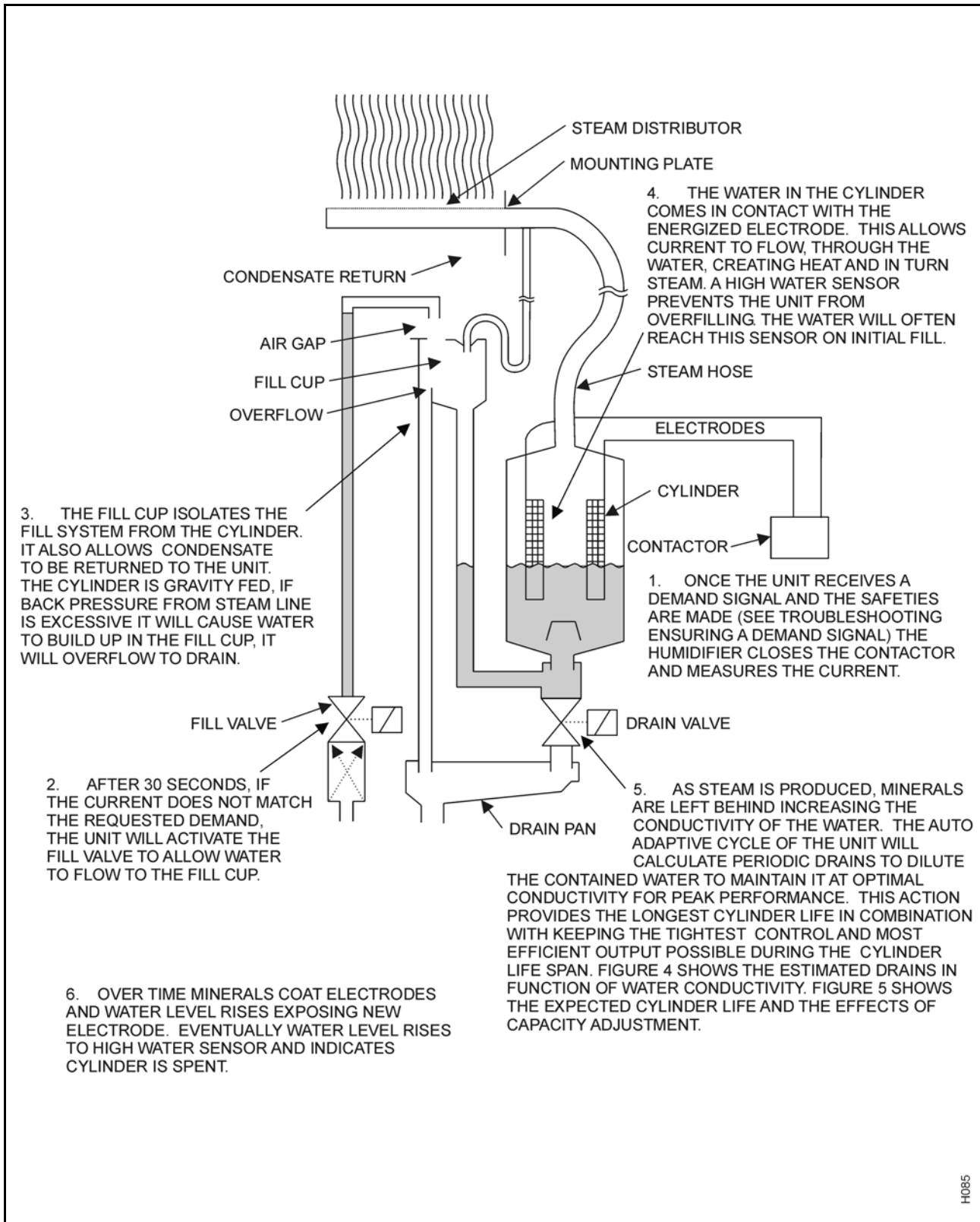

Figure 6. Basic Steam Production Method

## E. SOFTWARE INITIAL SELF-TEST

**Table 2. Self-Test Messages**

Graphic Display	Explanation/Comments (What You Read)
NHTC START-UP: INIT CYLINDER	The unit is beginning its bootup routine, along with powering up the EEPROM on the SMART Cylinder
NHTC START-UP: READING CYLINDER DATA	The unit reads the type of cylinder to provide maximum control of operation. If it unable to do so it will skip the rest of the self-test and fault out.
SELF TEST CYLINDER Inlet Valve ESC	Unit energizes the fill valve for 1 second.
SELF TEST CYLINDER Drain Valve ESC	Unit energizes the drain valve for 2 seconds.
SELF TEST CYLINDER Heat Cont. ESC	Unit closes the contactor for 2 seconds.
SELF TEST CYLINDER Pump ESC	Unit activates the pump (if present) for 2 seconds.
SELF TEST CYLINDER Bleed Valve ESC	Unit activates the bleed valve (if present) for 2 seconds.
SELF TEST REMOTE Steam Relay ESC	Unit activates the steam relay for remote fault indication package and green light.
SELF TEST REMOTE Service Relay ESC	Unit activates the service relay for remote fault indication package and yellow light.
SELF TEST REMOTE Error Relay ESC	Unit activates the error relay for remote fault indication package and red light.
SELF TEST REMOTE Oper. Relay ESC	Unit activates the unit on relay.

## F. SOFTWARE FLOW CHART WITH DEFINITIONS

- (1) The flow chart in Figure 7 depicts the software logic and definitions.

## G. SELF-HELP

- (1) The microcomputer applies corrective actions whenever its self-diagnostics identifies a problem that it is able to correct by itself. If the corrective action is not successful then it displays a system message. If the corrective action requires a service person, then the microcomputer's only resort is to stop the unit and display a system message. The unit never stops unless it has to.
- (2) After three days of no call from either the on/off controls or the modulating controls, when active, the three-day drain active feature is automatically activated long enough to drain all water from the steam cylinder. This NORTEC feature will prolong the life of the cylinder. (User selectable, default is ON.)



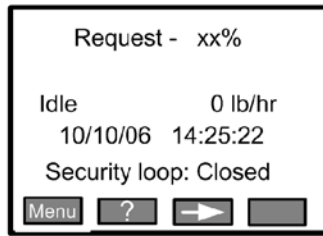

### Main Screen

This screen reports on request for humidity, current status, output of the unit, date and time (NHTC) and security loop status. If status is not idle or humidifying, the left arrow becomes a '?' which can give information on the status of the unit. Press menu to enter the Service Level. The arrows are used for navigation through screens.

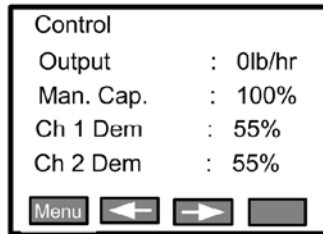

### Control Information Screen

Output refers to the output in lbs/hr of the unit. Man. Cap is the Manual Capacity limitation (see control settings). It also reports information on either one or both input channels depending on settings. If set to transducer control, also reports sensed rh.

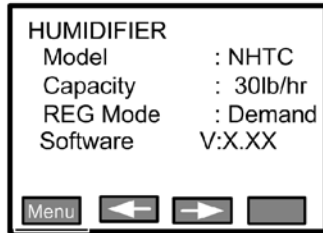
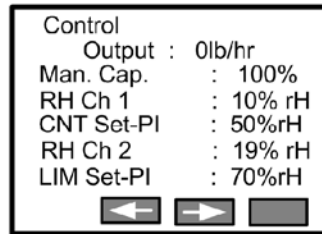

### Humidifier Information

Model is the humidifier model type, Capacity is its maximum output. REG Mode is the method by which it is controlled. Software Version is current installed software

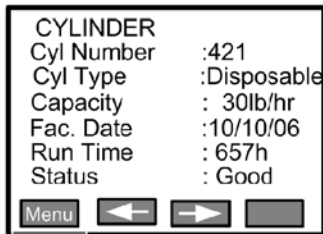
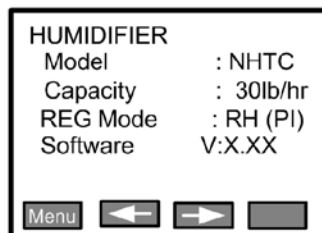

### Cylinder Information

Cyl Number is the identification number of the cylinder  
Cyl Type identifies its construction type  
Capacity shows its maximum rated capacity  
Fac. Date is the date it was manufactured  
Run Time is the amount of hours the cylinder has had current running through it in its lifetime  
Status indicates whether it is Good or Spent. If spent, replace.

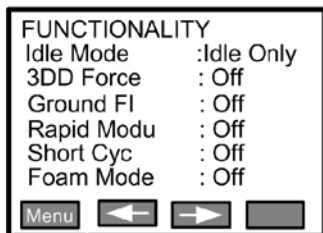

### Functionality Information

Indicated in this screen are whether or not specific settings are active and what state they are in. For definitions see each setting under User Defined Settings later in this figure.

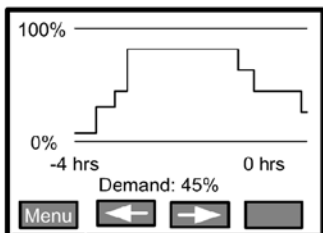

### Trend Graph

This simple graph gives a history of the output of the past four hours. It is a percentage of full output. It also indicates the current demand signal.

H086-1

Figure 7. Software Flow Chart (Sheet 1 of 7)

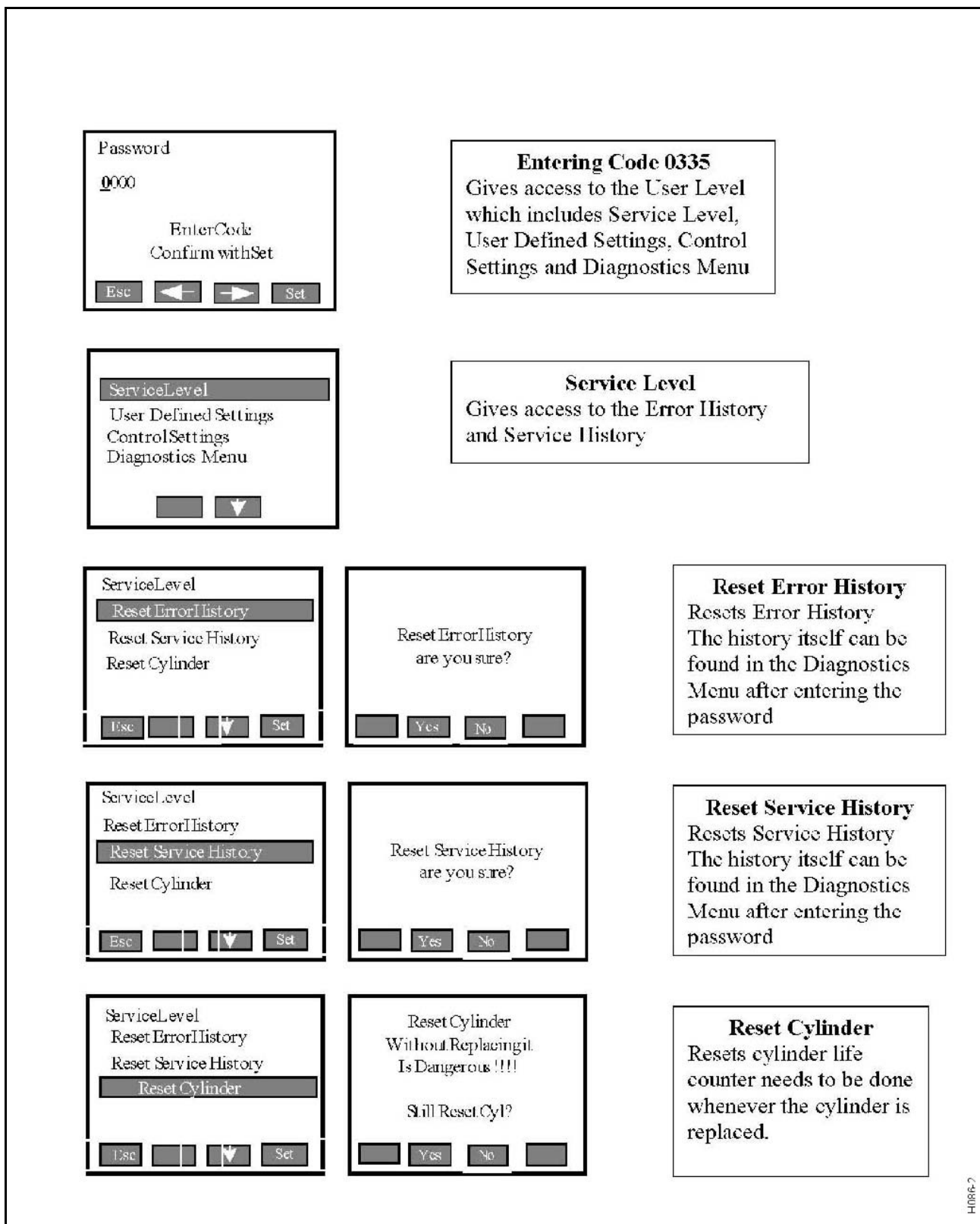

Figure 7. Software Flow Chart (Sheet 2 of 7)

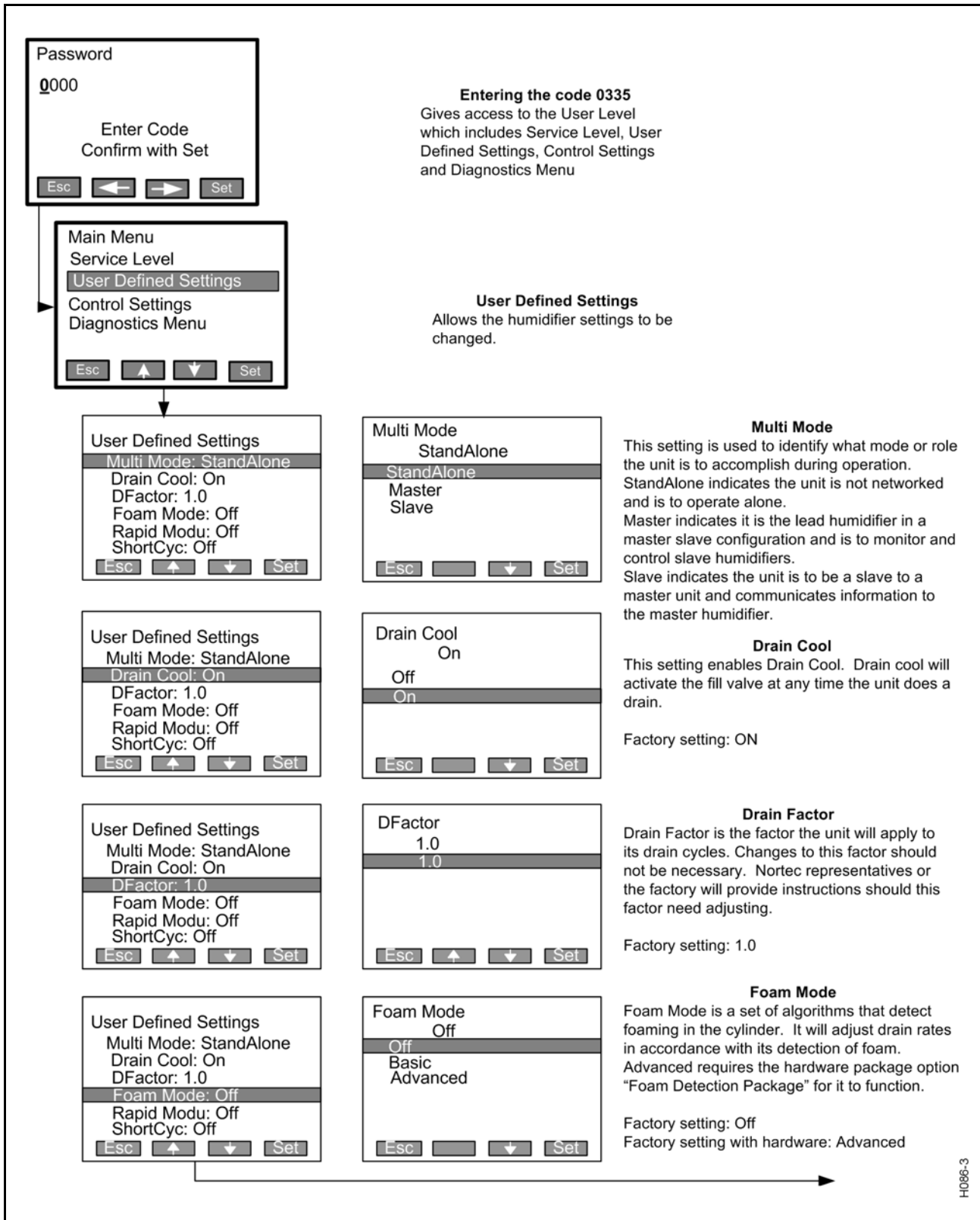

Figure 7. Software Flow Chart (Sheet 3 of 7)

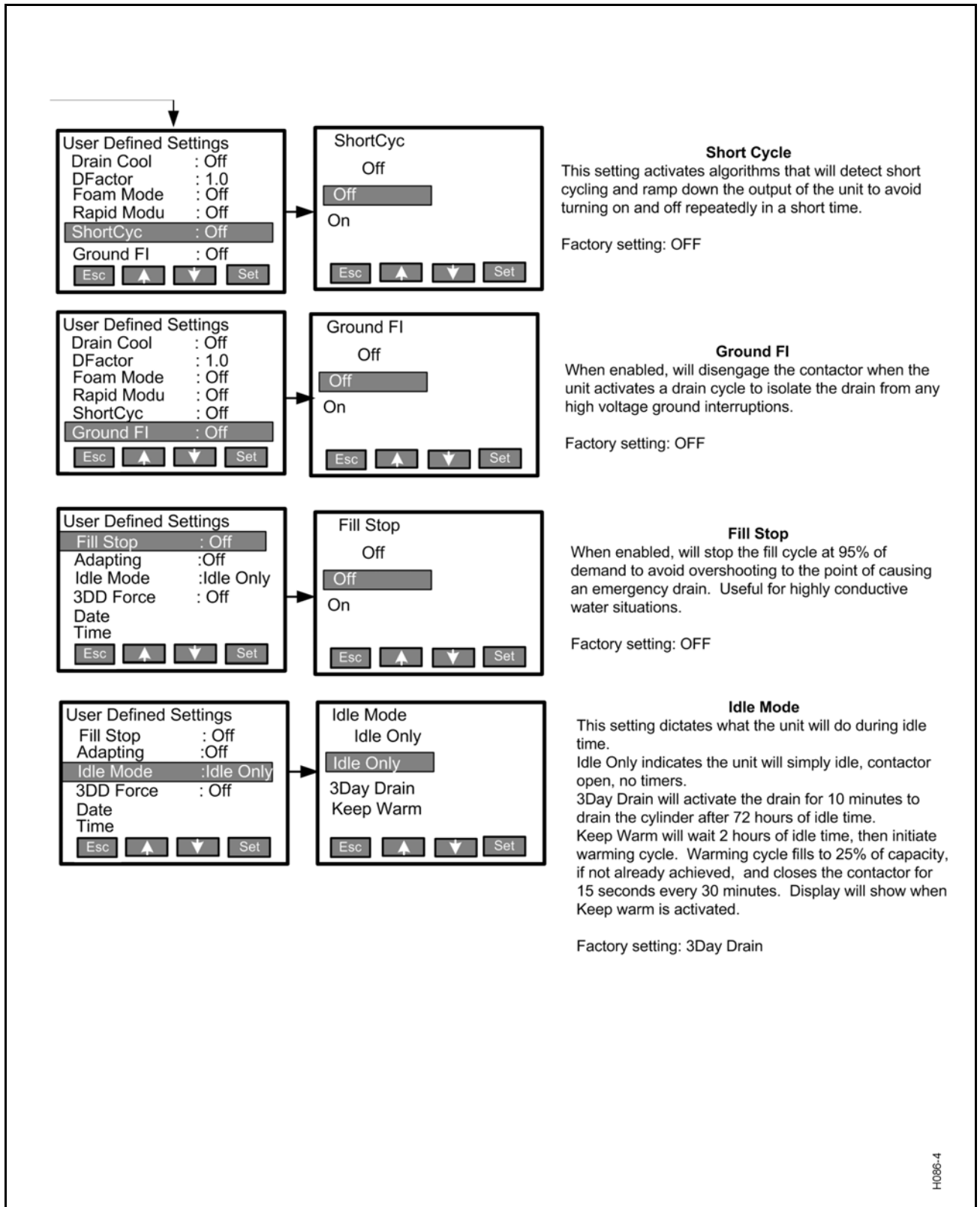

Figure 7. Software Flow Chart (Sheet 4 of 7)

```

User Defined Settings
Ground Fl: Off
Fill Stop: Off
Adapting: Off
Idle Mode: Idle Only
3DD Force: Off
Drain Mode: Fixed ED
Esc  ↑  ↓  Set
    
```

```

3DD Force
Off
Off
On
Esc  ↑  ↓  Set
    
```

**3DD Force**  
This setting activates the drain valve every 3 days regardless of demand or idle condition. Useful for water conditions that require additional purging due to sediment or other solid contaminants..

Factory setting: OFF

```

User Defined Settings
Ground Fl: Off
Fill Stop: Off
Adapting: Off
Idle Mode: Idle Only
3DD Force: Off
Drain Mode: Fixed ED
Esc  ↑  ↓  Set
    
```

```

Drain Mode: Fixed ED
Fixed ED
Fixed ED
Float ED
Esc  ↑  ↓  Set
    
```

**Drain Mode**  
Drain mode indicates to the unit the function of the emergency drain.  
Fixed ED will cause emergency drains at 115% of full load regardless of demand.  
Float ED will cause emergency drains at 115% amp draw of current demand on the unit.

Factory setting: Fixed ED

```

User Defined Settings
Drain Mode: Fixed ED
Overcurr.: 0.00
Date
Time
Unit
Language: English
Esc  ↑  ↓  Set
    
```

```

Overcurr.
0.00
0.00
Esc  ↑  ↓  Set
    
```

**Overcurr.**  
Factory parameter to be adjusted only by request of the factory.

Factory setting: 0.00

```

User Defined Settings
Drain Mode: Fixed ED
Overcurr.: 0.00
Date
Time
Unit
Language: English
Esc  ↑  ↓  Set
    
```

```

Date
Day
Month
Year
Esc  ↓  Set
    
```

**Date**  
Sets Date  
Factory setting: The day before tomorrow

```

User Defined Settings
Drain Mode: Fixed ED
Overcurr.: 0.00
Date
Time
Unit
Language: English
Esc  ↑  ↓  Set
    
```

```

Time
Hour
Minute
Esc  ↓  Set
    
```

**Time**  
Sets local time  
Factory setting: Eastern Standard Time

```

User Defined Settings
Drain Mode: Fixed ED
Overcurr.: 0.00
Date
Time
Unit
Language: English
Esc  ↑  ↓  Set
    
```

```

Unit
LB/hr
kg/hr
Lb/hr
Esc  ↑  ↓  Set
    
```

**Unit Steam**  
Sets the units in which the humidifier will display output.  
Factory setting: lb/hr

```

User Defined Settings
Drain Mode: Fixed ED
Overcurr.: 0.00
Date
Time
Unit
Language: English
Esc  ↑  ↓  Set
    
```

```

Language
English
English
French
Esc  ↑  ↓  Set
    
```

**Language**  
Sets the language in which the humidifier will display its information.  
Factory setting: English or by request.

H086-5

Figure 7. Software Flow Chart (Sheet 5 of 7)

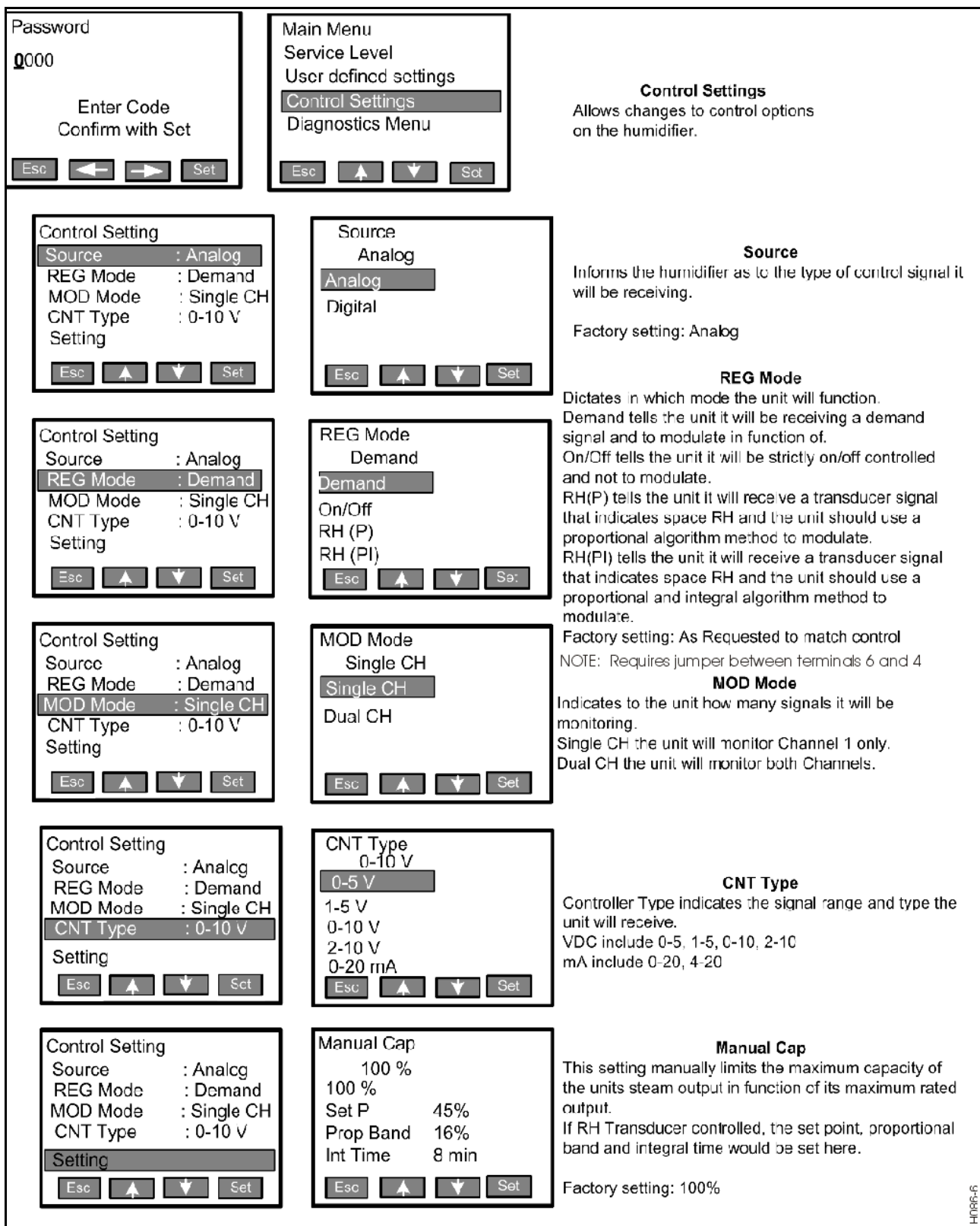

Figure 7. Software Flow Chart (Sheet 6 of 7)

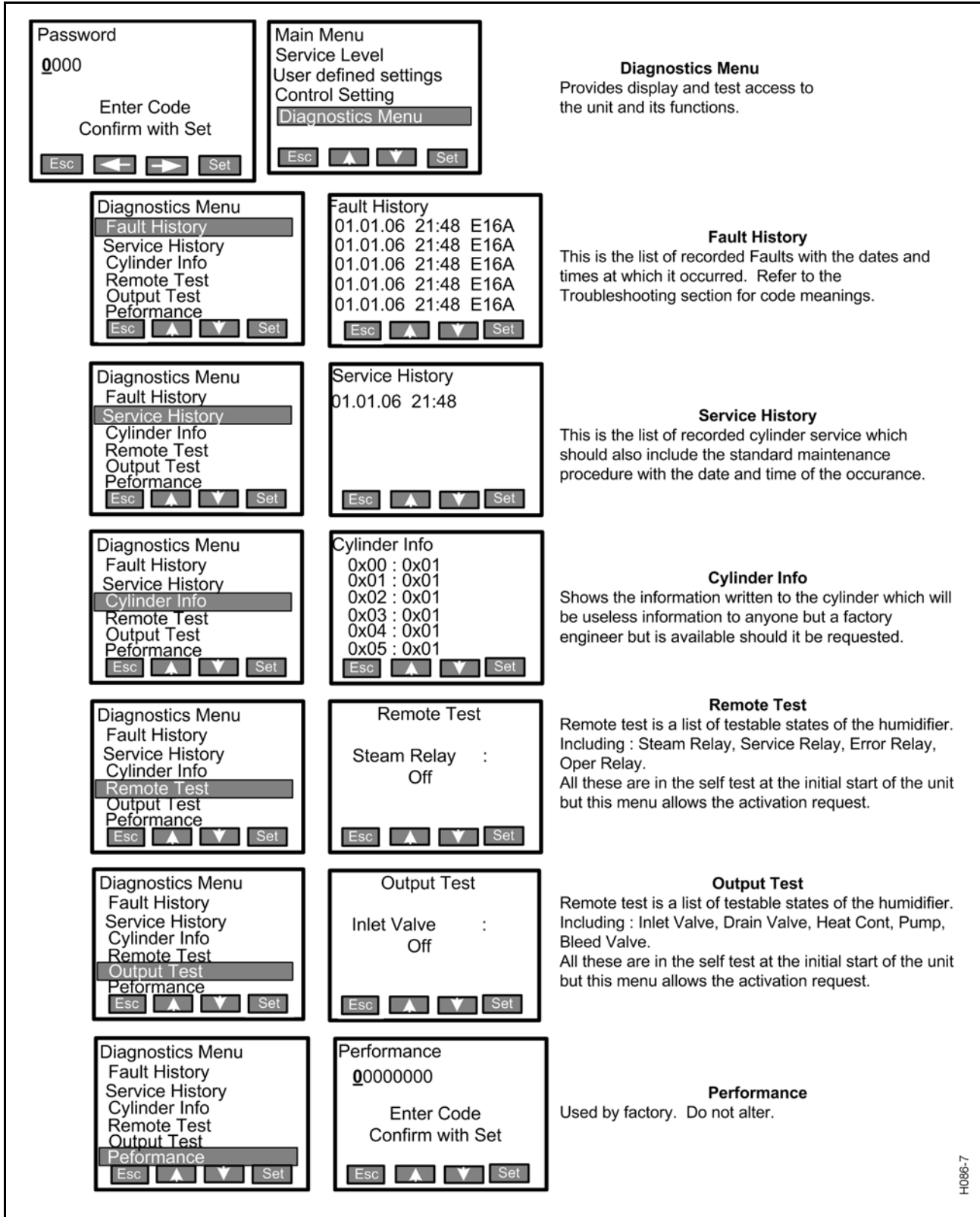

Figure 7. Software Flow Chart (Sheet 7 of 7)

## H. SYSTEM MESSAGES AND LIGHTS

- (1) Table 3 describes general signal light status meanings.

**Table 3. Signal Light Status**

Yellow	Green	Red	
OFF	OFF	OFF	Unit is on standby or humidifier has just been energized but has not sensed production of steam yet.
OFF	ON	OFF	Humidifier senses production of steam.
ON	OFF	OFF	An attention state exists that should not prevent the unit from producing steam when the controls call for it. Check the message on the screen to try to correct it.
ON	ON	OFF	Prepare to replace cylinder or normal startup operation. May also indicate an attention during operation. Check the message on the screen to try to correct it.
BLINK	OFF	OFF	Manual Drain On with software drain switch.
OFF	BLINK	OFF	Unit sees a demand, but safeties are open.
OFF	OFF	ON	Operation fault (unit will not run).

- (2) Table 4 describes common status messages and the lights displayed for each and their meaning. For a list of warnings and faults, see Chapter 10-40 Troubleshooting.

## I. DOUBLE UNIT OPERATION

- (1) The unit will report only one cylinder at a time if the unit was ordered without coupled circuits. You will notice on the screen the indication of which cylinder you are monitoring and in the lower right the option to monitor the alternate cylinder.



**Table 4. Status Messages with LED State**

NHTC Display Message	LED state	System Action
Idle	None	Unit is made idle.
Humidifying	GRN (after steam production starts)	The unit has closed the contactor and is sending current to the cylinder to humidify.
MANUAL DRAIN: ON	YEL (blink)	The drain valve is activated.
SAFETY LOOP; OPEN	GRN (blink)	Steam production stopped.
LEVEL SENSOR; ON	None	Deactivates the fill valve to prevent overfilling.
KEEP WARM ACTIVATED	None	Keep Warm feature activated, it has closed the contactor to warm the water.
W19: Cylinder spent	YEL, GRN	The electronics allow the cylinder to be reset up to four times before locking out the humidifier.
E19: Cylinder spent	YEL, RED	Humidifier interrupts operation and the fault relay is activated.
FOAM: FULL TANK FLUSHING	None	The unit will initiate a flush of the cylinder and resume operation.

Symptom Diagnosed	Probable Cause	Corrective Action
Unit is awaiting a demand or control signal.	This is normal when there is no need for humidity. If you believe there is a need for humidity, and the unit should not be idle, refer to troubleshooting	Normal Operation
The unit is now boiling water in the cylinder and filling as necessary.	This is normal when there is a need for humidity. If you believe there is no need for humidity, and the unit should idle, refer to troubleshooting	Normal Operation
This is not a fault or warning. It is an indication that the manual drain switch has been activated.	Manual drain switch has been activated.	Press Manual Drain button again to stop the drain action.
Safety loop circuit (terminal 1 and 2) is open.	One or more of the safety devices is open as the result of a device failure, improper installation or an unsafe condition has been detected.	Determine which device is preventing continuity of the safety loop circuit, and verify that it is functioning properly and is properly installed and calibrated.
Water has reached the top of the cylinder and has activated the high water sensor. This is not an error or fault, but is normal on start-up and at the end of a cylinder life span.	<ol style="list-style-type: none"> <li>1. Normal on start-up with a new cylinder or a cylinder that has been completely drained because of an extended off period. This condition can last several hours until the water in the cylinder has concentrated or the electrodes can no longer provide rated capacity or adjusted capacity. Water level automatically rises to meet the demand.</li> <li>2. Foaming can also cause an invalid high water indication.</li> </ol>	If foaming is determined to be the cause of the high water indication, consult your local representative about possible adjustment and/or a foam detection kit. If not foaming, consider it normal operation unless water level is not at the top of the cylinder.
Keep Warm feature is enabled and proceeding to a Keep Warm Cycle.	Unit is entering the Keep Warm cycle. The unit has been inactive for a given period and is keeping the water warm.	Normal for unit with Keep Warm setting activated.
Electronics have determined cylinder is spent. Within the next 72 hours the humidifier will stop.	The cylinder must be replaced with the same type and model.	When ordering a new cylinder, quote the model number presently installed in the humidifier.
Electronics have determined that the cylinder is spent.	The cylinder must be replaced with the same type and model.	When ordering a new cylinder, quote the model number presently installed in the humidifier.
The electronics has detected foaming within the cylinder (only for units with the optional Foam Detection Package).	The unit has detected a foaming condition within the cylinder.	The unit will initiate corrective action on its own.

## 2. STEAM DISTRIBUTION

### A. STEAM DISTRIBUTOR OPERATION

- (1) Figure 8 describes the method by which the steam distributor releases pure clean steam into the duct while collecting condensate and removing it by the condensate return.

### B. SAM-e OPERATION

- (1) Figure 9 describes the method by which the Short Absorption Manifold releases pure clean steam into the duct while collecting condensate, removing it by condensate return and ensuring short absorption distance.

### C. BLOWER PACK OPERATION

#### WARNING



**DURING AND FOLLOWING OPERATION OF THE HUMIDIFIER, THE STEAM AND COMPONENTS IN CONTACT WITH THE STEAM ON THE BLOWER PACK CAN BECOME HOT AND CAN BURN IF TOUCHED.**

- (1) Figure 10 describes the method by which the blower pack distributes the pure clean steam directly into the space required. It also describes the adjustments that can be made to conform to the specific situation.

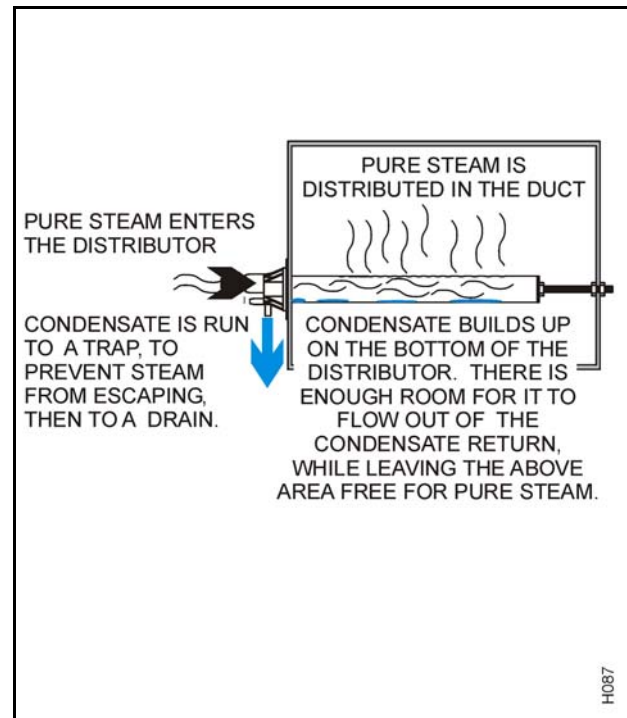
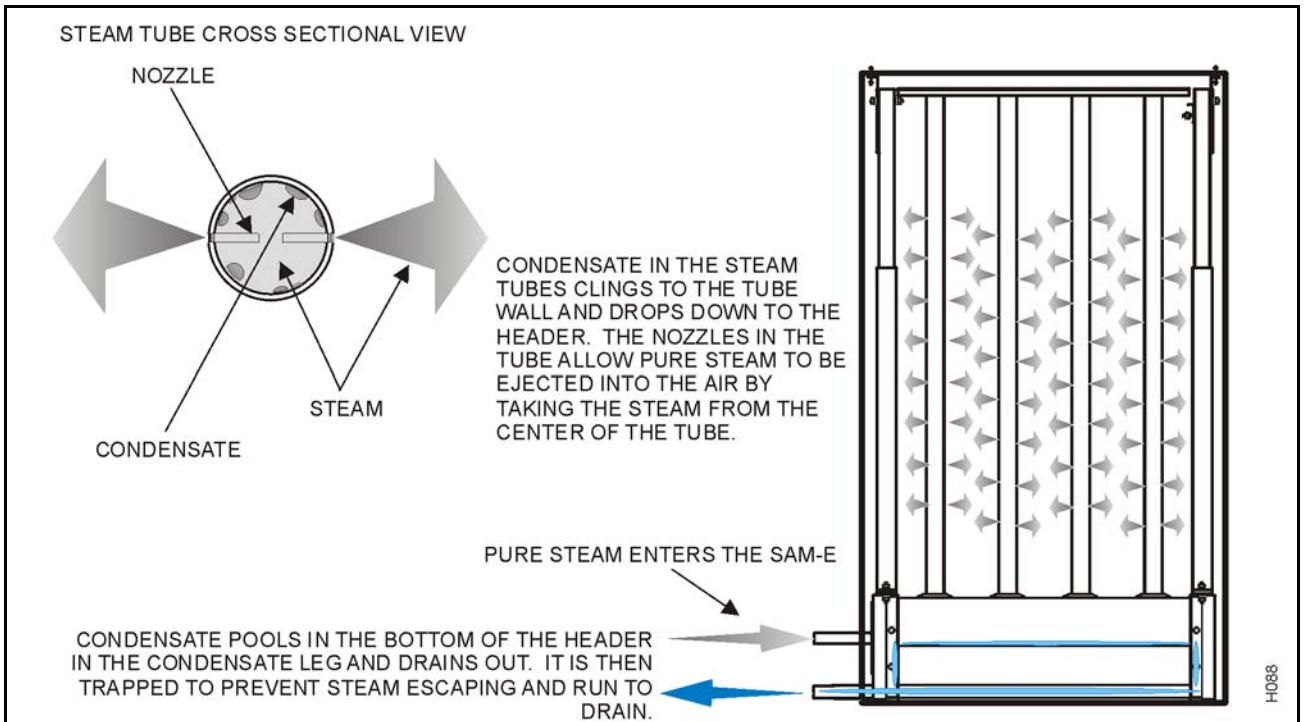
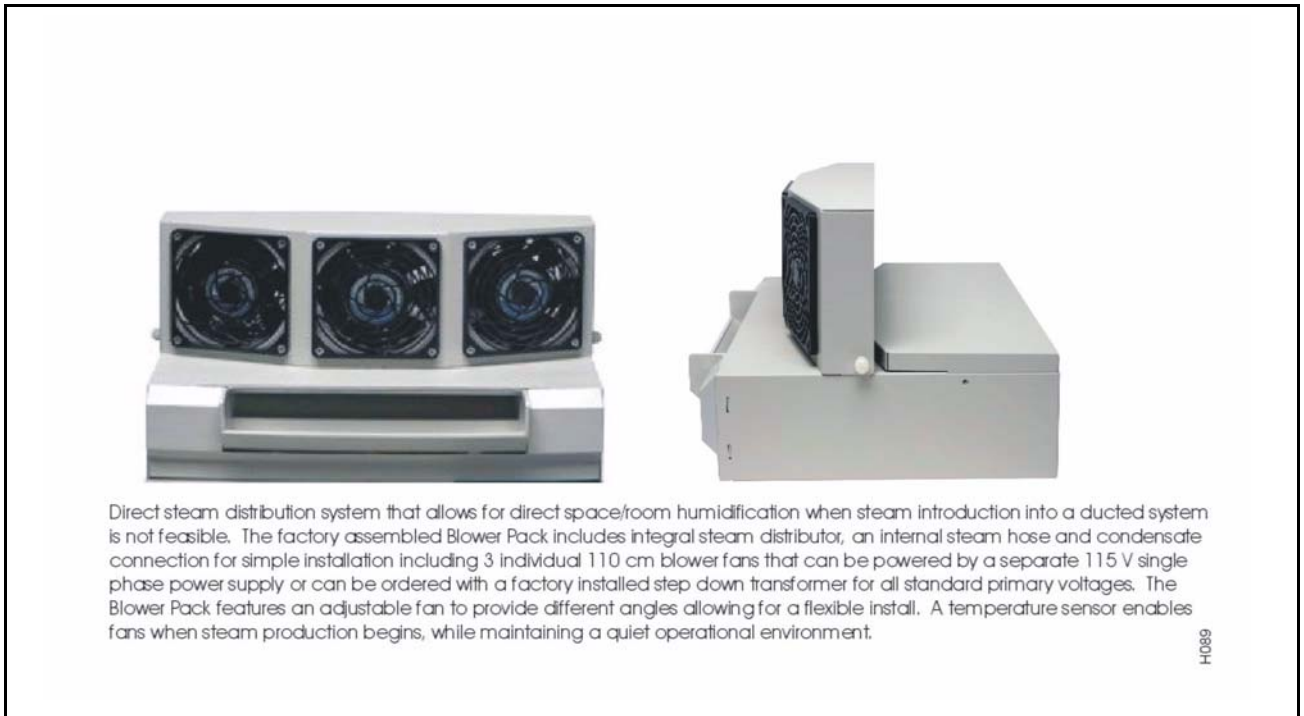

Figure 8. Steam Distributor Operation



**Figure 9. SAM-e Operation**



**Figure 10. Blower Pack Operation and Adjustments**

### 3. CONTROLS AND REMOTE COMMUNICATION (OPTIONAL)

#### A. DIGITAL CONTROL OPERATION

- (1) Figure 11 shows the components of the NORTEC Controller and how to adjust the setpoint.
- (2) In the case of a modulating NORTEC Controller, Figure 12 shows the relation between the difference from setpoint to %rh in the room and the 0-10 V DC demand signal sent out. From this basis the NORTEC Controller uses its PI algorithm to adjust its demand signal in accordance with the history of the environment. This type of control allows for tighter and more precise control.

#### B. DIGITAL TRANSDUCER OPERATION

- (1) The NORTEC digital transducers, shown in Figure 13, are designed to sense humidity in duct or in room respectively, and report it back to a controller or the NHTC directly. Required humidifier output is determined by controller or humidifier.

#### C. REMOTE CONNECTIONS (OPTIONAL)



#### CAUTION

**NORTEC DOES NOT RECOMMEND USING THE DRY RELAY CONTACTS WITH ANYTHING MORE THAN 24 VAC, 1 AMP.**

- (1) The NHTC reports the signal light status, in Table 3, by closing the supplied dry contact relays which can be wired back to a BMS or monitoring station. This method of monitoring is not as informative as the actual display, but alerts you to the general status of the unit.

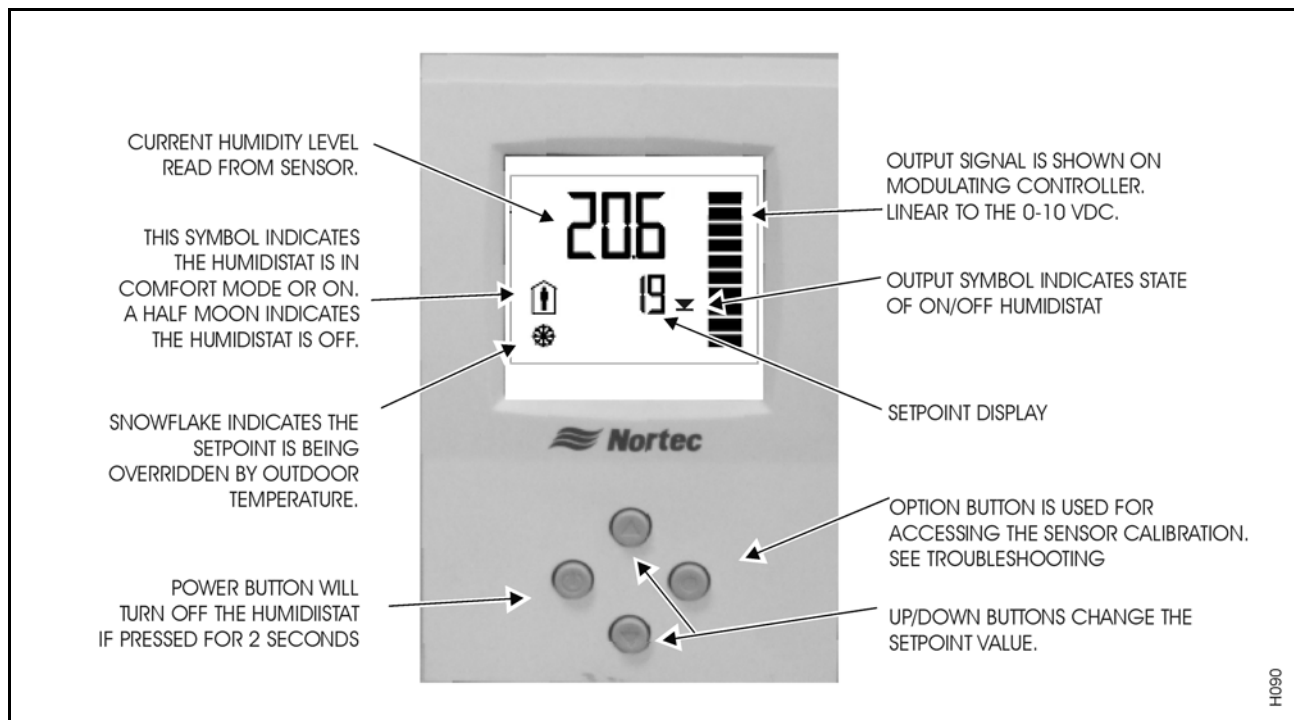

**Figure 11. NORTEC Digital Controller**

#### D. NORTEC LINKS 2 OPERATION

- (1) NORTEC LINKS 2 is an option that can be integrated with the NHTC. This allows a BMS to monitor and in the right configuration, control the humidifier. For additional information about NORTEC Links and its operation and configuration, go to [www.humidity.com](http://www.humidity.com) and look up the NORTEC LINKS 2 manual.
- (2) Table 5 contains a list of NORTEC LINKS 2 variable definitions. For a complete list, contact the factory.

#### E. NORTEC ONLINE OPERATION

- (1) NORTEC OnLine is an option that can be integrated with the NHTC. This allows a user to log onto the internet, go to [www.norteconline.com](http://www.norteconline.com) and log in to allow them to monitor their unit from any computer with an internet connection. (See Figure 14)
- (2) After initially logging into the NORTEC OnLine server the user will be presented with a list of humidifiers currently registered with the Server program. Each humidifier will be listed with a unit type identifier, a serial number and an address descriptor.
- (3) By clicking on the humidifier name, the user will then be brought to a status screen with an image of the selected humidifier.
- (4) Figure 14 shows a typical NORTEC OnLine Monitoring Screen. Use this manual in combination with NORTEC OnLine to be able to monitor and understand the settings possible through the NORTEC OnLine Interface.

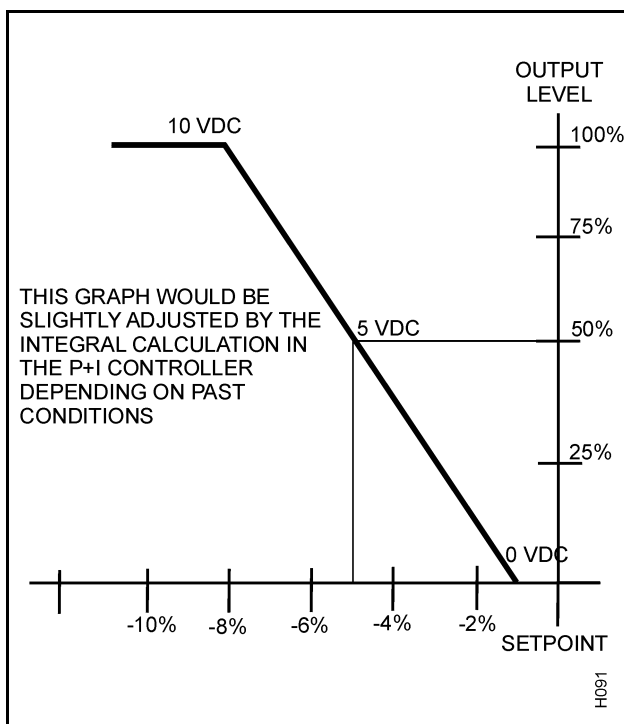

**Figure 12. Difference from Setpoint in Relation to Demand Signal**

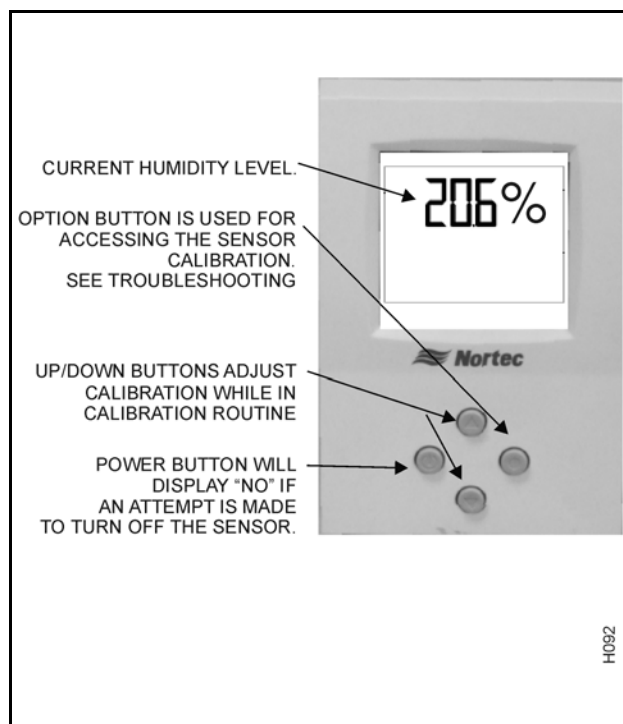

**Figure 13. Duct and Wall Mounted Transducer**

**THIS PAGE INTENTIONALLY LEFT BLANK**

**10-30**

**MAINTENANCE  
PROCEDURES**

**10-30**

**Page 49**

**2008-08-28**



## MAINTENANCE PROCEDURES

### 1. NH ELECTRODE STEAM HUMIDIFIERS



Typical tools required for any maintenance procedure:

- Slotted Screwdriver
- Small Slotted Screwdriver
- Phillips Screwdriver
- Needle-Nose Pliers
- Wrench

#### A. MAINTENANCE



#### WARNING

**DISCONNECT MAIN POWER BEFORE ANY SERVICING.**



#### WARNING

**THE PLUMBING AND ELECTRICAL COMPARTMENTS CONTAIN HIGH VOLTAGE COMPONENTS AND WIRING. ACCESS SHOULD BE LIMITED TO AUTHORIZED PERSONNEL ONLY.**

- (1) The NHTC and its components are a very low maintenance system. The only maintenance normally required is to change the cylinder, clean out the drain valve assembly, clean out the inlet valve screen and know the procedure for extended shut-down and start-up.

#### B. WHEN TO REPLACE THE STEAM CYLINDER

- (1) The steam cylinder is disposable and must be replaced at end of cylinder life. Cylinder life is dependent on water supply conditions and humidifier usage. Failure to replace the cylinder at the end of cylinder life will cause the unit to lock out. NORTEC is not responsible for any damages resulting from, or attributed to, the failure to replace a spent cylinder (see Manufacturer's Warranty). There are many indications, each of which signifies the end of cylinder life. See 10-20 Operation, Table 4, for details on how the unit functions and determines end of cylinder life.

#### C. EXTENDED SHUT-DOWN

- (1) As long as the NHTC is powered, it will automatically drain the cylinder when there has not been a call for humidity for an extended period of time. This feature will reduce or prevent the possibility of corrosion of the electrodes and the accumulation of algae and bacteria growing in the cylinder. The cylinder will remain empty until there is a call for humidity at which time the fill valve will open and refill the cylinder. The unit will go through its normal process for optimum operation.
- (2) Should it be required to disconnect power to the humidifier for a period of extended shut-down, **always drain** the cylinder first. Leave the switch in the OFF position and 'open' the main external fused disconnect to stop power to the humidifier. Close the shut-off valve in the water supply line feeding the humidifier.

## D. COMPONENTS OF THE STEAM CYLINDER

(1) Consult Figure 1 for NORTEC cylinder components.

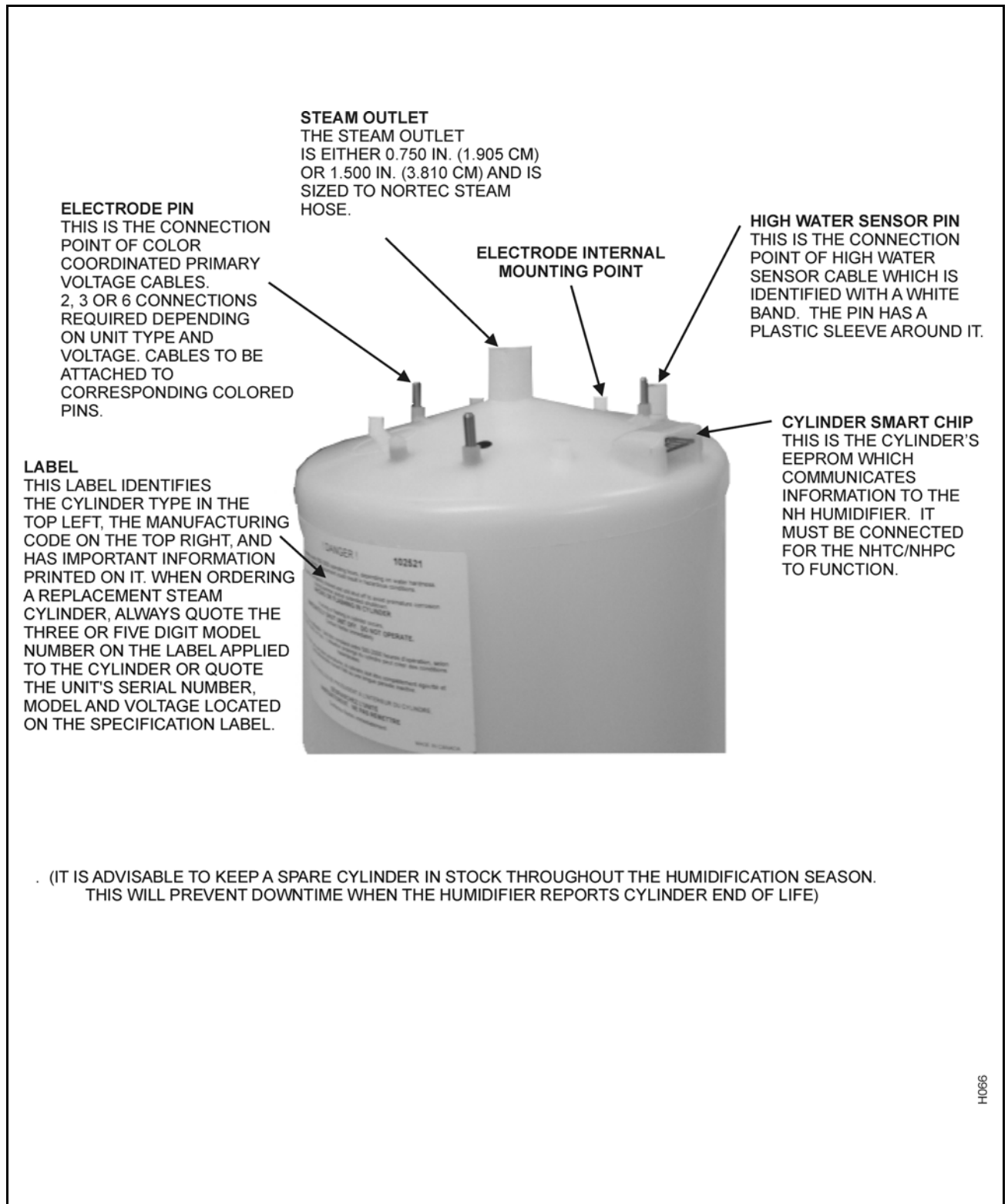
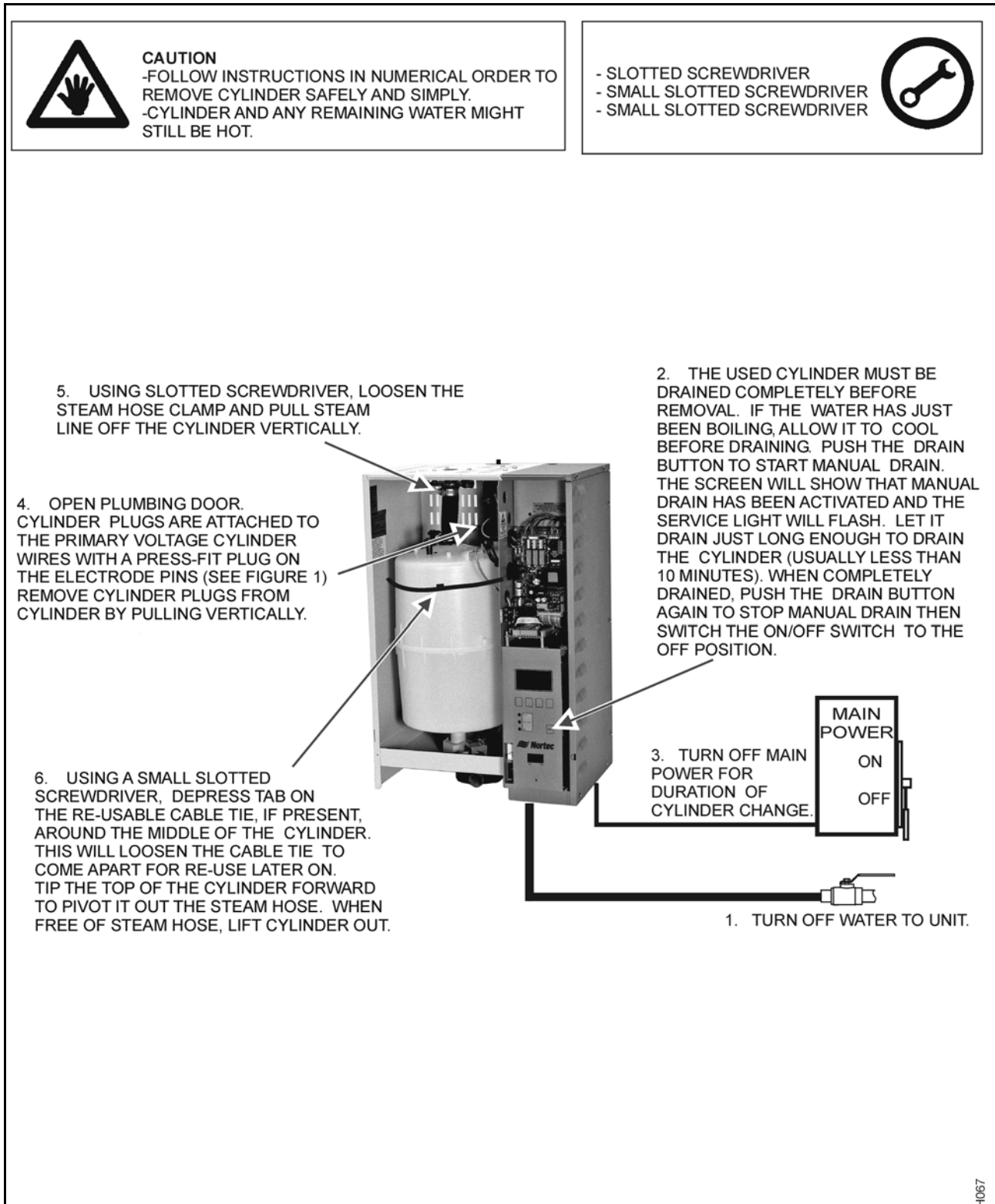

Figure 1. Cylinder Components

## E. HOW TO REMOVE THE STEAM CYLINDER

(1) Consult Figure 2 for removal of the steam cylinder.



## F. MANDATORY CLEANING OF THE DRAIN VALVE

- (1) Always clean the drain valve before installing a new cylinder since the valve port may be as dirty as the used cylinder. Figure 3 describes the process of removing and cleaning the drain valve. Perform paragraph E. before proceeding.

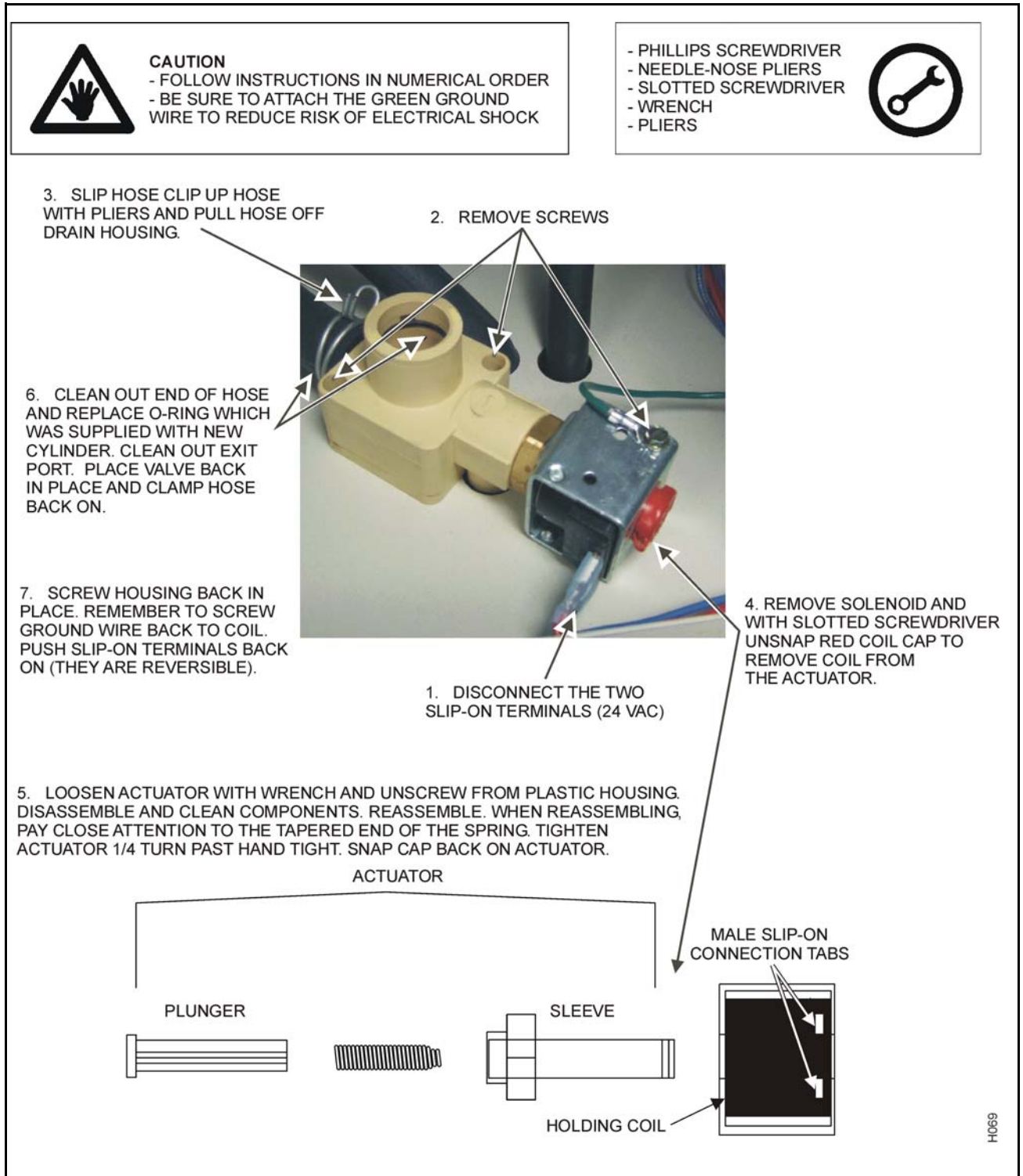

**Figure 3. Drain Valve Maintenance**

## G. HOW TO INSTALL THE REPLACEMENT CYLINDER

(1) Consult Figure 4 to install the replacement cylinder.

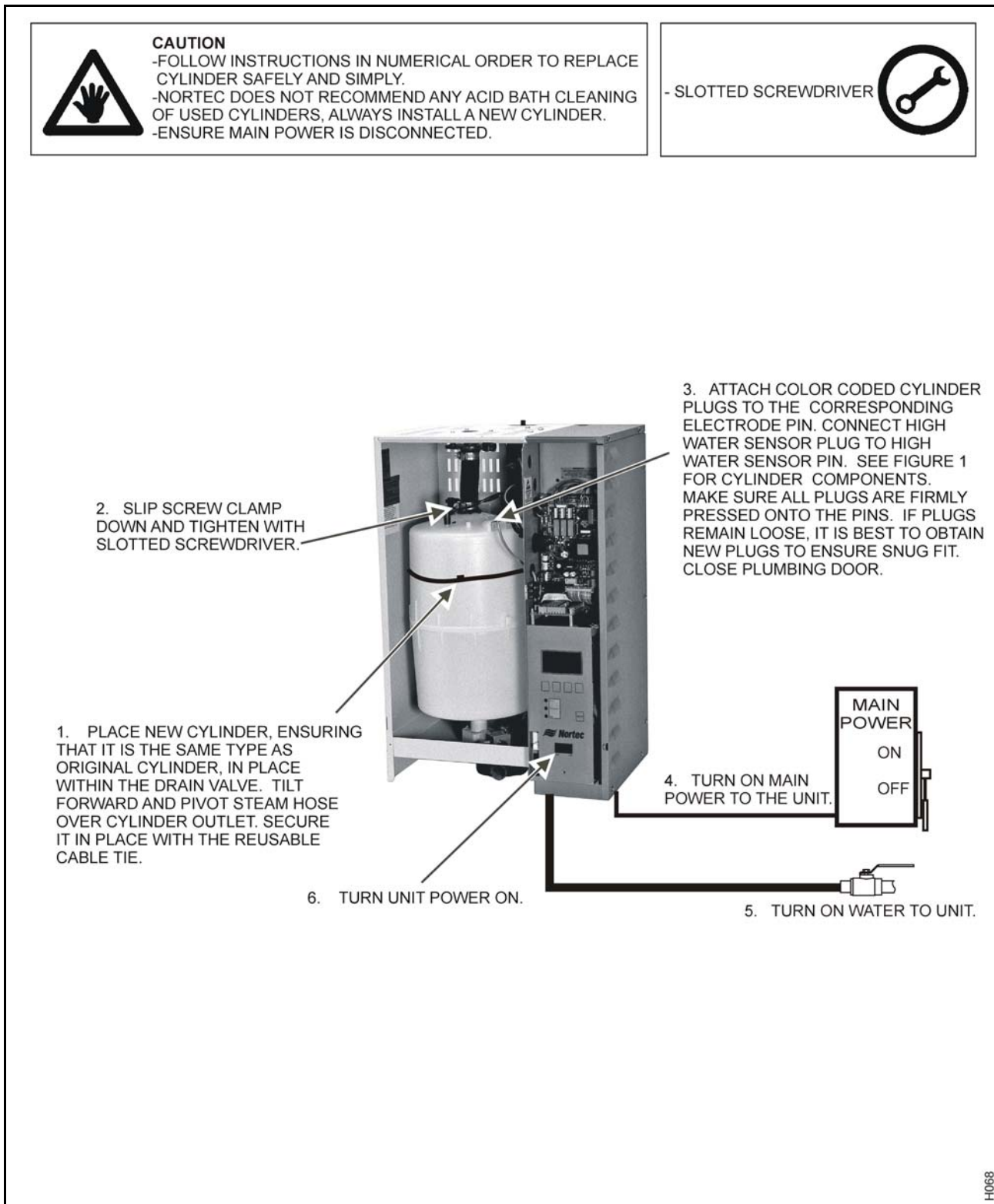

Figure 4. Cylinder Replacement Procedure

**10-40**

# **TROUBLESHOOTING**

**10-40**

**Page 55**

**2008-08-28**

## 1. TROUBLESHOOTING NH ELECTRODE STEAM HUMIDIFIERS

### A. PREPARATION

- (1) Ensure the installation detail conform to installation requirements.
- (2) Understanding the Principle of Operation and the software menus is an asset when troubleshooting. This information is found in chapter 10-20 Operation and can be elaborated on by your local representative.
- (3) When contacting your local representative or NORTEC for troubleshooting assistance, please ensure the serial number has been obtained for reference purposes.
- (4) Whenever the troubleshooting steps indicate a problem with the main pc-board, first check all connections at the main PCB (including the ribbon cable connections at the center of the main PCB) before ordering replacements.

### B. STARTING POINT

- (1) Table 1 checkpoints will allow for faster troubleshooting. Ensuring that all these steps are taken is good practice when beginning to troubleshoot the NH series humidifier. Check your symptom and verify all points before ordering any replacement parts or contacting your local representative. Use the wiring diagram when necessary for clarification.

#### NOTE

Wiring diagrams on unit supersedes diagrams in this manual.

#### WARNING



**BE AWARE, WHEN TROUBLESHOOTING, THAT THE HUMIDIFIER IS POWERED BY HIGH VOLTAGE AND FAMILIARITY WITH BOTH GOOD PRACTICES AND WIRING OF THE HUMIDIFIER IS RECOMMENDED. ANY TROUBLESHOOTING THAT REQUIRES OPENING THE CABINET SHOULD BE DONE BY QUALIFIED PERSONNEL.**

### C. NHTC/NHPC

- (1) The self-diagnostic system built into the NHTC is continually checking the status of the electrical circuits to the fill valve, drain valve, primary voltage contactor, high water sensor and steam cylinder. The modulating signals from external humidistat and reduced manual capacity settings are taken into consideration. When problem symptoms are found, the NHTC/NHPC will take self-corrective actions, if applicable. It will, if necessary, respond by shutting itself down. Table 3 describes some of the conditions the NH unit can detect and warn or protect itself against. Table 4 contains a definition of the terms used in this section.

**Table 1. Troubleshooting Symptoms**

System	What to Check	Why
Nothing is happening when the on/off switch is turned on	Main power is on and matches the specified voltage on the specification label.	No, or improper voltage can cause the electronics or components not to respond.
	24 VAC output from the step-down transformer. Check high and low voltage.	24 VAC is required to power nearly all the components of the humidifier, including the electronics.
	Ensure that fuses in the humidifier and on the electronic boards are good. Ensure that 24 VAC is getting to the main board.	The fuses are in place to prevent damage to the electronics. If there was a surge the fuse may have blown to prevent damage to the unit.
	Door interlock open.	The door interlock has malfunctioned.
The unit will not fill or fills very slowly (less than 1" per minute)	Water supply is on and water pressure is between 30 to 80 psig	The proper water volume and pressure must be available as the valves in the NH unit rely on its pressure to control volume and operation. NORTEC recommends 55 to 60 PSIG.
	Unit is getting a demand signal or the unit is producing the required steam capacity. See ensuring demand Table 2.	The unit will not activate the fill valve without a demand for humidity. It will also only fill as necessary once there is a demand. Once it reaches the requested demand, it will stop filling.
	No leak at drain valve or around cylinder. Check for water coming out of the drain. Check the fill valve inlet. Check fill valve strainer. Check optional inline filter.	<p>The cylinder is held in by gravity and sealed by an O-ring. If not properly seated, it could leak and prevent the unit from filling.</p> <p>Drain stuck open</p> <p>Pressure in the steam line could also prevent filling causing the water in the fill cup to overflow to drain.</p> <p>Strainer is clogged.</p> <p>Fill valve may also be restricted after capturing debris in its filter.</p>
Unit will not humidify or is not reaching requested capacity.	Unit is getting a demand signal. Refer to Table 2.	Unit will not send power to the cylinder without a demand and safeties met.
	Capacity is manually limited.	The unit will not surpass the capacity dictated by the user in the software.
	Cylinder is full.	The unit will not fill further than a full cylinder. Operation requires it to try to concentrate the conductivity, which may take several hours, before it reaches full capacity.
Unit has faulted or has a warning	Check Table 3, Faults and Warning Codes	Each code is identified and each has individual causes and solutions.



**Table 2. Ensuring A Demand Signal**

Check	Why and How
Safety Loop (terminal 1 and 2) is closed	<p>The safety loop is checked to ensure that it is safe to operate. Checking to see 24 VAC from terminal 1 to ground, and terminal 2 to ground should indicate whether is closed.</p> <p>If found to be open, isolate which component in the safety loop is open to solve the issue. If suspect, confirm that it is connected and operating properly.</p>
Channel 1 has a signal.	<p>Whether for on/off or modulating, a voltage potential signal must be present between terminal 3 and 4 for the humidifier temperature.</p> <p>If on/off there should be 5 VDC.</p> <p>If VDC modulating, at least 25% of total possible signal must be present.</p> <p>If mA controlled, at least 25% of total possible signal must be present.</p> <p>If Transducer signals, the unit setpoint must be higher then the sensed room RH signal.</p>
Channel 2 has a signal	<p>Only applicable if configured to accept dual channel input.</p> <p>If VDC modulating, at least 25% of total possible signal must be present.</p> <p>If mA controlled, at least 25% of total possible signal must be present.</p> <p>If Transducer signals, the high limit setpoint must be higher than the sensed RH signal.</p>

## 2. TROUBLESHOOTING DISTRIBUTORS

### CAUTION



**KEEP IN MIND WHEN TROUBLESHOOTING DISTRIBUTORS THAT THEY ARE BEING USED WITH STEAM AND THEREFORE, ARE AND CAN REMAIN VERY HOT DURING THE TROUBLESHOOTING PROCESS.**

#### A. TROUBLESHOOTING ATMOSPHERIC DISTRIBUTORS

- (1) If the distributor is spitting out water, ensure that the distributor is installed level and check the condensate return for proper slope, check head above the trap, and check the trap that it is clear of obstructions.
- (2) If the distributor is condensing inside the duct, make sure the installation clearances are as indicated in Chapter 10-10 Installation, and make sure that the design conditions have not changed. If over humidification of the duct results, check controls and safeties (ensure safeties are properly installed and functioning).

## 3. SAM-e TROUBLESHOOTING

#### A. PROCEDURE

- (1) If the SAM-e is spitting out water, ensure that the distributor is installed per instructions in Chapter 10-10 Installation and check the condensate return for proper slope and trap and that it is clear of obstructions. The condensate return must be the lowest point of the SAM-e header.

- (2) If the SAM-e is condensing inside the duct, make sure that the design conditions have not changed.
- (3) If grommets leak, make sure the tubes are firmly inserted, if cracks or damage are found, replace grommet.

#### **4. BLOWER PACKS TROUBLESHOOTING**

##### **A. PROCEDURE**

- (1) An optional blower pack (BP), ensure power supplied to blower pack either from humidifier or other source, if present, gets its primary voltage from inside the humidifier. This way, only one external power source has to be connected to the equipment. Confirm this power source before troubleshooting the blower pack.
- (2) Ensure blower pack is installed per Chapter 10-10 Installation.
- (3) If fans are not functioning, confirm safety is not open. Fans are only ON when steam is being discharged.

#### **5. DIGITAL ON/OFF HUMIDISTAT SENSOR CALIBRATION**

##### **A. PROCEDURE**

- (1) The humidity sensor is factory calibrated, however, it can be field recalibrated.
  - (a) The calibration routine can be accessed by pressing and holding down the option button for five seconds. A new screen will appear with the calibration adjustments.
  - (b) Press the up  $\Delta$  or down  $\nabla$  buttons until the text *calH* appears on the LCD screen.
  - (c) To adjust the calibration press the Option  $\triangleright$  button. The screen should load to display the current calibration trim. The calibration trim can be adjusted by pressing the up or down buttons to the desired level and then pressing the option button to confirm the settings.
  - (d) Press the Power  $\text{\textcircled{I}}$  button to return to the normal display.

##### **NOTE**

A properly calibrated hygrometer should be used in conjunction with any calibration procedure.

**Table 3. NH System Messages**

<b>NHTC Display Message</b>	<b>LED state</b>	<b>System Action</b>	<b>Symptom Diagnosed</b>
E5: Cylinder B Controller missing	RED	Humidifier is in standby until problem corrected.	On power up, the controller cannot detect the driver board for cylinder B.
E6: Extendet Missing	RED	Humidifier activates its fault relay and interrupts its operation until communication is fixed.	The slave unit is not in communication with the master unit. Master unit powered?
E7: CPU CRC fault	RED	Humidifier activates its fault relay and interrupts operation.	Problem with the processor hardware or software.
W11: Safety Loop Open	GRN	Humidifier goes on standby.	ON/OFF controls wired between terminal 1 and 2 are open.
W12: Cylinder Max Level	NONE	Fill valve interrupted.	Water at top of cylinder.
E12: Cylinder max Level no current	RED	Humidifier activates its fault relay and interrupts its operation.	The high water sensor is activated but no current is measured in cylinder.
W13: Fill Timeout	GRN blink	The humidifier will attempt to clear any debris by pulsing the drain valve.	The fill valve has been activated for an extended period of time but water has not reached the sensor.
E13: Fill: Timeout	RED	The fill valve has been activated for an extended period of time but has not reached the sensor.	Humidifier stops operation and the fault relay is activated.
W15: Over current	YEL	The drain is activated to decrease the water level in the cylinder.	Measured current in the cylinder has exceeded 115% of rated output.
E15: Over Current	RED	Humidifier interrupts operation and the fault relay is activated.	Measured current in the cylinder has exceeded 115% of rated output.
W16: Excess Current	YEL	Humidifier interrupts operation and the fault relay is activated.	Measured current in the cylinder has exceeded 115% of rated output.
E16: Excess Current	RED	Humidifier interrupts operation and the fault relay is activated.	Measured current in the cylinder has exceeded 130% of rated output.

Probable Cause	Corrective Action
1. The driver board is damaged. 2. Controller is not configured correctly.	1. Replace the driver board. 2. Verify that the humidifier is a double unit. 3. Check that the driver board ribbon cable is connected to the main board.
1. The master unit is not configured correctly. 2. Is the RJ12 cable damaged? 3. Is an incorrect RJ12 cable used? 4. J2 ports on driver boards are not connected.	1. Verify configuration settings for the units. 2. Replace the RJ12 cable. 3. Replace with correct cable. 4. Check all connections to the processor board.
The electronics of the main PCB have diagnosed the main PCB (itself) as defective.	Reset humidifier and monitor display. If Error reoccurs within one minute of resetting the unit, the problem is with the main PCB. If the Error is not repeated, the primary power to the unit is suspect.
1. Current measurement core loose on driver board? 2. Primary wire not looped through CT core? 3. High water sensor plug is on an electrode pin.	1. Connect CT core. 2. Interrupt main power and rewire CT core. 3. Install high water plug on shrouded pin.
1. Is the drain stuck open? 2. Check system backpressure. 3. Is the water supply closed? 4. Drain leaking?	1. Clean drain valve or replace. 2. Install fill cup extension kit if required. 3. Open water supply. 4. Clean drain valve.
1. Is the water supply closed? 2. Is the drain leaking? 3. Check the system backpressure.	1. Open water supply. 2. Clean drain valve. 3. Clean drain valve or replace. 4. Install fill cup extension kit if required.
1. Is the drain blocked? 2. Is the cylinder filling too fast? 3. Was the wrong fill valve supplied? 4. Is there scale in the cylinder? 5. Is the water too conductive? 6. Is the wrong cylinder supplied? 7. Is the cylinder spent?	1. Clean the drain line. 2. Replace the fill valve. 3. Replace the fill valve. 4. Rinse the cylinder. 5. Change water supply. 6. Install the correct type of cylinder. 7. Replace the cylinder.
1. Is the drain blocked? 2. Is the drain restricted? 3. Is the cylinder filling too fast? 4. Was the wrong fill valve supplied? 5. Is there scale in the cylinder? 6. Is the water too conductive? 7. Was the wrong cylinder supplied?	1. Clean the drain line. 2. Clean the drain line. 3. Replace the fill valve. 4. Replace the fill valve. 5. Rinse the cylinder. 6. Change the water supply. 7. Install correct cylinder type.
1. Is the drain blocked? 2. Is the drain restricted? 3. Is the cylinder filling too fast? 4. Was the wrong fill valve supplied? 5. Is there scale in the cylinder? 6. Is the water too conductive?	1. Clean the drain line. 2. Clean the drain line. 3. Replace the fill valve. 4. Replace the fill valve. 5. Rinse the cylinder. 6. Change the water supply.
1. Is the drain blocked? 2. Is the drain restricted? 3. Is the cylinder filling too fast? 4. Was the wrong fill valve supplied? 5. Is there scale in the cylinder? 6. Is the water too conductive?	1. Clean the drain line. 2. Clean the drain line. 3. Replace the fill valve. 4. Replace the fill valve. 5. Rinse the cylinder. 6. Change the water supply.

**Table 3. NH System Messages (cont)**

NHTC Display Message	LED state	System Action	Symptom Diagnosed
E17: Req off current	RED	Humidifier interrupts operation and the fault relay is activated.	With no system demand, current is detected in the cylinder.
W18: Foam	YEL	System will activate selected foam algorithm. (See Figure 7.)	System has detected foaming and will attempt to self correct if foam mode is active.
E18: Foam	RED	System will activate selected foam algorithm. (See Figure 7.)	System has detected foaming and will attempt to self correct if foam mode is active.
W19: Cylinder spent	YEL	The electronics allow the cylinder to be reset up to four times before locking out the humidifier.	Electronics have determined cylinder is spent. Within the next 72 hours the humidifier will stop.
E19: Cylinder spent	YEL, RED	Humidifier interrupts operation and the fault relay is activated.	Electronics have determined that the cylinder is spent.
W20: Conductivity too low	YEL	Humidifier will continue to operate on this water supply.	Water conductivity is determined to be less than optimum.
W23: Control sensor broken	YEL	Humidifier put on standby. After a timeout period, this warning becomes a fault.	Electronics cannot detect the control RH sensor connected to the humidifier.
E23: Control sensor broken	RED	Humidifier interrupts operation and the fault relay is activated.	Electronics cannot detect the control RH sensor connected to the humidifier.
W24: Limit sensor broken	YEL	Humidifier put on standby. After a timeout period, this warning becomes a fault.	Electronics cannot detect the limit RH sensor connected to the humidifier.
E24: Limit sensor broken	RED	Humidifier interrupts operation and the fault relay is activated.	Electronics cannot detect the limit RH sensor connected to the humidifier.
W25: 3-day idle drain activated	YEL	The humidifier drains the cylinder after three days of inactivity.	This safety feature drains standing water.
W26: 3-day forced drain activated	YEL	The humidifier drains the cylinder after three days of operation.	This customer selected feature drains the cylinder to remove minerals.

Probable Cause	Corrective Action
1. Is the contactor closed but not energized? 2. Does the processor board display capacity output but contactor is open?	1. Replace the contactor. 2. Replace the driver board.
1. Back pressure? 2. Organics present in water? 3. Insufficient drain or over concentration.	1. Verify drain is functioning and clean. 2. Verify steam line installation. 3. Check optional inline filter.
1. Back pressure? 2. Organics present in water? 3. Insufficient drain or over concentration.	1. Verify drain is functioning and clean. 2. Verify steam line installation. 3. Check optional inline filter.
The cylinder must be replaced with the same type and model.	When ordering a new cylinder, quote the model number of cylinder presently installed in the humidifier or serial number of humidifier.
The cylinder must be replaced with the same type and model.	When ordering a new cylinder, quote the model number presently installed in the humidifier.
1. Is the drain leaking? 2. Adjust drain factor. 3. Check the system backpressure. 4. Is salt required?	1. Clean the drain valve. 2. Set drain factor to 0.7. 3. Install a fill cup extension kit if required. 4. Add one teaspoon of table salt.
1. Is the sensor powered? 2. Is the sensor wiring correct? 3. Is the sensor defective? 4. Is the RH less than 5%?	1. Use a multimeter to check that the sensor is powered. 2. Verify wiring is correct as per wiring instructions. 3. Replace the sensor. 4. RH values under 5% are interpreted as a broken sensor.
1. Is the sensor powered? 2. Is the sensor wiring correct? 3. Is the sensor defective? 4. Is the RH less than 5%?	1. Use a multimeter to check that the sensor is powered. 2. Verify wiring is correct as per wiring instructions. 3. Replace the sensor. 4. RH values under 5% are interpreted as a broken sensor.
1. Is the sensor powered? 2. Is the sensor wiring correct? 3. Is the sensor defective? 4. Is the RH less than 5%?	1. Use a multimeter to check that the sensor is powered. 2. Verify wiring is correct as per wiring instructions. 3. Replace the sensor. 4. RH values under 5% are interpreted as a broken sensor.
1. Is the sensor powered? 2. Is the sensor wiring correct? 3. Is the sensor defective? 4. Is the RH is less than 5%?	1. Use a multimeter to check that the sensor is powered. 2. Verify wiring is correct as per wiring instructions. 3. Replace the sensor. 4. RH values under 5% are interpreted as a broken sensor.
---	To disable this feature, consult the programming manual shipped with the humidifier.
---	To disable this feature, consult the programming manual shipped with the humidifier.

**Table 3. NH System Messages (cont)**

<b>NHTC Display Message</b>	<b>LED state</b>	<b>System Action</b>	<b>Symptom Diagnosed</b>
W27: Safety loop instability	YEL	The safety loop is interrupting humidifier operation.	A security control is causing the safety loop to switch on and off too rapidly.
W28: demand signal instability	YEL	The demand signal is swinging from low demand to high demand too quickly.	The demand signal is unstable.
W29: limit signal instability	YEL	The limit signal is swinging from low demand to high demand too quickly and the humidifier cannot respond.	The limit signal is unstable.
W30: Modbus remote disable	YEL	The humidifier is being controlled via the network, not locally.	The humidifier has been disabled by a network message.
W43: Keep warm active	YEL	This is a customer selectable feature to keep the cylinder water warm.	The humidifier is in standby mode. The cylinder may energize at any time.
W44: Demand signal short cycling	YEL	The cylinder automatically reduces the humidifier output to stabilize operation.	The demand signal is cycling on and off too frequently.
W45: safety loop short cycling	YEL	The cylinder automatically reduces the humidifier output to stabilize operation.	The demand signal is cycling on and off too frequently.
W46: RH high warning	YEL	An alarm indication is generated.	RH levels higher than the limit set have been detected. The humidifier should not be operational with this warning activated.
W47: RH low warning	YEL	The humidifier is operating and an alarm indication is generated.	RH levels lower than the limit set have been detected. The humidifier should be operational with this warning activated.
W49: wrong cylinder installed	YEL	An alarm indication is generated.	The cylinder installed is not the recognized type for the humidifier.
E50: Modbus Timeout	RED	Systems shuts down.	Time window for Modbus has elapsed.

Probable Cause	Corrective Action
1. The high limit is too close to the distributor. 2. Is there loose wiring? 3. Are there defective controls? 4. Is the safety high limit set point is too low?	1. Relocate high limit 10 feet from the steam distributor. 2. Check all wires at the safety controls. 3. Replace any defective device. 4. Change high limit set point to 85% or more.
1. The high limit is too close to the distributor. 2. Is the controller defective? 3. Are the P and I settings incorrect?	1. Relocate high limit 10 feet from the steam distributor. 2. Replace the controller. 3. Adjust the P and I constants.
1. The high limit is located too close to the distributor. 2. Is the controller defective? 3. Are the P and I settings incorrect? 4. Safety high limit set point is set too low.	1. Relocate high limit 10 feet from the steam distributor. 2. Replace the controller. 3. Adjust the P and I constants. 4. Change high limit set point to 85% or more.
---	Contact the system administrator to override the remote command.
---	To disable this feature, consult the programming manual shipped with the humidifier.
1. Is the humidifier oversized? 2. Check the sensor location. 3. Are the P and I settings incorrect?	1. Reduce manual capacity setting by 50%. 2. The sensor should be located away from doors and drafts. 3. Adjust the P and I constants.
1. Is the humidifier oversized? 2. Is the high limit located too close to the distributor? 3. Are the safety controls damaged?	1. Reduce manual capacity setting by 50%. 2. Relocate the high limit to 10 feet from the steam distributor. 3. Replace any damaged controls.
1. Is the humidifier still operating? 2. Is the humidifier oversized?	1. Verify that the RH setpoint is less than the RH high limit setting. 2. Reduce the manual capacity setting by 50%.
1. Is the humidifier still operational? 2. Is the humidifier oversized?	1. Verify that the RH setpoint is greater than the RH low limit setting. 2. Set the manual capacity setting to 100%. 3. Add more humidifiers.
---	Verify that the replacement cylinder is the same as the old cylinder.
1. Loose wire. 2. Electronics damaged. 3. Electromagnetic Interference.	1. Verify cables. 2. Replace electronics or contact factory.



**Table 4. Term Definitions**

Term	Definition
RATED AMPS	Refers to amps listed on the humidifier specification label.
SHORT CYCLING	When the 'on time' of the humidifier is less than ten minutes upon a call for humidity. To correct short cycling, all humidifiers have a capacity adjustment which allows the output of the humidifier to be reduced as low as 20% of rated output, thus extending the 'on time' required to maintain output.
FOAMING	This phenomenon can occur in water when the impurities, already in the water, reach an excess concentration as result of boiling away pure water, and the continued boiling action agitating the contained water. The humidifier electronics are designed to prevent this occurrence, although in extreme cases water will foam with little concentration making it necessary to have the drain time of the water, contained in the cylinder, increased. Foaming is normally caused by short cycling, a restricted drain, or back pressure. The foam generated in these instances, is conductive and may lead to a false full cylinder indication if the level of the foam approaches the top of the cylinder.
BACK PRESSURE	This can be caused by restriction of steam flow caused by long steam runs; improperly sloped steam lines; elbows changing the direction of the steam flow from horizontal to vertical without a drain leg, any plumbing detail allowing the accumulation of condensate; undersized steam line; improper steam distributor; downward air flow onto the distributor creating excess static pressure at the steam outlets; or high static pressure ducts (not probable). To overcome excess static pressure in the duct, a fill cup extension kit should be used. In downflow applications, a downflow distributor should be used but in some cases the fill cup extension will also be required.
RESET UNIT (HUMIDIFIER)	To reset the humidifier, the ON/OFF switch at the front of the humidifier should be switched to the OFF position for a minimum of five seconds and then switched back to the ON position.
MONITORED LEG	Refers to the primary wire to the cylinder which loops through the current sensing device on the driver PCB. This wire is terminated at the red cylinder plug at the cylinder. Units with six primary wires to the cylinder will monitor only one of the two wires, terminating with red plugs.
CONDENSATE	Refers to steam that has condensed to a liquid.

## 6. 0-10V DIGITAL HUMIDISTAT SENSOR CALIBRATION

### A. PROCEDURE

- (1) The humidity sensor is factory calibrated, however, it can be field recalibrated. The calibration routine can be accessed by pressing and holding down the option button for five seconds. A new screen will appear with the calibration adjustments.
  - (a) Press the up  $\Delta$  or down  $\nabla$  buttons until *calH* appears on the LCD screen.
  - (b) To adjust the calibration press the Option  $\triangleright$  button. The screen should load to display the current calibration trim.
  - (c) The calibration trim can be adjusted by pressing the up or down buttons to the desired level and then pressing the option button to confirm the settings.
  - (d) Press the Power  $\text{\textcircled{1}}$  button to return to the normal display.

# 10-50

# TECHNICAL

## 1. WIRING AND TERMINALS

### A. HUMIDIFIER CONTROL INFORMATION

- (1) See Figure 7 and Figure 9 in Chapter 10-10 for Controller and Transducer terminal definitions. See Figure 6 in Chapter 10-10 for low voltage terminal strip terminal definitions.

**Table 1. Controller and Sensor Specifications**

Power Supply	Operating Voltage	24 VAC $\pm$ 10% 50/60 Hz
	Power Consumption	Max. 3 VA
	Internal Rectification	Half-wave rectified
Signal Inputs	Analog Input Input Signal Resolution Accuracy	A11 2-10 VDC 39 mV, 0.078 mA $\pm$ 2%
	Temperature Input Range	External Thermistor -40° to 140°C (-40° to 284°F)
	Humidity Input: Range Accuracy Repeatability	0 to 100 %RH $\pm$ 3.0% at 25°C (77°F) $\pm$ 0.5%
Signal Outputs	Digital Outputs Maximum Load	DO1 24 VAC 2A max.
Environment	Operation Temperature Humidity	0° to 50°C(32° to 122°F) <95%RH
Housing Materials	Cover, back Mounting Plate	Fire proof ABS plastic Galvanized Steel

**B. NH WIRING**

(1) See Figure 1 and 2 for the NHTC/NHPC Single and Double Unit Wiring diagrams.

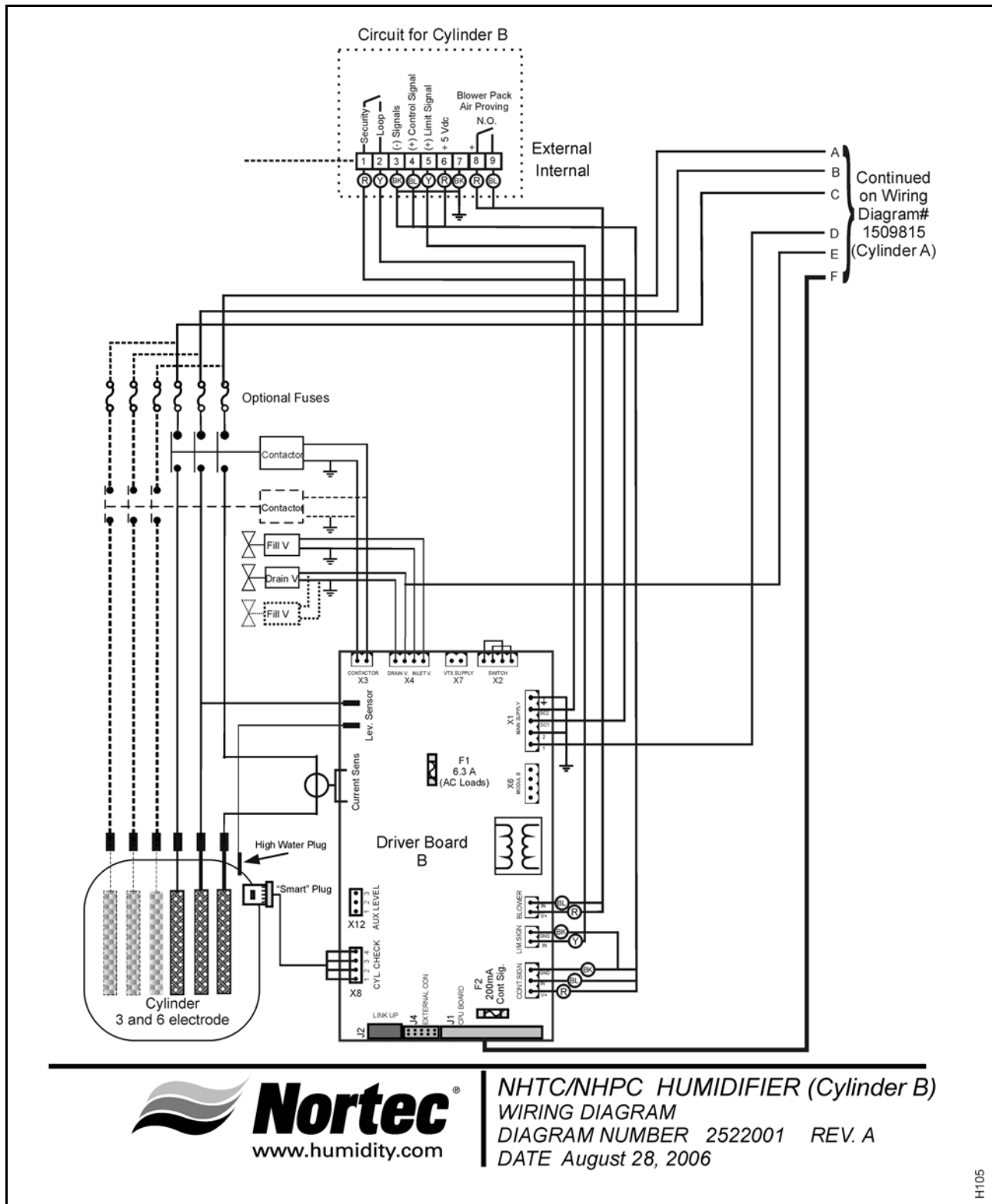

Figure 1. NHTC/NHPC Double Unit Wiring Diagram

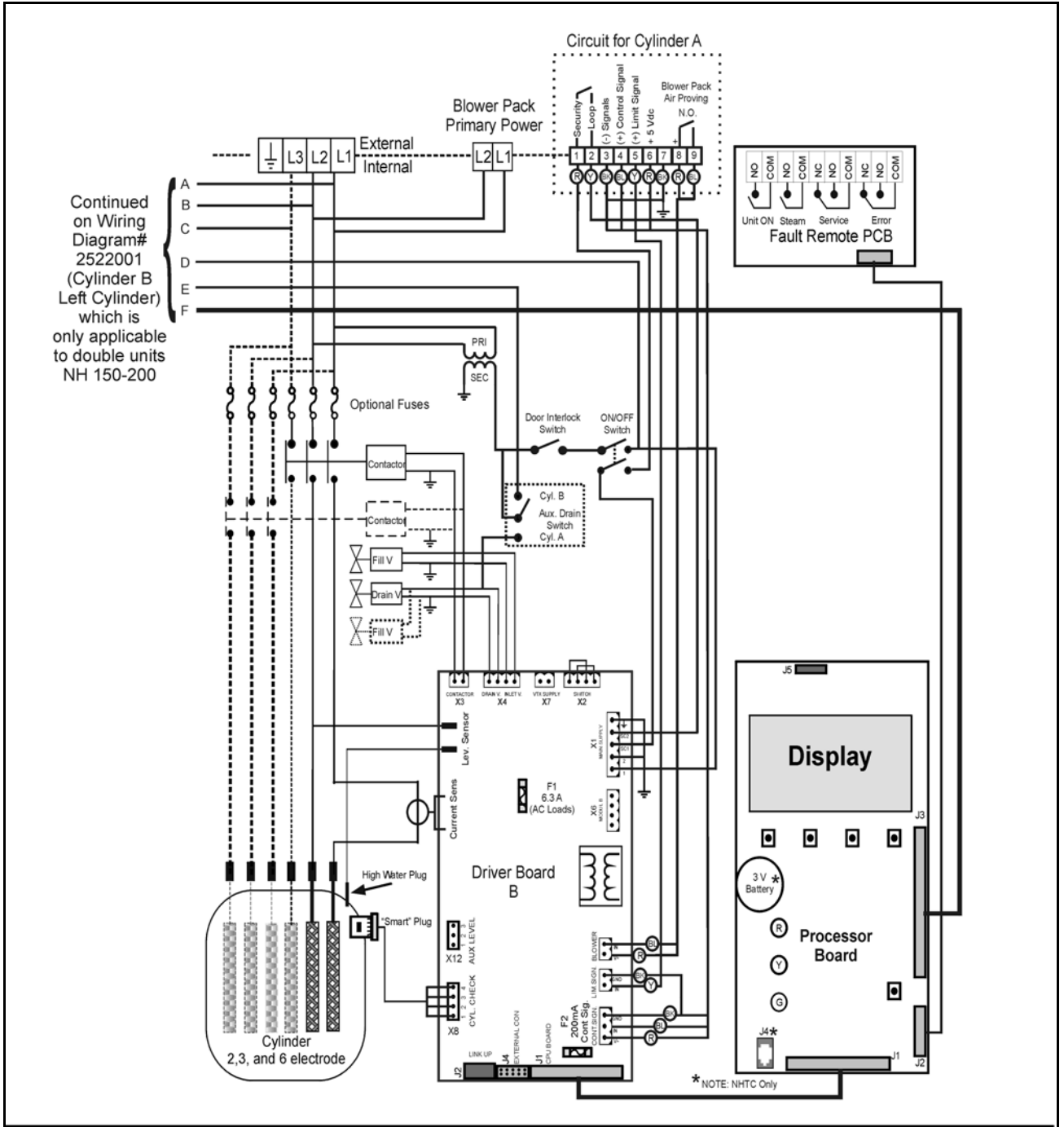

Figure 2. NHTC/NHPC Wiring Diagram

## 2. CHECK LISTS

### A. PRE-NORTEC ONLINE START UP CHECKLIST WIRING

**(1) Humidifier-to-Humidifier Connection:**

Each individual Humidifier linked to lead Unit.

Connection can be direct or daisy-chained to other units.

**(2) Network Connection:**

Lead Unit wired to Local Network (Ethernet, GPRS, Dial-up).

Network activity verified.

**(3) Controls Wired:**

Directly to humidifiers.

**(4) Start-Up Procedure:**

Ensure power is being supplied to the humidifier and Nortec Online Module.

Verify power to NetBiter (Power LED should be lit).

After power-up, verify network communication.

Verify variable operation after mapping is complete.

Perform regular humidifier start-up check.

### B. PRE-NORTEC LINKS START-UP CHECKLIST

**(1) Humidifier-to-Humidifier Connection:**

Each individual Humidifier linked to lead Unit.

Connection can be direct or daisy-chained to other units.

**(2) Network Connection:**

Lead Unit wired to Local BMS.

Network activity verified.

**(3) Controls Wired:**

Directly to humidifiers.

**(4) Start-Up Procedure:**

Verify power to NORTEC Links module.

Verify power to I/O-Controller.

Adjust Network address dials to desired address (BACnet/IP address is preset at factory).

After power-up, verify network communication.

Map desired network variables to BMS.

Verify variable operation after mapping is complete.

Perform regular humidifier start-up check.

**C. HUMIDIFIER MANDATORY PRE-START UP CHECKLIST**

Unit Serial #: \_\_\_\_\_ No. of humidifiers: \_\_\_\_\_ Tag: \_\_\_\_\_  
 Unit type: \_\_\_\_\_ Voltage: \_\_\_\_\_V/\_\_\_\_ph Steam output: \_\_\_\_\_lbs/hr  
 Customer/Job: \_\_\_\_\_ Address: \_\_\_\_\_  
 Inspected by: \_\_\_\_\_ Date of inspection: \_\_\_\_/\_\_\_\_/\_\_\_\_

**WATER QUALITY:**

Well water \_\_\_\_ City water \_\_\_\_ Softened water \_\_\_\_ RO / DI water \_\_\_\_  
 Conductivity: \_\_\_\_\_ mhmos Hardness: \_\_\_\_\_ gr.

**HUMIDIFIER MOUNTING:**

Clearances around the unit	Acceptable	Obstruction
- Front (door opens freely?)	3 ft min. _____	
- Top (steam lines)	2 ft min. _____	
- Bottom (fill, drain, controls)	2 ft min. _____	
- Right (main pwr)	2 ft min. _____	

**STEAM LINES:**

- Slope up 2 in. per 12 in. \_\_\_\_  
 - Slope down 0.500 in. per 12 in. \_\_\_\_  
 - Traps \_\_\_\_  
 - Insulated \_\_\_\_  
 - Length/Size \_\_\_\_/\_\_\_\_\_  
 - 90 degree elbows \_\_\_\_ qty: \_\_\_\_ - 45 degree Elbows \_\_\_\_ qty: \_\_\_\_  
 - Can condensate be trapped anywhere in the steam line? yes \_\_\_\_ no \_\_\_\_

**CONDENSATE LINES:**

- Sloped back to drain \_\_\_\_  
 - Trapped 2 in. more than static duct pressure \_\_\_\_  
 - Size \_\_\_\_  
 - Stainless steel \_\_\_\_ or plastic \_\_\_\_  
 - \_\_\_\_% Vertical \_\_\_\_% Horizontal

**WATER LINES:**

- 0.050 in. at max 4ft from the unit \_\_\_\_ - 3/8 in. connection at fill G  
 - Water pressure: 30-80 psig \_\_\_\_ - PVC \_\_\_\_ - Stainless steel \_\_\_\_

**DRAIN LINES:**

- Air gap located within 3 ft of the unit \_\_\_\_ - Sloped to drain \_\_\_\_ - Size: \_\_\_\_\_

**CYLINDER:**

- Cylinder properly installed and sitting upright

**WIRING:**

- No loose wires around the unit or on the PC board? yes \_\_\_\_ no \_\_\_\_

**CONTROLS:**

Installed Location / Wiring /Setting	Installed Location / Wiring /Setting
- High limit: ____	- Air proving: ____
- Mod controller: ____	- Other: ____

**POWER:**

- Voltage, amperage rating and fuse correspond to Spec Label: \_\_\_\_  
 - Disconnect switch located close to humidifier: \_\_\_\_

**D. HUMIDIFIER MANDATORY START-UP CHECKLIST AND QUICK REFERENCE**

Unit Serial #: \_\_\_\_\_ No. of humidifiers: \_\_\_\_\_ Tag: \_\_\_\_\_  
 Unit type: \_\_\_\_\_ Voltage: \_\_\_\_\_V/\_\_\_\_\_ph Steam output: \_\_\_\_\_lbs/hr  
 Customer/Job: \_\_\_\_\_ Address: \_\_\_\_\_  
 Inspected by: \_\_\_\_\_ Date of inspection: \_\_\_\_/\_\_\_\_/\_\_\_\_

---

**1. PRELIMINARY:**

- Pre-start-up checklist completed? yes \_\_\_ no \_\_\_  
 If no, return to Pre-Start-up Checklist before going on with start-up procedure.

**2. START-UP PROCEDURE:**

The prerequisites for getting power and water into the steam cylinder are as follows:

- check that main breaker is on and power is at the unit.
- check that main water shut-off valve is open.
- on/off/drain switch must be switched on.
- control circuit 1-2 must be made.
- modulation humidistat, if present, must be calling.
- door interlock switch must be made (interlock switch can be pulled out to operate unit).

The unit will undergo a self-test to ensure integrity of all the components:

- NHTC Start-Up Unit Cylinder
- Reading Cylinder Data
- Inlet Valve
- Drain Valve
- Heat Controller
- Pump
- Bleed Valve
- Steam Relay
- Service Relay
- Error Relay
- Operation Relay

It will then start filling the cylinder and begins normal operation. Most water does not contain enough conductivity for full boil on initial start-up. Units will need to concentrate the water over a time period (hours to days).

**Remarks:**

---



---



---



---



## E. PERIODIC MAINTENANCE CHECKLIST AND QUICK REFERENCE (PAGE 1 OF 2)

Unit Serial #: \_\_\_\_\_ No. of humidifiers: \_\_\_\_\_ Tag: \_\_\_\_\_  
Unit type: \_\_\_\_\_ Voltage: \_\_\_\_\_V/\_\_\_\_ph Steam output: \_\_\_\_\_lbs/hr  
Customer/Job: \_\_\_\_\_ Address: \_\_\_\_\_  
Inspected by: \_\_\_\_\_ Date of inspection: \_\_\_\_/\_\_\_\_/\_\_\_\_

---

### WHEN TO REPLACE THE CYLINDER:

NHTC/NHPC light indication and LCD display:

1. Yellow and Green light with W19: Cylinder Spent indicates the cylinder must be replaced in the next 72 hours.
2. Red and Yellow light with E19: Cylinder Spent indicates the cylinder is at the end of its life and must be replaced.

### CYLINDER REPLACEMENT PROCEDURE:

1. Turn off water supply to unit.
2. Activate drain to completely empty water content (less than 10 minutes)
3. When drained, stop drain and turn off unit.
4. Also open the main electrical disconnect switch and open plumbing.
5. Remove the cylinder plugs by pulling vertically. The plugs are press-fitted over the electrode pins protruding from the top of the cylinder.
6. Using a slotted screwdriver, loosen the steam line clamp(s) and pull steam line off the cylinder vertically.
7. Using a small slotted screwdriver, depress tab on the re-usable cable tie, if present, around the middle of the cylinder. This will loosen the cable tie to come apart for re-use later on.
8. The cylinder is now ready to be removed from the unit.

**CAUTION:** Cylinder and any remaining water might still be HOT.

9. Always clean the drain valve before installing a new cylinder. (see further below)
10. Remove the used cylinder and replace by a new one. Do not re-use cylinder.

### MANDATORY CLEANING OF THE DRAIN VALVE

1. Note that ring terminal for drain valve green ground wire is sandwiched between drain valve body and drain pan.
2. Remove two screws securing drain valve body to drain pan. Disconnect the two slip-on terminals from the two tabs on the (24 VAC) drain valve coil.
3. Remove hose clip and hose connection from drain valve body.
4. Drain valve assembly is now free to be taken to a sink for disassembly and cleaning.

**Important:** Tapered end of spring must be installed toward the solenoid.

5. Clean out the end of the hose, and then reconnect it to the drain valve body with the clamp.
6. Fit mounting screws through drain valve body, one through ring terminal on green ground wire.

**WARNING:** To prevent the possibility of electrical shock the green ground wire must be reinstalled before power is restored. Push the two slip-on terminals back onto the two tabs on the coil. The terminals, although not identical, are reversible.

**E. PERIODIC MAINTENANCE CHECKLIST AND QUICK REFERENCE (PAGE 2 OF 2)**

Unit Serial #: \_\_\_\_\_ No. of humidifiers: \_\_\_\_\_ Tag: \_\_\_\_\_  
Unit type: \_\_\_\_\_ Voltage: \_\_\_\_\_V/\_\_\_\_ph Steam output: \_\_\_\_\_lbs/hr  
Customer/Job: \_\_\_\_\_ Address: \_\_\_\_\_  
Inspected by: \_\_\_\_\_ Date of inspection: \_\_\_\_/\_\_\_\_/\_\_\_\_

---

**HOW TO INSTALL THE REPLACEMENT CYLINDER**

1. Reverse procedure should be followed to install new cylinder. Main disconnect is to be left open until cylinder is completely installed and reconnected.
2. Ensure that the re-usable cable tie and mounting brackets, within the unit, secure the cylinder properly.
3. The cylinder plug wires are colour-coded in accordance with coloured dots beside the electrode pins on top of the cylinder.
4. This colour coding must be adhered to when replacing cylinder plugs on pins.
5. With cylinders having six primary voltage cylinder plugs, it should be noted that there are two of each colour.
6. Care must be taken so that cylinder leads of the same color are always directly opposite each other as indicated by the dot formation on the top of the cylinder.
7. The white cylinder plug on all units is for the high water sensor electrode, which always goes on the single pin surrounded by a plastic shoulder.
8. Ensure that cylinder plugs fit snugly on the pins.
9. If cylinder plugs become loose, it is best to obtain a new replacement plug. Consult factory.

**EXTENDED SHUTDOWN:**

1. Before disconnecting power to the humidifier for a period of extended shutdown, ALWAYS DRAIN the cylinder first.
2. 'Open' the main external fused disconnect to stop power to the humidifier.
3. Close the shut-off valve in the water supply line feeding the humidifier.

**ACCESS SHOULD BE LIMITED TO AUTHORIZED PERSONNEL ONLY.**

4. NHTC 3 day drain: As long as the NHTC is powered, it will automatically drain the cylinder when there has not been a call for humidity for an extended period of time.
5. The cylinder will remain empty until there is a call for humidity at which time the fill valve will open and refill the cylinder.

This feature will reduce the possibility of corrosion of the electrodes and the possible accumulation of algae and bacteria growing in the cylinder.

**Remarks:**

---

---

---

---

### 3. SPARE PARTS AND EXPLODED VIEWS

#### A. ASD, BSD, CSD DISTRIBUTOR

(1) See Figure 3 for the ASD, BSD, CSD Distributor exploded view and spare parts.

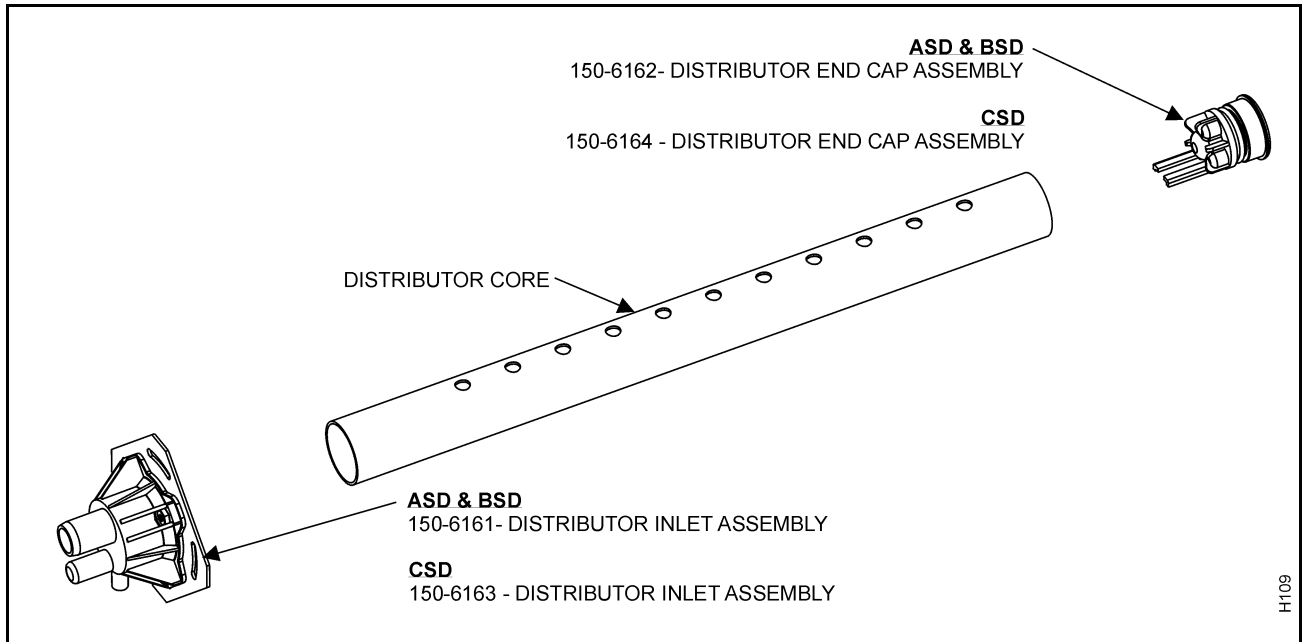

Figure 3. Distributor Exploded View and Spare Parts

#### B. SAM-e SPARE PARTS

(1) See Figure 4 for the SAM-e exploded view and spare parts.

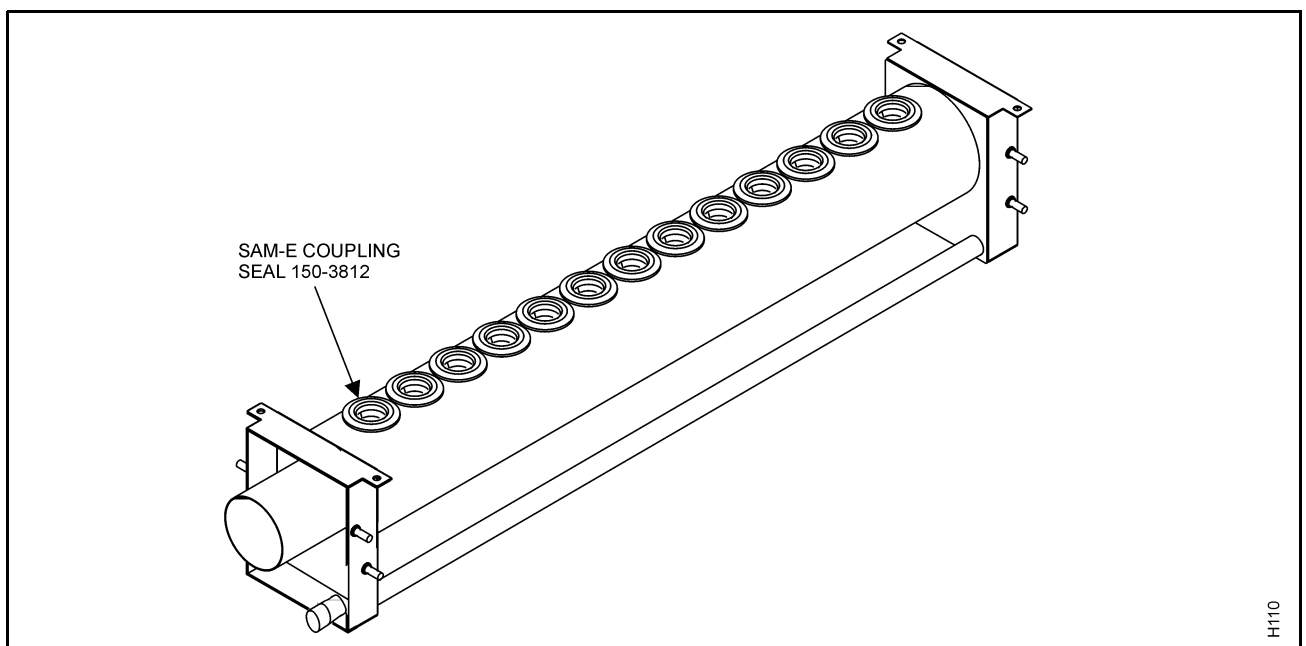

Figure 4. SAM-e Exploded View and Spare Parts

### C. NH SERIES HUMIDIFIER SPARE PARTS

- (1) See Figure 5 for the NHTC/NHPC plumbing compartment exploded view and spare parts and Table 2 for the parts list. See Figure 6 for the NHTC/NHPC electrical compartment exploded view and spare parts and Table 3 for the parts list.

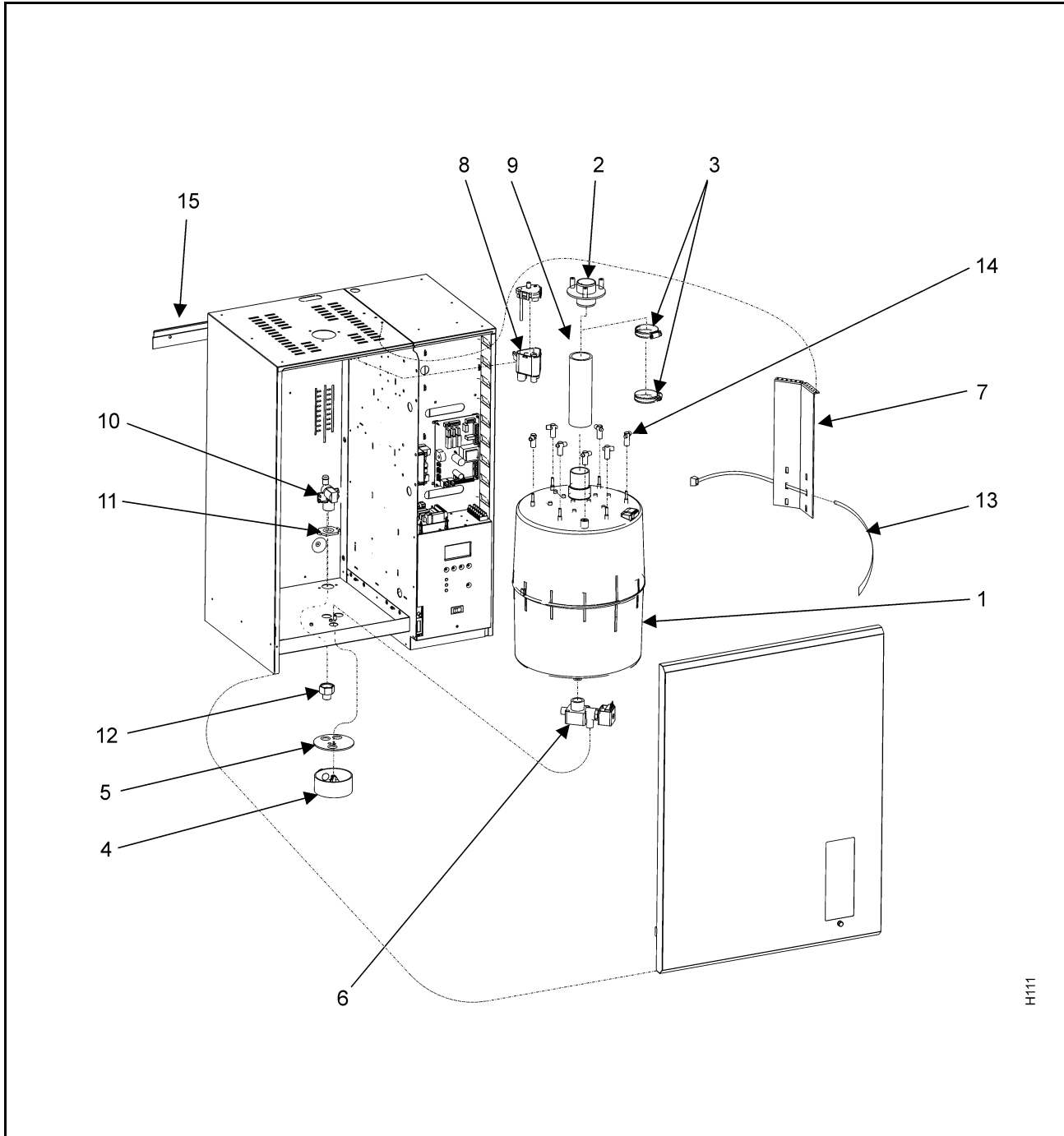
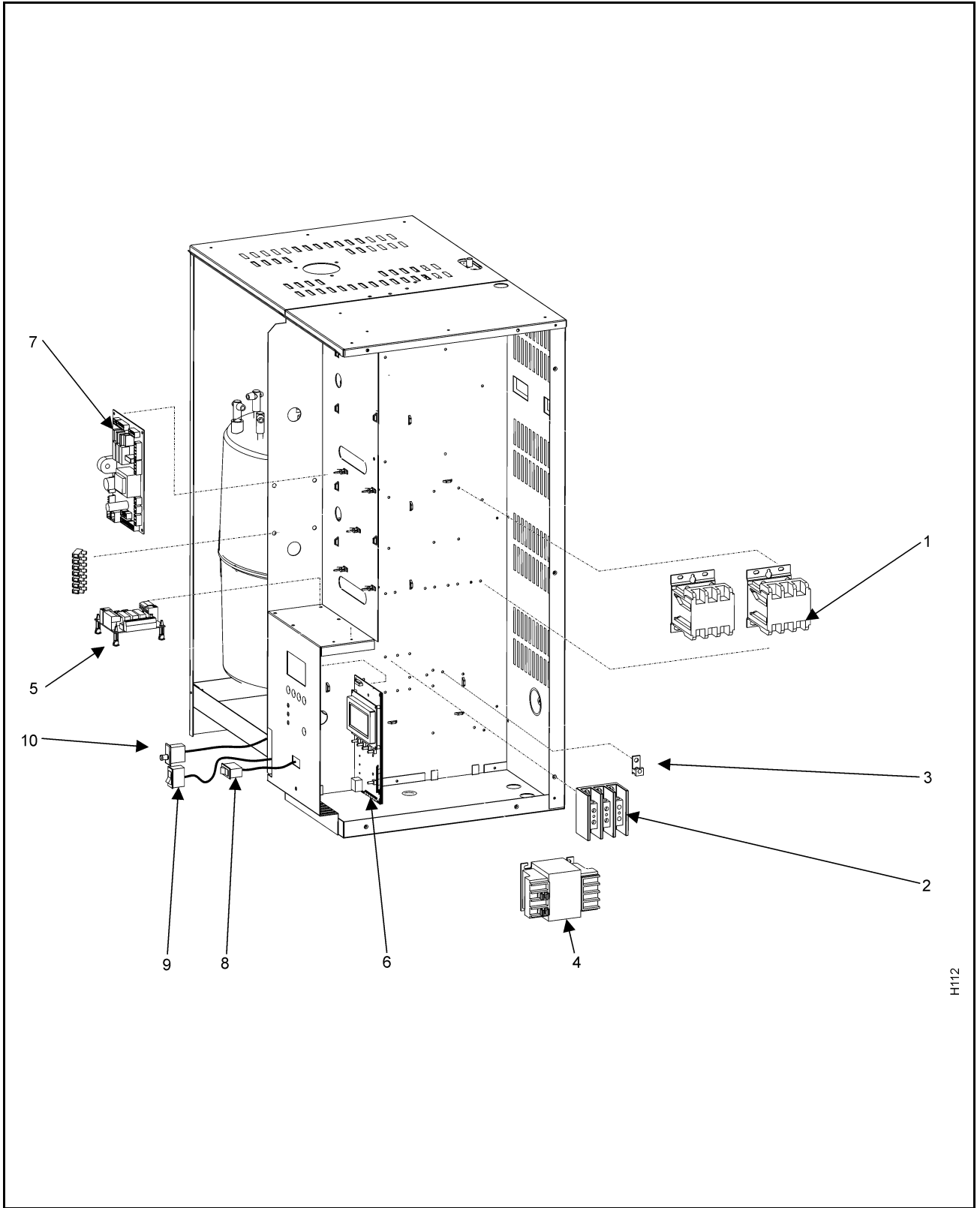

Figure 5. NHTC/NHPC Plumbing Compartment Exploded View and Spare Parts



**Table 2. NHTC/NHPC Plumbing Part List (cont)**

ITEM NO.	DESCRIPTION	NORTEC PART NO.	SINGLE PHASE										THREE PHASE															
			005	010	020	020	030	050	075	100	150	200	005	010	020	030	050	075	100	150	200							
		MODEL	110-120	220-240/1	220-240/1	220-240/1	220-240/1	220-240/1	220-240/3	380/1	440-480/1	550-600/1	208/1	220-240/3	380/3	440-480/3	550-600/3	208/3	220-240/3	380/3	440-480/3	550-600/3	208/3	220-240/3	380/3	440-480/3	550-600/3	
		VOLTS/PH	1	1	1	1	1	1	1	1	1	1	1	1	1	1	1	1	1	1	1	1	1	1	1	1	1	
10	VALVE, SINGLE FILL, 0.5 L/min	131-3244	1	1	1	1	1	1	1	1	1	1	1	1	1	1	1	1	1	1	1	1	1	1	1	1	1	
	VALVE, SINGLE FILL, 1.2 L/min	135-3017																										
	VALVE, SINGLE FILL, 2.0 L/min	135-3032																										
	VALVE, SINGLE FILL, 3.3L/min	135-3037																										
11	GASKET FOR FILL THRU CAB	145-5000	1	1	1	1	1	1	1	1	1	1	1	1	1	1	1	1	1	1	1	1	1	1	1	1	1	
12	FITTING BRASS 3/4 BSP / WASHER -1/2"NPT	150-6288	1	1	1	1	1	1	1	1	1	1	1	1	1	1	1	1	1	1	1	1	1	1	1	1	1	
13	CABLE TIE REUSABLE 1-400 CYL SZ	151-3003	1	1	1	1	1	1	1	1	1	1	1	1	1	1	1	1	1	1	1	1	1	1	1	1	1	
	CABLE TIE REUSABLE 5-600 CYL SZ	151-3005																										
	CYL PLUG WITH BLACK MARKER	151-0046	1	1	1	1	1	1	1	1	1	1	1	1	1	1	1	1	1	1	1	1	1	1	1	1	1	
	CYL PLUG WITH YELLOW MARKER	151-0049																										
	CYL PLUG WITH RED MARKER	151-0047	1	1	1	1	1	1	1	1	1	1	1	1	1	1	1	1	1	1	1	1	1	1	1	1	1	
14	CYLINDER PLUG 5MM 15A (HWS) MODIFIED	150-4150	1	1	1	1	1	1	1	1	1	1	1	1	1	1	1	1	1	1	1	1	1	1	1	1	1	
	SUPER PLUG W/ WIRE WITH BLACK MARKER	132-4264																										
	SUPER PLUG W/ WIRE WITH YELLOW MARKER	132-4265																										
	SUPER PLUG W/ WIRE WITH RED MARKER	132-4266																										
15	WALL BRACKET 5-30 LBS	145-7020	1	1	1	1	1	1	1	1	1	1	1	1	1	1	1	1	1	1	1	1	1	1	1	1	1	
	WALL BRACKET 50-100 LBS	145-7022																										
	WALL BRACKET 150-200 LBS	145-7023																										
	<b>OPTIONAL COMPONENTS</b>																											
	FOAM DETECTION OPTION																											
	FLOAT ASSEMBLY, FOAM DETECTION	252-3334	1	1	1	1	1	1	1	1	1	1	1	1	1	1	1	1	1	1	1	1	1	1	1	1	1	
	FILL CUP EXTENSION KIT																											
	FILLCUP EXTENSION KIT NHTC/NHPC	252-2160	1	1	1	1	1	1	1	1	1	1	1	1	1	1	1	1	1	1	1	1	1	1	1	1	1	
	DRAIN WATER COOLING																											
	VALVE, DUAL FILL, 3.3 L/min, 0.5 L/min	150-9688	1	1	1	1	1	1	1	1	1	1	1	1	1	1	1	1	1	1	1	1	1	1	1	1	1	
10	VALVE, DUAL FILL, 3.3 L/min, 1.2 L/min																											
	VALVE, DUAL FILL, 3.3 L/min, 2.0 L/min																											
	VALVE, DUAL FILL, 3.3 L/min, 3.3L/min																											



H112

**Figure 6. NHTC/NHPC Electrical Compartment Exploded View and Spare Parts**







THIS PAGE INTENTIONALLY LEFT BLANK

## WARRANTY

- (1) Walter Meier Inc. and/or Walter Meier Ltd. (hereinafter collectively referred to as THE COMPANY), warrant for a period of two years after installation or 30 months from manufacturer's ship date, whichever date is earlier, that THE COMPANY's manufactured and assembled products, not otherwise expressly warranted (with the exception of the cylinder), are free from defects in material and workmanship. No warranty is made against corrosion, deterioration, or suitability of substituted materials used as a result of compliance with government regulations.
- (2) THE COMPANY's obligations and liabilities under this warranty are limited to furnishing replacement parts to the customer, F.O.B. THE COMPANY's factory, providing the defective part(s) is returned freight prepaid by the customer. Parts used for repairs are warranted for the balance of the term of the warranty on the original humidifier or 90 days, whichever is longer.
- (3) The warranties set forth herein are in lieu of all other warranties expressed or implied by law. No liability whatsoever shall be attached to THE COMPANY until said products have been paid for in full and then said liability shall be limited to the original purchase price for the product. Any further warranty must be in writing, signed by an officer of THE COMPANY.
- (4) THE COMPANY's limited warranty on accessories, not of the companies manufacture, such as controls, humidistats, pumps, etc. is limited to the warranty of the original equipment manufacturer from date of original shipment of humidifier.
- (5) THE COMPANY makes no warranty and assumes no liability unless the equipment is installed in strict accordance with a copy of the catalog and installation manual in effect at the date of purchase and by a contractor approved by THE COMPANY to install such equipment.
- (6) THE COMPANY makes no warranty and assumes no liability whatsoever for consequential damage or damage resulting directly from misapplication, incorrect sizing or lack of proper maintenance of the equipment.
- (7) THE COMPANY makes no warranty and assumes no liability whatsoever for damage resulting from freezing of the humidifier, supply lines, drain lines, or steam distribution systems.
- (8) THE COMPANY makes no warranty and assumes no liability whatsoever for equipment that has failed due to ambient conditions when installed in locations having climates below 14°F (-10°C) during January or above 104°F (40°C) during July. (See Table 1: Weather Design Data above).
- (9) THE COMPANY retains the right to change the design, specification and performance criteria of its products without notice or obligation.

INSTALLATION DATE (MM/DD/YYYY)
--------------------------------

MODEL #
SERIAL #
CYLINDER #



Cylinder Replacement Date (MM/DD/YYYY)



Authorized Agent:

**U.S.A.**  
**Walter Meier (Climate USA) Inc.**  
 826 Proctor Avenue  
 Ogdensburg, NY 13669  
 TEL: 1-866-NORTEC-1  
 EMAIL: northamerica.climate@waltermeier.com  
 WEBSITE: www.humidity.com

**CANADA**  
**Walter Meier (Climate Canada) Ltd.**  
 2740 Fenton Road  
 Ottawa, ON K1T 3T7  
 TEL: 1-866-NORTEC-1  
 FAX: (613) 822-7964

## Free Manuals Download Website

<http://myh66.com>

<http://usermanuals.us>

<http://www.somanuals.com>

<http://www.4manuals.cc>

<http://www.manual-lib.com>

<http://www.404manual.com>

<http://www.luxmanual.com>

<http://aubethermostatmanual.com>

Golf course search by state

<http://golfingnear.com>

Email search by domain

<http://emailbydomain.com>

Auto manuals search

<http://auto.somanuals.com>

TV manuals search

<http://tv.somanuals.com>