



296-1011-202

Document Revision 02.01

CVX Multi-Service Access Switch
Release 5.0
August 2001

CVX 600 Multi-Service Access Switch

Hardware Installation Guide

NORTEL
NETWORKS™

*Nortel, Nortel Networks, the Nortel Networks corporate logo, the Globemark design, and CVX are trademarks of Nortel Networks. All other trademarks are the property of their owners.

© 2001 Nortel Networks. All rights reserved. Information in this document is subject to change without notice. Nortel Networks assumes no responsibility for any errors that may appear in this document.

Printed in the USA

Regulatory and Safety

Regulatory Information

U.S.A. Requirements

FCC Radio Frequency Notice for the CVX 600 Access Switch

This device complies with Part 15 of the FCC Rules. Operation is subject to the following two conditions:

- This device may not cause harmful interference.
- This device must accept any interference received, including interference that may cause undesired operation.

Note: This equipment has been tested and found to comply with the limits for a Class A digital device, pursuant to Part 15 of the FCC Rules. These limits are designed to provide reasonable protection against harmful interference in a residential installation. This equipment generates, uses and can radiate radio frequency energy and, if not installed and used in accordance with the instructions, may cause harmful interference to radio communications. However, there is no guarantee that interference will not occur in a particular installation. If this equipment does cause harmful interference to radio or television reception, which can be determined by turning the equipment off and on, the user is encouraged to try to correct the interference by one or more of the following measures:

- Reorient or relocate the receiving antenna.
- Increase the separation between the equipment and receiver.
- Connect the equipment into an outlet on a circuit different from that to which the receiver is connected.
- Consult the dealer or an experienced radio/TV technician for help.

FCC Part 68 General Information

This equipment complies with Part 68 of the FCC rules. This equipment uses the following USOC RJ-48 jacks:

Interface	Service Code	Facility Code
1.544 Mb/s superframe format (SF) without line power	6.0N	04DU9-BN
1.544 Mb/s superframe format (SF) and B8ZS without line power	6.0N	04DU9-DN
1.544 Mb/s ANSI extended superframe format (ESF) without line power	6.0N	04DU9-1KN
1.544 Mb/s ANSI extended superframe format (ESF) and B8ZS without line power	6.0N	04DU9-1SN

Regulatory Information

If you experience trouble with this equipment, please contact Nortel Networks for repair and warranty information. If there is a problem with the network, the telephone company may request that you remove the equipment from the network until the problem is resolved.

Nortel Networks recommends that you install an AC surge protector in the AC outlet to which the equipment is connected. This helps to prevent damage to the equipment caused by local lightning strikes or other electrical surges.

FCC and Telephone Company Procedures and Requirements

In order to connect this equipment to the network, you must provide the local telephone company with the registration number of this equipment, and you must order the proper connections.

To order the proper service, provide the telephone company with the following information:

- Number of required jacks and their USOC numbers
- Sequence in which the trunks are to be connected
- Facility interface codes, by position

UL Listing and CSA Certification - U.S. and Canada

This equipment has been Listed by Underwriter Laboratories, Inc. and certified by CSA for use in the U.S. and Canada to the requirements of UL 1950. Third Edition - Safety of Information Technology Equipment. Including Electrical Business equipment and Canadian Standards Association CAN/CSA C22.2 No. 950-95 Third Edition.

Australian Requirements



N441

The regulator for telecommunications and radio communications in Australia is the ACA (Australian Communications Authority). This equipment is labeled with the A-Tick mark, which indicates that the product complies with both EMC and Telecommunications requirements and establishes a traceable link between the equipment and the manufacturer. It is also an indication to the user that the product can be connected to a telecommunications network.

Canadian Requirements

Canadian Department of Communications Radio Interference Regulations

This digital apparatus (CVX 600) does not exceed the Class A limits for radio-noise emissions from digital apparatus, as documented in the Radio Interference Regulations of the Canadian Department of Communications.

Règlement sur le brouillage radioélectrique du ministère des Communications

Cet appareil numérique (CVX 600) respecte les limites de bruits radioélectriques visant les appareils numériques de classe A prescrites dans le Règlement sur le brouillage radioélectrique du ministère des Communications du Canada.

Canada CS-03 Rules and Regulations

Note: The Canadian Department of Communications label identifies certified equipment. The certification means that the equipment meets certain telecommunications network protective, operational, and safety requirements. The Department does not guarantee the equipment will operate to the user's satisfaction.

Before installing this equipment, ensure that it is permissible to connect to the facilities of the local telecommunications company. You must install this equipment using an acceptable connection method.

Repairs to certified equipment should be made by a supplier-designated representative. If you make repairs or alterations to this equipment, or if the equipment malfunctions, the telecommunications company may request that you disconnect the equipment.

You should ensure, for your own protection, that the electrical ground connections for the power utility, telephone lines, and internal water-pipe system, if present, are connected. This precaution may be particularly important in rural areas.

Caution: You should not attempt to make such connections. You should contact the appropriate inspection authority or electrician.

Canada CS-03 Règles et règlements

Note: L'étiquette du ministère des Communications du Canada indique que l'appareillage est certifié, c'est-à-dire qu'il respecte certaines exigences de sécurité et de fonctionnement visant les réseaux de télécommunications. Le ministère ne garantit pas que l'appareillage fonctionnera à la satisfaction de l'utilisateur.

Avant d'installer l'appareillage, s'assurer qu'il peut être branché aux installations du service de télécommunications local. L'appareillage doit aussi être raccordé selon des méthodes acceptées.

Les réparations de l'appareillage certifié devraient être confiées à un service désigné par le fournisseur. En cas de réparation ou de modification effectuées par l'utilisateur ou de mauvais fonctionnement de l'appareillage, le service de télécommunications peut demander le débranchement de l'appareillage.

Pour leur propre sécurité, les utilisateurs devraient s'assurer que les mises à la terre des lignes de distribution d'électricité, des lignes téléphoniques et de la tuyauterie métallique interne sont raccordées ensemble. Cette mesure de sécurité est particulièrement importante en milieu rural.

Attention: Les utilisateurs ne doivent pas procéder à ces raccordements, mais doivent plutôt faire appel aux pouvoirs de réglementation en cause ou à un électricien, selon le cas.

European Requirements



EMI/EN 55 022 Statement

This certifies that the Nortel Networks CVX 600 switch is shielded against the generation of radio interference in accordance with the application of Council Directive 89/336/EEC. Conformity is declared by the application of EN 55 022:1998 and EN 55 024:1998.

Warning: This is a Class A product. In a residential area, this product may cause radio interference, in which case the user may be required to take the appropriate measures.

EC Declaration of Conformity

This product conforms to the provisions of Council Directive's EMC Directive (89/336/EEC), Low Voltage Directive (73/23/EEC), and R+TTE Directive (1999/5/EC).

Japan/Nippon Requirements Only

Voluntary Control Council for Interference (VCCI) Statement

この装置は、第一種情報装置（商工業地域において使用されるべき情報装置）で、商工業地域での電波障害防止を目的とした情報処理装置等電波障害自主規制協議会（VCCI）基準に適合しております。

従って、住宅地域、その隣接地域等で使用した場合、ラジオ、テレビ受信機等に障害を与えることがあります。

Voluntary Control Council for Interference (VCCI) Statement

This equipment is in the 1st category (information equipment to be used in commercial and/or industrial areas) and conforms to the standards set by the Voluntary Control Council for Interference by Data Processing Equipment and Electronic Office Machines that are aimed at preventing radio interference in commercial and/or industrial areas.

Consequently, when this equipment is used in a residential area or in an adjacent area thereto, radio interference may be caused to equipment such as radios and TV receivers.

JATE Requirements

This certifies that the Nortel Networks CVX 600 conforms to the standards set by JATE (Japan Approvals Institute for Telecommunications Equipment) as of 06/06/01 with Approval Numbers CD01-0459JP and L01-0145.

Safety Warnings

General Warnings

The following safety warnings apply:

- Mechanical hazards and electrical shock hazards are possible if you remove one or more of the modules. There are no operator-serviceable modules. Only qualified personnel should service this equipment.
- This equipment must be connected to a protective ground according to the instructions in this manual. Improper grounding may result in electrical shock.
- This equipment does not provide safety isolation between any port that is connected to a digital network termination point or any port to which terminal equipment is connected.
- The wall circuit breaker provides the main protection for this equipment. For -48 VDC operation, the equipment must reside on its own circuit with a breaker rated for 20 A.
- Ensure that rack installation does not result in airflow blockage to power supply vents or chassis vents.
- Before installing the CVX 600 switch, ensure that the rack is sturdy and well-secured.

DC Power Supply Warnings

The DC power supply must be installed in a restricted area, such as an equipment closet or room, in compliance with Articles 110-16, 110-17, and 110-18 of the National Electric Code, ANSI/NFPA 70. The DC power source must be isolated from the AC power source and must have a proper ground.

The grounded conductor of the DC supply circuit can be connected to the frame grounding conductor of the CVX 600 switch. In this case, the following conditions apply:

- The CVX 600 switch must be connected to the DC power supply grounded conductor or bonding jumper from the grounding terminal bar or bus to which the DC power supply grounded conductor is connected.
- The CVX 600 switch must be located in the same area as other equipment having a connection between the grounded conductor of the same DC supply circuit and the grounding conductor, and also the point of grounding of the DC system. The DC system must not be grounded elsewhere.
- You must not switch or disconnect devices in the grounded conductor between the DC power supply and the point of connection of the grounding electrode conductor.
- A readily accessible disconnect device may be provided in the fixed wiring for a DC power supply. The device must be rated for the voltage and current specified.
- Before installing equipment in a rack, consider the overall loading of the branch circuit.

For safety purposes, the DC power supply requires connection to a grounded outlet. To prevent possible injury from voltages on the telecommunications network, disconnect all telecommunications network lines before disconnecting the DC power supply from the grounded outlet.

Lithium Battery Caution

Caution: Danger of explosion if battery is incorrectly replaced. Replace only with the same or equivalent type recommended by the manufacturer. Discard used batteries according to the manufacturer's instructions.

Attention: Il y a danger d'explosion s'il y a remplacement incorrect de la batterie. Remplacer uniquement avec une batterie du même type ou d'un type recommandé par le constructeur. Mettre au rebut les batteries usagées conformément aux instructions du fabricant.

Regulatory and Safety

Regulatory Information	iii
U.S.A. Requirements	iii
Australian Requirements	iv
Canadian Requirements	iv
European Requirements	v
Japan/Nippon Requirements Only	vi
Safety Warnings	vii
General Warnings	vii
DC Power Supply Warnings	vii
Lithium Battery Caution	viii

Preface

About This Guide.....	xv
Introduction	xv
Topics	xv
Chapters and Appendixes in This Guide	xvi
Information About CVX Products	xvii
About This Release	xvii
Accessing Related Documentation	xvii
Accessing Software Upgrades	xvii
Customer Services	xviii
Technical Support	xviii
Product Damage	xviii
Equipment Problems	xviii

Chapter 1**Chassis Installation**

About This Chapter.....	1-1
Introduction	1-1
Topics	1-1
CVX 600 Chassis Overview	1-2
Description	1-2
Remote Access Configuration	1-2
Where to Install	1-2
Front View of CVX 600 Chassis	1-3
Rear View of CVX 600 Chassis	1-4
Preparing the Site for the Installation	1-5
Overview	1-5
Reference	1-5
Mounting Options	1-5
Mounting the CVX 600 in a Rack	1-7
Rack Capacity	1-7
Rack Requirements	1-7
Nortel Networks Rack Recommendation	1-7
Rack Placement	1-7
Ceiling Requirements	1-8
Size and Weight Considerations	1-8
Reference	1-8
Nortel Networks PTE 2000 Rack	1-8
Access Considerations	1-11
Rack Cooling Requirements	1-11
AC and DC Power	1-12
Description	1-12
Preparing for the CVX 600 Installation	1-14
Overview	1-14
Unpacking the Shipment	1-14
Checking the Shipment	1-15
Tools and Equipment Needed	1-16

Installing the CVX 600 Chassis	1-18
Mounting Options	1-18
Positioning the Chassis on a Flat Surface	1-18
Installing the Feet on the Bottom of the Chassis	1-19
Mounting the Chassis in a Rack	1-20
Telco and EIA Rack Hole Spacing	1-21
Hardware Needed to Complete the Chassis Installation	1-22
Installing the Chassis	1-23

Chapter 2
Chassis Connections

About This Chapter.....	2-1
Introduction	2-1
Topics	2-1
Connecting Alarms	2-2
Introduction	2-2
Alarm Categories	2-2
Alarm Types	2-3
Reference	2-5
Procedure	2-6
Connecting Network Cables	2-7
Overview	2-7
Reference	2-7
Connecting to 10/100BASE-T Interfaces	2-8
Connecting to DS1/T1 Interfaces	2-9
Connecting to E1 Interfaces	2-10
Connecting to DS3 Interfaces	2-11
Connecting to the HSSI Interface	2-12
Connecting to the OC3/STM1 Interface	2-13

Connecting Power to the Chassis	2-16
Before You Start	2-16
Requirements	2-16
Grounding the Chassis	2-17
Connecting to a Customer-Supplied DC Power Source	2-21
Next Step	2-24
Connecting Chassis to an AC Power Source	2-25
Routing the Cables	2-27
Cable Mounts	2-27
Suggested Use	2-27
Locations of Cable Mounts	2-27
Routing Fiber Optic Cables	2-28
Installing and Removing the Flash Memory Cards	2-29
Description	2-29
Reference	2-29
Inserting a Flash Memory Card	2-30
Removing a Flash Memory Card	2-31
Connecting Equipment to the Console Port	2-32
Introduction	2-32
Connecting a Terminal	2-33
Connecting a PC	2-35
Connecting a Modem	2-37
Connecting a Terminal Server	2-39
Connecting Equipment to a Local Ethernet Port	2-41
Description	2-41
Connecting a Remote Device Using an Ethernet Port	2-41
Applying Power to the CVX 600	2-42
Procedure	2-42

Checking the LEDs	2-43
Introduction	2-43
SCC-SM, SCC-RLTM (Ethernet 10/100 Mb/s ports)	2-44
SCC-HSSI-SM, SCC-HSSI-RLTM	2-46
Optical SCC-II	2-48
Optical DAC	2-51
DAC-SM LEDs	2-52
MAC-SM LEDs	2-54

Chapter 3
Replacing CVX 600 Components

About This Chapter.....	3-1
Introduction	3-1
Topics	3-1
Attaching the Antistatic Wrist Strap	3-2
Location of Wrist Strap	3-2
Purpose of Wrist Strap	3-2
How to Attach the Wrist Strap	3-2
Replacing Modules and Filler Panels	3-4
Introduction	3-4
Removing and Installing Filler Panels	3-4
Replacing the SCC-SM	3-11
Replacing the SCC-LTM/RLTM	3-16
Replacing Other Service Modules	3-21
Replacing the DAC-LTM/-RLTM	3-26
Replacing the Fan Module	3-31
Description	3-31
Removing the Fan Module	3-32
Installing a Fan Module	3-34
Replacing a PDU Module	3-36
Description	3-36
Removing the PDU Module	3-36
Installing a PDU Module	3-38

Replacing a Power Module	3-40
Description	3-40
Removing the Power Module	3-40
Installing a Power Module	3-42
Ordering Replacement Components	3-44
How to Order	3-44

Appendix A
Technical Specifications

About This Appendix	A-1
Introduction	A-1
Topics	A-1
Chassis Specifications and Clearances	A-2
Dimensions, Weight, Slot Capacity	A-2
Clearance	A-2
Environmental Specifications	A-3
Specifications	A-3
Cooling Requirements	A-4
Need for Ventilation	A-4
Methods of Cooling	A-4
Airflow	A-4
Electromagnetic Emissions and Radio Frequency	A-5
CVX 600 Requirements	A-5
Cable Specifications	A-6
Cables Supplied by Nortel Networks	A-6
Cables Supplied by the Customer	A-6
Management Console Cable Specifications	A-7
HSSI Interface	A-9
Ethernet 10/100BASE-TX Interface Cable Specifications	A-11
E1 and T1 Interface Line Specifications	A-12
E1 and T1 Shielded Cable Specifications	A-13
DS3 Coaxial Cable Specifications	A-13
Optical Cable Specifications	A-13

Tandem CVX to RAS CVX Crossover Cable	A-14
Introduction	A-14
Tool and Parts Needed	A-14
Pin Data	A-14
Audible and Visual Alarm Interface Specifications	A-16
Alarm Interface Connector	A-16
Signals	A-16
Reference	A-16
Power Specifications	A-17
Power Options	A-17
AC Power Requirements	A-17
DC Power Requirements	A-17
SCC-LTM/-RLTM Interfaces	A-18
DAC-LTM/-RLTM External Clock Interface	A-19

About This Guide

Introduction

This guide describes how to install the Nortel Networks CVX* 600 Multi-Service Access Switch for Telco and Internet service provider (ISP) customers. Because installation procedures vary between Telco and ISP customers, use this manual as a *guide* for installation.

Topics

This preface covers the following topics:

Topic	Page
Chapters and Appendixes in This Guide	xvi
Information About CVX Products	xvii
About This Release	xvii
Accessing Related Documentation	xvii
Accessing Software Upgrades	xvii
Customer Services	xviii
Technical Support	xviii
Product Damage	xviii
Equipment Problems	xviii

Chapters and Appendixes in This Guide

This guide contains the following chapters and appendixes:

For	Go to
Chassis Installation	Chapter 1
Chassis Connections	Chapter 2
Replacing CVX 600 Components	Chapter 3
Technical Specifications	Appendix A

Information About CVX Products

About This Release

This version of the CVX access switch documentation supports software delivered to customers using CVX Release 5.0 software.

Accessing Related Documentation

For information about gaining access to documentation, contact your Nortel Networks account representative.

Accessing Software Upgrades

Software upgrades are accessible online through the World Wide Web at <http://www.nortelnetworks.com>. Click **Customer Support > Software Distribution** and follow the instructions to download software upgrades for your CVX product.

Access to software upgrades is available to customers with Performance Pack support agreements. Contact your Nortel Networks account representative for more information about Performance Packs or gaining access to software upgrades.

Customer Services

Technical Support

In the USA and Canada: If you are within your warranty period or have purchased a Performance Pack support agreement covering your CVX network, dial 1-800-758-4827 to contact a Technical Support engineer. If you would like information regarding Performance Packs, please contact your Nortel Networks account representative.

Outside the USA: Contact your Regional Nortel Networks Support Prime.

Product Damage

If any part of the CVX 600 is damaged, contact the shipper to conduct an inspection and prepare a damage report. Save the shipping container and all packing materials until the inspection and the damage report are completed.

In addition, contact Technical Support as instructed in the previous section so that arrangements can be made for replacement equipment. Do not return any part of the shipment until you receive detailed instructions from a technical representative.

Equipment Problems

If your equipment is not working properly, you should immediately remove it from the telephone line to prevent any possible damage to the telephone network. If the telephone company identifies a problem, they may notify you prior to discontinuing telephone service. After notification, you will be given an opportunity to correct the problem. You will also be informed of your right to file a complaint with the Federal Communications Commission (FCC).

If repair or modification is required in order for your equipment to operate properly, contact Technical Support. All repairs or modifications must be completed by Nortel Networks or an authorized Nortel Networks representative.

Chapter 1

Chassis Installation

About This Chapter

Introduction

This chapter describes how to install the CVX 600 chassis.

Topics

This chapter covers the following topics:

Topic	Page
CVX 600 Chassis Overview	1-2
Preparing the Site for the Installation	1-5
Mounting the CVX 600 in a Rack	1-7
AC and DC Power	1-12
Preparing for the CVX 600 Installation	1-14
Installing the CVX 600 Chassis	1-18

CVX 600 Chassis Overview

Description

The CVX 600 chassis has 6 slots: 4 slots are reserved for the modem access cards (MACs) and digital access cards (DACs), and 2 slots are reserved for the system control cards (SCCs).

Remote Access Configuration

The CVX 600 chassis configured for remote access is equipped with the following:

- An internal fan module for system cooling
- A redundant DC power interface
- An optional redundant AC power module

Where to Install

You can install the CVX 600 chassis on a flat surface, or you can install it in a Telco or standard EIA 19-inch or 23-inch computer rack.



Note: A 23-inch computer rack requires optional mounting hardware, which you can order from Nortel Networks.

Front View of CVX 600 Chassis

The following figure shows the front of the CVX 600 chassis.

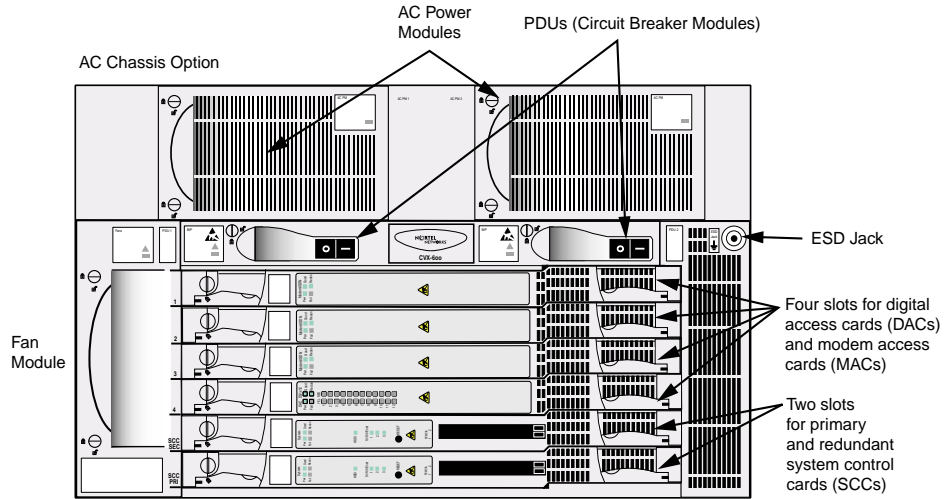

CVX-0218B

Rear View of CVX 600 Chassis

The following figure shows the rear of the CVX 600 chassis.

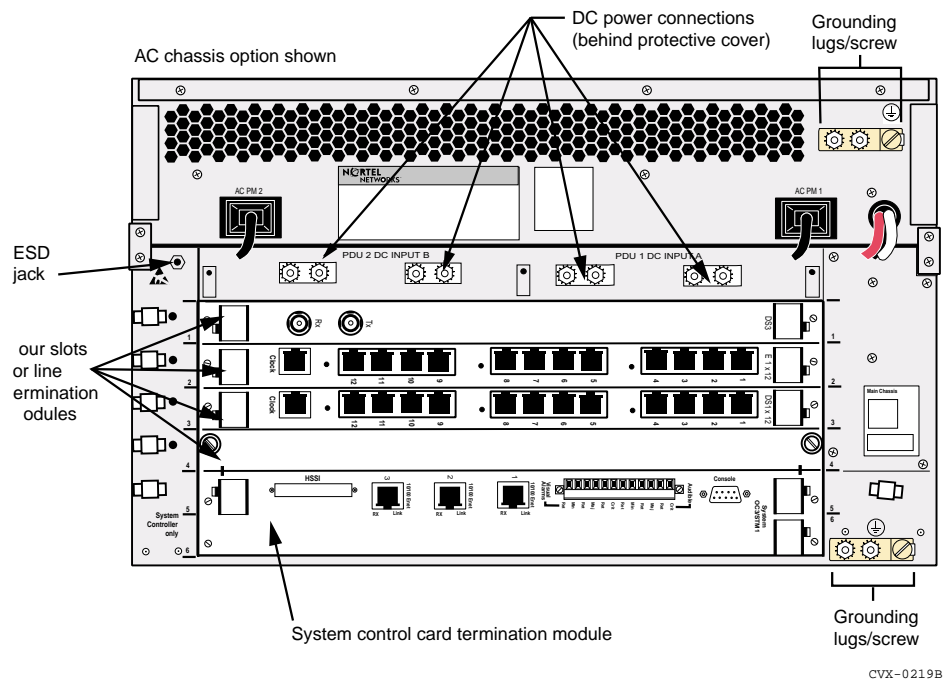

Preparing the Site for the Installation

Overview

Before you install the CVX 600 chassis, you need to prepare your site. Consider the method of mounting (rack or flat surface), the installation of the rack (if used), tools and equipment needed, space requirements, and weight. These issues are addressed in detail in this chapter.

Reference

For information about the environmental requirements and power specifications, see [Appendix A, “Technical Specifications.”](#)

Mounting Options

You can mount the CVX 600 in one of two ways:

- Position the CVX 600 on a flat, sturdy, horizontal surface. See “[Positioning the Chassis on a Flat Surface](#)” on [page 1-18](#).
- Mount the CVX 600 in a rack.

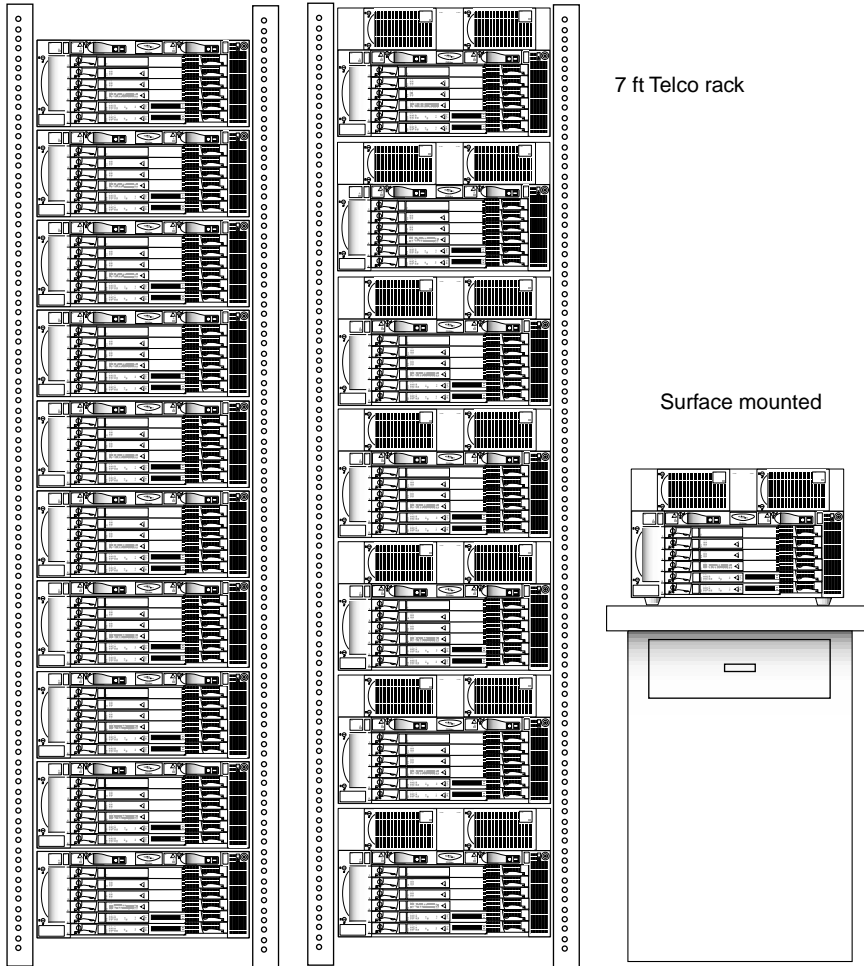

7 ft Telco rack

Surface mounted

CVX-0220A

Mounting the CVX 600 in a Rack

Rack Capacity

You can install up to seven AC-powered CVX 600s or up to ten DC-powered CVX 600s in a standard Telco or Electronic Industries Association (EIA) rack.

Rack Requirements

The rack must meet the following requirements:

- Heavy-duty steel construction
- EIA standard hole spacing, or a Telco rack with 25 mm spacing
- Width of 19 in. (48.26 cm) or 23 in. (58.42 cm), depth of 24 in. (60.96 cm)

Nortel Networks Rack Recommendation

Nortel Networks recommends using a Physical Telecommunications Environment (PTE) 2000 rack.



Caution: Nortel Networks does not authorize the use of racks with front or rear doors or side panels. The operating environment must provide airflow at 200 cubic feet per minute (CFM) per CVX 600 chassis at a temperature range of 32° to 104°F (0° to 40°C). The optimal ambient temperature for reliable CVX 600 operation is 68° to 77°F (20° to 25°C).

Rack Placement

The rack you plan to install should be in an area that is:

- A dedicated equipment room or closet, wired in accordance with local electrical codes
- Large enough to allow easy access for service and maintenance
- Free of dust, smoke, and electrostatic discharge

- Properly ventilated
- Well lighted



Note: The recommended aisle spacing is 29.5 in. (750 mm).

Ceiling Requirements

Consider the following ceiling requirements before you install the rack:

- The ceiling should be clear of obstructions such as beams, heating and air conditioning ducts, water pipes, and lights.
- The ceiling should not have sprinklers; however, appropriate fire protection devices should be available.

Size and Weight Considerations

Before you install the rack at your site, make sure that the equipment room can accommodate the size and weight of the rack and the CVX 600.

To determine the total weight, add the weight of all of the CVX 600 chassis (about 70 lb, 31.7 kg each for the AC chassis option, NTDZ10BA), and the weight of the rack.

Reference

For information about general equipment requirements, see the Telcordia Network Equipment Building Standards (NEBS), *General Equipment Requirements* (GR-63).

Nortel Networks PTE 2000 Rack

Nortel Networks offers two types of PTE 2000 racks:

- PTE 2000 NEBS-compliant rack (NTRU0134)
- PTE 2000 ETSI-compliant rack (NTRU0234)

Reference

For PTE 2000 rack installation instructions, see the *PTE 2000 Installation Guide* (IM 07-08-1543).

Anchor Kits

Nortel Networks offers four types of PTE 2000 anchor kits; each kit contains two anchors. If you do not plan to order anchor kits from Nortel Networks, you can use other anchor kits that provide the same level of seismic protection.



Note: You must use six floor anchors to secure the PTE 2000 rack to the equipment-room floor.

The following table describes each of the anchor kits.

Kit Number	Earthquake Zone Compliance	Floor Type	Notes
NTRU0324	Up to and including zone 4	Raised or concrete floor	Includes M12 anchoring hardware (2 anchors)
NTRU0328	Up to and including zone 4	Concrete floor only	Includes M12 anchoring hardware (2 anchors)
NTRU0323	Up to and including zone 2	Raised or concrete floor	Includes 3/8 in. anchoring hardware (2 anchors)
NTRU0326	Up to and including zone 2	Concrete floor only	Includes 3/8 in. anchoring hardware (2 anchors)

Space Requirements

The following table lists the PTE 2000 racks and dimensions.

Rack Type	Part Number	Width in Inches (mm)	Depth in Inches (mm)	Height in Inches (mm)
NEBS-compliant rack	NTRU0134	23.6 (600)	23.6 (600)	83.66 (2125)
ETSI-compliant rack	NTRU0234	23.6 (600)	23.6 (600)	86.6 (2200)

Flooring Requirements

You must anchor the PTE 2000 rack to the equipment-room floor. The flooring can be one of the following types:

- Raised floor tiles, ideally with a clearance of 18 in. (45.5 cm), and a subfloor cable management system
- Bare concrete floor

Depth for Drilling

If you plan to install the PTE 2000 floor anchors on a bare concrete floor, you must drill to the following depths:

- 2 in. (51 mm) for the 3/8 in. anchor (for zone 2 earthquake compliance, NTRU0323/NTRU0326)
- 4 in. (103 mm) for the M12 anchor (for zone 4 earthquake compliance, NTRU0324/NTRU0328)



Warning: Before you begin to drill, make sure you are familiar with the building construction. If you plan to drill holes in a below-ground structure, make sure that you do not drill through the concrete into the vapor barrier. If you do, groundwater may seep through the anchor hole.

Access Considerations

The doorways, corridors, and elevators leading to the installation site must be able to accommodate the rack. Consider the following when planning the arrival and unloading of the PTE 2000 rack:

- Including the pallet on which the PTE 2000 rack is shipped, the height of the rack is 91.66 in. (2,325 mm). The pallet width is 39.4 in. (1,000 mm).
- The weight of an empty PTE 2000 rack is approximately 125 lb (57 kg), excluding the shipping crate.
- Use freight elevators (if available) to move the equipment to upper floors.

Rack Cooling Requirements

You can install up to seven AC-powered CVX 600s or up to ten DC-powered CVX 600s in a standard Telco or EIA rack without front or rear doors or side panels. Nortel Networks recommends using a PTE 2000 rack.

To ensure proper cooling for the CVX 600, the rack must meet the following requirements:

- The operating environment must provide airflow at 200 CFM per CVX 600 chassis at a temperature range of 32° to 104°F (0° to 40°C).
- The optimal ambient temperature for reliable long-term CVX 600 operation is 68° to 77°F (20° to 25°C).

AC and DC Power

Description

The CVX 600 uses either an AC or DC power source.

AC Power Option

If you are using AC power from an outlet, you should be installing the AC chassis option. The AC chassis option contains two independent power modules. If one module fails, the other module powers the CVX 600.

AC Chassis Option

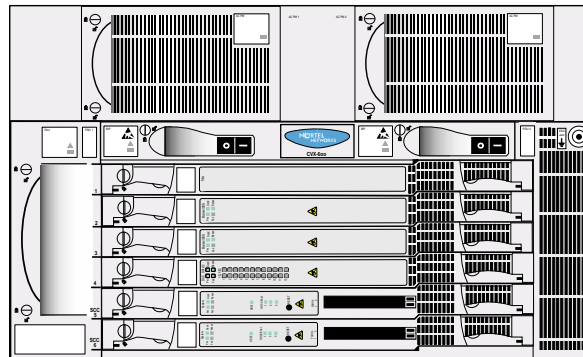

CVX-0237B

DC Power Option

If you are using an external AC power supply, you should be installing the DC chassis option.

The DC chassis option requires an external -48 VDC power source.

DC Chassis Option

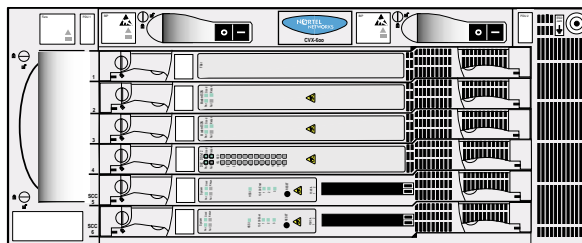

CVX-0238B



Note: Both versions contain internal circuit breaker modules.

Preparing for the CVX 600 Installation

Overview

To prepare for the installation of the CVX 600 chassis, make sure:

- The shipment is complete and undamaged.
- You have the proper equipment and tools.
- You have network lines available.

Unpacking the Shipment

The CVX 600 is secured to a pallet and covered by a box to protect the contents during shipment. Move the shipping container to the installation site before unpacking the CVX 600.

To unpack the CVX 600, follow these steps:

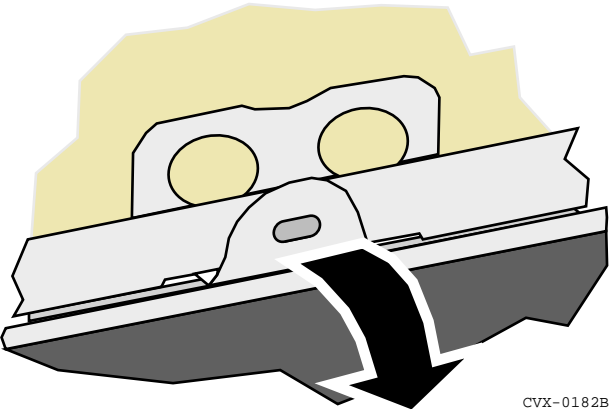
Step	Action
1	<p>Using a screwdriver or other tool, pry down the tabs that secure the box to the pallet.</p>  <p>CVX-0182B</p>
2	Lift the box up and off the pallet.

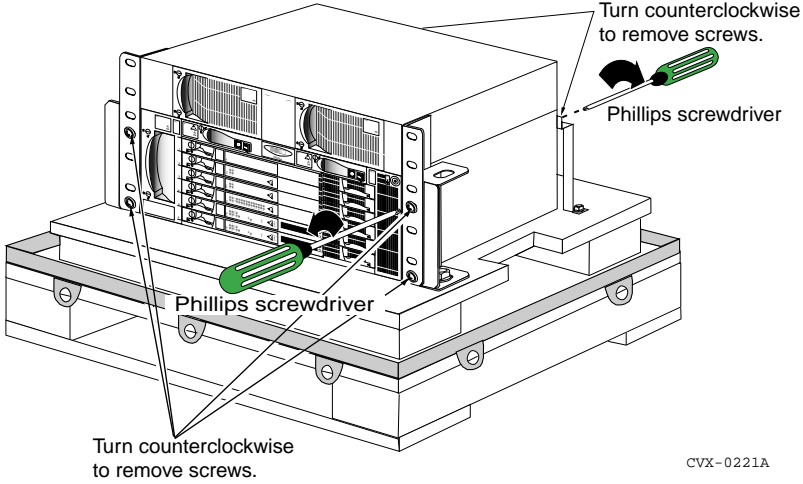
Step	Action
3	Remove the box containing the accessory kit and other parts. (The AC chassis option will have two power cords. The DC chassis option will have none.)
4	Remove the packing material surrounding the chassis.
5	Using a Phillips screwdriver, remove the six screws that secure the chassis to the pallet brackets. <div style="text-align: center; margin-top: 10px;">  <p style="text-align: right; margin-right: 50px;">Turn counterclockwise to remove screws.</p> <p style="text-align: right; margin-right: 50px;">Phillips screwdriver</p> <p style="text-align: center;">Phillips screwdriver</p> <p style="text-align: center;">Turn counterclockwise to remove screws.</p> <p style="text-align: right; margin-right: 50px;">CVX-0221A</p> </div>
6	Using a 9/16-inch wrench, remove the four bolts that secure the pallet brackets to the pallet.
7	Remove the four pallet brackets from the pallet.
8	Carefully remove the chassis from the pallet.

Checking the Shipment

Carefully inspect the shipment for completeness, ensuring the items in the shipping container match those on the packing list affixed to the shipping container. In particular:

- Confirm that the shipment includes any additional cables you have ordered.
- Check all items for shipping damage.



Note: If you detect or suspect any damage, do not install the CVX 600 chassis. See [“Technical Support”](#) on [page xviii](#).

Tools and Equipment Needed

Before you install the CVX 600 chassis, ensure that you have all of the necessary tools, cables, console equipment, and mounting hardware.

Tools

You must have the following tools:

- Screwdrivers:
 - Phillips #2 screwdriver
 - 1/16-inch and 1/4-inch flat-tip screwdrivers
- Nut drivers (nonmetric sizes) for securing power and ground cabling
- Volt/ohm meter for power connections

Cables and Cable Ties

The shipment does *not* include the cables required for the telephone side of your network. Ensure that the installation site has the proper network cabling.

Cable ties are needed to bundle network and power cables, to provide access to LTM and RLTM modules.

Service Console

You can connect a local terminal or a PC to the CVX 600 to monitor startup diagnostics and to perform manual startup and configuration. See [Chapter 2, “Chassis Connections,”](#) for information on installing a service console. See the following software manuals for information on configuring the CVX 600 access switch:

- *CVX Multi-Service Access Switch Startup Guide*
- *CVX Multi-Service Access Switch Configuration Guide*



Note: Before you turn on the CVX 600, you should connect a local terminal or PC to the CVX 600 console port. This console will display diagnostic information. If there is a startup problem, in which case, you need to contact Nortel Networks Technical Support (see “[Customer Services](#)” on [page xviii](#)).

Mounting Hardware

To install the CVX 600 chassis in a rack, you need a Phillips #2 screwdriver and a computer rack that meets the specifications listed in “[Rack Requirements](#)” on [page 1-7](#).

If the rack does not have threaded rail holes, you must use cagenuts and cagenut screws (not supplied).

Installing the CVX 600 Chassis

Mounting Options

You can mount the CVX 600 in one of two ways:

- Position the chassis on a flat, sturdy, horizontal surface.
- Mount the chassis in a rack.

Positioning the Chassis on a Flat Surface

When positioning the chassis on a flat, sturdy surface, you must ensure that the surface is:

- Large enough for the chassis to operate properly
- Strong enough to support the combined weight of the chassis and the cables

Installing the Feet on the Bottom of the Chassis

To install the feet, follow these steps:

Step	Action
1	Carefully lay the chassis on one side.
2	Using a Phillips screwdriver, attach the feet to the four holes in the bottom of the chassis, near the corners.

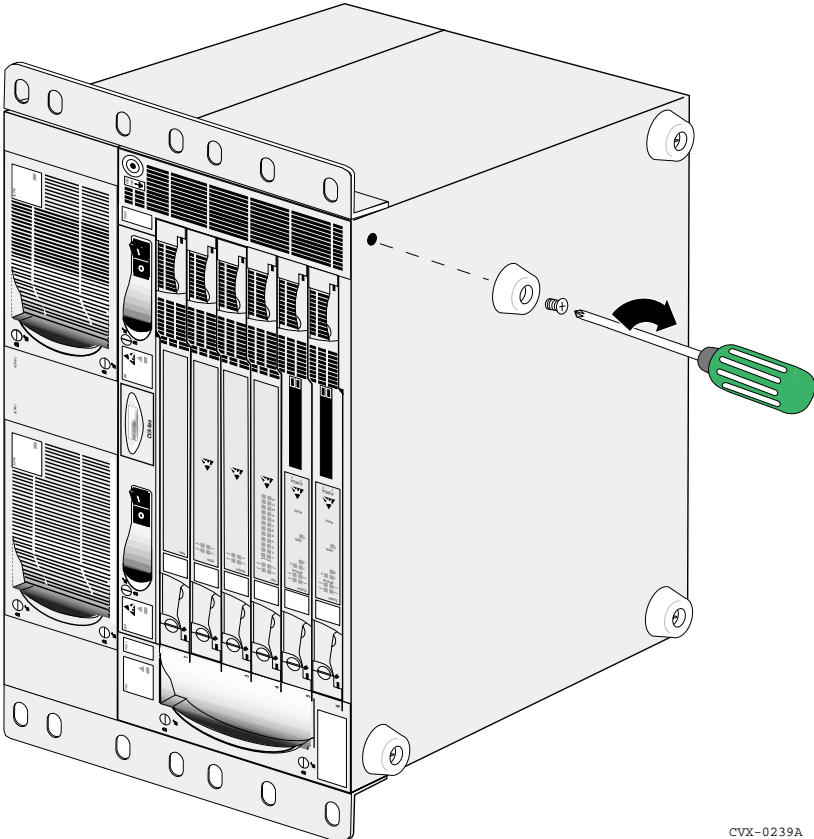

CVX-0239A

Mounting the Chassis in a Rack

The mounting flanges are preinstalled on the chassis.



Caution: Nortel Networks recommends using a PTE 2000 rack. Nortel Networks does not authorize the use of racks with front or rear doors or side panels. The operating environment must provide airflow at 200 cubic feet per minute (CFM) per CVX 600 chassis at a temperature range of 32° to 104°F (0° to 40°C). The optimal ambient temperature for reliable CVX 600 operation is 68° to 77°F (20° to 25°C).



Caution: Before you install the CVX 600 chassis in a rack, ensure that the rack is sturdy and well secured. A fully configured CVX 600 chassis weighs about 70 lb, which could make an unsecured rack top-heavy or unstable.

Telco and EIA Rack Hole Spacing

You can use mounting flanges to install the CVX 600 chassis in a Telco or EIA rack. Telco and EIA racks have 0.5-inch spacing between the dual mounting holes, and 0.625-inch spacing between the dual mounting hole pairs.

The following figure shows the positions on the mounting flange that you use for Telco and EIA racks.

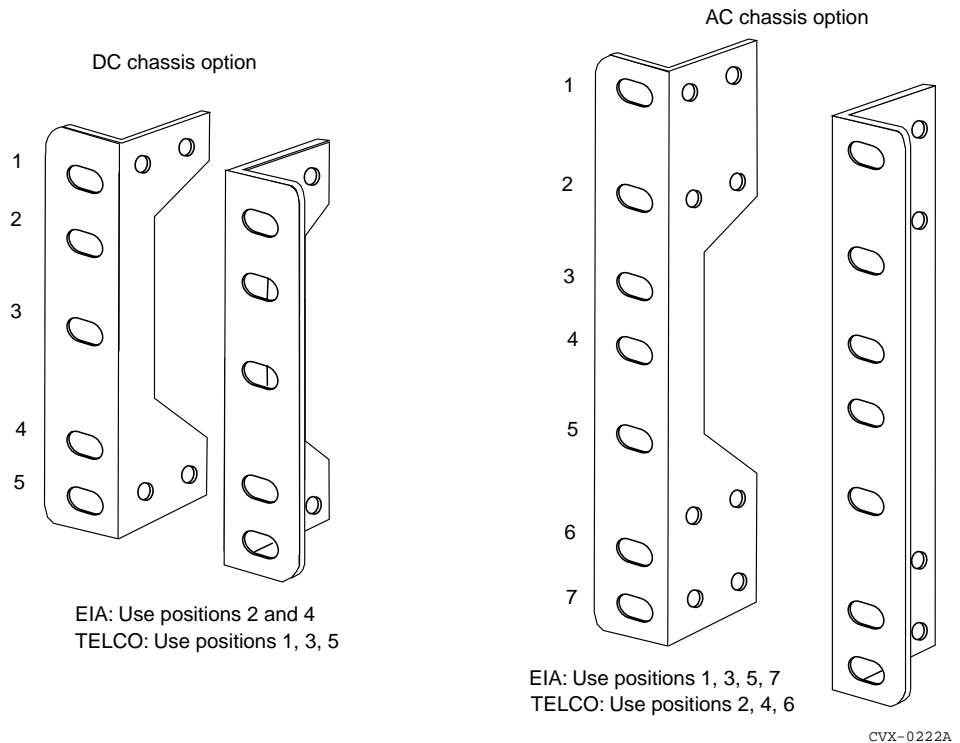

Note: Before you install the CVX 600 chassis in a rack, determine the type of rack you have so that you can properly align the mounting holes.

Hardware Needed to Complete the Chassis Installation

To complete the chassis installation, you need the following hardware:

- Four (for DC chassis option) or eight (for AC chassis option) truss-head mounting screws (included in the shipment)
- Phillips #2 screwdriver



Caution: A fully configured CVX 600 chassis can weigh about 70 lb. You should have someone assist you in lifting and holding the chassis in position at installation time.

Installing the Chassis

To install the chassis, follow these steps:

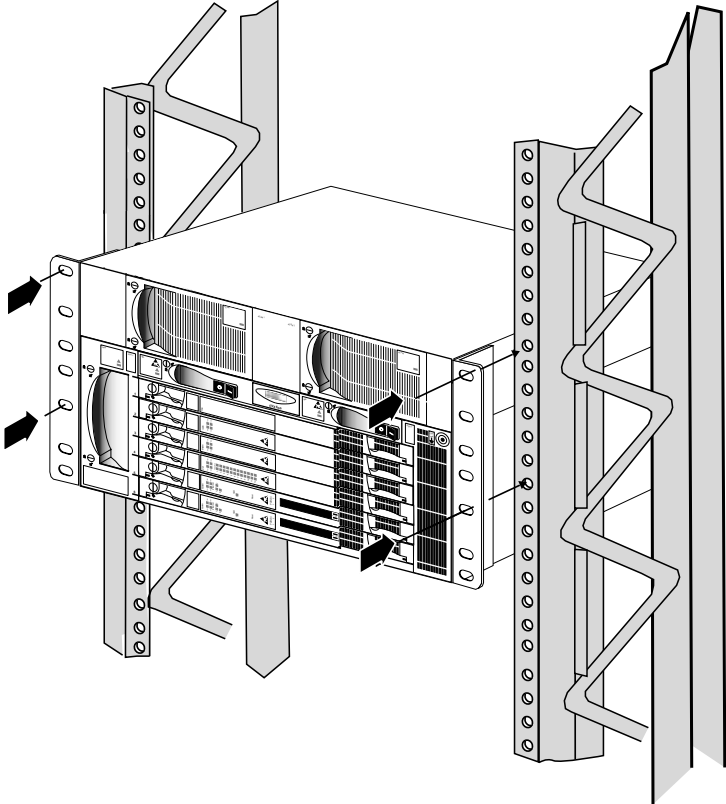
Step	Action
1	Have someone help you lift the chassis to the desired installation height.
2	<p>Move the chassis up or down to properly align the positions on the mounting flanges with the mounting holes on the rack.</p>  <p>CVX-0240A</p>

(continued)

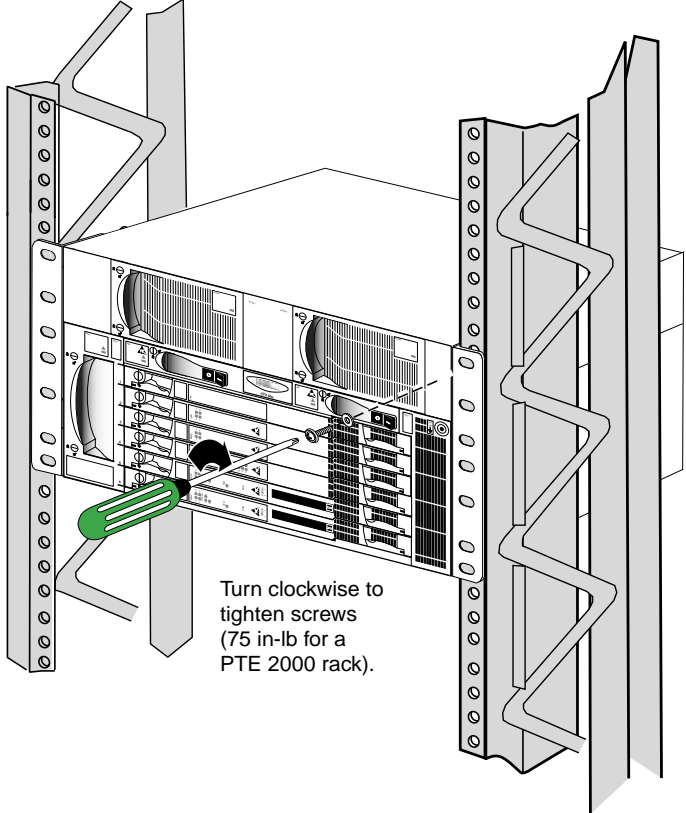
Step	Action
3	<p data-bbox="458 249 1276 309">Insert truss-head screws through each flange hole and into the corresponding holes on the front vertical supports of the rack.</p>  <p data-bbox="743 904 911 1003">Turn clockwise to tighten screws (75 in-lb for a PTE 2000 rack).</p> <p data-bbox="1100 1147 1196 1164">CVX-0241A</p>
4	<p data-bbox="458 1192 962 1216">Use a Phillips screwdriver to tighten the screws.</p> <p data-bbox="458 1251 1276 1385">Caution: You must tighten the screws sufficiently to support the CVX 600 chassis. If using the PTE 2000 rack, tighten the provided hex-head screws to 75 in-lb, using a torque-regulating ratchet. Nortel Networks cannot recommend a specific torque value for other racks.</p>

Chapter 2

Chassis Connections

About This Chapter

Introduction

This chapter describes how to connect network cabling and optional console equipment to the CVX 600.

Topics

This chapter covers the following topics:

Topic	Page
Connecting Alarms	2-2
Connecting Network Cables	2-7
Connecting Power to the Chassis	2-16
Routing the Cables	2-27
Installing and Removing the Flash Memory Cards	2-29
Connecting Equipment to the Console Port	2-32
Connecting Equipment to a Local Ethernet Port	2-41
Applying Power to the CVX 600	2-42
Checking the LEDs	2-43

Connecting Alarms

Introduction

The SCC-LTM and SCC-RLTM contain a terminal block that allows you to connect up to three audible alarms and three visual alarms. These alarms alert you to critical, major, and minor conditions. The left six screw terminals on the terminal block are available for visual alarms, such as lights; the right six screw terminals are available for audible alarms, such as bells.



Warning: The contacts on the terminal block are rated at 30 VAC and have a maximum current rating of 1 ampere (A). The circuit connecting the alarms must meet the requirements for safety extra-low voltage (SELV). The wires connecting the alarms must be the appropriate gauge for alarm devices.

During normal, uninterrupted operation, the contacts remain open. If a failure occurs, the contacts close and trigger the connected alarm.

Alarm Categories

The following table lists the three general categories of alarms and the possible causes:

Alarm	Possible Cause
Critical (Crit)	Hardware failures: the system power supply and fan module have failed, for example.
Major (Maj)	Communication failures: the link or network connection has failed.
Minor (Min)	Modem failures: the configured thresholds have been exceeded.

Alarm Types

The following table lists specific alarm types, severity, and possible causes:

Alarm Type	Severity	Description
T1 Alarm	Critical	An alarm condition has been detected on the specified T1 line, or the signal on the T1 line has been lost.
T3 Alarm	Critical	An alarm condition has been detected on the specified T3 line, or the signal on the T3 line has been lost.
HSSI Port Down	Critical	The HSSI port has failed to initialize.
Ethernet Port Down	Major	The Ethernet port has failed to initialize.
Fan Down	Major	The cooling fans have stopped.
Power Down	Major	The external power source has dropped.
SCC Failover	Major	The primary SCC has failed, and the secondary SCC has resumed operation. CVXView generates this alarm. Although the raising trap is generated on the CVX 600, it does not recognize this as an alarm condition. This alarm must be cleared manually on CVXView (Clear Alarms button).
Link Down	Minor	The sending protocol entity recognizes a failure in one of the communication links represented in the agent's configuration.
Slot Down	Minor	Communication has been lost between the indicated slot and the SCC.
Sonet/SDH Loss of Signal	Major	Transitions are not detected on incoming signals, therefore, a loss of signal is declared.
Sonet/SDH Loss of Frame	Major	An OOF/SEF defect has persisted for a period of 3 milliseconds, therefore, a loss of frame is declared.
Sonet/SDH C2 Mismatch	Minor	The C2 field value in the received frame does not match the configured value in the SigLabelExpect attribute.
Sonet/SDH S1 New Event	Minor	The specified STM-1 is in S1 New Alarm. The S1 field in the received frame contains a new value.

(continued)

Connecting Alarms

Alarm Type	Severity	Description
Sonet/SDH S Trace Mismatch	Minor	The Section Trace string in the received frame does not match the configured value in the StraceStringExpect attribute.
Sonet/SDH P Trace Mismatch	Minor	The Path Trace string in the received frame does not match the configured value in the PtraceStringExpect attribute.
Sonet/SDH LOS Alarm Clear	Major	The LOS alarm condition is cleared.
Sonet/SDH LOF Alarm Clear	Major	The LOF alarm condition is cleared.
APS Live	Minor	The designated optical interface is up and can receive calls.
APS Standby	Minor	The designated optical interface is up, but is in standby mode.
APS Down	Minor	The designated optical interface is down.
ATM Red Alarm	Major	The specified link port has a critical alarm, such as the absence of a line signal.
ATM Yellow Alarm	Major	The specified link port has an informational alarm.
ATM Alarm Clear	Major	The specified link port alarms are cleared.
ATM Marker Port Up	Minor	The STIC Marker port is up.
ATM Marker Port Down	Minor	The STIC Marker port is down.
ATM Interface Up	Minor	The ATM interface is up.
ATM Interface Down	Minor	The ATM interface is down.
ATM Logical Interface Up	Minor	The logical interface on the ATM interface is up.
ATM Logical Interface	Minor	The logical interface on the ATM interface is down.
ATM ILMI Enabled	Minor	The ILMI interface is up.
ATM ILMI Disabled	Minor	The ILMI interface is down.

Alarm Type	Severity	Description
ATM PVPC PVCC Up	Minor	The PVPC/PVCC has been successfully created.
ATM PVPC PVCC	Minor	The PVPC/PVCC is down.
ATM APS Switchover	Minor	A link failure caused the PHY driver to turn on the redundant PHY.
Sonet/SDH Alarm Sdber	Major	The specified STM-1 is in Signal Degrade Bit Error Rate alarm. The value set in the SigDegradeThreshold attribute for this line has been exceeded.
Sonet/SDH Alarm Sfber	Major	The specified STM-1 is in Signal Failure Bit Error Rate alarm. The value set in the SigFailureThreshold attribute for this line has been exceeded.
Sonet/SDH Alarm Sdber Clear	Major	The specified STM-1 is not in Signal Degrade Bit Error Rate alarm. The Signal Degrade Bit Error Rate is now below the SigDegradeThreshold value set in the configuration.
Sonet/SDH Alarm Sfber Clear	Major	The specified STM-1 is not in Signal Failure Bit Error Rate alarm. The Signal Failure Bit Error Rate is now below the SigFailureThreshold value set in the configuration.

Reference

For pinout assignments, see [Appendix A, “Technical Specifications.”](#)

Procedure

To connect alarms to the terminal block, follow these steps:

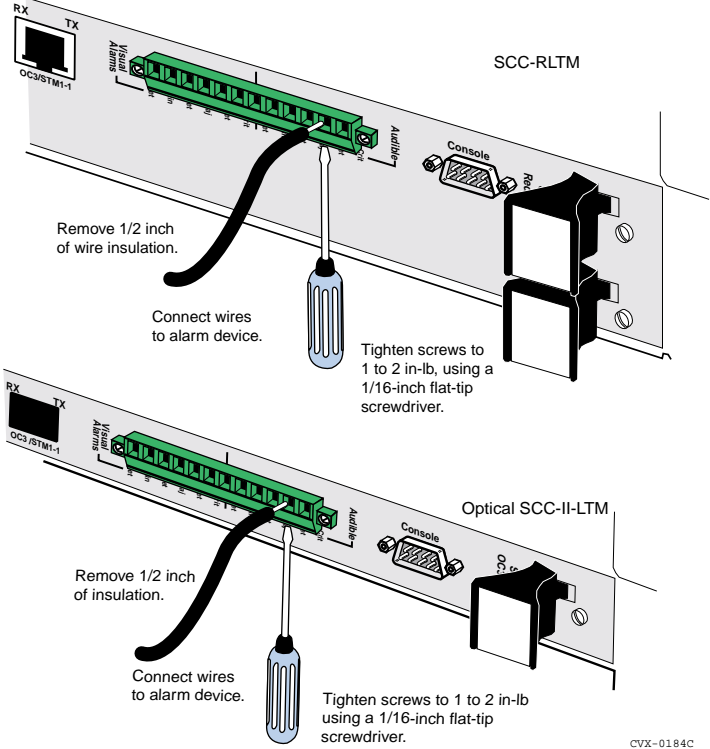
Step	Action
1	Select the terminals you want to use for the audible or visual alarm.
2	<p>Use a small flat-tip screwdriver to loosen the two terminal screws for each alarm device you want to connect. For example, if you want to connect an audible alarm for a critical condition, loosen the terminal screws for the terminals labeled Crit(ical) and Ret(urn).</p> 
3	Use a wire stripper to remove approximately 1/2 inch of insulation from the wires.
4	Insert the wires into the terminals and tighten the screws to 1 to 2 in-lb using a 1/16-inch flat-tip screwdriver.
5	Connect the other end of the wires to the alarm device.

Connecting Network Cables

Overview

You will need to attach network cables to the following CVX 600 interfaces:

- 10/100BASE-T (on the SCC-LTM and SCC-RLTM)
- DS1/T1 (RJ-45/48C)
- E1 (RJ-45/48C)
- DS3
- HSSI
- Optical (OC3/STM1)

Reference

See [Appendix A, “Technical Specifications”](#) for descriptions of the CVX 600 cable interfaces.

Connecting to DS1/T1 Interfaces

The DS1-DAC-LTM provides 12 or 24 channelized T1 ports and one port for connecting to an external clocking device.

To connect T1 cables to the T1 ports, and to connect the DS1-DAC-LTM to an external clocking device, follow this step:

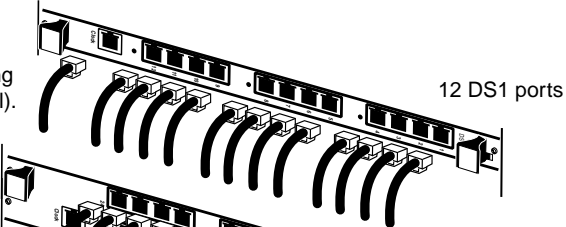
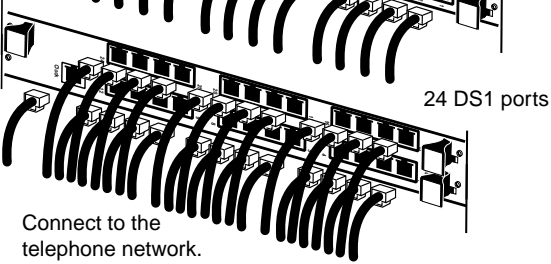
Step	Action
1	<p data-bbox="458 531 886 557">Plug the connectors into the receptacles.</p> <div data-bbox="519 604 682 682"><p>Connect to the external clocking device (optional).</p></div> <div data-bbox="668 569 1228 795"></div> <div data-bbox="486 791 649 869"><p>Connect to the external clocking device (optional).</p></div> <div data-bbox="668 713 1213 977"></div> <div data-bbox="1143 973 1233 991">CVX-0242A</div>

Connecting to E1 Interfaces

The E1-DAC-LTM provides 12 or 24 E1 ports and one port for connecting to an external clocking device. To connect E1 cables to the E1 ports, and to connect the E1-DAC-LTM to an external clocking device, follow this step:

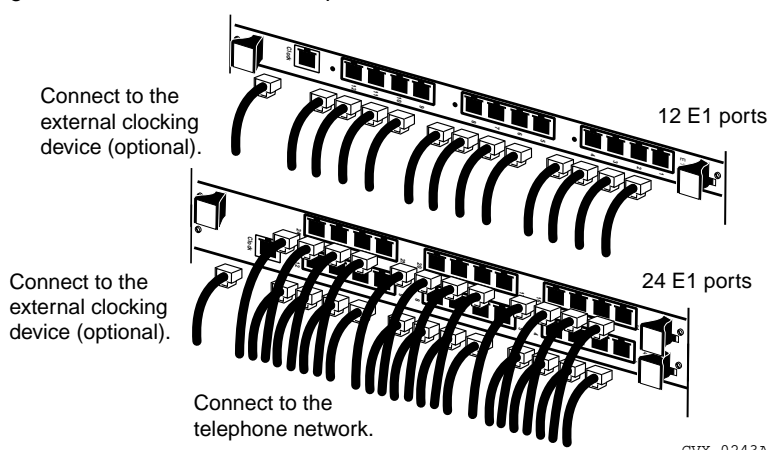
Step	Action
1	<p>Plug the connectors into the receptacles.</p>  <p>Connect to the external clocking device (optional).</p> <p>12 E1 ports</p> <p>Connect to the external clocking device (optional).</p> <p>24 E1 ports</p> <p>Connect to the telephone network.</p> <p>CVX-0243A</p>



Note: Using shielded cabling is an electromagnetic interference (EMI) requirement for CVX 600 E1 network configurations.



Note: For UK installations using 75 ohm E1 coax, a balun is needed to connect to the 120 ohm impedance of the CVX switch. Nortel does not recommend a specific balun panel for this application.

Connecting to DS3 Interfaces

To connect to DS3 interfaces, follow this step:

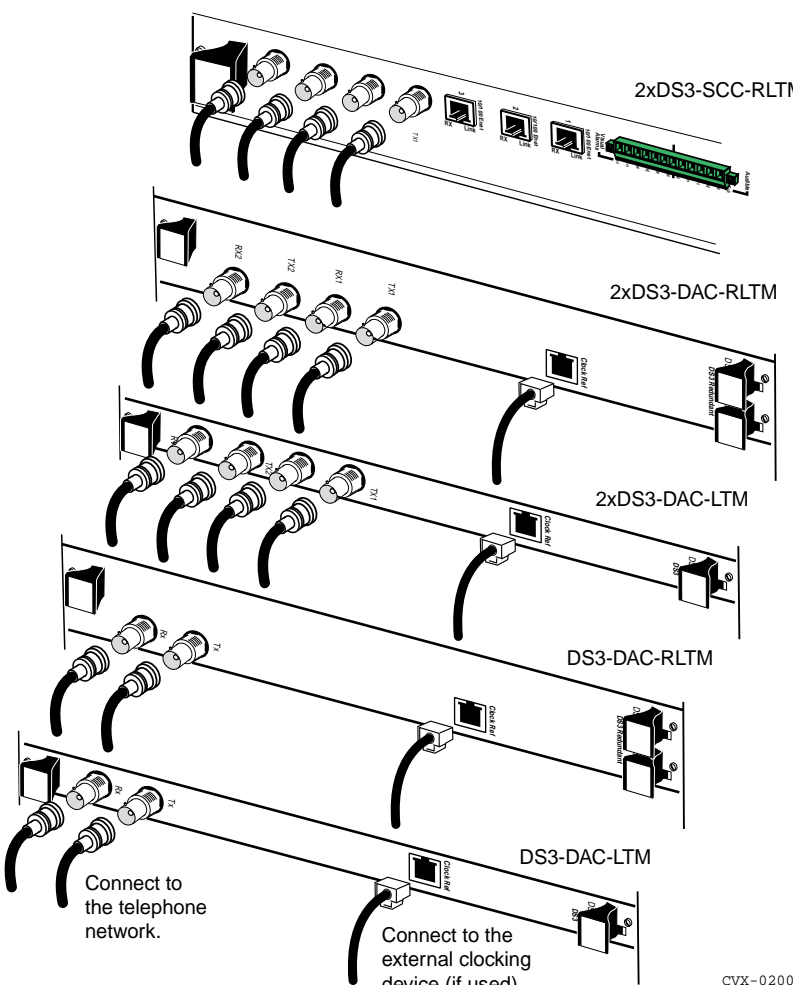
Step	Action
1	<p>Plug the TX and RX coaxial cable connectors into the appropriate DS3 receptacles on the SCC or DAC.</p>  <p>The diagram illustrates the connection of DS3 cables to various interface cards. The cards shown are:</p> <ul style="list-style-type: none"> 2xDS3-SCC-RLTM: Shows TX and RX connectors and network ports. 2xDS3-DAC-RLTM: Shows TX and RX connectors, network ports, and a clock input. 2xDS3-DAC-LTM: Shows TX and RX connectors, network ports, and a clock input. DS3-DAC-RLTM: Shows TX and RX connectors, network ports, and a clock input. DS3-DAC-LTM: Shows TX and RX connectors, network ports, and a clock input. <p>Additional labels include "Connect to the telephone network." and "Connect to the external clocking device (if used)."</p> <p style="text-align: right;">CVX-0200A</p>

Connecting to the HSSI Interface

The SCC-HSSI-RLTM contains one HSSI 50-pin interface receptacle. To connect a HSSI cable, follow this step:

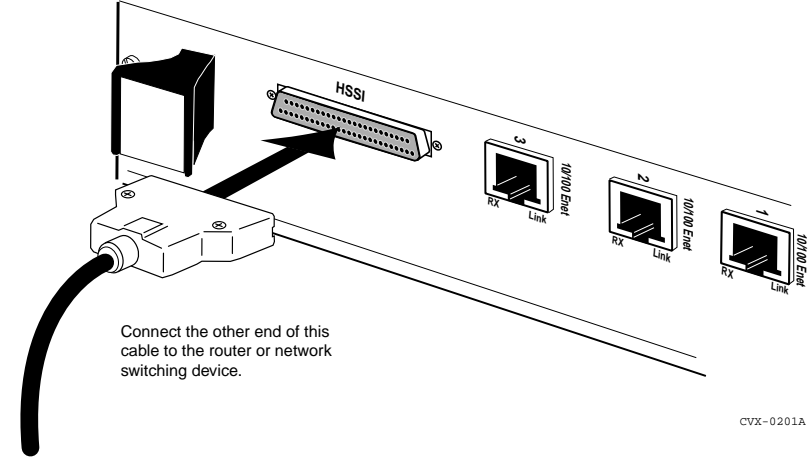
Step	Action
1	<p data-bbox="458 427 1086 453">Plug the cable connector into the HSSI interface receptacle.</p>  <p data-bbox="572 791 786 852">Connect the other end of this cable to the router or network switching device.</p> <p data-bbox="1186 887 1258 904">CVX-0201A</p>

Connecting to the OC3/STM1 Interface

The Optical DAC-LTM contains two sets of optical ports (two primary and two redundant, each with separate Tx and Rx channels), consisting of a total of eight optical connections. The Optical SCC-II-LTM contains two sets, with separate Tx and Rx channels, consisting of a total of four optical connections.

Connections may be made to optical cables with SC single or SC duplex connectors.



Warning: These devices contain Class 1 laser products, and comply with 21 CFR 1040.10 and 1040.11 EN 60825-1 - Safety of Laser Products.

Class 1 lasers are considered eye-safe; however, follow these appropriate safety measures:

- Always make sure that the CVX switch is powered down before connecting or disconnecting any optical cables.
 - Always make sure all ports or unconnected optical cable ends are covered before powering up the CVX switch.
 - Never remove a cover from a port or attached optical cable while the CVX switch has power.
-



Caution: For proper operation, observe the following:

- Never touch the end of the fiber in a connector with anything except an approved cleaner.
 - Always clean the end of the fiber in connectors and optical ports before connecting the cables. Use an approved cleaner, or a soft cloth with isopropyl alcohol.
 - Never use any optical cable that has been damaged, or that has been coiled tighter than a 35-mm radius curve.
-

Connecting an Optical Cable

To connect an optical cable, follow these steps:

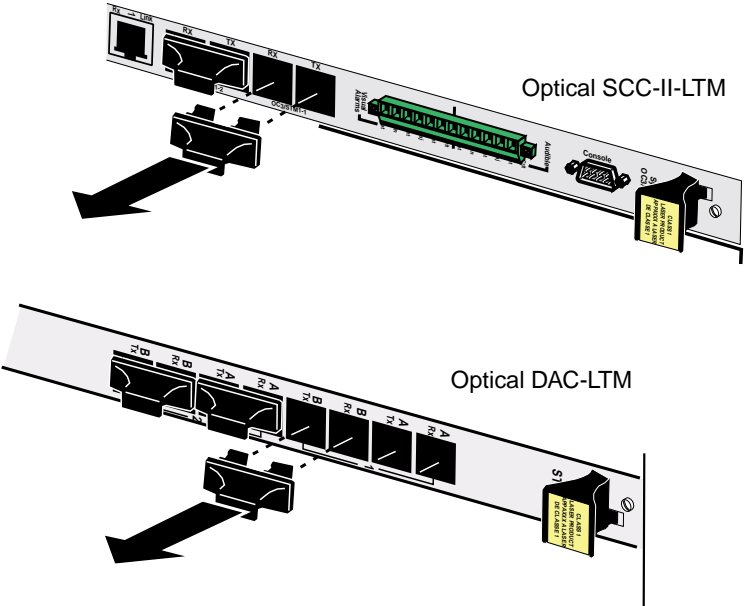
Step	Action
1	<p data-bbox="529 383 1048 413">Remove the rubber plugs from each pair of ports.</p>  <p>The diagram illustrates the removal of rubber plugs from two types of optical modules: Optical SCC-II-LTM and Optical DAC-LTM. In the top diagram, the Optical SCC-II-LTM module is shown with a rubber plug being removed from a port labeled 'TX'. The bottom diagram shows the Optical DAC-LTM module with a rubber plug being removed from a port labeled 'A'. Both diagrams include a large black arrow pointing to the left, indicating the direction of the plug's removal. The modules are shown in perspective, with their respective labels 'Optical SCC-II-LTM' and 'Optical DAC-LTM' placed to the right of each. The DAC-LTM module also has a label 'S' near its base. The document reference 'CVX-0139D' is located in the bottom right corner of the table's action cell.</p>

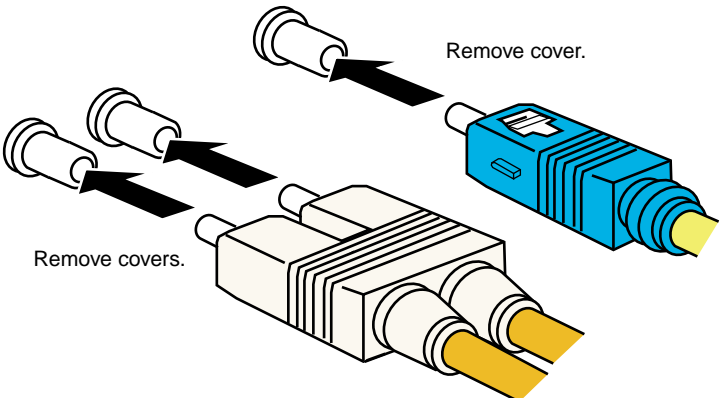
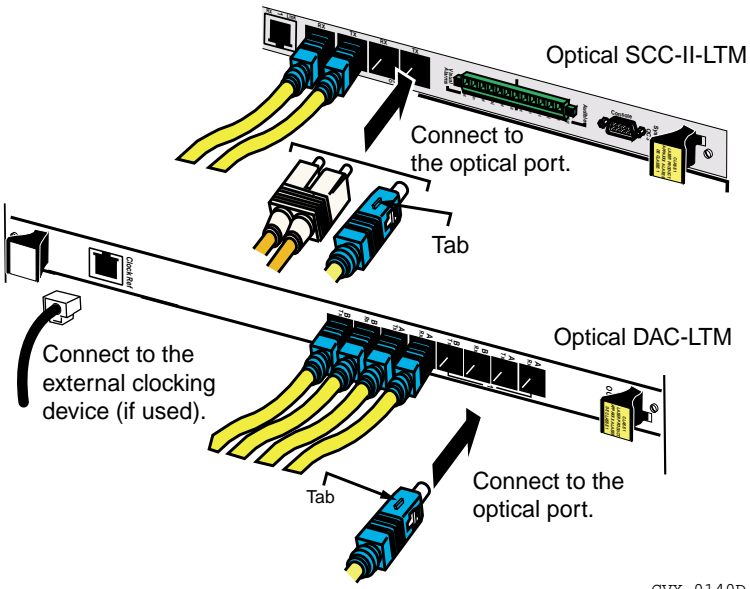
Step	Action
2	<p>Remove the protective covers from each optical connector.</p>  <p style="text-align: right;">CVX-0138B</p>
3	<p>Orient the the optical cable connector so that the tab aligns with the slot in the port, and push the cable connector into the port.</p>  <p style="text-align: right;">CVX-0140D</p>

Connecting Power to the Chassis

Before You Start

Make sure you can power the CVX 600 using one of the following power sources:

- A customer-supplied DC power source with frame grounding (for the DC chassis option)
- A built-in AC power module (for the AC chassis option)

Requirements

Before you connect the CVX 600 to power and ground at the installation site:

- Refer to your company or site specifications for information on the torque requirements for securing power and ground cables.
- Make sure the switches on both circuit breaker modules (PDUs) are off (o).

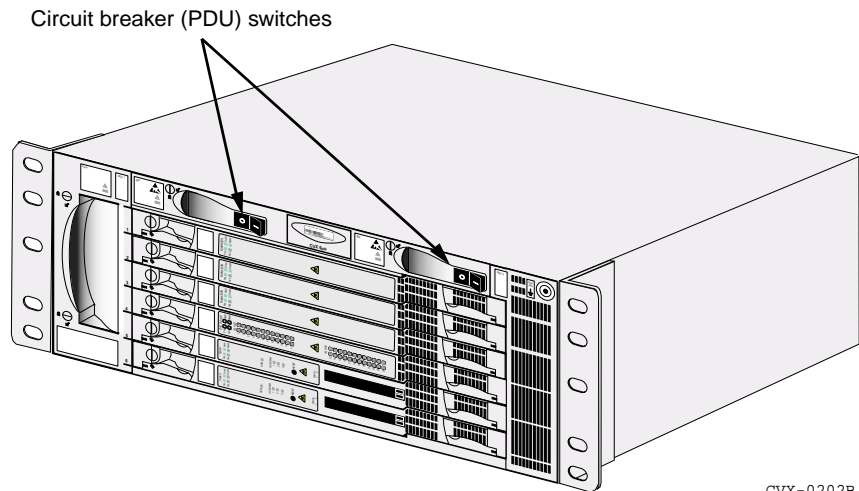

- Read the “[Safety Warnings](#)” on [page vii](#).

Grounding the Chassis



Note: In addition to the grounding location shown in the following sections, the AC chassis option also contains an identical grounding location in the upper right corner of the rear of the chassis. Either location may be used.

There are two ways to ground the CVX 600 chassis:

- Use the NEBS-compliant dual-connector posts.

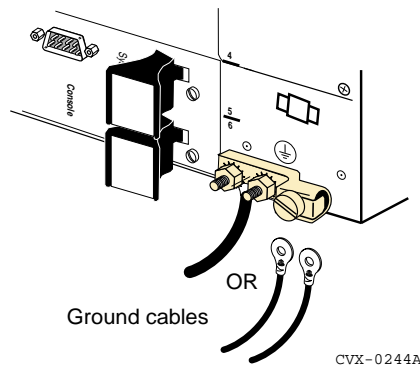

- Use the compression terminal.

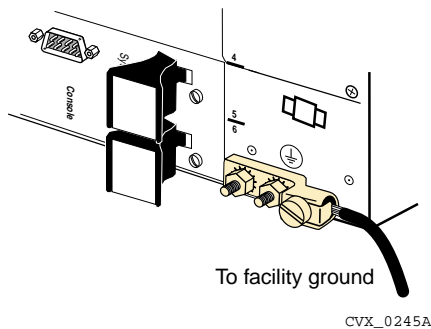

Using the NEBS-Compliant Dual-Connector Posts



Note: In addition to the grounding location shown in the following section, the AC chassis option also contains an identical grounding location in the upper right corner of the rear of the chassis. Either location may be used.

To ground the CVX 600 chassis using the NEBS-compliant dual-connector posts, follow these steps:

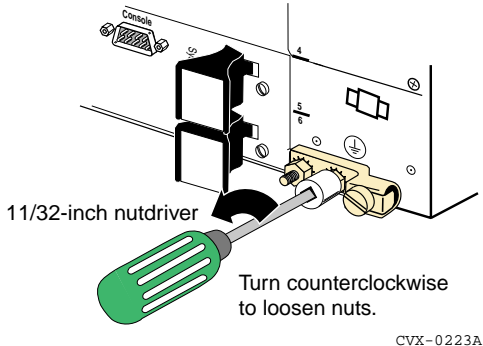
Step	Action
1	Locate a suitable ground cable at your facility.
2	On the back of the chassis, locate the posts with the ground symbol.
3	Remove the #8 locking nuts, using a 11/32-inch nut driver to loosen the nuts. 
4	Remove the connector assembly from the posts if you are using a ground cable with a NEBS-compliant ground fitting.

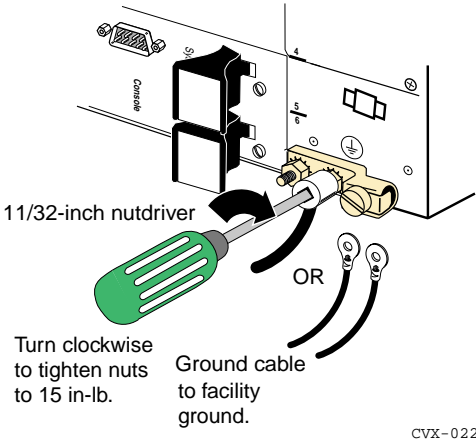
Step	Action
5	<p>Place the grounding connectors over the posts, then secure the connectors using a 11/32-inch nut driver to tighten the #8 locking nuts to 15 in-lb.</p>  <p style="text-align: right;">CVX-0224A</p>
6	<p>Ensure that the other end of the ground cable is properly connected for frame grounding.</p>

Using the Compression Terminal



Note: In addition to the grounding location shown in the following section, the AC chassis option also contains an identical grounding location in the upper right corner of the rear of the chassis. Either location may be used.

To ground the CVX 600 chassis using the compression terminal, follow these steps:

Step	Action
1	Locate a suitable ground cable at your facility.
2	On the back of the chassis, locate the posts with the ground symbol.

(continued)

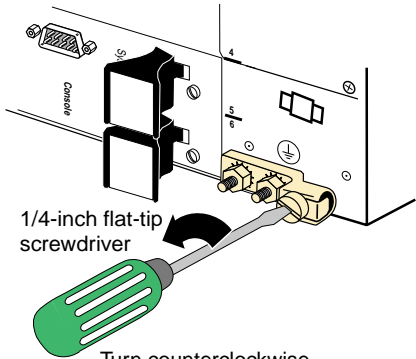
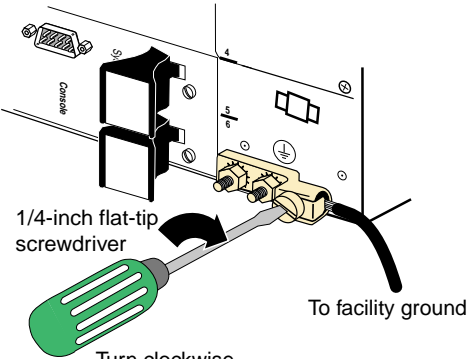
Step	Action
3	<p>Use a flat-tip screwdriver to loosen the locking screw.</p>  <p>1/4-inch flat-tip screwdriver</p> <p>Turn counterclockwise to loosen screw.</p> <p>CVX-0225A</p>
4	<p>Use a wire stripper to remove approximately 1/2 inch of insulation from the ground cable.</p>
5	<p>Insert the stripped end of the wire into the compression terminal; ensure that the wire is inserted between the retainer and the back of the connector. If the screw comes in contact with the wire, remove the wire and insert it below the retainer to ensure a proper ground connection.</p>  <p>1/4-inch flat-tip screwdriver</p> <p>To facility ground</p> <p>Turn clockwise to tighten screw to 24 in-lb.</p> <p>CVX-0246A</p>
6	<p>Use the flat-tip screwdriver to tighten the locking screw to 24 in-lb.</p>
7	<p>Ensure that the other end of the ground cable is properly connected for frame grounding.</p>

Connecting to a Customer-Supplied DC Power Source

The customer-supplied DC power source is only for the DC chassis option.

Prerequisites

Before connecting the CVX 600 to a DC power source, see “[DC Power Supply Warnings](#)” on [page vii](#).



Caution: Ensure that the wire gauge you use is adequate for the distance between the CVX 600 and the DC power source. Before connecting power cables to the CVX 600, use a volt/ohm meter to ensure that the power cables are not live.

Connecting to a DC Power Source

To connect to the power source, follow these steps:

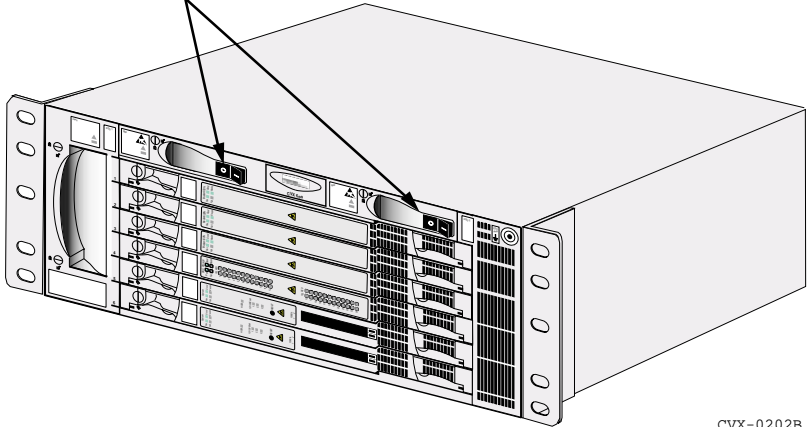
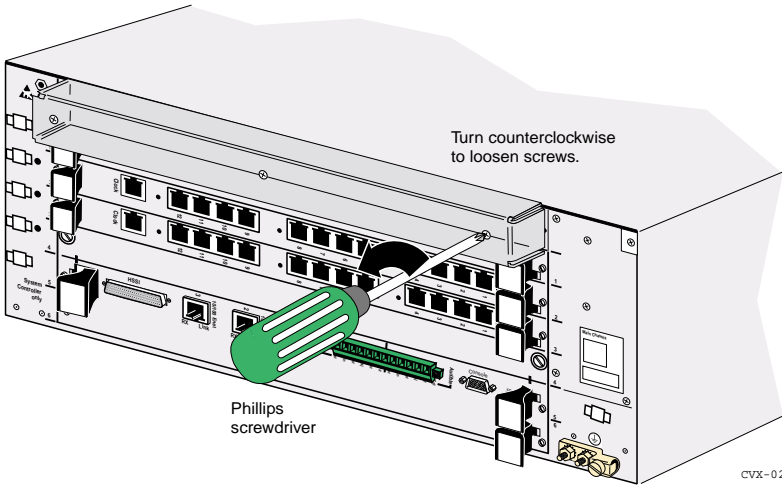
Step	Action
1	<p>Make sure the power switches on the PDUs are off.</p> <p>Circuit breaker (PDU) switches</p>  <p>CVX-0202B</p>
2	<p>Remove the clear cover by removing the three screws on the cover.</p> <p>Turn counterclockwise to loosen screws.</p>  <p>Phillips screwdriver</p> <p>CVX-0203A</p>
3	<p>Remove the nuts from the posts using a 3/8-inch nutdriver.</p>

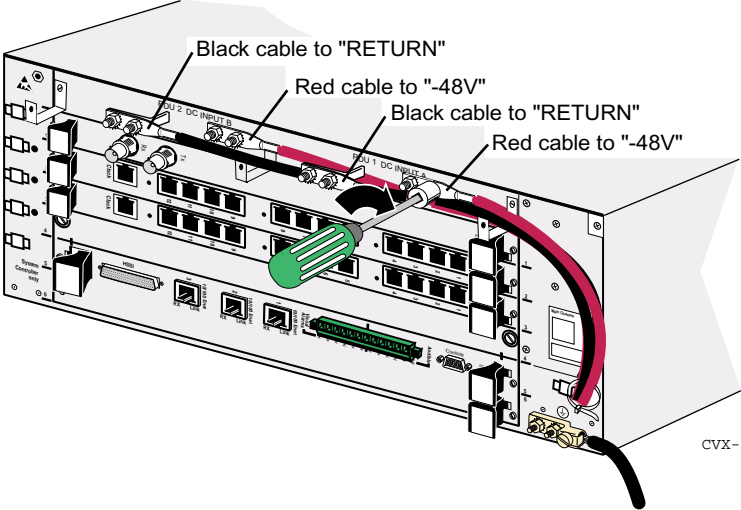
Step	Action
4	<p>Place the lugs of the wires over the posts. Make sure that the lugs for the black wires are on the posts labeled "RETURN" on the raised brackets, and that the lugs for the red wires are on the posts labeled "-48V" on the brackets that are flush with the surface.</p> 
5	Tighten nuts to 13 in-lb using the nutdriver.
6	Secure the cables using a cable tie through the cable mount on the lower right side of the chassis.

(continued)

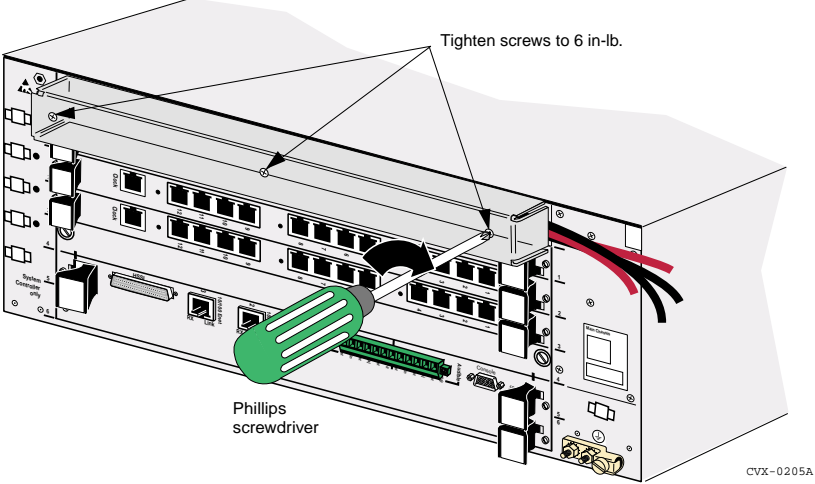
Step	Action
7	<p data-bbox="458 249 1272 309">Install the clear plastic protective cover, securing the cover with three screws. Tighten the screws to 6 in-lb.</p>  <p data-bbox="686 725 772 765">Phillips screwdriver</p> <p data-bbox="1196 791 1265 805">CVX-0205A</p>
8	<p data-bbox="458 840 1248 864">Connect the -48V and RETURN DC power cables to the DC power source.</p>

Next Step

To apply power, see [“Applying Power to the CVX 600”](#) on page 2-42.

Connecting Chassis to an AC Power Source

The AC power source is only for the AC chassis option.

Connecting the Power Cords

To connect the power cords to the chassis, follow these steps:

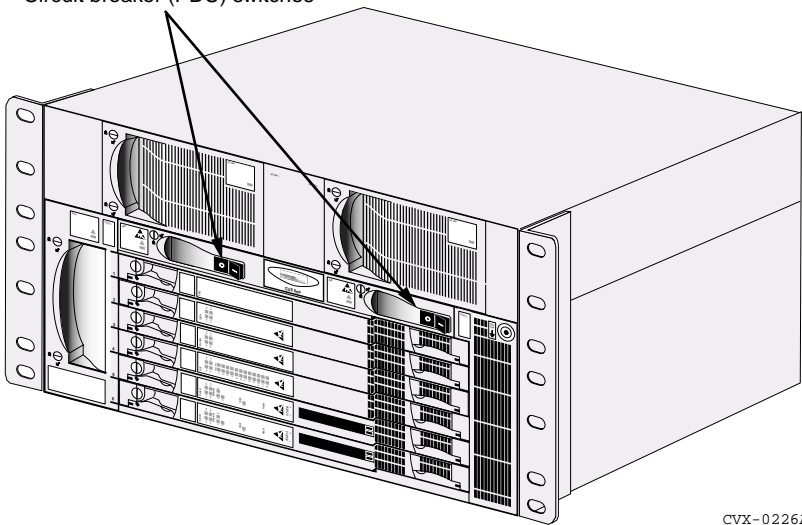
Step	Action
1	<p>Make sure that the two power switches on the circuit breaker modules (PDUs) are off.</p> <p>Circuit breaker (PDU) switches</p>  <p>CVX-0226A</p>

(continued)

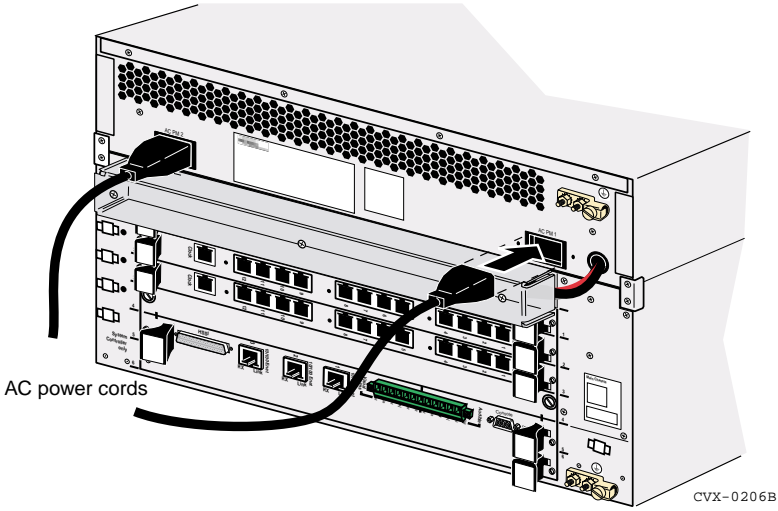
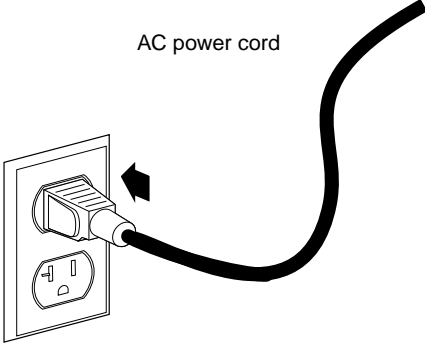
Step	Action
2	<p data-bbox="461 248 1276 274">Insert the power cords into the receptacles labeled “AC PM2” and “AC PM1.”</p>  <p data-bbox="482 673 629 699">AC power cords</p> <p data-bbox="1168 782 1253 800">CVX-0206B</p>
3	<p data-bbox="461 821 1200 847">Insert the other ends of the power cords into the AC power receptacle.</p>  <p data-bbox="786 899 932 925">AC power cord</p> <p data-bbox="632 1234 939 1359">Connect to a grounded 20 A power source (100 to 240 VAC). (North America: 120 V at 20 A) (Europe: 240 V at 10 A)</p> <p data-bbox="1011 1355 1103 1373">CVX-0230A</p>

Next Step

To apply power, see [“Applying Power to the CVX 600”](#) on page 2-42.

Routing the Cables

Cable Mounts

The CVX 600 chassis includes plastic cable mounts that you can use to position the cables, using cable ties (not supplied), around the chassis. These mounts help to ensure that the cables at the back of the chassis do not obstruct airflow and do not obstruct the removal of LTMs and RLTM's.

Suggested Use

Typically, the cable mounts on the left are used to route communications cables, while the one on the lower right is used to route power cables.

Locations of Cable Mounts

The following figure shows the location of the cable mounts.

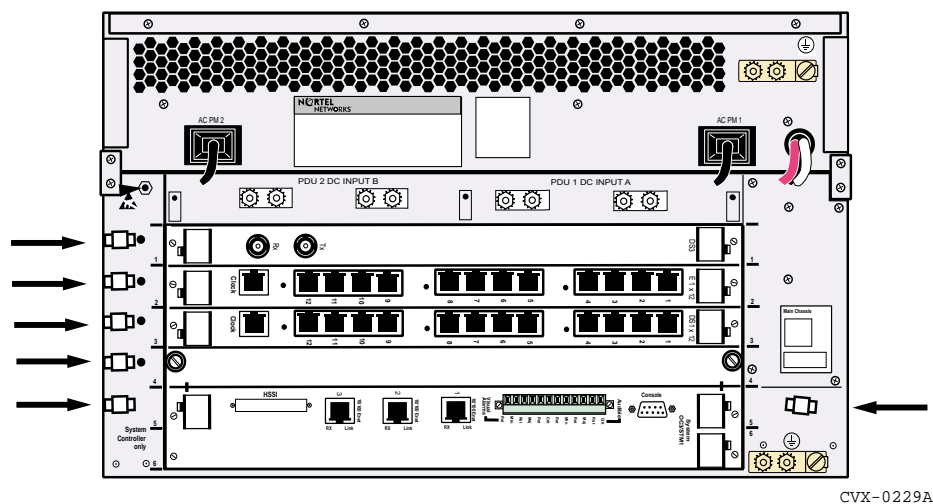

Routing Fiber Optic Cables

Introduction

The routing of fiber optic cables requires different considerations than the routing of wire cables, due to the delicate material of the transmission line.

Minimum Radius

The following table gives the minimum bend radius for several types of fiber optic cable:

Cable/Fiber Type	Number of Fibers	Minimum Bend Radius (normal handling)	Minimum Bend Radius (static load)
Simplex	1	35 mm	50 mm
Duplex	2	70 mm	140 mm
Quad	4	85 mm	160 mm



Note: The minimum radius must be maintained at all times, including while routing the cable and managing slack cable.

Rack Standoff Brackets

To ensure that the fiber optic cable is properly secured to the chassis, a rack-mounted bracket may be used to support the fiber optic cable. Nortel does not supply a bracket for this purpose.

Securing and Wrapping Fiber Optic Cables

Fiber optic cables can be secured with tie wraps, if not applied too tightly. Your application may also require the fiber to be wrapped in a protective paper. Tie wraps must be fitted in accordance with Nortel Work Standards WS-001 and WS-4024.

Installing and Removing the Flash Memory Cards

Description

The SCC-SM contains dual PCMCIA slots for the flash memory card. The flash memory card provides storage for the CVX 600 nonvolatile file system (NVFS), operating system software, and configuration files. When you insert the flash memory card, the NVFS automatically provides access to the flash memory card.

The dual PCMCIA slots are labeled 1 and 2. Slot 1 is the C: drive and slot 2 is the D: drive. Always use slot 1 for the flash memory card. Use slot 2 if you need to copy the flash memory card in slot 1 to a flash memory card in slot 2.

Reference

See the manual *CVX Multi-Service Access Switch Configuration Guide* for information about copying a flash memory card.



Note: If the flash memory card is not already in the SCC, insert it into slot 1.



Warning: You must use software Release 5.0 or later when using an Optical SCC-II-SM. Use of older versions will corrupt the SCC-SM, requiring the return of the module to Nortel for reprogramming. Do not copy earlier versions of software to a flash memory card used in an Optical SCC-II-SM.

Inserting a Flash Memory Card

To insert a flash memory card, follow these steps:

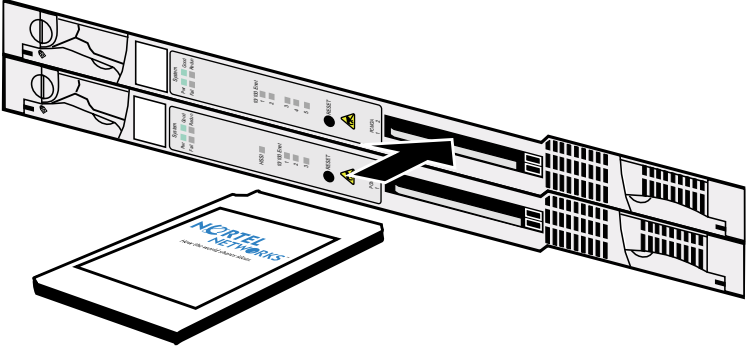
Step	Action
1	Position the card so that its label is facing up.
2	Insert the card into slot 1 and gently push the card until it clicks into position. 

CVX-0231A

Removing a Flash Memory Card

To remove a flash memory card, follow these steps:

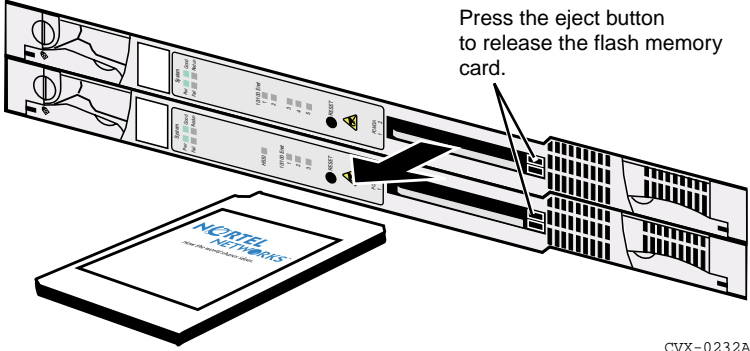
Step	Action
1	<p>Press the eject button next to the slot (labeled 1 or 2) from which you want to remove a flash memory card.</p>  <p>Press the eject button to release the flash memory card.</p> <p>CVX-0232A</p>
2	Pull the flash memory card out of the slot.

Connecting Equipment to the Console Port

Introduction

You can connect a terminal, PC, modem, or terminal server to the CVX 600, using the console port on the SCC.

The following procedures provide steps for connecting each piece of equipment:

- [“Connecting a Terminal”](#)
- [“Connecting a PC”](#)
- [“Connecting a Modem”](#)
- [“Connecting a Terminal Server”](#)



Note: Once you have connected this equipment, you can then edit your system configuration.

Connecting a Terminal

To connect a terminal to the CVX 1800 using the DB-9 to DB-9 cable, follow these steps:

Step	Action																
1	<p>Turn on the terminal, then configure it using the parameters listed below.</p> <p>Reference: For instructions, see the documentation for the terminal or the terminal emulation program.</p> <table border="1" style="width: 100%; border-collapse: collapse;"> <thead> <tr> <th style="text-align: left;">Parameter</th> <th style="text-align: left;">Value</th> </tr> </thead> <tbody> <tr> <td>Terminal type</td> <td>VT-100</td> </tr> <tr> <td>Baud rate</td> <td>19200</td> </tr> <tr> <td>Connect using</td> <td>Direct to COM 1</td> </tr> <tr> <td>Flow control</td> <td>None</td> </tr> <tr> <td>Data bits</td> <td>8</td> </tr> <tr> <td>Stop bits</td> <td>1</td> </tr> <tr> <td>Parity</td> <td>None</td> </tr> </tbody> </table>	Parameter	Value	Terminal type	VT-100	Baud rate	19200	Connect using	Direct to COM 1	Flow control	None	Data bits	8	Stop bits	1	Parity	None
Parameter	Value																
Terminal type	VT-100																
Baud rate	19200																
Connect using	Direct to COM 1																
Flow control	None																
Data bits	8																
Stop bits	1																
Parity	None																
2	Turn off the terminal.																

(continued)

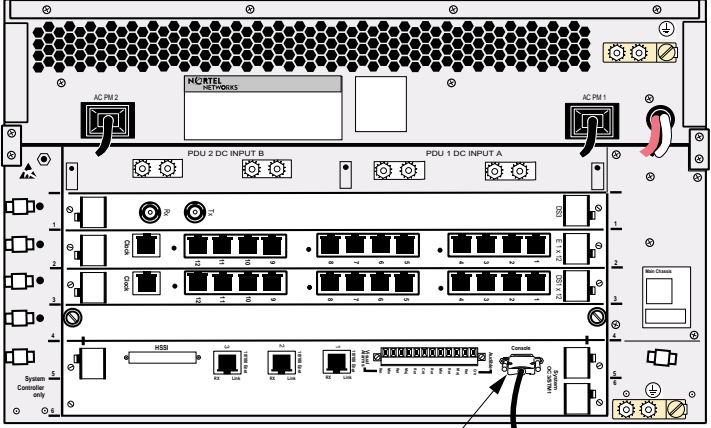
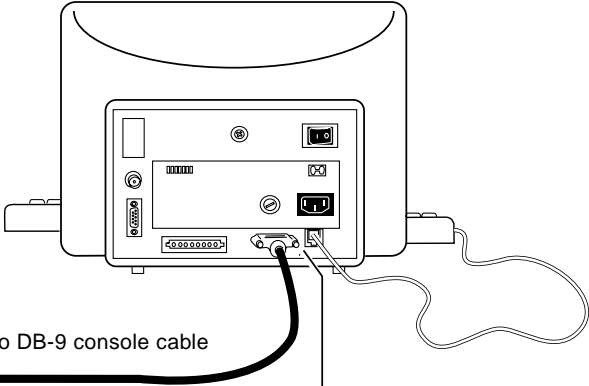
Step	Action
3	<p>Attach the 9-pin receptacle end of the console cable to the console port.</p>  <p>Console port DB-9 to DB-9 console cable</p> <p>CVX-0207A</p>
4	<p>Attach the 9-pin plug end of the console cable to the DB-9 port on the back of the terminal.</p>  <p>DB-9 to DB-9 console cable</p> <p>DB-9 port on terminal</p> <p>CVX-0227A</p>

Connecting a PC

To connect a PC to the CVX 600 using the DB-9 to DB-9 cable, follow these steps:

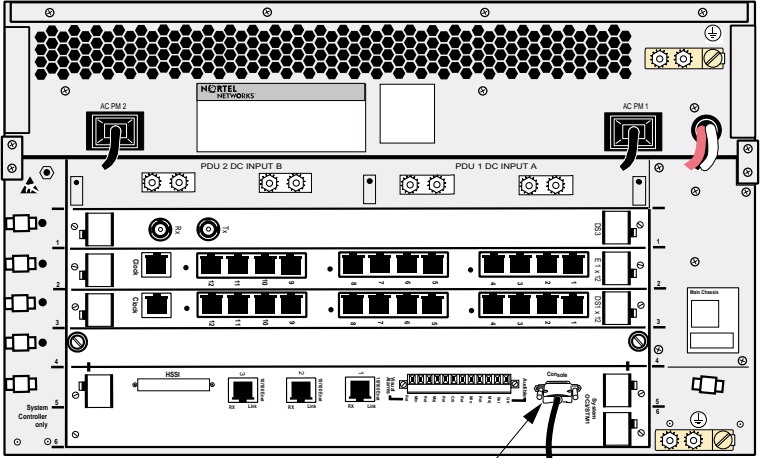
Step	Action
1	<p>Attach the 9-pin receptacle end of the console cable to the Console port.</p>  <p>CVX-0207A</p>

(continued)

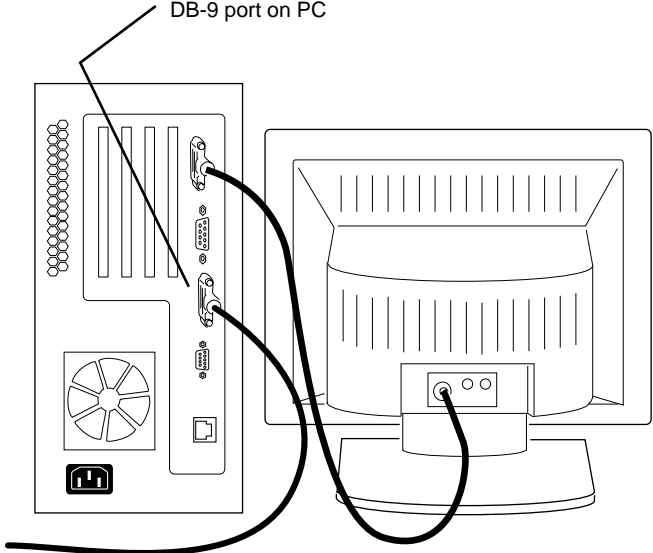
Step	Action
2	<p data-bbox="458 249 1273 309">Connect the 9-pin plug end of the console cable to the DB-9 port on the back of the PC.</p>  <p data-bbox="701 321 858 343">DB-9 port on PC</p> <p data-bbox="535 894 811 916">DB-9 to DB-9 console cable</p> <p data-bbox="1100 894 1186 911">CVX-0120B</p> <p>The diagram illustrates the connection of a console cable. On the left, the back panel of a PC is shown with various ports. A line points to a specific DB-9 port, labeled 'DB-9 port on PC'. A cable is plugged into this port. On the right, the back of a monitor is shown with a DB-9 port. The other end of the cable is plugged into this port. The cable is labeled 'DB-9 to DB-9 console cable'. The reference code 'CVX-0120B' is located in the bottom right corner of the diagram area.</p>

Connecting a Modem

If you need remote dial-in access to the command line interface (CLI), you can connect a modem (AT or Hayes compatible) to the CVX 600 using the DB-9 to DB-25 modem cable.

To connect a modem to the CVX 600, follow these steps:

Step	Action	
1	Turn on the modem, then configure it using the parameters listed below.	
	For instructions, see the documentation for the modem.	
	Modem Parameter	Value/State
	Baud rate	56 Kb/s (or less)
	Auto answer	Set to <i>n</i> rings with DTR active. (The value <i>n</i> must be greater than 0. If the value is 0, Auto answer is disabled.)
	Clear to send (CTS) signal	Always on
	Data terminal ready (DTR) signal	DTR signal fail-disconnect enabled. Return to command mode; Auto answer is disabled.
	Data carrier detect (DCD) signal	DCD signal on while carrier present. (The CVX 1800 uses the DCD signal to detect a modem disconnect.)
	Local character echo	Off
	Supervisory functions	Off
	Data set ready (DSR) signal	On
2	Turn off the modem.	
3	Remove the console cable from the console port.	

(continued)

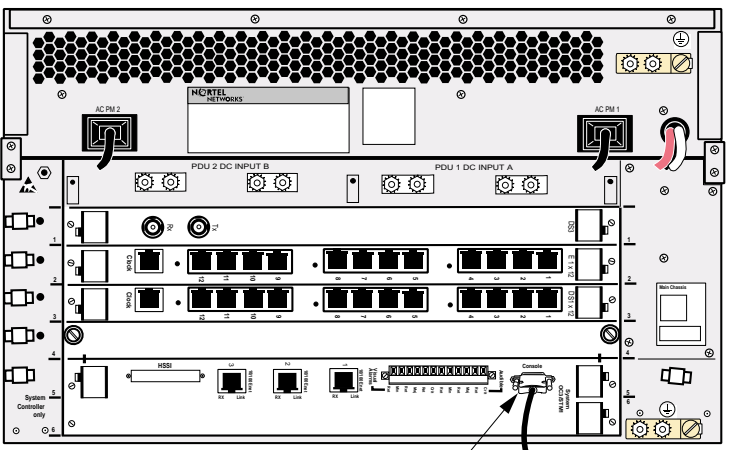
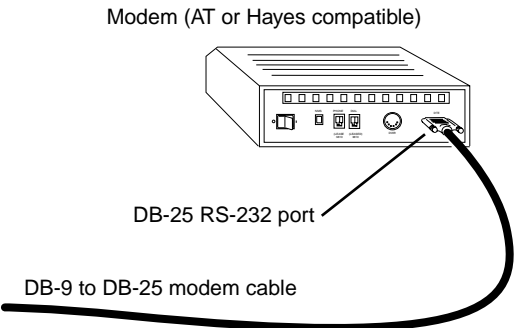
Step	Action
4	<p>Attach the 9-pin receptacle end of the modem cable to the console port.</p>  <p>The diagram shows the rear panel of a CVX-0208A device. It features various ports including AC PM 1 and AC PM 2, PDU 1 DC INPUT A, PDU 2 DC INPUT B, and several network ports. A DB-9 to DB-25 console cable is shown connected to the console port, which is a 9-pin D-sub connector. The cable is labeled 'DB-9 to DB-25 console cable'.</p> <p style="text-align: right;">CVX-0208A</p>
5	<p>Attach the 25-pin plug end of the modem cable to the modem's DB-25 RS-232 data communications port.</p>  <p>The diagram shows a modem (AT or Hayes compatible) with a DB-9 to DB-25 modem cable connected to its DB-25 RS-232 port. The cable is labeled 'DB-9 to DB-25 modem cable'.</p> <p style="text-align: right;">CVX-0121A</p>



Note: If you need remote dial-in access to the command line interface (CLI), you can connect a modem (AT or Hayes compatible) to the CVX 1800 using the DB-9 to DB-25 modem cable, or through a terminal server.

Connecting a Terminal Server

A terminal server provides remote access to multiple CVX switches through serial ports connected to the console port of the SCC-RLTMs. A terminal server also allows the addressing of both SCCs when a CVX switch is using two Optical SCC-II-LTMs, each with its own console port.

Sample Hardware Arrangement for CVX Switches

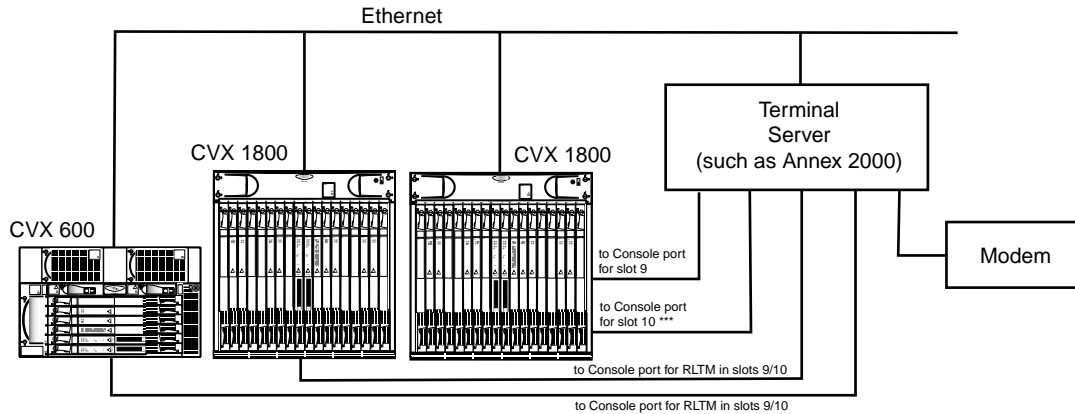

*** The connection to the console port for slot 10 is only needed if connecting to the Optical SCC-II-LTM.

CVX-0141C

Rear Connections for Sample Hardware Arrangement

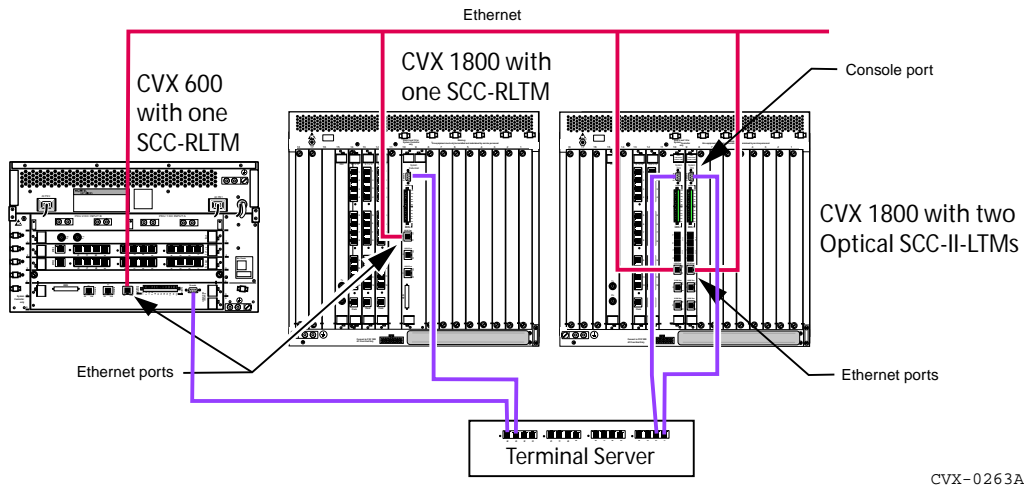

Note: When using the Optical SCC-II-LTMs in slots 9 and 10 in the CVX 1800, or slots 5 and 6 in the CVX 600, the active SCC will need to be addressed.

Recommendations

Terminal server use is also recommended in the following cases:

- Where the CVX chassis is in a remote location
- When Ethernet access is restricted
- To provide a backup method for access when Ethernet or Telnet access is disrupted

Connecting Equipment to a Local Ethernet Port

Description

The 10/100 Mb/s Ethernet port on the SCC-LTM and SCC-RLTM allows you to connect a remote PC or similar device to the CVX 600 using an Ethernet hub. Connecting to a remote PC allows you to edit a CVX 600 configuration using Telnet. You can also use the Ethernet port to connect to a remote Simple Network Management Protocol (SNMP) server for SNMP-based management.



Note: The 10/100 Mb/s Ethernet port is an autosensing port that adjusts automatically for 10 or 100 Mb/s transmission. This means that the port selects the correct operating speed based on the data packets it receives from the remote PC.

Connecting a Remote Device Using an Ethernet Port

The following figure shows connecting a remote PC to the Ethernet port.

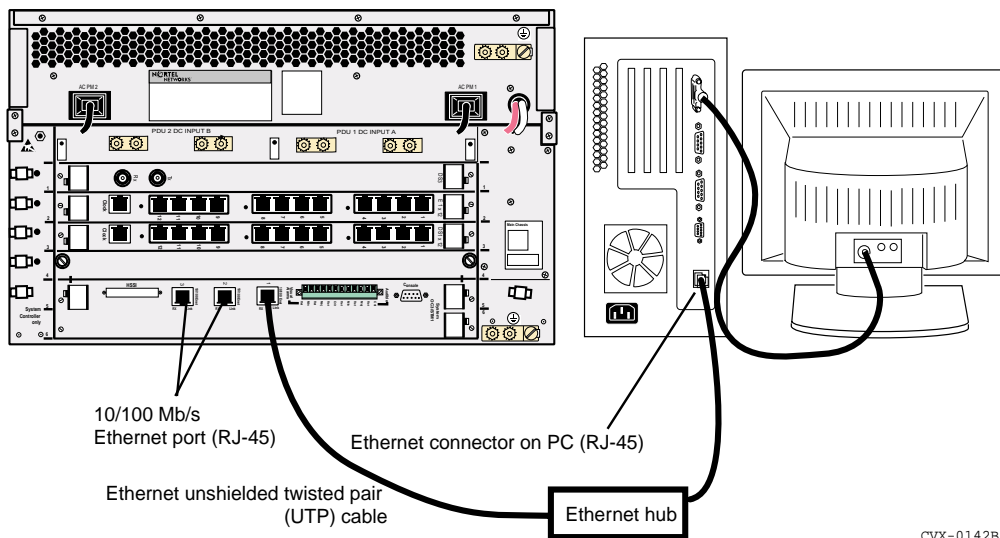

Applying Power to the CVX 600

Procedure

To apply power to the CVX 600, follow these steps:

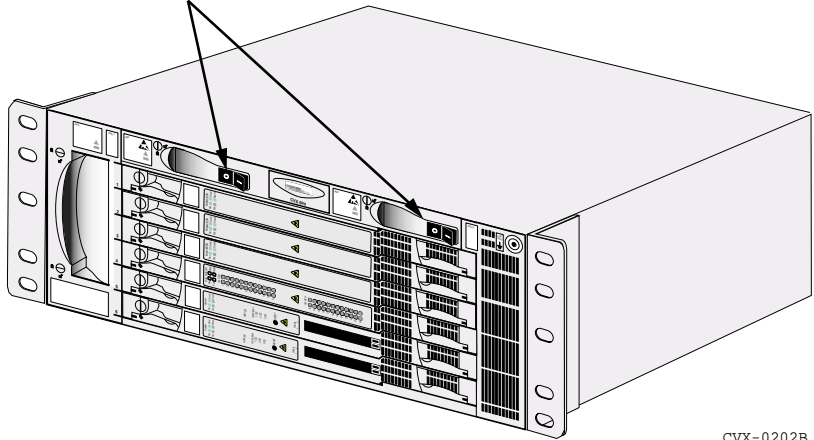
Step	Action
1	Ensure that you have connected all power cables to the appropriate terminals.
2	Ensure that you have installed the clear protective cover over the power cable terminals.
3	Ensure that you have inserted the flash memory card in PCMCIA slot 1 on the SCC (the upper SCC, if using master and redundant SCCs).
4	Ensure that both switches on the circuit breakers (PDUs) are off. Circuit breaker (PDU) switches  CVX-0202B
5	Apply power from the power source.
6	Ensure that the red LEDs on both PDUs are on. If they are, turn the switches on both circuit breakers (PDUs) on. If the LEDs are not on, check all power connections.

Checking the LEDs

Introduction

The LEDs provide important information about the operating status of the system control and access cards. These include the following cards:

- [SCC-SM, SCC-RLTM \(Ethernet 10/100 Mb/s ports\)](#)
- [SCC-HSSI-SM, SCC-HSSI-RLTM](#)
- [Optical SCC-II](#)
- [Optical DAC](#)
- [DAC-SM LEDs](#)
- [MAC-SM LEDs](#)

SCC-SM, SCC-RLTM (Ethernet 10/100 Mb/s ports)

The following figure shows the LEDs on the SCC-SM and SCC-RLTM.



Note: The number of Ethernet connectors and Ethernet LEDs may vary from what is shown, depending on the model of LTM you have. However, the LED information is the same.

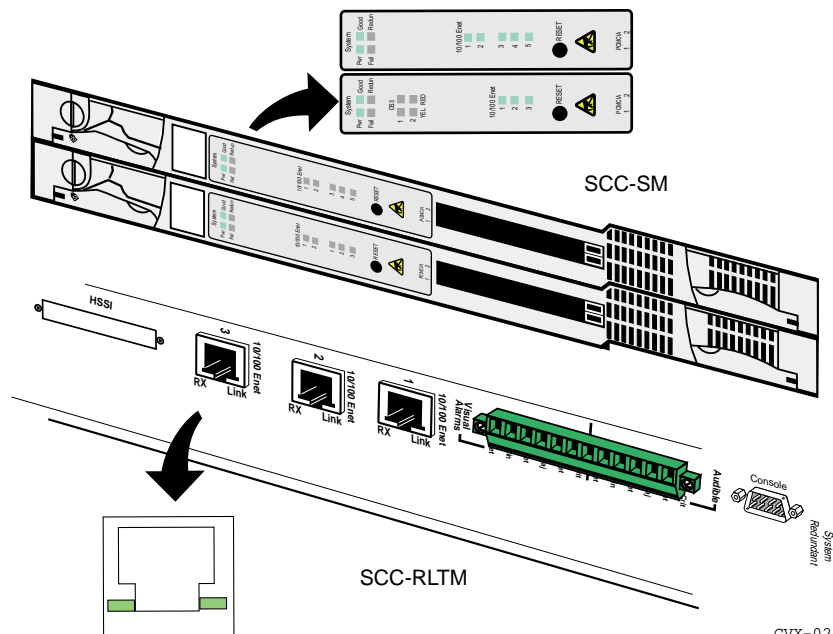

CVX-0209C

LEDs on the SCC-SM

The following table describes the LEDs on the SCC-SM:

LED	State	Meaning
Pwr	Off On (green)	Power off Power on
Good	On (green) Off Flashing green	Successful system boot: no errors detected No power: failure detected or on standby Code loading during system boot
Fail	Off On (red)	No power Failure detected
Redun	Off On (green)	No power or no redundancy A working redundant configuration
10/100 Enet 1, 2, 3	Off On (green) On (red)	No link present Online: normal operating condition Alarm condition

LEDs on the SCC-RLTM

The following table describes the LEDs on the SCC-RLTM:

LED	State	Meaning
Link	Off On (green)	No link present Link present
Rx	Off Flashing green	Not receiving data Receiving data

SCC-HSSI-SM, SCC-HSSI-RLTM

The following figure shows the LEDs on the SCC-HSSI-SM and SCC-HSSI-RLTM:

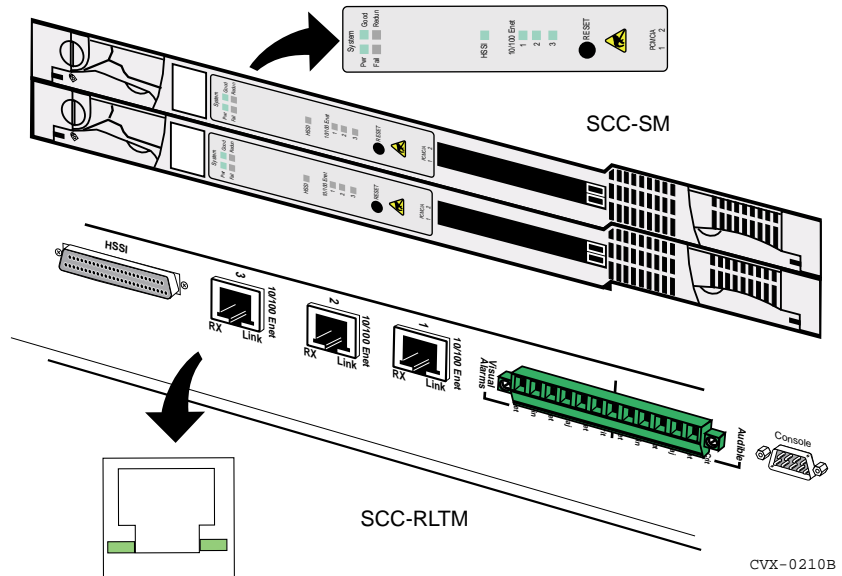

LEDs on the SCC-HSSI-SM

The following table describes the LEDs on the SCC-HSSI-SM:

LED	State	Meaning
Pwr	Off On (green)	Power off Power on
Good	On (green) Off Flashing green	Successful system boot: no errors detected No power: failure detected or on standby Code loading during system boot
Fail	Off On (red)	No power Failure detected
Redun	Off On (green)	No power or no redundancy A working redundant configuration
10/100 Enet 1, 2, 3	Off On (green) On (red)	No link present Online: normal operating condition Alarm condition
HSSI	On (green) Off	Online: normal operating condition No link present

LEDs on the SCC-HSSI-RLTM

The following table describes the LEDs on the SCC-HSSI-RLTM:

LED	State	Meaning
Link	Off On (green)	No link present Link present
Rx	Off Flashing green	Not receiving data Receiving data

LEDs on the Optical SCC-II-SM

The following table describes the LEDs on the Optical SCC-II-SM:

LED	State	Meaning
Power	Off	Power off
	On (green)	Power on
Good	On (green)	Successful system boot: no errors detected
	Off	No power: failure detected or on standby
	Flashing green	Code loading during system boot
Failed	Off	No power
	On (red)	Failure detected
Redun	Off	No power or no redundancy
	On (green)	A working redundant configuration
Sonet	On (green)	Normal operating condition
	On (red)	Sonet/SDH alarm condition
ATM	Off	Not initialized
	On (red)	Initialized, but not operational
	On (green)	Operational
Prot	Off	Automatic protection switching is either not configured, or if configured, the protected link is inactive
	On (amber)	Protected link is active
Prim	Off	Automatic protection switching is not configured, or if configured, primary link is inactive
	On (green)	Primary link is active
ATM1	Off	Physical link connection not detected
	On (green)	Physical link connection detected
ATM2	Off	Physical link connection not detected
	On (green)	Physical link connection detected
10/100 Enet 1, 2, 3	Off	No link present
	On (green)	Online: normal operating condition
	On (red)	Alarm condition

LEDs on the Optical SCC-II-LTM

The following table describes the LEDs on the Optical SCC-II-LTM:

LED	State	Meaning
Link	Off	No link present
	On (green)	Link present
Rx	Off	Not receiving data
	Flashing green	Receiving data

Optical DAC

The following figure shows the LEDs on the Optical DAC-SM:



CVX-0144B

LEDs on the Optical DAC-SM

The following table describes the LEDs on the Optical DAC-SM:

LED	State	Meaning
Power	Off	Power off
	On (green)	Power on
Good	On (green)	Successful system boot: no errors detected
	Off	No power: failure detected or on standby
	Flashing green	Code loading during system boot
Fail	Off	No power
	On (red)	Failure detected
Redun	Off	No power or no redundancy
	On (green)	A working redundant configuration
LOF	Off	Normal
	On (orange)	The SONET/SDH framing bytes for A1 or A2 are wrong or corrupted.
LOS	Off	Normal
	On (orange)	The designated port has a loss of carrier condition, due to a faulty connection with an SC connector on the receive side or a physical break in the fiber.



Note: There are no LEDs on the Optical DAC-LTMs.

DAC-SM LEDs

The following figure shows the LEDs on the DS1-DAC-SMs, E1-DAC-SMs, and DS3-DAC-SMs:

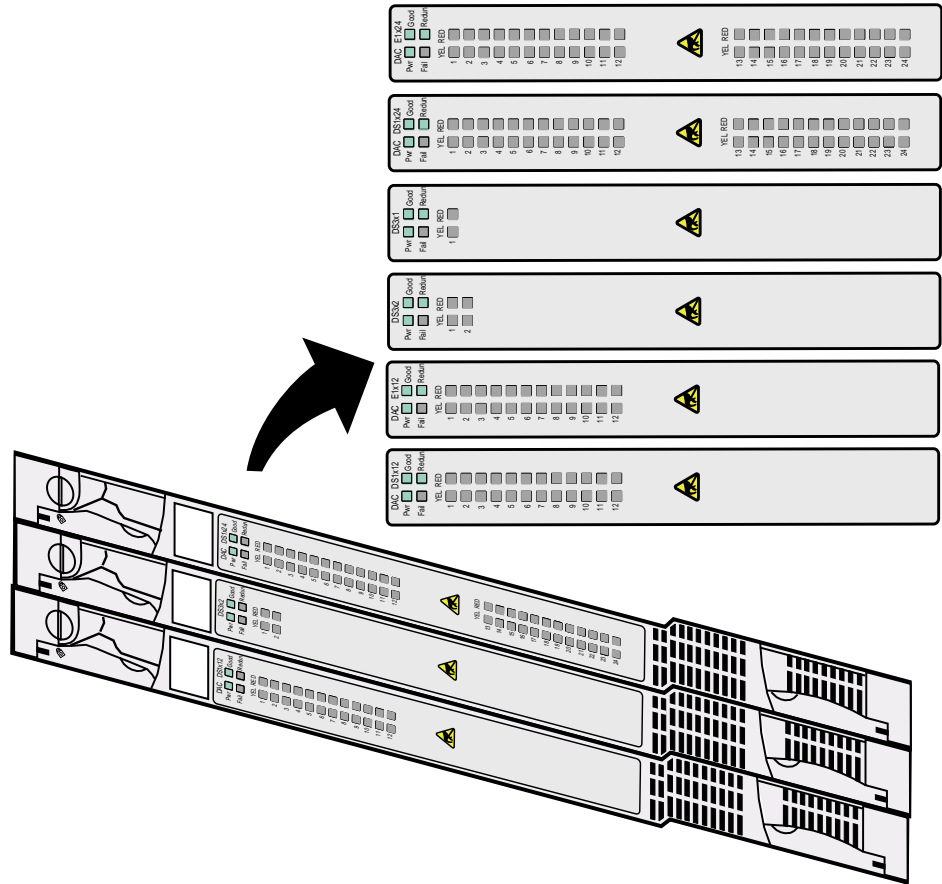

CVX-0247B

LEDs on DAC-SM

The following table describes the LEDs on the DS1-DAC-SM, E1-DAC-SM, and DS3-DAC-SM:

LED	State	Meaning
Pwr	Off On (green)	Power off Power on
Good	On (green) Off	Successful system boot: no errors detected No power: failure detected or on standby
Fail	Off On (red)	No power Failure detected
Redun	Off On (green)	No power or redundancy A working redundant configuration
YEL (1, 1 to 2, 1 to 12 or 1 to 24)	On (yellow) Off	Yellow alarm: remote switch is not receiving a signal from the CVX 600 No alarm
RED (1, 1 to 2, 1 to 12, or 1 to 24)	On (red) Off	Red alarm: remote switch is not receiving a signal from the remote switch No alarm

MAC-SM LEDs

The following figure shows the LEDs on the MAC-SM:

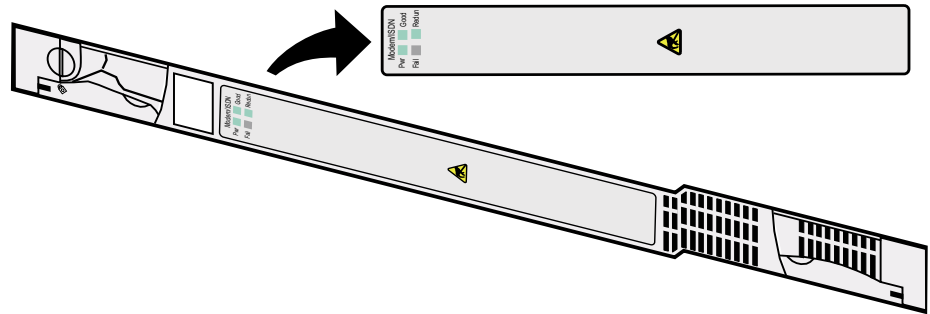

CVX-0248A

LEDs on the MAC-SM

The following table describes the LEDs on the MAC-SM:

LED	State	Meaning
Pwr	Off On (green)	Power off Power on
Good	On (green) Off	Successful system boot: no errors detected No power: failure detected or on standby
Fail	Off On (red)	No power Failure detected
Redun	Off On (green)	No power or no redundancy A working redundant configuration

Reference

For information about creating and editing the system configuration at boot time, see the manual *CVX Multi-Service Access Switch Startup Guide*.

Chapter 3

Replacing CVX 600 Components

About This Chapter

Introduction

This chapter describes how to replace and CVX 600 hardware components.

Topics

This chapter covers the following topics:

Topic	Page
Attaching the Antistatic Wrist Strap	3-2
Replacing Modules and Filler Panels	3-4
Removing and Installing Filler Panels	3-4
Replacing the SCC-SM	3-11
Replacing the SCC-LTM/RLTM	3-16
Replacing Other Service Modules	3-21
Replacing the DAC-LTM/-RLTM	3-26
Replacing the Fan Module	3-31
Replacing a PDU Module	3-36
Replacing a Power Module	3-40
Ordering Replacement Components	3-44

Attaching the Antistatic Wrist Strap

Location of Wrist Strap

The antistatic wrist strap is located in the accessory kit.

Purpose of Wrist Strap

The antistatic wrist strap directs the discharge of static electricity from your body to the chassis, thereby protecting sensitive electronic components.



Caution: Electrostatic discharge can damage hardware. Follow the procedure in this section to protect your equipment from damage.

How to Attach the Wrist Strap

Follow these steps:

Step	Action
1	Remove the strap and cable from the accessory kit.
2	Attach the snap end of the cable to the wrist strap.

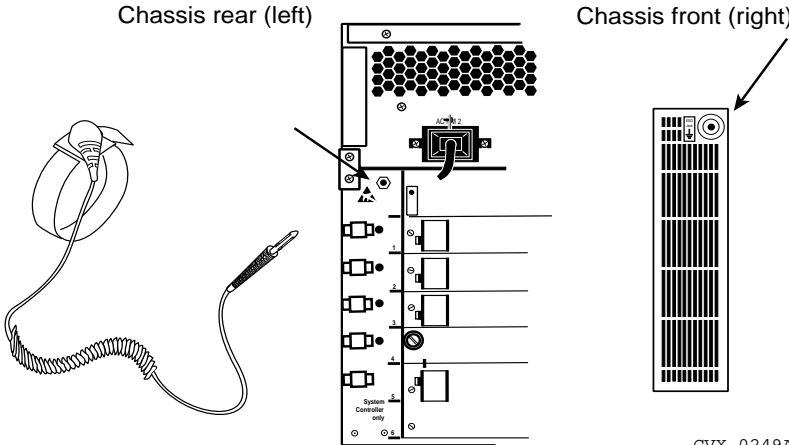
Step	Action
3	Place the strap around your wrist, then adjust it to ensure that the metal buckle inside the strap touches your skin.
4	<p>Plug the jack at the other end of the cable into the front or rear of the chassis, depending on which side of the chassis you are working.</p>  <p>Chassis rear (left) Chassis front (right)</p> <p>CVX-0249A</p>

Replacing Modules and Filler Panels

Introduction

This section provides instructions for replacing chassis components and hardware modules. It describes how to:

- Remove and install filler panels
- Replace the SCC-SM
- Replace the SCC-LTM or SCC-RLTM
- Replace other service modules (SMs)
- Replace DAC-LTMs and DAC-RLTMs



Note: You *must* wear an antistatic wrist strap when you remove or install these components and modules.

Removing and Installing Filler Panels

You must install filler panels in any empty slots at the front or rear of the CVX 600 chassis. Filler panels ensure proper air circulation in the chassis, as well as assist in emissions compliance. If you need to install a card in an empty slot, you must first remove the filler panel.

Removing a Rear Filler Panel

To remove a rear filler panel, follow these steps:

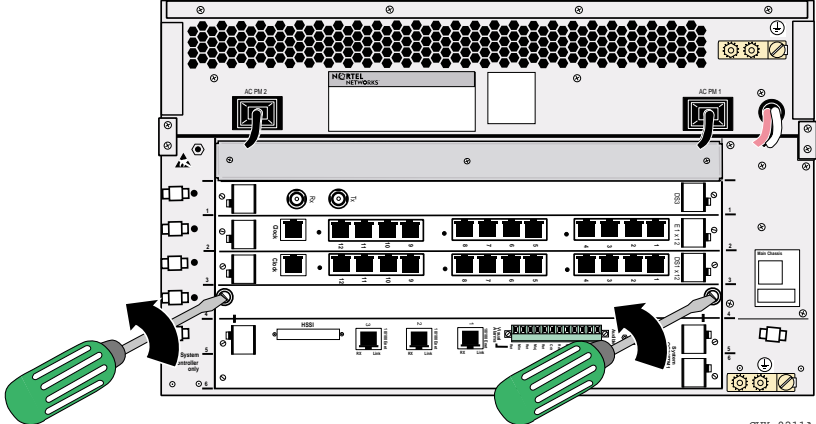
Step	Action
1	<p>Use a 1/4-inch flat-tip screwdriver to loosen the screws on the left and right sides of the panel.</p>  <p style="text-align: right; font-size: small;">CVX-0211A</p>
2	Remove the filler panel.

Installing a Rear Filler Panel



Note: SCC fillers must be used for slot 5 or 6, adjacent to a single SCC-LTM. All other slots use a MAC/DAC filler. The fillers look identical except for the location of the screws. The installation and removal procedures are the same for both types of fillers.

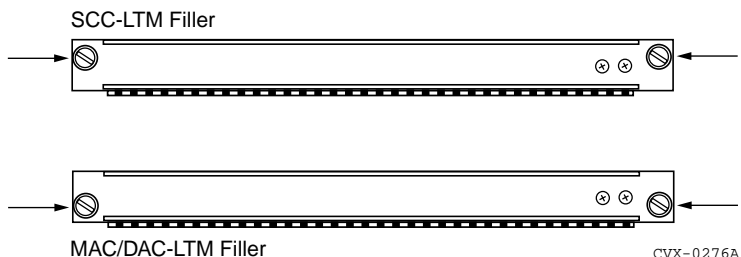

To install a rear filler panel, follow these steps:

Step	Action
1	Insert the filler panel into the empty slot.
2	Use a 1/4-inch flat-tip screwdriver to tighten the screws to 5 in-lb by turning them clockwise.

Tighten to 5 in-lb. Tighten to 5 in-lb.

CVX-0212A

Removing a Front Filler Panel

To remove a front filler panel, follow these steps:

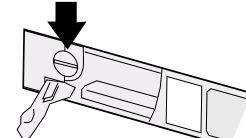
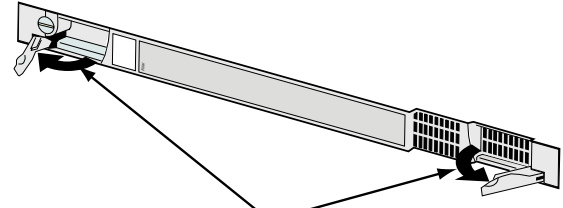
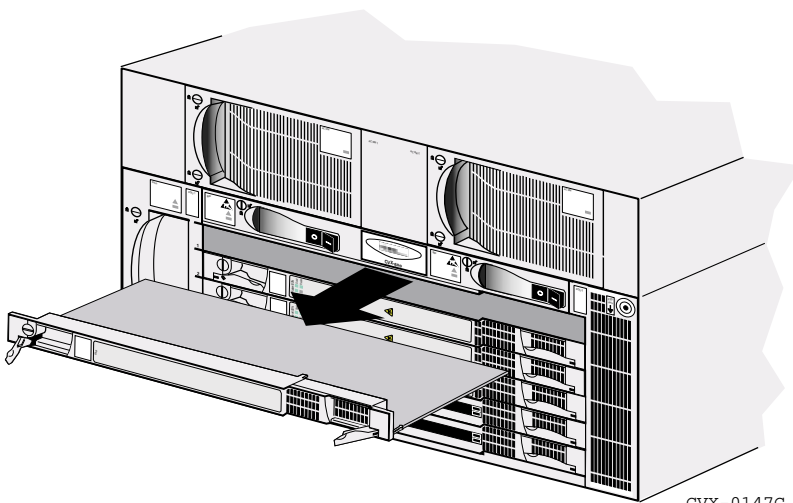
Step	Action
1	<p>Using a flat-tip screwdriver, turn the screw at the upper left corner of the filler panel 1/4 turn counterclockwise.</p> <p style="text-align: center;">Unlocked position</p>  <p style="text-align: right;">CVX-0145A</p>
2	<p>Grasp the left and right ejector levers and pull them outward to eject the panel.</p>  <p style="text-align: center;">Open ejectors</p> <p style="text-align: right;">CVX-0146C</p>
3	<p>Grasp the ejector levers and carefully slide the panel out of the chassis.</p>  <p style="text-align: right;">CVX-0147C</p>

Installing a Front Filler Panel



Note: Filler panels for slots 1 to 4 are marked, “Filler,” and filler panels for slots 5 and 6 are marked, “System Filler.”

To install a front filler panel, follow these steps:

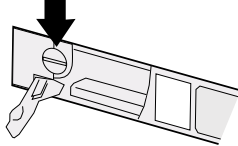
Step	Action
1	<p data-bbox="458 539 1258 565">Make sure that the locking screw is in the unlock position (slot is horizontal).</p> <div data-bbox="739 586 996 781"><p data-bbox="739 586 908 609">Unlocked position</p><p data-bbox="911 762 996 781">CVX-0145A</p></div>

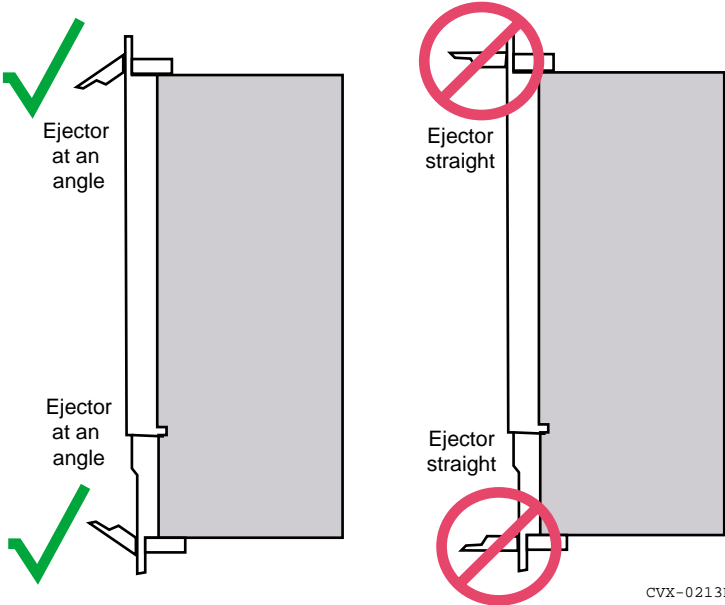
Step	Action
2	<p data-bbox="458 251 1215 279">Ensure that the ejectors are extended at an angle, but not all of the way.</p> <div data-bbox="504 326 1222 933"><p data-bbox="544 447 615 522">Ejector at an angle</p><p data-bbox="544 725 615 800">Ejector at an angle</p><p data-bbox="925 465 996 505">Ejector straight</p><p data-bbox="925 760 996 800">Ejector straight</p><p data-bbox="1143 913 1229 930">CVX-0213B</p></div> <p data-bbox="458 982 1250 1043">Caution: Extending the ejectors all of the way may result in ejector breakage when attempting to close them in step 4.</p>

(continued)

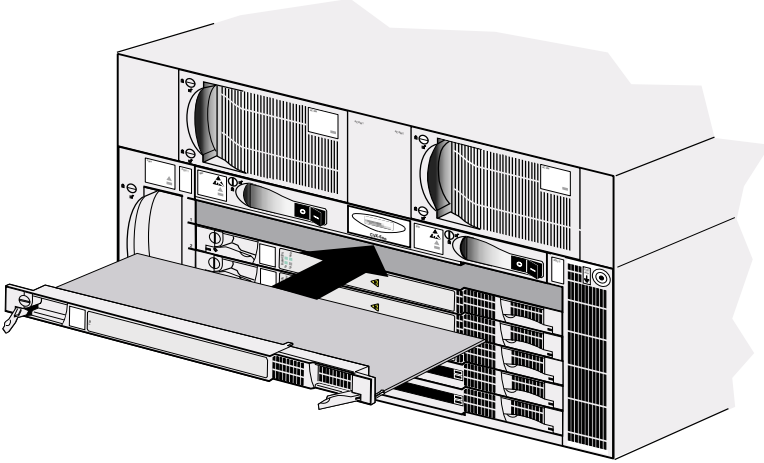
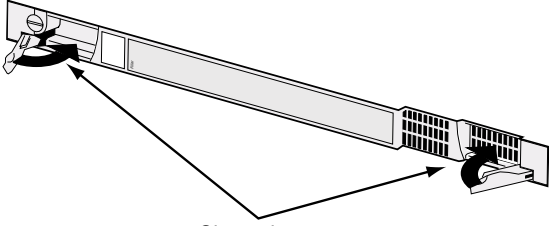
Step	Action
3	<p data-bbox="458 249 1270 309">Ensure that the latch pawl is in the card guide channel and slide the panel into the chassis until its connector touches the chassis mid-plane.</p>  <p data-bbox="1143 795 1239 812">CVX-0148C</p>
4	<p data-bbox="458 840 1222 899">Gently push the ejector levers inward. The right lever will click when fully pushed in.</p>  <p data-bbox="789 1142 925 1159">Close ejectors</p> <p data-bbox="1053 1142 1139 1159">CVX-0149B</p>
5	<p data-bbox="458 1192 1182 1216">Using a flat-tip screwdriver, turn the locking screw 1/4 turn clockwise.</p>

Replacing the SCC-SM

In a redundant configuration, when you replace the primary SCC-SM, the secondary SCC-SM automatically copies the system software and configuration files from its flash memory card. Before replacing the primary SCC-SM, ensure that the secondary SCC-SM flash memory cards are in the PCMCIA slots.

If you have *only one* SCC-SM (a non-redundant configuration), you will need to shut down the CVX switch to replace the SCC-SM.



Warning: You must use software Release 5.0 or later when using an Optical SCC-II-SM. Use of older versions will corrupt the SCC-SM, requiring the return of the module to Nortel for reprogramming. Do not copy earlier versions of software to a flash memory card used in an Optical SCC-II-SM.



Warning: When you remove the primary SCC-SM, a system reset occurs. This disconnects all calls that are in progress and temporarily suspends system services until the secondary SCC-SM goes online.

Reference

See the manual *CVX Multi-Service Access Switch Configuration Guide* for information about editing and managing configuration files.

Removing the SCC-SM

To remove the SCC-SM, follow these steps:

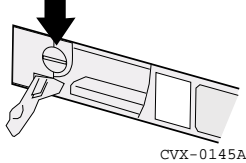
Step	Action
1	Remove the flash memory card from the PCMCIA slot by pressing the eject button located next to the slot.
2	<p>Using a flat-tip screwdriver, turn the locking screw at the upper left corner of the module 1/4 turn counterclockwise (until slot is horizontal).</p> <p style="text-align: center;">Unlocked position</p>  <p style="text-align: right;">CVX-0145A</p>

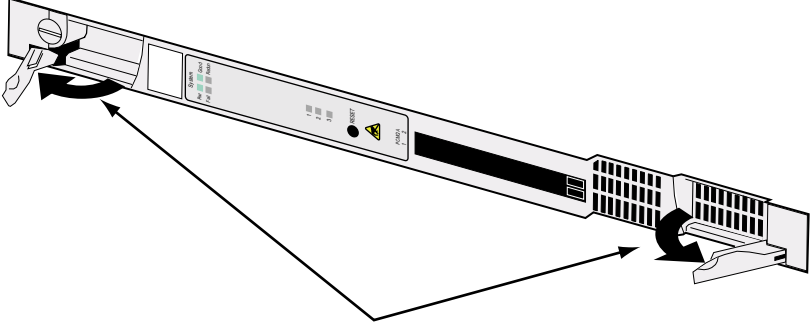
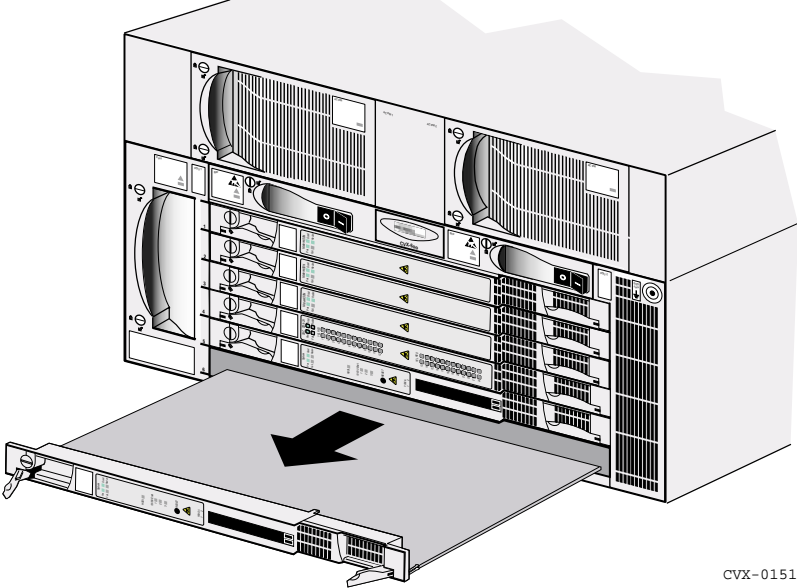
Step	Action
3	<p data-bbox="458 251 1243 338">Grasp the left and right ejector levers and pull them outward to eject the SCC-SM. You will feel the SCC-SM disconnect from the chassis mid-plane and the SCC-LTM or SCC-RLTM.</p>  <p data-bbox="772 696 905 716">Open ejectors</p> <p data-bbox="1179 716 1268 730">CVX-0150C</p>
4	<p data-bbox="458 760 1243 786">Grasp the ejector levers and carefully slide the SCC-SM out of the chassis.</p>  <p data-bbox="1179 1376 1268 1390">CVX-0151B</p>

Installing an SCC-SM

To install an SCC-SM, follow these steps:

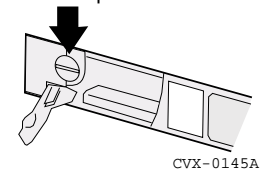
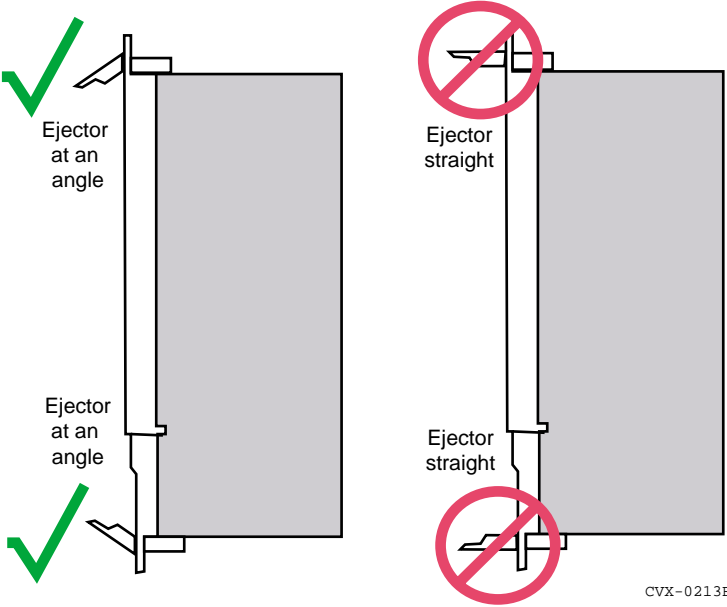
Step	Action
1	<p>Make sure that the locking screw is in the unlocked position (slot is horizontal).</p> <p style="text-align: center;">Unlocked position</p>  <p style="text-align: right;">CVX-0145A</p>
2	<p>Ensure that the ejectors are extended at an angle, but not all of the way.</p>  <p style="text-align: right;">CVX-0213B</p> <p>Caution: Extending the ejectors all of the way may result in ejector breakage when attempting to close them in step 4.</p>

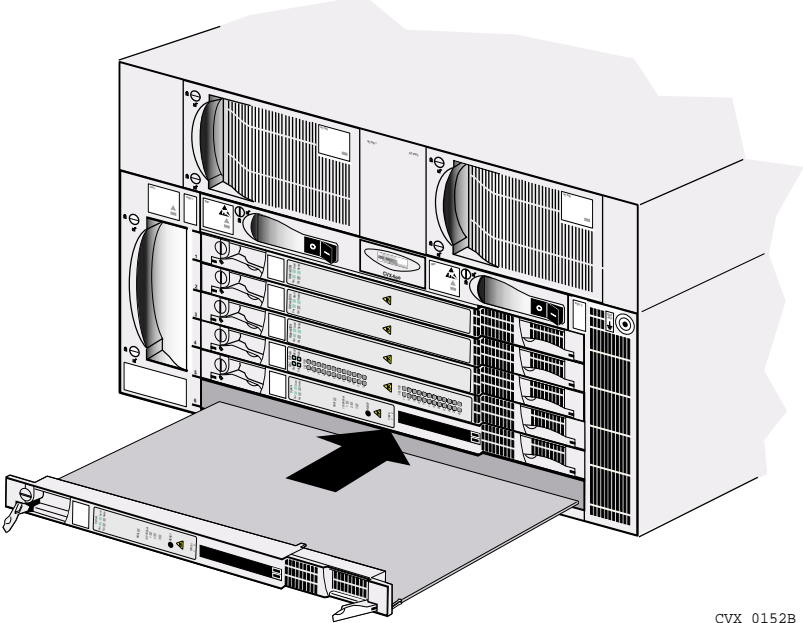
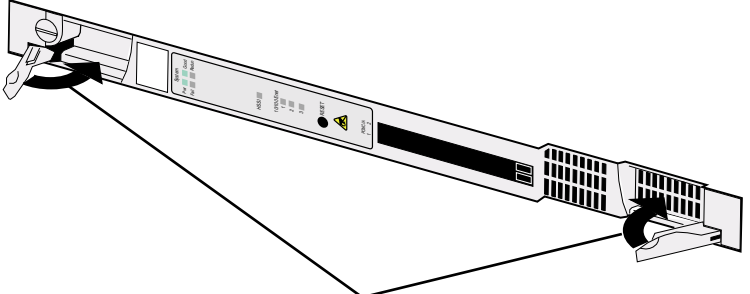
Step	Action
3	<p>Ensure that the latch pawl is in the card guide channel and slide the module into the chassis until its connector touches the chassis mid-plane.</p>  <p style="text-align: right;">CVX_0152B</p>
4	<p>Push the levers inward to fully engage the locking mechanism. The right lever will click when fully pushed in.</p>  <p style="text-align: center;">Close ejector levers</p> <p style="text-align: right;">CVX_0153C</p>
5	Using a flat-tip screwdriver, turn the locking screw 1/4 turn clockwise.
6	Insert the flash memory card in PCMCIA slot 1 in the upper SCC-SM.
7	Observe the LEDs on the SCC-SM to verify proper operation.

Reference

For information about the SCC-SM LEDs, see the [“Checking the LEDs”](#) on page 2-43.

Replacing the SCC-LTM/RLTM

If you need to replace the SCC-LTM or SCC-RLTM, note the configuration of installed network cabling before you disconnect any cables. This includes cabling to the following ports:

- Local 10/100 Mb/s Ethernet ports
- Console port
- HSSI port
- Alarm port
- T1 ports or E1 ports
- Optical ports

You will need to reinstall this cabling on the replacement SCC-LTM/RLTM.



Caution: Before removing the SCC-LTM or SCC-RLTM, you *must* first remove the corresponding SCC-SMs. The LTMs and RLTM are not hot-swappable (that is, you cannot change them while the system is running).

Removing the SCC-LTM or SCC-RLTM

To remove the SCC-LTM or SCC-RLTM, follow these steps:

Step	Action
1	Turn off power by turning off the switches on the PDU.
2	Disconnect any cables attached to the SCC-LTM/RLTM. Note: If you are using the alarm connections, you can leave the alarm wiring in place by removing the alarm connector block from the SCC-LTM/RLTM. Use a 1/8-inch flat-tip screwdriver to remove the alarm connector block.

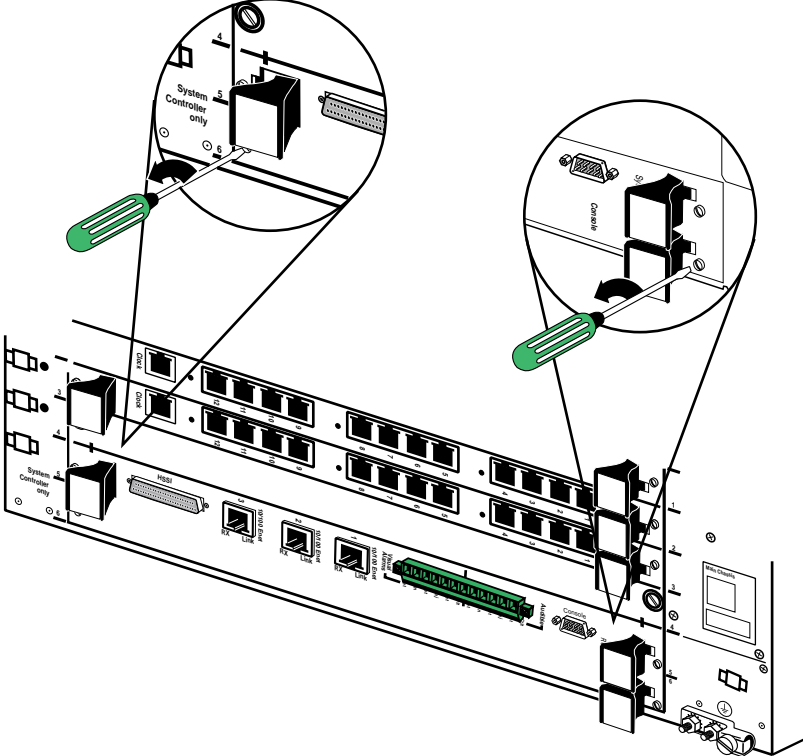
Step	Action
3	<p data-bbox="458 249 1133 279">Using a 1/16-inch flat-tip screwdriver, loosen the locking screws.</p>  <p data-bbox="1179 1072 1268 1090">CVX-0154B</p>

(continued)

Installing an SCC-LTM or SCC-RLTM

To install an SCC-LTM or SCC-RLTM, follow these steps:

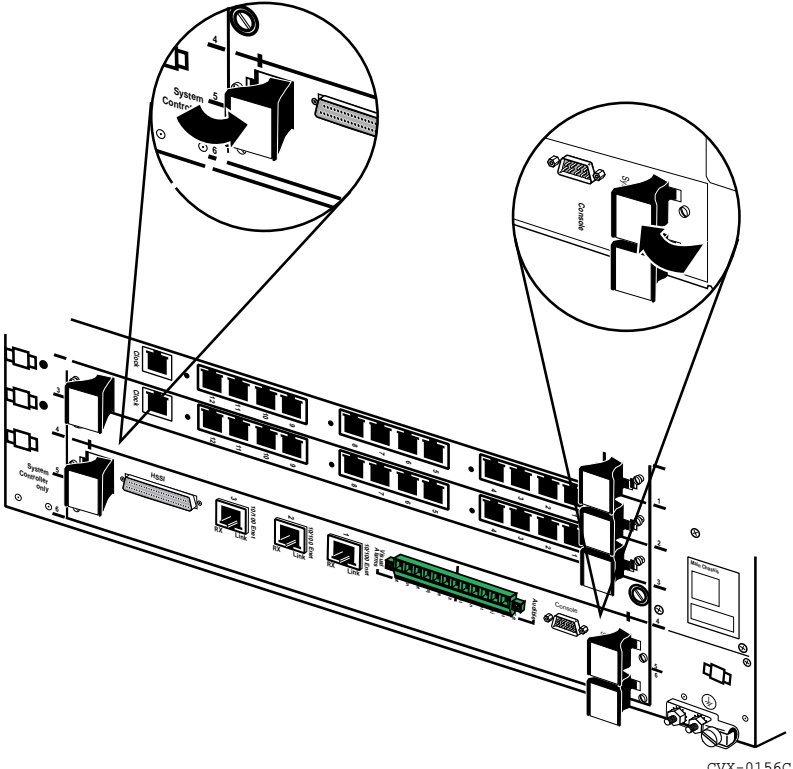
Step	Action
1	Make sure the power switches on the PDUs are both off.
2	Holding the SCC-LTM/RLTM, use the guides to align the sides of the module with either slot 5 or slot 6.
3	Grasp the top and bottom ejector levers and push them outward, then push the SCC-LTM/RLTM into the chassis until its connector touches the connector on the SCC-SM.
4	<p>Push the levers inward to fully engage the locking mechanism.</p> 

(continued)

Replacing Other Service Modules

The MACs and DAC-SMs provide the processing capabilities for the rear-installed LTMs. When you remove an online service module, the CVX 600 redirects processing to an adjacent secondary module that uses the same LTM. These service modules can occupy chassis slots 1 to 4.

Replacement Procedure

The procedure for replacing these service modules is the same as the procedure for replacing the SCC-SM.

Reference

See the *CVX Multi-Service Access Switch Product Description* for information on where to position the modules.



Caution: Do not install E1-DAC and DS1-DAC cards in the same chassis. Because the CVX switch synchronizes to one external clock, a CVX switch that contains both E1-DAC and DS1-DAC cards will not function properly, and is not supported.

Removing a Service Module

To remove a MAC or DAC-SM, follow these steps:

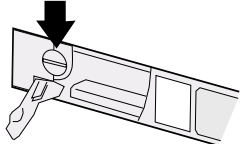
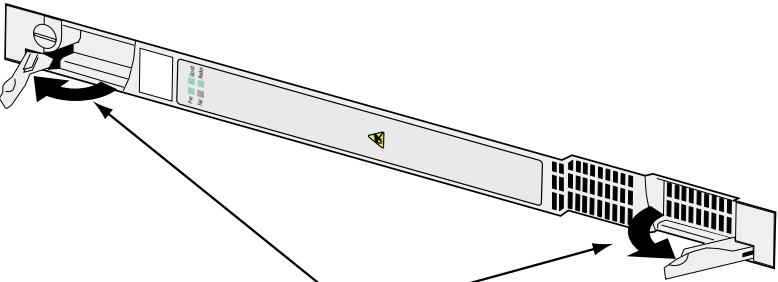
Step	Action
1	<p>Using a 1/4-inch flat-tip screwdriver, turn the locking screw in the upper left corner of the filler panel 1/4 turn counterclockwise.</p> <p style="text-align: center;">Unlocked position</p>  <p style="text-align: right;">CVX-0145A</p>
2	<p>Grasp the left and right ejector levers and push them outward to eject the service module. You will feel the module disconnect from the chassis mid-plane.</p>  <p style="text-align: center;">Open ejectors</p> <p style="text-align: right;">CVX-0158c</p>

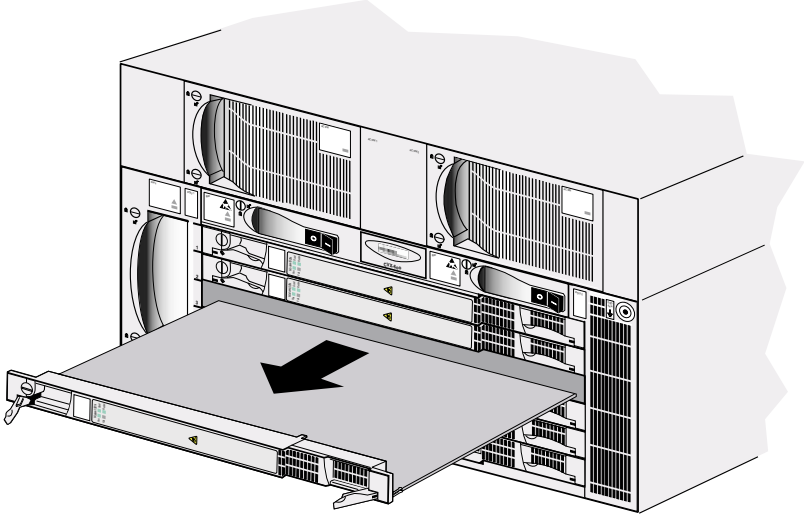
Step	Action
3	<p data-bbox="458 251 1232 279">Grasp the ejector levers and carefully slide the module out of the chassis.</p>  <p data-bbox="1153 864 1232 876">CVX-0159B</p>

Installing a Service Module

To install a MAC or DAC-SM, follow these steps:

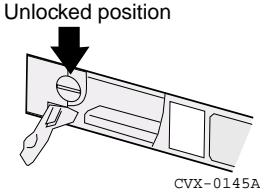
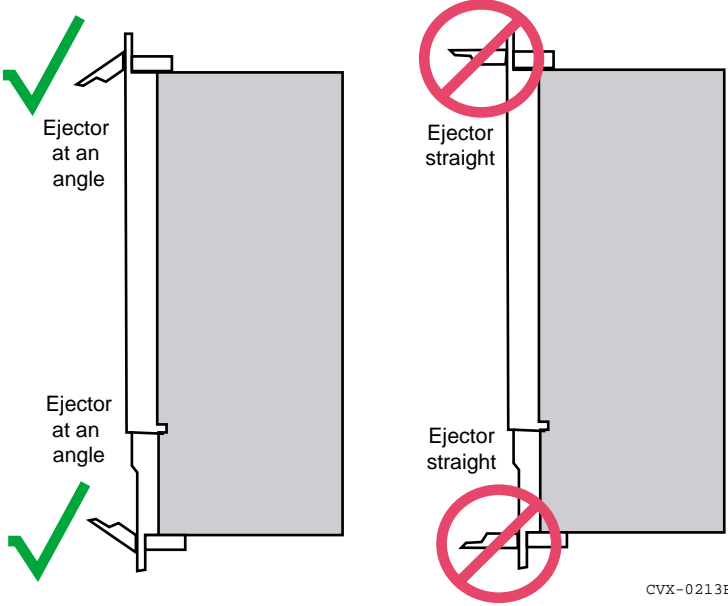
Step	Action
1	<p>Make sure that the locking screw is in the unlocked position (slot horizontal).</p> 
2	<p>Ensure that the ejectors are extended at an angle, but not all of the way.</p>  <p>Caution: Extending the ejectors all of the way may result in ejector breakage when attempting to close them in step 4.</p>

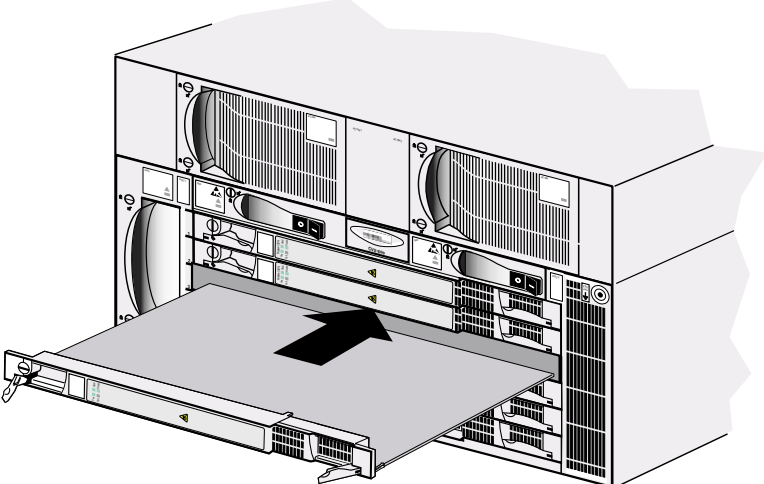
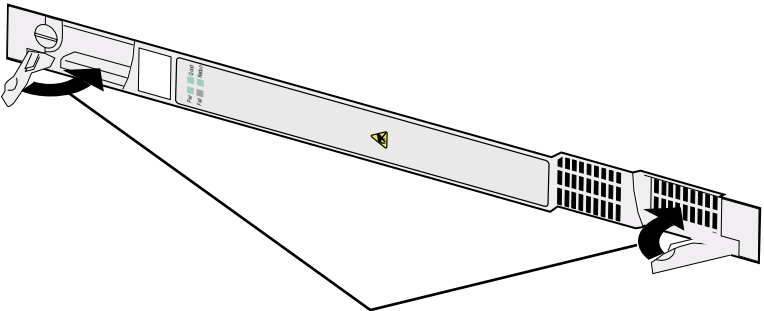
Step	Action
3	<p>Ensure that the latch pawl is in the card guide channel and slide the module into the chassis until its connector touches the chassis mid-plane.</p>  <p style="text-align: right;">CVX_0160B</p>
4	<p>Push the levers inward to fully engage the locking mechanism. The right lever will click when fully pushed in.</p>  <p style="text-align: center;">Close ejector levers</p> <p style="text-align: right;">CVX_0161C</p>
5	<p>Using a 1/4-inch flat-tip screwdriver, turn the locking screw 1/4 turn clockwise.</p>
6	<p>Observe the LEDs on the MAC or DAC-SM to verify proper operation.</p>

Reference

For information about the LEDs, see [“Checking the LEDs”](#) on page 2-43.

Replacing the DAC-LTM/-RLTM

If you need to replace an LTM or RLTM, note the configuration of installed network cabling before you disconnect any cables. You will need to reinstall this cabling on the replacement LTM.



Caution: Before removing the LTM or RLTM, you must first remove the front-installed service module.

References

For more information on removing the service module, see [“Replacing the SCC-SM”](#) on [page 3-11](#) or [“Replacing Other Service Modules”](#) on [page 3-21](#).

Installing a DAC-LTM or DAC-RLTM

To install a DAC-LTM or DAC-RLTM, follow these steps:

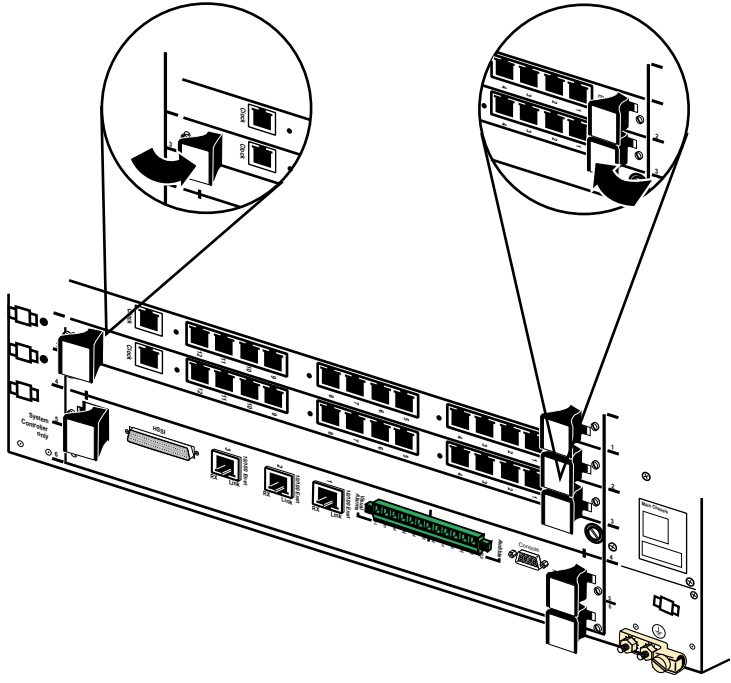
Step	Action
1	Holding the module, use the guides to align the sides of the module with the appropriate slot.
2	Grasp the left and right ejector levers and pull them outward, then push the LTM or RLTM into the chassis until its connector touches the connector on the service module.
3	Push the levers inward to fully engage the locking mechanism. 

(continued)

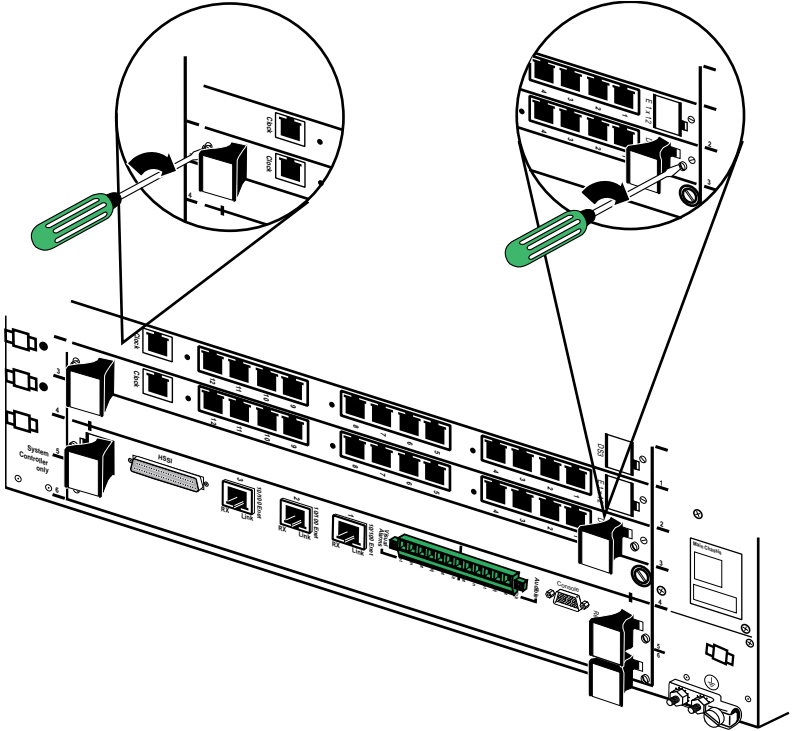
Step	Action
4	<p data-bbox="458 248 1276 309">Use a flat-tip screwdriver to tighten the two locking screws on the front of the LTM or RLTM.</p>  <p data-bbox="1172 1072 1258 1090">CVX-0165B</p>
5	Reattach any network cabling and alarm wiring used on the LTM or RLTM you just removed.
6	Observe the LEDs on the service module to verify proper operation.

Reference

For more information about the DS1, E1, and DS3 LEDs, see [“Checking the LEDs”](#) on page 2-43.

Replacing the Fan Module

Description

The CVX 600 fan module contains two fans and is located on the left side of the chassis.



Caution: A malfunctioning fan module can cause the entire chassis to overheat. This condition can lead to system and network failures. If you detect an overheating condition in the chassis, have a qualified service technician inspect the fan module as soon as possible.

Removing the Fan Module

To remove the fan module, follow these steps:

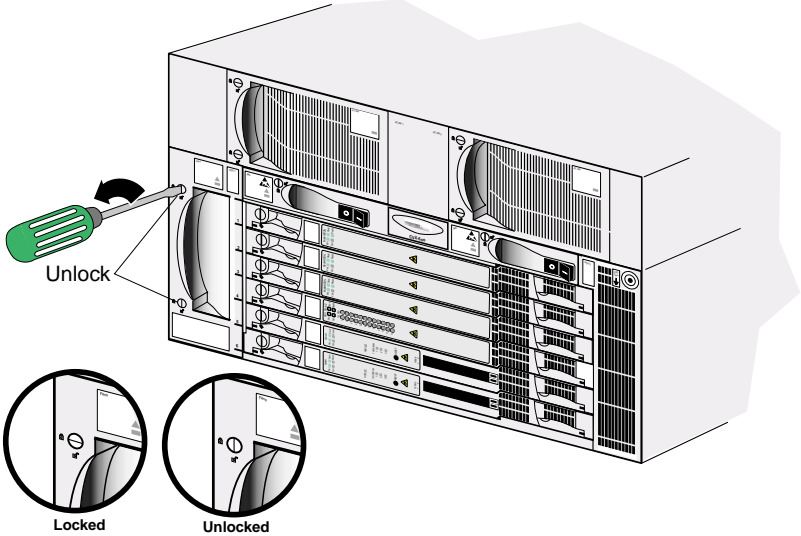
Step	Action
1	<p data-bbox="458 392 1125 447">Using a flat-tip screwdriver, turn the two locking screws 1/4 turn counterclockwise to unlock.</p>  <p data-bbox="515 730 582 748">Unlock</p> <p data-bbox="525 982 582 999">Locked</p> <p data-bbox="672 982 739 999">Unlocked</p> <p data-bbox="1139 1017 1229 1034">CVX-0166B</p>

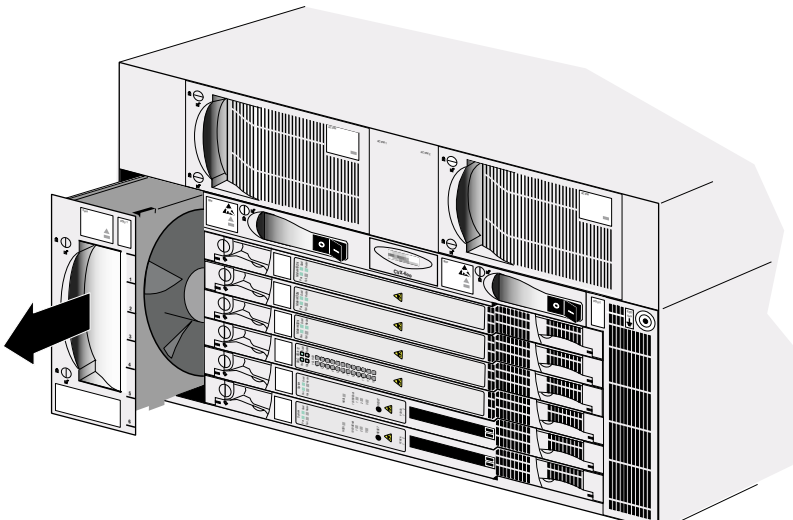
Step	Action
2	<p>Grasp the fan module by the handle and pull firmly until you feel the fan module disconnect from the chassis.</p> <p>Warning: The fans will spin for a short time as you slide the fan module out of the chassis. Be careful not to place your hands or fingers near the fan blades.</p>
3	<p>Slide the fan module out of the chassis.</p>  <p>CVX-0167B</p>

Installing a Fan Module

To install a fan module, follow these steps:

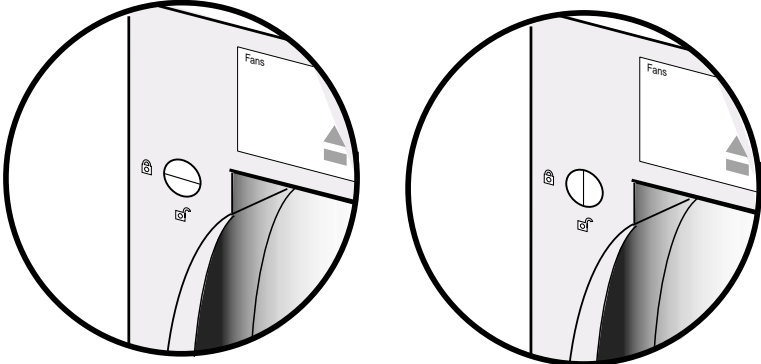
Step	Action
1	<p data-bbox="458 392 1273 418">Make sure that the locking screws are in the unlocked position (slot is vertical).</p> <div data-bbox="486 440 1240 805"></div> <p data-bbox="611 812 741 847">Locked</p> <p data-bbox="983 812 1153 847">Unlocked</p> <p data-bbox="1168 878 1253 895">CVX-0168A</p>

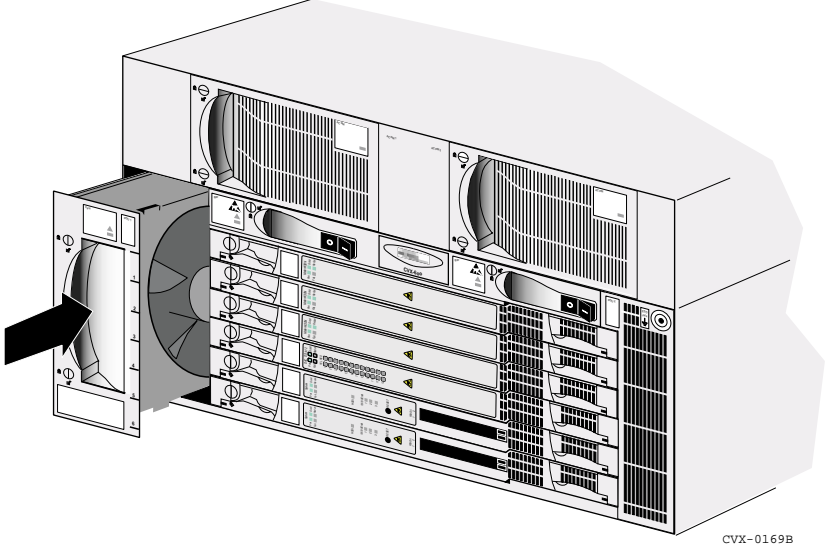
Step	Action
2	<p>Slide the replacement fan module into the chassis until you feel the module touch the fan connector in the chassis.</p>  <p style="text-align: right;">CVX-0169B</p>
3	<p>Firmly push on the fan module's front panel until you feel the module connect to the fan connector. The front panel of the fan module should be flush with the front of the chassis.</p>
4	<p>Using a flat-tip screwdriver, turn the locking screws 1/4 turn clockwise.</p>
5	<p>Verify that the replacement fan module is operating properly. The green LED should be on, and air should be exiting the chassis vents.</p>

Replacing a PDU Module

Description

The CVX 600 contains two PDU (circuit breaker) modules, which are located near the top center of the front of the chassis.

Removing the PDU Module

To remove the PDU module, follow these steps:

Step	Action
1	Make sure that the switch is turned off.
2	Using a flat-tip screwdriver, turn the locking screw 1/4 turn counterclockwise to unlock.

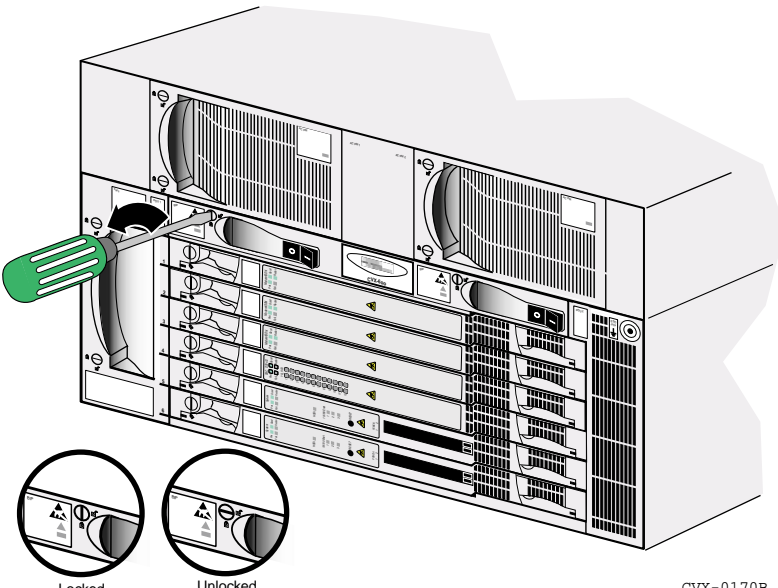

The diagram illustrates the front of a CVX 600 chassis with several PDU modules. A green screwdriver is shown turning a locking screw on one of the PDU modules. Two circular insets at the bottom left show the 'Locked' and 'Unlocked' states of the screw. The 'Locked' inset shows the screw head with a small tab protruding, while the 'Unlocked' inset shows the screw head with the tab retracted. The chassis is shown in a perspective view, with the PDU modules located near the top center of the front panel.

CVX-0170B

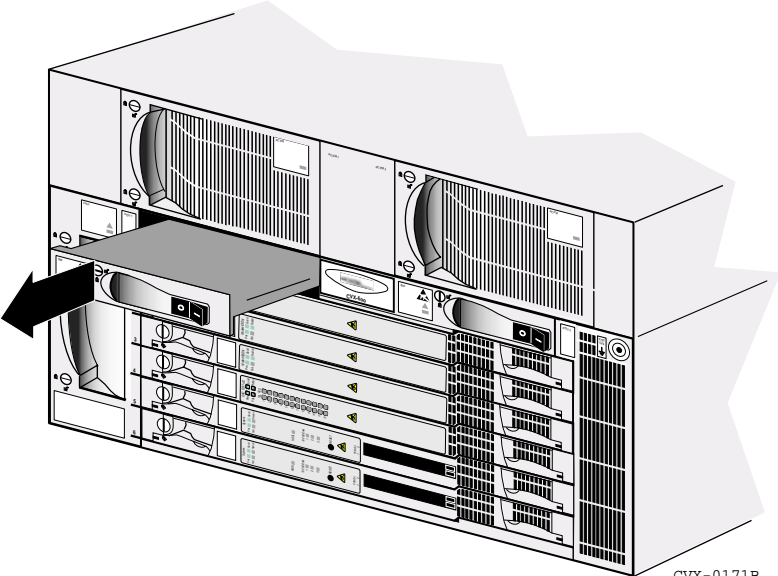
Step	Action
3	Grasp the PDU module by the handle and pull firmly until you feel it disconnect from the chassis.
4	Slide the PDU module out of the chassis.  <p>CVX-0171B</p>

Installing a PDU Module

To install a PDU module, follow these steps:

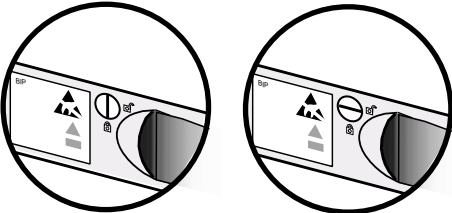
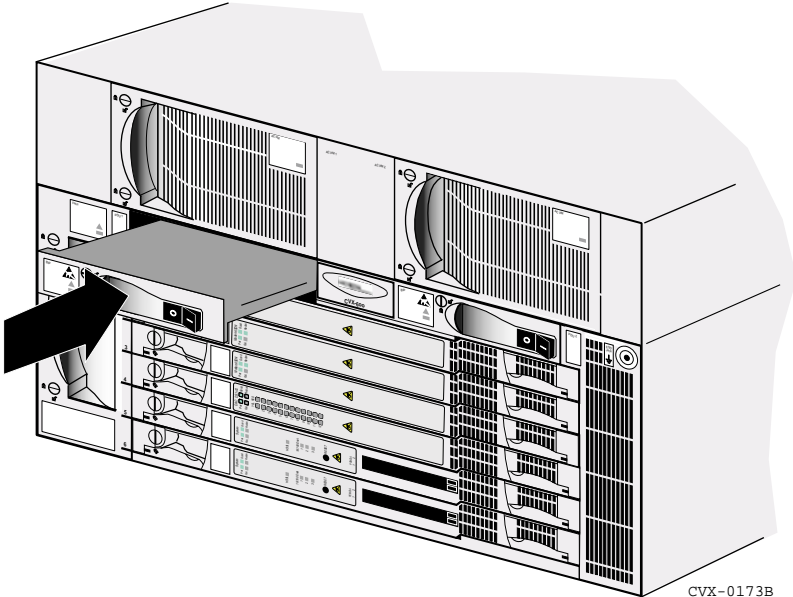
Step	Action
1	<p>Make sure that the locking screw is in the unlocked position (slot is horizontal).</p> <div data-bbox="639 439 1086 652"></div> <p data-bbox="705 661 782 683">Locked</p> <p data-bbox="933 661 1036 683">Unlocked</p> <p data-bbox="1005 699 1093 713">CVX-0172A</p>
2	<p>Slide the replacement module into the chassis until you feel it touch the connector in the chassis.</p> <div data-bbox="468 817 1253 1416"></div> <p data-bbox="1148 1402 1236 1416">CVX-0173B</p>
3	<p>Firmly push on the PDU module's front panel until you feel the module connect to the chassis connector. The front panel of the PDU module should be flush with the front of the chassis.</p>

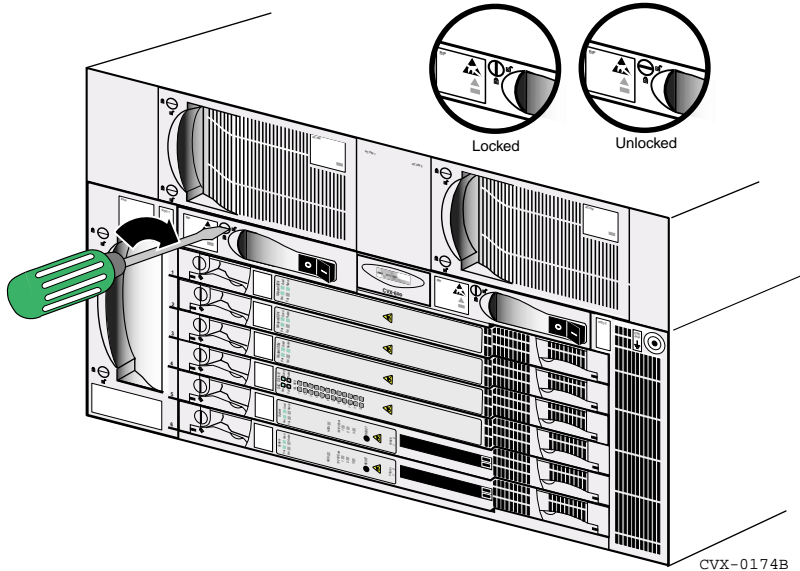
Step	Action
4	<p data-bbox="456 251 1185 277">Using a flat-tip screwdriver, turn the locking screw 1/4 turn clockwise.</p>  <p data-bbox="1149 841 1249 859">CVX-0174B</p>
5	Verify that the red LED is on.
6	Switch the PDU on, and verify that the green LED comes on.

Replacing a Power Module

Description

If equipped with the AC module, the CVX 600 contains two replaceable power modules, which are located in the top center of the front of the chassis.

Removing the Power Module

To remove a power module, follow these steps:

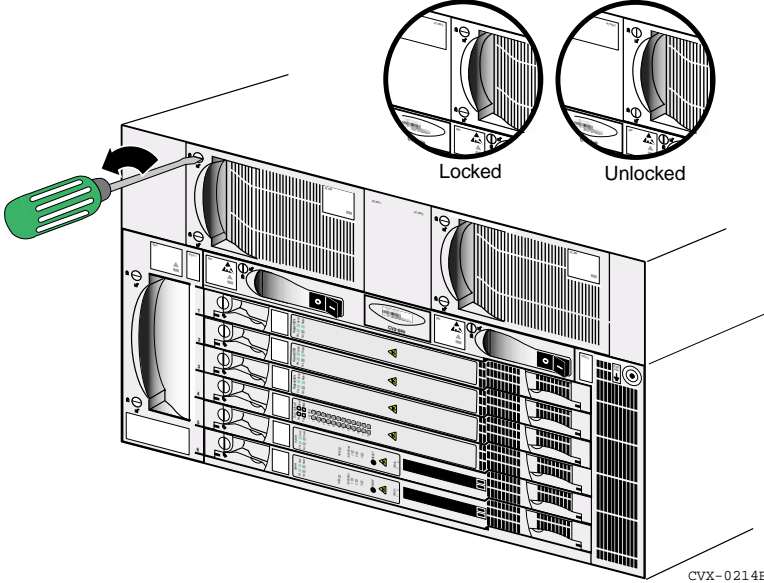
Step	Action
1	<p data-bbox="458 713 1276 743">Using a flat-tip screwdriver, turn the locking screws 1/4 turn counterclockwise.</p>  <p data-bbox="1172 1329 1253 1345">CVX-0214B</p>

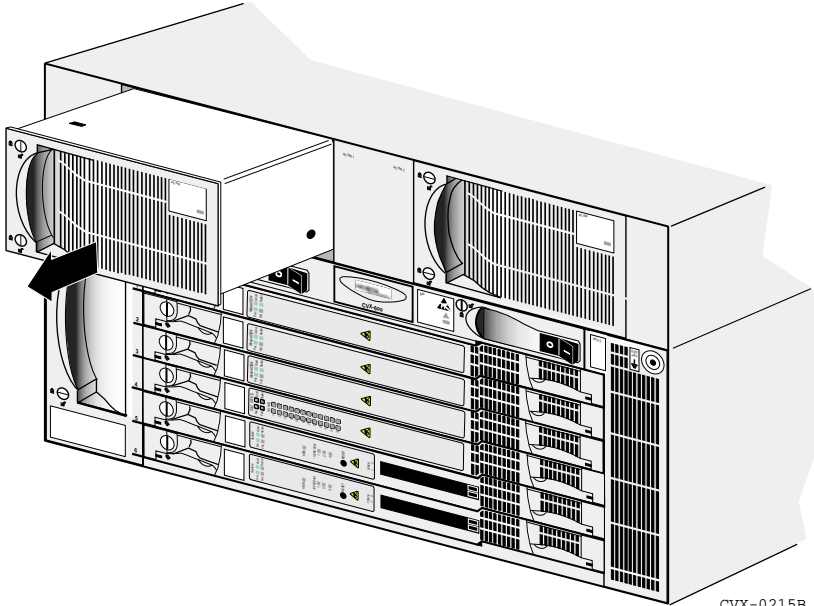
Step	Action
2	Grasp the power module by the handle and pull firmly until you feel it disconnect from the chassis.
3	Slide the power module out of the chassis.  <p>The diagram illustrates a server chassis with multiple power modules. One power module is shown being pulled out of its bay. A black arrow points to the left, indicating the direction of movement. The power module has a handle on the left side and a fan grille on the right. The chassis has a front panel with various components, including a power button and indicator lights. The text 'CVX-0215B' is visible in the bottom right corner of the diagram.</p>

Installing a Power Module

To install a power module, follow these steps:

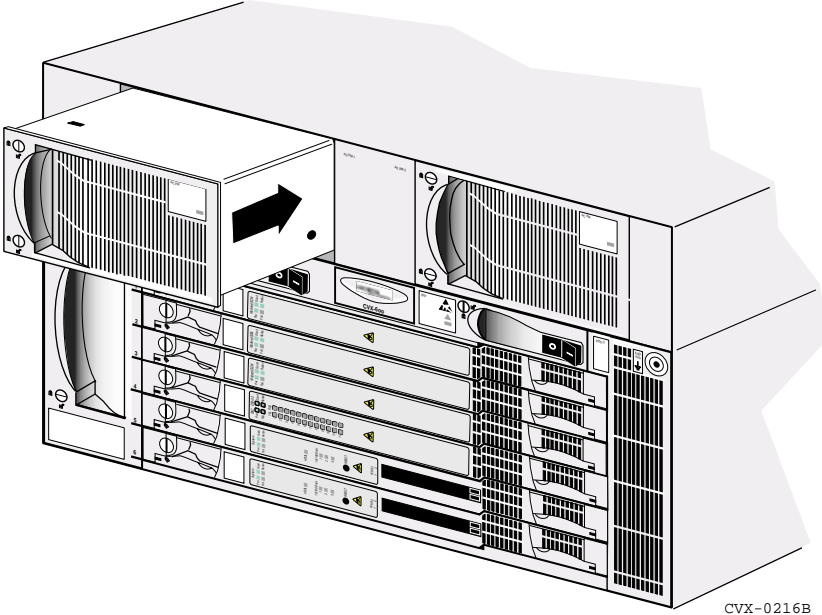
Step	Action
1	Make sure that the locking screws are in the unlocked position (slots are vertical).
2	Slide the replacement module into the chassis until you feel it touch the connector in the chassis.  <p>CVX-0216B</p>
3	Firmly push on the power module's front panel until you feel the module connect to the chassis connector. The front panel of the power module should be flush with the front of the chassis.

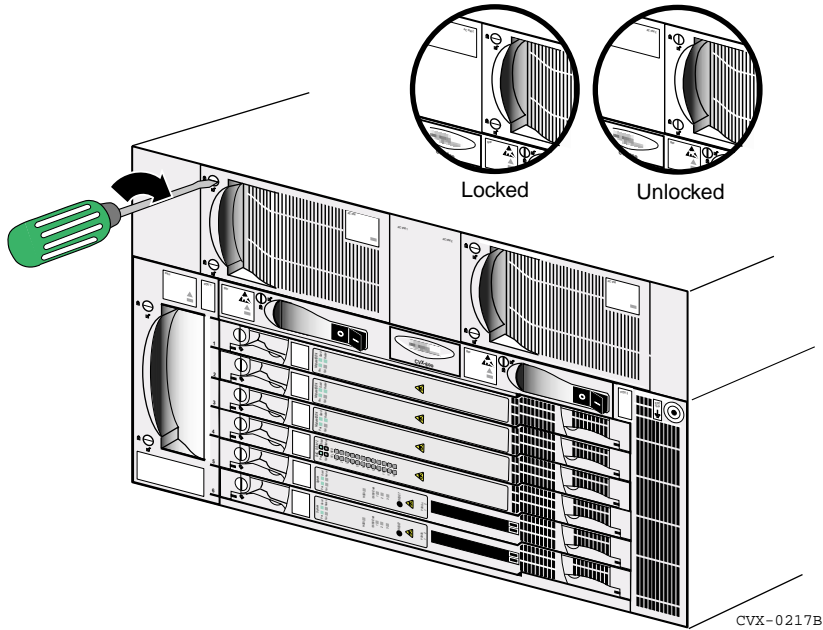
Step	Action
4	<p data-bbox="458 249 1196 279">Using a flat-tip screwdriver, turn the locking screws 1/4 turn clockwise.</p>  <p data-bbox="1182 909 1273 928">CVX-0217B</p>
5	<p data-bbox="458 960 722 986">Verify that the LED is on.</p>

Ordering Replacement Components

How to Order

If necessary, you can order CVX 600 replacement components from Nortel Networks. See “[Customer Services](#)” on [page xviii](#) for information about contacting Nortel Networks.

Appendix A

Technical Specifications

About This Appendix

Introduction

This appendix provides the technical specifications for the CVX 600.

Topics

This appendix covers the following topics:

Topic	Page
Chassis Specifications and Clearances	A-2
Environmental Specifications	A-3
Cooling Requirements	A-4
Electromagnetic Emissions and Radio Frequency	A-5
Cable Specifications	A-6
Tandem CVX to RAS CVX Crossover Cable	A-14
Audible and Visual Alarm Interface Specifications	A-16
Power Specifications	A-17
SCC-LTM/-RLTM Interfaces	A-18
DAC-LTM/-RLTM External Clock Interface	A-19

Chassis Specifications and Clearances

Dimensions, Weight, Slot Capacity

The following table lists the dimensions, weight, and slot capacity of the CVX 600 chassis:

Attribute	Measurement
Height with AC module	10.5 in. (26.7 cm)
Height without AC module	7.0 in. (17.8 cm)
Width	17.3 in. (43.94 cm)
Depth	16.25 in. (41.3 cm)
Weight: chassis with 6 SMs and AC power	70 lb (31.7 kg)
Slots	Two for SCCs, combinations of up to 4 DACs and MACs

Clearance

The chassis must have enough clearance around it to ensure proper airflow for cooling. The following table lists the minimum clearance requirements for the CVX 600 chassis:

Area	Minimum Clearance
Left side (location of fans)	2.0 in. (5.08 cm)
Right side	2.0 in. (5.08 cm)
Top	None
Back	6.0 in. (15.24 cm)
Back (for servicing)	12.0 in. (30.48 cm)

Environmental Specifications

Specifications

The following table lists the environmental specifications for the CVX 600:

Attribute	Measurement
Operating temperature	23° to 104°F (-5° to 40°C)* stable
Operating altitude	0 to 8000 ft (0 to 2438.4 m)
Storage altitude	10,000 ft (3000 m) maximum
Storage temperature	-40° to 158°F (-40° to 70°C)
Operating humidity	90% maximum relative humidity, noncondensing
Storage humidity	95% maximum relative humidity, noncondensing
Free fall/drop	ISO 4180-S, NSTA 1A
Vibration	IEC 68-2-6/34
Shock/bump	IEC 68-2-27-29

* -5°C is for short-term operation only.

Cooling Requirements

Need for Ventilation

The CVX 600 is a high performance access switch, that produces a significant amount of heat. Providing sufficient cooling ventilation is very important when installing the equipment.

Methods of Cooling

The two typical ways of cooling the equipment are:

- General cooling — cool air is supplied by air conditioning the entire equipment room. Open racks are recommended for general cooling.
- Dedicated cooling — cool air is directly fed to a closed cabinet containing the CVX 600 equipment. If using this method, arrange the cabling so as to minimize its effect on air flow inside the cabinet. Using a fan to move air through the cabinet is recommended, especially if several CVX 600 switches are installed in one cabinet. All cabinet doors should be closed, and all cabinet panels in place.

Airflow

Regardless of the method of cooling used, make sure that minimum clearance requirements are met and that airflow at the CVX 600 is at least 200 CFM.

Electromagnetic Emissions and Radio Frequency

CVX 600 Requirements

The CVX 600 meets the following requirements for electromagnetic emissions and radio frequency:

- FCC Part 15, Subpart B
- EN 55022: 1994/A1:1995/A2:1997 Class B ITE emissions requirements
- EN 50082-1: 1992 EMC residential, commercial, and light industrial generic immunity standard
- EN 61000-4-3: RF Electromagnetic Field: 3V/m, 80-1000 MHz, 1 KHz, 80% AM
- ENV 50204: RF Electromagnetic Field, keyed carrier: 900 \pm 5 MHz, 200 Hz PM, 50% duty cycle

Cable Specifications

Cables Supplied by Nortel Networks

The CVX 600 includes the following cables:

- 15 ft DB-9 to DB-9 serial crossover cable (null-modem cable) to connect the CVX 600 DB-9 RS-232 console port to a DB-9 RS-232 management console plug
- 10 ft DB-9 to DB-25 straight-through modem cable to connect the CVX 600 DB-9 RS-232 console port to an external modem
- 10 ft RJ-45 to RJ-45 crossover cable to connect a CVX 600 Ethernet port to a PC Ethernet adapter
- AC power cables to connect the CVX 600 to external AC power

Cables Supplied by the Customer

You must supply the following cables:

- T1, E1, and T3 cables
- HSSI cable
- DC power and grounding cables
- Rack-grounding cable from each CVX 600 chassis to the installation site's grounding point
- Cables for the audible and visual alarms
- Optical cables

Management Console Cable Specifications

The SCC-RLTM has a single console interface. The interface uses a DB-9 plug connector that provides an RS-232 serial connection. The CVX 600 console port allows you to connect to any VT100-compatible console device for direct console access, or to any modem (AT or Hayes compatible) for remote dial-up access.

The following figure shows the DB-9 console interface connector:

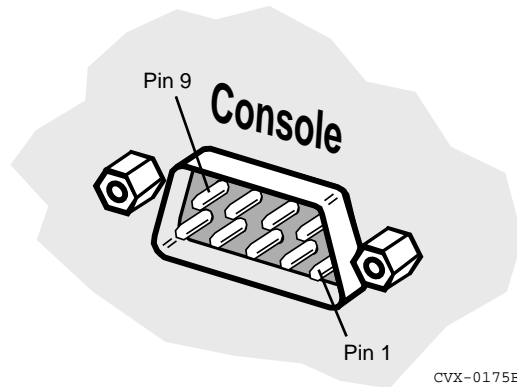

DB-9 Pin and Signal Assignments

The following table lists the pin and signal assignments for the DB-9 console interface connector:

Pin	Signal	To Signal
1	DCD (data carrier detect)	DCD
2	TXD (transmit data)	RXD
3	RXD (receive data)	TXD
4	DSR (data set ready)	DTR
5	GND (signal ground)	GND
6	DTR (data terminal ready)	DSR
7	CTS (clear to send)	RTS
8	RTS (request to send)	CTS
9	Not used	Not used

DB-9 to DB-25 Pin and Signal Assignments

The following table lists the pin and signal assignments for the DB-9 to DB-25 console interface connector:

Pin on DB-9 Connector	Signal Name	Pin on DB-25 Connector
1	DCD (data carrier detect)	8
2	RXD (receive data)	3
3	TXD (transmit data)	2
4	DTR (data terminal ready)	20
5	GND (signal ground)	7
6	DSR (data set ready)	6
7	RTS (request to send)	4
8	CTS (clear to send)	5
9	RI (ring indicator)	22

HSSI Interface

The following figure shows the HSSI connector:

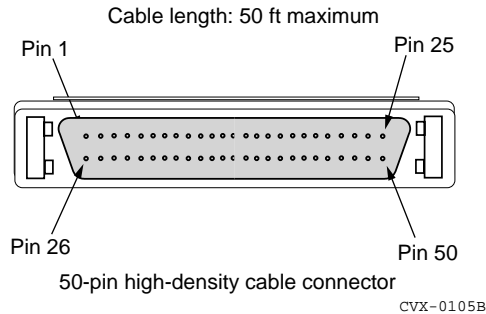

HSSI DTE to DCE Pin and Signal Assignments

The following table lists the pin and signal assignments for the HSSI DTE to DCE interface cable:

Nortel Networks Termination		Remote Termination	
Pin	Signal	Pin	Signal
1	Signal Ground	1	Signal Ground
26	Signal Ground	26	Signal Ground
2	Receive timing+	2	Receive timing+
27	Receive timing-	27	Receive timing-
3	DCE Available+	3	DCE Available+
28	DCE Available-	28	DCE Available-
4	Received Data+	4	Received Data+
29	Received Data-	29	Received Data-
5	Line Loopback+	5	Line Loopback+
30	Line Loopback-	30	Line Loopback-
6	Send Timing+	6	Send Timing+
31	Send Timing-	31	Send Timing-
7	Signal Ground	7	Signal Ground
32	Signal Ground	32	Signal Ground

(continued)

Nortel Networks Termination		Remote Termination	
Pin	Signal	Pin	Signal
8	DTE Available+	8	DTE Available+
33	DTE Available-	33	DTE Available-
9	Terminal Timing+	9	Terminal Timing+
34	Terminal Timing-	34	Terminal Timing-
35	Loopback CKT A-	35	Loopback CKT A-
11	Send Data+	11	Send Data+
36	Send Data-	36	Send Data-
12	Loopback CKT B+	12	Loopback CKT B+
37	Loopback CKT B-	37	Loopback CKT B-
24	Test Mode+	24	Test Mode+
49	Test Mode-	49	Test Mode-
13	Signal Ground	13	Signal Ground
38	Signal Ground	38	Signal Ground
19	Signal Ground	19	Signal Ground
44	Signal Ground	44	Signal Ground
25	Signal Ground	25	Signal Ground
50	Signal Ground	50	Signal Ground

Ethernet 10/100BASE-TX Interface Cable Specifications

The Ethernet 10/100BASE-TX interfaces provide unshielded twisted pair (UTP) support.

The following figure shows the Ethernet 10/100BASE-TX interface connector:

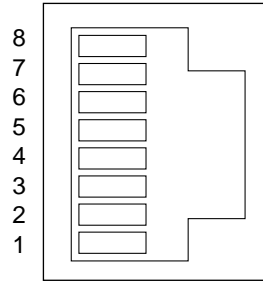

CVX-0103A

Ethernet 10/100BASE-TX Pin and Signal Assignments

The following table lists the pin and signal assignments for these interfaces:

Pin	Standard Interface Signal	Crossover
1	TD+ (Transmit to UTP)	RD+ (Receive from UTP)
2	TD- (Transmit to UTP)	RD- (Receive from UTP)
3	RD+ (Receive from UTP)	TD+ (Transmit to UTP)
4	Not used	Not used
5	Not used	Not used
6	RD- (Receive from UTP)	TD- (Transmit to UTP)
7	Not used	Not used
8	Not used	Not used

E1 and T1 Interface Line Specifications

The DS1-DAC-LTM, E1-DAC-LTM, and SCC-T1-RLTM interfaces provide UTP support. The following figure shows the RJ-45 interface on these modules:

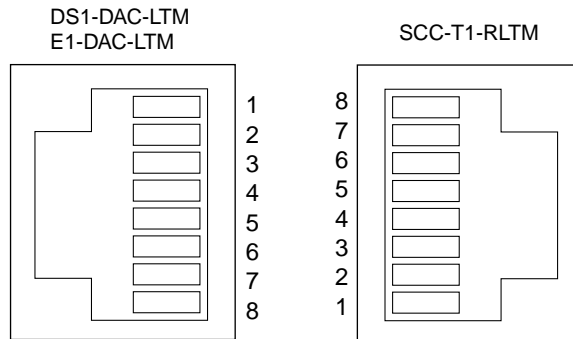

CVX-0104B

RJ-45 Pin and Signal Assignments

The following table lists the pin and signal assignments for E1 and T1 interfaces:

Pin	Standard Interface Signal	E1, T1 Signal
1	Rx Ring	Rx Ring
2	Rx Tip	Rx Tip
3	Not used	Not used
4	Tx Ring	Tx Ring
5	Tx Tip	Tx Tip
6	Not used	Not used
7	Not used	Not used
8	Not used	Not used

E1 and T1 Shielded Cable Specifications

Shielded cabling is an EMI requirement for CVX 600 E1 network configurations, but is optional for T1 network configurations.

DS3 Coaxial Cable Specifications

The DS3 coaxial cable must meet the requirements of ANSI Standard T1.102-1993 and the *Telcordia Technical Reference GR-1402*. The coaxial cable must have an impedance of 75 ohms and a maximum length of 450 feet.

Optical Cable Specifications

Optical cables should meet industry standard requirements for single-mode fiber with SC connectors.

Tandem CVX to RAS CVX Crossover Cable

Introduction

If you need a crossover cable to send data from a tandem CVX 600 to a RAS CVX 600, you must build the cable using the information in this section. Nortel Networks does not supply this cable.

Tool and Parts Needed

To make the cable, you need the following items:

- CAT 5-conductor cable
- (2) RJ-45 connectors
- RJ-45 crimp tool

Pin Data

To assemble the cable, you also need to know the pin connections. The following table provides the tandem CVX switch to RAS CVX switch pin data.

From	To
Pin 1	Pin 4
Pin 2	Pin 5
Pin 4	Pin 1
Pin 5	Pin 2

RJ-45 Pin Numbering

The following figure shows the numbering of the RJ-45 connector:

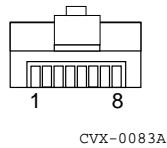

Note: Pins 3, 6, 7, and 8 are not used.

Audible and Visual Alarm Interface Specifications

The following figure shows the alarm interface connector with both styles of labeling.

Alarm Interface Connector



Signals

The following table lists the positions and signal names on the alarm interface connector:

Position	Audible Signal	Position	Visual Signal
1 (Signal)	Critical	7 (Signal)	Critical
2 (Return)	Return	8 (Return)	Return
3 (Signal)	Major	9 (Signal)	Major
4 (Return)	Return	10 (Return)	Return
5 (Signal)	Minor	11 (Signal)	Minor
6 (Return)	Return	12 (Return)	Return

Reference

See [“Connecting Alarms”](#) on [page 2-2](#) for more information.

Power Specifications

Power Options

The CVX 600 is powered by an AC or DC power source. Use the information in this section to plan for AC or DC power.

AC Power Requirements

The installation site must meet the following AC power requirements:

- Input voltage: 85 to 264 VAC
- Proximity to wall receptacle: within 6 ft (1.8 m)
- Line frequency: 47 to 63 Hz
- Fuses: internal (not accessible)

DC Power Requirements

The installation site must meet the following DC power requirements:

- Nominal -48 VDC; range: -37 VDC to -56 VDC; 0.5 kW maximum
- DC current: 10 A at -48 VDC



Caution: Input DC voltage must not exceed -72 VDC.

SCC-LTM/-RLTM Interfaces

The following table lists the interfaces on the SCC-LTM and SCC-RLTM:

Interface	Description
Console	<ul style="list-style-type: none"> One DB-9 RS-232 serial port
HSSI (SCC-HSSI-RLTM)	<ul style="list-style-type: none"> One port 50-pin connector Status LED on the SCC-SM for the SCC-HSSI-RLTM
10/100BASE-TX	<ul style="list-style-type: none"> Switched IEEE 802.3 with autosensing capabilities RJ-45 connectors MIPS R5000, 64 bit, 180 MHz MDI-X Full-duplex operation Status LEDs on the SCC-SM
Alarms	<ul style="list-style-type: none"> Up to six independent alarm signals: three audible, three visual Gold-clad silver-alloy contacts <p>Note: The contacts on the terminal block are rated at 30 VAC and have a maximum current rating of 1 A. The circuit connecting the alarms must meet the safety extra-low voltage (SELV) requirements. The wires connecting the alarms must be the appropriate gauge for alarm devices.</p>
Clock	<p>The following applies to all DAC LTMs with an external clock port:</p> <ul style="list-style-type: none"> The external clock circuitry contains a standard T1/E1 LIU device with receive TIP/RING terminated at 120 ohms (incoming twisted pair). T1 clock rate = 1.544 MHz E1 clock rate = 2.048 MHz Port is hardwired for Bipolar Mode only. Port uses B8ZS/HDB3 encoding/decoding. <p>The external clock port meets or exceeds specifications in ANSI T1.403 and T1.408; ITU I.431, G.703, G.736, G.775 and G.823; ETSI 300-166 and 300-233; and AT&T Pub 62411.</p>

DAC-LTM/-RLTM External Clock Interface

The following applies to all DAC LTMs and RLTM with an external clock port:

- The external clock circuitry contains a standard T1/E1 LIU device with receive TIP/RING terminated at 120 ohms (incoming twisted pair).
- T1 clock rate = 1.544 MHz
- E1 clock rate = 2.048 MHz
- Port is hardwired for Bipolar Mode only.
- Port uses B8ZS/HDB3 encoding/decoding.

The external clock port meets or exceeds specifications in ANSI T1.403 and T1.408; ITU I.431, G.703, G.736, G.775 and G.823; ETSI 300-166 and 300-233; and AT&T Pub 62411.

A

- AC and DC power [1-12](#)
- AC power module [1-3](#)
- AC power requirements [A-17](#)
- airflow requirements [A-4](#)
- alarm interface
 - connecting [2-2](#)
 - specifications [A-16](#)
- anchor kits, for PTE 2000 rack [1-9](#)
- antistatic wrist strap, attaching [3-2](#)

B

- balun [2-10](#)

C

- cable mounts [2-27](#)
- cables
 - connecting to a DC power source [2-21](#)
 - connecting to a HSSI interface [2-12](#)
 - connecting to an external AC power supply [2-25](#)
 - connecting to an OC3 interface [2-13](#)
 - connecting to an STM interface [2-13](#)
 - connecting to DS1 interfaces [2-9](#)
 - connecting to DS3 interfaces [2-11](#)
 - connecting to E1 interfaces [2-10](#)
 - connecting to Ethernet interfaces [2-8](#)
 - routing [2-27](#)
- chassis
 - connecting power to [2-16](#)
 - grounding for DC power [2-17](#)
 - installing [1-18](#)
 - overview [1-2](#)
 - rack mounting [1-20](#)
 - specifications [A-2](#)

- circuit breakers [1-3](#)
- computer rack
 - mounting the CVX 600 in [1-22](#)
- console port, connecting to [2-32](#)
- CVX 600
 - dimensions [A-2](#)
 - installing [1-18](#)
 - on a flat surface [1-18](#)
 - preparations for [1-14](#)
 - mounting in a rack [1-20](#)
 - regulatory and compliance information [iii](#)
 - shipment contents [1-15](#)
 - site requirements [1-5](#)
 - weight [A-2](#)
- CVX 600 chassis [1-2](#)

D

- DC power requirements [A-17](#)
- digital access card (DAC)
 - DAC-RLTM interfaces [A-19](#)
- DS1 interface specifications [A-12](#)
- DS3 coaxial cable specifications [A-13](#)

E

- E1 shielded cable specifications [A-13](#)
- E1 shielded cabling [2-10](#)
- electromagnetic emissions and radio frequency specifications [A-5](#)
- environmental specifications [A-3](#)
- Ethernet interface
 - connecting equipment to [2-41](#)
 - specifications [A-11](#)
- external AC power supply

connecting the CVX 600 to [2-26](#)

F

fan module [1-3](#)

fan module, replacing [3-31](#)

filler panels, installing and removing [3-4](#)

flash memory cards, installing and removing [2-29](#)

G

grounding location [2-17](#), [2-18](#), [2-19](#)

grounding the chassis for DC power

using the compression terminal [2-19](#)

using the NEBS-compliant dual-connector posts [2-18](#)

H

HSSI interface

connecting to [2-12](#)

specifications [A-9](#)

I

installation [1-23](#)

in a rack [1-20](#)

mounting hardware [1-17](#)

on a flat surface [1-18](#)

service console [1-16](#)

tools and equipment for [1-16](#)

unpacking the shipment [1-14](#)

interfaces, connecting to
10/100BASE-T [2-8](#)

DS1 [2-9](#), [2-10](#)

DS3 [2-11](#)

E1 [2-10](#)

HSSI [2-12](#)

L

light-emitting diodes (LEDs), checking [2-43](#)

line termination modules (LTMs), replacing [3-27](#)

M

management console cable specifications [A-7](#)

modem

connecting to the CVX 600 [2-37](#)

parameters [2-37](#)

mounting options [1-7](#)

N

network cables, connecting to interfaces [2-7](#)

O

Optical DAC [2-51](#)

optical interface [2-13](#)

Optical SCC-II [2-48](#)

P

PC, connecting to the CVX 600 [2-35](#)

PDU [1-3](#), [2-16](#), [2-25](#), [2-42](#)

pin assignments

alarm interface connector [A-16](#)

Ethernet 10/100BASE-TX interface cable [A-11](#)

Ethernet interface cable [A-11](#)

HSSI DTE to DCE interface cable [A-9](#)

power

connecting to an AC power source [2-25](#)

connecting to the CVX 600 [2-16](#)

grounding the chassis for DC power [2-17](#)

power cable

connecting to a DC power source [2-22](#)

PTE 2000 rack [1-8](#)

R

rack cooling requirements [1-11](#)

rack mounting the CVX 600 [1-20](#)

in a Telco rack [1-21](#)

in an EIA rack [1-21](#)

locating the mounting holes [1-23](#)

radio frequency specifications [A-5](#)

redundant line termination modules (RLTMs),
 replacing [3-16](#)
regulatory compliance information [iii](#)
replacement hardware, ordering [3-44](#)

S

SCC-RLTM interface specifications [A-18](#), [A-19](#)
system control card (SCC)
 LEDs [2-44](#), [2-45](#), [2-46](#), [2-47](#)
 replacing the SCC-RLTM [3-16](#)
 replacing the SCC-SM [3-11](#)
 SCC-RLTM specifications [A-18](#)

T

T1 shielded cable specifications [A-13](#)
Telco rack hole spacing [1-21](#)
terminal server [2-39](#)
terminal, connecting to the CVX 1800 [2-33](#)

W

wrist strap, antistatic [3-2](#)



CVX 600 Multi-Service Access Switch

Hardware Installation Guide

*Nortel, Nortel Networks, the Nortel Networks corporate logo, the Globemark design, and CVX are trademarks of Nortel Networks. All other trademarks are the property of their owners.

© 2001 Nortel Networks. All rights reserved. Information in this document is subject to change without notice. Nortel Networks assumes no responsibility for any errors that may appear in this document.

Printed in the USA

296-1011-202
CVX Multi-Service Access Switch Release 5.0, Document Revision 02.01
August 2001

NORTEL
NETWORKS™

Free Manuals Download Website

<http://myh66.com>

<http://usermanuals.us>

<http://www.somanuals.com>

<http://www.4manuals.cc>

<http://www.manual-lib.com>

<http://www.404manual.com>

<http://www.luxmanual.com>

<http://aubethermostatmanual.com>

Golf course search by state

<http://golfingnear.com>

Email search by domain

<http://emailbydomain.com>

Auto manuals search

<http://auto.somanuals.com>

TV manuals search

<http://tv.somanuals.com>