

## 5" Outdoor Speaker

MODEL: ISA-449WH

For use with IMA4406, IM4406, IMA4006  
& IM4006 Series Radio/Intercom Systems

### LOCATION

1. Determine location for the speaker on outside of house – near patio, on porch, or other desired location.
2. Locate speaker at a convenient operating height – approximately 4½ feet above ground.

### WIRING (FRAME)

1. Refer to Figure 1. Run cable from master station to outdoor speaker location.
2. Run wiring through the hole in the mounting frame. Wrap cable around plastic projection under wiring access hole.

### MOUNTING (FRAME)

1. Refer to Figure 1. The mounting frame may be mounted directly to the exterior wall, or to a single-gang outlet box mounted in the wall.
2. Before attaching the mounting frame to wall, apply a continuous bead of caulk around the back edge of the frame.
3. Secure mounting frame to wall with two (2) N° 6 - 32 x 1¼" mounting screws.

### WIRING

Refer to Figure 2. Remove plastic clip that holds the rubber gasket to the printed circuit board.

Refer to Figure 3. As illustrated, connect wires from the master unit to the six (6) screw terminals. Red wire to the terminal marked red, red/white wire to the terminal marked red/white, etc.

Refer to Figure 4. Fold rubber gasket over installed wiring. Hold gasket tab to printed circuit board by folding tab over and sliding the removed plastic clip over tab and printed circuit board.

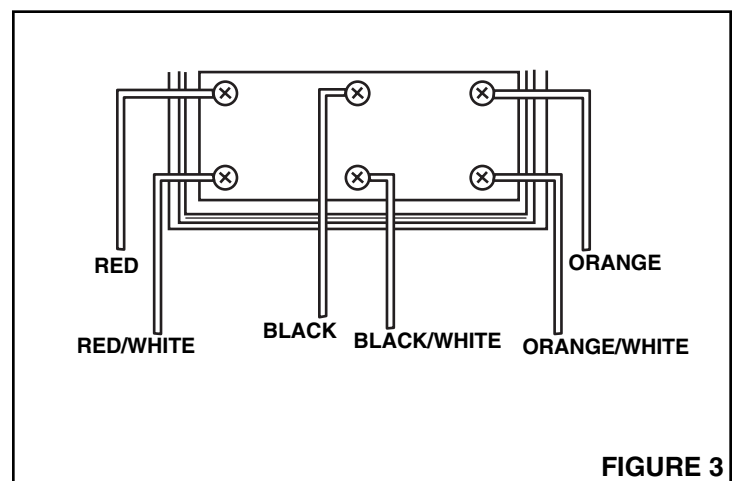
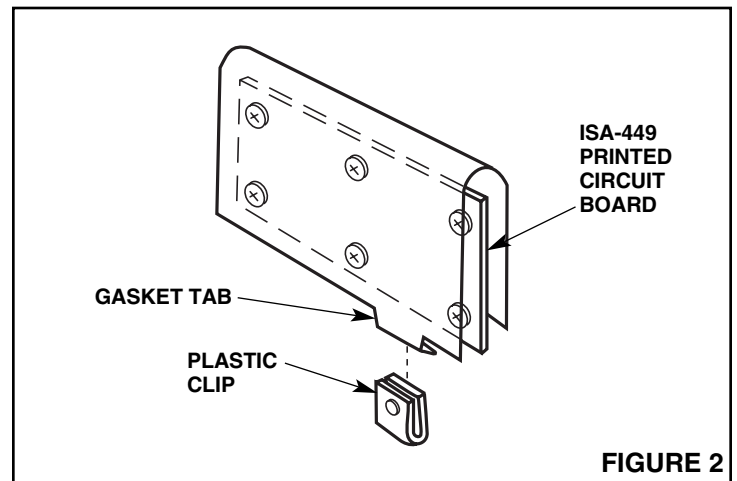
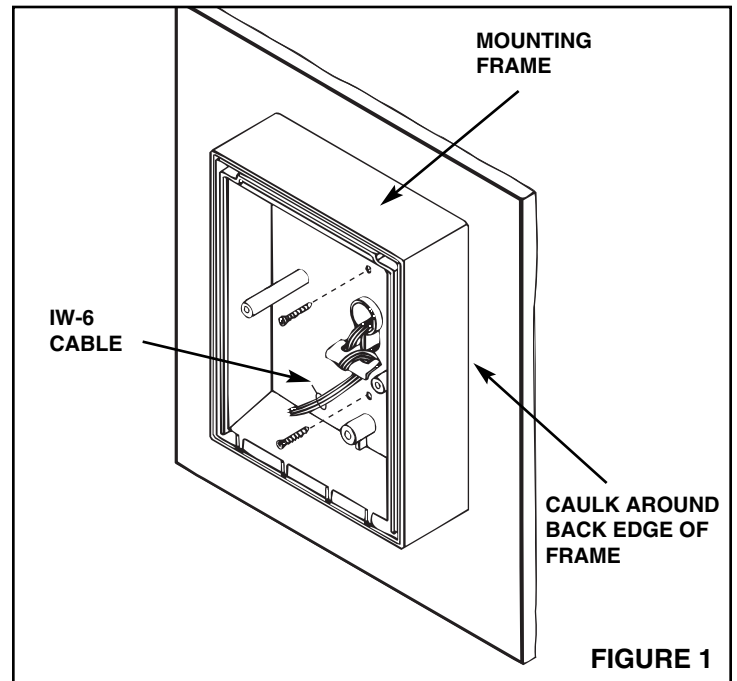

# MOUNTING

1. Refer to Figure 5. Carefully place excess wire into mounting frame.
2. Place gasket (furnished) into groove of mounting frame. The gasket will fit into both side and top grooves. The bottom of the frame where the weep slots are should not be filled with the gasket material.
3. Place edge of the outdoor speaker into groove of the mounting frame. Make sure the speaker and frame fit together tightly.
4. Secure speaker to frame with two (2) N° 8 x 2" mounting screws (furnished).

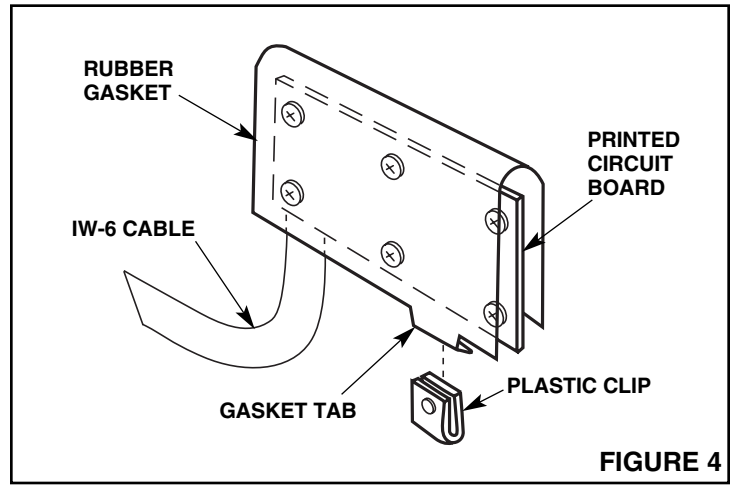

**IMPORTANT – WHEN NUTONE MODEL IW-6R WIRING IS USED:**

CONNECT TO SCREWS ON PRINTED CIRCUIT BOARD MARKED:

	ORN
	BLK
	BLK/WHITE
	ORN/WHITE
	RED
	RED/WHITE

BLUE STRIP

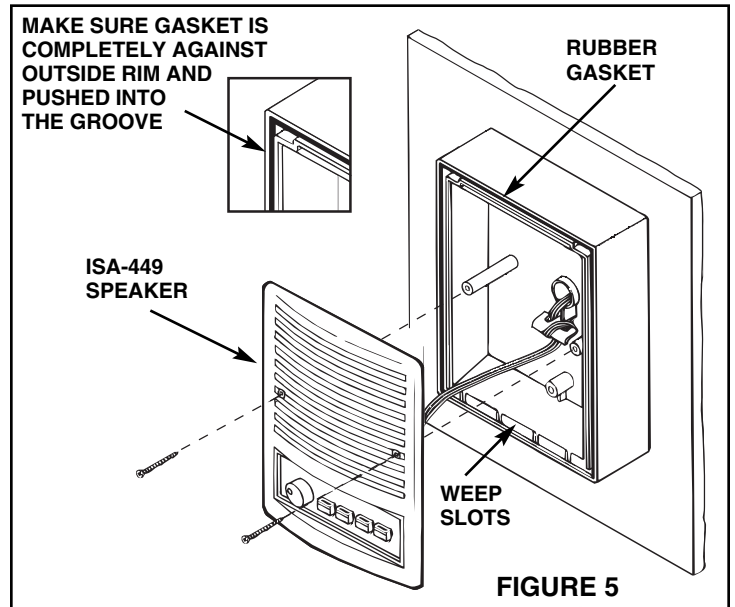

## NuTone®

### Two Year Limited Warranty

**WARRANTY OWNER:** NuTone warrants to the original consumer purchaser of its products that such products will be free from defects in materials or workmanship for a period of two (2) years from the date of original purchase. **THERE ARE NO OTHER WARRANTIES, EXPRESS OR IMPLIED, INCLUDING, BUT NOT LIMITED TO, IMPLIED WARRANTIES OF MERCHANTABILITY OR FITNESS FOR A PARTICULAR PURPOSE.**

**During this two year period,** NuTone will, at its option, repair or replace, without charge, any product or part which is found to be defective under normal use and service. **THIS WARRANTY DOES NOT EXTEND TO FLUORESCENT LAMP STARTERS OR TUBES, FILTERS, DUCT, ROOF CAPS, WALL CAPS AND OTHER ACCESSORIES FOR DUCTING.** This warranty does not cover (a) normal maintenance and service or (b) any products or parts which have been subject to misuse, negligence, accident, improper maintenance or repair (other than by NuTone), faulty installation or installation contrary to recommended installation instructions.

The duration of any implied warranty is limited to the two year period as specified for the express warranty. Some states do not allow limitation on how long an implied warranty lasts, so the above limitation may not apply to you.

**NUTONE'S OBLIGATION TO REPAIR OR REPLACE, AT NUTONE'S OPTION, SHALL BE THE PURCHASER'S SOLE AND EXCLUSIVE REMEDY UNDER THIS WARRANTY. NUTONE SHALL NOT BE LIABLE FOR INCIDENTAL, CONSEQUENTIAL OR SPECIAL DAMAGES ARISING OUT OF OR IN CONNECTION WITH PRODUCT USE OR PERFORMANCE.** Some states do not allow the exclusion or limitation of incidental or consequential damages, so the above limitation or exclusion may not apply to you. This warranty gives you specific legal rights, and you may also have other rights, which vary from state to state. This warranty supersedes all prior warranties.

**WARRANTY SERVICE:** To qualify for warranty service, you must (a) notify NuTone at the address stated below or telephone 1/800-543-8687, (b) give the model number and part identification and (c) describe the nature of any defect in the product or part. At the time of requesting warranty service, you must present evidence of the original purchase date.

---

Date of Installation \_\_\_\_\_ Builder or Installer \_\_\_\_\_

---

Model No. and Product Description \_\_\_\_\_

**IF YOU NEED ASSISTANCE OR SERVICE:**  
 For the location of your nearest NuTone Independent Authorized Service Center:  
**Residents of the contiguous United States** Dial Free 1-800-543-8687  
 Please be prepared to provide:  
 Product model number • Date and Proof of purchase • The nature of the difficulty

**Residents of Alaska or Hawaii should write to:** NuTone Inc. Attn: Department of National Field Service, 4820 Red Bank Road, Cincinnati Ohio 45227-1599.  
**Residents of Canada should write to:** Broan-NuTone Canada, 1140 Tristar Drive, Mississauga, Ontario, Canada L5T 1H9.

Rev. 01/2005

Product specifications subject to change without notice.  
 4820 Red Bank Road, Cincinnati, Ohio 45227  
 Printed in China, Rev. 08/06, Part No. 61428

## Free Manuals Download Website

<http://myh66.com>

<http://usermanuals.us>

<http://www.somanuals.com>

<http://www.4manuals.cc>

<http://www.manual-lib.com>

<http://www.404manual.com>

<http://www.luxmanual.com>

<http://aubethermostatmanual.com>

Golf course search by state

<http://golfingnear.com>

Email search by domain

<http://emailbydomain.com>

Auto manuals search

<http://auto.somanuals.com>

TV manuals search

<http://tv.somanuals.com>