

Numark®

CDN15/MPCD3

PROFESSIONAL CD PLAYERS

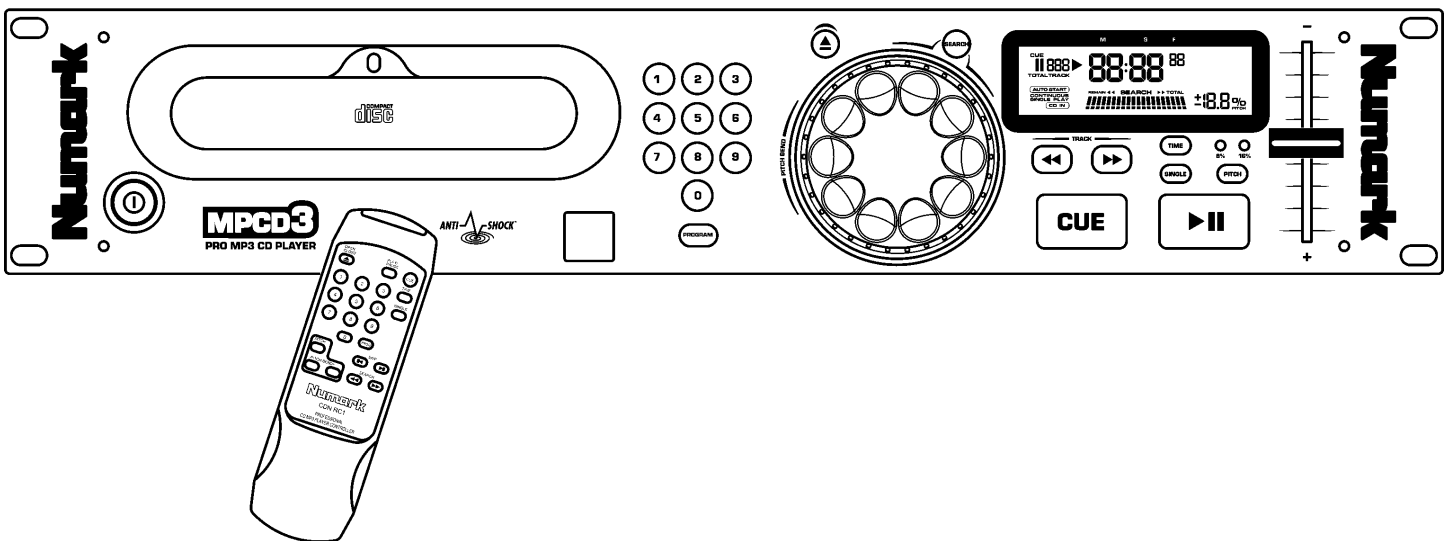
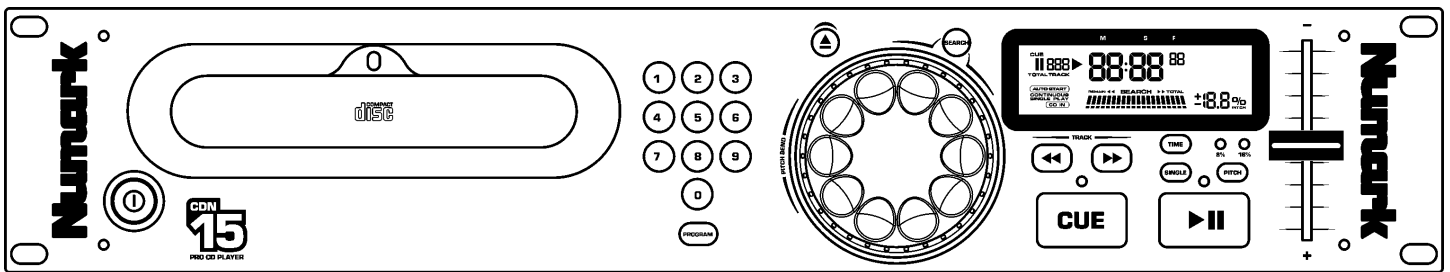

USER'S MANUAL

SAFETY INSTRUCTIONS

- a) Read Instructions - All the safety and operating instructions should be read before this product is connected and used.
- b) Retain Instructions - The safety and operating instructions should be kept for future reference.
- c) Heed Warnings - All warnings on this product and in these operating instructions should be followed.
- d) Follow Instructions - All operating and other instructions should be followed.
- e) Placement - place the unit in a clean dry location.
- f) Water and Moisture - This product should be kept away from direct contact with liquids. The apparatus shall not be exposed to dripping or splashing and that no objects filled with liquids, such as vases, shall be placed on the apparatus.
- g) Temperature - Avoid placing this product to close to any high heat sources such as radiators. Do not use this unit at temperatures below 41°F/5°C or higher than 95°F/35°C.
- h) Ventilation - The appliance should be situated so that its location or position does not interfere with its proper ventilation. For example, the appliance should not be situated on a bed, sofa, rug, or similar surface that may block the ventilation opening; or, placed in a built-installation, such as bookcase or cabinet that may impede the flow of air through the ventilation openings.
- i) Power Sources - This product should be connected to a power supply only of the type described in these operating instructions, or as marked on the unit.
- j) Power Cord Protection - Power supply cords should be routed so that they are not likely to be walked upon or pinched by items placed on or against them. When removing the cord from a power outlet be sure to remove it by holding the plug attachment and not by pulling on the cord.
- k) Object and Liquid Entry - Take care that objects do not fall into and that liquids are not spilled into the inside of the mixer.
- l) Cleaning - The appliance should be cleaned only as recommended by the manufacturer. Do not use chemical solvents to clean the unit.
- m) Non-use Periods - The power cord of the appliance should be unplugged from the outlet when left unused for long periods of time.
- n) Damage Requiring Service - Only qualified personnel should service this product. If you have any questions about service please contact Numark at the number(s) shown on the back cover of this manual.
- o) Grounding or Polarization - Precautions should be taken so that the grounding or polarization means built into the CD player is not defeated.
- p) Internal/External Voltage Selectors - Internal or external voltage selector switches, if any, should only be reset and re-equipped with a proper plug for alternative voltage by a qualified service technician. Do not attempt to alter this yourself.
- q) Carts and Stands - The appliance should be used only with a cart or stand that is recommended by the manufacturer of the cart or stand. An appliance and cart combination should be moved with care. Quick stops, excessive force, and uneven surfaces may cause the appliance and cart combination to overturn.



CAUTION
RISK OF ELECTRIC SHOCK
DO NOT OPEN



CAUTION: TO REDUCE THE RISK OF ELECTRIC SHOCK DO NOT REMOVE ANY COVER. NO USER-SERVICEABLE PARTS INSIDE. REFER SERVICING TO QUALIFIED SERVICE PERSONNEL ONLY.

The lightning flash with arrowhead symbol within the equilateral triangle is intended to alert the user to the presence of un-insulated "dangerous voltage" within the product's enclosure that may be of sufficient magnitude to constitute a risk of electric shock.

The exclamation point within the equilateral triangle is intended to alert the user to the presence of important operating and maintenance (servicing) instructions in the literature accompanying this appliance.

CAUTION
FOR USA & CANADIAN MODELS ONLY
TO PREVENT ELECTRIC SHOCK DO NOT USE THIS (POLARIZED) PLUG WITH AN EXTENSION CORD, RECEPTACLE OR OTHER OUTLET UNLESS THE BLADES CAN BE FULLY INSERTED TO PREVENT BLADE EXPOSURE.

WARNING: To reduce the risk of fire or electrical shock, do not expose this appliance to rain or moisture. Electrical equipment should NEVER be kept or stored in damp environments.

NOTICE CONCERNING FCC REGULATIONS

This equipment generates and uses radio frequency energy and may cause interference to radio and television reception if you do not operate it in strict accordance with the procedures detailed in this OPERATING MANUAL. This unit complies with Class B computing device rules in accordance with the specifications in Sub-part J or Part 15 of the FCC Rules, which are designed to provide reasonable protection against such interference in a residential installation. There is no guarantee, however, that interference will not occur in a particular installation. If the unit does cause interference to any radio or television reception, try to reduce it by one or more of the following means:

- a) Reposition the other unit and/or its antennae
- b) Move this unit
- c) Move this unit and the other unit(s) further apart
- d) Plug this unit into a different AC outlet so that it is on a different circuit from the other equipment.

This note is in accordance with Section 15.838 of the FCC Rules.

This unit does not exceed the Class B limits for radio noise emission from digital apparatus set out in the radio interference regulations of the Canadian Department of Communications.

SERVICE INSTRUCTIONS

- Disconnect power cord before servicing
- Replace critical components only with factory parts or recommended equivalents
- For AC line powered units - Before returning repaired unit to user, use an ohmmeter to measure from both AC plug blades to all exposed metallic parts. The resistance should be no more than 100,000ohms.

DANGER: INVISIBLE LASER RADIATION WHEN OPEN AND INTERLOCK FAILED OR DEFEATED. AVOID DIRECT EXPOSURE TO BEAM.

USE OF CONTROLS OR ADJUSTMENTS OTHER THAN THOSE SPECIFIED HEREIN MAY RESULT IN HAZARDOUS RADIATION EXPOSURE

DOUBLE INSULATED - When servicing use only identical replacement parts

For 220-volt use in USA, use NEMA style 220-volt plug. For other countries use proper plug for local outlet.

Numark- The Leader in DJ Technology

Numark[®] CDN15/MPCD3

PROFESSIONAL CD PLAYERS

CONGRATULATIONS...

You have just purchased a CD player designed specifically for the professional DJ. This unit has been designed to provide CD mixing with the same ease and creativity that you have enjoyed with records. Please take a few moments to familiarize yourself with your CD Player by reading the following information before attempting to operate the unit.

Once again, congratulations and thank you for making Numark your choice in professional CD players.

FEATURES:

- Interactive pitch wheel adjustment
- Rubber buttons
- Direct Track Access
- Frame search
- Track Sequence Programming
- Sleep mode
- Rapid wheel search
- Auto cue
- Pitch display
- CDR compatible

MPCD3 only

- MP3 Playback from CDR
- Infrared Remote Control
- Buffered Anti-Shock™ Memory
- Digital Output
- Remote Start
- Relay Start

CHECK TO BE SURE THE FOLLOWING ITEMS ARE IN THIS BOX:

CD PLAYER UNIT
IEC POWER CORD
OWNERS MANUAL (THIS BOOKLET)
RCA CONNECTING CABLES

MPCD3 ONLY:
INFRARED REMOTE CONTROL

Please record the serial number of your unit as shown on the back of the chassis as well as the name of the dealer from whom you purchased the unit. Retain this information and your original purchase receipt for your records. Please return the enclosed warranty card to register your CD player with us.

MODEL: _____ PURCHASED FROM: _____

SERIAL NUMBER: _____ DATE OF PURCHASE: _____

Numark - The Leader in DJ Technology

TABLE OF CONTENTS

Safety Instructions	2
Introduction and Registration	3
Set-up & Connections	5
Description of the Features	
Face Panel	6
Rear Panel	8
Display	9
MP3 Audio Information	10
Basic Operation	
Play, Pause and Cue Operations	11
Matching the Tempo	12
Beat Matching Using Pitch Bend	12
Example of Mixing	13
Before Switching off the Power	14
Troubleshooting Guide	14
Information and Specifications	15
Warranty	16

SETUP and CONNECTIONS

Typical connection with a mixer is illustrated below.

1. Mount the units in your console or rack with 19" EIA rails.
2. The CD Player should be mounted not to exceed an angle of 15 degrees.
3. Your CD player can be affected by excess vibration so mount the units in a secure environment if possible.
4. Connect the line output connections using the supplied audio cable from the CD Player to the line inputs of your mixer.
5. Connect IEC power cord to appropriate power source.
6. (MPCD3 only) Connect Fader start cable. Attach your CD play to a similarly equipped DJ mixer.
(This cable is a standard 1/8" mono – 1/8" mono cable obtainable from you local music or electronics store)
7. (MPCD3 only) If setting up 2 units, you can connect a relay cable between the units.
(This cable is a standard 1/8" mono – 1/8" mono cable obtainable from you local music or electronics store)

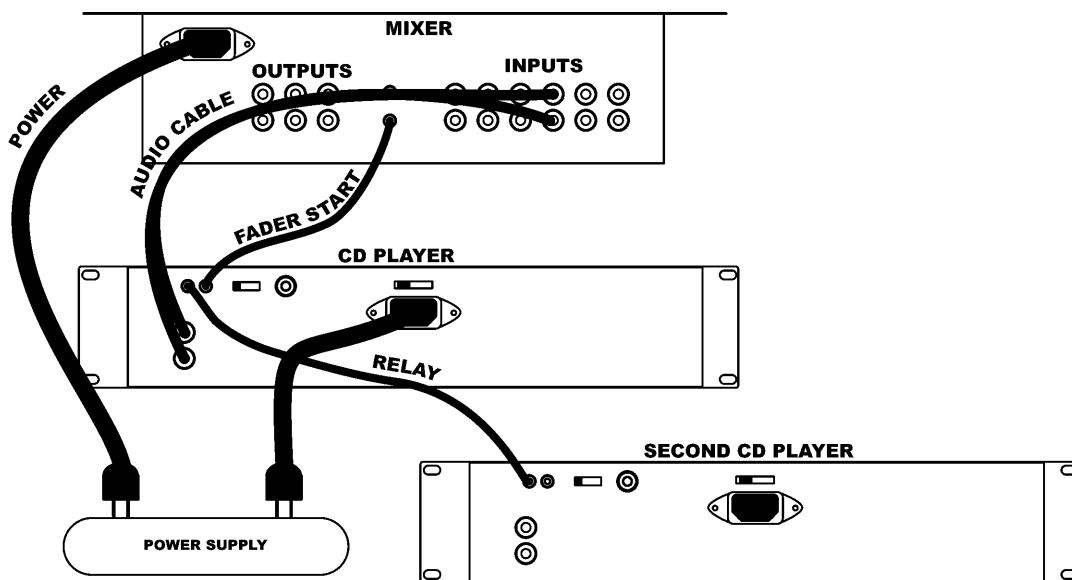
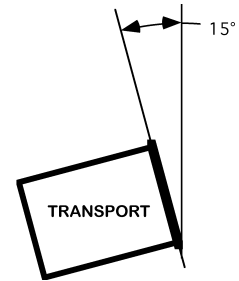

<p>LINE VOLTAGE SELECTION</p> <p>1) The desired voltage may be set with the VOLTAGE SELECTOR switch on the rear panel of the unit.</p> <p>2) Do not move the VOLTAGE SELECTOR switch with excessive force as this may cause damage.</p> <p>3) If the VOLTAGE SELECTOR switch does not move smoothly contact a qualified serviceman.</p>	<p>115V</p> <p>230V</p>
--	-------------------------

<p>DIGITAL OUTPUTS: This CD player is specially equipped with digital outputs. The format is type 2, form 1, also known as S/PDIF (Sony/Phillips Digital Interface Format). When the digital output is used the variable pitch slider and pitch bend buttons or pitch wheel should not be used.</p> <p>Note: If digital information is allowed to change in pitch, other devices may not read the digital output properly.</p>
--

FRONT PANEL FEATURES

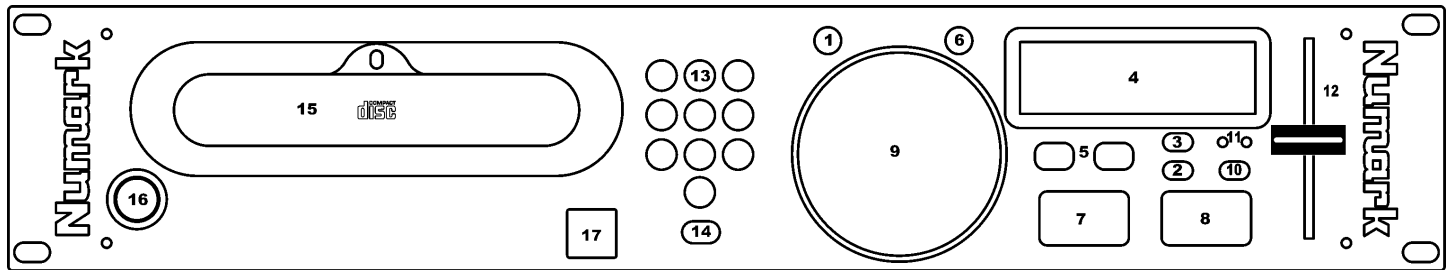

1. **Open/Close:** Press to load or eject the disc. The tray will not open if a disc is in play. The tray door will automatic close in 30 seconds if left open. This is to protect the tray from accidental damage while open
2. **Single:** toggles the unit to play back just one track at a time (single) or play continuously through all tracks and then start over repeating the CD infinitely (continuous).
3. **Time:** switches the time modes on the display between elapsed playing time, remaining time on the track, and remaining time on the total CD. When toggled to remaining time total the total number of remaining tracks will also show.
4. **LCD Display :** Indicates all the functions, as they are occurring, with the CD.
5. **Track Buttons:** These buttons are used to select the track to be played.
6. **Search Button:** Pressing this button allows you to use the wheel and rapidly scan the music to find a cue point. The search function automatically shuts off after 8 seconds of non-use or you may toggle it off.
7. **Cue:** Returns and pauses the music at the last set cue point. The cue point is where the music will begin when play is pressed. The cue point is set as the initial start point on a track or can be moved when play is started at a different point. For instance if the music is paused then play is pressed a new cue point is set. You can easily edit the cue point by turning the wheel during pause. As you rotate the wheel the music will sound. By stopping the wheel and pressing play a new point is set. Alternately pressing the PLAY button and the CUE button allows the CD to be played from the same position any number of times.

Note: Pressing cue 2 times plays music temporarily from this point until the button is released.

8. **Play/Pause:** Starts the music from the cue point or pauses it while in play. By pressing play after pause a new cue point will be set
9. **Jog Wheel:**

Cue Function: As explained under "CUE", when the music is paused and you rotate the wheel, music will sound. By pressing play a new cue point is set.

Search Function: As explained under "SEARCH BUTTON", when search is press and you rotate the wheel, the music will rapidly scan the music to find a cue point.

Pitch Bend Function: allows the user to temporarily change the speed of the music to align beats. When the beats of the music of the CD you wish to match is fast compared to the tempo of the other music rotate the jog wheel counter clockwise (to the left). When the CD is behind rotate the jog wheel clockwise (to the right). The pitch changes temporarily while the jog wheel is rotated. The faster you rotate the wheel the more pitch is changed. Releasing the wheel results in a return to the original pitch.

Numark- The Leader in DJ Technology

- 10. Pitch Range:** activates the pitch slider and adjusts the amount of control the pitch slider has on the overall speed of music. Tapping the pitch will toggle slider between 8% and 16% pitch ranges. Holding the pitch for 3 seconds will deactivate the pitch control.
- 11. Pitch Range LEDs:** indicate current pitch range. When both LEDs are off the pitch slider is not active
- 12. Pitch Slider:** By moving the slider in the (+) direction the speed of the music permanently speeds up. By moving the slider in the (-) direction the speed of the music permanently slows down. To match the speeds of two CDs you can adjust the pitch. When the tempo of the music of the CD you wish to match is slow compared to the tempo of the other music, move the slider to the (+) side and match the speed. When faster, move the pitch slider to the (-) side. By making this adjustment the speeds will be matched though the beats may not yet be aligned.
- 13. Track Buttons:** These buttons are used to select the track to be played.
- 14. Program:**
- Press program, the unit will stop and the program indicator will light
 - Select the track to be programmed
 - Press the PROGRAM button
 - Select another track to be programmed
 - Press the PROGRAM button
 - Press Play

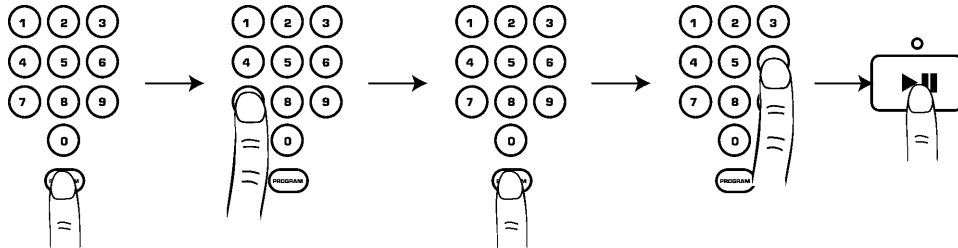

You can program up to 30 tracks. Press PLAY to start the program. To exit and erase program hold the program button down for more than 2 seconds while the unit is stopped, open the disc tray, or turn off the power.

- 15. CD Drawer:** Place your CDs you wish to play in here. This unit is designed to play commercially available CD and properly burned and finalized CDR and CDRW formats. Due to variances on the specification of certain CD burners and CDs some discs home made CDs may not play properly.
- 16. Power Switch:** Turn on and turn off the machine with this button. The unit should always be shut down with this button first before any external power is removed.
- 17. Infrared Remote Receiver (MPCD3 only):** Used with wireless remote control to adjust functions of the unit. Should be kept clear of objects that might block the infrared beam of the remote control.

REAR PANEL FEATURES

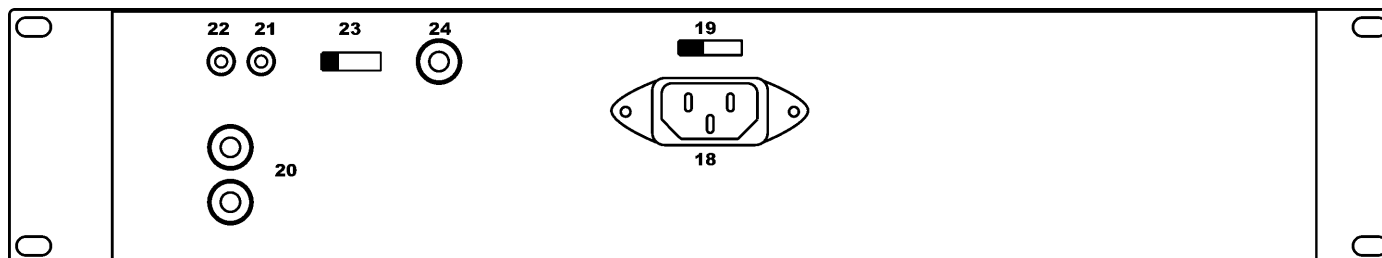

18. IEC Power Plug Connector: Plug your supplied power cord in here.

19. Voltage Selector: Set this switch to the voltage for your location.

20. RCA Audio Connectors: Connect your CD player to your mixer from this line level output.

21. Relay Connector (MPCD3 only): To use connect a relay cable between two units as described in the setup section of this manual.

- Insert CDs into both sides of the unit.
- Hold down the “single” button for 3 seconds until the display indicates “auto-start”. Both units must be active for relay to work.
- Put both units in SINGLE play mode while learning this function.
- Press play on the first unit. When that unit has finished play it will send a signal to the second to start play. You will see the first unit start play and second pause and cue to the beginning of the next track.

Note: The play command is sent at the end of specified play. If the unit is in SINGLE mode the play command will start at the end of the track. If the unit is in CONTINUOUS mode the play command will be sent at the end of the full CD. Two CDs will play continuously, alternating from side to side.

22. Remote Start Connector: Use this connector to plug into your fader start compatible mixer or remote switch as described in the setup section of this manual. This function is always active. To use this connector for fader start, connect a fader start cable to a fader start compatible mixer. Every time you move the crossfader on the mixer over to the side that the unit is on, it will automatically start playing. When you move the fader away from that side, the unit will stop. Moving the fader *back* to the unit side will start play again.

There are two potential modes associated with the switch PLAY-CUE and PLAY/PAUSE. The factory setting is PLAY-CUE mode. This means that when the unit is remotely stopped it will go back to the cue point automatically. To change modes hold down the “time” button for 3 seconds and the display will flash the play “▶” and pause “||” icons. In PLAY/PAUSE mode, moving the crossfader away from the unit side pauses right where it is, and resumes when the fader is brought back to the unit. To change modes back to PLAY-CUE hold down the “time” button for 3 seconds and the display will flash the play “▶” and cue “**CUE**” icons in the display.

23. Remote Assignment Switch: Set this switch in the position for the method of remote start you will be using. Foot switches are often used for creative mixing techniques and can be found in most music shops. Connector plugs are often ¼” and an adapter to 1/8” will be needed for connection. There are also two types of footswitches that will work with this connector. The first is a typical, on/off pushbutton switch and are generally used for switching channels on guitar amps. The second switch is a momentary footswitch and is usually used for keyboard sustain pedals. If you are unsure of the style of switch you have, try each position until it works as desired.

- **ON-OFF** – for use with an ON-OFF switch.
- **MOMENTARY** – for use with a momentary style of switch.
- **MIXER** – for use with a fader start compatible DJ mixer

24. Digital Output: The format is type 2, form 1, also known as S/PDIF (Sony/Phillips Digital Interface Format). In order to use the digital output you should not use variable pitch slider and the pitch bend buttons. *If you adjust the pitch, other devices may not read the digital output properly because the sampling rate changes.*

DISPLAY FEATURES

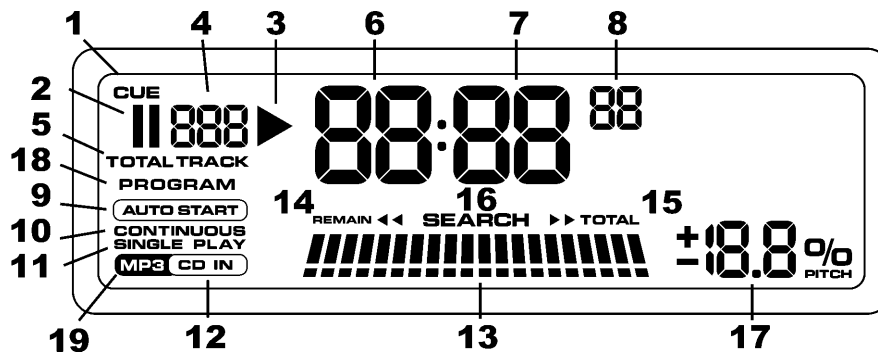

1. **CUE:** Flashing when the unit is setting a cue point. Lit continuously when the unit is paused at a cue point.
2. **PAUSE (II):** Active when the unit is paused.
3. **PLAY (>):** Active while the unit is actually playing a CD.
4. **TRACK:** Shows the track that the unit is playing.
5. **TOTAL:** indicates when total CD remaining tracks are displayed.
6. **MINUTES:** Shows the minutes elapsed or remaining depending on mode setting.
7. **SECONDS:** Shows the seconds elapsed or remaining depending on mode setting.
8. **FRAMES:** The CD Player breaks down a second into 75 frames for accurate cueing. This shows the frames elapsed or remaining depending on mode setting.
9. **AUTOSTART:** will light when the unit is set to relay from CD unit to CD unit.
10. **CONTINUOUS PLAY:** Shows when the unit is set to play back the entire CD without stopping between tracks.
11. **SINGLE PLAY:** Shows when the unit is set to play just one track at a time.
12. **CD IN:** indicates a CD is in the unit.
13. **TIME BAR:** Shows either track elapsed time, remaining track time, or remaining total time depending on the setting of the "time" button.

TIME MODE:

 14. **REMAIN** indicates when track remain time is displayed.
 15. **TOTAL** indicates when total CD remain time is displayed.

note: both indications will not be lit when the unit is showing "elapsed" time
16. **SEARCH:** indicates when the unit is searching through the music.
17. **PITCH DISPLAY:** indicating current pitch.
18. **PROGRAM:** Indicates when a track sequence has been programmed in the memory.
19. **MP3 (MPCD3 only):** Indicates when an MP3 CD is in the drawer.

MP3 AUDIO (MPCD3 only)

While playing MP3 music, please note the following points.

It is assumed that the user of this unit understands how to properly burn a CDR and add MP3 files to it. Many different variations MP3 audio are available from various sources and computer programs. Please read the following to better understand how your unit will work with MP3 files.

1. Playback of VBR (variable bit rate) MP3 files is not possible on this unit. Only standard CBR (constant bit rate) files may be played.
2. The time display for the MP3 files may not be precise due to the inherent nature of compressed audio.
3. Cue points can not be set on MP3 audio. When MP3 files are played and "CUE" is pressed the music will return to the beginning of the track and pause. MP3 audio lacks the time code feature of regular CD Audio that allows for cue point setting.
4. Track sorting conforms to ISO9660 standards, but not all programs in conformity with this standard. The playing order may be different with the burning order. Folders will be sorted first followed by the tracks within similar to a computer system alphabetical file sort.

For example, The disc is burned with following tracks.

1ab, 2bc, 3cd, 4de, 10jk, 11kl, 20mn, 31no

Due to different burning program formats, the playing order is different as below.

- Conformable to ISO9660, the playing order is
1ab -> 2bc -> 3cd -> 4de -> 10jk -> 11kl -> 20mn -> 31no
 - Unconformable to ISO9660
1ab -> 10jk -> 11kl -> 20mn -> 2bc -> 31no -> 3cd -> 4de
5. If the ID3 (data area) in your MP3 includes photos, then you may not be able to play the track.
 6. If the over-sampling frequency of the MP3 music is not 44.1KHz, then the PITCH CONTROL will not work.
 7. If the disc is burned with both MP3 and CDDA (Digital Audio) music, then it will be recognized according to the first track. For example, if the first track is CDDA music the unit will play CDDA music only.

DESCRIPTION OF THE PLAY/PAUSE AND CUE OPERATIONS

PLAY and CUE

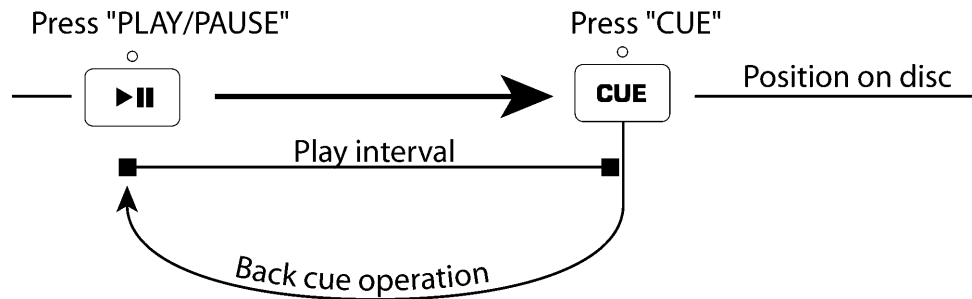

Pressing the "PLAY/PAUSE" button starts the disc. Pressing the "CUE" button will reset the disc to the last place where the disc was started. This is called the cue point. By alternately pressing the "PLAY/PAUSE" button and the "CUE" button, the disc may be returned and played from the cue point any number of times. This function is called back cue.

PLAY, PAUSE and CUE

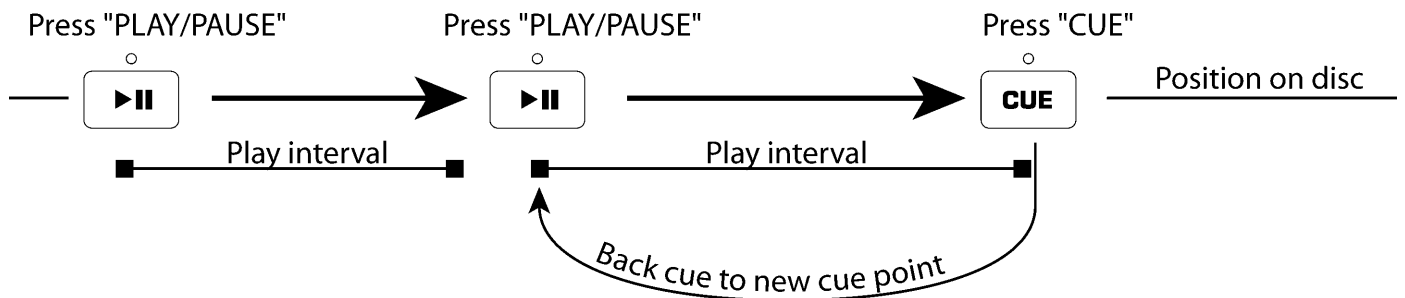

When Play is paused and then started again, the return position for the back cue will be updated as the new cue point

EDITING CUE POINT

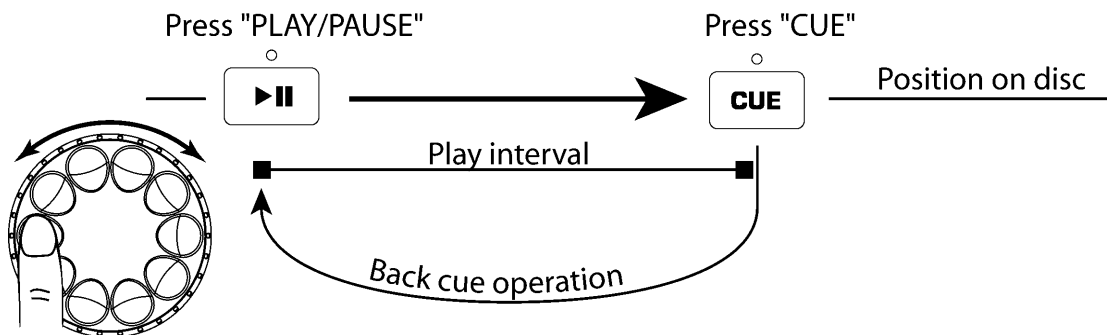

When the jog wheel is turned while a cue point is set, a new cue point can be located. The CD player will repeatedly play small parts of the CD as you move it to the desired position. By pressing "PLAY/PAUSE" then "CUE" you can confirm that this new cue point is desirable.

MATCHING THE BEATS PER MINUTE (BPM)

Match the tempo by monitoring the music of two CD Players by ear and adjusting the pitch. When the tempo of the music of the selected CD player is slow compared to the tempo of the other player, move the slider to the “+” side and match the tempo. When faster, move the pitch slider to the “-” side. The following description is for the case of matching the pitch of PLAYER 2 to the pitch of the music being played on PLAYER 1.

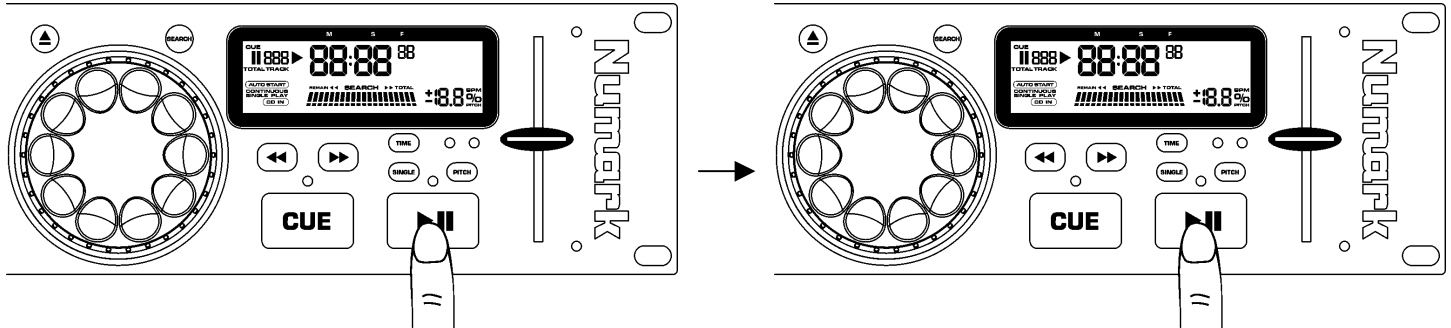

Press PLAY/PAUSE to start PLAYER 1
PLAYER 1 is playing

Press PLAY/PAUSE to start PLAYER 2
Both CD players are playing discs.
Listen to PLAYER 2 in your headphones

When PLAYER 2 is slow compared to PLAYER 1 speed up PLAYER 2

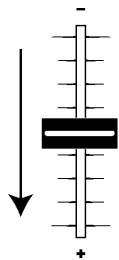

When PLAYER 2 is fast compared to PLAYER 1 slow down PLAYER 2

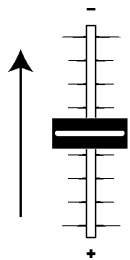

MATCHING BEATS USING PITCH BEND

If you find the BPM's (Beats Per Minute or Tempos) are the same, however, the drumbeats are not matched you will need to temporarily change the pitch. This description is for the case of matching the beat of PLAYER 2 to the beat of the music being played on PLAYER 1. (This procedure can be done on either PLAYER).

After matching the BPM's adjust the pitch temporarily as follows:

When PLAYER 2 is behind rotate the jog wheel clockwise to bend pitch faster

When PLAYER 2 is ahead rotate the jog wheel counter clockwise to bend pitch slower.

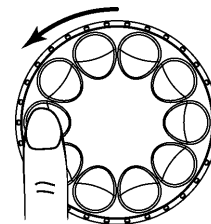
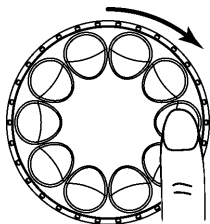

The pitch changes automatically while the jog wheel is rotated. The faster you rotate the wheel the more you change. Releasing the wheel results in a return to the original pitch. (So the BPM's are once again the same)

EXAMPLE OF MIXING USING TWO CD PLAYERS

While playing a disc on PLAYER 1 load a disc into PLAYER 2 and select your next track, match its pitch to the track playing on PLAYER1 and when you are ready use the crossfader on your mixer to fade from PLAYER 1 to PLAYER 2.

Load a disc in PLAYER 1 and select the track and press PLAY.

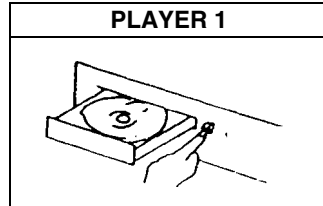

Load a disc and press the OPEN/CLOSE button.

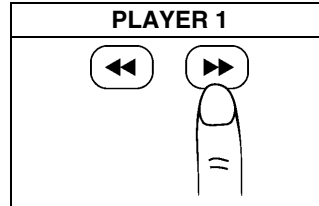

Select the track to be played.

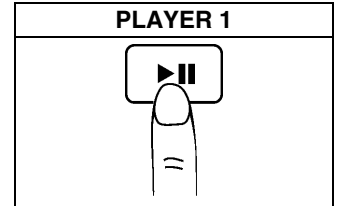

Press the PLAY button

Load a disc in PLAYER 2 and select the track then play.

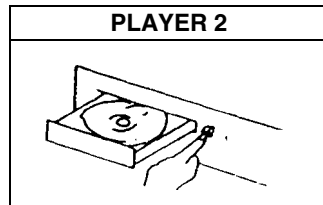

Load a disc and press the OPEN/CLOSE button.

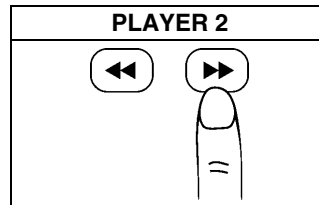

Select the track to be played.

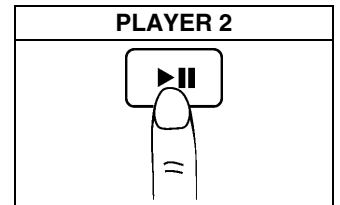

Press the PLAY button

Set and edit a start cue point on PLAYER 2

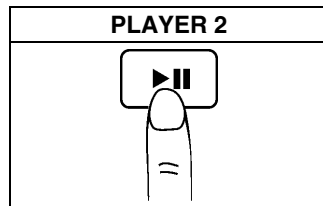

Press the Pause button of PLAYER 2.

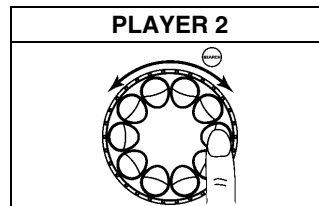

Press search and rotate wheel to rapidly look for a cue point.

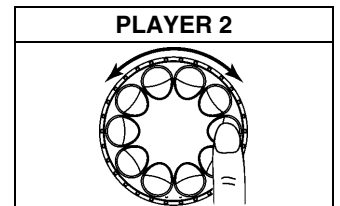

Press search to release. Slowly set the right cue point using the jog wheel.

Check you new cue point

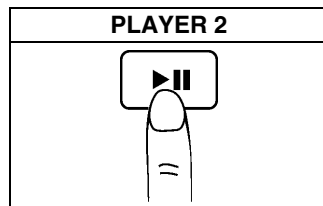

Listen with the monitor and press the play button.

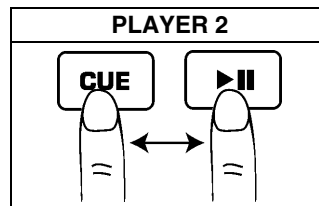

Press the cue button then play to be sure of the set cue point.

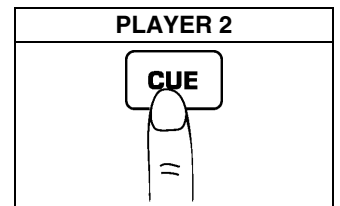

Set the player to the Cue point by pressing Cue

Do a MIX!

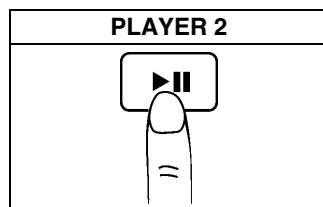

With a matching downbeat from Player 1 press the play button.

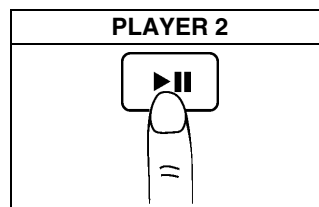

If you are beat mixing turn on your Pitch adjust and follow the directions for beat matching.

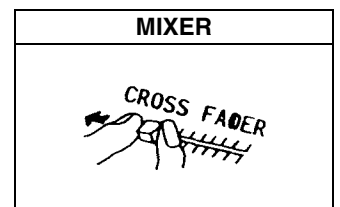

When you are happy with you mix adjust you mixer accordingly.

Numark - The Leader in DJ Technology

BEFORE SWITCHING OFF THE POWER:

When you have finished using the CD player, be sure that the disc tray is closed with the "OPEN/CLOSE" button before switching off the power.

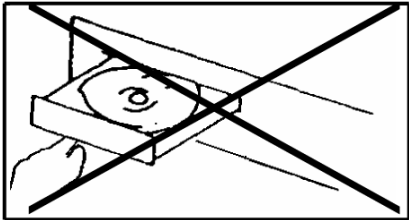

DO NOT switch off the power when the disc holder is open.

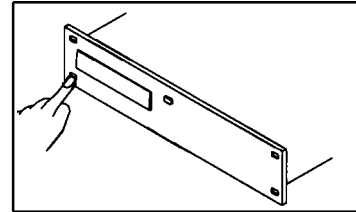

Switch off the power **after** the disc holder has been closed with the "OPEN/CLOSE" button

TROUBLESHOOTING:

Symptom	Possible Cause	Corrective Action
The power fails to switch on when the POWER switch is set to on	Poor power plug connection at the AC outlet or IEC Power cord loose from rear of unit	Insert the power plug firmly into the AC outlet and make sure connection is good in unit rear
Disc play does not start	The disc is loaded upside down The disc is too dirty	Reload the disc with the label side up Clean the disc
No sound	Improper output cable connections Improper amplifier operation	Connect the output cables correctly Check amplifier setup
Sound skips	The CD player is subject to vibrations or physical shock The disc is too dirty	Change the installation location Clean the disc
Hum	Loose cable connections	Firmly connect all audio plugs

SPECIFICATIONS

TECHNICAL

Disc Type:	Standard Compact discs (12 cm & 8 cm)
Time Display:	Track Elapsed, Track Remain, or Total Remain
Quantization:	1 bit linear/Channel, 3 Beam Laser
Oversampling rate:	8 Times
Sampling Frequency:	44.1 kHz
Frequency response:	20 Hz to 20 kHz
T.H.D. + NOISE:	Less Than 0.005%
S/N ratio (IHF-A):	> 90 dB
Dynamic range:	> 90 dB
Output level:	2 Volts R.M.S.
Start Time:	within 0.015-0.03 seconds
Start Time (MPCD3):	within 0.015 seconds
Pitch control range:	+/- 8, 16% slider
Pitch bend:	± 16%
Digital Output (MPCD3):	type 2, form 1, S/PDIF (Sony/Phillips Digital Interface Format)

GENERAL

Dimensions:	18.98" x 3.48" x 10.11" (482 x 88.5 x 257mm)
Weight:	18.04 lbs. (8.2 kg)
Power Supply:	115/230V AC, 50/60Hz
Power Consumption:	20W

* Specifications are subject to change due to ongoing improvements

Numark[®]

Professional Disc Jockey Products

LIMITED PRODUCT WARRANTY

1. What is covered and for how long? NUMARK INDUSTRIES LCC ("NUMARK") warrants to the original purchaser that NUMARK'S DJ Mixers, Amplifiers, CD players, turntables, preamplifiers, beatkeepers, equalizers, microphones, headphones, and all other accessories are free from defects in material and workmanship under normal use and service for the period commencing upon the date of purchase from an authorized NUMARK dealer and continuing for the following period of time after that date for **(1) Year**.
2. What is not covered? This Limited Warranty is conditioned upon proper use of the product by the purchaser. This Limited Warranty does not cover: (a) defects or damage resulting from accident, misuse, abuse, neglect, unusual physical or electrical stress, modification of any part of the product, or cosmetic damage; (b) equipment that has the serial number removed or made illegible; (c) all plastic surfaces and other externally exposed parts that are scratched or damaged due to normal use; (d) defects or damage from improper testing, operation, maintenance, installation, adjustment, or service of the mixers; (e) crossfaders.
3. What are NUMARK'S obligations? During the applicable warranty period, NUMARK will repair or replace, at NUMARK'S sole discretion, without charge to the purchaser, any defective component part of the mixer. To obtain service under this Limited Warranty, purchaser must first contact NUMARK and obtain a return authorization number ("RA#"). Purchaser must then return the mixer to NUMARK in an adequate container for shipping, accompanied by purchaser's sales receipt or comparable proof of sale showing the date of purchase, the serial number of the product, and the seller's name and address. To obtain an RA# and assistance on where to return the mixer, contact NUMARK customer service at 401-295 9000. Upon receipt, NUMARK will repair or replace the defective products. NUMARK may, at NUMARK'S sole discretion, use rebuilt, reconditioned, or new parts or components when repairing any product or replace a product with a rebuilt, reconditioned or new product. Repaired mixers will be warranted for a period equal to the remainder of the original Limited Warranty on the original mixer or for (90) days, whichever is longer. All replaced parts, components, boards and equipment become the property of NUMARK. If NUMARK determines that any mixer is not covered by this Limited Warranty, purchaser must pay all parts, shipping, and labor charges for the repair or return of such mixer.
4. What are the limits on NUMARK'S liabilities? THE WARRANTIES GIVEN IN THIS LIMITED WARRANTY, TOGETHER WITH ANY IMPLIED WARRANTIES COVERING NUMARK MIXERS, INCLUDING WITHOUT LIMITATION ANY WARRANTIES OF MERCHANTABILITY OR FITNESS FOR A PARTICULAR PURPOSE, ARE LIMITED TO THE DURATION OF THIS LIMITED WARRANTY. EXCEPT TO THE EXTENT PROHIBITED BY APPLICABLE LAW, NUMARK SHALL NOT BE LIABLE FOR ANY SPECIAL, INCIDENTAL, CONSEQUENTIAL, INDIRECT OR SIMILAR DAMAGES, LOSS OF PROFITS, DAMAGES TO PURCHASER'S PROPERTY, OR INJURY TO PURCHASER OR OTHERS ARISING OUT OF THE USE, MISUSE OR INABILITY TO USE ANY NUMARK MIXER, BREACH OF WARRANTY, OR NEGLIGENCE, INCLUDING BUT NOT LIMITED TO NUMARK'S OWN NEGLIGENCE, EVEN IF NUMARK OR ITS AGENT HAS BEEN ADVISED OF SUCH DAMAGES, OR FOR ANY CLAIM BROUGHT AGAINST PURCHASER BY ANY OTHER PARTY. THIS LIMITED WARRANTY IS THE COMPLETE WARRANTY FOR NUMARK'S MIXERS, AND IS GIVEN IN LIEU OF ALL OTHER EXPRESS WARRANTIES. THIS LIMITED WARRANTY SHALL NOT EXTEND TO ANYONE OTHER THAN THE ORIGINAL PURCHASER OF THIS PRODUCT AND STATES PURCHASER'S EXCLUSIVE REMEDY. IF ANY PORTION OF THIS LIMITED WARRANTY IS ILLEGAL OR UNENFORCEABLE BY REASON OF ANY LAW, SUCH PARTIAL ILLEGALITY OR UNENFORCEABILITY SHALL NOT AFFECT THE ENFORCEABILITY OF THE REMAINDER OF THIS LIMITED WARRANTY WHICH PURCHASER ACKNOWLEDGES IS AND WILL ALWAYS BE CONSTRUED TO BE LIMITED BY ITS TERMS OR AS LIMITED AS THE LAW PERMITS. This Limited Warranty allocates risk of product failure between purchaser and NUMARK, and NUMARK'S product pricing reflects this allocation of risk and the limitations of liability contained in this Limited Warranty. The agents, employees, distributors, and dealers of NUMARK are not authorized to make modifications to this Limited Warranty, or make additional warranties binding on NUMARK. Accordingly, additional statements such as dealer advertising or presentation, whether oral or written, do not constitute warranties by NUMARK and should not be relied upon.
5. How does state law apply to this warranty? SOME STATES DO NOT ALLOW THE EXCLUSION OR LIMITATIONS OF INCIDENTAL OR CONSEQUENTIAL DAMAGES OR HOW LONG AN IMPLIED WARRANTY LASTS, SO THE ABOVE LIMITATIONS OR EXCLUSIONS MAY NOT APPLY TO PURCHASER.
6. This Limited Warranty gives you specific legal rights. You may also have other rights, which vary from one jurisdiction to another.

RETURN INFORMATION

- A Return Authorization number must be obtained from Numark through the address or phone numbers below.
- A copy of the original sales receipt must also be included for the equipment to be repaired under warranty.
- The faulty equipment must be packed in its original packaging.
- One additional outer layer of packaging must be included to ensure product safety. Failures to do so may inadequately protect the equipment in transit and, therefore, jeopardize the customer's warranty.
- Numark will not accept COD shipments and no call tags will be issued for merchandise return.
- Numark will not return repaired merchandise to customers by priority service, unless by written request at the customer's cost. Requests must be submitted in writing with merchandise returned.
- The defective Numark equipment should be sent, FREIGHT PREPAID with Return Authorization number clearly printed on the outer packaging and original sales receipt enclosed to:

Numark INDUSTRIES
Attention: Service Department
11 Helmsman Avenue
North Kingstown, RI 02852 USA

Phone: +1 (401) 295-9000
Fax: +1 (401) 295-5200
Web: www.numark.com

Free Manuals Download Website

<http://myh66.com>

<http://usermanuals.us>

<http://www.somanuals.com>

<http://www.4manuals.cc>

<http://www.manual-lib.com>

<http://www.404manual.com>

<http://www.luxmanual.com>

<http://aubethermostatmanual.com>

Golf course search by state

<http://golfingnear.com>

Email search by domain

<http://emailbydomain.com>

Auto manuals search

<http://auto.somanuals.com>

TV manuals search

<http://tv.somanuals.com>