

**OLYMPUS®**

# Infinity Zoom 230









■ INSTRUCTIONS

# Table of contents

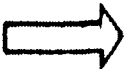
Description of controls .....	3	Remote control .....	26
Before you begin		Super macro photography .....	30
Loading the batteries .....	6	Spot mode .....	32
Checking the batteries .....	7	Auto-zoom mode .....	35
Adjusting the viewfinder.....	8	Continuous mode .....	37
Attaching the strap.....	9	Selftimer .....	38
Loading the film .....	10	AUTO-S flash photography .....	40
Unloading the film .....	13	Flash OFF .....	41
Simple point & shoot photography		FILL-IN flash .....	42
How to take pictures .....	15	Night scene flash photography .....	43
Auto flash photography		How to use the filters (optional).....	45
(1)Taking pictures in low light .....	20	How to use the soft case (optional) .....	47
(2)Taking backlit subjects .....	23	Care and storage .....	48
Advanced shooting techniques		Questions and answers .....	50
Focus lock .....	24	Specifications .....	52

Thank you for purchasing the OLYMPUS Infinity Zoom 230. Please read this instruction manual carefully before using the camera. This camera will not operate unless the batteries are loaded and the power switch is set ON. Before taking important pictures, it is recommended that you shoot a roll of film just to familiarize yourself with the camera's features.

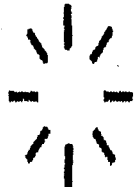
### Symbols used in this manual

					
Correct	Incorrect	Operation	Order	Operation order	Automatic operation
					
Attention	Operation sound	Lamp on	Lamp blinking	Press lightly	

# Description of controls

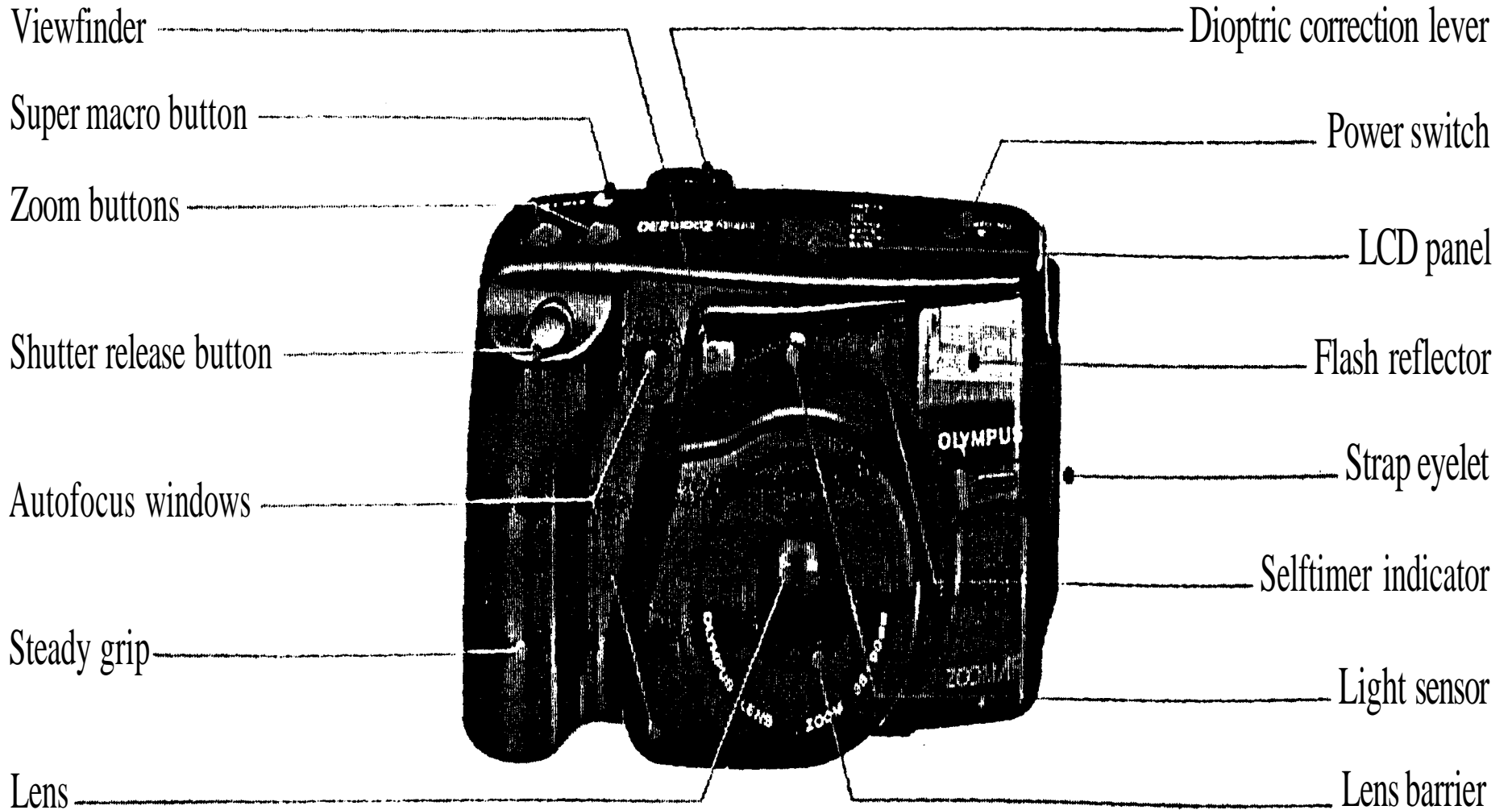

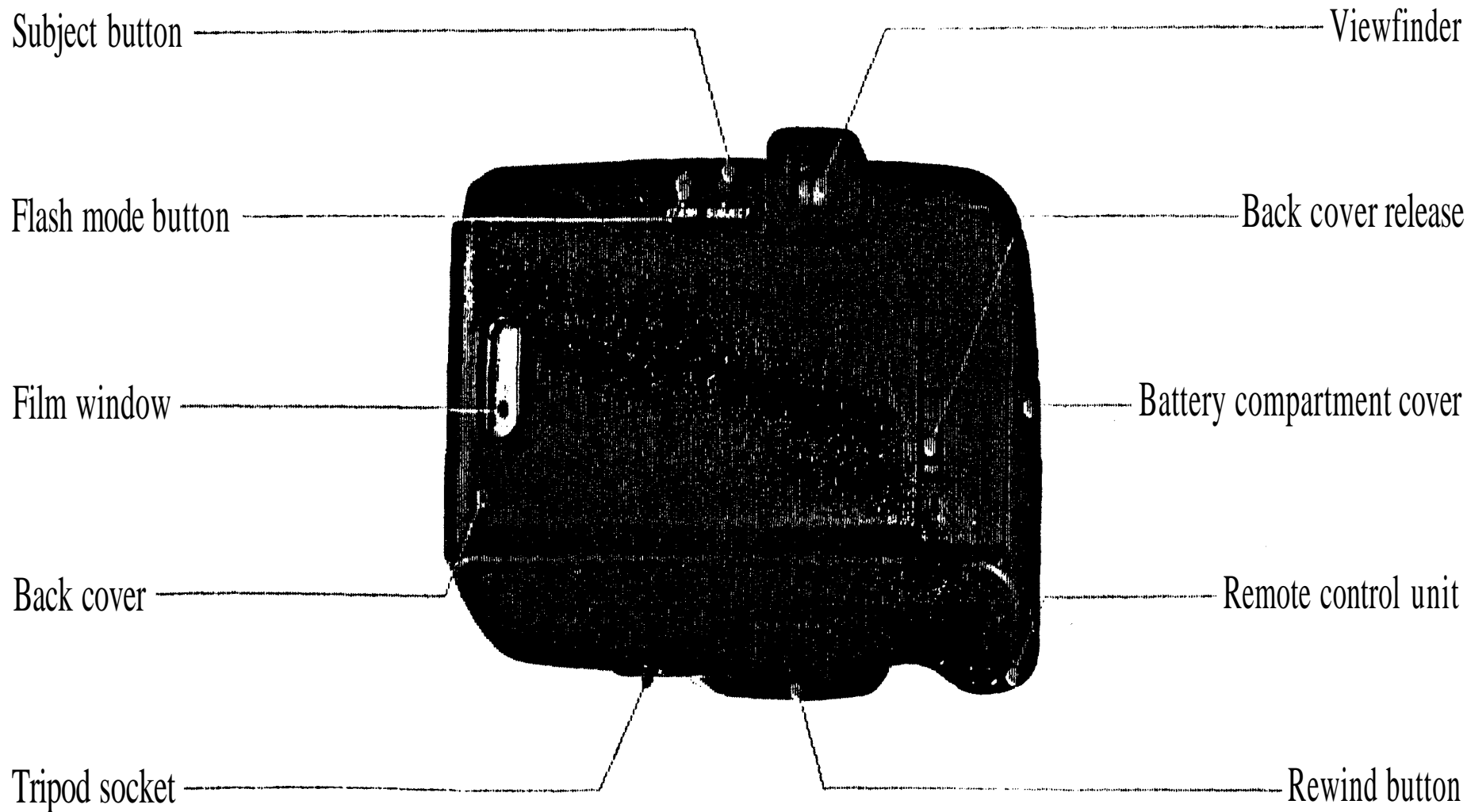

# Viewfinder display

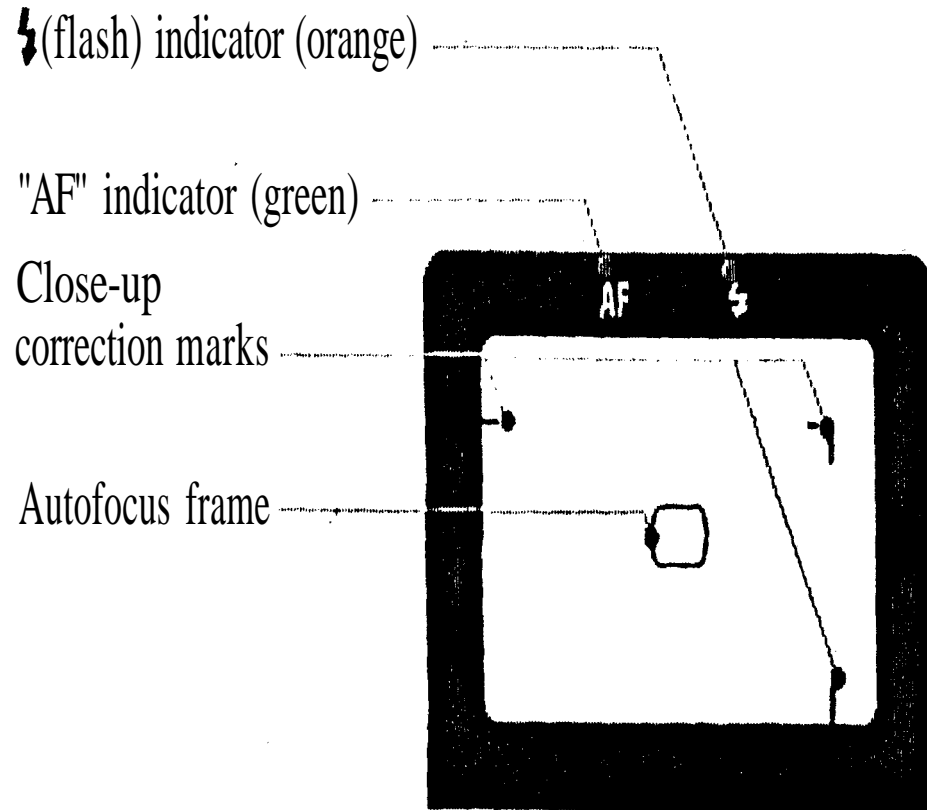

- ⚡ (flash) indicator (orange)
- "AF" indicator (green)
- Close-up correction marks
- Autofocus frame
- Flash mode
- Flash mode selection

# LCD panel

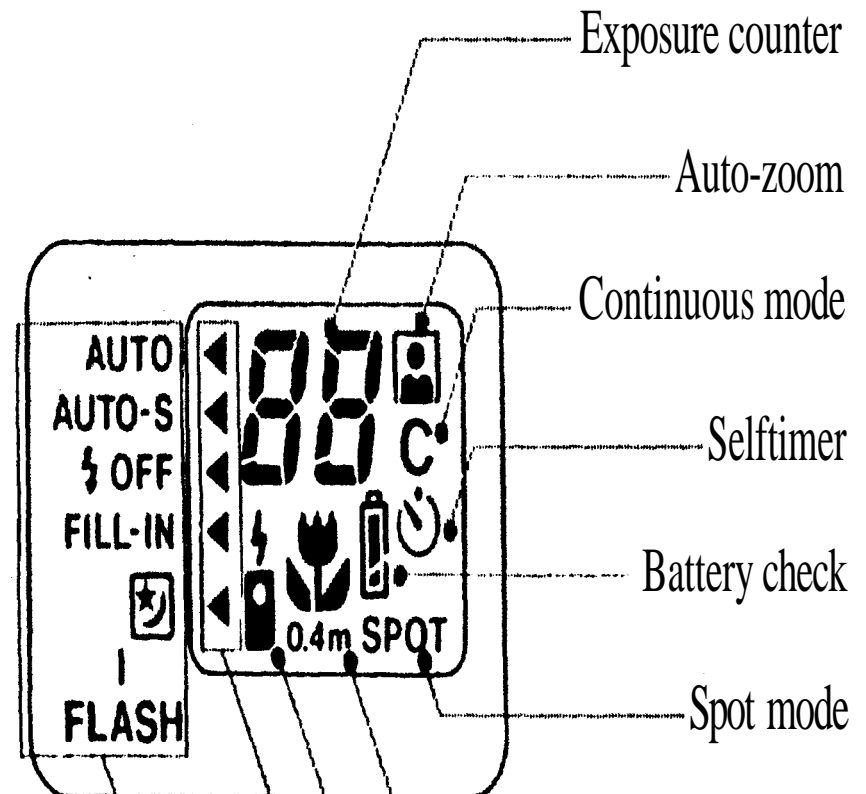

- Exposure counter
- Auto-zoom
- Continuous mode
- Selftimer
- Battery check
- Spot mode
- Super macro
- Remote control

**Before you begin...**

## Loading the batteries

**1** Remove battery cover on the side of the grip.

\*Before replacing the batteries, set the power switch OFF.

**2** Insert two 3V lithium batteries as shown and replace the cover.

Use Panasonic CR123A, Duracell DL123A, or equivalent.

\*Do not mix different types of batteries or new and old batteries at the same time.

\*Remove batteries if you do not plan to use the camera for an extended period of time (more than a year).

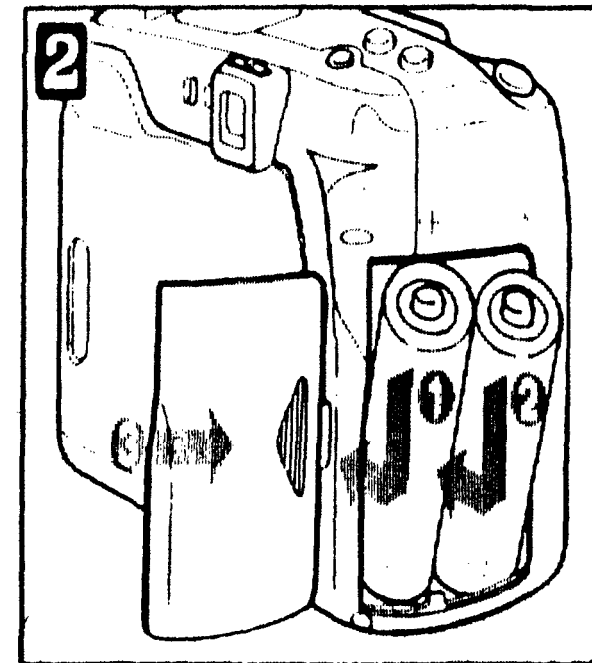
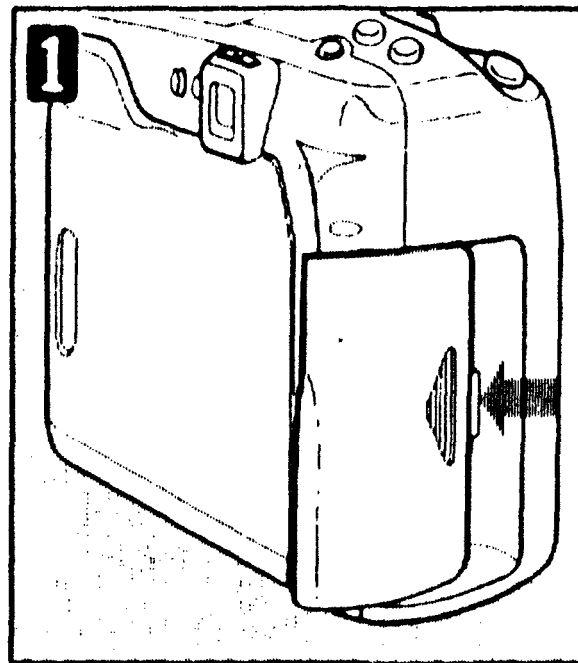

## Checking the batteries

Turn power ON by sliding the power switch as shown.

The battery check indicator will be displayed for 12 seconds.

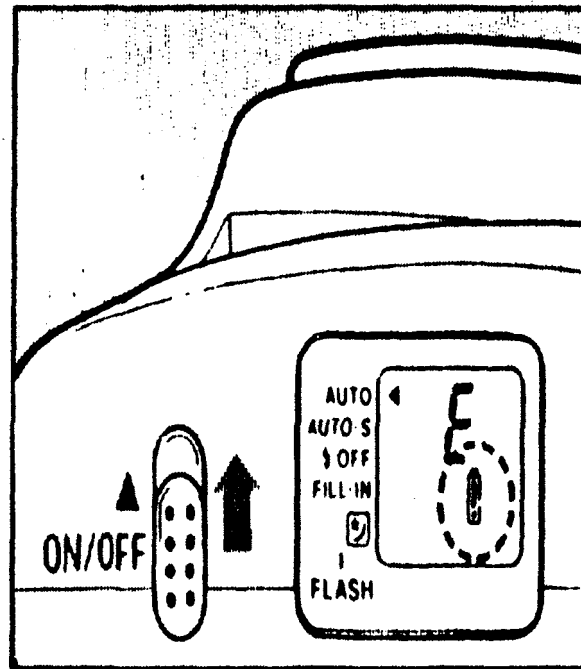

When "E" is displayed, batteries are OK.

If "E" flashes, batteries are low, have spares handy.

If "E" is displayed continuously, batteries should be replaced immediately.

\*When the battery power is low, the flash will take longer to recharge.

\*To turn OFF, slide the power switch again.



## Adjusting the viewfinder

A dioptic correction lever on the viewfinder eyepiece allows you to adjust the clarity of the viewfinder image. This is especially helpful for photographers who wear eyeglasses.

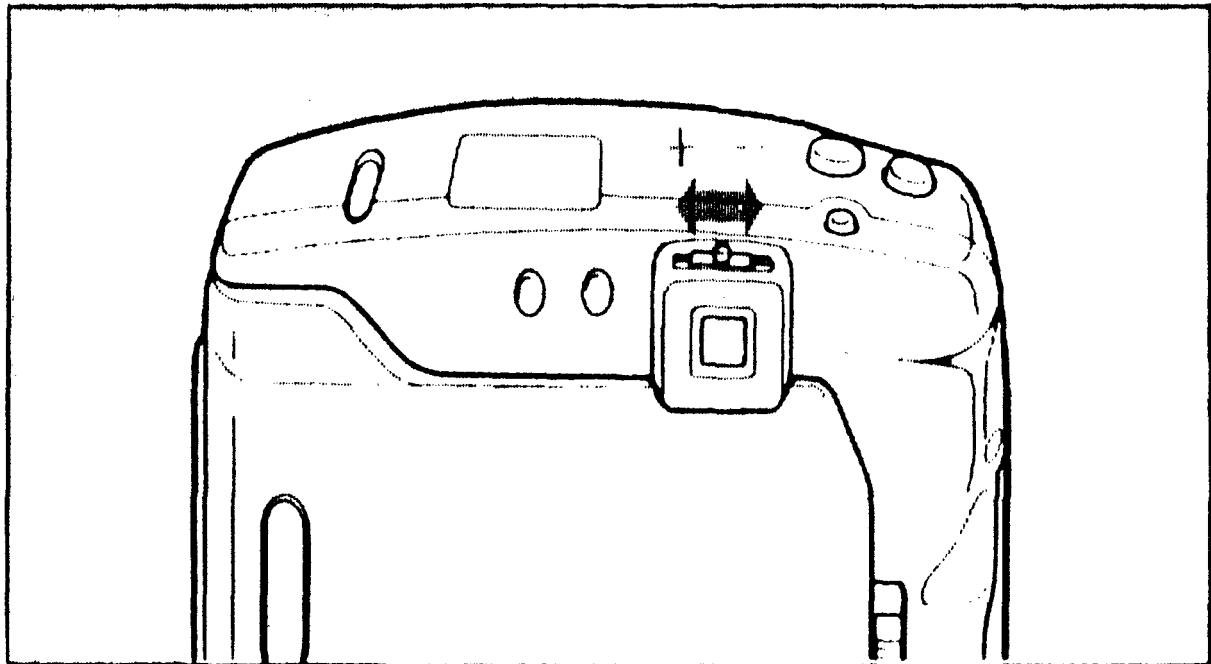

## Attaching the strap

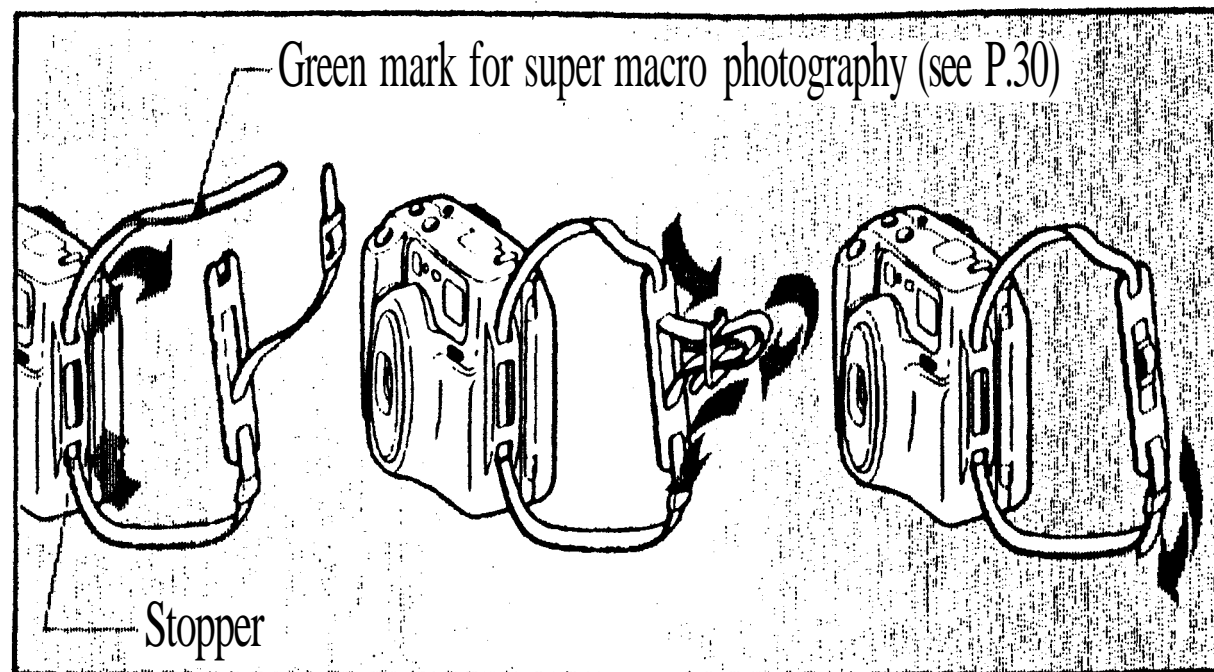

## Loading the film

This camera is designed to use DX-coded 35mm film. DX coding, used by virtually all major film manufacturers, allows the camera to identify and set the film speed automatically. If DX-coded film is unavailable, use ISO 100 film.

**1** Open the back cover by sliding the back cover release toward the top of the camera.

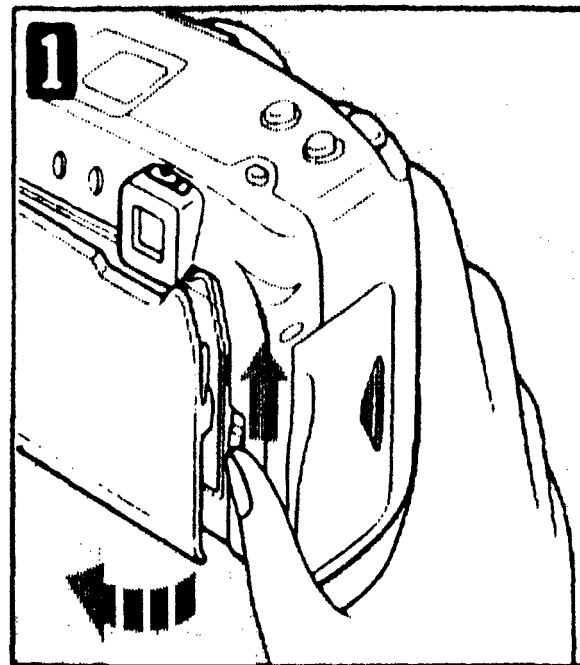

**2** Insert the film cartridge into the camera. Always avoid direct sunlight when loading the film.

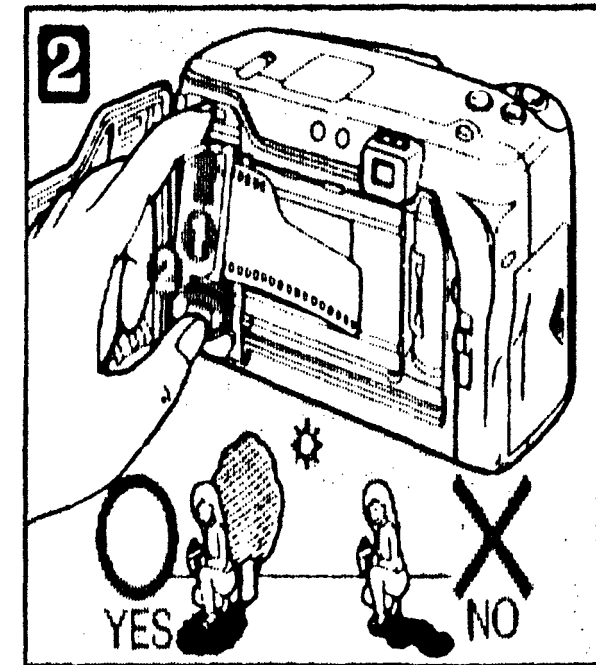

**3** Make sure the film lies flat.

**4** Align the film leader with the red film loading indicator.

Unless the film leader matches the film loading indicator, the film may not be loaded.

\*Do not touch the lens inside the body with your fingers or the film leader.

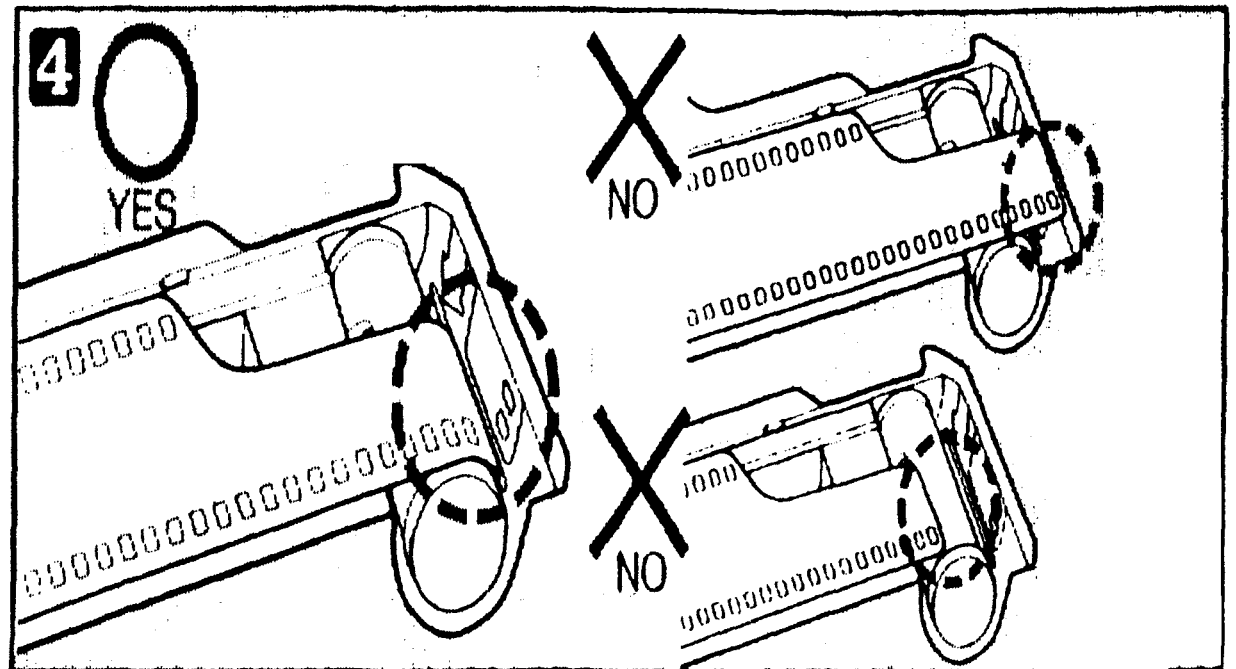
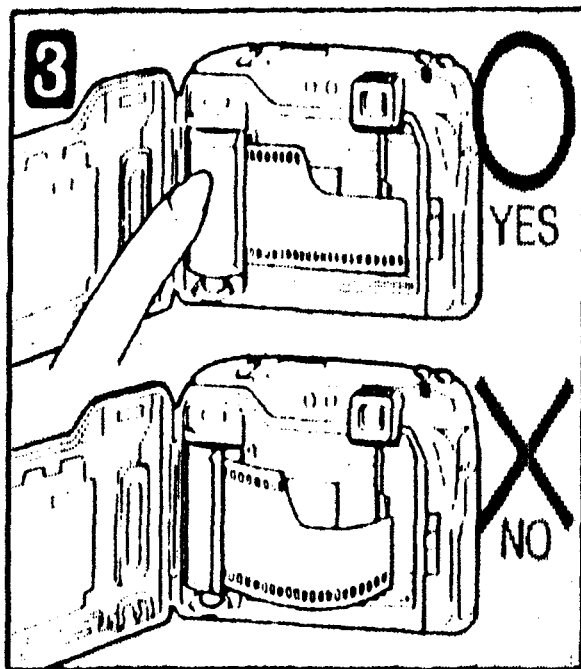

**5** Close the back cover. The film automatically advances to the first frame.

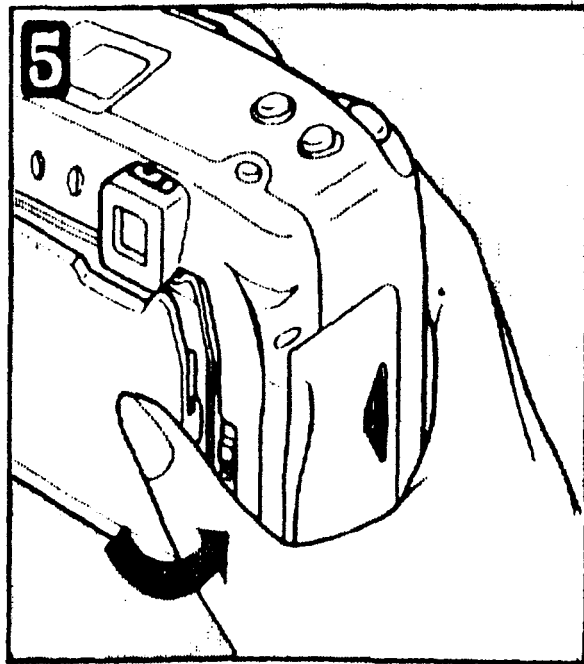

**6** Set the power switch ON to make sure that the exposure counter shows "1".

If film is improperly loaded, the LCD panel will display a blinking "E". In this case, open the back cover, and realign the film leader.

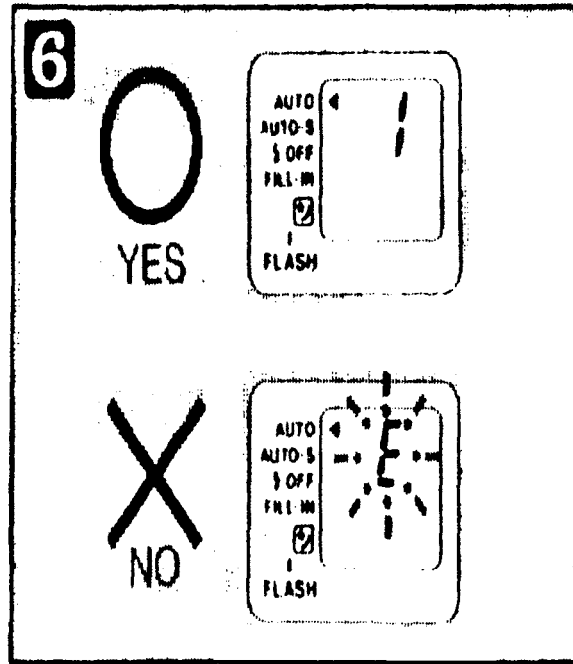

Use the window in the camera back to check type of film loaded.

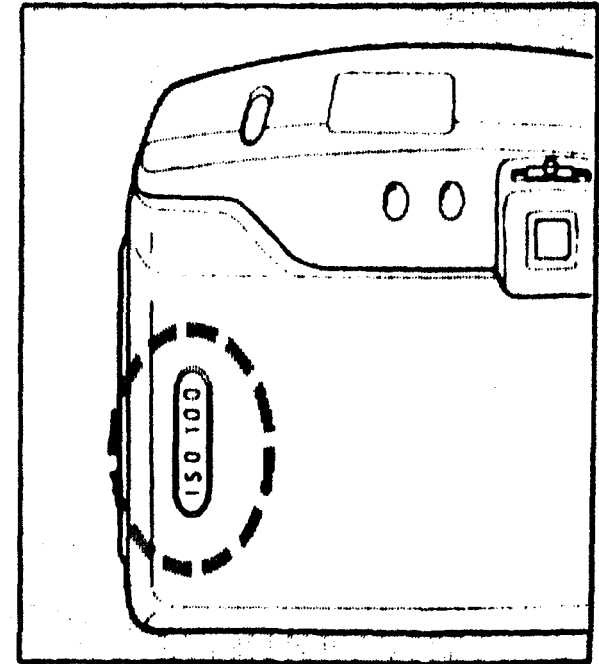

# Unloading the film

**1** The camera automatically rewinds the film when you reach the end of a roll. The exposure counter on the LCD panel counts down as the film is rewinding.

\*The final reading of the exposure counter before rewinding may be more than the number of exposures specified for the film.

If you want to rewind the film before the end of the roll, press the rewind button with the tip of a ballpoint pen. Do not use any device with a sharp tip.

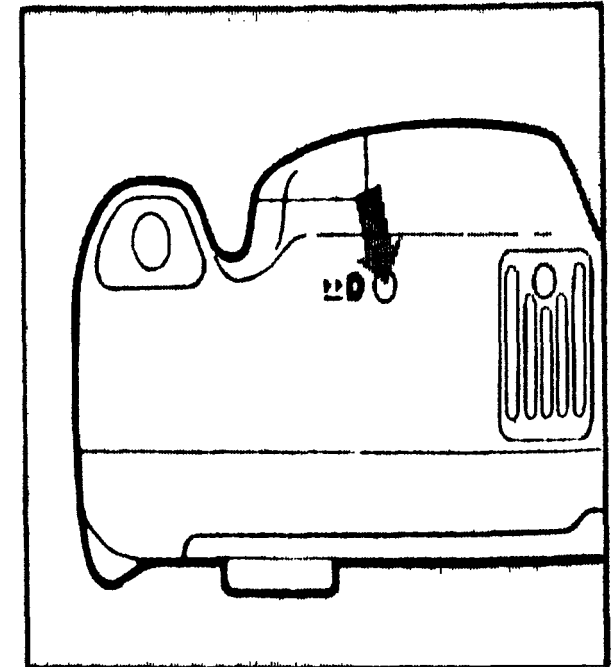
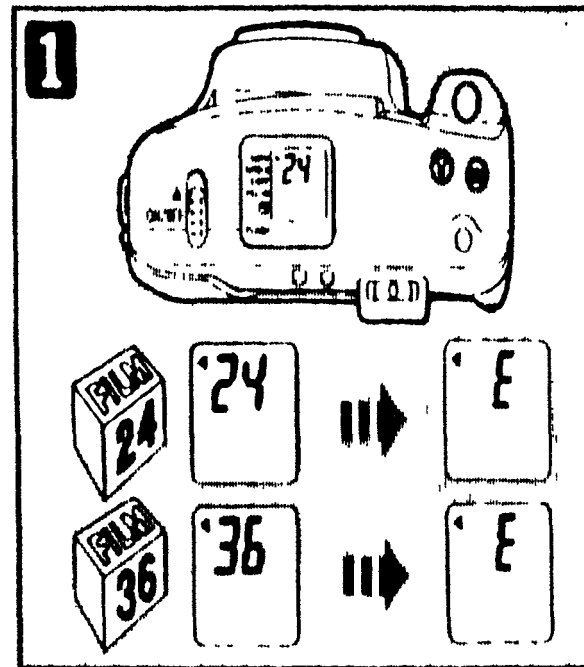

**2** Once the film has been rewound, a blinking "E" will be displayed on the LCD panel. Further operations are not possible until the rewind film cartridge is removed.

**3** Open the back cover, and remove the film cartridge from the camera. Avoid direct sunlight when removing the film.

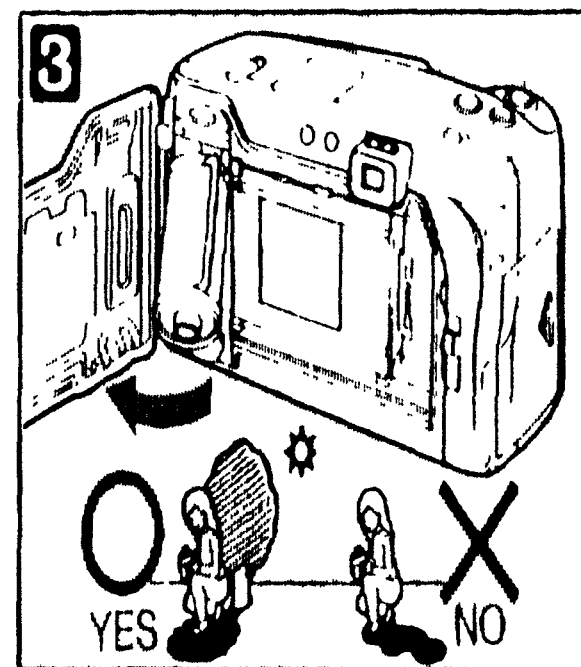
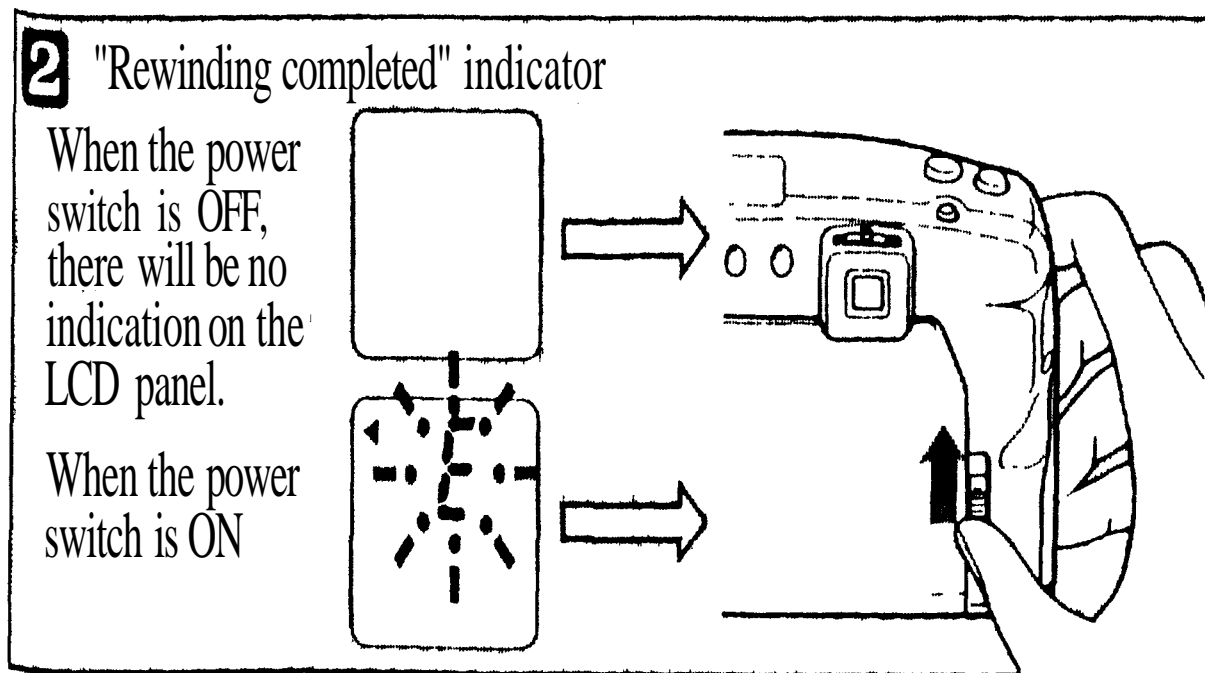

# Simple point & shoot photography

## How to take pictures

When the power switch is ON, the LCD panel lights. The LCD panel goes out after 4 to 5 minutes to minimize battery drain. After 4 hours the power is automatically turned OFF. To resume operation, set the power switch OFF and then ON again.

- 1** Set the power switch ON.  
\*When the camera is not in use, always set the power switch OFF so that the shutter cannot be activated accidentally.

- 2** While looking through the viewfinder, aim the camera at your subject.

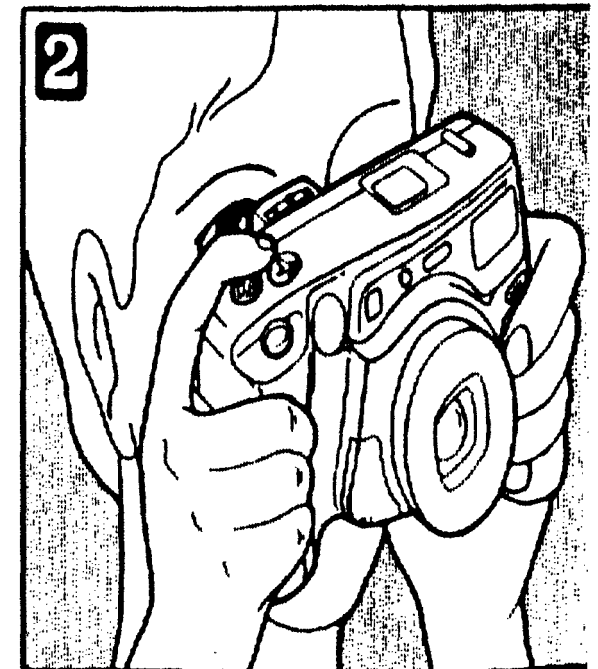
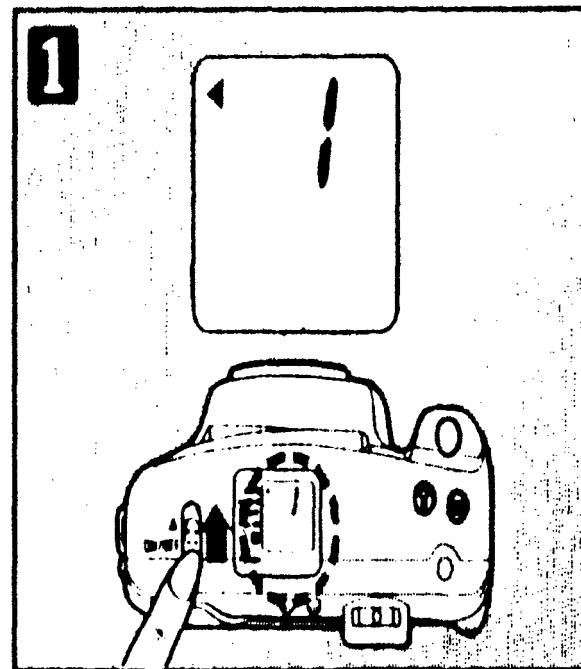



**3** Use the zoom buttons to adjust the size of your subject in the frame.  
(telephoto or wide-angle)

The shutter release cannot be operated while zooming.

Press the "T" (Telephoto) button to zoom in. (The maximum focal length in the "T" position is 90mm.)

Press the "W" (Wide-angle) button to zoom out. (The minimum focal length in the "W" position is 38mm).

**4** Hold the camera correctly.

It is particularly important to hold the camera steady when shooting at a longer focal length; use both hands for maximum stability.

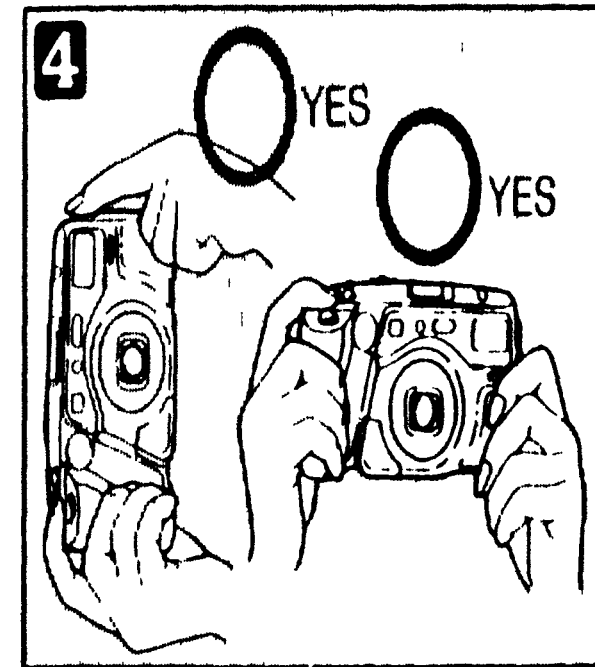
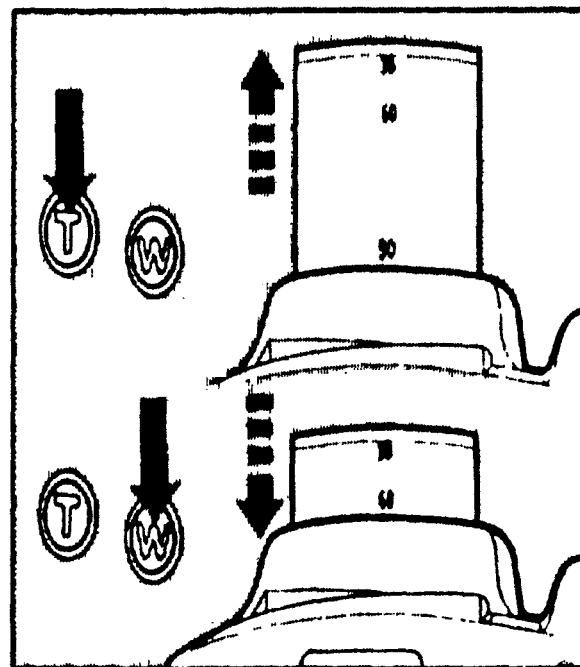
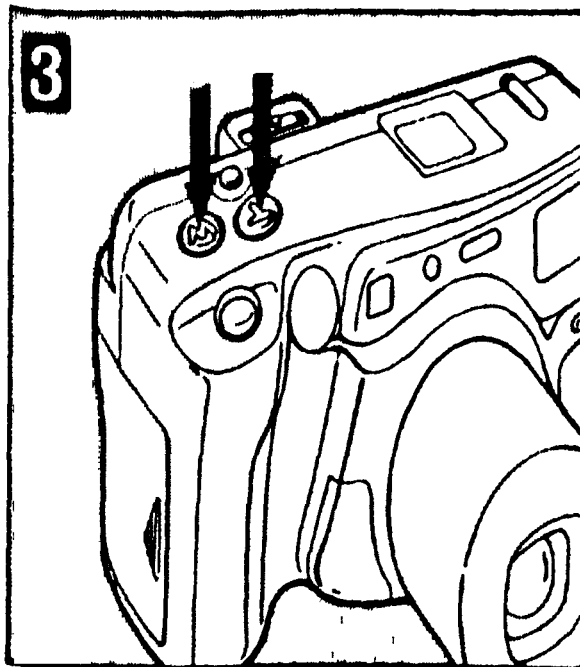

\*Keep your fingers and the strap away from the lens, flash, autofocus windows and light sensor.

**5** Position your subject within the autofocus frame in the viewfinder. With the composition shown on the right, the background will be in focus as the autofocus frame does not cover the subject. In this case, use the focus lock to keep the subject in focus. (Refer to page 24.)

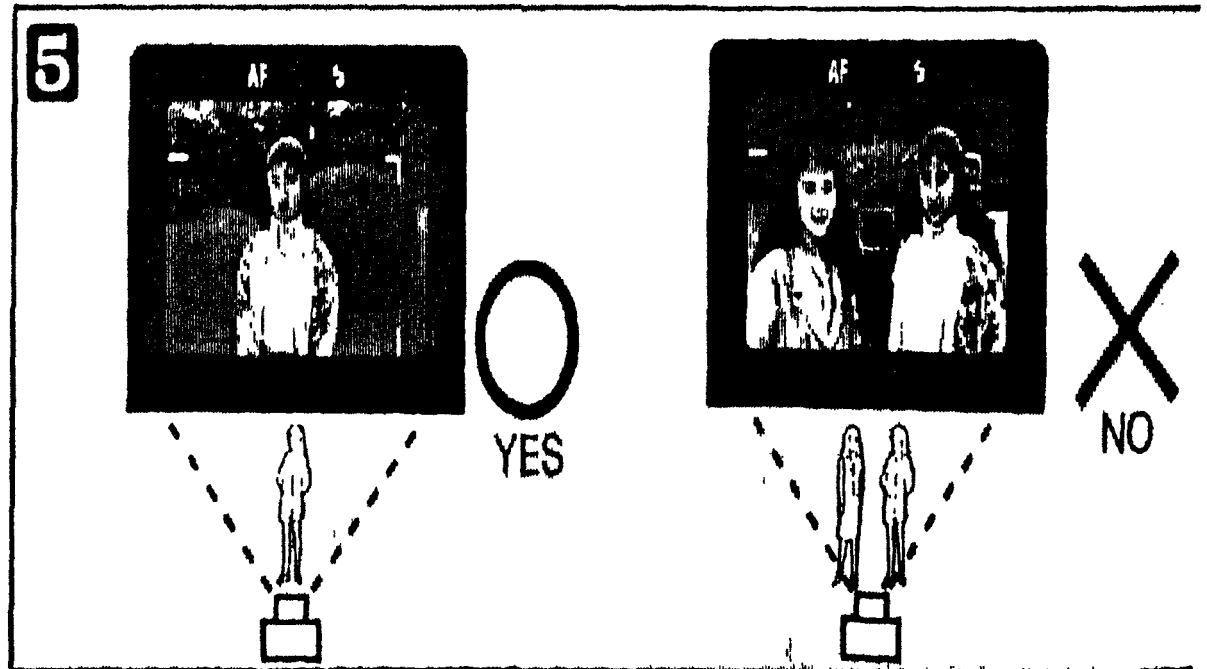
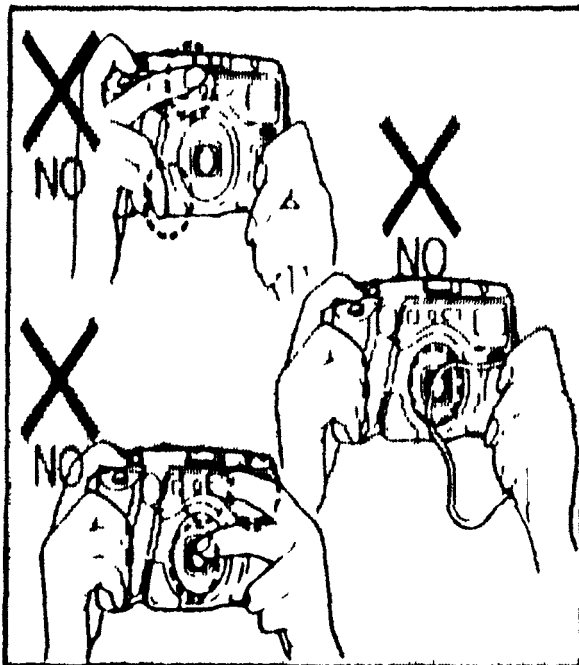

**6** Press the shutter release button halfway to focus.

When correct focus has been achieved, the "AF" indicator (green) will light up in the viewfinder.

If the "AF" indicator is blinking, correct focus has not been achieved. If this occurs, let go of the shutter release button. Make sure your subject is within the autofocus frame in the viewfinder and press the shutter release button halfway again.

The entire subject should normally be positioned within the picture frame, however, the actual available image area will become smaller as you get nearer to the subject. At 0.6m (2ft), the subject should be positioned within the close-up correction marks.

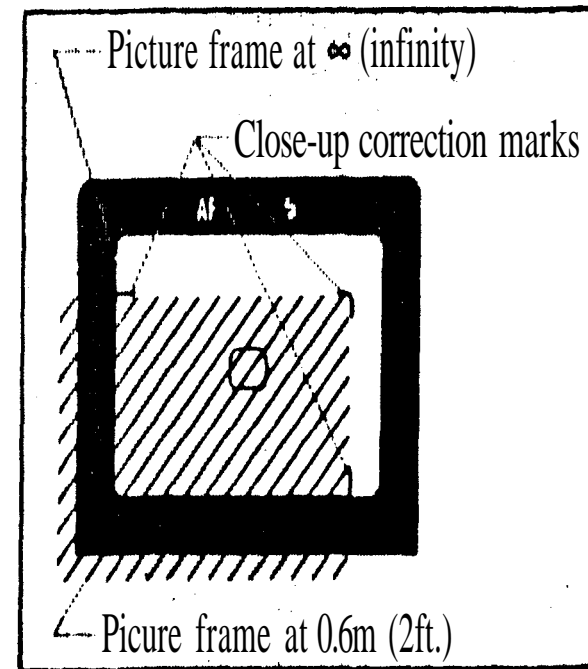
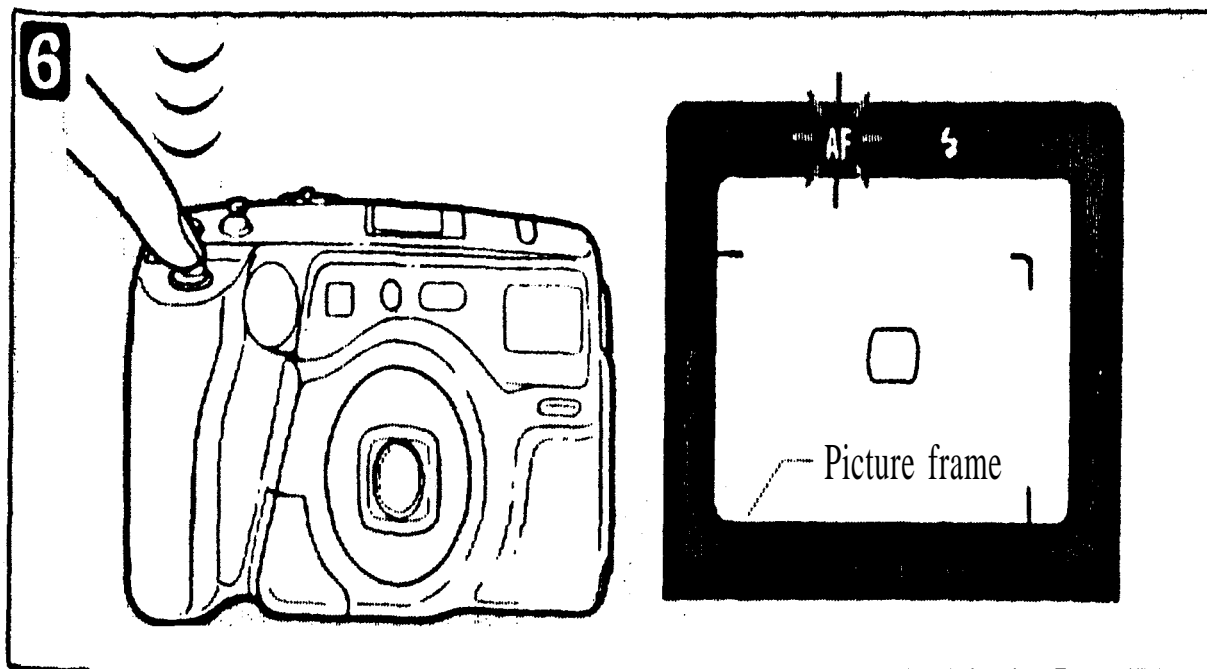

If the subject is nearer than 0.6m (2ft), the "AF" indicator (green) will blink and the shutter will not release. However, the shutter may sometimes be released erroneously when the subject is extremely close to the camera.

Shooting range: from 0.6m (2ft) to  $\infty$  (infinity).

At 0.4m (1.3ft) you can take pictures with super macro mode. (Refer to page 30.)

**7** When correct focus has been achieved (the "AF" indicator has lit up), press the shutter release button fully (gently, to minimize camera shake).

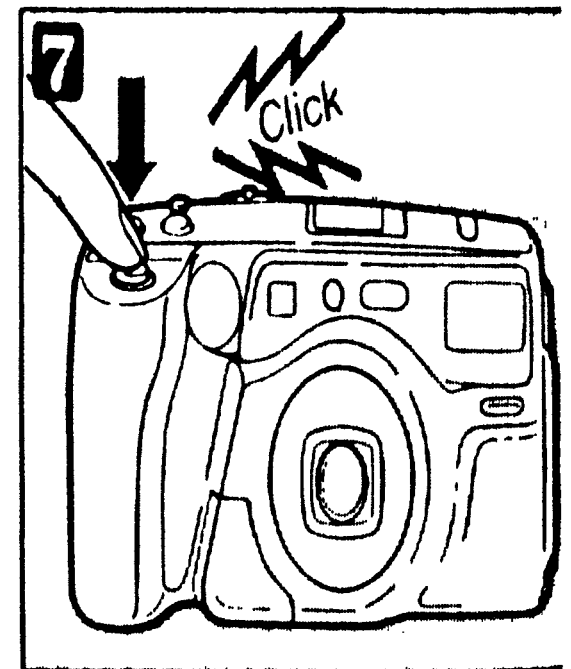
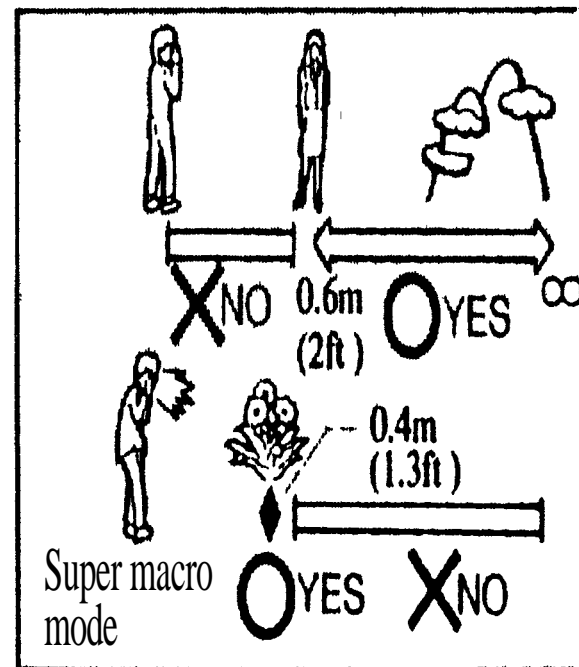
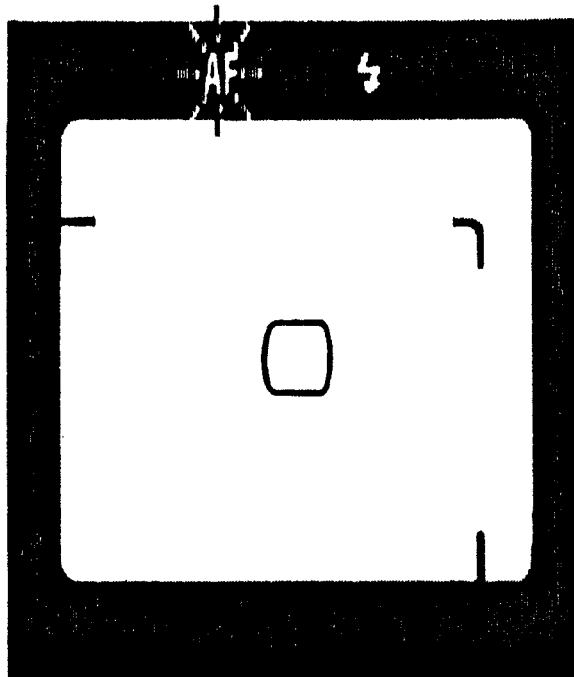

**8** As soon as the shutter is released, the film will automatically advance to the next frame. The LCD exposure counter shows the next frame number.

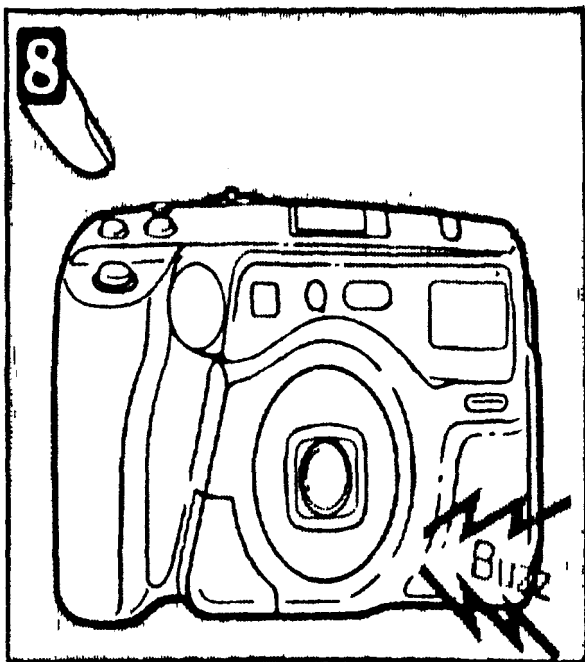

## Auto flash photography

### (1) Taking pictures in low light

When the flash mode is set to AUTO or AUTO-S, the flash will fire automatically in low light conditions.

Confirm flash charge by pressing the shutter release button halfway. The ⚡ indicator (orange) will light up in the viewfinder when the flash is charged. Compose your shot and press the shutter release button. The flash will fire automatically.

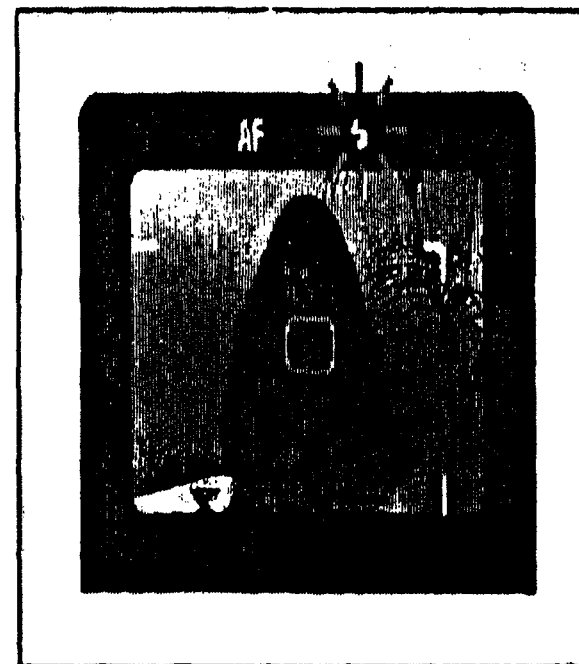

The shutter release cannot be operated while the flash is charging.

It takes about 0.2—3.5 seconds after the film is advanced to recharge the flash (at normal temperatures with new batteries).

NOTE: To significantly reduce red-eye phenomenon, use the AUTO-S flash mode (P.40).

From 0.6m(2ft) to 1.6m(5.2ft), the flash strength is controlled automatically as shown. This soft flash mechanism prevents pictures from being overexposed.

Soft flash:

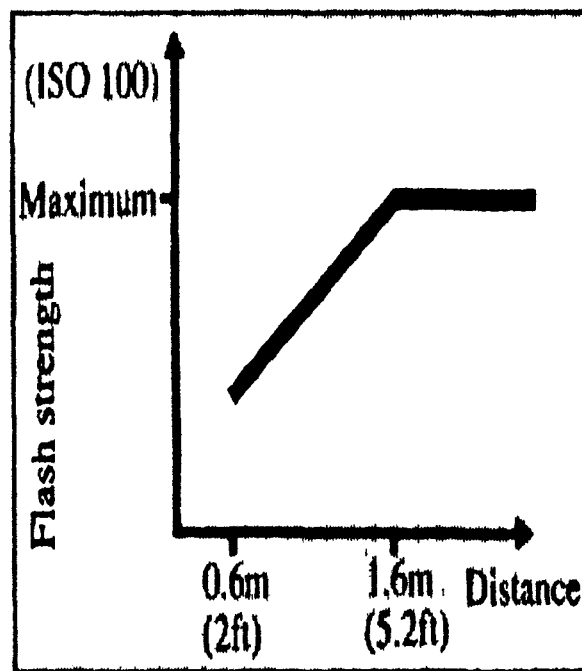
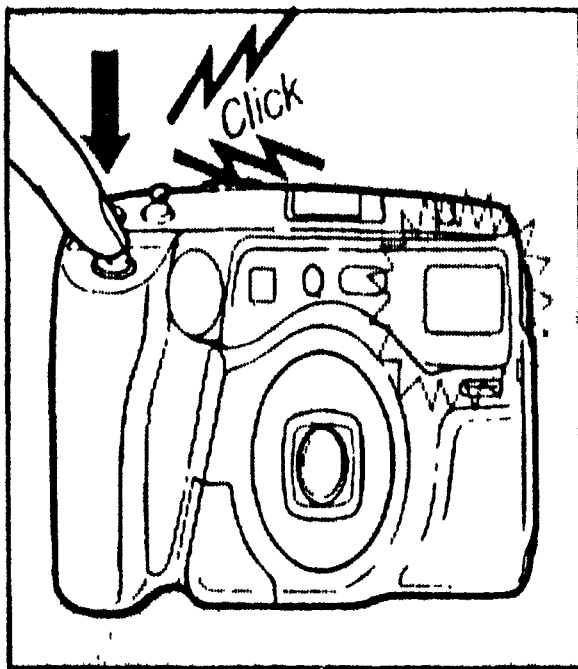

Overexposed (with conventional flash).



Color negative film offers the widest exposure latitude, compensating for over and underexposure more readily than other films. The flash working range shown below is optimal for color negative film. Actual flash working range for other film type may vary.

Properly exposed (with soft flash).



Flash working range:

ISO	WIDE (38mm)	TELE (90mm)
100	0.6m—4.3m(2ft—14.1ft)	0.6m—2.7m(2ft—8.9ft)
200	0.6m—6.1m(2ft—20ft)	0.6m—3.8m(2ft—12.5ft)
400	0.6m—8.6m(2ft—28.2ft)	0.6m—5.4m(2ft—17.7ft)

In continuous mode

ISO	WIDE (38mm)	TELE (90mm)
100	0.6m—3.5m(2ft—11.5ft)	0.6m—2.2m(2ft—7.2ft)
200	0.6m—4.9m(2ft—16.1ft)	0.6m—3.1m(2ft—10.2ft)
400	0.6m—7m(2ft—23ft)	0.6m—4.4m(2ft—14.4ft)

## Auto flash photography (2) Taking backlit subjects

When the flash mode is set to AUTO or AUTO-S, the flash will fire automatically in backlit situations.

Confirm flash charge by pressing the shutter release button halfway. The  indicator (orange) will light up in the viewfinder when the flash is charged. \*If the backlit subject is very small or is not in the center of the viewfinder, the flash may not fire automatically.

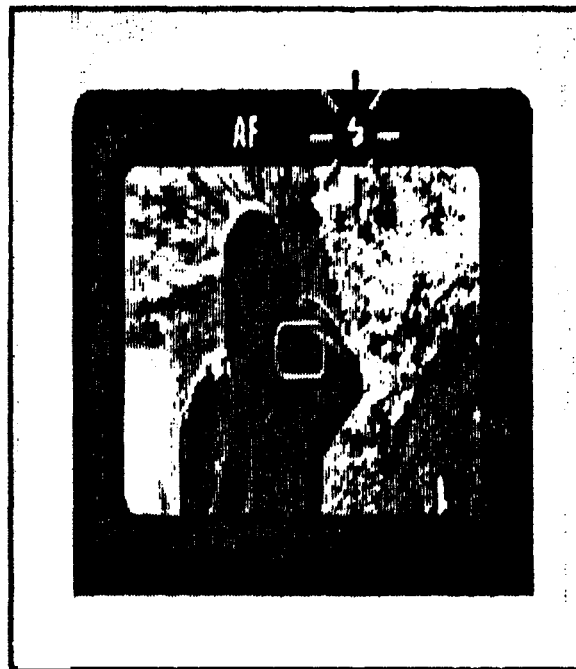



# Advanced shooting techniques

## Focus lock

Using the focus lock, your subject will be in focus even if it is not in the center of the picture.

When the main subject is not in the autofocus frame, use the focus lock.

Otherwise the camera will focus on the background and the subject will not be in focus.



**1** Position your subject in the autofocus frame and press the shutter release button halfway. The "AF" indicator (green) will light up in the viewfinder and the focus will be locked.

\*When focus is locked, exposure settings are also locked (AE lock).

**2** Recompose your picture while keeping the shutter release button pressed halfway.

\*If you remove your finger from the shutter release button, the "AF" indicator (green) will disappear and the focus lock will be canceled.

**3** Press the shutter release button fully to take the picture.

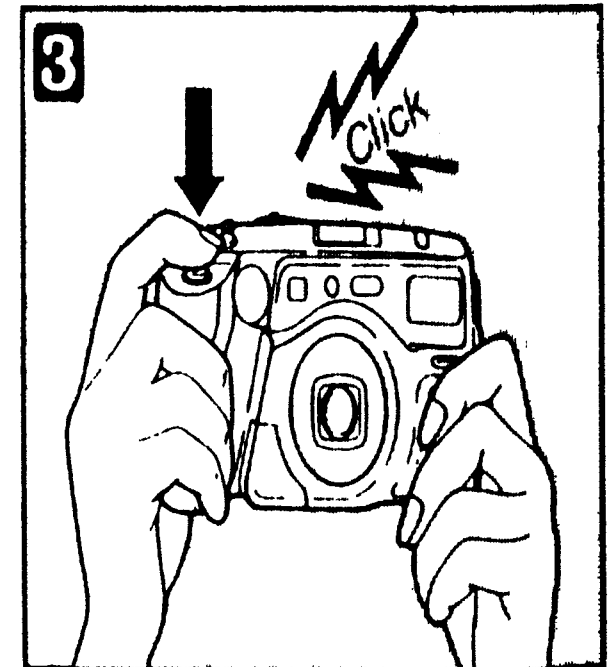
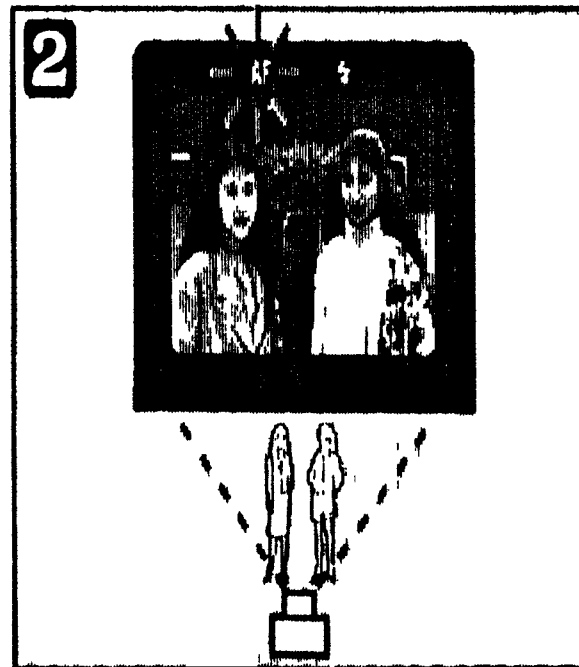
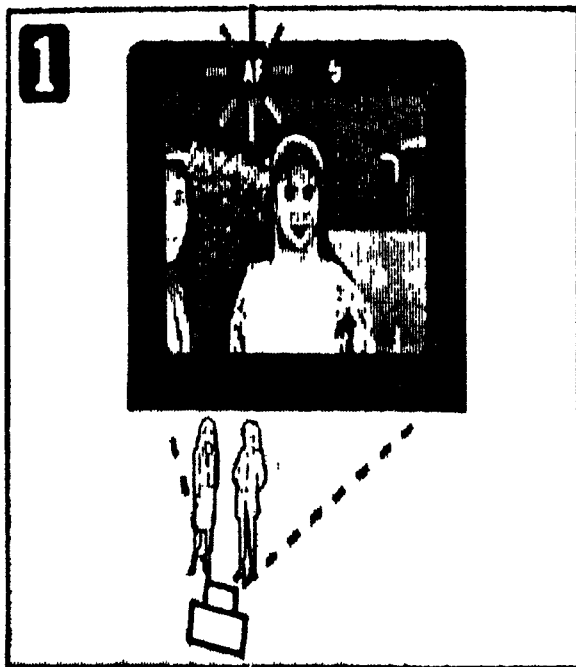

## Remote control

Use the remote control unit to take pictures when operating at a distance from the camera.

**1** Using a coin, turn the screw to remove the remote control unit from the bottom of the camera.

When the remote control unit has been removed from the camera, "🔋" blinks on the LCD panel.

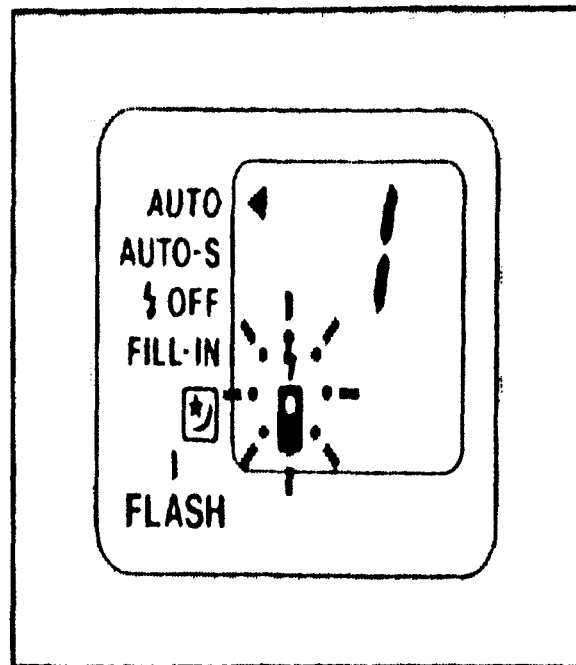
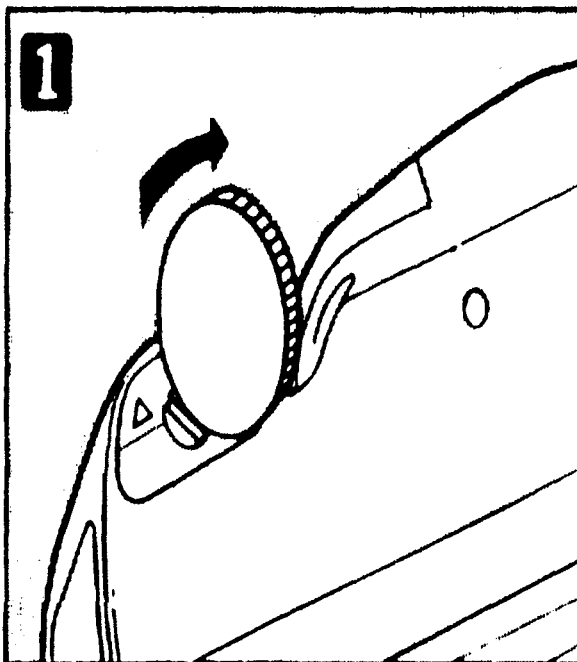

**2** The camera should be set firmly in position (with a tripod for example). While looking through the viewfinder, aim the camera at the subject.

**3** With the remote control unit in your hand, position yourself in front of the camera and press the release button on the unit's side.

\*The remote control unit functions at distances up to 5m (16.4ft) from the camera within an arc of about 30° (3.5m (11.5ft) to the right or left of

the center of the frame). Outside of this range use the selftimer.

\*Strong backlighting through the viewfinder may interfere with remote control operation.

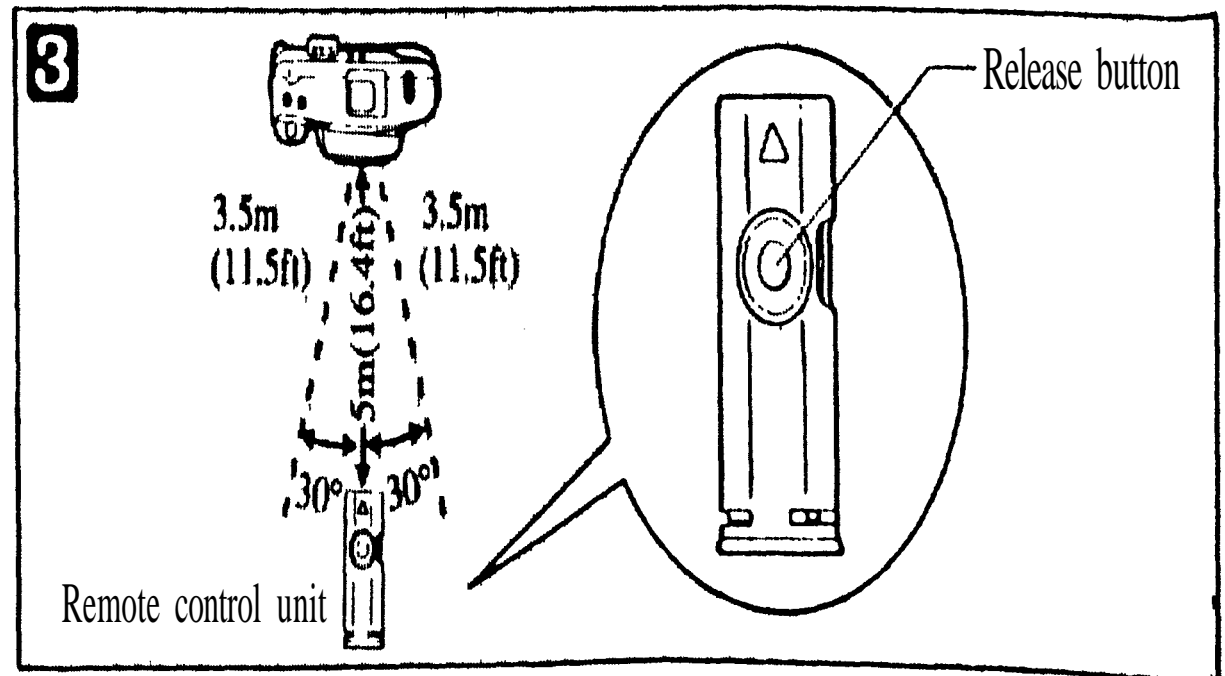
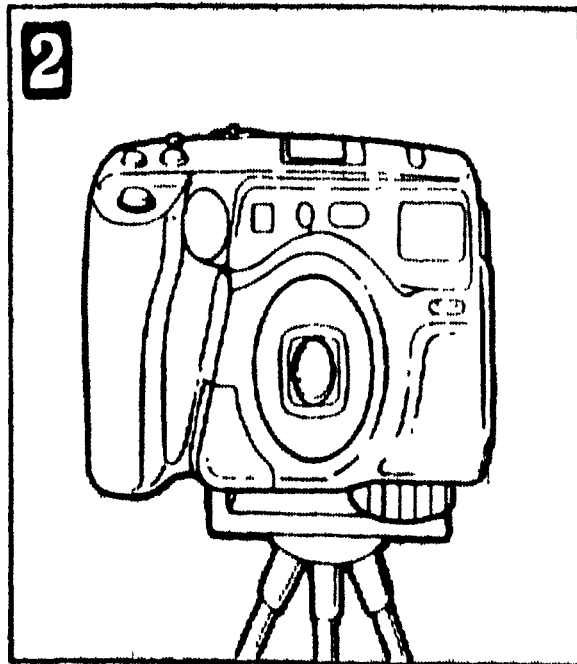

**4** The remote control can be set to release the shutter either 1 or 3 seconds after the release button is pressed.

**5** Press the release button. The selftimer indicator will blink rapidly until the shutter is released.

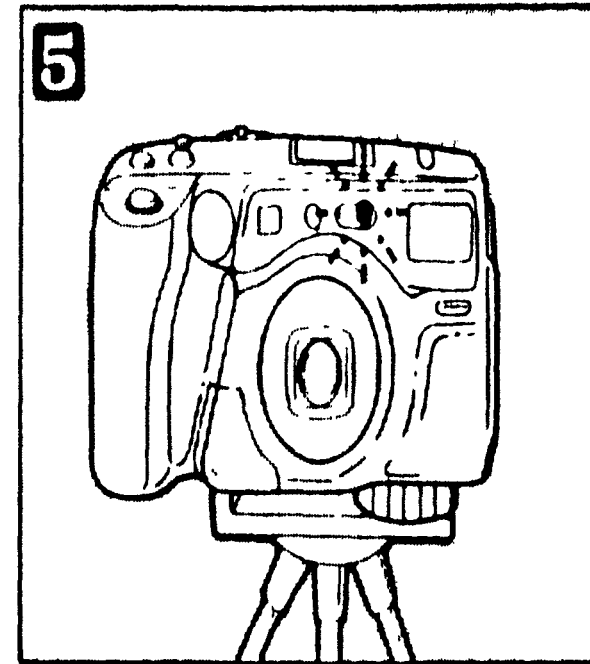
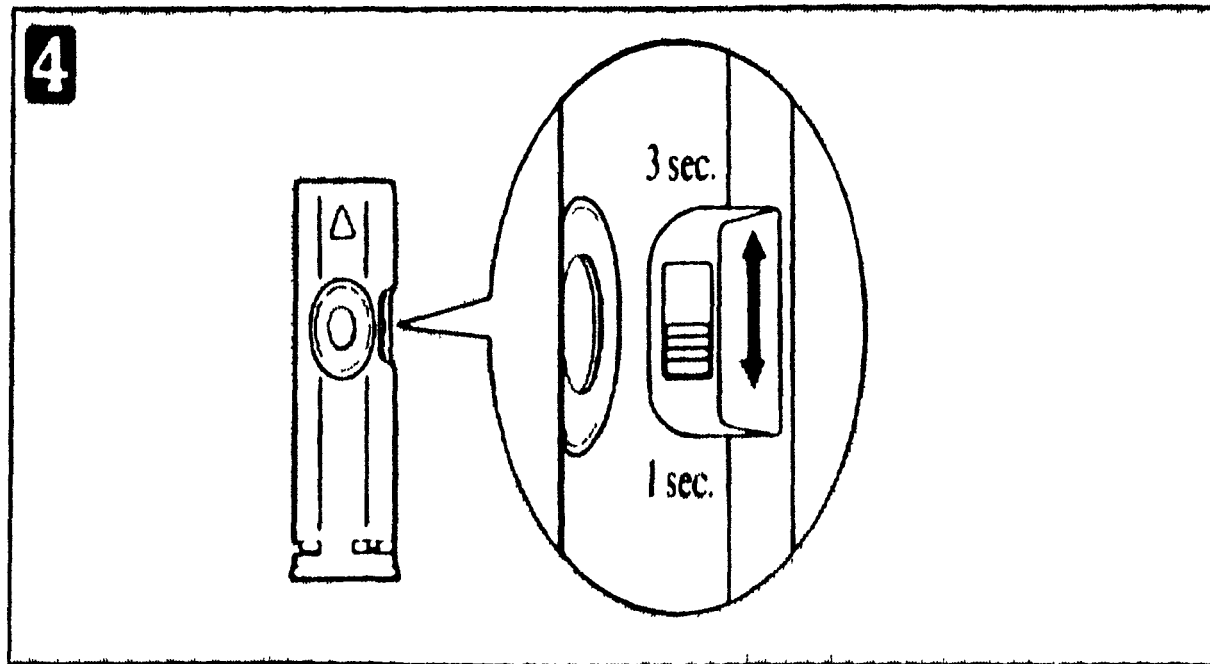

NOTE:

- The remote control unit will operate for approximately 18 minutes after removing it from the camera. Outside of this period the remote control unit cannot be operated. To resume operation, replace and then remove the remote control unit.
- Although all operating modes can be used in conjunction with the remote control unit, continuous-frame advance is limited to two frames.
- The battery of the remote control lasts approx. eight years. In case of battery drain, contact your local distributors.

**6** After using the remote control unit, replace it and lock it in place with a coin.

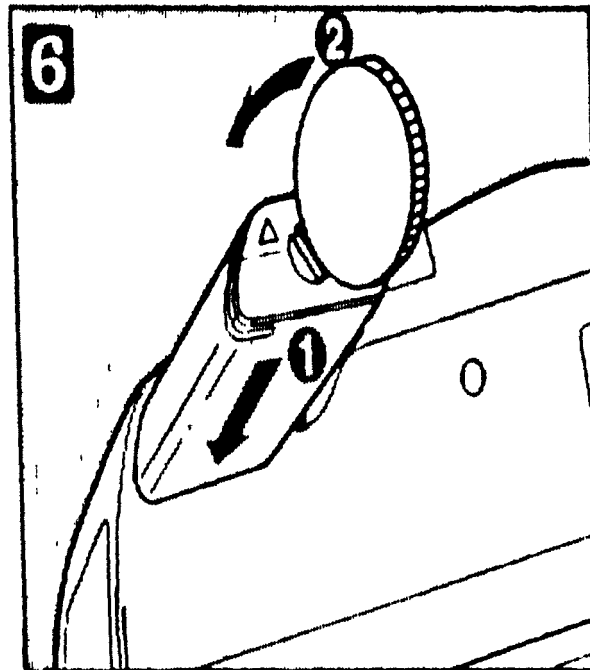

# Super macro photography

Super macro photography is possible at a distance of 0.4m (1.3ft).

Note: Without performing any special operations, macro photography is possible at any focal length up to a distance of 0.6m (2ft).

**1** Press the super macro button. The lens will automatically extend to telephoto and  will be displayed on the LCD panel.

\*In this mode, the flash always fires regardless of available light, though the flash mode indicator is set to AUTO.

**2** Pull the camera strap to adjust the stopper to the strap eyelet.

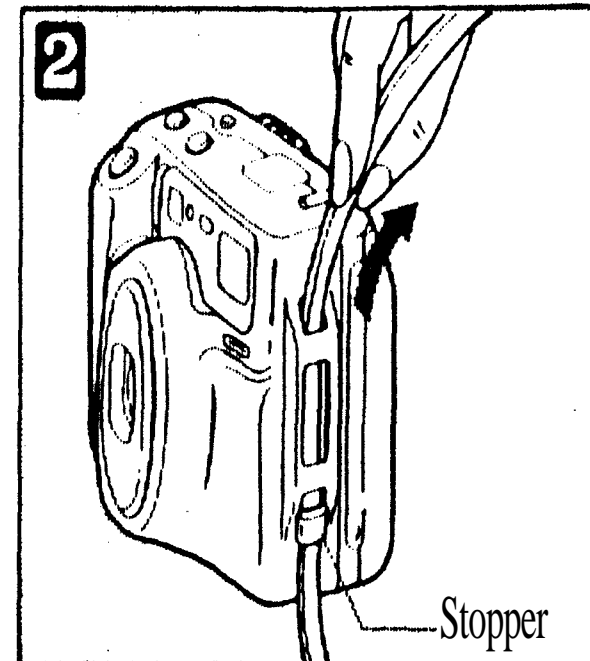
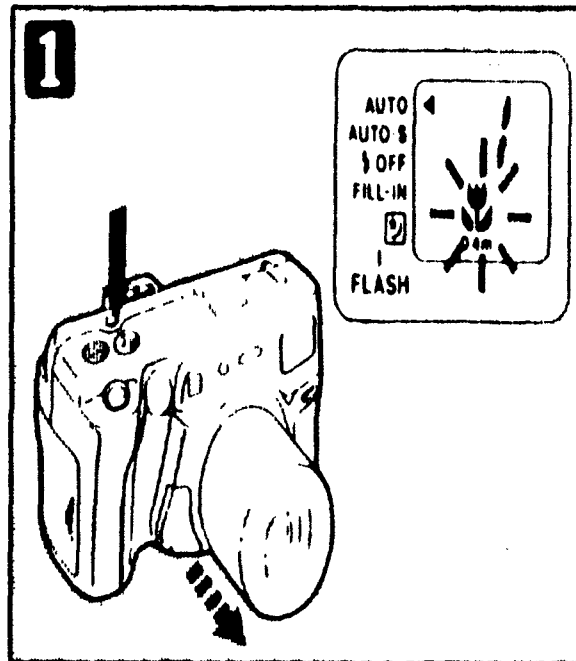

**3** Measure the distance of 0.4m (1.3ft) with the green mark on the strap.

\*Outside of 0.4m (1.3ft) the shutter will release, even though correct focus has not been achieved.

\*In this mode, the "AF" indicator (green) will not light up in the viewfinder.

At 0.4m (1.3ft), position your subject within the area outlined by the close-up correction marks.

The shaded area is the area that will actually be taken.

\*In this mode, none of the flash or subject modes can be used.

\*After releasing the shutter, the super macro mode will be automatically canceled.

\*To return to the normal shooting mode before releasing the shutter, press the super macro button or the zoom button.

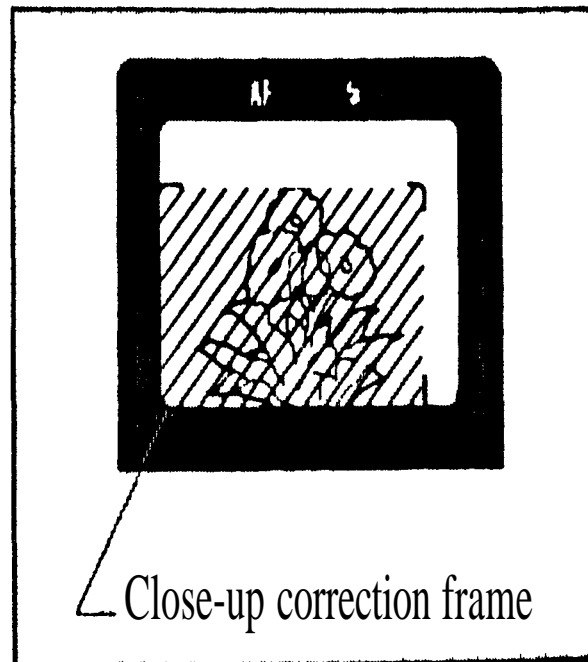
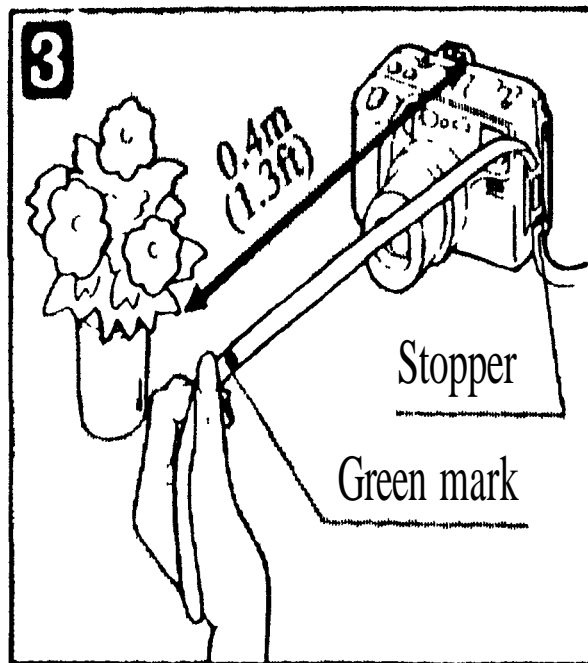



## Spot mode

Use the spot mode when you want to limit light metering to a particular area of the composition. In this mode, your subject will be properly exposed without being affected by backlight.

When there is strong backlight, your subject will appear too dark.



By using the spot mode, your subject will be properly exposed.



**1** Press the SUBJECT button until "SPOT" is displayed on the LCD panel.

**2** Position your subject in the autofocus frame in the center of the viewfinder and press the shutter release button halfway.

When correct focus has been achieved, the "AF" indicator (green) will light up in the viewfinder. The exposure and the focus will be locked in the autofocus frame.

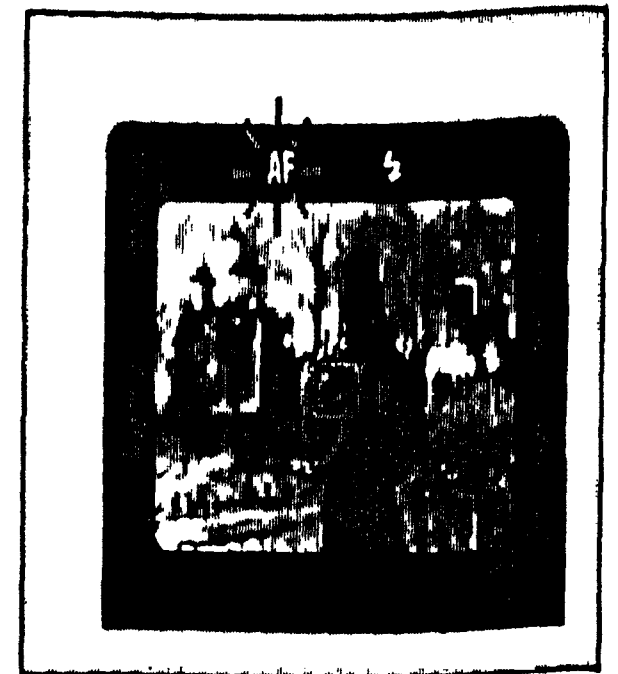
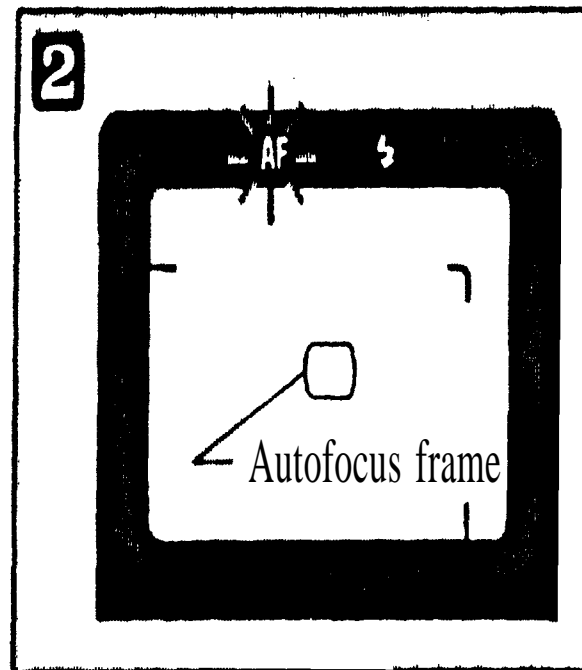
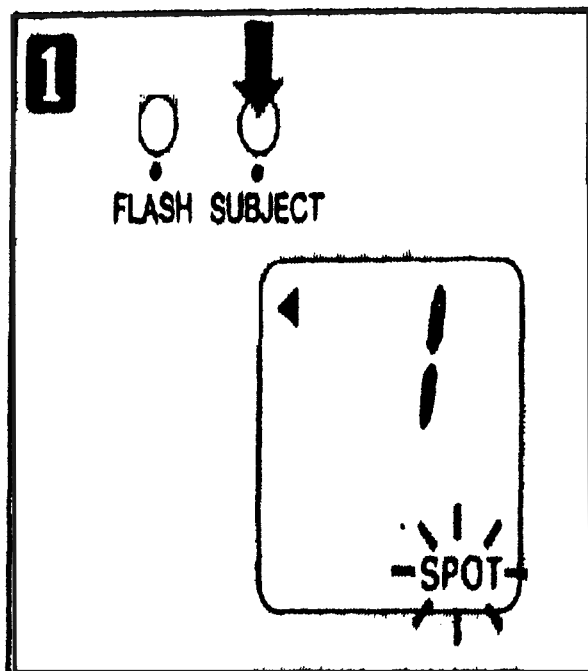

**3** While keeping the shutter release button pressed halfway, change the position of your subject in the viewfinder to achieve the desired composition.

**4** Press the shutter release button fully to take the picture.

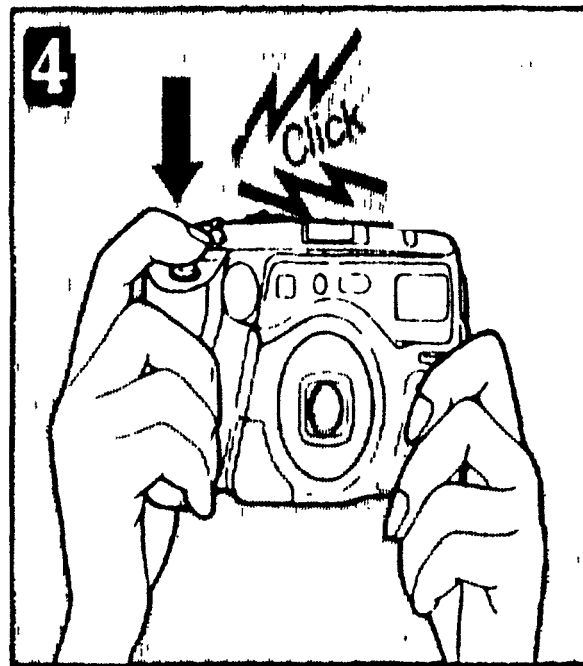
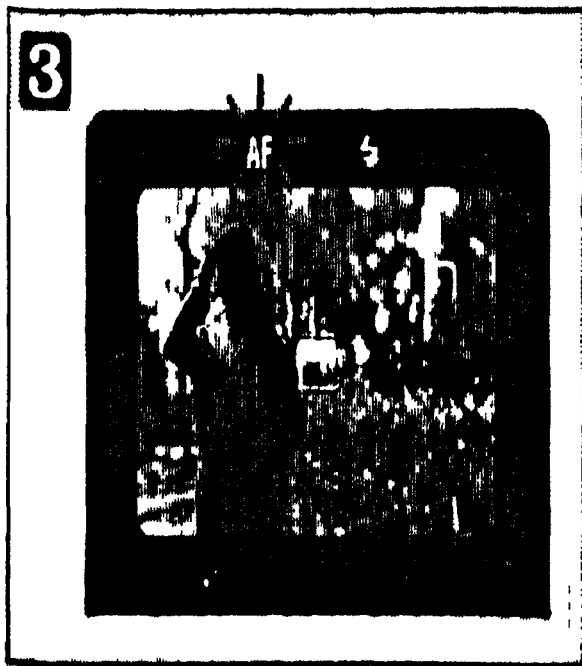

## Auto-zoom mode

Use auto-zoom mode to maintain a constant head and shoulders subject size within the frame, even though the distance to the subject may vary.

**1** Press the SUBJECT button until  is displayed on the LCD panel.

**2** Press the shutter release button. The lens will automatically zoom and after the appropriate subject size has been achieved the shutter will be released.

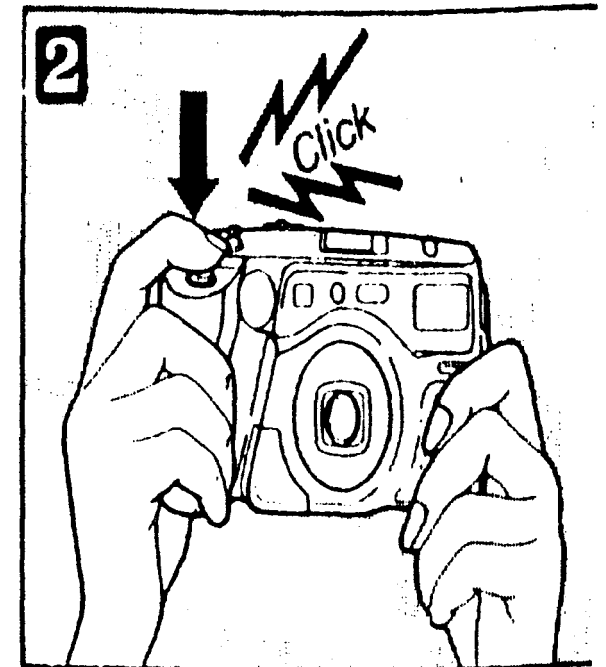
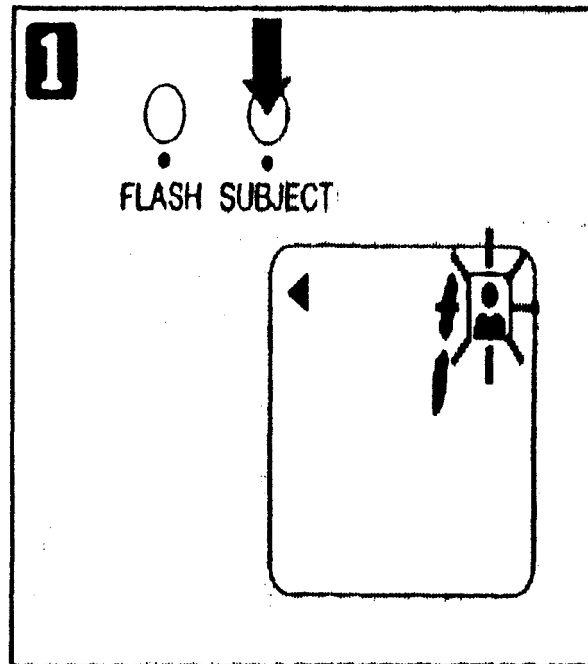

Auto-zoom mode working range: from 1.3m (4.3ft) to 3.1m (10.2ft).

\*Outside the range as shown, auto-zoom may not operate.

\*Even in the auto-zoom mode, it is possible to use the zoom buttons.

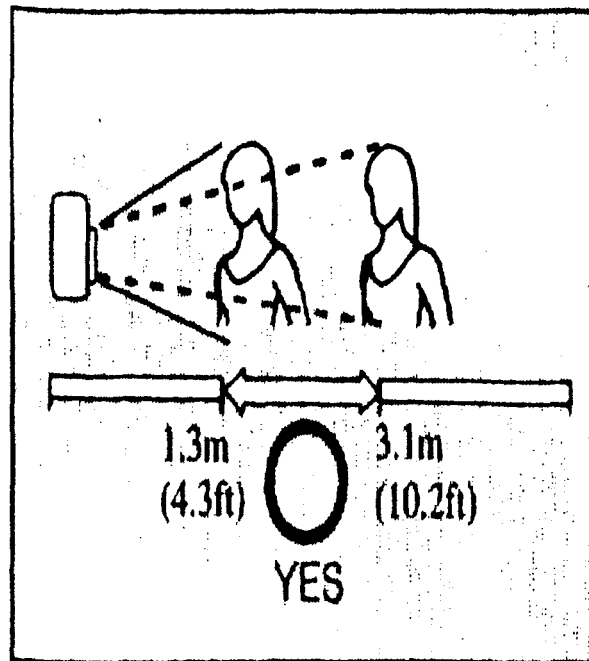

## Continuous mode

Use continuous mode to shoot a continuous series of pictures at approx. 1 frame per 1.7 seconds.

(1 frame per approx. 2.5 seconds when the flash is fired.)

**1** Press the SUBJECT button until "C" is displayed on the LCD panel.

**2** The camera will shoot repeatedly as long as the shutter release button pressed. If the subject gets closer than 0.6m (2ft) the shutter will automatically stop.

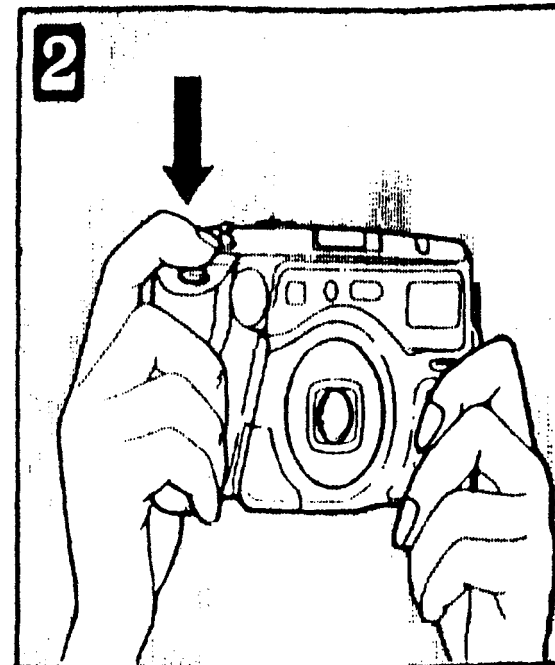
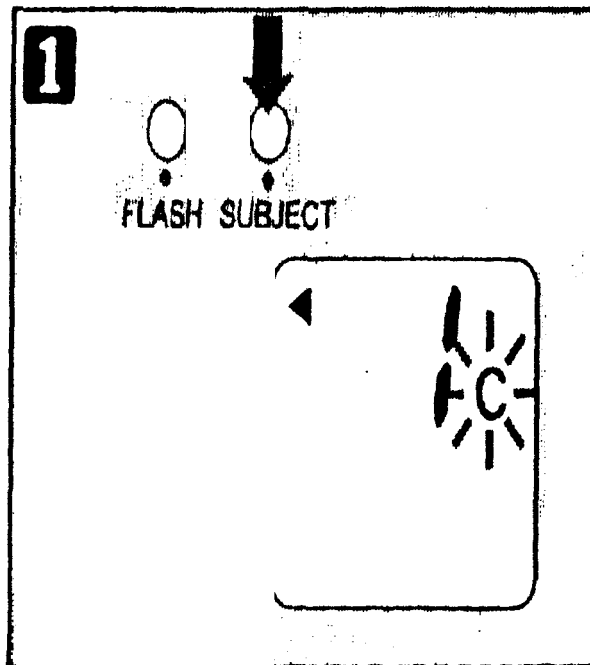

# Selftimer

**1** Set the camera firmly in position. Press the SUBJECT button until  is displayed on the LCD panel.

**2** Press the shutter release button halfway to focus.

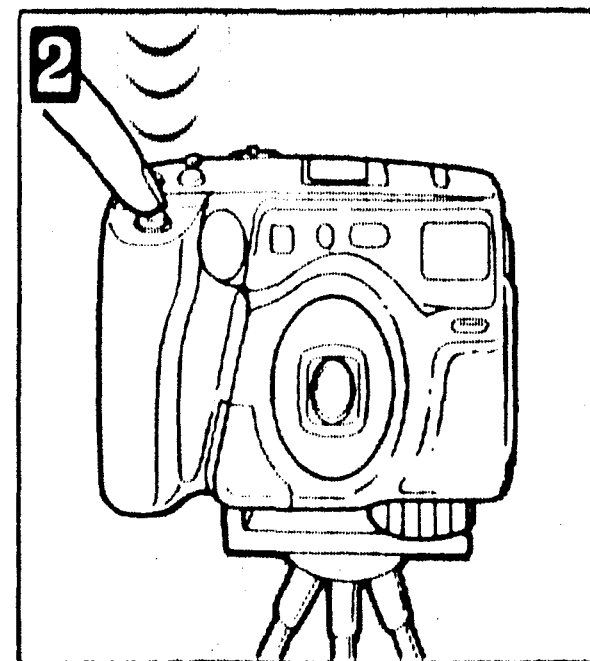
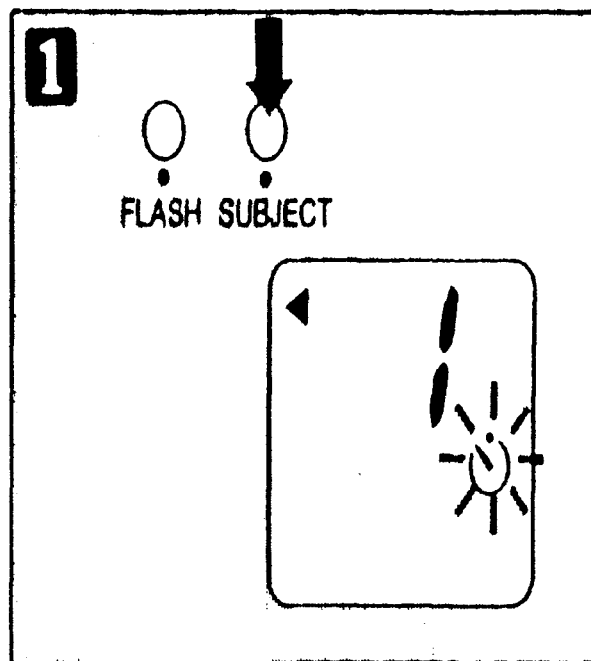

When correct focus has been achieved, the "AF" indicator (green) will light up in the viewfinder.

\*In case your subject is not in the center of the viewfinder, use the focus lock. (Refer to page 24.)

**3** Press the shutter release button fully to start the selftimer. The shutter will be released 12 seconds later. The selftimer indicator on the front of the camera will light up for the first 10 seconds, then blink rapidly for 2 seconds until the shutter is released.

\*During selftimer operation, the focus and exposure will be locked when the shutter release button is pressed.

\*To cancel the selftimer after it has been activated, press the SUBJECT button or set the power switch OFF.

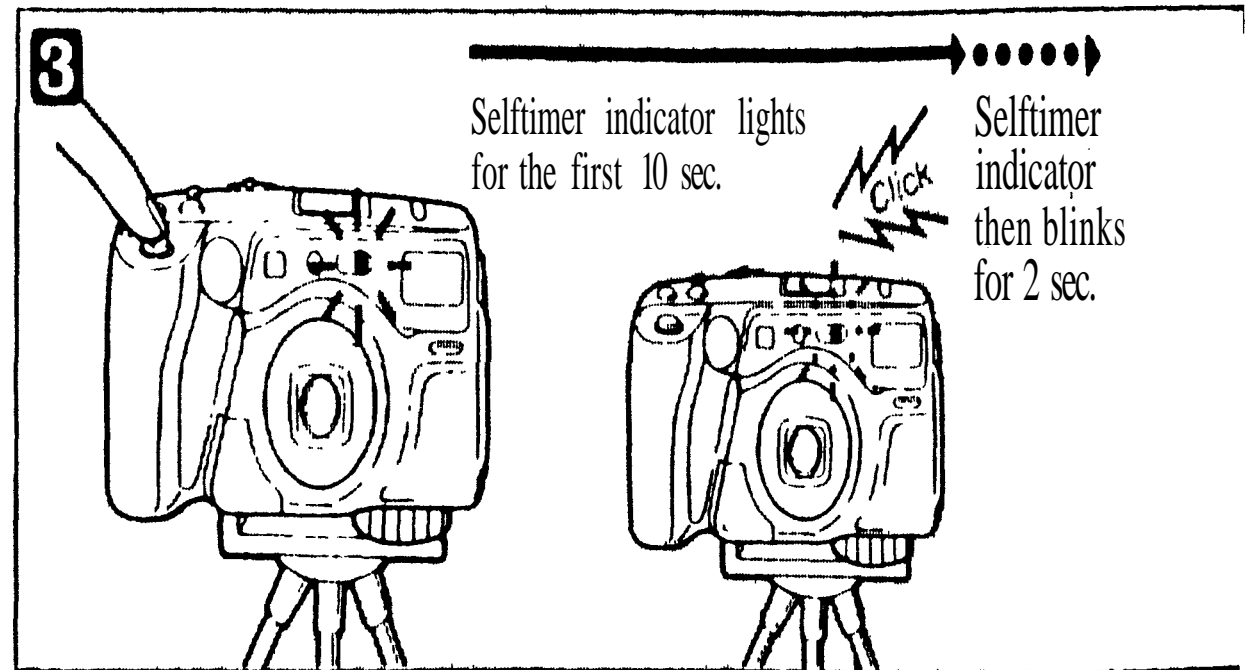
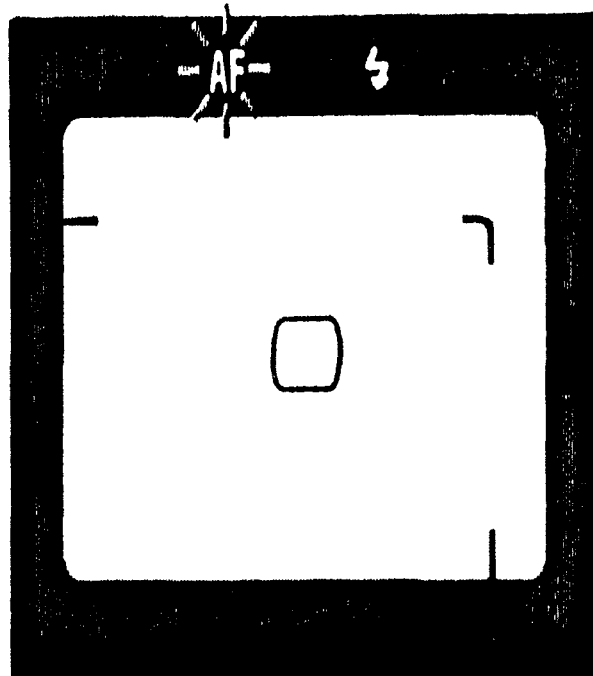



## AUTO-S flash photography

AUTO-S flash significantly reduces "red-eye" phenomenon (when a subject's eyes appear red) in flash portraits and group photos. Red-eye phenomenon is most likely to occur in very low light, and at longer focal lengths (telephoto).

Press the FLASH button to set the mode to AUTO-S.  
Compose your shot and press the shutter release button. The flash will emit a rapid series of low power pre-flashes, followed directly by the main flash.

\*Hold the camera firmly while pressing the shutter release button.  
\*AUTO-S mode will not be canceled when power is switched OFF.  
To cancel AUTO-S mode, press the FLASH button.

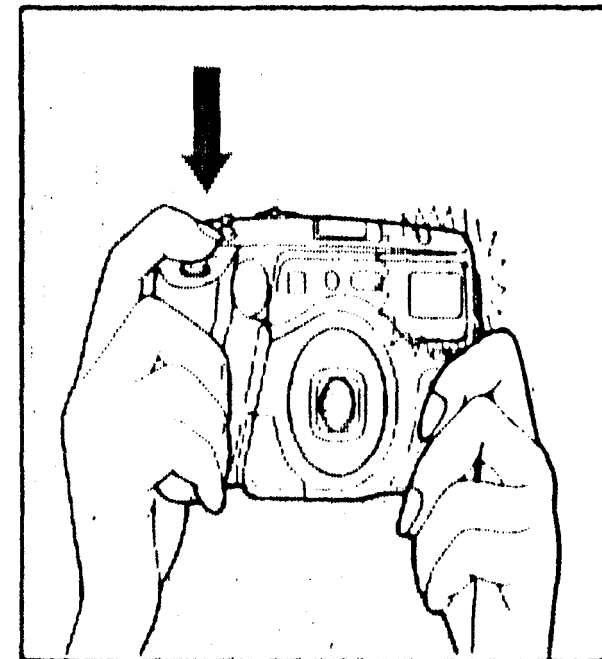
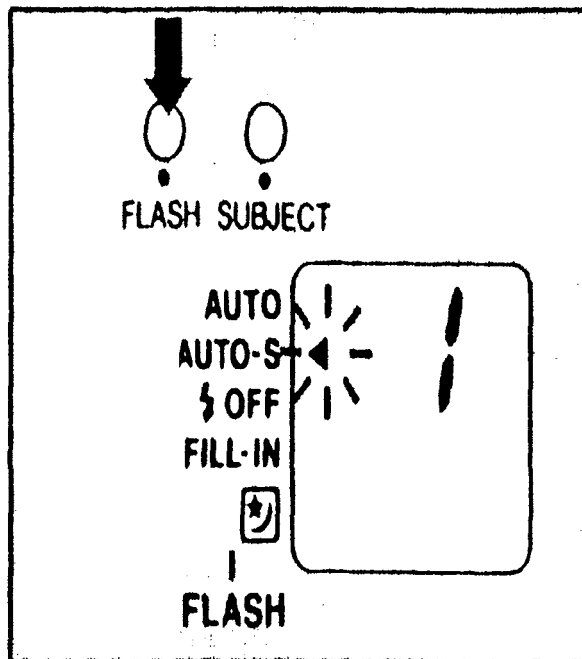

\*In the super macro mode, AUTO-S mode will be canceled and the flash mode will be reset to AUTO.

AUTO-S flash mode working range:

	WIDE(38mm)	TELE(90mm)
ISO 100	0.6—4.3m (2—14.1ft)	0.6—2.7m (2—8.9ft)
ISO 200	0.6—6.1m (2—20ft)	0.6—3.8m (2—12.5ft)
ISO 400	0.6—8.6m (2—28.2ft)	0.6—5.4m (2—17.7ft)

## Flash OFF

Use this mode for photography utilizing available light, in situations where flash photography is prohibited or when you don't want the flash to fire, such as for a night scene.

Press the FLASH button to set the flash mode to  OFF.

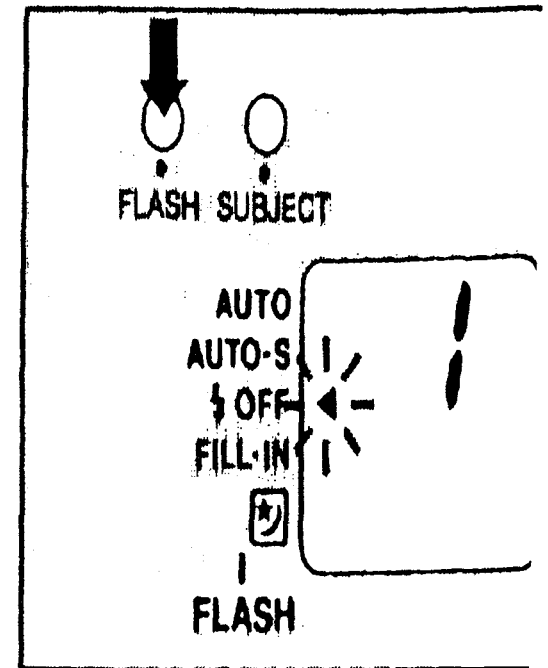

\*In low light conditions, the necessary shutter speed may be very slow (up to 2 seconds) to attain proper exposure. To prevent blurred pictures resulting from camera shake, the camera should be set firmly in position (with a tripod for example).

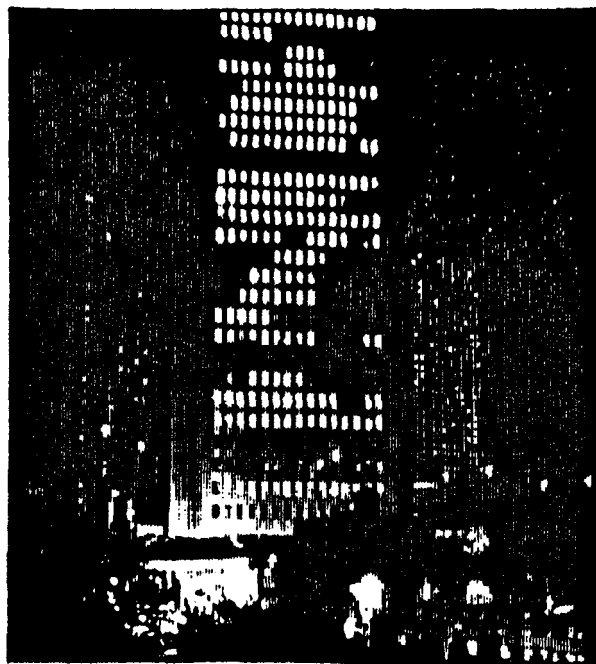

## FILL-IN flash

In this mode, the flash always fires regardless of available light. Use this mode for daylight shooting in backlit conditions to compensate for backlighting which may make the subject appear too dark.



By using the FILL-IN mode, the subject will be properly lit by the flash.

Press the FLASH button to set the flash mode to FILL-IN.

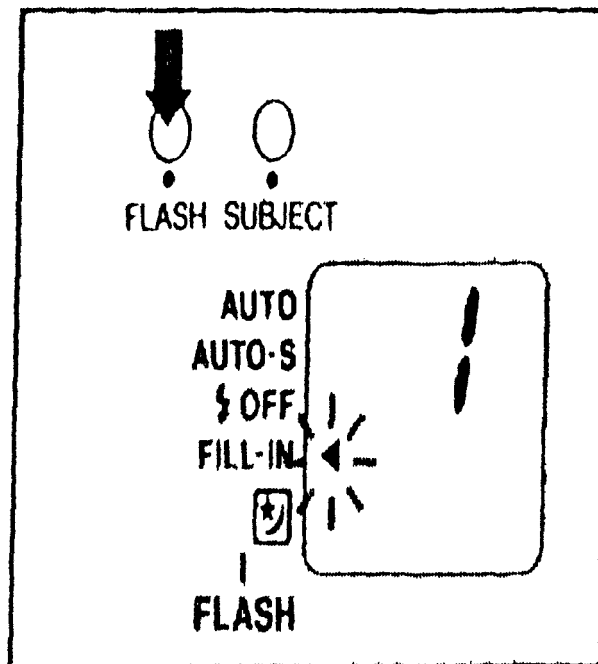

## Night scene flash photography

Use the night scene flash to capture dimly lit backgrounds, such as the sky at dusk, while properly lighting the foreground with flash.

Press the FLASH button to set the flash mode to .

\*In the night scene flash mode the necessary shutter speed may be very slow (up to 2 seconds) to attain proper exposure. To prevent blurred pictures resulting from camera shake, the camera should be set firmly in position (with a tripod for example).

In the flash AUTO mode, only the main subject will be properly exposed.

By using the night scene flash mode, both the subject in the foreground and the night scene in the background will be properly exposed.

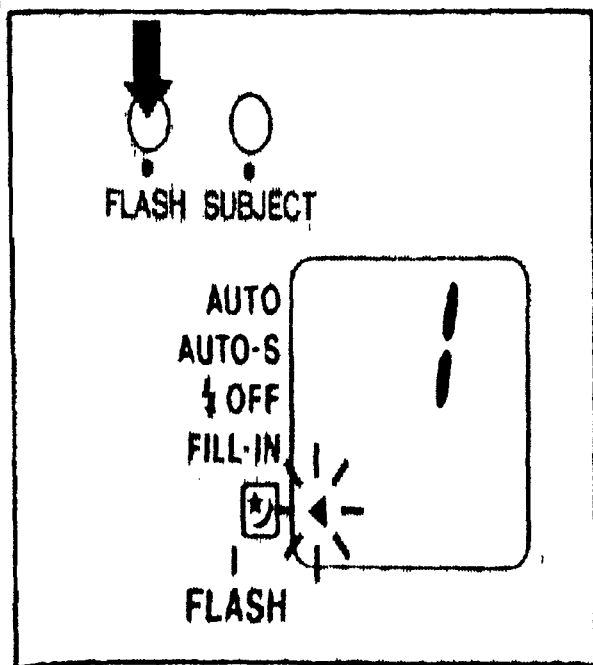

## How to use the filters (optional)

Special-effects can be obtained by using the optional Olympus filter and filter adaptor.

Olympus offers the following optional filters.

(Filter diameter: 35.5mm)

### (1) Skylight

Prevents a blue tone in color photographs taken on fair weather days and provides an overall more natural color tone.

### (2) Softon

Use this for portraits; it softens the image for more "moody" pictures.

### (3) Sunny Cross

The photograph will have rays of light around bright objects.

When the Softon is used.



When the Sunny Cross is used.

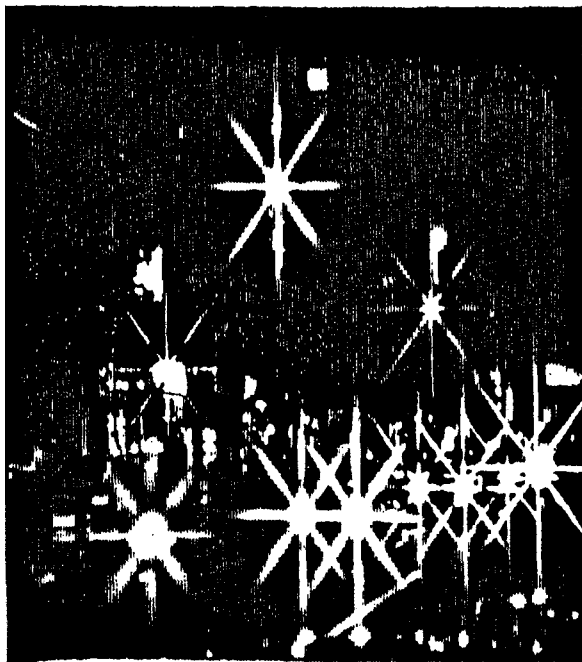

Filter adaptor (optional)



## How to use the soft case (optional)

Make sure to set the power switch OFF before the camera is inserted into the case.

❶ The camera's neck strap can be used to carry the camera after the camera is properly inserted into the soft case.

❷ The soft case can also be carried on a belt using the belt loop on the back of the case.

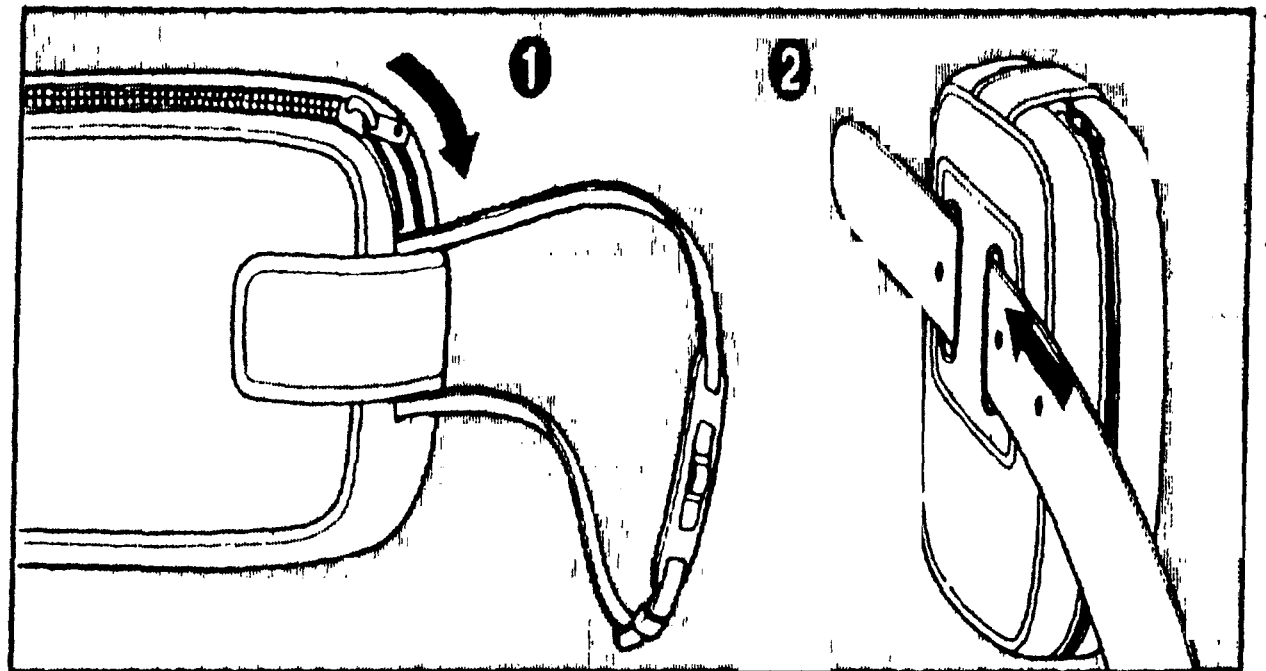



## Care and storage

- 1 Never disassemble the camera; it contains a high-voltage circuit.
- 2 Do not use thinner, benzine or organic solvents to clean the camera.

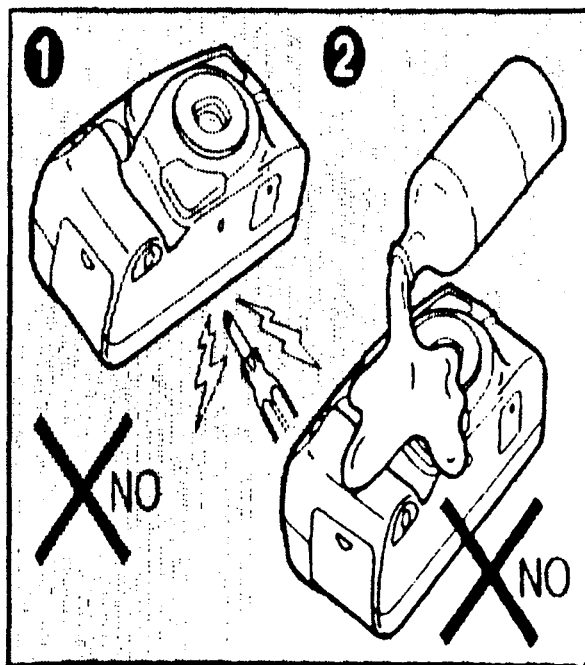

- 3 Do not touch the DX read-off contacts.
- 4 Do not disassemble or expose batteries to excessive heat.

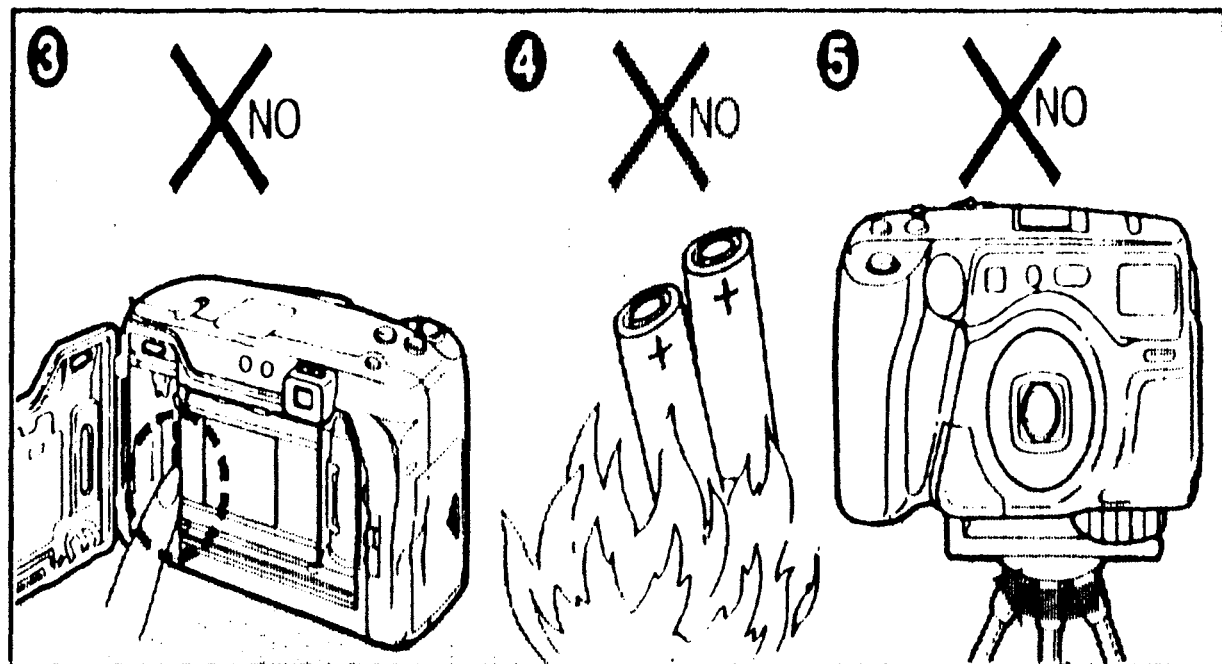

- 5 Do not rotate the camera once it is mounted on a tripod. Use the tripod swivel to vary direction. Do not open the back cover while it is mounted on a tripod.

**6** Do not expose the camera to extreme heat (over 40°C/104°F), such as inside a car during the hot summer weather, or to extreme cold (below -10°C/14°F).

**7** Do not leave the camera near magnetic fields, like on top of a TV set, or radio. In case of malfunction, take the camera to your nearest Olympus dealer or service center.

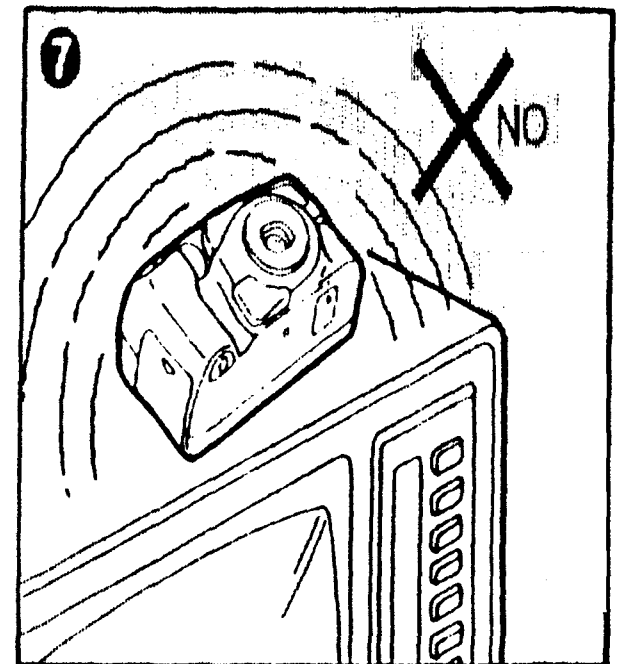
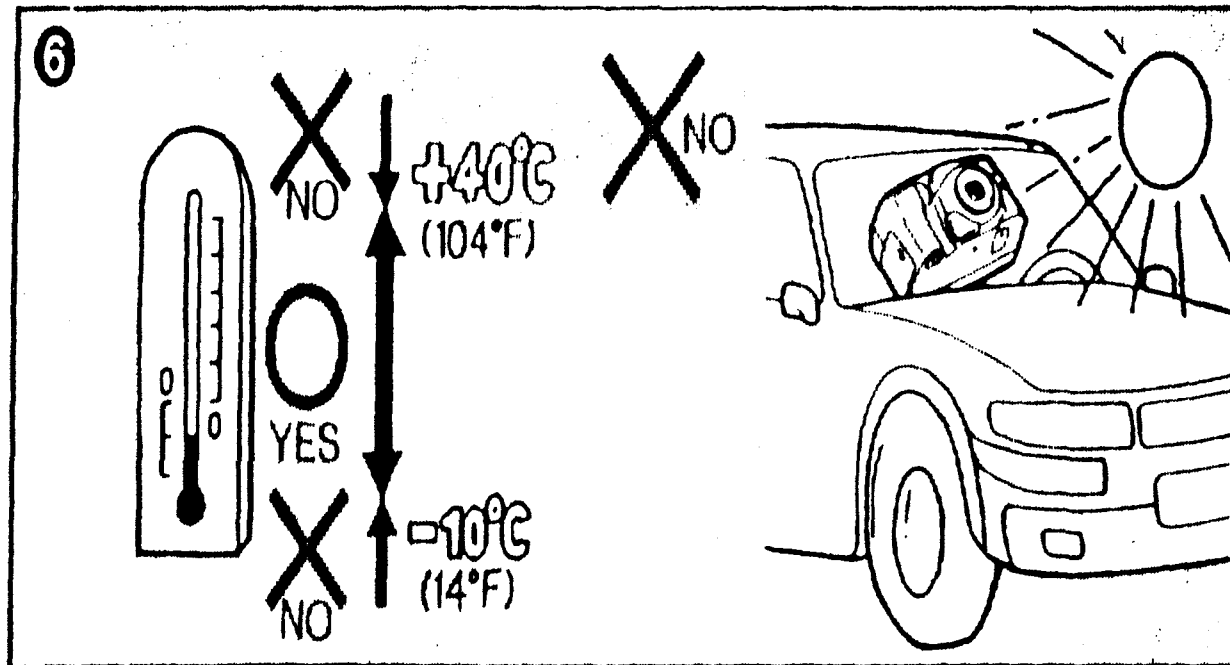

# Questions and answers

## **Q: What kind of batteries should I use?**

A: Use two 3V lithium batteries (DL123A or CR123A). Do not mix new and old batteries at the same time. Change them both at the same time.

## **Q: How long will the battery last?**

A: If you use 24-exposure rolls of film and expose half of all your pictures with flash, two new 3V lithium batteries (DL123A/CR123A) will allow you to take 30 or more rolls of film. If you do not use flash and zoom so often, the batteries will last much longer.

## **Q: The camera does not operate. What should I do?**

A: (1) Make sure the power switch is ON. (2) Make sure there are batteries in the camera, and that they are inserted correctly. (Refer to page 6.) (3) If the film has been rewound, the camera will not operate until the back cover is opened. (4) While the flash is being charged, the shutter will not release. (5) If the

distance range to the subject is less than 0.6m in normal shooting mode, the shutter will not release.

## **Q: The camera does not focus correctly. What should I do?**

A: In the following situations, the camera's autofocus mechanism may not function properly. Compose your picture by focusing on a different subject which is in the same range as your subject. (Refer to page 24.)

- ❶ Objects that reflect too much light
- ❷ Black objects
- ❸ Pictures taken through a glass window or wire screening
- ❹ Pictures including flames or smoke
- ❺ When the sun is included in the picture

## **Q: The flash does not fire.**

A: (1) Make sure the flash mode is not set to OFF mode. (2) When the flash is fired too often continuously, flash charging will take longer, and the flash may not fire. Wait until the  indicator lights up in the viewfinder.

**Q: The camera fails to operate in cold weather. What can I do?**

A: Generally, low temperatures will reduce the battery performance temporarily. Try to keep the camera warm before using them.

**Q: The remote control does not operate.**

A: Due to the noise produced by specific types of fluorescent lighting (fluorescent lights without glow lamp), it may not be possible to use the remote control unit. In such cases, use the selftimer.

# Specifications

**Type:** Full-automatic 35mm autofocus lens-shutter camera with built-in 38—90 mm zoom lens.

**Film format:** 35mm standard DX coded film (24 × 36mm)

**Lens:** Olympus lens 38 — 90mm F4.5—7.2, 7 elements in 7 groups.

**Shutter:** Programmed electronic shutter.

**Viewfinder:** Kepler type zoom-finder (with autofocus frame, close-up correction marks, autofocus indicator and flash indicator).

Dioptric correction possible (-2—+1 diop.).

**Focusing:** Active type autofocus system, focus lock possible.

Focusing range: 0.6m (2ft) — ∞ (infinity).

0.4m (1.3ft) (in super macro mode).

**Exposure control:** Programmed automatic exposure control.

Center-weighted average light metering, switchable to spot metering.

Auto exposure range:

Wide-angle: EV 3.3 (F4.5, 2 sec.) to EV16 (F11, 1/500 sec.)

Telephoto: EV4.7 (F7.2, 2 sec.) to EV17 (F16, 1/500 sec.).

**Exposure counter:** Progressive type with automatic reset, displayed on LCD panel.

**Selftimer:** Electronic selftimer with 12 sec. delay.

**Film speed range:** Automatic setting with DX coded film ISO 50 — 3200 (color negative film). Actual setting points at ISO 50, 100, 200, 400, 800, 1600, 3200.

For non-DX coded film, film speed is set to ISO 100.

**Film loading:** Automatic loading (automatically advances to first frame when camera back is closed).

**Film advance:** Automatic film winding.

**Film rewind:** Automatic film rewind (automatic rewind activation at end of film, automatic rewind stop). Rewind possible at any point with rewind button.

**Flash:** Built-in flash.

Recycling time: approx 0.2—3.5 sec. (at normal temperature with new batteries).

Flash working range (ISO 100 color negative film):

Wide-angle: 0.6m—4.3m (2ft—14.1ft),

Telephoto: 0.6m—2.7m (2ft—8.9ft)

Flash working range (ISO 400 color negative film):

Wide-angle: 0.6m—8.6m (2ft—28.2ft),

Telephoto: 0.6m—5.4m (2ft—17.7ft)

**Flash modes:**

AUTO (Automatic flash activation in low light and backlight)

AUTO-S (Red-eye reducing, in low light and backlight)

⚡ OFF (No flash)

FILL-IN (Forced activation)

53  (For night scene, automatic flash activation in low light.)

**Battery check:** Displayed on LCD panel

**Power source:** Two 3V lithium batteries (DL123A/CR123A)

**Dimensions:** 137(W) × 72(H) × 61(D)mm

$(5\frac{3}{8} \times 2\frac{13}{16} \times 2\frac{3}{8} \text{ in.})$

**Weight:** 385g (13.6oz) (without batteries).

**Remote control:** Wireless remote control unit with 1-second and 3-second delay time.

\*Specifications and design are subject to change without notice.

# OLYMPUS®

## **OLYMPUS OPTICAL CO., LTD.**

San-Ei Building, 22-2, Nishi Shinjuku 1-chome, Shinjuku-ku, Tokyo, Japan. Tel. 03-3340-2211

## **OLYMPUS CORPORATION**

Crossways Park, Woodbury, New York 11797-2087, U.S.A. Tel. 516-364-3000

## **OLYMPUS OPTICAL CO. (EUROPA) GMBH**

Postfach 104908, Wendenstrasse 14-16, 2000 Hamburg 1, Germany. Tel. 040-23773-0

## **OLYMPUS OPTICAL CO. (UK) LTD.**

2-8 Honduras Street, London EC1Y 0TX, England. Tel. 01-253-2772

PRINTED IN JAPAN 0591. 10MM

## Free Manuals Download Website

<http://myh66.com>

<http://usermanuals.us>

<http://www.somanuals.com>

<http://www.4manuals.cc>

<http://www.manual-lib.com>

<http://www.404manual.com>

<http://www.luxmanual.com>

<http://aubethermostatmanual.com>

Golf course search by state

<http://golfingnear.com>

Email search by domain

<http://emailbydomain.com>

Auto manuals search

<http://auto.somanuals.com>

TV manuals search

<http://tv.somanuals.com>