

OLYMPUS[®]

Your Vision, Our Future

CONFOCAL LASER SCANNING
MICROSCOPE

LEXT[™]

OLS3100

NEW

3D

Welcome to the world of LEXT 3D

OLYMPUS

LEXT

LASER

POWER

The name "LEXT" is formed from the words "Laser" and "Next," and means "next-generation 3D confocal laser microscopes".

Download from Www.Somanuals.com. All Manuals Search And Download.



O n e C l

Greater simplicity with higher precision: The next step in the evolution of three dimensional laser confocal metrology.

LEXT minimizes manual operation, improving ease of use for everyone.

Even a first-time user can operate the system like an expert, and obtain fast reliable measurement results.

The system features not only improved functionality, but also an even higher level of measurement performance.

Constantly evolving toward greater simplicity and higher precision,

LEXT meets a diverse range of needs in fine surface profile measurement.

Welcome to the world of LEXT 3D

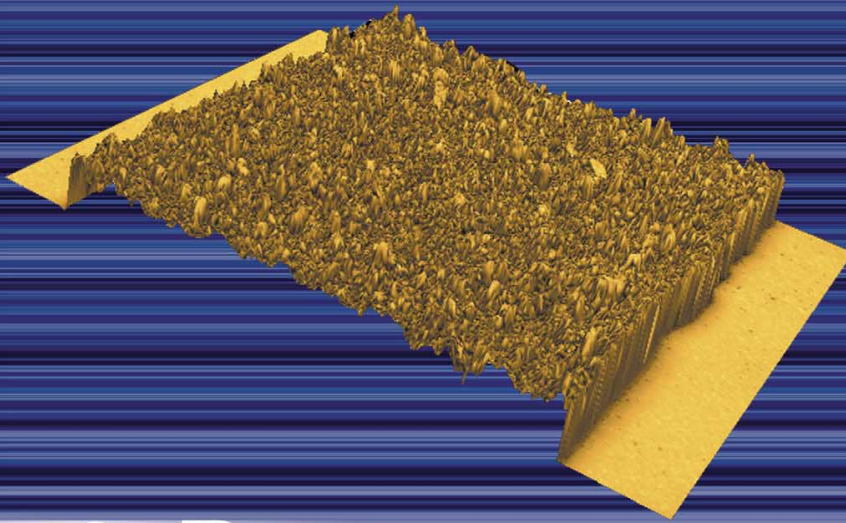

ick 3D



Easy Operation

Automatic operation achieves speedy, high-precision output.

Position and magnification settings ▶

1 Click ▶

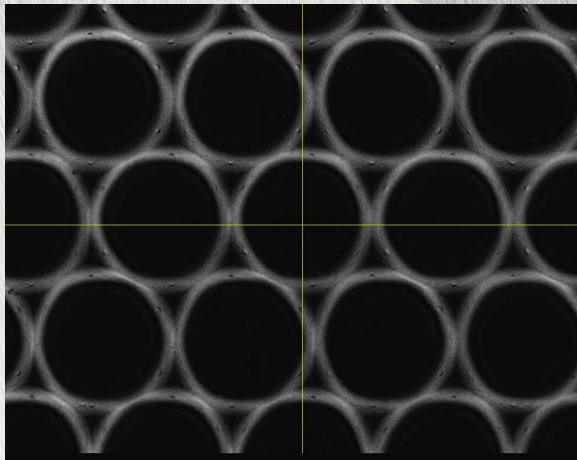

New, Operation Navigator feature is an online wizard that guides the user in the operation of the LEXT

The operation navigator provides animations to guide the user through each step of microscopic observation. You can complete a series of steps by simply operating the mouse in the same way as shown in the animations appearing on the screen.



3D image capturing with one click automatically detecting upper and lower limits

With LEXT, 3D image capturing is performed by just one click of the "3D capture button." Upper- and lower-limit settings or other cumbersome preparations are unnecessary. A beginner can obtain a 3D image of the best quality easily. For experienced users, this automated 3D image capturing feature lightens their work load and contributes greatly to increasing their work efficiency.

The motorized, high-speed revolving nosepiece ensures the safe and speedy microscopic inspections

Motorized switching between magnifications helps the user to increase work efficiency and to keep the specimen safe; an automatic retracting function prevents an objective lens from coming contact with a specimen. It also offers excellent parfocality of all objective lenses and an automatic light intensity adjusting function keeps brightness levels unchanged after magnification switching.



High-speed automatic focusing and one-push gain enable the user to complete preparations for 3D image capturing quickly and easily

The speed of the automatic focusing function has been made three times faster so that the user can reach an image or a point on an image in an instant. Additionally, one-push gain allows the user to adjust brightness optimally and to complete preparations for 3D image capturing with ease.

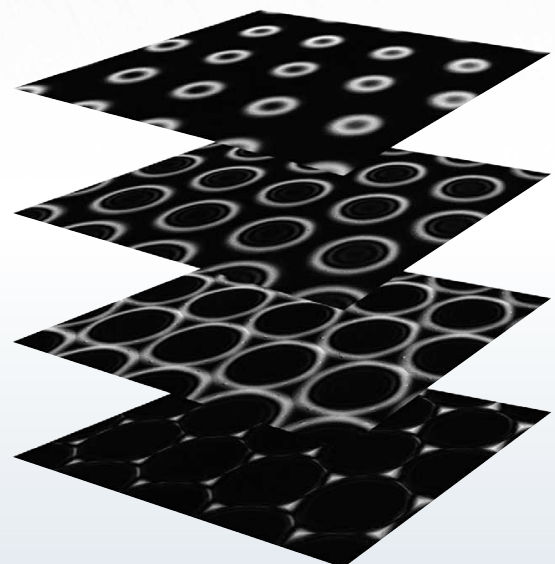
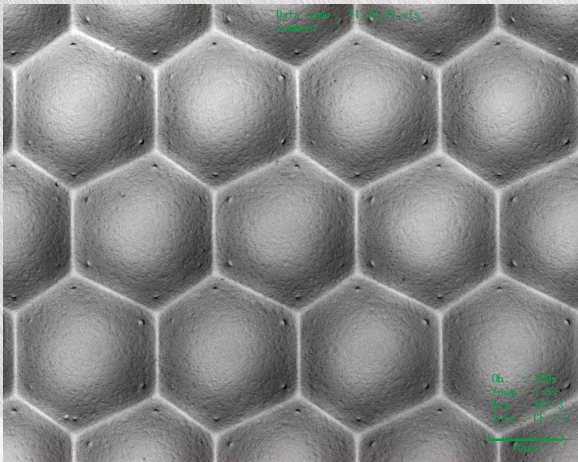

Image capturing



Microlens

Auto Fine View does it all automatically

The brightness and contrast of a captured image are automatically adjusted. Image conditioning is typically a manual process requiring an experienced operator. Using the auto fine view function of LEXT, anybody can acquire ideal, high-quality 3D images without special training.

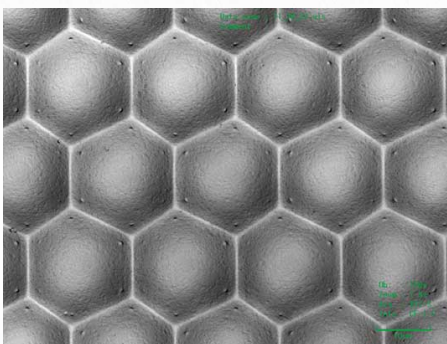

After auto processing

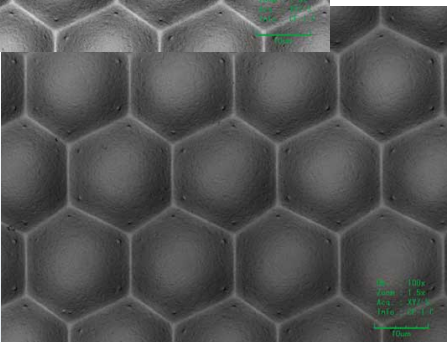

Before processing

Display, measurement and analysis

Introducing the user to a new 3D world by providing a variety of image presentation patterns, high precision measurement and advanced analytical techniques

A captured image is rendered to an ideal 3D image by using LEXT's display capabilities. High precise measurement, high repeatability, and advanced analytical techniques related to roughness and particle analyses provide the user with a new dimension of microscopic observation.

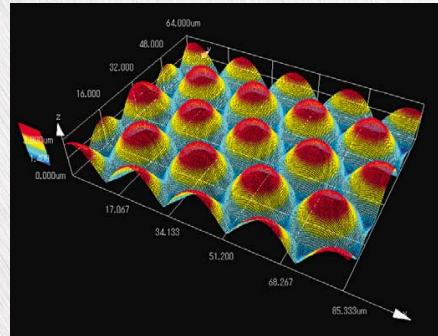

Wired frame

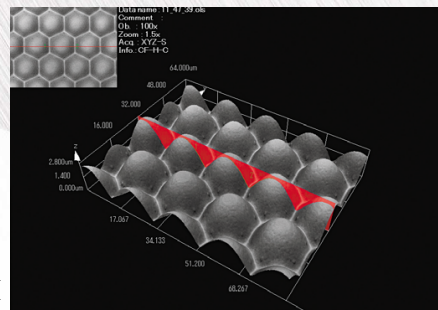

Step height measurement

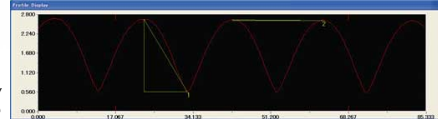
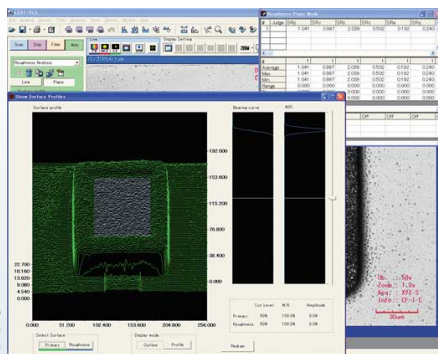

Image intensity profile



Surface roughness analysis

Wafer bump

3D images processing

Powerful 3D display facilitates measurement and analysis.

Display

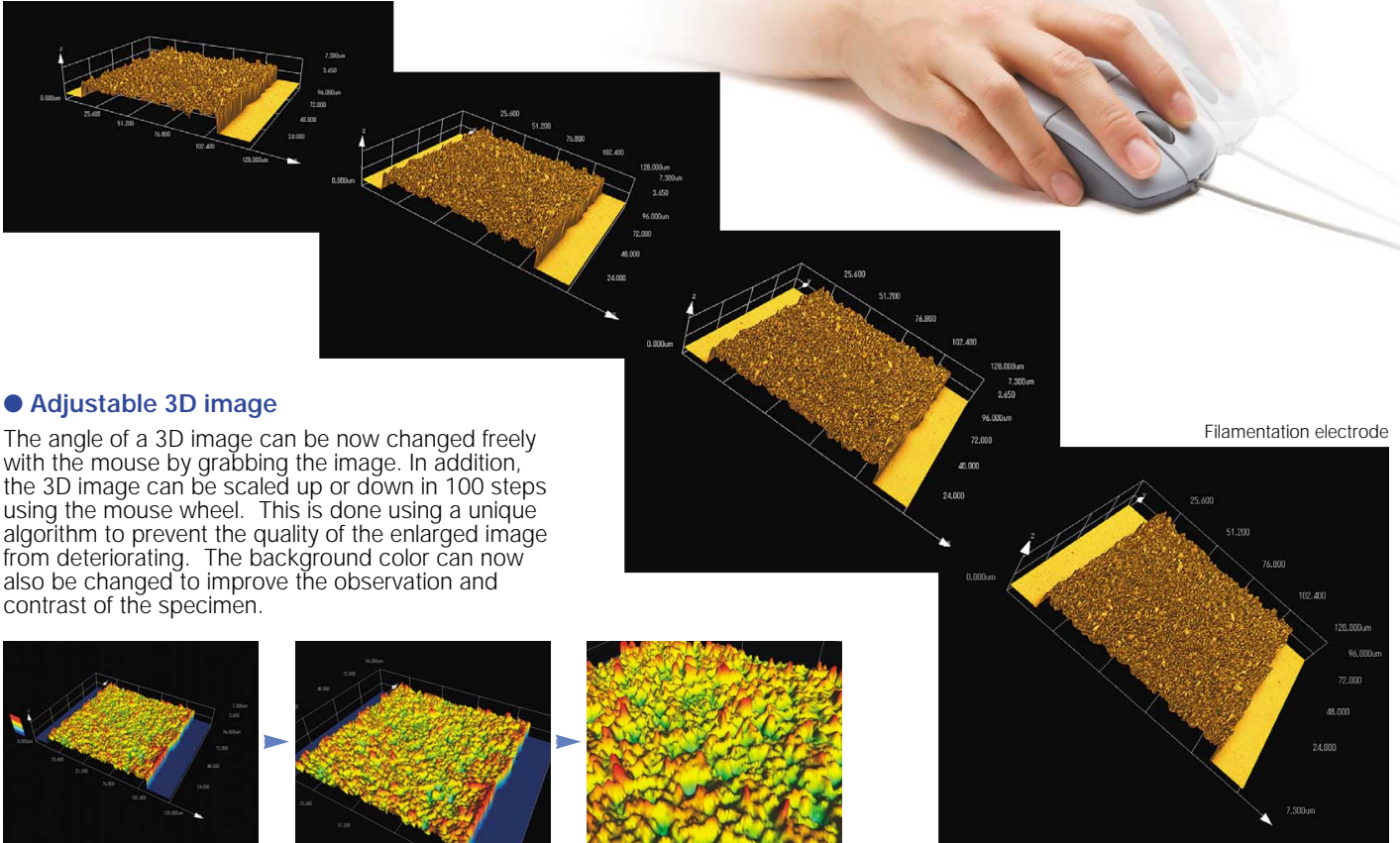

● Adjustable 3D image

The angle of a 3D image can be now changed freely with the mouse by grabbing the image. In addition, the 3D image can be scaled up or down in 100 steps using the mouse wheel. This is done using a unique algorithm to prevent the quality of the enlarged image from deteriorating. The background color can now also be changed to improve the observation and contrast of the specimen.

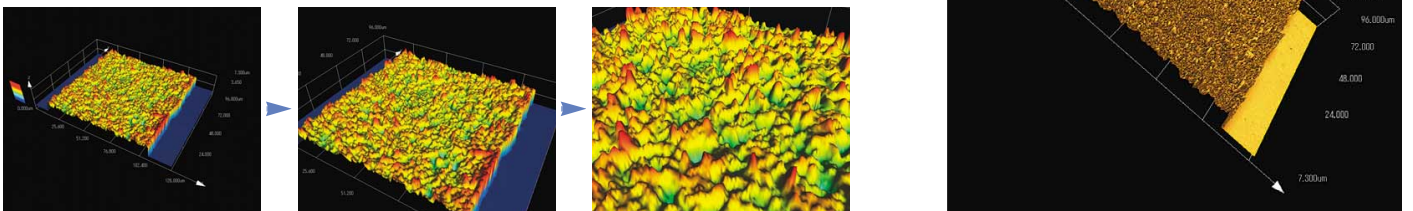

Measurement

● 3D measurement

Step height, line width and the distance between two points can now be measured on the 3D image. Allowing measurement conditions to be recognized intuitively.

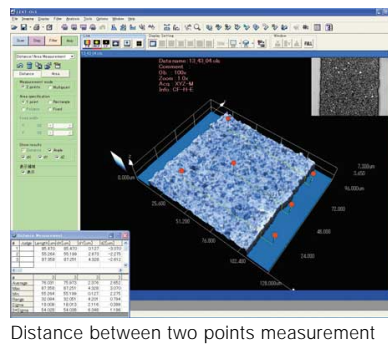

Distance between two points measurement

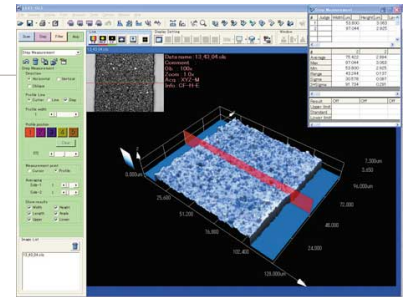

Step height measurement

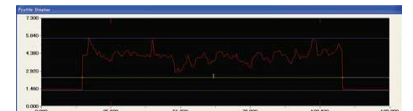

Line width measurement

● A variety of 3D image presentation patterns

A variety of 3D image presentation patterns are provided, including surface texture, real color, wired frame, etc. A 3D image can be rendered to make it more visually effective.

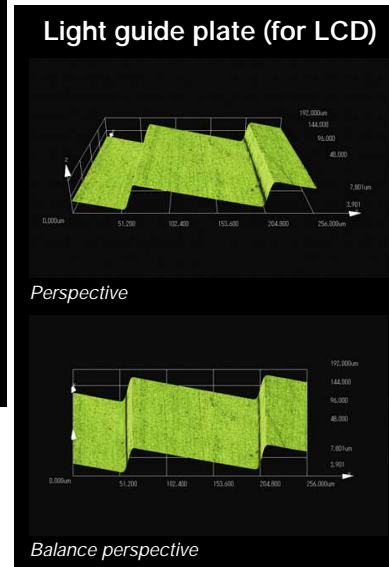
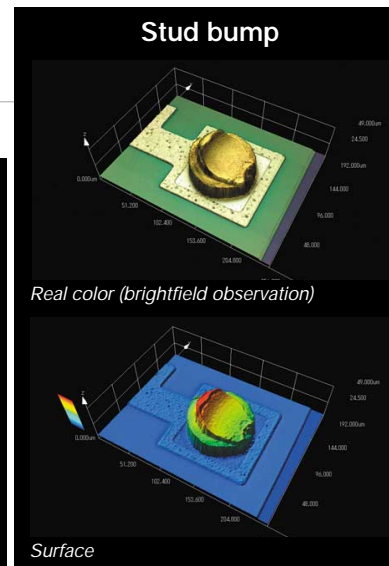
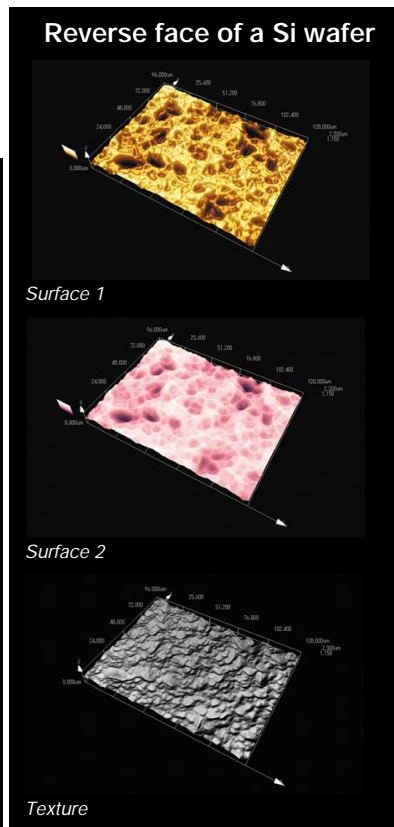
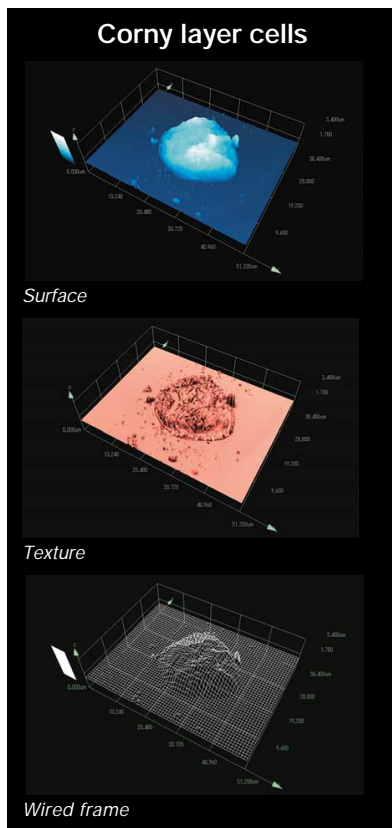

● Surface roughness analysis

Non-contact surface roughness measurement can be gathered using the small laser spot. Further minute roughness analysis can be made using the unique ROI function. Roughness can also be made along a single line much like conventional roughness gauges.

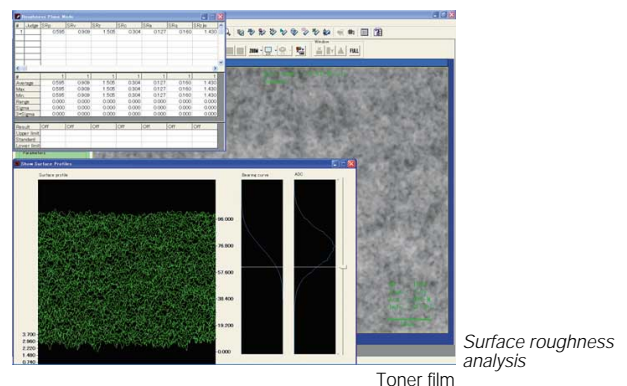

2D images processing

Versatile observation methods to handle a wide range of applic

Display

● Brightfield observation

Color information can be obtained from brightfield (color) observation. Therefore, brightfield observation can be used effectively to observe a flaw on a color filter or to locate the position of an area of corrosion on metal.



Laser printer toner

● DIC (Differential Interference Contrast) observation

In DIC observation, it is possible to observe a scratch or flaw as small as a few nanometers in height that could not be observed in a brightfield observation.

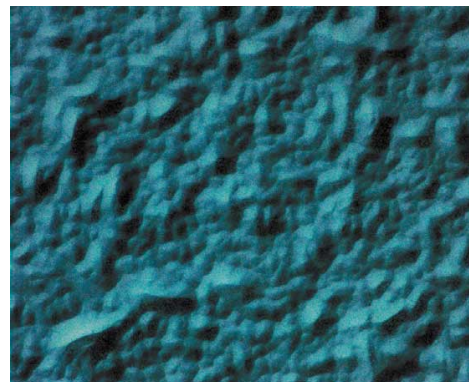

Reverse face of a wafer

● Laser confocal

Observation with a much higher level of resolution impracticable with conventional microscopes is now possible through a combination of a 408 nm laser and confocal optics.

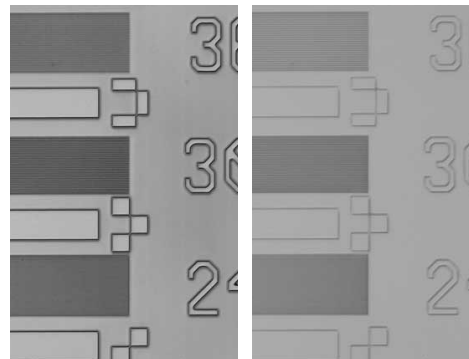

Confocal image

Non confocal image

Circuits patterns on wafer

● Laser confocal DIC

Microscopic unevenness on a surface can be observed in three dimensions in real time, which is impossible with conventional laser microscopes. Observation of surface conditions with the level of dimensional reality comparable to that of an SEM has been made fully possible, opening up a new dimension in surface profile observation.

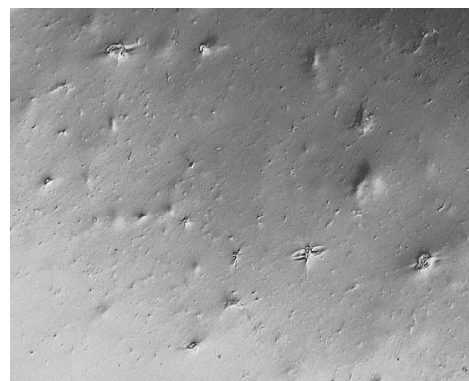

Polymeric film

ations.

● Split screen display

An image observed in one observation mode and the same image observed in another observation mode can be displayed simultaneously during live observation. A target point can be located easily by observing a microscopic image with color information and a high-resolution LSM (Laser Scanning Microscope) image simultaneously. By using this two-screen display function, the quality of a specimen can be checked by comparing it with a reference specimen in live observation, and whether it is acceptable or not can be determined.

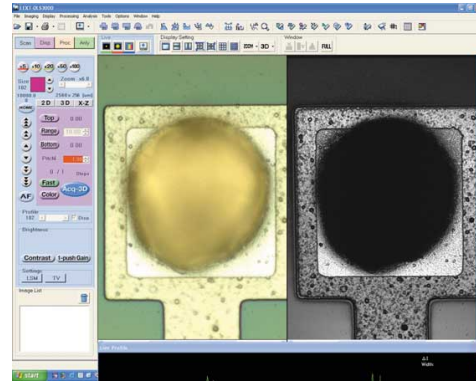

Stud bump



● Real-time distance measurement

A distance can be measured in real time by using image intensity profile. A distance can be measured in live observation.

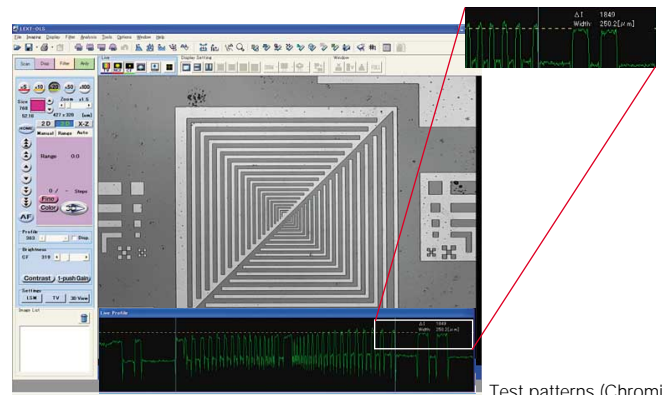

Test patterns (Chromium)



● Particle analysis

Particles can be automatically separated using the separator function, threshold values can be set, and the range of detection can be specified. Automatic measurement of all particles can be made using various particle measurement parameters, and measured data can be statistically processed to support advanced particle analyses.

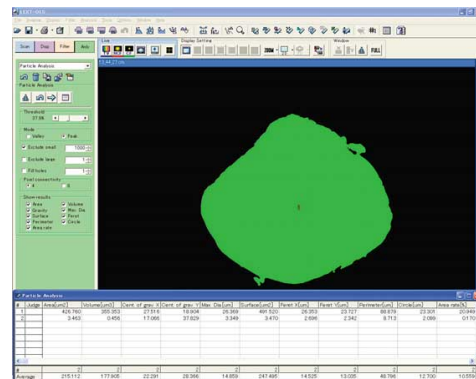

Cornly layer cells

World-class resolution and precision.

● World's highest level of resolution

The optical system designed exclusively for use with 408-nm laser light (violet opt system) prevents the occurrence of aberrations associated with the use of a short-wavelength light source, and brings the highest performance out of the 408-nm light source. Such a high level of resolution has been made possible by the confocal optical system having an optimized circular pinhole and the high-speed XY scanner with the MEMS technology of Olympus. With the world's highest-level planar resolution, a line or space of 0.12 μm can be resolved. Additionally, the 0.01 μm height resolution supports the user in undertaking measurements of microscopic surface profiles.

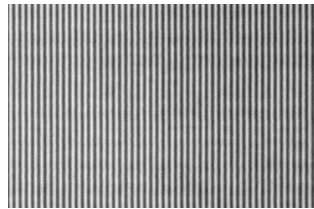

0.12 μm line and space 14,400x

Basic concept of the two-dimensional scanner

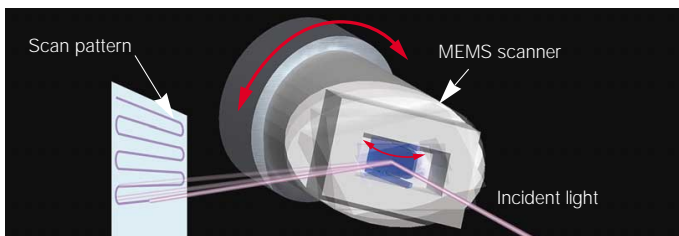

Basic concept of a light path in the violet opt system

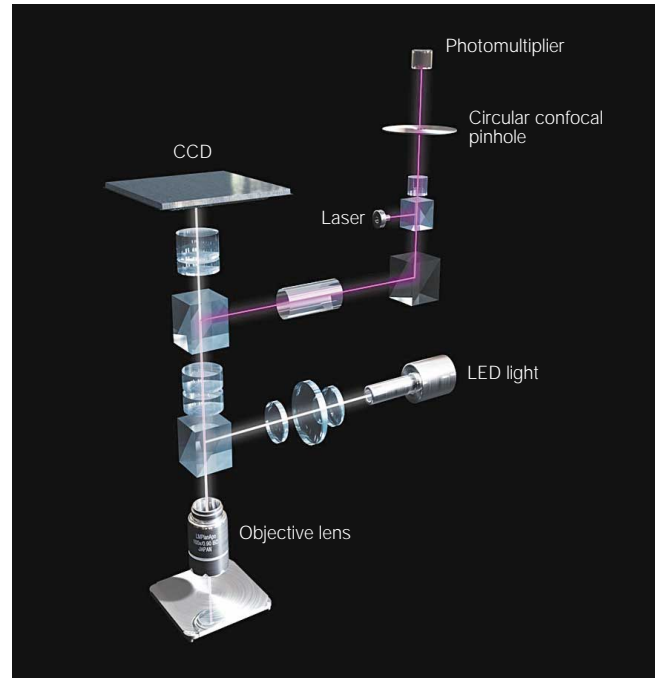

● Further advanced, the world's highest level of repeatability

Advanced optical techniques of Olympus accumulated over years have made possible the planar measurement repeatability of $3\sigma = 0.02 \mu\text{m}$ and the height measurement repeatability of $3\sigma = 0.04 + 0.002L \text{ mm}$ (L = measured length in μm). A guide with high performance in terms of straightness and a high-precision linear scale are used for Z-axis scanning. These parts combined with the further advanced CFO search function contribute to very high level of repeatability. The high degree of reliability makes it possible for LEXT to meet the highly demanding needs of diverse fields of research and industry.

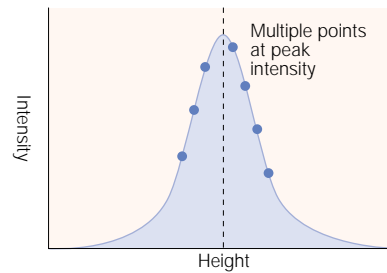

CFO search function

The original I-Z curve is drawn based on the upper, high-luminance points, and maximum luminance values are calculated with high accuracy by using an advanced formula. The high repeatability of LEXT is made possible through the height data being obtained in this process.

● Measurements that can be trusted

Highly reliable data can be provided based on the strict traceability system that is linked with the JCSS (Japan Calibration Service System).

Traceability chart

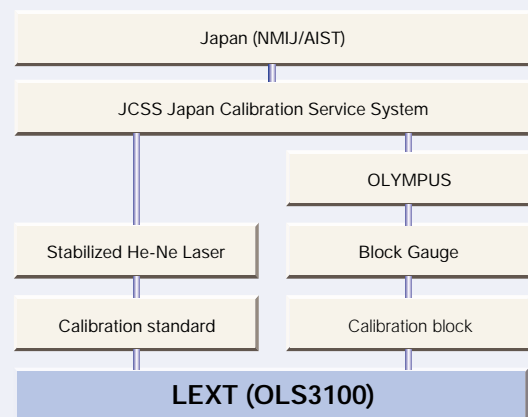

● Objective lens designed exclusively for LEXT Confocal Laser Scanning Microscope

An apochromatic objective lens exclusively for Confocal Laser Scanning Microscope, which enables to improve the optical performance with a 408-nm laser light, was developed. This special objective lens developed with the world-class optical technology of Olympus has made possible the highest level of observational clarity and measurement accuracy at high magnifications.



● 5-step sensitivity switching function

LEXT allows sensitivity to be set at each Z position (note) and an image to be captured by switching from one level of sensitivity to another. In the case of a specimen with multi-structure patterns and holes, varying reflectances pose a difficulty in measuring the height. Using this sensitivity switching function, it is possible to obtain information on optimal height and luminance for such types of specimen.

Note: Sensitivity can be set for a maximum of five Z positions.

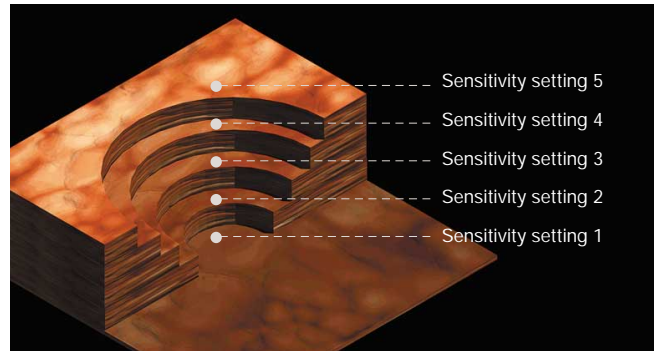

Simulations

● Enhanced mode to capture clear images of specimens with different reflectances

In the case of a conventional laser microscope, it is difficult to turn specimens with different reflectances into an image, such as the surface of a printed circuit board or copper wiring board, or an inclined plane with weak reflection. LEXT equipped with the enhanced mode allows such specimens to be turned into clear images.

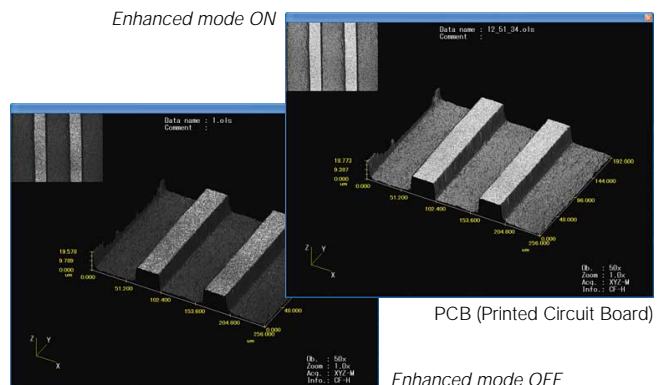

PCB (Printed Circuit Board)

Enhanced mode OFF

● ROI (Region of Interest) noise filter

Areas can be specified on the screen, and different filtering operations can be performed for each area. An ideal 3D image can be obtained.

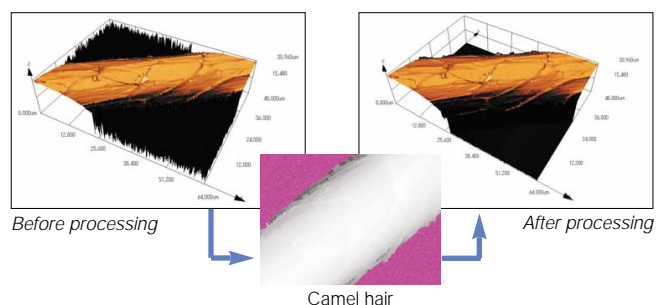

Camel hair

Applications

Full range of measurement/analysis functions to meet virtually

Spherocrystal of polyamide resin

The image shown below is a three-dimensional image of a spherocrystal of an injection molded polyamide resin (PA66) product observed using the N-ARC method. Such a spiral-shaped higher-order structure is observed in the spherocrystal growth process after injection molding, although it is of rare occurrence. LEXT with the DIC capability can capture a minute level difference of several nanometers as a clear 3D image, as shown in the image to the left.

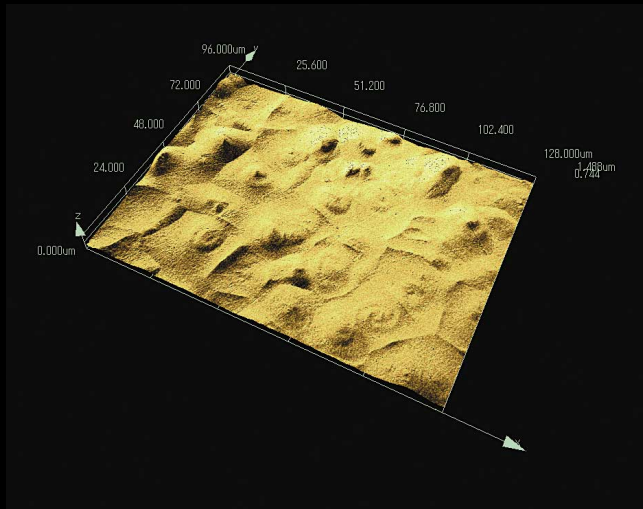

Laser confocal 3D image

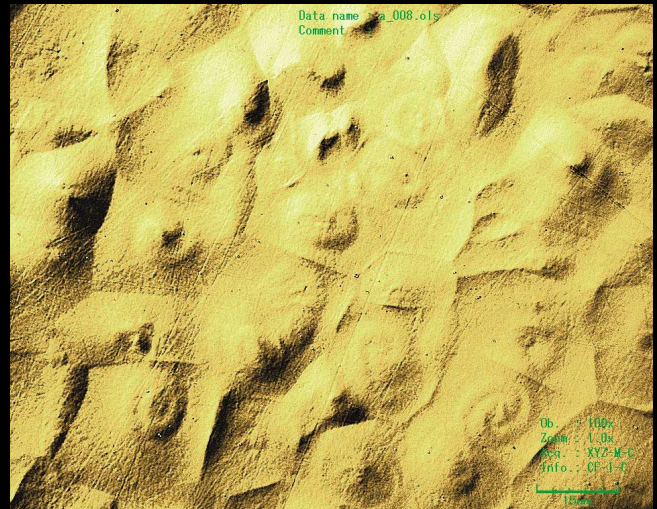

Laser confocal DIC image

Foam (fluoro rubber)

Foam made by being injected with tiny air bubbles has outstanding properties—they are heat-insulating, flexible and shock-absorbing. Therefore, such foam is widely used as the material of wet suits, as packing and weather strips, and as the material to make many other products. The size of air bubbles and how uniformly the air bubbles are distributed have a great influence on the merchantability of a foam product. The image on the left is a 3D image of a cross section cut through a piece of fluoro rubber foam in a cooled condition. By processing this image, data on the volume and area of this foam can be obtained. This type of data can be provided so that the user can use the data to identify defects in foam products, to improve production conditions, and for other purposes.

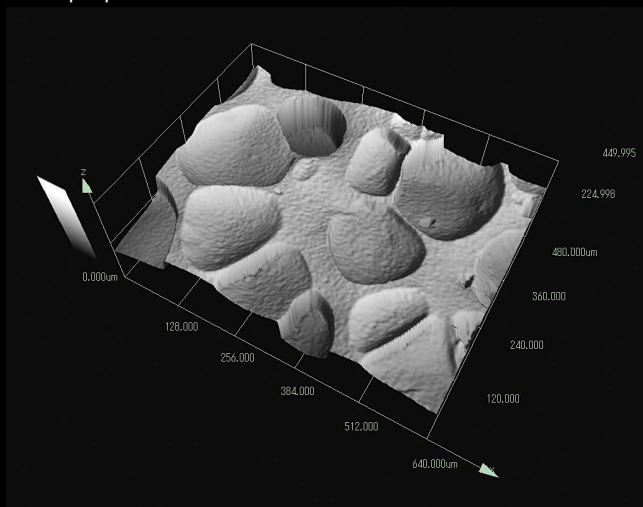

Laser confocal 3D image

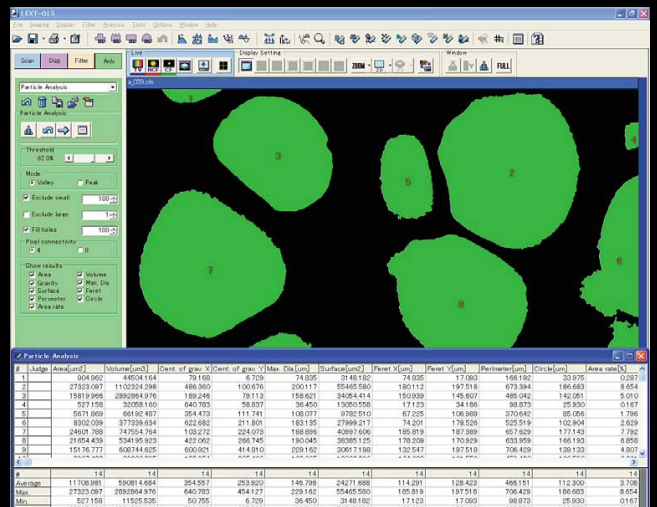

Particle analysis

any requirement.

Solder (after ion etching)

Because solder is very soft, years of experience and know-how are required to make specimen preparations before observing the composition of solder under a microscope. Polished surface techniques using the ion etching method have made considerable progress in recent years. The image shown below is the surface of solder processed with the ion etching method. This image shows that the tin (Sn) layer (white part) is made smoother by using the ion etching method. An SEM requires vapor deposition, whereas LEXT does not require pretreatment. Therefore, by using LEXT a specimen can be observed in its actual state.

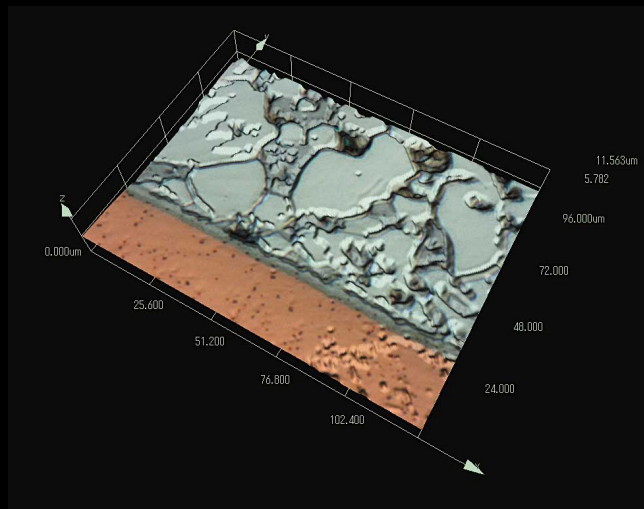

3D image in real color

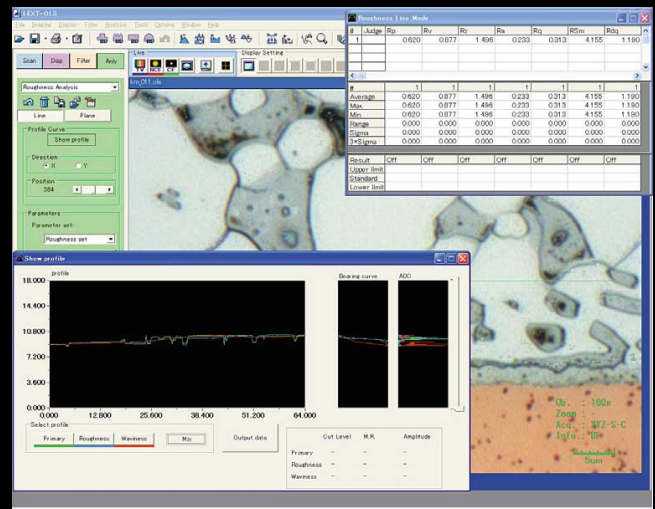

Line roughness analysis

Paper applied with an adhesive (sticky note)

Sticky notes are widely used for the convenient feature of applying, peeling and applying again. Minute spherical adhesives are distributed where an adhesive is applied to a sticky note, as shown in the image below. The way they are distributed, the thickness of an adhesive, etc., are thought to determine the ease of use (merchantability) of sticky notes. Using LEXT, such adhesives and paper (fiber) can be observed and measured without pretreatment in a noncontact manner.

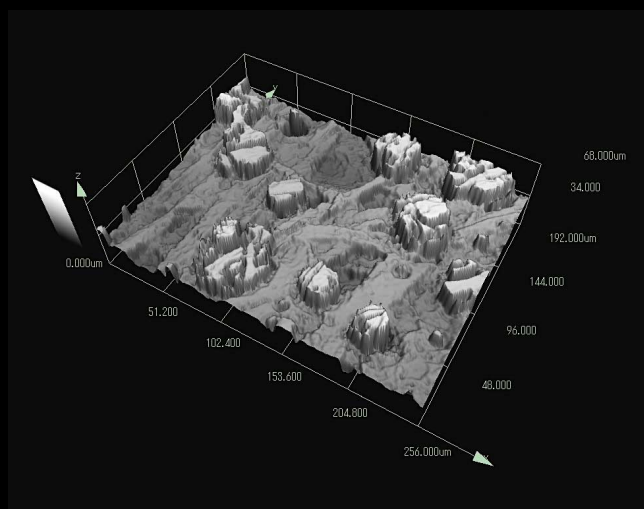

Laser confocal 3D image

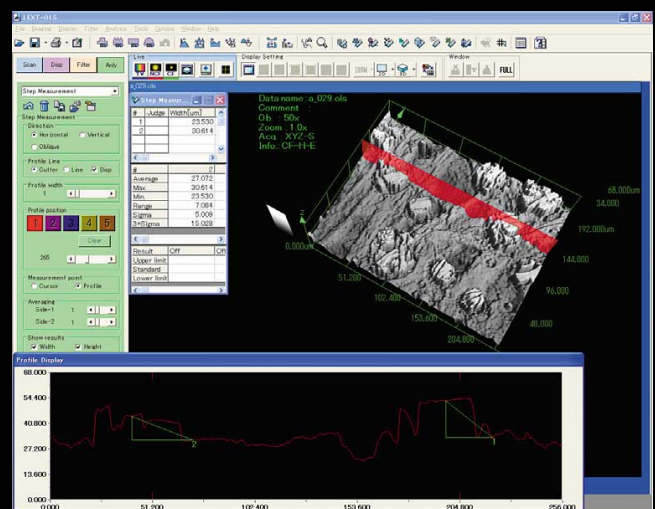

Cross-section measurement

Data: Courtesy of NISSAN ARC, Ltd.

Other LEXT products

Models to respond to individual needs.

Motorized stage/OLS30-CS150AS



Configuration with a motorized stage

● **Stitching (Tiling) function to allow the user to make measurements over a wider area**

LEXT is equipped with the tiling function for integrating a multiple of images into a single image. An observational area up to 12.8 mm x 12.8 mm can be viewed as one image. Measurement can also be made by viewing a tiled image. Furthermore, work efficiency can be increased considerably by specifying the image capturing method as a recipe setting.

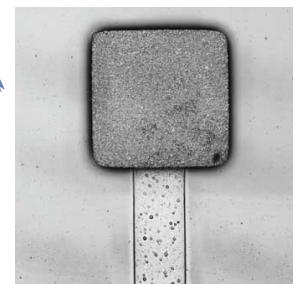
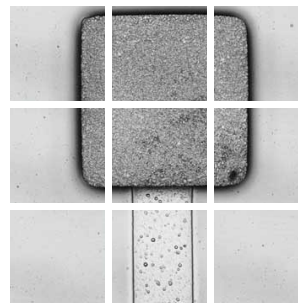

Stitched (Tiled) image

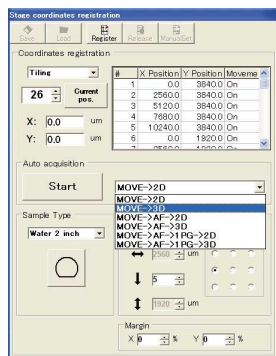

Recipe setting screen

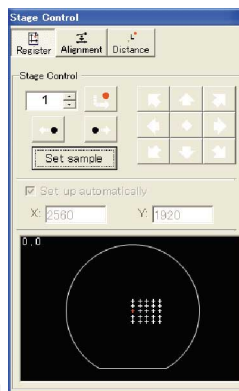

Consecutive setting screen

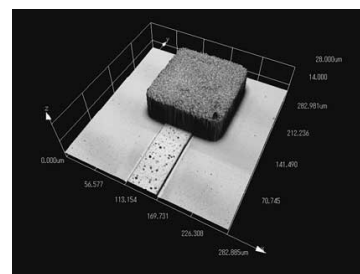

Measured image

● **Consecutive measurement of multiple points**

Registered positions on a specimen can be automatically and consecutively captured under the same conditions. This makes it possible to automate the taking of measurements.

Confocal laser scanning microscope for 300-mm wafer observation/OLS3000-300

This product may not be available in your area. Please consult your Olympus dealer.



Specifications

		Laser scan	Universal
Observation method		Laser	Laser, Laser confocal DIC, Brightfield, DIC
Microscope stand	■ Illumination	408 nm LD laser, Class 2	White LED illumination
	■ Laser	—	
	■ Z stage	Vertical movement/Maximum height of specimen	70 mm/100 mm
	■ Z revolving nosepiece	Stroke/Resolution/Repeatability	10 mm/0.01 μm/3 σ = 0.04+0.002L μm
Objective lens		5x, 10x, 20x, 50x, 100x	
Total magnification		120x–14400x	
Field of view		2560x2560–21x21 μm	
Optical zoom		1x–6x	
Stage *	Manual stage/Motorized stage	100x100 mm/150x100 mm	
Frame memory	Intensity/Height	1024x1024x12 bit/1024x1024x16 bit	
AF		Laser reflection type	
Dimensions		464(W)x559(D)x620(H) mm	
Weight		56.9 kg	57.5 kg

*300 mm x 300 mm stage is optional upon special order basis.

LEXT unit dimensions

(Unit: mm)

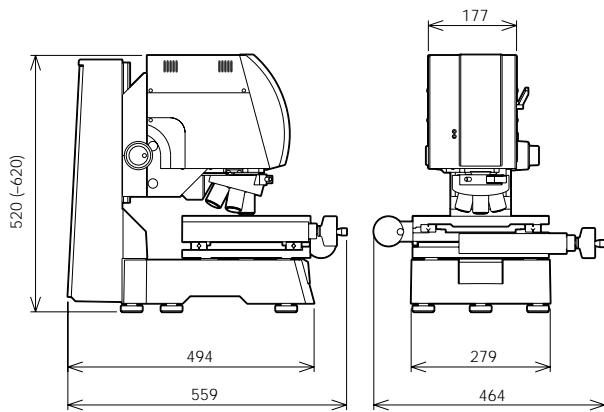

■ Monitor *

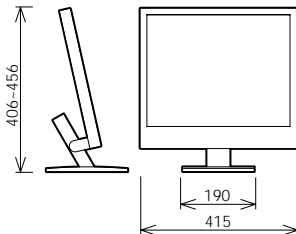

■ PC *

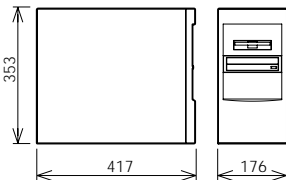

■ Control unit

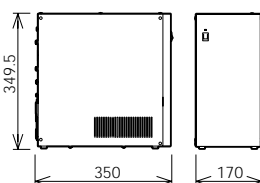

LEXT configuration dimensions

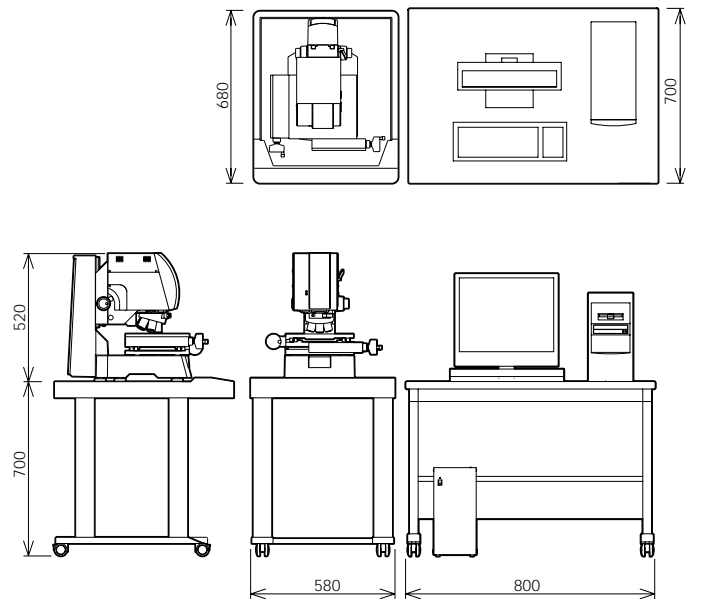

(Unit: mm)

* PC & monitor have slightly different dimensions dependent on the area of region.



●OLYMPUS CORPORATION has obtained ISO9001/ISO14001.

Specifications are subject to change without any obligation on the part of the manufacturer.

OLYMPUS[®]

OLYMPUS CORPORATION
Shinjuku Monclith, 3-1, Nishi Shinjuku 2-chome, Shinjuku-ku, Tokyo, Japan
OLYMPUS LIFE AND MATERIAL SCIENCE EUROPA GMBH
Postfach 10 49 03, 20034, Hamburg, Germany
OLYMPUS SURGICAL & INDUSTRIAL AMERICA INC.
One Corporate Drive, Orangeburg, NY 10962, U.S.A.
OLYMPUS UK LTD.
2-8 Honduras Street, London EC1Y 0TX, United Kingdom.

OLYMPUS AUSTRALIA PTY. LTD.
31 Gilby Road, Mt. Waverley, VIC 3149, Melbourne, Australia.
OLYMPUS LATIN AMERICA, INC.
5301 Blue Lagoon Drive, Suite 290 Miami, FL 33126, U.S.A.

www.olympus.com

Download from www.Somanuals.com. All Manuals Search And Download.

Printed in Japan M1619E-0107B

Free Manuals Download Website

<http://myh66.com>

<http://usermanuals.us>

<http://www.somanuals.com>

<http://www.4manuals.cc>

<http://www.manual-lib.com>

<http://www.404manual.com>

<http://www.luxmanual.com>

<http://aubethermostatmanual.com>

Golf course search by state

<http://golfingnear.com>

Email search by domain

<http://emailbydomain.com>

Auto manuals search

<http://auto.somanuals.com>

TV manuals search

<http://tv.somanuals.com>