

User's Guide

Shop online at

omega.com[®]

Ω OMEGA[®]

www.omega.com

e-mail: info@omega.com

ISO 9001
CERTIFIED
CORPORATE QUALITY

STAMFORD, CT

ISO 9002
CERTIFIED
CORPORATE QUALITY

MANCHESTER, UK

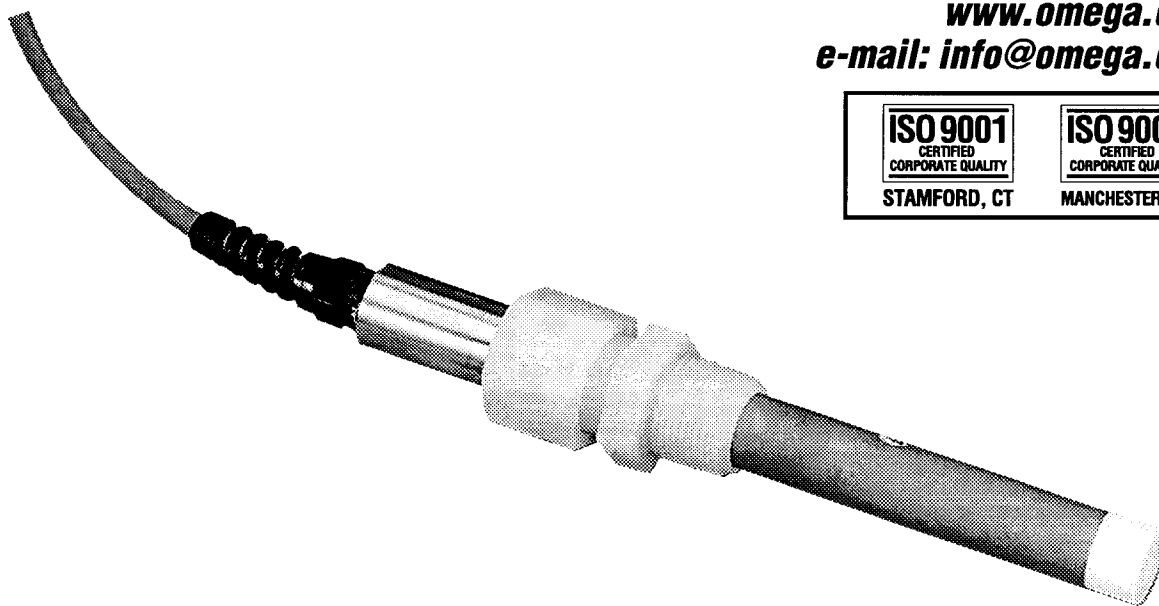

CDE681 SERIES Conductivity/Resistivity Sensors

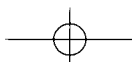



OMEGAnet® Online Service
www.omega.com

Internet e-mail
info@omega.com

Servicing North America:

USA: One Omega Drive, P.O. Box 4047
ISO 9001 Certified Stamford CT 06907-0047
TEL: (203) 359-1660 FAX: (203) 359-7700
e-mail: info@omega.com

Canada: 976 Bergar
Laval (Quebec) H7L 5A1, Canada
TEL: (514) 856-6928 FAX: (514) 856-6886
e-mail: info@omega.ca

For immediate technical or application assistance:

USA and Canada: Sales Service: 1-800-826-6342 / 1-800-TC-OMEGA®
Customer Service: 1-800-622-2378 / 1-800-622-BEST®
Engineering Service: 1-800-872-9436 / 1-800-USA-WHEN®
TELEX: 996404 EASYLINK: 62968934 CABLE: OMEGA

Mexico: En Español: (001) 203-359-7803 e-mail: espanol@omega.com
FAX: (001) 203-359-7807 info@omega.com.mx

Servicing Europe:

Benelux: Postbus 8034, 1180 LA Amstelveen, The Netherlands
TEL: +31 (0)20 3472121 FAX: +31 (0)20 6434643
Toll Free in Benelux: 0800 0993344
e-mail: sales@omegaeng.nl

Czech Republic: Frystatska 184, 733 01 Karviná, Czech Republic
TEL: +420 (0)59 6311899 FAX: +420 (0)59 6311114
Toll Free: 0800-1-66342 e-mail: info@omegashop.cz

France: 11, rue Jacques Cartier, 78280 Guyancourt, France
TEL: +33 (0)1 61 37 29 00 FAX: +33 (0)1 30 57 54 27
Toll Free in France: 0800 466 342
e-mail: sales@omega.fr

Germany/Austria: Daimlerstrasse 26, D-75392 Deckenpfronn, Germany
TEL: +49 (0)7056 9398-0 FAX: +49 (0)7056 9398-29
Toll Free in Germany: 0800 639 7678
e-mail: info@omega.de

United Kingdom: One Omega Drive, River Bend Technology Centre
ISO 9002 Certified Northbank, Irlam, Manchester
M44 5BD United Kingdom
TEL: +44 (0)161 777 6611 FAX: +44 (0)161 777 6622
Toll Free in United Kingdom: 0800-488-488
e-mail: sales@omega.co.uk

It is the policy of OMEGA to comply with all worldwide safety and EMC/EMI regulations that apply. OMEGA is constantly pursuing certification of its products to the European New Approach Directives. OMEGA will add the CE mark to every appropriate device upon certification.

The information contained in this document is believed to be correct, but OMEGA Engineering, Inc. accepts no liability for any errors it contains, and reserves the right to alter specifications without notice.

WARNING: These products are not designed for use in, and should not be used for, human applications.

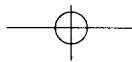

CDE681 Series Conductivity/Resistivity Sensors



HELPFUL IDENTIFIERS

In addition to information on installation and operation, this instruction manual may contain WARNINGS pertaining to user safety, CAUTIONS regarding possible sensor malfunction, and NOTES on important, useful operating guidelines.



WARNING:

A warning looks like this. Its purpose is to warn the user of this sensor of the potential for personal injury.



CAUTION:

A caution looks like this. Its purpose is to alert the user of this sensor to possible sensor malfunction or damage.



NOTE:

A note looks like this. Its purpose is to alert the user of this sensor to important operating information.

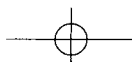

Table of Contents**Part One - Introduction****Section 1 General Information**

1.1 Description:

Benefits of Enhanced Performance Design 1

Compatible Meters 1

1.2 Operating Precautions 1

Section 2 Specifications 2**Part Two - Installation****Section 1 Location Requirements 3****Section 2 Mounting**

2.1 Insertion Mounting 3-5

2.2 Immersion Mounting 6-7

Section 3 Sensor/Interconnect Cable Details

3.1 Sensor Cable Details 8

3.2 Interconnect Cable Details 8-9

3.3 Connecting Interconnect Cable 9

Part Three - Service and Maintenance**Section 1 Recommended Cleaning Procedure 10****Section 2 Troubleshooting**

2.1 Checking Sensor Operation 11

2.2 Customer Assistance 12



CDE681 Series Conductivity/Resistivity Sensors



List of Figures

Figure 2-1 General Dimensions and Cable Wire Details 3

Figure 2-2 Insertion Mounting Details 4

Figure 2-3 Compression Fitting Parts Arrangement
For Insertion Mounting 5

Figure 2-4 Immersion Mounting Details 6

Figure 2-5 Interconnect Cable Termination Details 9

Table

Table A Sensor Operational (Resistance) Checks 11



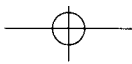

CDE681 Series Conductivity/Resistivity Sensors

NOTES:

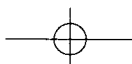

PART ONE - INTRODUCTION

SECTION 1 - GENERAL INFORMATION

1.1 Description

Benefits of Enhanced Performance Design

CDE681-series compression fitting style sensors are manufactured to exacting tolerances using high quality, rugged materials for demanding ultrapure water and pure water applications. Each sensor is:

- Individually tested to determine its absolute cell constant (shown on its label as $K =$), and its temperature element value (to the nearest 1.0 ohm). Entering each sensor's OMEGA-certified "K" value and temperature "T" factor during instrument configuration or calibration, ensures the highest possible measurement accuracy.
- Built with a Pt 1000 RTD temperature element located at its tip to provide exceptionally fast response to changes in temperature with high measuring accuracy ($\pm 0.2^{\circ}\text{C}$).

Compatible Meters

These sensors are for use with the CDCN684, CDCN685, CDCN686 Analyzers and CDTX680 Series transmitters only.

Sensor Characteristics

Basic Cell Constant: 0.05, 0.5, 1.0, 5.0, or 10.

Installation Style: For sensors with a 0.05 cell constant, use ½-inch or ¾-inch male NPT compression fittings made of Kynar (PVDF) or 316 stainless steel. For sensors with any other cell constant, use a ¾-inch male NPT compression fitting made of Kynar or 316 stainless steel. In all cases, the fitting enables the sensor to be insertion mounted, up to 4 inches / 102 mm deep, into a pipe tee or vessel. Reversing the fitting enables the sensor to be fastened onto the end of a pipe for immersion mounting.

Termination Style: An integral 6 m (20 ft.) long cable

1.2 Operating Procedures

Always consider the temperature/pressure ratings of the mounting hardware used to install the sensor. The sensor and hardware combination is an integrated system. The hardware material usually limits the system's temperature/pressure rating. Refer to Section 2 for complete specifications.

SECTION 2 - SPECIFICATIONS

- Wetted Materials Titanium electrodes (316 stainless steel outer electrode for extended sensor body style used with ball valve assembly), PTFE Teflon insulator, and treated Viton O-ring seals
- Maximum When used with Kynar (PVDF) compression fitting:
Temperature 150°C at 1.7 bar (302°F at 25 psi)
When used with 316 stainless steel compression fitting:
150°C at 13.7 bar (302°F at 200 psi)
- Maximum Pressure. When used with Kynar (PVDF) compression fitting:
10.3 bar at 36°C (150 psi at 97°F)
When used with 316 stainless steel compression fitting:
13.7 bar at 150°C (200 psi at 302°F)
- Flow Rate 0-3 m (0-10 ft.) per second (fully immersed)
- Temperature Pt 1000 RTD
Compensator
- Sensor Cable:
Integral 6 wire cable (4 conductors and two isolated shield wires); 6 m (20 ft.) long
(no junction box)

Model No.	Cell Constant	Compression Material	Fitting Thread
CDE681-A-K	0.05	Kynar (PVDF)	½ NPT
CDE681-A-S		316SS	
CDE681-B-K	0.5	Kynar	¾ NPT
CDE681-B-S		316SS	
CDE681-C-K	1.0	Kynar	¾ NPT
CDE681-C-S		316SS	
CDE681-D-K	5.0	Kynar	¾ NPT
CDE681-D-S		316SS	
CDE681-E-K	10.0	Kynar	¾ NPT
CDE681-E-S		316SS	

PART TWO - INSTALLATION

SECTION 1 - LOCATION REQUIREMENTS

Locate the sensor as close as possible to the measuring instrument. Do not exceed a distance of 91 m (300 feet) between the sensor and instrument.

SECTION 2 - Mounting

The CDE681-series compression fitting style sensor may be insertion mounted into a pipe tee or vessel fitting. By reversing the compression fitting, the sensor can be fastened to the end of an appropriate length pipe for immersion mounting. The "longer version" compression style sensor is intended to be mounted into a ball valve assembly, enabling sensor removal without stopping the process flow. Figure 2-1 shows the sensor's general dimensions.

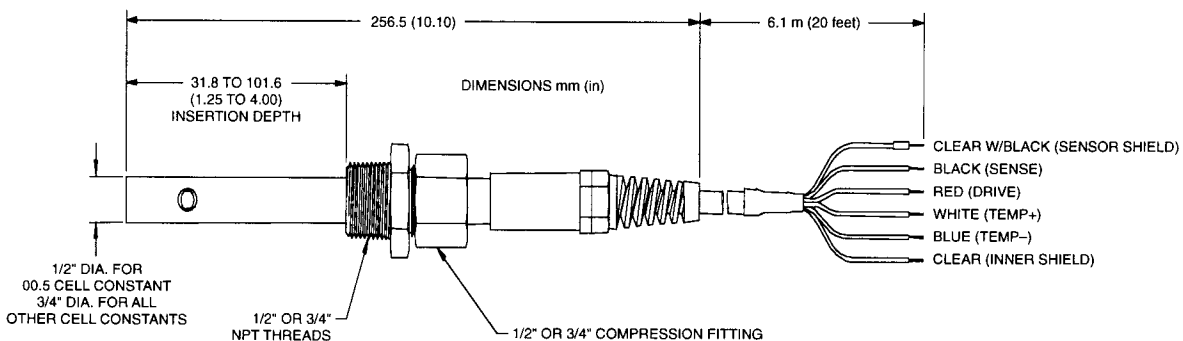
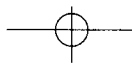

Figure 2-1. General Dimensions and Cable Wire Details

2.1 Insertion Mounting

To ensure optimum measurement performance, follow these guidelines when insertion mounting the sensor:

- Install the sensor into the pipe run so that the process flows directly into the end of the sensor (see Figure 2-2).
- Preferably, mount the sensor in a vertical position to eliminate the possibility of trapped air bubbles from contacting its electrodes which can cause measurement error. This also prevents loose pipe line sediment from accumulating and obstructing the sensor electrodes.



1

CDE681 Part 2 - Installation

1. Install a pipe tee of appropriate size ($\frac{1}{2}$ to 2 inch) and material into the process pipe. If necessary, screw a respectively-sized reducer into the pipe tee.

NOTE:

Use thread sealant on the mounting hardware threads to avoid leaks. **Recommendation:** Use Teflon tape or pipe sealant with Teflon. (Exception: For higher temperature solutions, sealing with Teflon tape may not be adequate.)

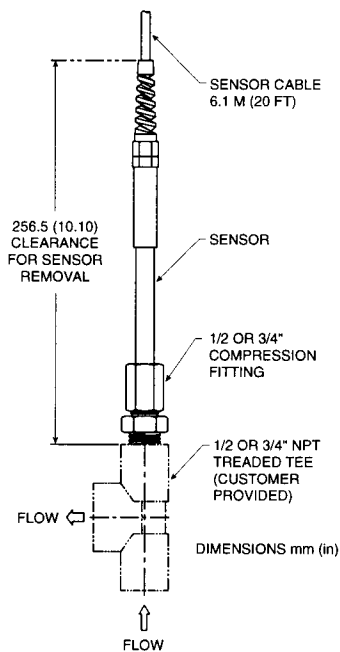
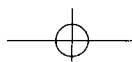

Figure 2-2. Insertion Mounting Details

2. Remove the compression fitting from the sensor and screw it into the pipe tee (or reducer, if used).
3. Electrically connect sensor to analyzer. Refer to analyzer instruction manual for details.
4. Calibrate analyzer using procedure in analyzer instruction manual.
5. After calibration, mount the sensor into the tee:
 - A. Place compression nut and ferrule onto the sensor, compression nut first.

NOTE:

Correctly orient the ferrule onto the sensor as shown in Figure 2-3 to get an effective seal.



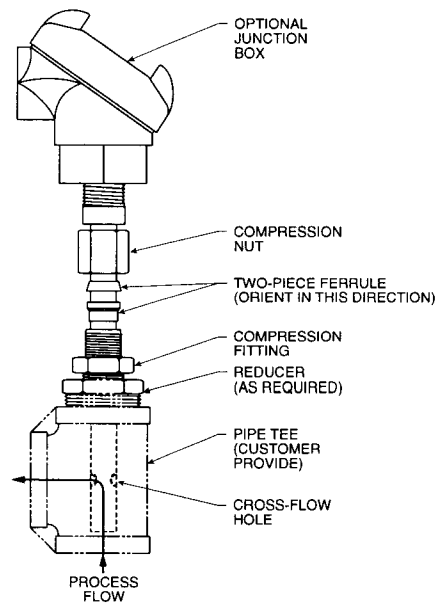

Figure 2-3. Compression Fitting Parts Arrangement For Insertion Mounting

- B. Insert the sensor into the compression fitting. Then adjust the insertion depth to position the sensor's "cross-flow" holes at the center of the tee, and directly in the process flow path.

NOTE:

Rotate the sensor to align one of its "cross-flow" holes with the exiting process flow path as shown in Figure 2-3.

CAUTION:

After tightening the compression nut, the ferrule will be permanently crimped. Therefore, make sure that the sensor is inserted to the proper depth before tightening the compression nut.

- C. With the sensor properly positioned, tighten the compression nut onto the compression fitting to crimp the ferrule. Use one wrench to hold the fitting and another to turn the nut 1 to 1¼ turns. This should provide an effective process seal. Also, the crimped ferrule becomes a convenient reference indicator for insertion depth when re-inserting the sensor after cleaning.

This completes the insertion mounting

Installation Tip!**Re-using Compression Fitting, Nut, and Crimped Ferrule:**

If the sensor is re-installed, the compression fitting and nut can be re-used. The crimped ferrule, however, may need to be cut away from the sensor to remove it, making it unusable. If you can remove the crimped ferrule without destroying it, and if it can still provide an effective process seal, you can probably re-use it at least the number of times listed below:

Recommended Crimped Ferrule Re-use

Ferrule Material	Number of Re-uses
316 stainless steel	1 after initial use
Kynar® (PVDF)	3 after initial use

2.2 Immersion Mounting

1. Reverse the compression fitting assembly on the sensor so that the longer threaded section faces towards the sensor cable end (see Figure 2-4).
2. Position the compression fitting assembly at the far cable end of the sensor body and tighten the compression nut onto the compression fitting. Use one wrench to hold the fitting and another to turn the nut 1 to 1¼ turns to crimp the ferrule. This provides a process seal.

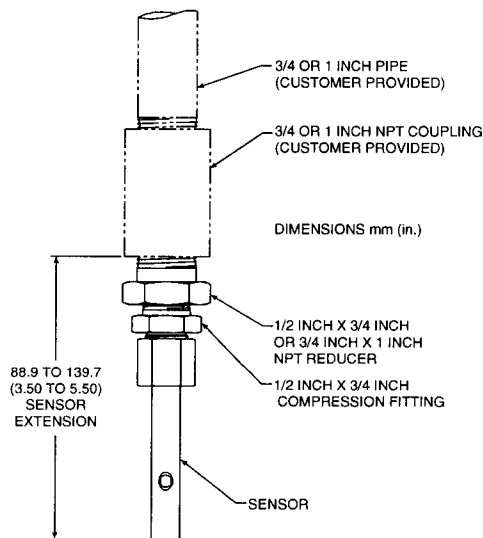

Figure 2-4. Immersion Mounting Details

3. Route the sensor cable through a pipe of an appropriate material and length. Screw the compression fitting onto the end of the pipe (or coupling, if used).

NOTE:

Use thread seal-ant on the pipe threads to avoid leaks.

Recommendation: Use Teflon tape or pipe sealant with Teflon. (Exception: For higher temperature solutions, sealing with Teflon tape may not be adequate.)

4. Fasten a Unilet junction box onto the other end of the pipe.
5. Run interconnect cable from the analyzer into the Unilet junction box. Connect the sensor and interconnect cable wires, by matching colors, to the terminals in the junction box. Fasten the cover onto the junction box.
6. Electrically connect the sensor interconnect cable wires to the analyzer. Refer to the analyzer instruction manual for details.
7. Calibrate the analyzer using the procedure in the analyzer instruction manual.
8. After calibration, mount the sensor into the process.

This completes the immersion mounting.

SECTION 3 - SENSOR/INTERCONNECT CABLE DETAILS

3.1 Sensor Cable Details

The sensor's integral cable is a 6-wire crosslinked polyethylene-jacketed cable with 4 conductors and two isolated shield wires. Refer to Figure 2-1 for the function and color of each wire in the sensor's integral cable.

3.2 Interconnect Cable Details

The OMEGA interconnect cable CDE3600-CAB is provided with unfinished ends since it must often be shortened during installation. The cable is very similar to the sensor's integral cable except that it has two additional conductors (green and yellow) which are not required. When stripping the interconnect cable during termination, purposely cut off these green and yellow wires from each end of the stripped-back cable. This ensures the same wire color coding used by the sensor's integral cable.

NOTE

OMEGA strongly recommends using only its CDE3600-CAB interconnect cable. If a different cable is used, it must have equivalent construction: four conductors, and two separate isolated shields - one shielding the signal, and one shielding the overall cable. These specific cable characteristics protect the measurement signal from electromagnetic interference. Using a cable with different construction may interfere with the measurement system's ability to properly measure.

To correctly terminate the ends of the interconnect cable, refer to Figure 2-6 and follow this procedure:

1. **Carefully** strip back $2\frac{1}{4}$ inches of the outer cable jacket, the outer shield foil, and the cellophane binder. This exposes the sensor shield wire, the inner shield wire, and the three foil-wrapped wire pairs.
2. Cut off the exposed $2\frac{1}{4}$ inches of only the yellow and green wire pair.
3. Peel back and cut off the exposed inner shield foil from the red/black and blue/white wire pairs.
4. **Carefully** strip back an additional $\frac{1}{2}$ inch of the outer cable jacket and outer shield foil.

NOTE

Be careful not to damage the exposed section of the cellophane binder.

5. Carefully position a 2½ inch long piece of shrink tubing or tape on the bare sensor shield wire ¼-inch from the end as shown in Figure 2-6 to insulate and distinguish it from the inner shield wire. Doing this exposes ¼-inch of bare shield wire beyond the tubing or tape for connection purposes.
6. Carefully position a 1-inch long piece of shrink tubing or tape on the cable as shown in Figure 2-6 to secure all wires.

NOTE:

Do not fold back the cellophane binder exposed in step 4.

7. Using an ohmmeter or test light, verify that the sensor shield wire you insulated is not shorted to the bare inner shield wire. If the wires are shorted, cut the cable to get a new unfinished end and start over at step 1.
8. Strip ¼ inch of insulation from the ends of the red, black, white, and blue wires. Tin these leads, the insulated sensor shield wire, and the bare inner shield wire with solder.
9. Connect the interconnect cable to the analyzer in the same way as the sensor cable, by matching colors as indicated.

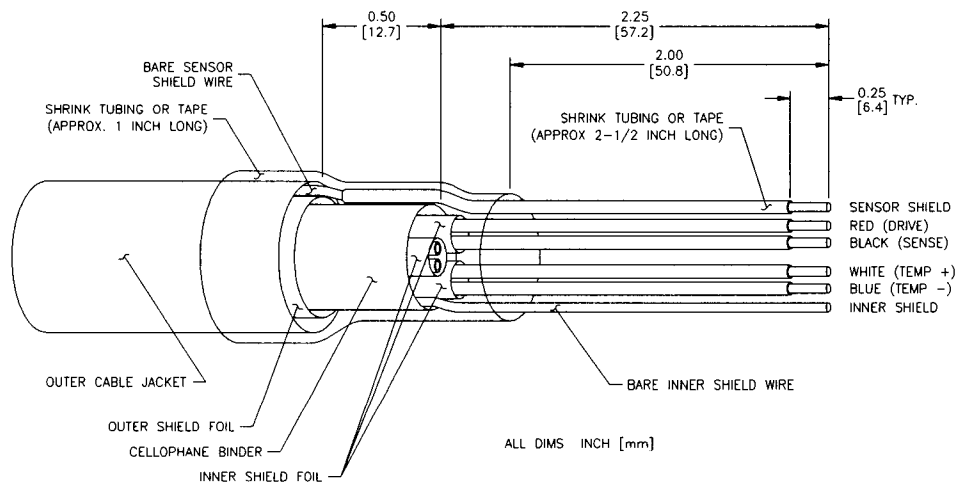

Figure 2-5. Interconnect Cable Termination Details

3.3 Connecting Interconnect Cable

To Analyzer: Refer to the instrument instruction manual and connect the interconnect cable wires to appropriate SENSOR terminals in the same way as the sensor wires would be directly connected.

PART THREE - SERVICE AND MAINTENANCE

SECTION 1 - RECOMMENDED CLEANING PROCEDURE

Keep the sensor reasonably clean to maintain measurement accuracy. The time between cleanings (days, weeks, etc.) is affected by the characteristics of the process solution and can only be determined by operating experience.

1. Remove most contaminate buildup by carefully wiping the inner electrode rod, and the concentric outer electrode tube (inner and outer surfaces) with a soft clean cloth. Then rinse the sensor with clean, warm water.
2. Prepare a mild soap solution. Use warm water and dishwashing detergent, Borax hand soap, or a similar soap.
3. Soak the sensor for 2 to 3 minutes in the soap solution.
4. Use a small bristle brush, cotton swab (Q-tip), or pipe cleaner to scrub the entire measuring end of the sensor, thoroughly cleaning the electrode surfaces. If detergent solution cleaning cannot remove surface deposits, use muriatic acid (or another dilute acid) to dissolve the deposits. The acid should be as dilute as possible, but yet strong enough to clean. Experience will help determine which acid to use and how dilute it can be. Some stubborn coatings may require a different cleaning agent. For assistance in these difficult cases, contact the OMEGA Service Department (see page 12).

Before cleaning with acid, determine if any hazardous reaction products could form. (Example: A sensor used in a cyanide bath should not be put directly into a strong acid for cleaning because poisonous cyanide gas could be produced.) Acids are hazardous. Wear appropriate eye protection and clothing in accordance with Material Safety Data Sheet recommendations.

Soak the sensor in dilute acid for **no more than 5 minutes**. Rinse the sensor with clean, warm water and then place the sensor back into the mild soap solution for 2 to 3 minutes to neutralize any remaining acid.

5. Rinse the sensor in clean, warm water.
6. Calibrate the analyzer using the procedure in the analyzer instruction manual. If calibration cannot be attained, check the sensor using the procedure in Part Three, Section 2.1.

2.1 Checking Sensor Operation

Use the troubleshooting section in the analyzer instruction manual to determine whether the sensor or analyzer is in-operative. If you suspect the sensor, check it using this procedure:

1. Disconnect the sensor from the analyzer (or junction box, if using interconnect cable).
2. Clean the sensor using the procedure in Part Three, Section 1.
3. Using an ohmmeter, check all of the measurement point resistance readings shown in Table A below.

NOTE:

Be sure that the ohmmeter is set to its highest range for all infinite (open circuit) resistance readings shown in Table A.

Table A - SENSOR OPERATIONAL (RESISTANCE) CHECKS

Measurement Points	Correct Resistance Readings
Between blue and white wires	1089-1106 ohms at 23-27°C
Between red wire and sensor body	Less than 5 ohms
Between black wire and inner electrode	Less than 5 ohms
Between black and red wires	Infinite (open circuit)
Between black and white wires	Infinite (open circuit)
Between red and white wires	Infinite (open circuit)
Between red and inner shield wires	Infinite (open circuit)
Between black and inner shield wires	Infinite (open circuit)
Between white and inner shield wires	Infinite (open circuit)
Between outer and inner shield wires	Infinite (open circuit)

4. If you cannot get the required readings for one or more of the resistance checks in step 3, the sensor is probably inoperative. Refer to OMEGA's warranty/replacement plan for sensor replacement details. If all resistance checks are okay, the sensor may still be inoperative. In this case, more extensive troubleshooting is required. Please consult the OMEGA Customer Service Department for details (see page 12).

2.2 Customer Assistance

If you need assistance in troubleshooting or repair service, please contact your local OMEGA representative, or the OMEGA Customer Service Department at:

1-800-633-2378 or 1-203-359-1660.

We can also be reached on the Internet at **www.omega.com**

email: info at omega.com

All sensors returned for repair or replacement must be freight prepaid and include the following information:

1. A clearly written description of the malfunction.
2. Name of person to contact and the phone number where they can be reached.
3. Proper return address for shipping sensor(s) back. Include preferred shipping method (UPS, Federal Express, etc.) if applicable.
4. A purchase order if sensor(s) is out of warranty to cover costs of repair.

NOTE:

If the sensor is damaged during return shipment as a result of inadequate packaging, the customer assumes responsibility for repair costs. It is recommended to use the original OMEGA shipping carton or an equivalent. Also, OMEGA will not accept sensors returned for repair or replacement unless they are thoroughly cleaned and all process chemicals are removed.



WARRANTY/DISCLAIMER

OMEGA ENGINEERING, INC. warrants this unit to be free of defects in materials and workmanship for a period of **13 months** from date of purchase. OMEGA's WARRANTY adds an additional one (1) month grace period to the normal **one (1) year product warranty** to cover handling and shipping time. This ensures that OMEGA's customers receive maximum coverage on each product.

If the unit malfunctions, it must be returned to the factory for evaluation. OMEGA's Customer Service Department will issue an Authorized Return (AR) number immediately upon phone or written request. Upon examination by OMEGA, if the unit is found to be defective, it will be repaired or replaced at no charge. OMEGA's WARRANTY does not apply to defects resulting from any action of the purchaser, including but not limited to mishandling, improper interfacing, operation outside of design limits, improper repair, or unauthorized modification. This WARRANTY is VOID if the unit shows evidence of having been tampered with or shows evidence of having been damaged as a result of excessive corrosion; or current, heat, moisture or vibration; improper specification; misapplication; misuse or other operating conditions outside of OMEGA's control. Components which wear are not warranted, including but not limited to contact points, fuses, and triacs.

OMEGA is pleased to offer suggestions on the use of its various products. However, OMEGA neither assumes responsibility for any omissions or errors nor assumes liability for any damages that result from the use of its products in accordance with information provided by OMEGA, either verbal or written. OMEGA warrants only that the parts manufactured by it will be as specified and free of defects. OMEGA MAKES NO OTHER WARRANTIES OR REPRESENTATIONS OF ANY KIND WHATSOEVER, EXPRESS OR IMPLIED, EXCEPT THAT OF TITLE, AND ALL IMPLIED WARRANTIES INCLUDING ANY WARRANTY OF MERCHANTABILITY AND FITNESS FOR A PARTICULAR PURPOSE ARE HEREBY DISCLAIMED. LIMITATION OF LIABILITY: The remedies of purchaser set forth herein are exclusive, and the total liability of OMEGA with respect to this order, whether based on contract, warranty, negligence, indemnification, strict liability or otherwise, shall not exceed the purchase price of the component upon which liability is based. In no event shall OMEGA be liable for consequential, incidental or special damages.

CONDITIONS: Equipment sold by OMEGA is not intended to be used, nor shall it be used: (1) as a "Basic Component" under 10 CFR 21 (NRC), used in or with any nuclear installation or activity; or (2) in medical applications or used on humans. Should any Product(s) be used in or with any nuclear installation or activity, medical application, used on humans, or misused in any way, OMEGA assumes no responsibility as set forth in our basic WARRANTY/DISCLAIMER language, and, additionally, purchaser will indemnify OMEGA and hold OMEGA harmless from any liability or damage whatsoever arising out of the use of the Product(s) in such a manner.

RETURN REQUESTS/INQUIRIES

Direct all warranty and repair requests/inquiries to the OMEGA Customer Service Department. BEFORE RETURNING ANY PRODUCT(S) TO OMEGA, PURCHASER MUST OBTAIN AN AUTHORIZED RETURN (AR) NUMBER FROM OMEGA'S CUSTOMER SERVICE DEPARTMENT (IN ORDER TO AVOID PROCESSING DELAYS). The assigned AR number should then be marked on the outside of the return package and on any correspondence.

The purchaser is responsible for shipping charges, freight, insurance and proper packaging to prevent breakage in transit.

FOR **WARRANTY** RETURNS, please have the following information available BEFORE contacting OMEGA:

1. Purchase Order number under which the product was PURCHASED,
2. Model and serial number of the product under warranty, and
3. Repair instructions and/or specific problems relative to the product.

FOR **NON-WARRANTY** REPAIRS, consult OMEGA for current repair charges. Have the following information available BEFORE contacting OMEGA:

1. Purchase Order number to cover the COST of the repair,
2. Model and serial number of the product, and
3. Repair instructions and/or specific problems relative to the product.

OMEGA's policy is to make running changes, not model changes, whenever an improvement is possible. This affords our customers the latest in technology and engineering.

OMEGA is a registered trademark of OMEGA ENGINEERING, INC.

© Copyright 2003 OMEGA ENGINEERING, INC. All rights reserved. This document may not be copied, photocopied, reproduced, translated, or reduced to any electronic medium or machine-readable form, in whole or in part, without the prior written consent of OMEGA ENGINEERING, INC.



Where Do I Find Everything I Need for Process Measurement and Control? **OMEGA...Of Course!** *Shop online at www.omega.com*

TEMPERATURE

- Thermocouple, RTD & Thermistor Probes, Connectors, Panels & Assemblies
- Wire: Thermocouple, RTD & Thermistor
- Calibrators & Ice Point References
- Recorders, Controllers & Process Monitors
- Infrared Pyrometers

PRESSURE, STRAIN AND FORCE

- Transducers & Strain Gages
- Load Cells & Pressure Gages
- Displacement Transducers
- Instrumentation & Accessories

FLOW/LEVEL

- Rotameters, Gas Mass Flowmeters & Flow Computers
- Air Velocity Indicators
- Turbine/Paddlewheel Systems
- Totalizers & Batch Controllers

pH/CONDUCTIVITY

- pH Electrodes, Testers & Accessories
- Benchtop/Laboratory Meters
- Controllers, Calibrators, Simulators & Pumps
- Industrial pH & Conductivity Equipment

DATA ACQUISITION

- Data Acquisition & Engineering Software
- Communications-Based Acquisition Systems
- Plug-in Cards for Apple, IBM & Compatibles
- Datalogging Systems
- Recorders, Printers & Plotters

HEATERS

- Heating Cable
- Cartridge & Strip Heaters
- Immersion & Band Heaters
- Flexible Heaters
- Laboratory Heaters

ENVIRONMENTAL MONITORING AND CONTROL

- Metering & Control Instrumentation
- Refractometers
- Pumps & Tubing
- Air, Soil & Water Monitors
- Industrial Water & Wastewater Treatment
- pH, Conductivity & Dissolved Oxygen Instruments

M3594/0603

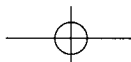

Free Manuals Download Website

<http://myh66.com>

<http://usermanuals.us>

<http://www.somanuals.com>

<http://www.4manuals.cc>

<http://www.manual-lib.com>

<http://www.404manual.com>

<http://www.luxmanual.com>

<http://aubethermostatmanual.com>

Golf course search by state

<http://golfingnear.com>

Email search by domain

<http://emailbydomain.com>

Auto manuals search

<http://auto.somanuals.com>

TV manuals search

<http://tv.somanuals.com>