

6.1-Check that the final rotational position for the ball shaft is correct. Place the appropriate size wrench on the shoulder nut. With equal pressure push against the ball shaft in the opposite direction as you tighten the nut. This will minimize the stress on both the mounting plate and the ceiling.

NOTE: If you try to move the ball shaft without first loosening it where it joins the mounting plate, lateral forces will transmit to the mounting plate fasteners. The resulting stress, transferred to the mounting surface, could weaken the installation.

6.2-If you need to readjust the lateral position of the ball shaft, **always** loosen the shoulder nut first.

Remember: tighter does not mean better! Over-tightening fasteners can weaken the installation and damage your speaker.

Whenever you need to readjust the position of the speaker to move freely around the ball, re-adjust to the **new** position and **then** re-tighten. Always remember to support the speaker when repositioning and when tightening the clamp assembly.

6.3-IMPORTANT Since the ball will slowly compress under pressure, you should check the clamp after 15 minutes and tighten again if necessary. Then check once more in approximately one hour. Always support the weight of the speaker while positioning it and tightening the clamp.

Congratulations! Your installation is now complete!

Additional Reference...

1. U.B.C. (Uniform Building Code) 1994 Edition, Vol. 2, "Structural and Engineering Design Provisions."
2. United States Department of Agriculture, Agriculture Handbook #72, "Wood as an Engineering Material," Prepared by: Forest Products Laboratory, Forest Service, USDA
3. NDS Commentary on the National Design Specification® for Wood Construction (Commentary on the 1991 Edition), American Forest and Paper Association.

OmniMount products have been installed successfully worldwide for many years. To help ensure the safe and proper use of our products, we believe it is our responsibility to provide clear, detailed instructions with periodically updated precautionary information. Please Note: Every effort has been made to provide accurate and error-free assembly and installation information. OmniMount® Systems, Inc. disclaims liability for any difficulties arising from the interpretation of information contained in these instructions. OmniMount

Systems, Inc. cannot reasonably assume responsibility or liability — direct, indirect or consequential — for the structural integrity or suitability of any speakers; nor the suitability for mounting or the structural integrity of the surfaces (walls, ceilings, decks, floors, etc.) to which such speakers are to be mounted. The same holds true for design or manufacturing defects in speakers themselves or design changes made by speaker manufacturers that may affect the safe and secure mounting of their speakers.

The General Ceiling Mounting Information and Installation Instructions provided herein are for use in the installation of loudspeakers. Although OmniMount products are often used to support many different kinds of objects, installed on a variety of mounting surfaces, such use and installation may be subject to different specifications requiring installation information in addition to what is provided in this pamphlet. In such cases, be sure to ascertain suitability and obtain the required additional installation information.

Notice to the Purchaser:
The following is made in lieu of all warranties expressed or implied: the Manufacturer's only obligation shall be to replace parts of this product proved to be defective within two years of the date of purchase. We are aware that this mounting assembly may be used for purposes and in ways other than those for which it has been designed and manufactured. The Manufacturer, Distributor, Retailer, and their respective Agents cannot be held responsible or liable for injuries or property damage—direct, indirect or consequential—arising out of the use or inability to use this product safely and properly.

Model 30.0 CA

Mounts from ceiling to back of speaker.



General Ceiling Mounting Information and Installation Instructions



Precautions-Read this section carefully

Whenever a speaker is affixed to a ceiling, you must take special care to mount it securely to prevent it from falling and causing damage or injury. For a safe and secure installation use good judgement and common sense throughout all phases of the installation.

Load

The OmniMount 30.0 CA will support speakers weighing up to 30 pounds (13.6 Kg). Be aware of basic physical laws that affect balance, stability and weight distribution. If your speaker is heavier than 30 pounds, we manufacture larger mounts with greater maximum weight ratings.

Mounting Surfaces

Carefully evaluate the composition, construction and strength of the surface you are mounting to. OmniMount 30.0 Series products are packaged with fasteners intended for use in mounting to interior ceilings of standard joist or beam construction. The installation instructions provided here are limited to this type of ceiling construction.

OmniMount 30.0 Series products can be mounted to steel beams, concrete slabs and other types of ceiling construction. This type of construction does, however, require special anchors and fasteners for a secure and safe installation. There are standard construction practices and fastening products available for mounting to these types of structural surfaces. Seek professional help or contact OmniMount Systems technical support for more information.

The safety and security of your installation is most critically dependent on how securely the OmniMount 30.0 mounting plate is affixed to the ceiling.

When mounting things to ceilings here are some of the most common installation errors: Not locating the precise center of the joist—screwing fasteners into an edge rather than the center of the joist. This results in either splitting the wood or only partially engaging the screw shaft. (See Figs. 1 & 2)



To maximize pull-out strength, the screw shaft needs to be located in the center of the joist. (See Fig. 3)

Screw Related Installation Errors.

Drilling a pilot hole is necessary to prevent the wood from splitting. The pilot hole is also required to provide a straight pathway for the screw to travel as it penetrates the stud. A pilot hole should serve to simply **guide** the travel of the screw. (See Figs. 4 & 5)

Drilling "pilot" holes that are too large for the diameter of the screw shaft significantly reduces "pull-out" strength.

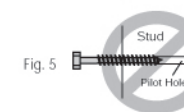
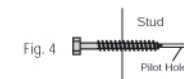

Screws have a major diameter and a minor diameter. (See Figs. 6 & 7) The pilot hole should always be smaller than the minor diameter of the screw shaft.



Always use screws long enough to penetrate deeply into the joist or beam. (See Figs. 8 & 9)

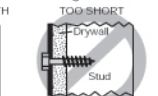
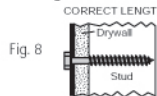

Locating the Center of a Joist

Do not rely on a measuring tape alone. Standard joist construction practice places joists on centers between 12" and 24". But in reality, joists are not always consistently on these centers. You find the greatest discrepancy in joist centers when you measure from the corner of a room, starting with the first joist. It may be helpful to locate several joists on the ceiling and measure their approximate centers.

There are a variety of electronic and magnetic stud or joist finders available on the market. They can be a useful tool for finding the joist. But it is essential that you locate the exact center of the joist. How to do this is detailed in these installation instructions.

About The Speaker You Are Mounting To...

Some manufacturers provide "OmniMount prepped" threaded inserts on the back of their speakers. Such speakers have inserts that line up precisely with the hole centers in the OmniMount clamp plate.

Be sure to provide adequate reinforcement to the speaker if it is determined that such reinforcement is necessary.

When no threaded inserts for mounting purposes have been provided by the speaker manufacturer, a

speaker can still be safely mounted on the wall. But you have to be sure that it is put together strongly enough with materials strong enough to support its own weight with the #14 coarse thread screws and anchors provided. Most compact speakers are made well enough and use adequate materials with adequate thickness for mounting with an OmniMount assembly. The #14 screws should not be used in masonite®, thin panel wood, or plastic. Such materials will likely require different fastening hardware and methods. The speaker may also need reinforcement to be mounted safely. If your evaluation raises any questions about the speaker's construction or material strength, contact your dealer or the speaker manufacturer and **ASK QUESTIONS!** More on this later...

More Precautions-Read this section carefully.

Fasteners

Attaching the clamp assembly and the mounting plate/ball shaft requires fasteners appropriately selected for strength and composition of the mounting surfaces involved. The type of fasteners and anchors OmniMount Systems has provided have been carefully selected. They are suitable for the majority of installation situations as discussed in these instructions. Occasionally, there will be an installation situation for which the fasteners provided are not suitable. If it is determined that different fasteners are required, they must always be 5/16 in. diameter for the mounting plate, 1/4 in. diameter for the clamp assembly. Fasteners must always be used in **all** available mounting holes. Never use smaller diameter fasteners (if you drill pilot holes, the holes should be **smaller** than the core diameter of the screws). Do not over-tighten fasteners. Over-tightening can weaken the mounting surface, damage the fasteners, and make the attachment **less** secure.



If you are not sure about the suitability of the fasteners provided for your installation, **ASK QUESTIONS!**

NOTE: A second person is necessary to hold the speaker in place during the tightening procedure.

Securing the clamp assembly to the speaker.

There are four things you need to know about your speaker before you begin:

- 1- Are any internal components (such as the crossover network) directly behind the location onto which you will be mounting the clamp assembly?
- 2- Is the material you are mounting into strong enough to safely support the load?
- 3- Is internal reinforcement needed?
- 4- Are the fasteners provided suitable for your installation?

NOTE: When mounting the clamp assembly, you will need a minimum of 1/4" clearance inside the speaker enclosure away from any internal components. The easiest way to find out if you have adequate clearance, is to check directly with the speaker manufacturer. Or, you can check yourself by carefully removing the largest driver (speaker component). Move any insulation out of the way and physically check the clearance. If you check by removing the driver, be careful not to over-tighten the screws when you replace it. If you had planned to mount the clamp assembly to the back of the speaker and discover later that components are mounted on the inside rear, or too close to the back of the speaker, you will have to use a different OmniMount model. 30.0 WB and 30.0STMP models, for example, are ideal for mounting to the top or bottom of the speaker. Usually, good quality speakers are made of good



OmniMount Systems, Inc
The Pointe at South Mountain
8201 South 48th Street
Phoenix, Arizona 85044-5355
Voice: (480) 829-8000
Fax: (480) 30.06-9000
1-800-MOUNT-IT (668-6848)
email: hdqrs@omnimount.com
Web: www.omnimount.com

manufacturers use 1/2" to 3/4" thick Medium Density Fiberboard (MDF), more commonly known as particle board or press board. Some high-end speakers are constructed of voidless Birch plywood. If you are unsure A) about the suitability of the fasteners provided or, B) about the speaker's integrity of materials and construction in relation to how you plan to mount it—**Ask Questions!!!** The speaker must be able to support its own weight safely over an extended period of time.

The alternative would be to use OmniMount Model 30.0 STMP-IFK suspending the speaker from its top. Verify with the speaker manufacturer that the speaker is adequately constructed to suspend its own weight, over time, in this manner.

About drilling holes in your speaker...

Question: Will I compromise the sonic (acoustic) integrity of my speaker?

Answer: Not really at all, as long as you fill the hole with a fastener.

Factory installed inserts are often "sealed" with a machine screw which can later be used to attach the clamp assembly. Sometimes, threaded inserts that are closed-off or "blind" at the bottom are factory installed in speakers.

Question: If my speakers do not have inserts, will I void the speaker warranty if I drill holes into my speaker enclosure?

Answer: We have not found this to be the case (check if you want to). Speaker manufacturers want their speakers to sound their best and generally endorse the use of OmniMount products because of the flexible placement and positioning OmniMount offers serves to improve the sound. Of course, if you "drill for oil" and hit some internal components on the way, well, that's another story. But we do address how to avoid drilling holes too deep later in our installation instructions.

Question: What happens if I want to sell my speakers in the future?

Answer: Industry research shows that almost no one ever does. But, should you want to sell them in the future, OmniMount will likely **add** value to the sale.

OMNIMOUNT 30.0 CA—INSTALLATION INSTRUCTIONS

DESCRIPTION

The OmniMount 30.0 CA model is used for securing your speaker to the ceiling. The mounting angle can be adjusted by loosening the clamp assembly tension screw and locked into position by simply tightening it.

Each mount is rated for speakers weighing up to 30 pounds (13.6 Kg) and should be installed only on a horizontal surface. Surfaces must be strong, flat and stable. There are two basic components to this OmniMount system:

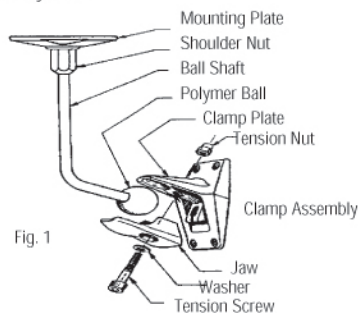

Fig. 1

- The mounting plate/ball shaft mounts to the ceiling.
- The clamp assembly—consisting of the clamp plate and jaw—mounts to the back of the speaker. The clamp assembly provides the clamping action that surrounds and compresses on the ball, locking in the chosen angle of adjustment. (See Fig. 1)

PREVIEWING THE PROCEDURE

The installation sequence consists of the following steps in this order:

- 1) Mounting the clamp assembly to the back of the speaker.
- 2) Attaching the mounting plate to the mounting surface.
- 3) Joining the clamp assembly to the mounting plate/ball shaft.
- 4) Adjusting the position of the speaker and tightening the clamp assembly.

Before you begin, familiarize yourself with the installation procedures by reading through the precautions and installation instructions from beginning to end.

TOOLS REQUIRED

- 1/4" allen hex wrench (supplied)
- 5/32" pilot hole drill bit
- Joist Locating Probes (supplied)
- Small hammer
- Drill motor, 3/16" and 5/16" drill bit
- Medium size crescent wrench
- 3/4" open-end wrench
- A medium to large phillips screwdriver
- A power driver with phillips head bit (optional)
- Masking tape
- A carpenter's bubble type level

Fasteners etc. (Included)

- 4—Togglers*
- 4—#14 phillips screws
- 4—1/4"—20 phillips machine screws
- 3—3" lag bolts
- 2—Joist Locating Probes

ATTACHING THE CLAMP ASSEMBLY TO THE SPEAKER



Have you read and understood all of the "PLEASE READ THIS FIRST" information in the preceding pages? If so, let's begin...

INSTALLATION

1.1-Place the speaker on a flat protected surface. Take care not to damage the drivers or speaker grille. If necessary, protect any protruding components on the front by blocking the speaker with cloth-wrapped 2 x 4's to raise the area where the damage could occur.

1.2-Place the template as indicated in Fig. 2 over the chosen location. Be sure the template is centered

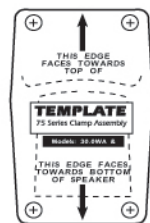

Fig. 2

and straight. Tape it down with masking tape. Locate

the Joist Locating Probes. Use one and tap a mark in the center of each of the four corners of the template—carefully in the middle of each "crosshair." Remove the template (See Fig 2).



Fig. 2

1.3-Insert a 3/16" diameter drill bit into your drill motor. Measure 3/4" from the end of the drill bit and wrap a piece of tape around the drill bit shaft, allowing 3/4" to protrude. Carefully center the drill on each starter hole location and drill four holes slowly penetrating only to the bottom edge of the tape (3/4"). Remove the 3/16" drill bit and replace it with a 5/16" diameter drill bit. Measure 3/4" from the end of the drill bit and wrap a piece of tape around the shaft, allowing 3/4" to protrude. Carefully center the drill over the four existing holes and slowly drill down 3/4 of an inch to the bottom edge of the masking tape.

1.4-You now need to separate the clamp assembly from the mounting plate/ball shaft components. Using the 1/4" allen hex wrench, loosen the tension screw in the clamp assembly until the jaw opens—**ONLY** enough so that you can release the ball. **Do not** unscrew the tension screw completely.

1.5-Place the clamp assembly over the holes to verify that the four holes are centered.

1.6-Remove the clamp assembly and hand insert four togglers into each hole. Using a hammer, tap gently until the bottom of the toggler flange is flush with the surface of the speaker (Fig. 3).

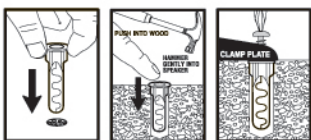

Fig. 3

Position the clamp assembly, as indicated in figure 3A. Insert the four screws through the clamp assembly and into each toggler.

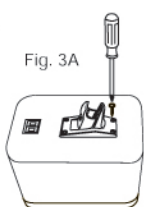

Fig. 3A

Tighten firmly, but do not tighten excessively—**Do not over-tighten.** Tighter than "firm" does not add pull-out strength and over-tightening could weaken the installation.

ATTACHING THE MOUNTING PLATE TO THE MOUNTING SURFACE

The mounting plate has four holes. Two of the four holes must be aligned with the edge of a ceiling joist. Attaching two lag bolts through two of the holes in the mounting plate and into the bottom edge of the joist is essential for a safe and secure installation.

Proceed as follows:

2.1-Locate the joist onto which you will be mounting. Position the bracket on the joist at the approximate location where you want the mounting plate so that the long dimension is

perpendicular to the wall (See Fig. 4). Find the center of the mounting plate and position it over what you believe to be the horizontal center of the joist. Lightly pencil mark two lines on each side of the mounting plate about 2" long. Remove the mounting plate and draw a horizontal line across the center, connecting the two vertical pencil lines. (See Fig. 4)

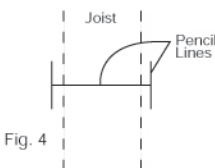

Fig. 4

2.2-Locate the two Joist Locating Probes. You will use these to find the center of the joist. Moving along the horizontal line, use a hammer with the probe, to tap holes through the ceiling. Alternating at each side, tap holes along the horizontal pencil line with spacing that is no more than 1/16" increments, until you have located the outside edge of the joist on both sides. (See Fig. 5)

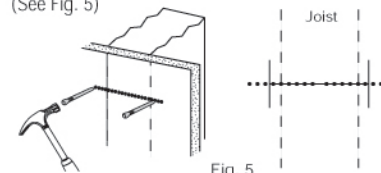

Fig. 5

2.3-Once you have found the outside edges of the joist, insert the two probes into the holes closest to the edges of each side of the joist. (See Fig 6) Measure the distance between them. It should be approximately 1 1/2" between the two edge-locating holes. Split the difference—Measure 3/4" in from each end and mark the location. This location should be the center with a straight line perpendicular to the wall. (See Fig. 6)

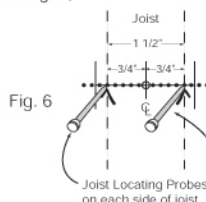

Fig. 6

NOTE: Check that the surface preparation and the fasteners will not interfere with electrical wiring, plumbing, duct work, etc., inside the ceiling.

2.4-Place the mounting plate on the ceiling location you have chosen. The pencil line you have made should be visible as you look through the two joist attaching holes in the mounting plate. (See Fig. 7)

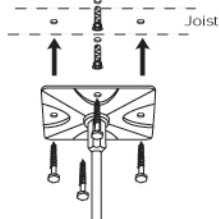

Fig. 7

2.5-Remove the mounting plate and prepare the mounting surface and all holes. You can use one of the probes to make a starter hole for the drill bit. Having located the exact center of the joist, insert the 5/32" pilot hole drill bit into your drill motor. Drill four pilot holes; two into the joist, two into the mounting surface. If the mounting surface is gypsum board you will use two togglers in the holes on either side of the joist location holes. (See Fig. 7.) Be sure to use all four supplied lag bolts in all four holes in the mounting plate.

2.6-Having drilled the 5/32" pilot holes for mounting to the joist, drill 1/4" clearance holes in the other two locations for the togglers. Now, insert the togglers into their appropriate holes. Tap gently into place. (See Fig. 8) Tighten the bolts until they are snug against the mounting plate—but not so tight that the bolt head causes the mounting plate to deform. Do not over-tighten the fasteners.

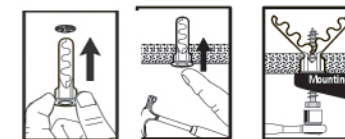

Fig. 8

3.1-Use the appropriate wrench for the shoulder nut. Hold the ball shaft with one hand and tighten the shoulder nut with the other.

JOINING THE CLAMP ASSEMBLY AND THE BALL SHAFT/MOUNTING PLATE

NOTE: You will need a second person (who we'll call "your assistant") to help lift and support the speaker.



Very important: When you tighten the clamp assembly, make sure there is no contact between the speaker and ball shaft.

As you orient and hold the speaker in position and tighten the tension screw, the only force acting upon the ball should be that of the clamp assembly compressing it. To accomplish this, the weight of the speaker must be supported fully, counteracting the forces of gravity that would otherwise act upon the assembly during tightening. Two installers are needed for this; one will support the speaker while the other tightens the clamp assembly. (See Fig. 9)

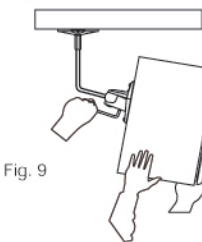

Fig. 9

Do not permit the ball shaft to rest upon or push against the clamp assembly. There should be no contact between the ball shaft and the clamp assembly components during the tightening procedure. Be sure to support the weight of the speaker. Do not permit the speaker to "hang" from the clamp assembly while you're tightening the tension screw. Be sure the clamp assembly is oriented in the proper direction, as indicated on the template in step 1.2.

4.1 Check again that the clamp assembly is open

enough to clear the ball. Get the 1/4" allen hex wrench. Have your assistant lift the speaker into position and "pop" the clamp assembly onto the ball.

While your assistant supports the weight of the speaker, insert the long end of the hex key. (See Fig. 10)

Fig. 10

Turn the hex tension screw clockwise to take up the slack in the clamp assembly, but do not tighten—the ball should be properly seated, and the speaker should still move easily).

ADJUSTING THE POSITION OF THE SPEAKER AND TIGHTENING THE CLAMP ASSEMBLY

5.1-Have your assistant orient and hold the speaker in its final position.

Helpful Hints: Use a carpenter's level to position the speaker parallel with the walls, floor or ceiling. To precisely focus a speaker's sound at a selected point in the listening area, try using a flashlight in a darkened room. With some masking tape, attach the flashlight to the top of the speaker facing out, over the front of the speaker enclosure (put a soft cloth underneath it to avoid scratches). Use the light beam to precisely image and focus the sound.



Caution: As you tighten the tension screw the only pressure on the ball should be that of the clamp assembly compressing it. Support the weight of the speaker. Ensure that there is no pressure from the force of gravity pulling or pushing on the ball. Ensure that the clamp assembly is not creating a lever by resting on or pushing against the ball shaft.

5.2-Now, insert the short end of the hex wrench. Start tightening the hex tension screw. (See Fig. 11)

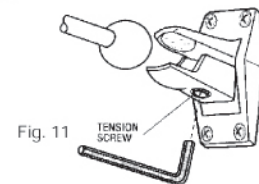

Fig. 11

How tight? To hold the speaker in position and prevent any slippage, the clamp assembly must get a good "bite" into the ball and form a solid joint. You need not be timid about the tightening procedure. Of course, it is possible to over-tighten and strip the threads on just about any screw—but it will take a lot to do so here. The OmniMount assembly is designed to withstand well in excess of the tightening force necessary for your speaker to hold position; yet the clamp assembly needs to be tightened only enough to lock and hold the speaker firmly at the chosen angle of adjustment. When that point is reached, no further tightening is necessary.

If the speaker loses its position—**do not attempt to move the speaker without first loosening the tension screw.** Reposition, then re-tighten the tension screw further until the speaker is held firmly in place.

Free Manuals Download Website

<http://myh66.com>

<http://usermanuals.us>

<http://www.somanuals.com>

<http://www.4manuals.cc>

<http://www.manual-lib.com>

<http://www.404manual.com>

<http://www.luxmanual.com>

<http://aubethermostatmanual.com>

Golf course search by state

<http://golfingnear.com>

Email search by domain

<http://emailbydomain.com>

Auto manuals search

<http://auto.somanuals.com>

TV manuals search

<http://tv.somanuals.com>