

**miConverter™ 10/100 Plus
Media Converter
User Manual**

miConverter 10/100 Plus Models					
Fiber Mode Type / Dual Fiber [DF] or Single-Fiber [SF]	Distance	Connector Types		Tx Lambda [nm]	Rx Lambda [nm]
		ST	SC		
MM / DF	5km	1120-0-x	1122-0-x	1310	1310
SM / DF	30km	1121-1-x	1123-1-x	1310	1310
SM / DF	60km	1121-2-x	1123-2-x	1310	1310
SM / DF	120km	-	1123-3-x	1550	1550
SM / SF	20km	-	1130-1-x	1310	1550
SM / SF	40km	-	1130-2-x	1310	1550
SM / SF	20km	-	1131-1-x	1550	1310
SM / SF	40km	-	1131-2-x	1550	1310

When choosing power options, replace (x) in the model number with the suffix number that corresponds to the power supply of choice below. Example: 1103-3-6 stands for 1103-3-x with USB Power Adapter

- 1 US Power Supply - 120Volt / 60Hz
- 2 Universal Power Supply (requires AC power cord) - 100-240Volt / 50-60Hz
- 3 Euro Power Supply - 100-240Volt / 50-60Hz
- 4 UK Power Supply - 100-240Volt / 50-60Hz
- 5 Australia Power Supply - 100-240Volt / 50-60Hz
- 6 USB Power Adapter Cable
- 8 US/JPN Power Supply - 100-240Volt / 50-60Hz

For power supplies -3, -4, -5 and -8, country/region specific clips are used to provide the necessary power connection.

UTP Mode Selection

The UTP port is configured using the DIP-switches as shown in Figure 1. There are four modes of operation based on the position of the DIP-switches. The factory default configuration is "AN" Auto-negotiation. In the "AN" mode, the port will advertise 100Mbps Full-Duplex, 100Mbps Half-Duplex, 10Mbps Full-Duplex and 10Mbps Half-Duplex.

The UTP port can be configured for Manual negotiation by setting the appropriate DIP-switches. The port can be configured for 100Mbps Full-Duplex, 100Mbps Half-Duplex and 10Mbps Half-Duplex.

Link Mode Selection

The miConverter 10/100 Plus can be configured for several different Link Modes. The DIP-switch illustration in Figure 1 indicates how to configure the different Link Modes.

Link Segment (LS)

"LS" (factory default) generates and detects a link signal at each point in the network. Utilizing this configuration, a loss of a receive link signal will only affect the port detecting the loss of signal. All the other ports will continue to generate a link signal. Figure 2(A) indicates the normal operation of the system without faults. Figure 2(B) indicates a loss of a receive link on the fiber optic port, the UTP port continues to maintain its link.

Accessories	
Wall Mounting Hardware Kit	4381
USB Power Adapter Cable	9130-2
US Domestic AC Power Adapter	9113-PS
Universal AC Power Adapter (requires AC power cord)	9115-PS
Europe AC Power Adapter	9116-PS-3
United Kingdom AC Power Adapter	9116-PS-4
Australia AC Power Adapter	9116-PS-5
Japanese AC Power Adapter	9116-PS-8
European Connector Clip*	9116-3
UK Connector Clip*	9116-4
Australian Connector Clip*	9116-5
Japanese Connector Clip*	9116-8

*All spare Connector Clips are interchangeable with AC Power Adapters 9116-PS-3, 9116-PS-4, 9116-PS-5 and 9116-PS-8

DESCRIPTION

The miConverter™ 10/100 Plus is a 10/100BASE-T copper to 100BASE-FX fiber media converter. The UTP copper port can automatically detect the speed, duplex mode and crossover mode of the connected device, or it can be manually configured via DIP-switches.

The 100BASE-FX fiber port operates in Full-Duplex mode and supports single-mode or multimode fiber with ST or SC fiber connectors. Single-mode models feature Bi-Directional fiber and support distances of up to 40km. The various fiber models options are described in the table on the first page.

Several Link Modes (fault-detection capabilities) are

Link Propagate (LP)

"LP" generates (transmits) a link signal only when a link signal is detected. Utilizing this configuration, a loss of a receive link signal will continue to 'propagate' through to the next port in the network. In Figure 2(C), a loss of a receive link on the fiber optic port causes the UTP port to drop its link due to the propagated fiber optic link state. This setting allows the loss of a link to be detected by SNMP or other managed network devices to which the miConverter 10/100 Plus is connected.

NOTE: Only the first loss of a receive link detected by the miConverter 10/100 Plus turns off the other port's transmit link. An additional loss of a receive link on the other port has no effect on the miConverter 10/100 Plus. The miConverter 10/100 Plus returns to normal operation when the first loss of a receive link is restored.

Remote Fault Detect + Link Segment (RFD + LS)

"RFD+LS" generates a link signal only when a link signal is detected. However, instead of propagating the fault forward, the loss of link is looped back. In Figure 2(D), a loss of a received link state is looped back causing the port to stop transmitted the link state. Because the other unit is configured for Link Propagate, the UTP port will drop its link due to the propagated fiber optic link state.

NOTE: It is not permitted to set both Converter A and B to RFD at the same time; a deadly embrace will occur.

available with the 10/100 Plus, including Link Segment (Normal Mode), Link Propagate (Link Loss Carry Forward), Remote Fault Detection and Symmetrical Fault Detection. The link mode assist in the identification and isolation of link failures.

WARNING!
Before inserting the Power Adapter, verify that the power on the unit is appropriate for your AC line voltage source.

POWER ADAPTER NOTICE

This product should only be used with Omnitron supplied Power Supply model numbers 9113-PS, 9115-PS, 9130-2, 9116-PS-3, 9116-PS-4, 9116-PS-5 or 9116-PS-8.

In order to guarantee performance when powering the miConverter 10/100 Plus with the USB Power Adapter cable (P/N 9130-2), the cable must be connected to a Full-Powered USB Type-A port (5V, 500mA).

NOTE: Not all USB Type-A ports are Full-Powered USB ports. The Full-Powered USB Type-A ports are usually the USB ports found on computer cases or on self-powered (powered by an AC adapter) USB hubs.

INSTALLATION PROCEDURE

1. Configure the miConverter 10/100 Plus with the appropriate DIP-switch settings. The factory default configuration for the UTP copper port is "AN" Auto-

Symmetrical Fault Detect (SFD)

"SFD" generates a Link Loss signal on all ports on both media converters when a loss of link signal is detected by one of the ports. In Figure 2(E), the pattern of LEDs gives an indication of the failure point.

NOTE: Both media converters must be configured with the SFD Link Mode. The SFD function is only supported by Omnitron Systems equipment.

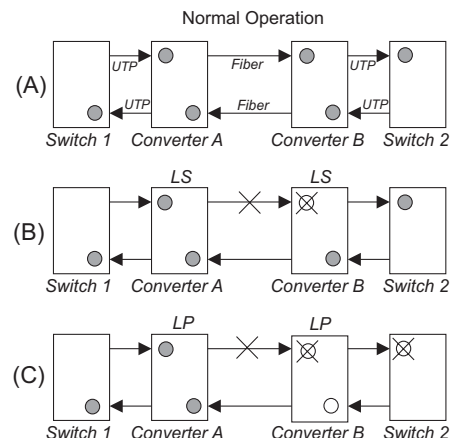

● LED ON ⊗ LED OFF
 ✨ LED Flashing ○ LED ON or OFF
 ○ - LED status depends on the link type; AN - OFF, MAN - ON

Figure 2: Link Modes

negotiation and the Link Mode is "LS" Link Segment.

2. Connect the UTP port to a 10BASE-T or 100BASE-TX Ethernet device using a Category 5 cable (or better).
3. Connect the fiber optic port to a 100BASE-FX Fast Ethernet device via the fiber cable of the appropriate mode and type. When connecting dual fiber models, the miConverter 10/100 Plus transmitter (Tx) must attach to the receiver side of its link partner; the receiver (Rx) must attach to the transmitter. When connecting single-fiber (SF) models, the Tx wavelength on one end has to match the Rx wavelength on the other. Based on this guideline, the SF media converter models must be used in pairs, such as the 1130-2-x matched with the 1131-2-x.
4. Mount the miConverter 10/100 Plus using the included Velcro® strips or optional wall-mounting bracket kit (P/N 1091-0).
5. Connect the appropriate power source.

DIP-SWITCH SETTINGS

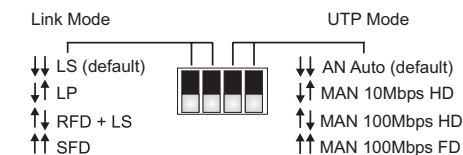

Figure 1: DIP-switch Configurations

LED INDICATORS:

Function	Legend	Color	Off	On
Power	Pwr	Amber	No power	Power applied
F/O Link-Act	F/O	Green	No link	Solid = Link Rapid Blinking (10Hz) = Data Slow Blinking (5Hz) = SFD Error Det.
UTP Link-Act	UTP	Green	No link	Solid = Link Rapid Blinking (10Hz) = Data Slow Blinking (5Hz) = SFD Error Det.
10(Off) / 100(On)	100	Green	UTP = 10Mbps when UTP Link is active	UTP = 100Mbps when UTP Link is active
HDX(Off) / FDX(On)	FDX	Green	Half-Duplex when UTP Link is active	Full-Duplex when UTP Link is active

NOTE: For additional assistance with the LED indicators, please refer to the *miConverter* 10/100 Plus TROUBLESHOOTING GUIDE (pp 12 -13).

Page 9

is established, the Link Mode selection can be modified.

Problem:

The UTP link LED does not illuminate after installation is complete.

Possible Causes:

A. Confirm that the UTP cable is connected properly to the *miConverter* 10/100 Plus and the attached UTP device.

B. Confirm that the UTP cable pin-out is correct (EIA/TIA-568-A).

C. Verify the *miConverter* 10/100 Plus UTP port is configured with the proper settings based on the attached device (AN or MAN, 10 or 100, HD or FD).

NOTE: If corrective actions do not resolve your situation, please contact Omnitron Systems Technical Support.

Page 13

SPECIFICATIONS:

<i>miConverter</i> 10/100 Plus Specifications	
Description	Miniature 10/100BASE-T Copper to 100BASE-FX Fiber Media Converter
Protocols	10BASE-T, 100BASE-TX, 100BASE-FX with 1536 bytes max. frame size, IEEE 802.3 specification
Cable Types	
UTP	EIA/TIA 568A/B, Category 5 and higher
Fiber	Multimode: 50/125, 62.5/125, 100/140 um Single-mode: 9/125 um
Connector Types	
UTP	RJ45
Fiber	Dual fiber: SC, ST Single-fiber: SC
LED Displays	Pwr, FO-Lk/Act, UTP-Lk/Act, UTP-10/100, HDX/FDX
Power Requirements	
DC Power	0.5A @ 5VDC
DC Power Connector	2.5mm DC Jack - Center Positive
AC Power Adapter [US]	100-120VAC/60Hz 0.03A @ 120VAC
AC Power Adapter [Universal or Country/Region Specific]	100-240VAC/50-60Hz 0.03A @ 120VAC

Page 10

Warning

The operating description in this Instruction Manual is for use by qualified personnel only. To avoid electrical shock, do not perform any servicing of this unit other than that contained in the operating instructions, unless you are qualified and certified to do so by Omnitron Systems Technology, Inc.

Warranty

This product is warranted to the original purchaser against defects in material and workmanship for a period of TWO YEARS from the date of shipment. A LIFETIME warranty may be obtained by the original purchaser by REGISTERING this product with Omnitron within 90 days from the date of shipment. TO REGISTER, COMPLETE AND MAIL OR FAX THE ENCLOSED REGISTRATION FORM TO THE INDICATED ADDRESS. Or you may register your product on the Internet at <http://www.omnitron-systems.com>. During the warranty period, Omnitron will, at its option, repair or replace a product which is proven to be defective.

For warranty service, the product must be sent to an Omnitron designated facility, at Buyer's expense. Omnitron will pay the shipping charge to return the product to Buyer's designated US address using Omnitron's standard shipping method.

Page 14
Download from www.Somanuals.com. All Manuals Search And Download.

SPECIFICATIONS (CONT.):

Dimensions	W:1.71" x L:4.10" x H:0.84"
Weight	
without power adapter	4 oz.
with USB power adapter cable	5 oz.
with AC power adapter [US]	12 oz.
with AC power adapter [Universal]	18 oz.
Compliance	UL, CE, FCC Class A
Temperature	
Operational - Commercial	0 to +50°C
Storage	-50 to +80°C
Humidity (non-condensing)	5% to 95%
Altitude	-100m to 4000m
MTBF [hrs]	
without power adapter	1,000,000
with US or Country/Region Specific power adapter	250,000
with Universal power adapter	100,000

Page 11

Limitation of Warranty

The foregoing warranty shall not apply to defects resulting from improper or inadequate use and/or maintenance of the equipment by Buyer, Buyer-supplied equipment, Buyer-supplied interfacing, unauthorized modifications or tampering with equipment (including removal of equipment cover by personnel not specifically authorized and certified by Omnitron), or misuse, or operating outside the environmental specification of the product (including but not limited to voltage, ambient temperature, radiation, unusual dust, etc.), or improper site preparation or maintenance.

No other warranty is expressed or implied. Omnitron specifically disclaims the implied warranties of merchantability and fitness for any particular purpose.

Exclusive Remedies

The remedies provided herein are the Buyer's sole and exclusive remedies. Omnitron shall not be liable for any direct, indirect, special, incidental, or consequential damages, whether based on contract, tort, or any legal theory.

TROUBLESHOOTING GUIDE:

Problem:

The Power LED does not illuminate after installation is complete.

Possible Causes:

A. Confirm that the power supply is connected.

B. Confirm that the correct power supply is being used.

Problem:

The Fiber Optic link LED does not illuminate after installation is complete.

Possible Causes:

A. Confirm that the fiber optic cable is properly connected to the *miConverter* 10/100 Plus and the remote fiber optic device.

B. Confirm that the fiber cable type matches the fiber transceiver type (multimode, single-mode) on the *miConverter* 10/100 Plus.

C. If using a dual-fiber model, confirm that the transmitter (Tx) is attached to the receiver side of its link partner, and that the receiver (Rx) is attached to the transmitter.

D. If using a single-fiber model, confirm that the Tx wavelength on the *miConverter* 10/100 Plus matches the Rx of the connected fiber optic device.

E. Verify the Link Mode selection is set to Link Segment (LS). Until a stable link is established, leave the Link Mode configured for LS. After a Link presence

Page 12

TECHNICAL SUPPORT:

For help with this product, contact Omnitron's Tech. Support:

Phone: (949) 250-6510

Fax: (949) 250-6514

Address: Omnitron Systems Technology, Inc.
140 Technology #500
Irvine, CA 92618 USA

E-mail: support@omnitron-systems.com

URL: <http://www.omnitron-systems.com>

Form: 040-11200-001 B 11/07

Page 16

Free Manuals Download Website

<http://myh66.com>

<http://usermanuals.us>

<http://www.somanuals.com>

<http://www.4manuals.cc>

<http://www.manual-lib.com>

<http://www.404manual.com>

<http://www.luxmanual.com>

<http://aubethermostatmanual.com>

Golf course search by state

<http://golfingnear.com>

Email search by domain

<http://emailbydomain.com>

Auto manuals search

<http://auto.somanuals.com>

TV manuals search

<http://tv.somanuals.com>