

ONKYO®

Audio Video Karaoke Control Receiver

TX-SE550

Instruction Manual

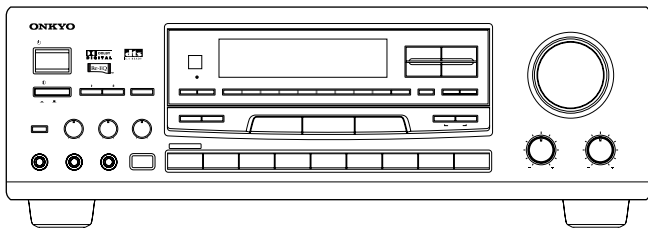

Thank you for purchasing the Onkyo Audio Video Karaoke Control Receiver.

Please read this manual thoroughly before making connections and turning on the power.

Following the instructions in this manual will enable you to obtain optimum performance and listening enjoyment from your new Audio Video Karaoke Control Receiver.

Please retain this manual for future reference.

Contents

Before using

Important Safeguards.....	2
Precautions	3
Features.....	4
Supplied accessories.....	4
Before operating this unit.....	5

Preparation

Audio equipment connections	6
Video equipment connections	7
Connecting other devices	8
Connecting speakers.....	10
Positioning speakers.....	11
Connecting the power.....	11
Making antenna connections	12

Operation

Speaker setup.....	14
Selecting a sound source	16
To enjoy Surround mode or Stereo mode	20
Karaoke function	22
Tuning in a radio station.....	24
Using preset radio stations.....	25
Recording a source	26
Programming remote controller codes	28

Appendix

Troubleshooting guide.....	30
Specifications	31

Control guide

Control positions and names	32
Remote controller RC-386M.....	33
Using the remote controller.....	34

WARNING:

TO REDUCE THE RISK OF FIRE OR ELECTRIC SHOCK, DO NOT EXPOSE THIS APPLIANCE TO RAIN OR MOISTURE.

CAUTION:

TO REDUCE THE RISK OF ELECTRIC SHOCK, DO NOT REMOVE COVER (OR BACK). NO USER-SERVICEABLE PARTS INSIDE. REFER SERVICING TO QUALIFIED SERVICE PERSONNEL.



WARNING
RISK OF ELECTRIC SHOCK
DO NOT OPEN

AVIS
RISQUE DE CHOC ELECTRIQUE
NE PAS OUVRIR



The lightning flash with arrowhead symbol, within an equilateral triangle, is intended to alert the user to the presence of uninsulated "dangerous voltage" within the product's enclosure that may be of sufficient magnitude to constitute a risk of electric shock to persons.



The exclamation point within an equilateral triangle is intended to alert the user to the presence of important operating and maintenance (servicing) instructions in the literature accompanying the appliance.

Important Safeguards

- Read Instructions** – All the safety and operating instructions should be read before the appliance is operated.
- Retain Instructions** – The safety and operating instructions should be retained for future reference.
- Heed Warnings** – All warnings on the appliance and in the operating instructions should be adhered to.
- Follow Instructions** – All operating and use instructions should be followed.
- Water and Moisture** – The appliance should not be used near water – for example, near a bathtub, washbowl, kitchen sink, laundry tub, in a wet basement, or near a swimming pool, and the like.
- Carts and Stands** – The appliance should be used only with a cart or stand that is recommended by the manufacturer.

PORTABLE CART WARNING



S3125A
- Wall or Ceiling Mounting** – The appliance should be mounted to a wall or ceiling only as recommended by the manufacturer.
- Ventilation** – The appliance should be situated so that its location or position does not interfere with its proper ventilation. For example, the appliance should not be situated on a bed, sofa, rug, or similar surface that may block the ventilation openings; or if placed in a built-in installation, such as a bookcase or cabinet that may impede the flow of air through the ventilation openings, there should be free space of at least 20 cm (8 in.) and an opening behind the appliance.
- Heat** – The appliance should be situated away from heat sources such as radiators, heat registers, stoves, or other appliances (including amplifiers) that produce heat.
- Power Sources** – The appliance should be connected to a power supply only of the type described in the operating instructions or as marked on the appliance.
- Polarization** – If the appliance is provided with a polarized plug having one blade wider than the other, please read the following information:
The polarization of the plug is a safety feature. The polarized plug will only fit the outlet one way. If the plug does not fit fully into the outlet, try reversing it. If there is still trouble, the user should seek the services of a qualified electrician. Under no circumstances should the user attempt to defeat the polarization of the plug.
- Power-Cord Protection** – Power-supply cords should be routed so that they are not likely to be walked on or pinched by items placed upon or against them, especially near plugs, convenience receptacles, and the point where they exit from the appliance.
- Cleaning** – The appliance should be cleaned only as recommended by the manufacturer.
- Power Lines** – An outdoor antenna should be located away from power lines.
- Nonuse Periods** – The power cord of the appliance should be unplugged from the outlet when left unused for a long period of time.
- Object and Liquid Entry** – Care should be taken so that objects do not fall and liquids are not spilled into the enclosure through openings.
- Damage Requiring Service** – The appliance should be serviced by qualified service personnel when:
 - The power-supply cord or the plug has been damaged; or
 - Objects have fallen, or liquid has been spilled into the appliance; or
 - The appliance has been exposed to rain; or
 - The appliance does not appear to operate normally or exhibits a marked change in performance; or
 - The appliance has been dropped, or the enclosure damaged.
- Servicing** – The user should not attempt to service the appliance beyond that described in the operating instructions. All other servicing should be referred to qualified service personnel.
- Outdoor Antenna Grounding** – If an outside antenna is connected to the receiver, be sure the antenna system is grounded so as to provide some protection against voltage surges and built up static charges. Article 810 of the National Electrical Code, ANSI/NFPA 70, provides information with regard to proper grounding of the mast and supporting structure, grounding of the lead-in wire to an antenna-discharge unit, size of grounding conductors, location of antenna-discharge unit, connection to grounding electrodes, and requirements for the grounding electrode. See Figure 1.

FIGURE 1:
EXAMPLE OF ANTENNA GROUNDING AS PER NATIONAL ELECTRICAL CODE

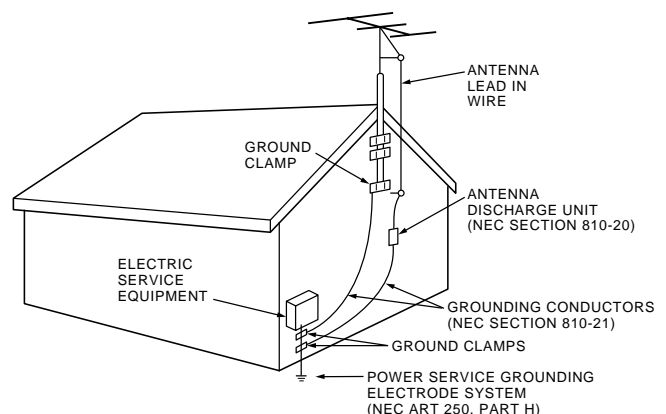

NEC – NATIONAL ELECTRICAL CODE

S2898A

Precautions

1. Warranty Claim

You can find the serial number on the rear panel of this unit. In case of warranty claim, please report this number.

2. Recording Copyright

Recording of copyrighted material for other than personal use is illegal without permission of the copyright holder.

3. AC Fuse

The fuse is located inside the chassis and is not user-serviceable. If power does not come on, contact your Onkyo authorized service station.

4. Care

From time to time you should wipe the front and rear panels and the cabinet with a soft cloth. For heavier dirt, dampen a soft cloth in a weak solution of mild detergent and water, wring it out dry, and wipe off the dirt. Following this, dry immediately with a clean cloth. Do not use rough material, thinners, alcohol or other chemical solvents or cloths since these could damage the finish or remove the panel lettering.

5. Power

WARNING

BEFORE PLUGGING IN THE UNIT FOR THE FIRST TIME, READ THE FOLLOWING SECTION CAREFULLY.

The voltage of the available power supply differs according to country or region. Be sure that the power supply voltage of the area where this unit will be used meets the required voltage (e.g., AC 230 V, 50 Hz or AC 120 V, 60 Hz) written on the rear panel.

Worldwide models are equipped with a voltage selector to conform to local power supplies. Be sure to set this switch to match the voltage of the power supply in your area before plugging in the unit.

For British model

Replacement and mounting of an AC plug on the power supply cord of this unit should be performed only by qualified service personnel.

IMPORTANT

The wires in the mains lead are coloured in accordance with the following code:

Blue : Neutral

Brown : Live

As the colours of the wires in the mains lead of this apparatus may not correspond with the coloured markings identifying the terminals in your plug, proceed as follows:

The wire which is coloured blue must be connected to the terminal which is marked with the letter N or coloured black.

The wire which is coloured brown must be connected to the terminal which is marked with the letter L or coloured red.

IMPORTANT

A 5 amp fuse is fitted in this plug. Should the fuse need to be replaced, please ensure that the replacement fuse has a rating of 5 amps and that it is approved by ASTA or BSI to BS1362. Check for the ASTA mark or the BSI mark on the body of the fuse.

IF THE FITTED MOULDED PLUG IS UNSUITABLE FOR THE SOCKET OUTLET IN YOUR HOME THEN THE FUSE SHOULD BE REMOVED AND THE PLUG CUT OFF AND DISPOSED OF SAFELY. THERE IS A DANGER OF SEVERE ELECTRICAL SHOCK IF THE CUT OFF PLUG IS INSERTED INTO ANY 13 AMP SOCKET.

If in any doubt, please consult a qualified electrician.

For U.S. model

Note to CATV system installer:

This reminder is provided to call the CATV system installer's attention to Article 820-40 of the NEC, ANSI/NFPA 70, which provides guidelines for proper grounding and, in particular, specifies that the cable ground shall be connected to the grounding system of the building, as close to the point of cable entry as practical.

FCC Information for User

CAUTION:

The user changes or modifications not expressly approved by the party responsible for compliance could void the user's authority to operate the equipment.

NOTE:

This equipment has been tested and found to comply with the limits for a Class B digital device, pursuant to Part 15 of the FCC Rules. These limits are designed to provide reasonable protection against harmful interference in a residential installation. This equipment generates, uses and can radiate radio frequency energy and, if not installed and used in accordance with the instructions, may cause harmful interference to radio communications. However, there is no guarantee that interference will not occur in a particular installation. If this equipment does cause harmful interference to radio or television reception, which can be determined by turning the equipment off and on, the user is encouraged to try to correct the interference by one or more of the following measures:

- Reorient or relocate the receiving antenna.
- Increase the separation between the equipment and receiver.
- Connect the equipment into an outlet on a circuit different from that to which the receiver is connected.
- Consult the dealer or an experienced radio/TV technician for help.

For Canadian model

CAUTION: THIS DIGITAL APPARATUS DOES NOT EXCEED THE CLASS B LIMITS FOR RADIO NOISE EMISSION FROM DIGITAL APPARATUS SET OUT IN THE RADIO INTERFERENCE REGULATIONS OF THE CANADIAN DEPARTMENT OF COMMUNICATIONS.

For models having a power cord with a polarized plug:

CAUTION: TO PREVENT ELECTRIC SHOCK, MATCH WIDE BLADE OF PLUG TO WIDE SLOT, FULLY INSERT.

Modele pour les Canadien

ATTENTION: L'INTERFÉRENCE RADIO ÉLECTRIQUE GÉNÉRÉE PAR CET APPAREIL NUMÉRIQUE DE TYPE B NE DÉPASSE PAS LES LIMITES ÉNONCÉES DANS LE RÈGLEMENT SUR LES PERTURBATIONS RADIO ÉLECTRIQUES, SECTION APPAREIL NUMÉRIQUE, DU MINISTÈRE DES COMMUNICATIONS.

Sur les modèles dont la fiche est polarisée:

ATTENTION: POUR ÉVITER LES CHOCS ÉLECTRIQUES, INTRODUIRE LA LAME LA PLUS LARGE DE LA FICHE DANS LA BORNE CORRESPONDANTE DE LA PRISE ET POUSSER JUSQU'AU FOND.

Declaration of Conformity

We, ONKYO EUROPE
ELECTRONICS GmbH
INDUSTRIESTRASSE 20
82110 GERMERING,
GERMANY



declare in own responsibility, that the ONKYO product described in this instruction manual is in compliance with the corresponding technical standards such as EN60065, EN55013, EN55020 and EN61000-3-2, -3-3 (or EN60555-2, -3).

GERMERING, GERMANY

K. OTSU

ONKYO EUROPE ELECTRONICS GmbH

Features

Amplifier Features

- 100 Watts MAXIMUM POWER to each of the five channels into 6 ohms at 1 kHz (EIAJ) — enough solid, clean power to drive your home theater speakers with authority and produce dynamically rich music, even at low volume levels, and more than enough for a thrilling home theater experience in most entertainment rooms.
- COSTLY DISCRETE OUTPUT STAGE CIRCUITRY
- HIGH-CURRENT LOW-IMPEDANCE 6-OHM DRIVE for all five channels.

Audio/Video Features

- POWERED BY MOTOROLA 24-BIT DSP, the DSP56009, which runs at 88 MHz, and can execute 44 million instructions per second (MIPS) for greater processing capacity that translates into better dynamics, more reflections and more reverberations — parameters that define how real everything will sound — also gives you more control over factors specific to your home theater, such as room size, ambiance, equalization and time delay.
- DOLBY* DIGITAL PROCESSOR BUILT-IN to decode the 5.1 channel pristine digital audio on DVDs, HDTV and other sources.
- CINEMA RE-EQ™ CIRCUITRY**

FM/AM Tuner Features

- 30 FM/AM RANDOM PRESETS — especially convenient if there are a lot of radio stations in your area. You can assign a number, in any order, to each of your favorite FM and AM stations, then access them simply at the touch of a button.
- 3 STATION-GROUP PRESETS
- FM AUTO TUNING to quickly and easily find FM stations in the area.

Other Features You'll Enjoy

- PRECISION VOLUME CONTROL to eliminate the noise and distortion inherent in electronic switching, and give you more precise, minute volume-level adjustment by remote.
- KARAOKE CAPABILITY with 2 microphone inputs, each with its own volume control, plus Digital Echo, Digital Key (pitch) control and for more professional sounding karaoke.
- BANANA PLUG-COMPATIBLE MULTIWAY SPEAKER BINDING

*Manufactured under license from Dolby Laboratories.

"Dolby", "Pro Logic" and the double-D symbol  are trademarks of Dolby Laboratories. Confidential Unpublished Works. ©1992-1997 Dolby Laboratories, Inc. All rights reserved.

**Re-Equalization™ is a trademark of Lucasfilm Ltd.

Supplied accessories

Check that the following accessories are supplied with this unit.

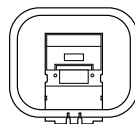

AM loop antenna × 1

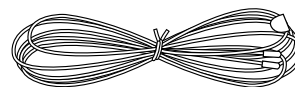

T-shaped FM antenna × 1

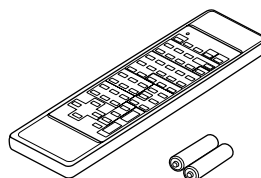

Remote controller (RC-386M) × 1
Batteries (size AA or UM-3) × 2

The following accessories are only available for worldwide models.

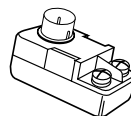

75/300 ohm antenna
adapter × 1

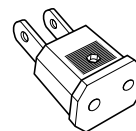

Conversion plug (Shape may vary depending on the area which it was purchased.) × 1

Memory Preservation

This unit does not require memory preservation batteries. A built-in memory power back-up system preserves the contents of the memory during power failures and even when the unit is unplugged. The unit must be plugged in order to charge the back-up system.

The memory preservation period after the unit has been unplugged varies depending on climate and placement of the unit. On the average, memory contents are protected over a period of a few weeks after the last time the unit has been unplugged. This period is shorter when the unit is exposed to a highly humid climate.

Before operating this unit

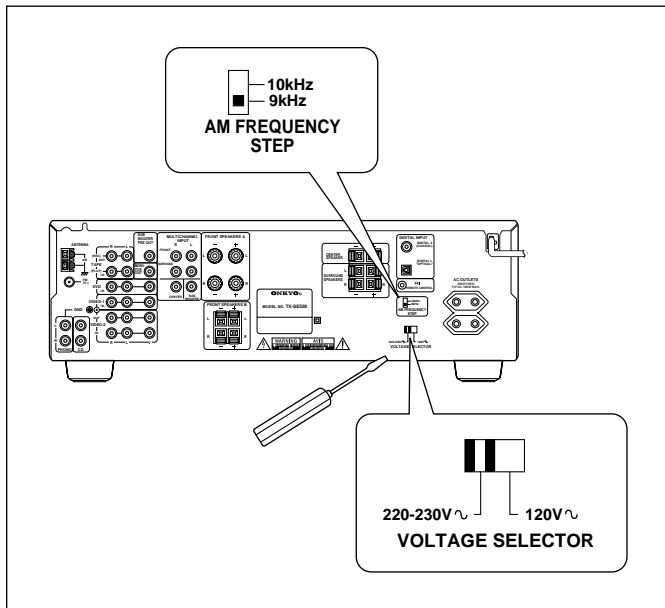

Setting the AM tuning step frequency (Worldwide models only)

Worldwide models are equipped with a switch that controls the AM band tuning steps. Please set this switch to match the AM band tuning step frequency in your area.

U.S.A. and Canada : 10 kHz
Other areas : 9 kHz

Setting the Voltage selector (Worldwide models only)

Worldwide models are equipped with a voltage selector to conform with local power supplies. Be sure to set this switch to match the voltage of the power supply in your area before plugging in the unit.

1. Determine the proper voltage for your area: 220-230 V or 120 V.
2. If the preset voltage is not correct for your area, insert a screwdriver into the groove in the switch. Slide the switch all the way to the right (120 V) or to the left (220-230 V), whichever is appropriate.

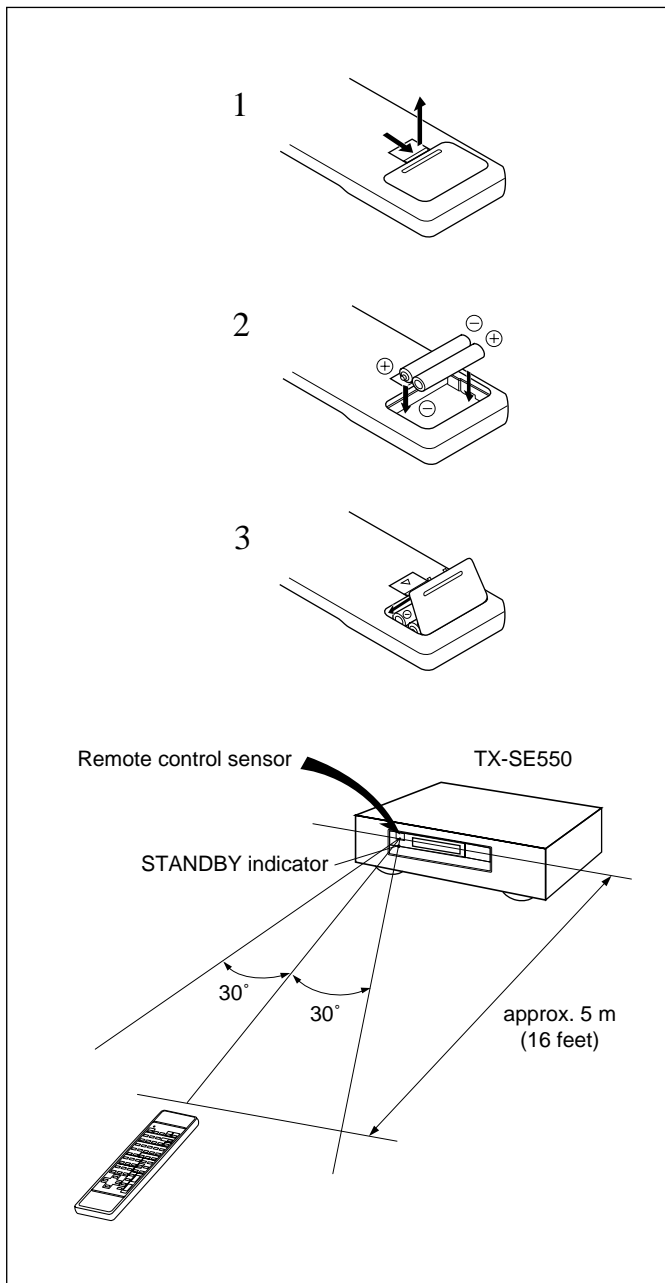

Installing the remote controller batteries

1. Remove the battery compartment cover by pressing the tab and lifting up the cover.
2. Insert two AA (R6- or UM-3-) size batteries into the battery compartment. Carefully follow the polarity diagram (positive (+) and negative (-) symbols) inside the battery compartment.
3. After batteries are installed and seated correctly, replace the compartment cover.

Notes

- Do not mix new batteries with old batteries or different kinds of batteries.
- To avoid corrosion, remove the batteries if the remote controller is not to be used for a long time.
- Remove dead batteries immediately to avoid damage from corrosion. If the remote controller doesn't operate smoothly, replace both the batteries at the same time.
- The life of the batteries supplied is about six months but this will vary depending on usage.

Using the remote controller

Point the remote controller toward the remote control sensor. The STANDBY indicator lights up when the unit receives a signal from the remote controller.

Notes

- Place the unit away from strong light such as direct sunlight or inverted fluorescent light which can prevent proper operation of the remote controller.
- Using another remote controller of the same type in the same room or using the unit near equipment which uses infrared rays may cause operational interference.
- Do not put any object such as a book on the remote controller. The buttons of the remote controller may be pressed by mistake and drain the batteries.
- Make sure the audio rack doors do not have colored glass. Placing the unit behind such doors may prevent proper remote controller operation.
- If there is any obstacle between the remote controller and the remote control sensor, the remote controller will not operate.

Audio equipment connections

- On each pair of input jacks, a red connector (marked R) corresponds to the right channel, and a white connector (marked L) to the left channel.
- Please refer to the instruction manual of each component when making any connections.
- This receiver is designed for use with turntables using moving magnet cartridges.
- Insert the plugs and connectors securely. Remember that improper connection can result in noise, poor performance, or damage to the equipment.

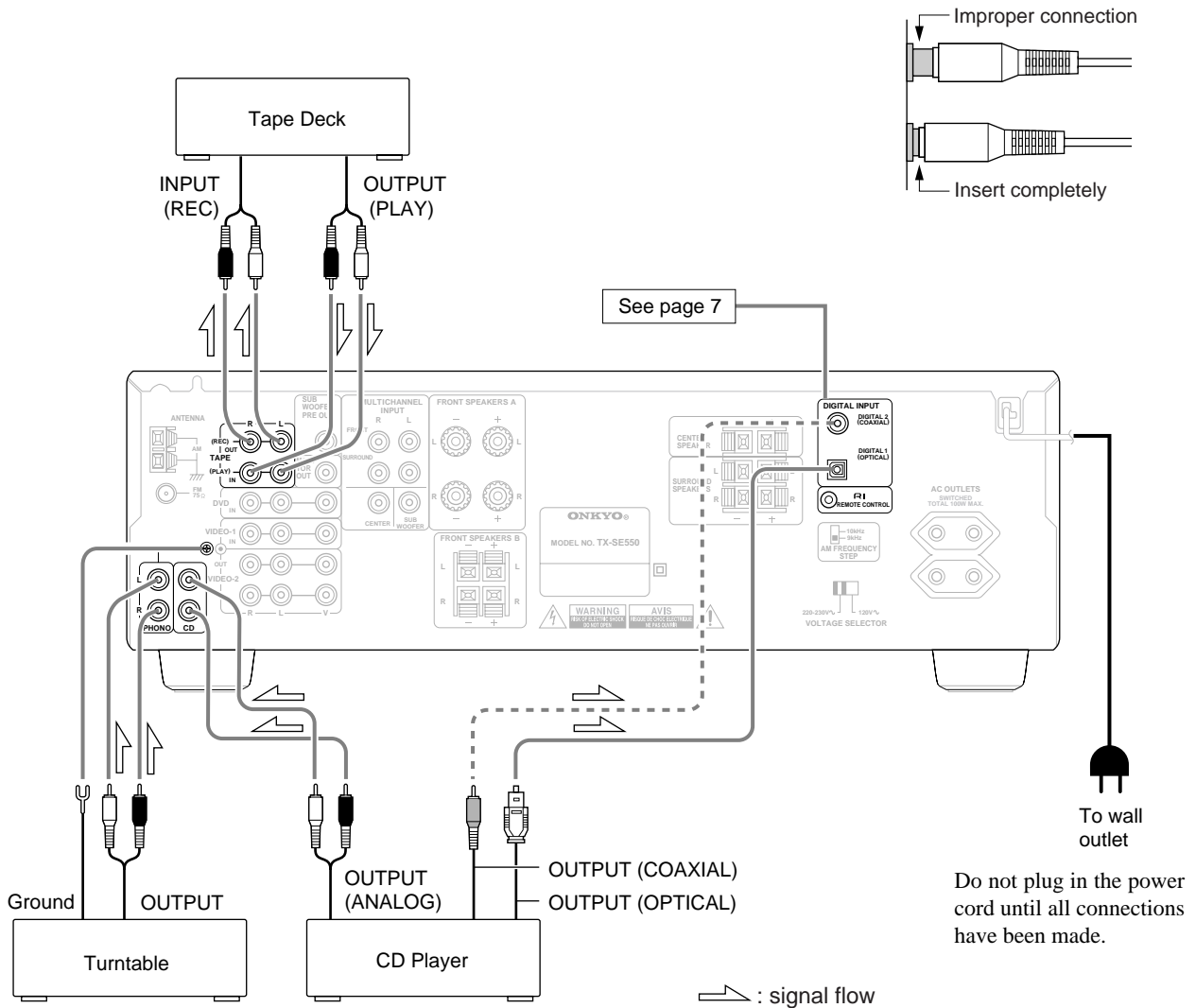
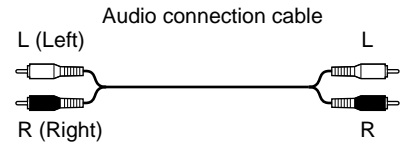

- A DVD or other component equipped with a digital output can be connected to this receiver. The digital connection must be used in conjunction with an analog connection, because if the analog cable is disconnected, the audio output from TAPE OUT, VIDEO-2 and AUDIO OUT will not work.

Video equipment connections

- On each pair of input jacks, a red connector (marked R) corresponds to the right channel, and a white connector (marked L) to the left channel.
- A yellow connector (marked V) is used for video connection.
- Please refer to the instruction manual of each component when making any connections.

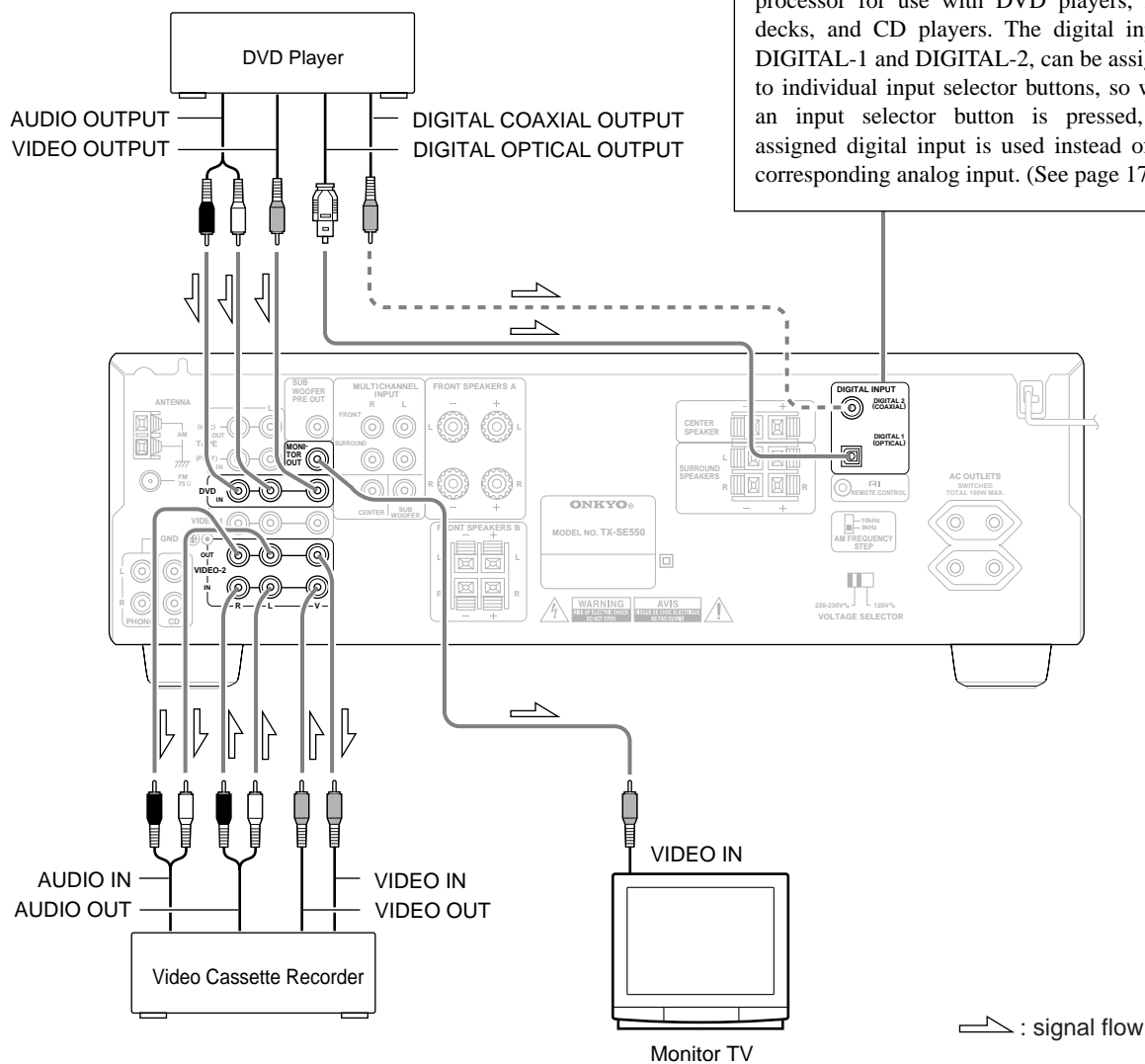
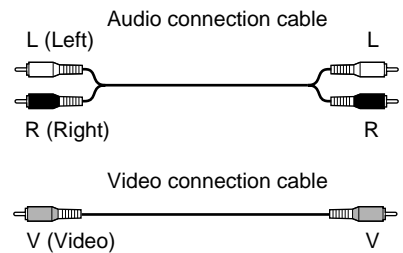

Notes:

- When using a playback-only VCR, you need to make only the output connections.
- This receiver can be used with only a monitor TV equipped with a video input jack.
- Interference may be caused between the TV and this receiver. If this interference occurs, place the receiver and the TV as far apart as possible. We do not recommend the use of a common TV/FM antenna (see antenna section).
- A DVD or other component equipped with a digital output can be connected to this receiver. The digital connection must be used in conjunction with an analog connection, because if the analog cable is disconnected, the audio output from TAPE OUT, VIDEO-2 and AUDIO OUT will not work.
- Remove the protective cap attached to the DIGITAL-1 (OPTICAL) jack before making the connection. When this jack is not used, replace the protective cap.

Connecting other devices

- On each pair of input jacks, a red connector (marked R) corresponds to the right channel, and a white connector (marked L) to the left channel.
- A yellow connector (marked V) is used for video connection.
- Please refer to the instruction manual of each component when making any connections.

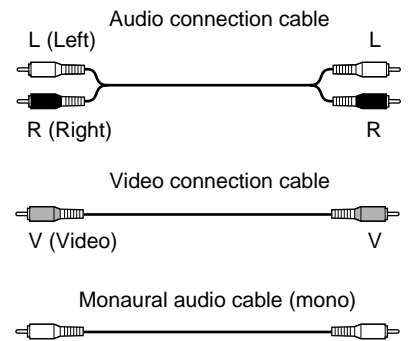

decoder with 5.1 channel output

You may connect the 5.1 channel outputs of an external decoder (such as DTS decoder or MPEG decoder) to the MULTICHANNEL INPUTS of this unit.

Use the DVD player or decoder controls to adjust the speaker settings for multi-channel input.

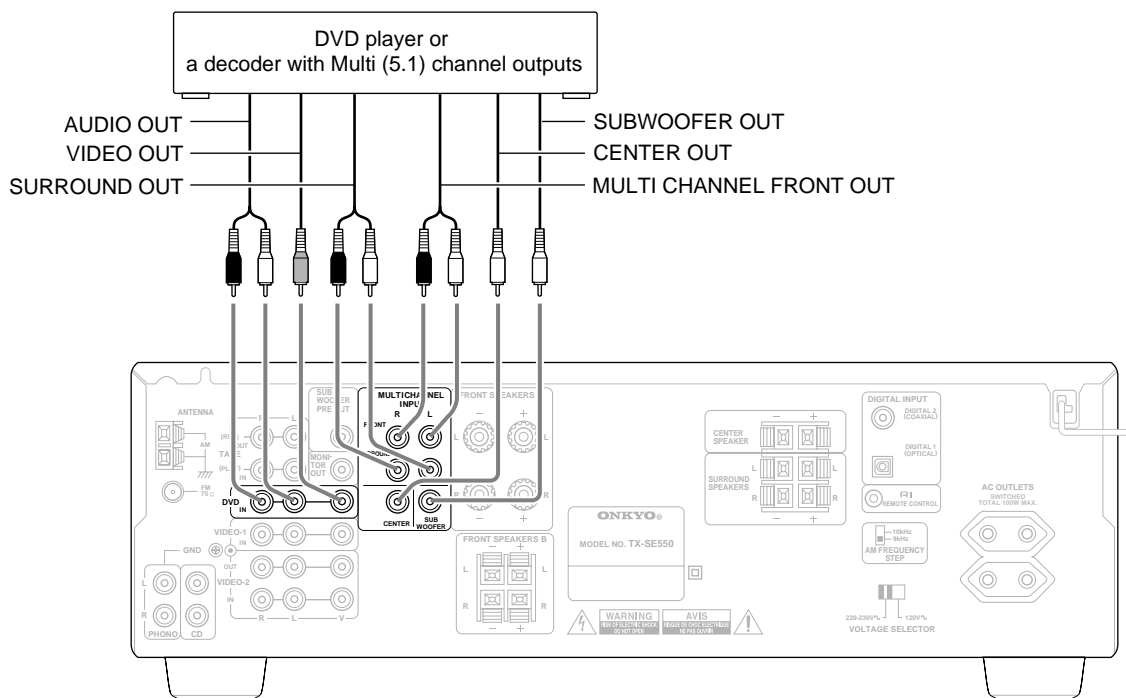

Connecting other devices

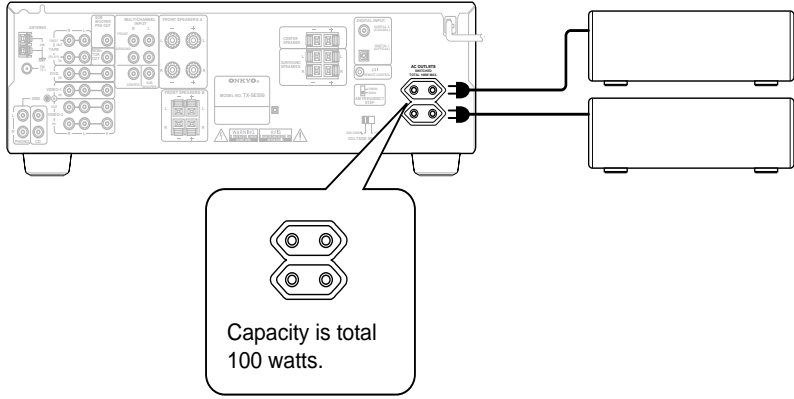

AC outlet connection

You can connect the power cord from another audio device to the rear of this receiver. Since the AC outlets on the unit are a SWITCHED type outlet, you can use the STANDBY/ON button, or the POWER button on the remote controller to turn on/off the power to both this receiver and the connected audio devices.

First turn the POWER switch ON ( ON).

The shape, number, and total capacity of the AC outlets may differ depending on the area of purchase. Make sure that the total capacity of other components connected to this unit does not exceed the capacity that is printed on the rear panel.

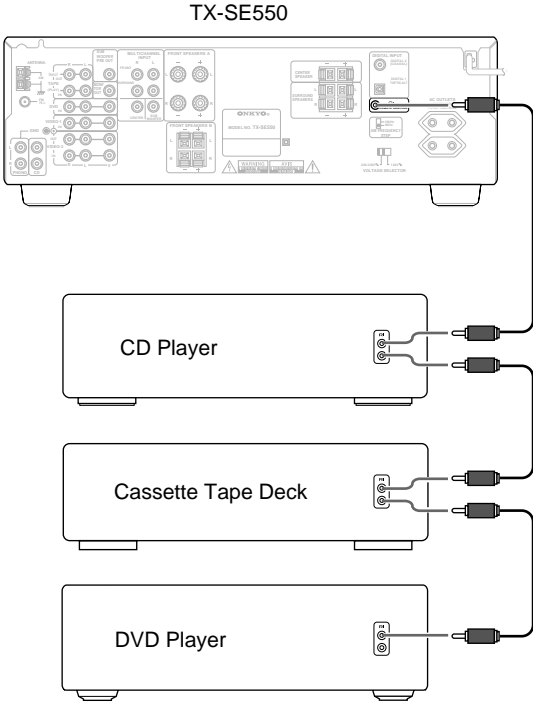

Connections for remote control (RI)

You can use the remote controller of this receiver to operate cassette tape decks, compact disc players and DVD players that have Onkyo **RI** connectors.

Connect a remote control cable to the connector with the **RI** mark.

- An **RI** remote control cable equipped with a 3.5mm (1/8 in.)-diameter miniature two-conductor phone plug comes with every compact disc player, cassette tape deck, or DVD player that has an **RI** connector.
- Remote control operation is not possible if only the remote control cable is connected – the audio connection cables must also be connected.
- This receiver's remote controller does not support control of Onkyo turntables.
- If the connecting device has two **RI** connectors lined-up vertically or horizontally, you can use either of them. They both offer the same functionality.

Connecting speakers

- If you want to use the surround effects, connect surround speakers. For the best results, connect a center speaker.
- Use FRONT SPEAKERS B terminals to connect a second pair of front speakers.
- This receiver is designed to produce optimum sound quality when speakers with impedances within the specified ranges are connected. Please check the following information and choose speakers with appropriate impedances for the connections.

FRONT SPEAKERS: A or B: 6 ohms min./speaker
SURROUND SPEAKERS: 6 ohms min./speaker
CENTER SPEAKER: 6 ohms min.

Connecting the speaker cable

1. Twist wire ends very tight.

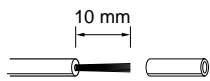

2. Unscrew.



3. Insert wire.

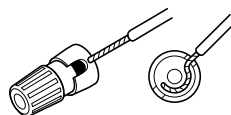

4. Screw.



2. Press down the lever.

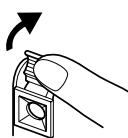

3. Insert the wire into the hole.

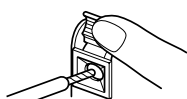

4. Release the lever to replace it.



NOTE:

To prevent damage to circuitry, never short-circuit the positive (+) and negative (-) speaker wire.

NO

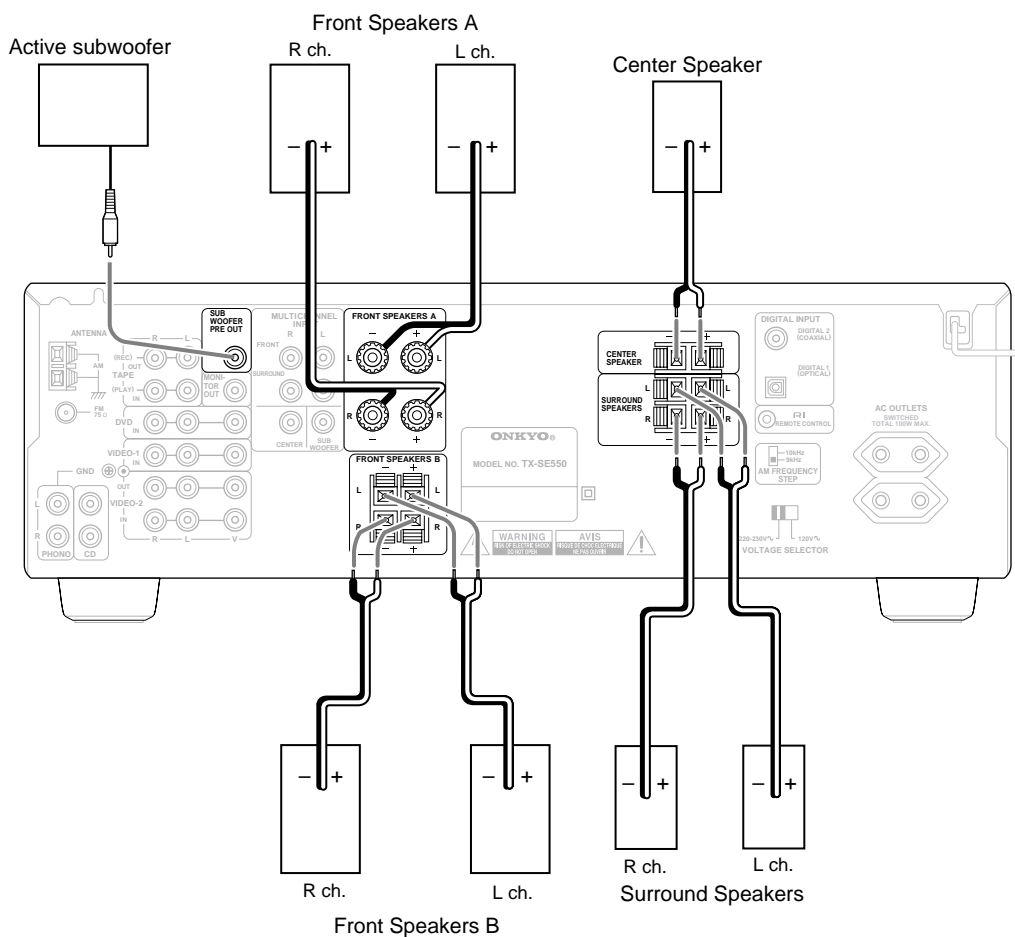
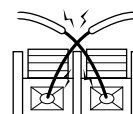

- When you use only one speaker or wish to listen

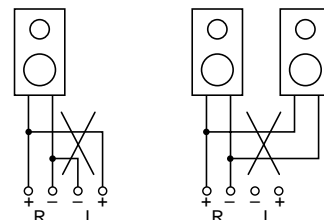

Positioning speakers

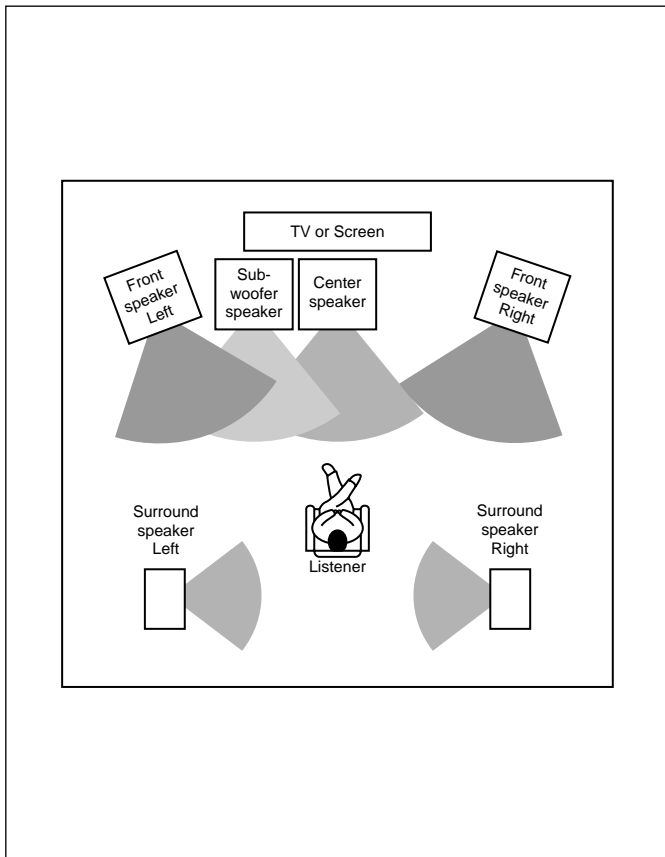

Positioning speakers

Speaker placement plays an important role in the reproduction of Surround sound. The placement of the speakers varies depending on the size of the room and the wall coverings used in the room. The illustration shows an example of a layout for standard speaker placement. Refer to this example when you position the speakers in order to experience the best of Surround sound.

Standard speaker placement

For ideal Surround effects, all speakers should be installed. If a center speaker or subwoofer is not connected, the sound from the unused channel is properly distributed to the connected speakers in order to produce the best Surround sound possible.

Front: The left, right, and center speakers should face the seated listener and be placed at ear level. The center speaker produces a richer sound image by enhancing the perception of the sound's source and movement.

Surround: Place the left and right Surround speakers 1 meter (3 feet) above the listener's ear level and facing toward the sides of the room, making sure that the listener is within the speakers' dispersion angle. These speakers produce the feel of a moving sound while creating the sensation of being in the middle of the action.

Subwoofer: Install a subwoofer with a built-in power amplifier for powerful bass sounds. The placement of the subwoofer does not affect the final quality of the sound image too much, so you can install it with the room layout in mind.

Refer to the speaker's instruction manual for more details.

Connecting the power

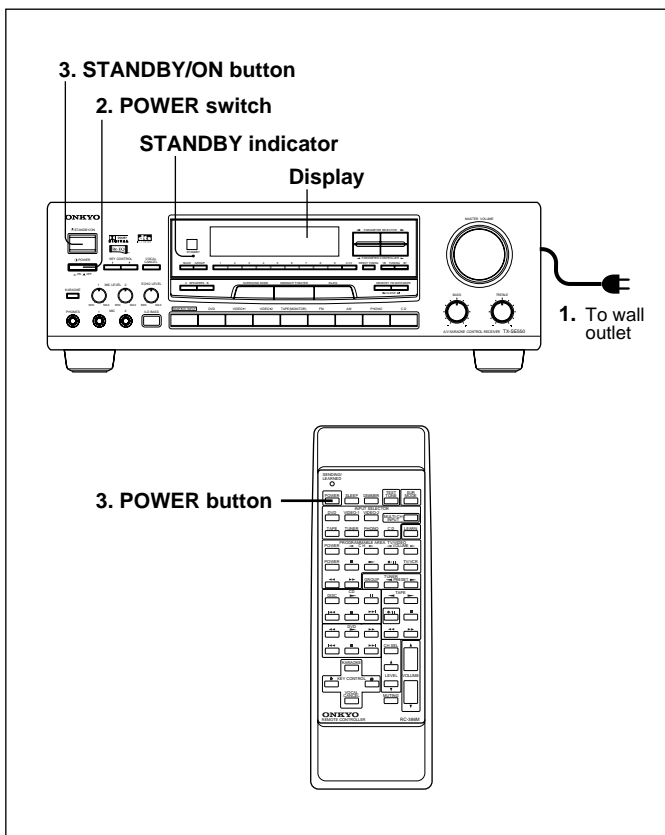

Connecting the power

- Before you plug in the receiver, confirm that all connections have been made properly.
- Turning on this receiver's power may cause a momentary power surge, which might interfere with other electrical equipment, such as computers. If this happens, use a wall outlet on a different circuit.

1. **Plug the power cord into an AC wall outlet.**
2. **Press the POWER switch to set the receiver to Standby mode.**

The STANDBY indicator will light up.

3. **Press the STANDBY/ON button or POWER button on the remote controller to turn on the receiver. The display will light up and the STANDBY indicator will be turned off.**

If you press the STANDBY/ON button or POWER button on the remote controller again, the receiver returns to Standby mode.

- You cannot use the remote controller if the POWER switch on the receiver is set to OFF.
- Set the volume level to minimum before you turn off the power to the unit.

Making antenna connections

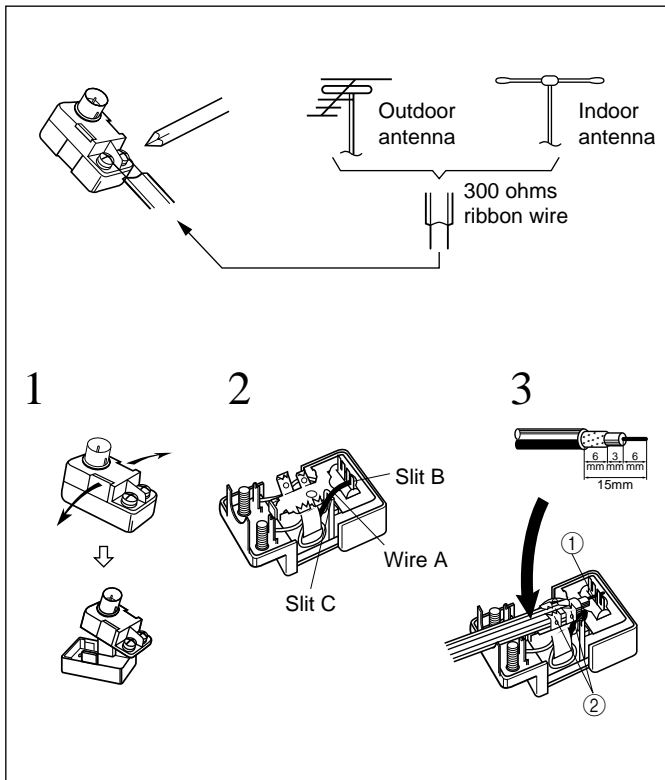

Connecting the antenna cable to the 75/300 ohm antenna adapter (Worldwide models)

Connecting the 300 ohm ribbon wire:

Loosen the screws and wrap the wire around these screws. Then tighten the screws with a screwdriver.

Connecting the coaxial cable:

1. With your fingernail or a small screwdriver, press the stoppers outward and remove the cover.
2. Remove the transformer wire A from slit B and insert it into slit C.
3. Prepare the coaxial cable as shown in the diagram. Connect the 75/300 ohm antenna adapter to the coaxial cable.
 - ① Insert the end of the cable.
 - ② Clamp it in place with pliers.
4. Re-install the cover.

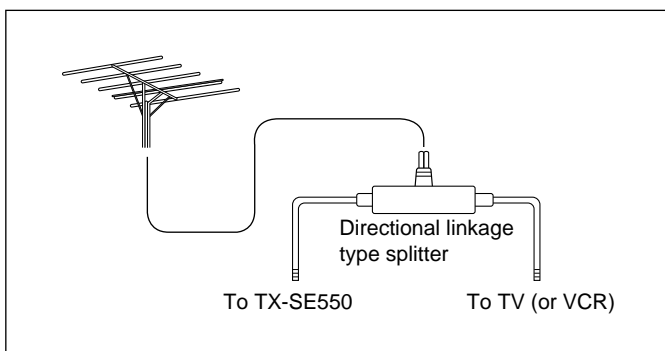

Directional linkage

Do not use the same antenna for both FM and TV (or VCR) reception since the FM and TV (or VCR) signals can interfere with each other. If you must use a common FM/TV (or VCR) antenna, use a directional linkage type splitter.

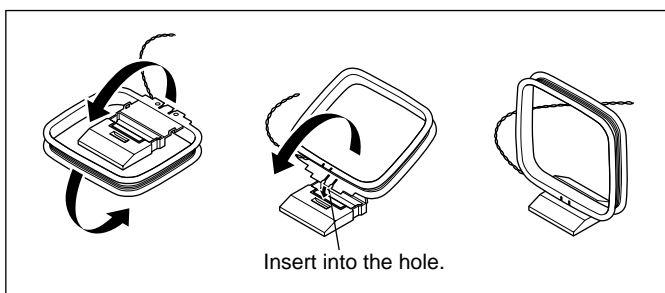

Assembling the AM loop antenna

Assemble the loop antenna as shown in the illustration.

- Refer to the next page for details on connecting the AM loop antenna.

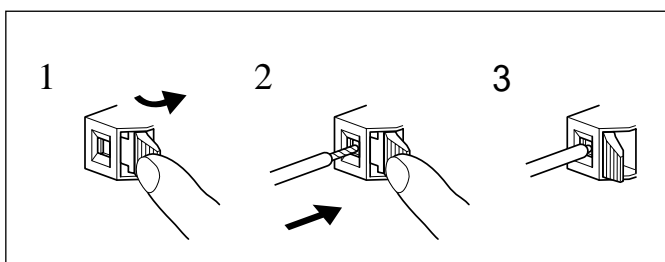

Connecting the antenna cable

1. Press down the lever.
2. Insert the wire into the hole.
3. Release the lever to replace it.

Making antenna connections

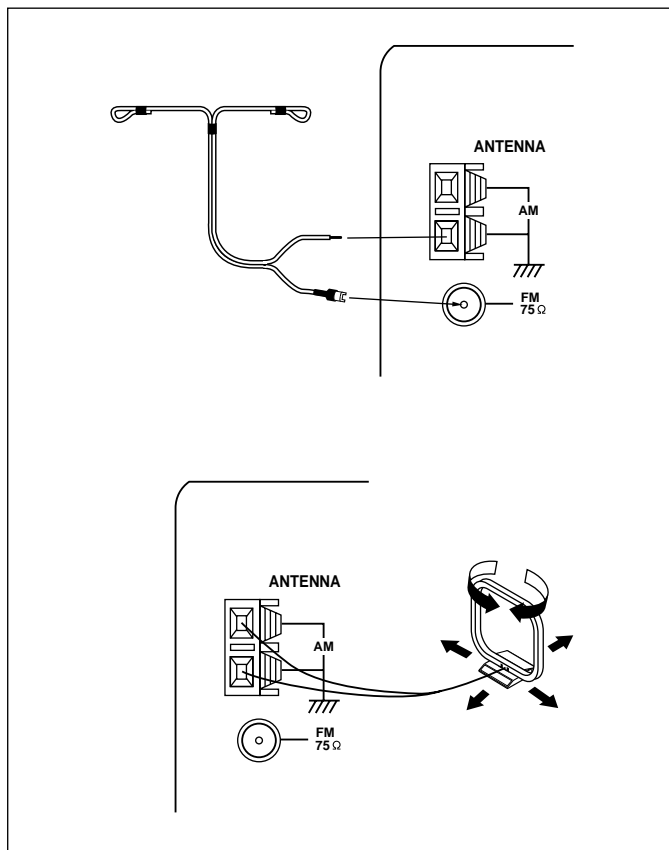

Connecting the included antennas

Connecting the T-shaped FM antenna:

The T-shaped FM antenna is for indoor use only. Extend the antenna and move it in various directions until the clearest signal is received. Fix it with push pins or similar implements in the position that will cause the least amount of distortion.

If the reception is not very clear with the attached T-shaped FM antenna, the use of an outdoor antenna is recommended.

Connecting the AM loop antenna:

The AM loop antenna is for indoor use only. Set it in the direction and position where you receive the clearest sound. Put it as far away as possible from the unit, TVs, speaker cables, and power cords.

When reception is not satisfactory with the attached AM loop antenna alone, connection of an outdoor antenna is recommended.

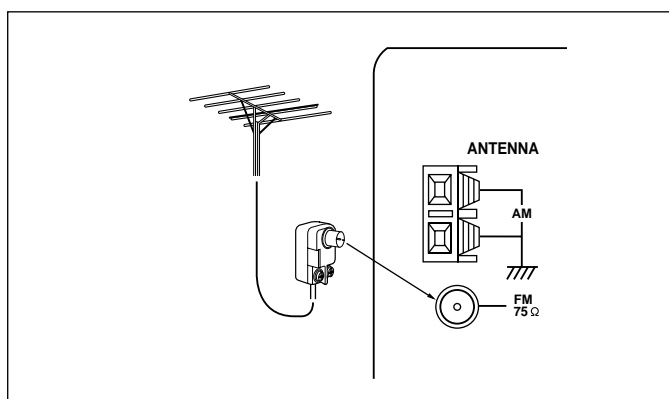

Connecting an FM outdoor antenna

Please make sure that you follow the considerations below regarding the location.

Keep the antenna away from noise sources (neon signs, busy roads, etc.).

It is dangerous to put the antenna close to power lines. Keep it well away from power lines, transformers, etc.

- To avoid the risk of lightning and electrical shock, grounding is necessary. Follow item 19 of the “Important Safeguards” on page 2 when you install the outdoor antenna.

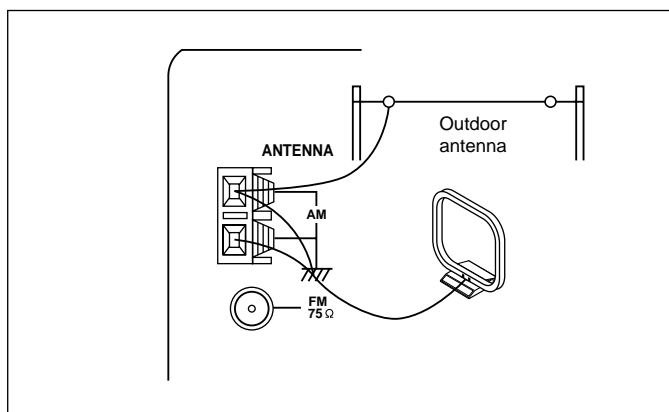

Connecting an AM outdoor antenna

The outdoor antenna will be more effective if it is stretched horizontally above a window or outside.

- Do not remove the AM loop antenna.
- To avoid the risk of lightning and electrical shock, grounding is necessary. Follow item 19 of the “Important Safeguards” on page 2 when you install the outdoor antenna.

Speaker setup

PARAMETER SELECTOR/ PARAMETER CONTROLLER buttons
Use these buttons to set the speaker parameters, such as the type and distance.

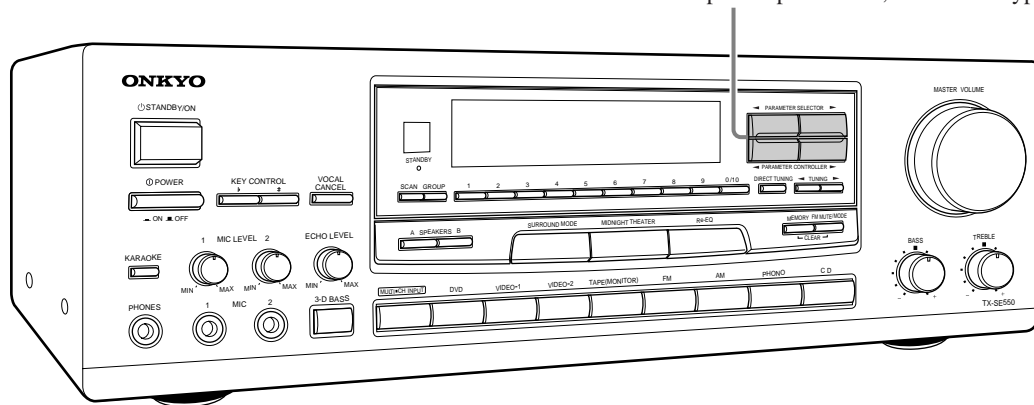

LEVEL ▲/▼ buttons

Use these buttons to adjust the level of each speaker.

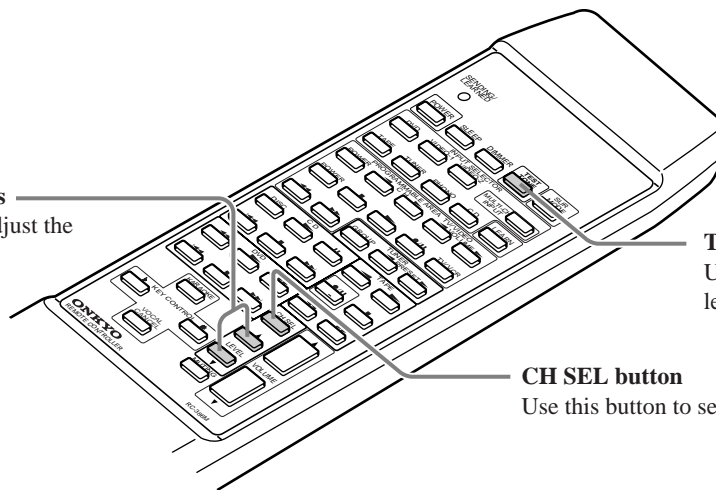

TEST TONE button

Use this button to adjust the level of each speaker.

CH SEL button

Use this button to select a speaker.

1	
2	<p>SW YES or SW NO</p>
3	<p>FRT LRG or FRT SML</p>
4	<p>CNT YES or CNT NO</p>
5	<p>SUR YES or SUR NO</p>

Speaker setup

Before operating your stereo system, you need to set the type and position of the connected speakers.

1. Press the **PARAMETER SELECTOR▶** button once to display the subwoofer parameter
2. Press the **PARAMETER CONTROLLER ◀/▶** buttons to select “YES” if a subwoofer is connected, or select “NO” if a subwoofer is not connected.
3. Press the **PARAMETER SELECTOR▶** button to display the front speaker size parameter, and press the **PARAMETER CONTROLLER ◀/▶** buttons to select “LRG” or “SML” according to the speaker size.
 LRG: Select this for large, wideband speakers.
 SML: Select this for small speakers with limited bass signal handling.
4. Press the **PARAMETER SELECTOR▶** button to display the center speaker parameter, and press the **PARAMETER CONTROLLER ◀/▶** button to select “YES” if a center speaker is connected, or select “NO” if a center speaker is not connected.
5. Press the **PARAMETER SELECTOR▶** button to display the surround speaker, and press the **PARAMETER CONTROLLER ◀/▶** button to select “YES” if surround speakers are connected, or select “NO” if surround speakers are not connected.

Speaker setup

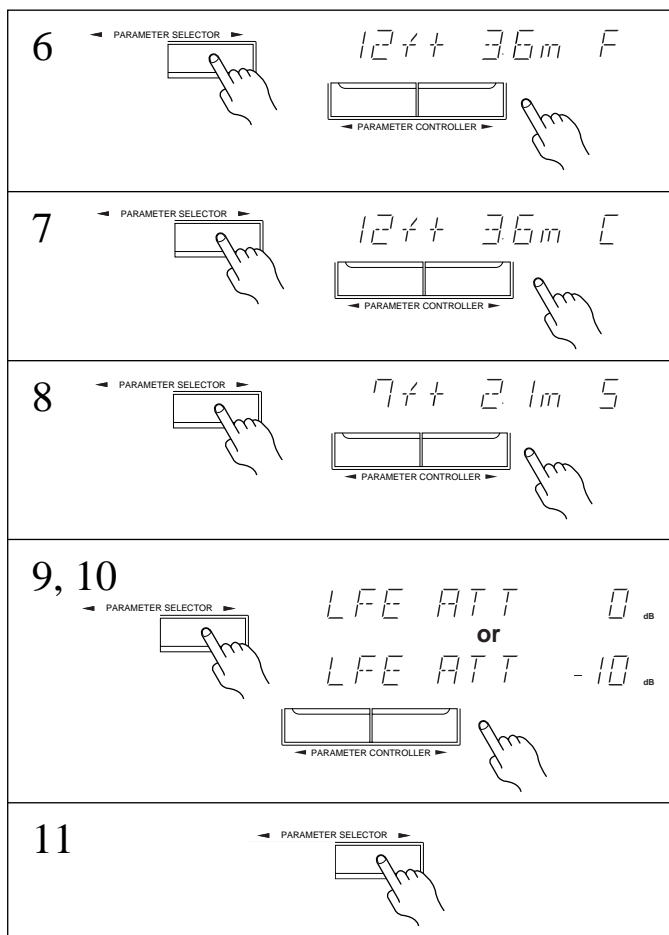

6. Press the **PARAMETER SELECTOR** button to display the **front speaker position parameter**, and press the **PARAMETER CONTROLLER** button repeatedly to set the distance value from your listening position to the front speaker. Pressing the **PARAMETER CONTROLLER** button repeatedly increases the value. Pressing the **PARAMETER CONTROLLER** button repeatedly decreases the value. Set the value closest to the actual distance.
7. Press the **PARAMETER SELECTOR** button and use the **PARAMETER CONTROLLER** buttons to set the **center speaker position parameter**. You cannot set the following values:
 - Values larger than the front speaker position setting
 - Values smaller than the value obtained by subtracting "5ft" from the front speaker setting
8. Press the **PARAMETER SELECTOR** button and use the **PARAMETER CONTROLLER** buttons to set the **surround speaker position parameter**. You cannot set the following values:
 - Values larger than the front speaker position setting
 - Values smaller than the value obtained by subtracting "15ft" from the front speaker setting
9. Press the **PARAMETER SELECTOR** button to display the **LFE LEVEL ATT** parameter.
10. Press the **PARAMETER CONTROLLER** buttons to select **0** or **-10dB**. In general, leave this parameter set to 0dB. When Dolby digital sound is played and if the bass range is too loud, set this parameter to "-10dB" to decrease the Low Frequency Effect in the low frequency channel by 10dB.
11. Press the **PARAMETER SELECTOR** button to return to the original display.

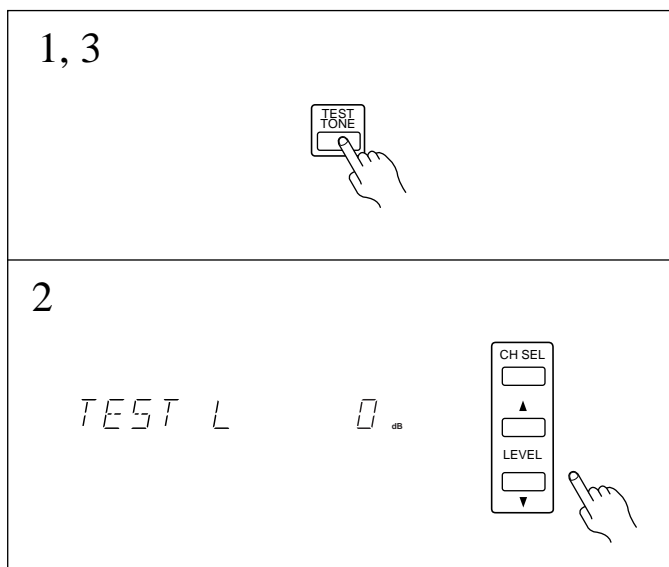

Test Tone (Remote controller only)

Use the remote controller and produce the test tone to adjust the level of the connected speakers.

1. Press the **TEST TONE** button. Each speaker produces the test tone (pink noise) in the following order:
 - ▶ L (Front L ch) → C (Center ch) → R (Front R ch)
 - ◀ SW (Subwoofer) ← LS (L-Surround) ← RS (R-Surround) ◀
2. To adjust the level of each speaker, press the **CH SEL** button to select a speaker and press the **LEVEL** buttons to raise or lower the level. The test tone should sound at the same level when you hear it in your listening position. You can adjust the level in the range between -12dB and +12dB. If you adjust the level to +1dB or higher, the overall volume level will not reach the maximum level when you set the **MASTER VOLUME** control to its maximum. Refer to the Note on page 16 for more information.
3. Press the **TEST TONE** button to complete adjustment.

Parameter selector

This chart shows how the display changes when the **PARAMETER SELECTOR** buttons are pressed. Selecting a parameter and pressing the **PARAMETER CONTROLLER** button will change the value or setting for the selected parameter.

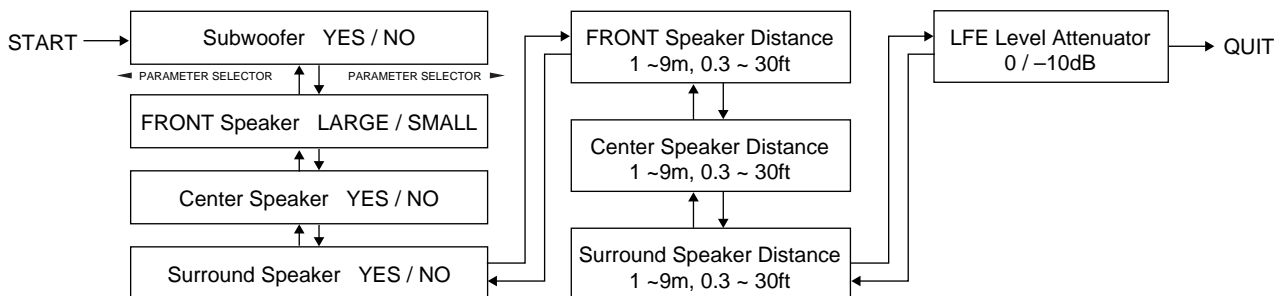

Selecting a sound source

Follow the steps below to select a device to play the sound source.

- 2. Make sure that the SPEAKERS A indicator is lit on the display. If it is not lit, press the SPEAKERS A button.**
(Refer to the "Speakers selector" section on the page 18 for more details.)

- 4. Adjust the volume to an appropriate level.**
These controls allow you to adjust the volume of the Front, Center, Surround speakers and subwoofer simultaneously. Turning the control clockwise increases the volume level. Turning the control counter-clockwise decreases the volume level.

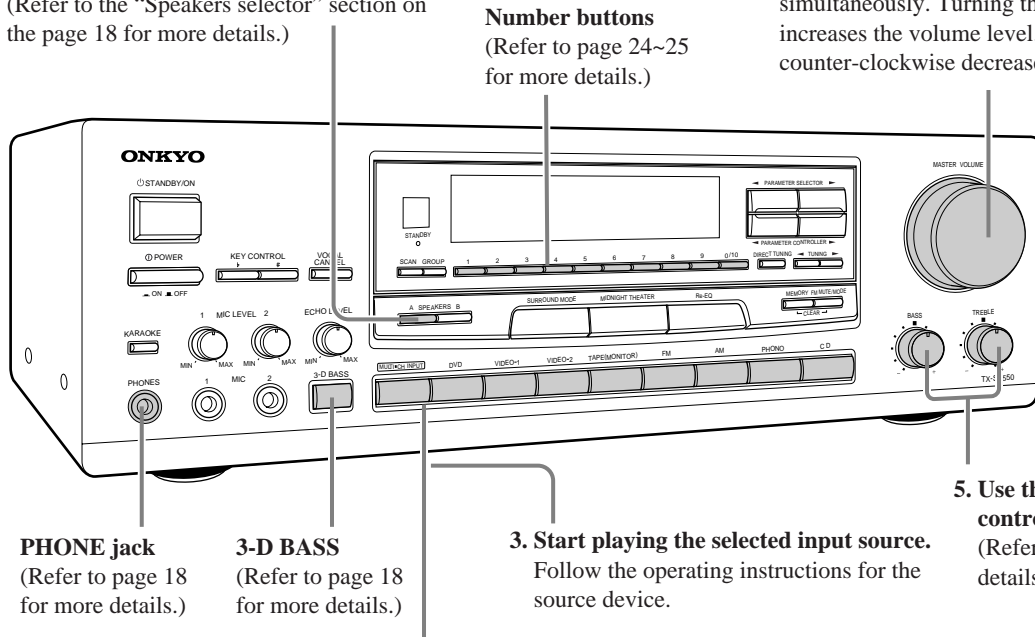

- 1. Press the desired input selector button or MULTI-CH INPUT button.**
The selected source name appears on the display. Refer to page 17 for more information on MULTI CH INPUT.

- 3. Start playing the selected input source.**
Follow the operating instructions for the source device.

- 5. Use the bass, treble controls to adjust the tone.**
(Refer to page 18 for more details.)

- 1. INPUT SELECTOR button**
Use this button to select a desired sound source.

- SLEEP button**
This button allows you to set the sleep timer.
(Refer to page 19 for more details.)

- LEVEL ▲/▼ button**

- DIMMER button**
Use this button to change the brightness of the display (normal or dim).

- MUTING button**
This button mutes the sound temporarily.
(Refer to page 19 for more details.)

- MULTI-CH INPUT button**

- CH SEL button**

- 4. VOLUME button (▲ up/▼ down)**
Use this button to adjust the volume level.

Note:

If you hear no sound from the speakers, check the following items:

- Make sure that all devices and speakers are connected correctly and securely.
- Make sure that the TAPE MONITOR indicator is not lit on the display when you select an input source other than TAPE. If the indicator is lit, no sound will be produced. Press the TAPE (MONITOR) button to turn it off and press the desired input selector button.
- The sound is muted when the MUTING indicator is lit. Press the MUTING button on the remote controller to cancel the mute function.
- Refer to page 26 for more information on how to use TAPE MONITOR for recording.
- When you select a source that is connected to the DIGITAL INPUT jacks on the rear panel, you must select digital input (refer to page 17.).
- If you have selected MULTI CH INPUT, you need to adjust the level of each speaker (refer to page 17).
- You can use the MASTER VOLUME control to adjust the overall speaker level in the range of $-\infty$ to -61 to $+18$ dB. The level value will appear on the display. However, if you have set the level of any individual speaker to $+1$ dB or higher, setting the MASTER VOLUME control to its maximum will not raise the overall volume level to $+18$ dB (maximum). Refer to the following sections for more information on adjusting the speaker level:
"Test Tone (Remote control only)" on page 15.
"When Multi channel input is selected as a source" on page 17.

Selecting a sound source

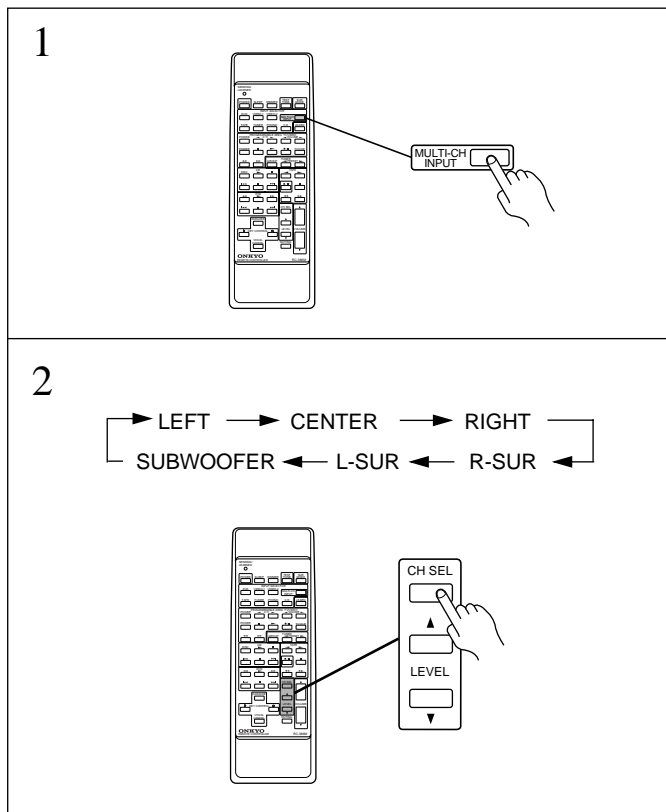

When Multi channel input is selected as a source

Follow the steps below to adjust the level of each speaker if you have selected MULTI-CH INPUT.

1. Press **MULTI-CH INPUT** button on the remote controller.
You cannot select any Surround mode.
2. Press the **CH SEL** button to select the desired speakers.
3. Use the **LEVEL ▲/▼** button to change the volume level of the speakers.

You can adjust the volume level of each speaker individually. Adjust the level while listening to the sound in the listening position.

You can adjust the level of the front, center, and surround speakers in the range between -12dB and $+12\text{dB}$.

You can adjust the subwoofer level in the range between -30dB and $+12\text{dB}$.

If you adjust the level to $+1\text{dB}$ or higher, the overall volume level will not reach the maximum level when you set the **MAS-TER VOLUME** control to its maximum. Refer to the Note on page 16 for more information.

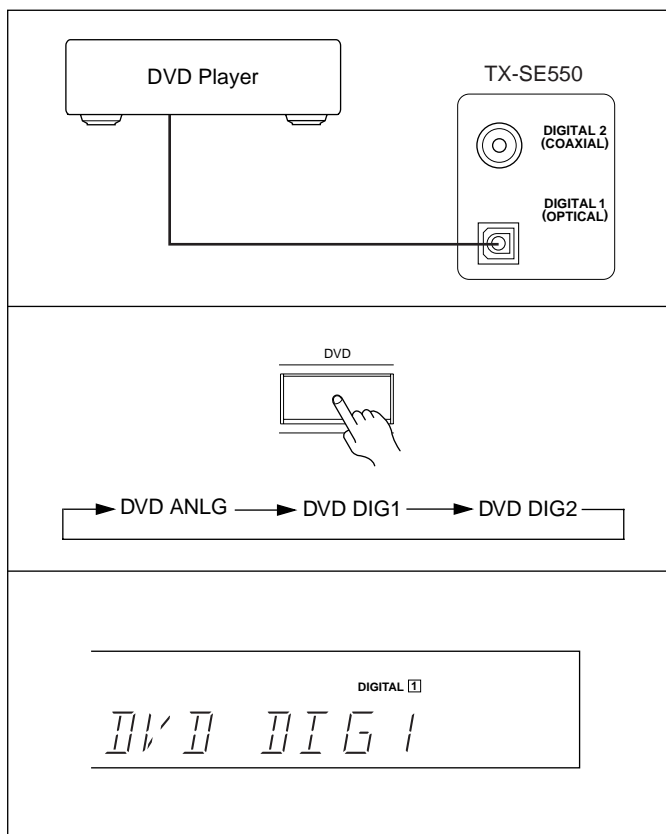

Switching between digital and analog inputs

Either a digital or analog device can be connected to the digital connector. Follow the steps below to select digital or analog according to the type of the connected device.

Assume that you have connected a DVD player to the DIGITAL 1 connector.

Press the Input Selector button (DVD) repeatedly to select "DVD DIG1."

Pressing the DVD button repeatedly changes the display as shown in the illustration on the left.

ANLG : Analog input

DIG1 : Digital input (DIGITAL 1 (OPTICAL))

DIG2 : Digital input (DIGITAL 2 (COAXIAL))

If an analog device is connected, press the Input Selector button to select "ANLG."

You can switch between digital and analog for the DVD, VIDEO-1, 2, and CD input sources.

To cancel a digital input assignment, press the corresponding input selector button until "ANLG" is displayed.

Even when the digital inputs are used, the analog connecting cables must be left in place. Otherwise, the audio output from TAPE OUT and VIDEO-2 will not work. (See page 7.)

Warning:

- Do not play CD-ROM discs that contain computer data as they may damage the speakers when the sound is amplified by the receiver.

Selecting a sound source

Speakers selector (SPEAKERS A, B)

SPEAKERS A: This button turns on or off the speakers connected to the FRONT SPEAKERS A, CENTER SPEAKER, SURROUND SPEAKERS and SUBWOOFER terminals.

When you select Dolby Pro Logic, Hall, Live, or Multi-CH INPUT, be sure to turn on SPEAKERS A.

When the speakers are turned on, the SPEAKERS A indicator lights up.

SPEAKERS B: This button turns on or off the speakers connected to the FRONT SPEAKERS B terminals.

When the speakers are turned on, the SPEAKERS B indicator lights up.

Note:

You cannot use the A and B speakers simultaneously.

Adjusting the tone (BASS, TREBLE, 3-D BASS)

Treble and bass adjustment is effective only for the Front speakers and headphones.

BASS: Boosts or cuts the bass response.

TREBLE: Boosts or cuts the treble response.

3-D BASS: This button is used to clearly reproduce ultra low frequencies. When this button is pressed, the 3-DB indicator lights up. 3-D BASS can be used in all surround modes.

- The 3-D BASS control affects only the left/right Front and Center speakers. The BASS and TREBLE controls affect only the left/right Front speakers.

Listening through headphones (PHONES)

You can connect stereo headphones to the PHONES jack using a standard stereo plug.

If you connect headphones, the unit will enter STEREO mode automatically, and no sound will be produced from the speakers. If you have selected MULTI-CH INPUT, you will hear sound only from the FRONT L and R channels.

Selecting a sound source

Sleep function (Remote controller only)

The sleep timer can turn off the power to the system after a specified time period.

To set up this function, use the remote controller supplied with this receiver.

1. **Start playing the source you would like to listen to (CD, tape, or radio broadcast).**
2. **Press the SLEEP button repeatedly to set the duration of time after which you want the system to turn off.**

The longest timer value you can set is 90 minutes. Pressing the SLEEP button each time reduces the time value in 10-minute increments.

When the specified time comes, the power will be switched off automatically.

Disabling the Sleep function

Press the SLEEP button until it returns to the selected input source name.

or

The timer setting will be cancelled if you turn off the power to the unit.

Temporary muting (MUTING) (Remote controller only)

Press the MUTING button on the remote controller. The MUTING indicator will light and the sound from the speakers or headphones will be switched off by the receiver's audio muting circuits.

To cancel,

- press the MUTING button again, *or*
- turn the power off, then turn it on again.

To enjoy Surround mode or Stereo mode

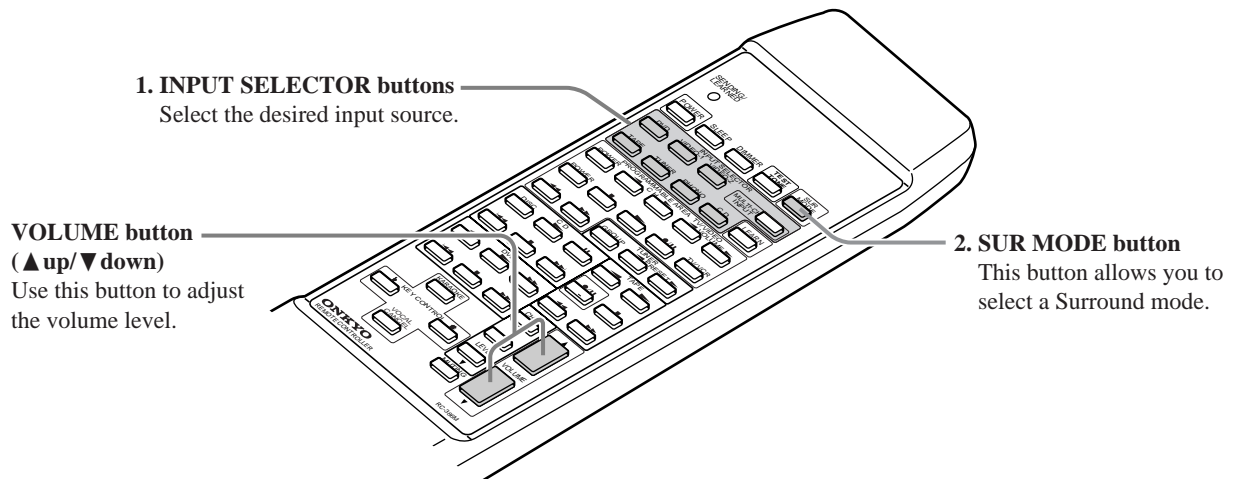
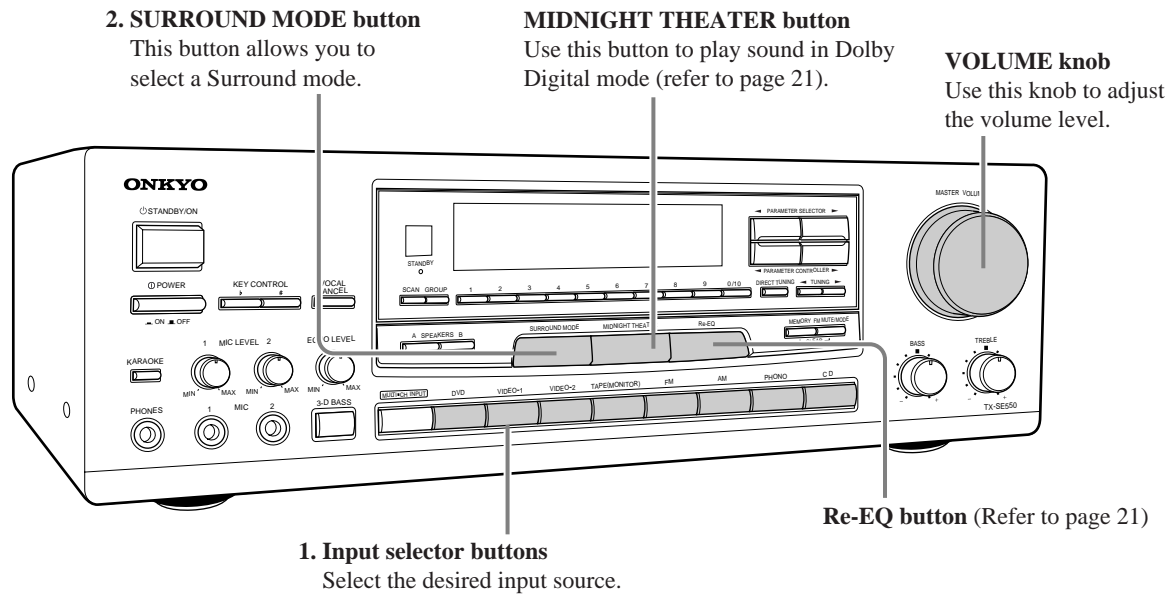

This receiver has five Surround modes. Select a suitable mode according to the type of music you are listening to, the media used, and your personal preference. The selected surround mode is automatically stored along with the selected source. Next time you select the same source again, the stored surround mode will be automatically recalled.

Surround Modes

Before using a Surround mode, make sure the Speaker Setup parameters have been set (refer to page 14). Once the parameters have been set, it is not necessary to set them again.

DOLBY DIGITAL

Dolby Digital Surround mode is used to decode media such as DVD discs bearing the  mark and Dolby Digital broadcasts. Dolby Digital is a new-generation digital audio format for multi-channel surround audio.

Adding to the conventional five full range channels, Dolby Digital supports one LFE (Low Frequency Effects) channel, which is used solely for correcting the bass range by using an independent subwoofer. Dolby Digital is sometimes referred to as 5.1-channel format since this LFE channel is calculated as 0.1.

DOLBY PRO LOGIC

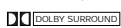
In Dolby Surround mode, video tapes and laser discs bearing the  trademark are decoded to reproduce the multi-channel Surround sound of a movie theater.

Dolby Pro Logic Surround provides four channels of surround sound (Left/Right front, Center, and monaural Surround channels), with importance placed on the Center speaker.

HALL

This mode simulates the atmosphere of a concert hall. Suitable for classical music.

LIVE

This mode reproduces the acoustics of a live performance.

ARENA Surround

This mode recreates the atmosphere of a concert in a domed stadium.

STEREO

Select this mode when you do not wish to use the surround mode. All input sound is output from the front speakers.

To enjoy Surround mode or Stereo mode

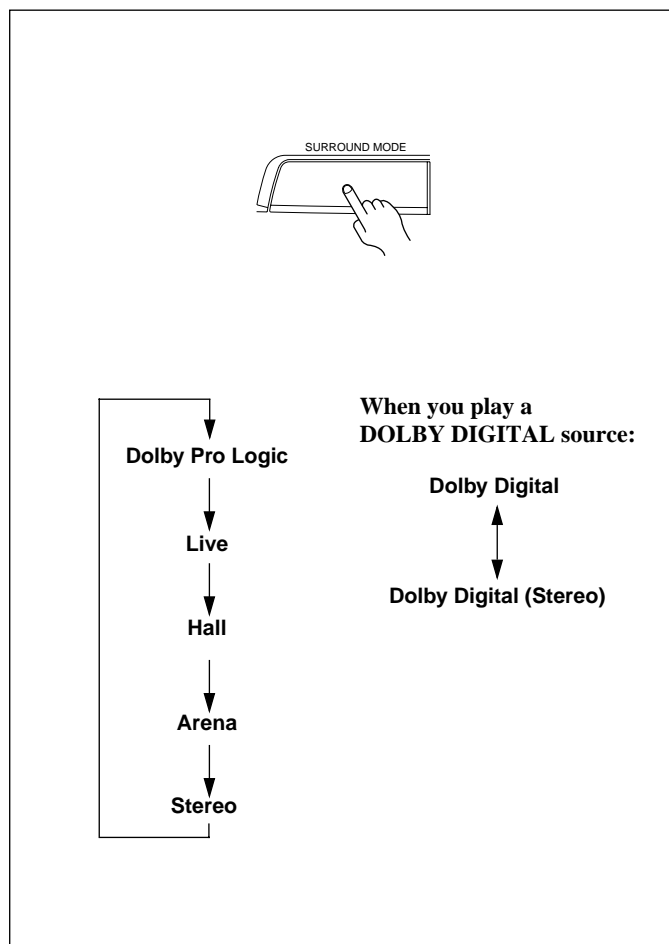

Selecting a Surround mode

1. Press an Input Selector button to select the desired sound source.

2. Press the SURROUND MODE button repeatedly until the desired Surround mode name appears.

The display changes in the order shown on left each time you press the button.

- If you are using the remote controller, press the SUR MODE button to select the desired Surround mode.
- If DOLBY PRO LOGIC is selected during playback of a DOLBY DIGITAL source, the Surround mode automatically changes to DOLBY DIGITAL and the DOLBY DIGITAL indicator lights up on the display.
- If you have set the surround speaker parameter for the speaker setup (see page 14) to "NO," STEREO or 3 STEREO will be selected for Surround mode. Only the "STEREO" setting is available if you have set both surround speaker and center speaker parameters to "NO".

3. Play the selected sound source.

Follow the steps below to adjust the speaker volume to the desired level:

1. Press the CHSEL button to select a speaker.
2. Press the LEVEL ▲/▼ buttons to adjust the level.

You can adjust the level in the range of -12dB to +12dB.

If you adjust the level to +1dB or higher, the overall volume level will not reach the maximum level when you set the MASTER VOLUME control to its maximum. Refer to the Note on page 16 for more information.

When you turn off the power, the level will be reset to the original level (the value you set using the test tone).

When you press the TEST TONE button after you set the level, the current level will be used as the value set via the test tone.

Setting the Surround mode parameters

Midnight Theater

If you play a movie at a low volume at night, set this parameter to "ON" to narrow the dynamic range of the sound to make it easier to hear.

The Midnight Theater function works only with source material that contains necessary Dolby Digital information.

Press the MIDNIGHT THEATER button during Dolby Digital playback. The MIDNIGHT THEATER indicator appears on the display. To cancel the MIDNIGHT THEATER function, press the MIDNIGHT THEATER button again.

- The Midnight Theater function is available only in Dolby Digital Surround mode.
- When you turn off the power, the MIDNIGHT THEATER function will be turned off.

Cinema Re-Equalization

Re-Equalization takes the edginess or "brightness" out of your home cinema sound, compensating for the fact that sound mixed for theaters will sound too bright when played back through speakers in the home environment.

Press the Re-EQ button, the Cinema Re-Equalizer indicator appears on the display. To cancel the Re-EQ function, press the Re-EQ button again.

- The Cinema Re-EQ function is available only in Dolby Digital and Dolby Pro Logic Surround and Multi channel input modes.

LFE (Low Frequency Effect) Level Attenuation

If the bass range is too loud, set this parameter to "-10 dB" to decrease the Low Frequency Effect in the low-frequency channel by 10 dB.

Use the Speaker Setup procedure described on page 14 to switch the LFE level between 0dB and -10dB.

- The LFE Level Attenuation function is available only in Dolby Digital Surround mode.

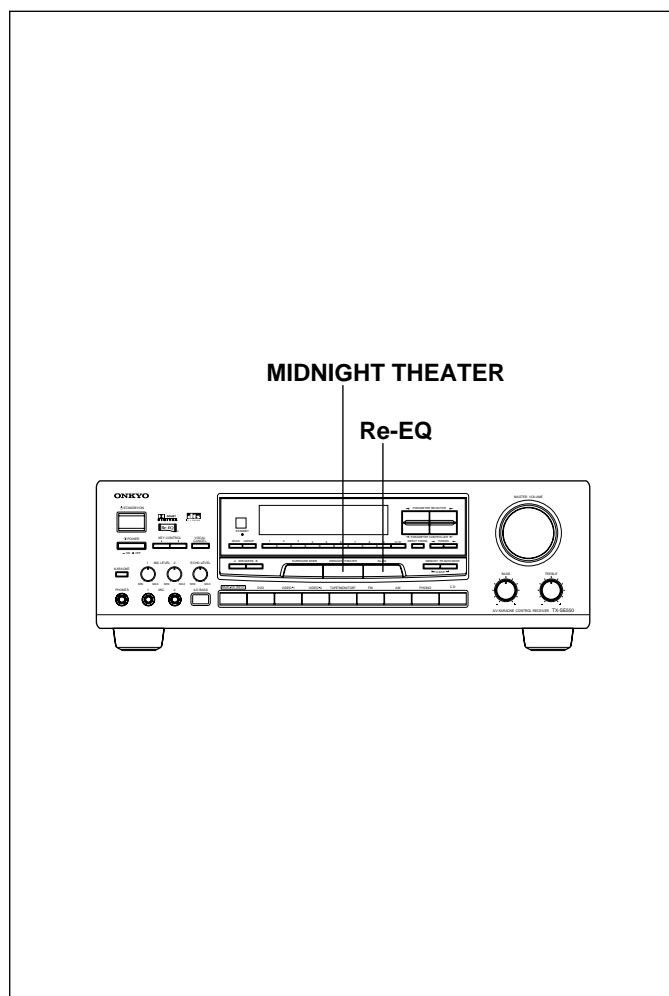

Karaoke function

5. KARAOKE button

Use this button for the Karaoke function.

6. VOCAL CANCEL button

OFF: The Vocal Cancel function is turned off and the entire sound is played.

V. CANCEL: Vocal parts are muted.

MPX L ch (Multiplex Left Channel): Used for multi-channel Karaoke software. Lch signals are output from the L/R channel.

MPX R ch (Multiplex Right Channel): Used for multi-channel Karaoke software. Rch signals are output from the L/R channel.

8. KEY CONTROL buttons

Use these buttons to adjust the pitch.

3. SPEAKERS A and SPEAKERS B buttons

7. SURROUND MODE button

4. MASTER VOLUME control

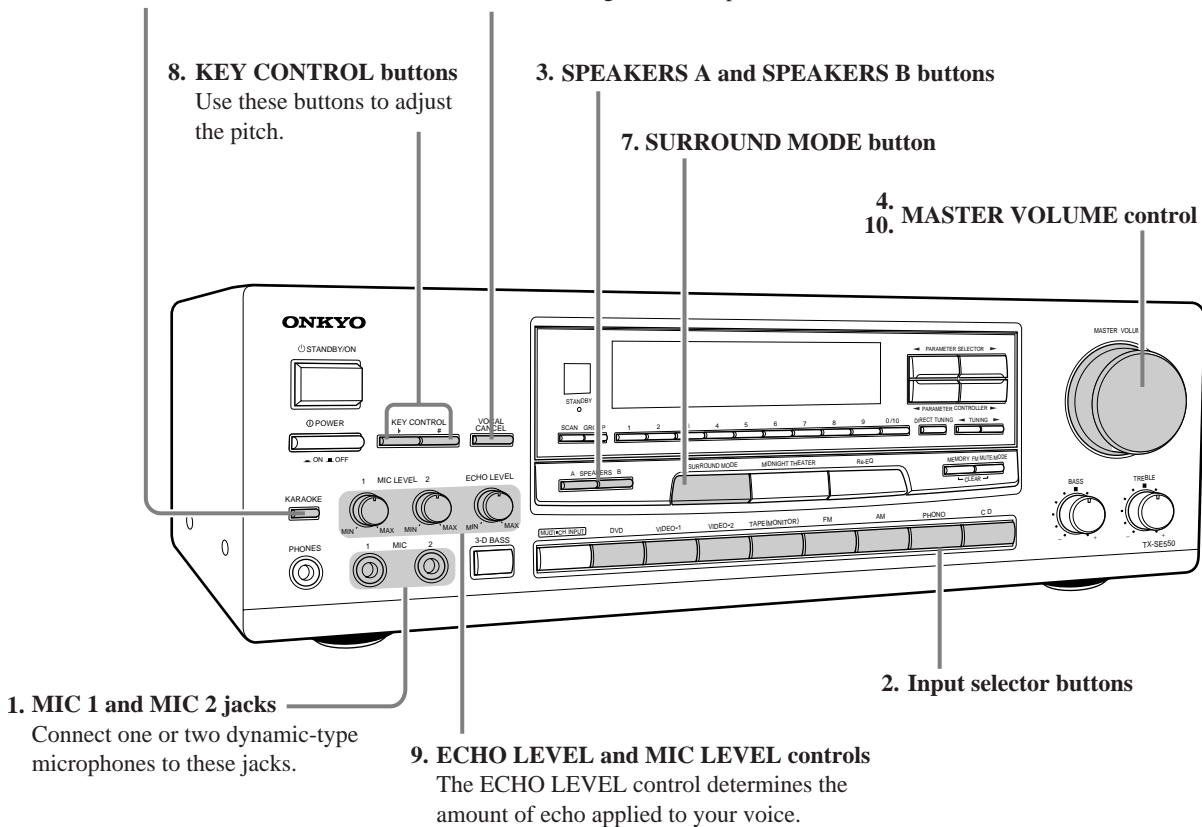

1. MIC 1 and MIC 2 jacks

Connect one or two dynamic-type microphones to these jacks.

9. ECHO LEVEL and MIC LEVEL controls

The ECHO LEVEL control determines the amount of echo applied to your voice.

5. KARAOKE button

8. KEY CON (Key Control) buttons

6. VOCAL CANCEL button

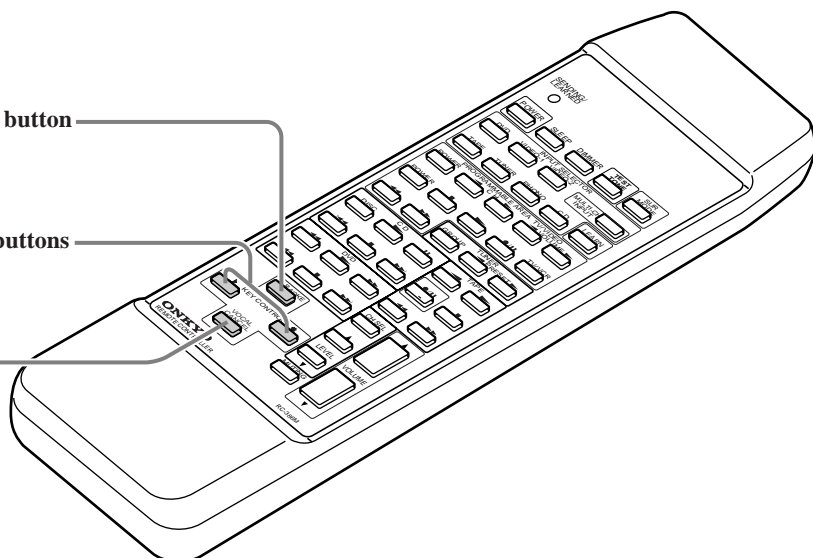

Karaoke function

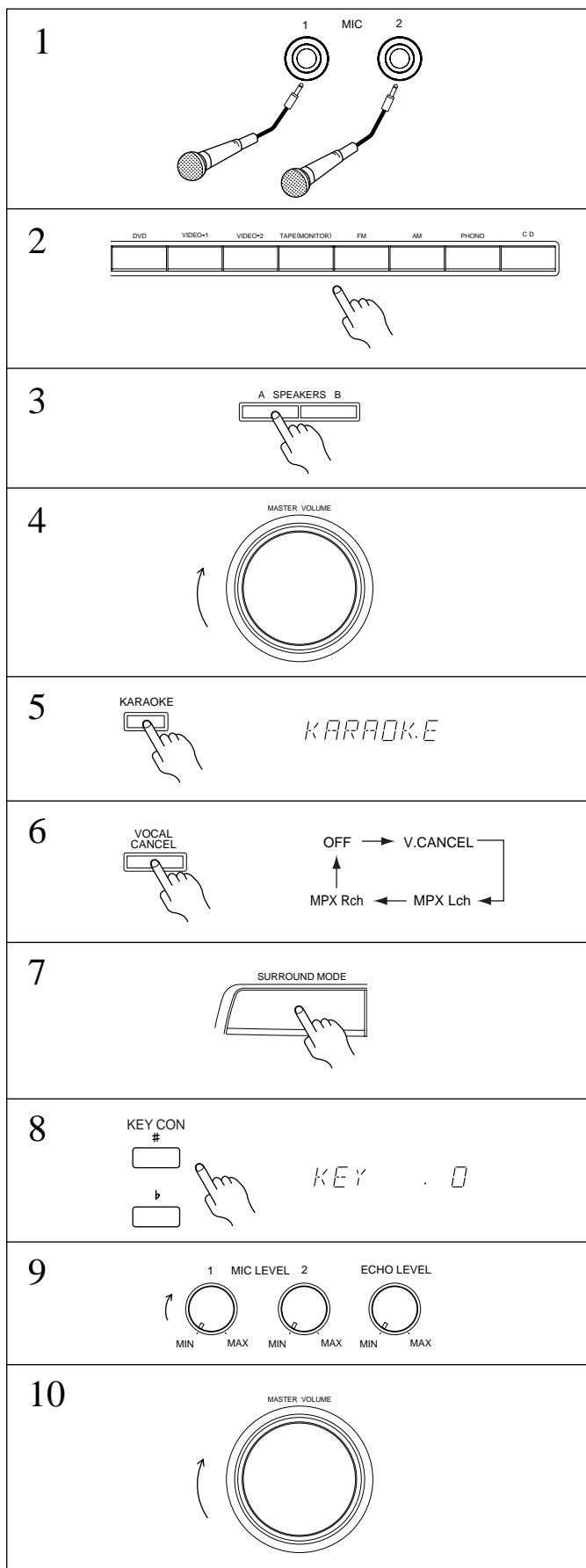

Karaoke operation

All you need to enjoy karaoke with the TX-SE550 is a dynamic microphone. The karaoke function can also cancel the vocals on your favorite songs. The amount of cancellation depends on the source material. Vocal cancellation is not possible with mono sources, and also cannot be used when the MULTI-CH INPUT button is pressed.

Before using the Karaoke function:

Turn down the MASTER VOLUME, MIC LEVEL, and ECHO LEVEL controls.

1. Connect one or two dynamic microphones to the MIC 1 and (or) MIC 2 jacks.

If you are connecting two microphones, use those with the same specifications.

2. Use the input selector buttons to select the source that you want to use for karaoke.

3. Use the SPEAKERS A and SPEAKERS B buttons to select a speaker system.

4. Set the MASTER VOLUME control to a suitable level.

5. Press the KARAOKE button.

The KARAOKE indicator lights up and "KARAOKE" appears on the display, indicating that the karaoke function is available.

6. Press the VOCAL CANCEL button to select the desired mode.

Each press of the button changes the display in the following order:

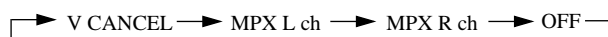

7. To add HALL surround effects, press the SURROUND MODE button. (SPEAKER A only)

You cannot use Dolby Pro Logic and Dolby Digital for the Karaoke function.

You cannot use the Karaoke function while Dolby Digital signal is being input from a digital source.

8. To adjust the pitch of the music in semitone steps (-6 ~ +6), press the KEY CONTROL button on the main unit or on the remote controller.

The **b** or **#** indicator lights up when the pitch has been changed.

If you have not used the KEY CONTROL buttons, **h** lights up.

9. Adjust the ECHO LEVEL and MIC LEVEL controls to the desired levels.

The ECHO LEVEL control determines the amount of echo applied to your voice.

10. Use the MASTER VOLUME control to adjust the overall volume level.

When you finish using the Karaoke function, or to cancel the function, press and hold down the KARAOKE button.

The KARAOKE indicator goes off. The karaoke function is canceled.

Notes:

- When using the karaoke function, keep microphones away from the speakers to prevent howling feedback.
- Disconnect the microphones or turn down the MIC LEVEL when you finish using the Karaoke function.
- Keep the karaoke volume down at night. Be considerate of your neighbors.

Tuning in a radio station

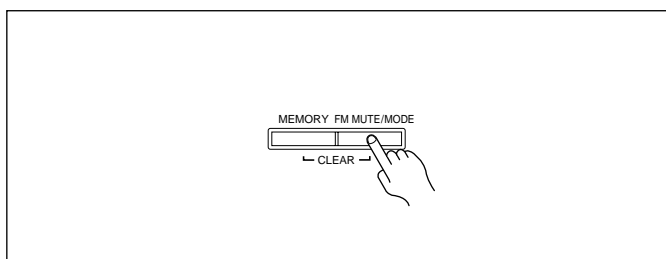
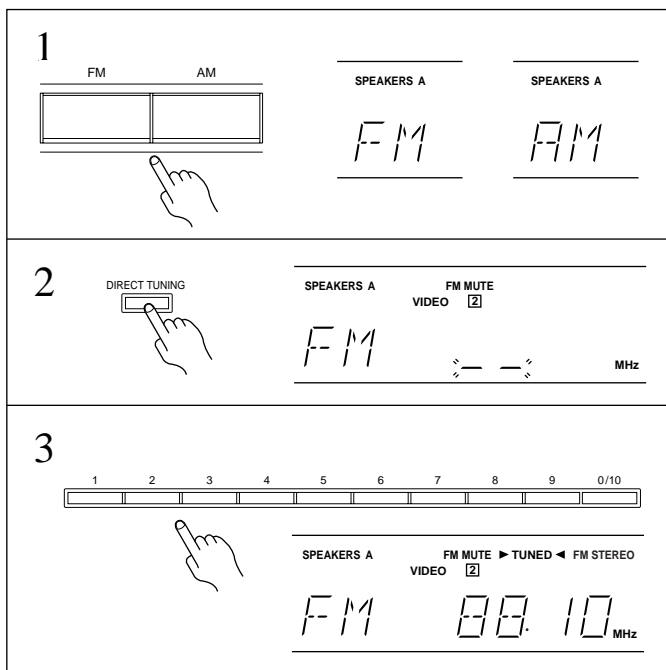
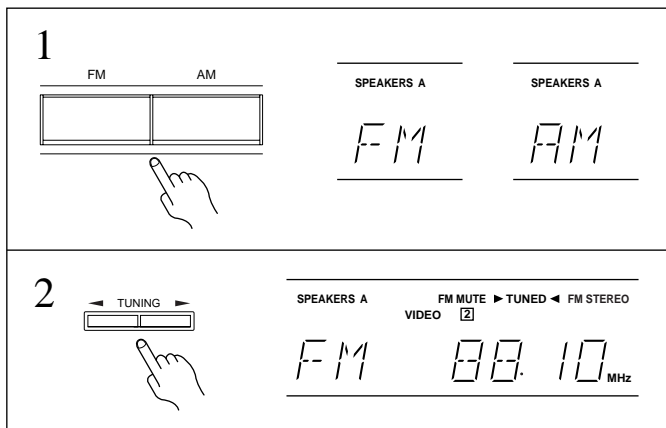
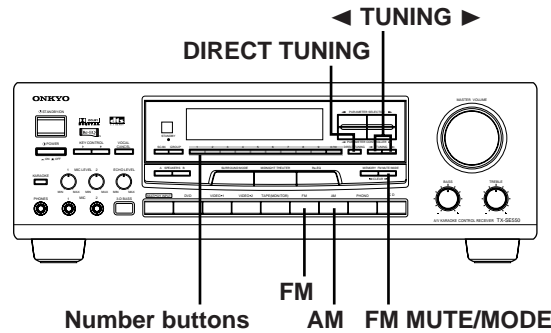

Manual tuning

1. Press the FM or AM button.
 2. Use the TUNING ◀/▶ buttons to change the frequency.
 - ▶ (up)the frequency increases.
 - ◀ (down)the frequency decreases.
- The frequency changes in 50 kHz steps in FM and 10 kHz (or 9 kHz) in AM each time you press the TUNING ◀/▶ button.
 - In FM, if this button is held continuously for more than 0.5 seconds, the frequencies are scanned automatically (FM auto tuning mode). When a broadcast is received, scanning stops.

Direct tuning

1. Press the FM or AM button.
 2. Press the DIRECT TUNING button.

The “_” will flash 16 seconds in the frequency display.
 3. Enter the frequency using the number buttons while the cursor is flashing.

Example: 88.10 MHz

 - 50 kHz step area, 8 → 8 → 1 → 0/10
 - 100 kHz step area, 8 → 8 → 1

Use the 0/10 number button to enter a 0.
- Out-of-range frequencies will be ignored.
 - When receiving AM broadcasts with a 10 kHz steps, entering a number for the 10 kHz digit will set the 1 kHz digit to 0.

Receiving RDS (European model only)

When an RDS (Radio Data System) station broadcasting PS (Program Service Name) information is received, the RDS indicator lights up and the name of the station is displayed.

- RDS reception is only available on the European model, and only in areas where RDS broadcasts are available.

Listening to a stereo radio station (FM mode)

When you tune in a stereo FM station, the FM STEREO indicator lights up if the signal is sufficiently strong. If the signal is weak, it may be impossible to tune in to the desired station. In this case, tune in as follows. Press the FM MUTE/MODE button. The FM MUTE indicator turns off. At this time, the station will be in mono and interstation noise will be heard. Select the station to which you want to listen.

Using preset radio stations

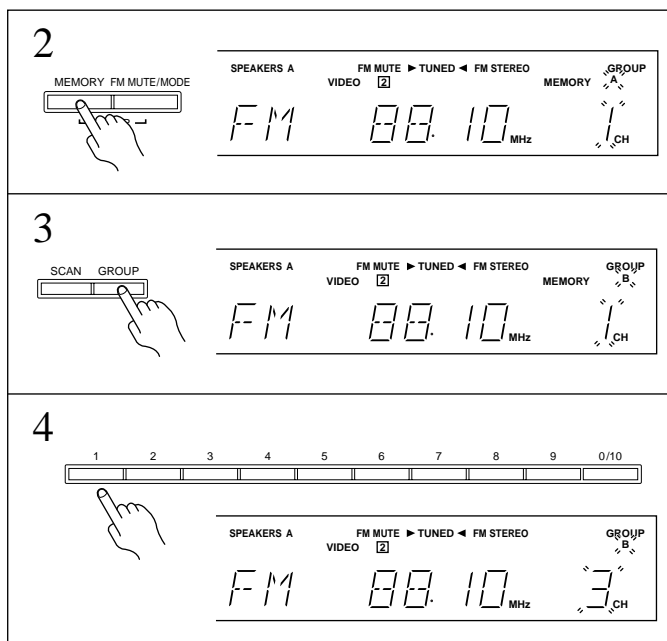
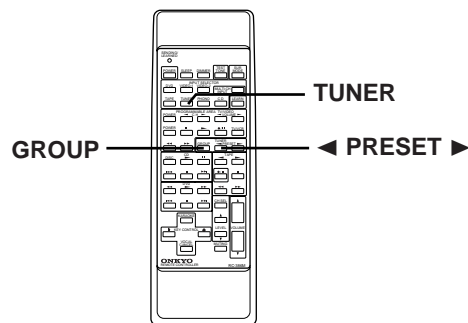
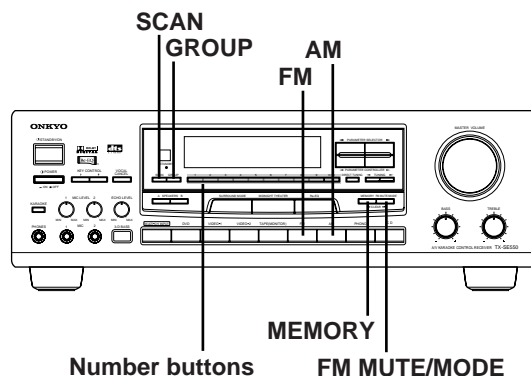

Programming radio stations

1. Select the frequency that you want to store in the memory. (See Tuning in a radio station on page 24.)
2. Press the **MEMORY** button. The MEMORY indicator will light up for eight seconds.
3. While the **MEMORY** indicator is lit, press the **GROUP** button to choose the desired group. The group shown on the display changes in the following order each time the button is pressed:
 → GROUP A → GROUP B → GROUP C →
4. Select the desired memory number using number buttons.
 - Since ten AM or FM stations can be stored in each group (A, B or C), a total of 30 stations can be stored in the memory.

Selecting a preset station

1. Select the tuner as the source by pressing the **AM** or **FM** input selector button on the main unit.
2. Press the **GROUP** button until the desired group is displayed.
3. Enter the desired preset number using the number buttons or press the **SCAN** button to scan through the preset stations. If the **SCAN** button is pressed, each station stored in the selected group will be played for five seconds. When the desired station is found, press the **SCAN** button again to stop scanning.

Remote controller operation

1. Select the tuner as the source by pressing the **TUNER** input selector button on the remote controller.
2. Press the **GROUP** button until the desired group is displayed.
3. Press the **PRESET** (◀ or ▶) button.

Cancelling preset stations

1. Select the preset station you wish to remove as explained in the previous section.
2. Press the **FM MUTE/MODE** button while holding down the **MEMORY** button. "--" appears on the channel display.
 - Once the preset station has been cancelled, the memory location can be used to store another station.

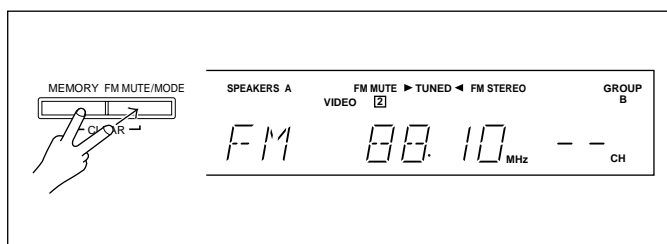
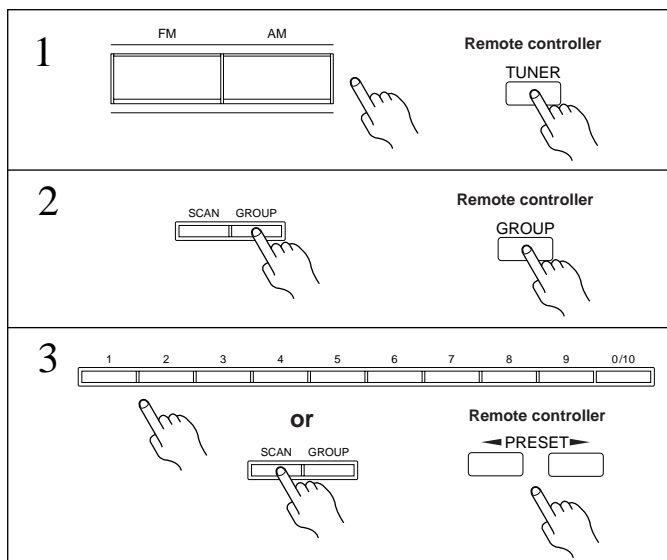

Recording a source

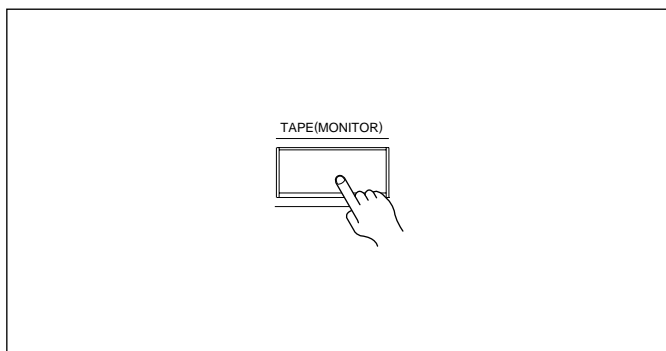
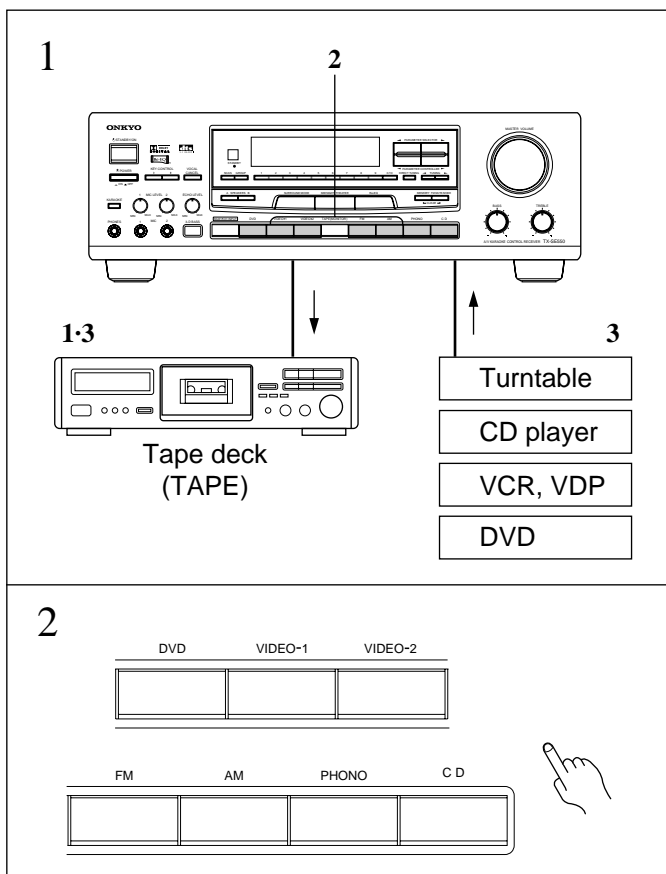

Recording an audio source

Make all connections between the tape deck and the receiver as shown in the "Audio equipment connections" diagram (page 6).

1. **Insert a blank tape into the tape deck.**
2. **Press the input selector button for the source you want to record.**
 - If you select DVD, VIDEO-1 or VIDEO-2, only the audio will be recorded.
 - If you select FM or AM, set the tuner to the station you want to record.
3. **Set the tape deck in recording mode. Start playing the source.**

Set the proper recording level using the controls on the tape deck.

 - Please read the corresponding instruction manuals for more information on how to operate the corresponding equipment.

Monitoring

If the tape deck has three heads, the signal just recorded can be monitored:

Press the TAPE (MONITOR) button. The TAPE MONITOR indicator appears on the display.

To stop monitoring, press the TAPE (MONITOR) button again. The TAPE MONITOR indicator turns off.

- You cannot use the monitor function with the MULTI-CH INPUT button turned on.
- Refer to the tape deck's instruction manual for more details.

Recording a source

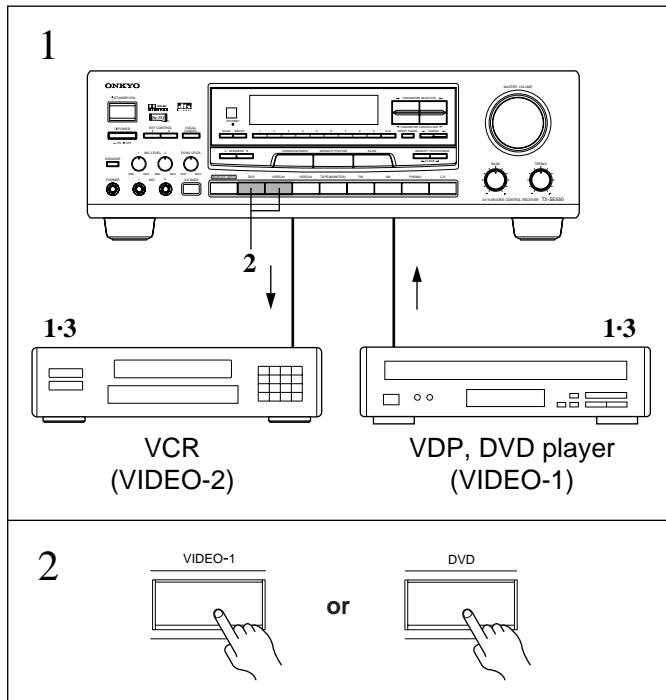

Recording data from a video disc player (or a video camcorder) to VCR

Video disc programs can be recorded onto a VCR (VIDEO-2).

1. Load a disc in the video disc player or DVD player, and insert a blank tape in the VCR (VIDEO-2).
2. Press the VIDEO-1 or DVD button.
3. Start playing the video disc player and recording on the VCR.

- Refer to the Video equipment connections section on the page 7.

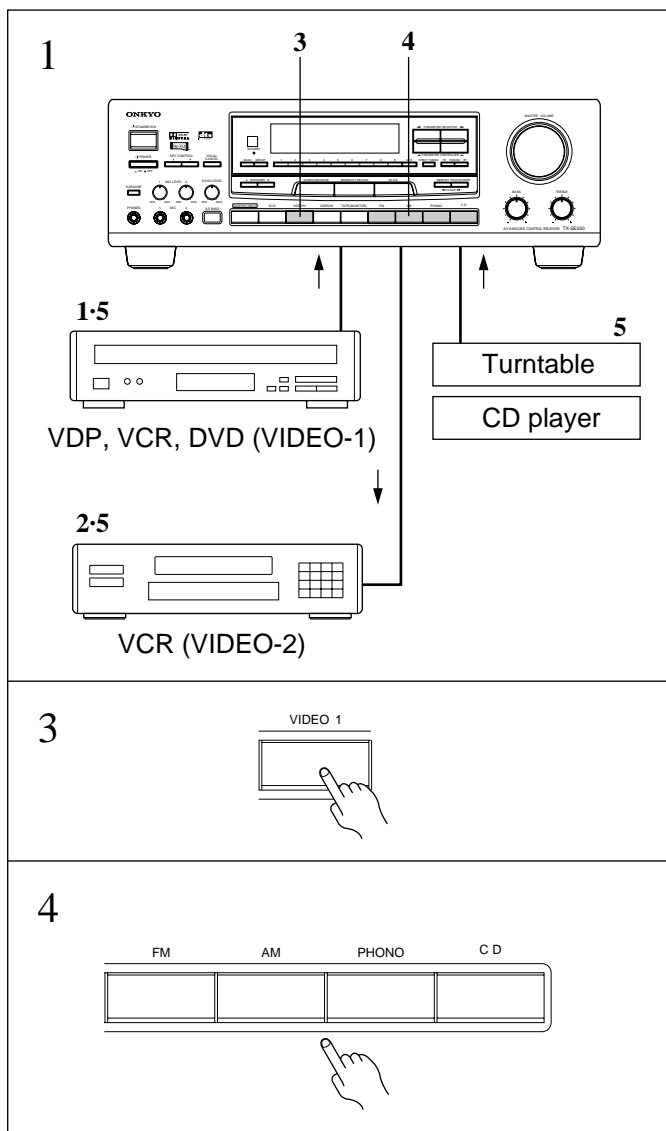

Adding new sound to a video tape during video editing

During video tape editing, you can add sound to the recording VCR from various audio program sources.

1. Insert the disc or tape that you want to record into the player connected to VIDEO-1.
2. Insert a blank video tape in the VCR connected to VIDEO-2.
3. Press the VIDEO-1 button.
4. Select the audio program source (FM, AM, PHONO, CD).
5. Start playing the video connected to the VIDEO-1 terminal and start playing the sound source. Then, start recording on the VCR that is connected to the VIDEO-2 terminal.

- Refer to the video disc player, video camcorder, DVD or VCR instruction manuals for additional information.

Programming remote controller codes

Universal Programmable Remote Controller RC-386M

If you are using another manufacturer's product that has a remote controller, you can memorize that component's codes into the RC-386M.

NOTE:

- The commands of Onkyo cassette tape decks and the CD player are already stored at the TAPE and CD positions of the remote controller.
- This remote controller uses infrared rays. Most remote controller codes can be memorized using the infrared system; however, depending on the degree to which the system differs, there may be some rare occasions when memorization is not possible.

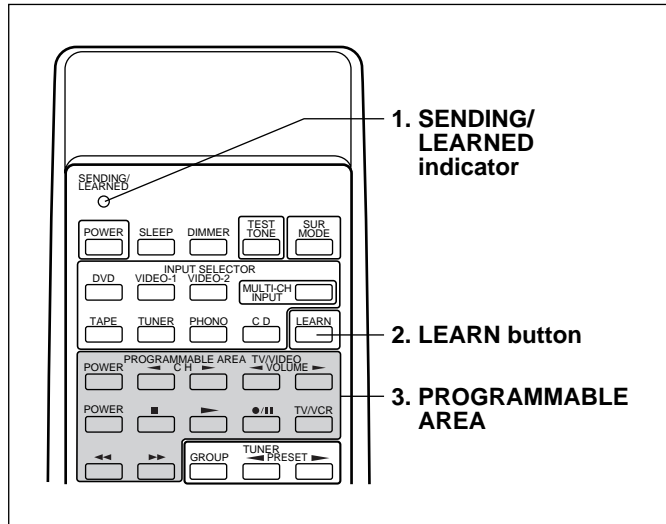

Displays and switches

- 1. SENDING/LEARNED indicator**
This indicator acts as a guide when commands are programmed into or sent by the remote controller. It also warns the user when an error is made or battery power is low.
- 2. LEARN button**
- 3. Programmable button area**
See the table below.

Symbol	Device commands		
	VDP	VCR	TV
POWER	POWER	POWER	POWER
◀ CH ▶	–	–	CHANNEL UP, DOWN
◀ VOLUME ▶	–	–	VOLUME UP/DOWN
■	STOP	STOP	–
▶	PLAY	PLAY	–
●/	–	Rec/Pause	–
TV/VCR	–	–	TV/VCR switching
◀◀	–	FAST REWIND	–
▶▶	–	FAST FORWARD	–

Programming remote controller codes

1

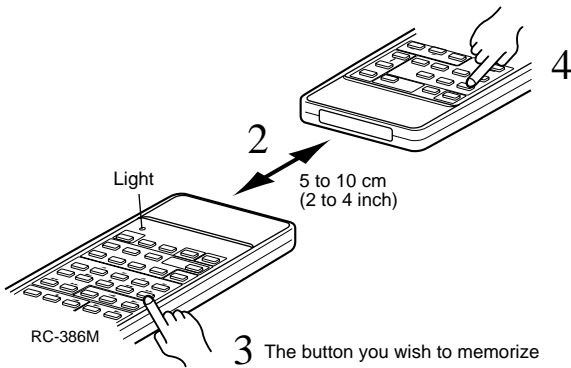
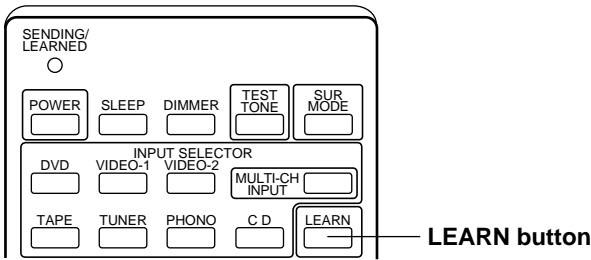

Learning new controller codes

1. Press the **LEARN** button.
2. Place the head of your old remote controller 2-4 inches (5-10 cm) from the head of the RC-386M, laying both units on a table or a flat surface.
3. On the RC-386M, press the button in the **PROGRAMMABLE AREA** into which you want to store the code.
 - The SENDING/LEARNED indicator lights up.
4. On your old remote controller, hold down the button for the function you want the RC-386M to memorize while the **LEARNED** indicator is lit. Keep pressing this button until it turns off.
 - To store a code to another button, repeat steps 1-4.

NOTES:

- Some remote controllers use a single button to perform different functions, with the function code changing each time the button is pressed. If you are using this kind of controller, please perform the "learn" operations for each function individually to store each function to a button on the RC-386M.
- For instructions regarding the operation of "learned" units, please refer to the instruction manual for each product.
- Even after codes have been memorized, please keep your old remote controller in a safe place. If the memorized codes are lost when the batteries run down, it will be necessary to memorize them once again using the old remote controller.

Reprogramming the buttons:

Follow the steps 1-4 described above. The previous codes will be lost, and new codes will be stored.

Operating the RC-386M

Please check whether previously-memorized functions are working properly. If the SENDING indicator is not illuminated when a programmed button is pressed, it may need to be relearned from your old remote controller.

Then operate the remote controller by pressing the buttons of the functions you want to use.

- If you press a button that has no code stored, the SENDING/LEARNED indicator will not light up.

Clearing all memorized codes

1. Press the **LEARN** button.
2. Press and hold the **POWER** and **VOLUME ▼** buttons together until the **SENDING/LEARNED** indicator turns off.
 - All codes stored in the programmable area will be deleted.

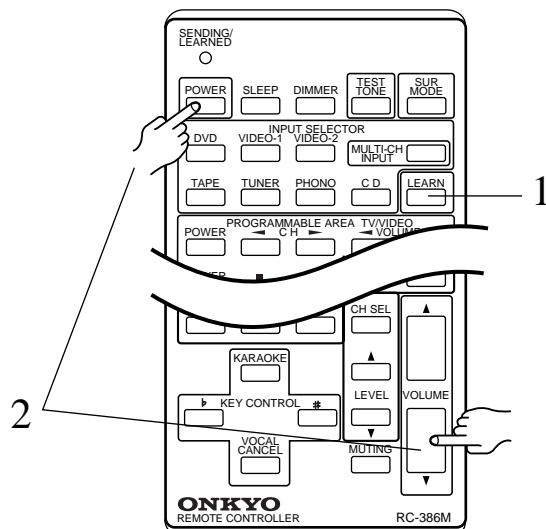

Troubleshooting guide

If a problem occurs while you are using the remote controller, first try to operate the front panel controls on the main unit to make sure that it is not due to a malfunction (or worn out batteries) in the remote controller.

Trouble	Cause	Remedy	See page
No power.	<ul style="list-style-type: none"> Power cord is disconnected. There is external noise in the computer circuits of this unit. AC fuse blown. 	<ul style="list-style-type: none"> Connect power cord. Turn the power button off and then on again or remove the AC plug from the outlet and then plug it again. Contact your Onkyo Service Center. 	11 11
Power on but no sound.	<ul style="list-style-type: none"> TAPE MONITOR indicator is lit. MUTING indicator is lit. Bad connections. Amplifier protection circuitry has been activated. ('PROTECT' will be displayed.) 	<ul style="list-style-type: none"> Press the TAPE (MONITOR) button. Press the MUTING button on the remote controller to turn it off. Check connections, speaker leads, etc. Contact your Onkyo Service Center. 	16 19 10
No sound from the center speaker, or very minimal sound.	<ul style="list-style-type: none"> Speaker cable is not corrected. SURROUND MODE button is set to STEREO. CENTER level is set to minimum. CENTER SPEAKER is set to NO. 	<ul style="list-style-type: none"> Check the connection between the amplifier and the speaker. Set the SURROUND MODE button to DOLBY PRO LOGIC, HALL, LIVE or ARENA. Set the CENTER level to the appropriate volume. Set CENTER SPEAKER to YES. 	10 21 15 14
Hum, low-frequency noise.	<ul style="list-style-type: none"> Poor or no input ground. Poor or no phono motor ground. The placement of the audio connection cables on the rear panel is incorrect. 	<ul style="list-style-type: none"> Check outer conductor of input plugs. Check for proper ground connection. Adjust the placement of the cable to reduce hum. 	6 6
Howling when the volume is turned up.	<ul style="list-style-type: none"> Turntable and speakers are too close together. 	<ul style="list-style-type: none"> Move them farther apart. 	
Rough or scratchy sound. High range is not clear.	<ul style="list-style-type: none"> Stylus of turntable pick-up is worn. Turntable stylus tip is dirty. Treble control too high. 	<ul style="list-style-type: none"> Replace. Clean. Turn treble control down. 	
AM stations cannot be received.	<ul style="list-style-type: none"> AM loop antenna is not attached. 	<ul style="list-style-type: none"> Connect the included AM loop antenna to the AM antenna terminals. 	13
Buzzing noise on AM (particularly conspicuous at night or with weak stations).	<ul style="list-style-type: none"> Noise from electrical apparatus such as fluorescent lamp. 	<ul style="list-style-type: none"> Move the AM loop antenna to different position. Set up an outdoor AM antenna. 	13 13
High-pitched noise or buzzing noise on AM.	<ul style="list-style-type: none"> Noise from TV set. 	<ul style="list-style-type: none"> Place the AM loop antenna as far as possible from the TV. Move unit away from TV set. 	13
Crackling noise on AM, FM.	<ul style="list-style-type: none"> Noise caused by turning fluorescent lamp on and off. Noise from automobile ignition. 	<ul style="list-style-type: none"> Move antenna as far as possible from the fluorescent lamp. Install an FM outdoor antenna as far as possible from the road. Change the position or direction of the outdoor antenna. 	13
TUNED and STEREO indicators light but sound is distorted and stereo separation is bad.	<ul style="list-style-type: none"> Station is too strong. Multiple reflection of the radio waves because of tall buildings or mountains. 	<ul style="list-style-type: none"> Change to T-shaped antenna. Use antenna which has better directivity and select a point where the distortion is least. 	12 13
TUNED and STEREO indicators flicker and hiss is heard on FM.	<ul style="list-style-type: none"> Station is too weak. Stereo FM broadcasts cover only about half the distance of an ordinary broadcast. 	<ul style="list-style-type: none"> Install an outdoor FM antenna. Change the position or direction of the outdoor antenna. 	13
No station is recalled when a SCAN button is pressed.	<ul style="list-style-type: none"> The power cord has been unplugged or the POWER switch has been turned off for a long time. 	<ul style="list-style-type: none"> The memory contents are lost. Store all stations again. 	25
Front panel controls function but remote controller does not.	<ul style="list-style-type: none"> No batteries in remote controller. Batteries have worn out. 	<ul style="list-style-type: none"> Insert batteries. Replace batteries. 	5 5
The sound of the playback source is not heard.	<ul style="list-style-type: none"> The input selector is not set properly. 	<ul style="list-style-type: none"> Set it to the playback source. 	16
Your voice is not heard when you speak or sing into the microphone.	<ul style="list-style-type: none"> Microphone plug is not firmly inserted into the MIC jack. Microphone is turned off. The karaoke function is turned off. 	<ul style="list-style-type: none"> Insert the plug firmly. Turn on the microphone. Press the KARAOKE button to turn on the KARAOKE indicator. 	22 22 22
Karaoke is not turned on.	<ul style="list-style-type: none"> DOLBY PRO LOGIC is selected. MULTI-CH INPUT is selected. 	<ul style="list-style-type: none"> Select another Surround mode. Select another INPUT. 	
You cannot select DOLBY PRO LOGIC.	<ul style="list-style-type: none"> KARAOKE is turned on. 	<ul style="list-style-type: none"> Turn KARAOKE off. 	22

Also refer to the respective instruction manuals of the video disc player, video cassette recorder, TV monitor, etc., that compose your entertainment system.

Specifications

AMPLIFIER SECTION

Maximum Power output (EIAJ)	100 watts × 5 at 6 ohms
Total Harmonic Distortion:	0.08% at rated power (Front)
IM Distortion:	0.08% at rated power (Front)
Damping Factor:	60 at 8 ohms (Front)
Input Sensitivity and Impedance	
PHONO:	2.5 mV, 50 kohms
LINE (CD, TAPE, DVD, VIDEO-1, 2):	200 mV, 50 kohms
MULTICHANNEL INPUT (FRONT L/R, SURROUND L/R, CENTER):	200 mV, 50 kohms
(SUBWOOFER):	36 mV, 50 kohms
DIGITAL-2 (COAXIAL):	0.5 Vp-p, 75 ohms
VIDEO IN (DVD, VIDEO-1, 2):	1 Vp-p, 75 ohms
Output Level and Impedance	
Rec out (TAPE, VIDEO-2):	200 mV, 2.2 kohms
Pre out (SUBWOOFER):	1 V, 2.2 kohms
VIDEO OUT (VIDEO-2, MONITOR):	1 Vp-p, 75 ohms
Phono Overload:	110 mV RMS at 1 kHz, 0.5% T.H.D.
Frequency Response:	20 Hz to 30 kHz, ±1 dB
RIAA Deviation:	20 Hz to 20 kHz, ±0.8 dB
Tone Control	
Bass:	±10 dB at 100 Hz
Treble:	±10 dB at 10 kHz
Signal-to-Noise Ratio	
Phono:	80 dB (IHF A, 5 mV input)
CD/Tape:	100 dB (IHF A)

VIDEO SECTION

Signal sensitivity and impedance:	1 Vp-p, 75 ohms (DVD, VIDEO-1, VIDEO-2 input, output)
-----------------------------------	---

TUNER SECTION

FM

Tuning Range:	87.5 — 108.0 MHz
Usable Sensitivity	
Mono:	11.2 dBf, 1.0 μV (75 ohms)
Stereo:	18.2 dBf, 2.2 μV (75 ohms)
50 dB Quieting Sensitivity	
Mono:	18.2 dBf, 2.2 μV (75 ohms)
Stereo:	39.2 dBf, 24 μV (75 ohms)
Capture Ratio:	1.5 dB
Image Rejection Ratio	
U.S.A. & Canadian models:	40 dB
Other area models:	85 dB

IF Rejection Ratio:	90 dB
Signal-to-Noise Ratio	
Mono:	73 dB
Stereo:	67 dB
Alternate Channel Attenuation:	55 dB
Selectivity:	50 dB (DIN)
AM Suppression Ratio:	50 dB
Total Harmonic Distortion	
Mono:	0.15%
Stereo:	0.25%
Frequency Response:	30 Hz — 15 kHz, ±1.5 dB
Stereo Separation:	45 dB at 1 kHz 30 dB at 100 Hz — 10 kHz

AM

Tuning Range	
U.S.A. & Canadian models:	530—1,710 kHz (10 kHz steps)
European & Australian models:	522—1,611 kHz (9 kHz steps)
Worldwide models:	531—1,602 kHz (9 kHz steps), 530—1,710 kHz (10 kHz steps)
Usable Sensitivity:	30 μV
Image Rejection Ratio:	40 dB
IF Rejection Ratio:	40 dB
Signal-to-Noise Ratio:	40 dB
Total Harmonic Distortion:	0.7%

GENERAL

Power Supply:	AC 230 V, 50 Hz AC 220-230 V and 120 V switchable, 50/60 Hz
Power Consumption:	3.3 A 240 W
Dimensions (W × H × D):	435 × 150 × 334 mm
Weight:	10.7 kg, 23.6 lbs.

REMOTE CONTROL

Transmitter:	Infrared
Signal range:	Approx. 5 meters, 16 ft.
Power supply:	Two "AA" batteries (1.5 V × 2)

Specifications and features are subject to change without notice.

Power supply and voltage vary depending on the area in which the unit is purchased.

Control positions and names

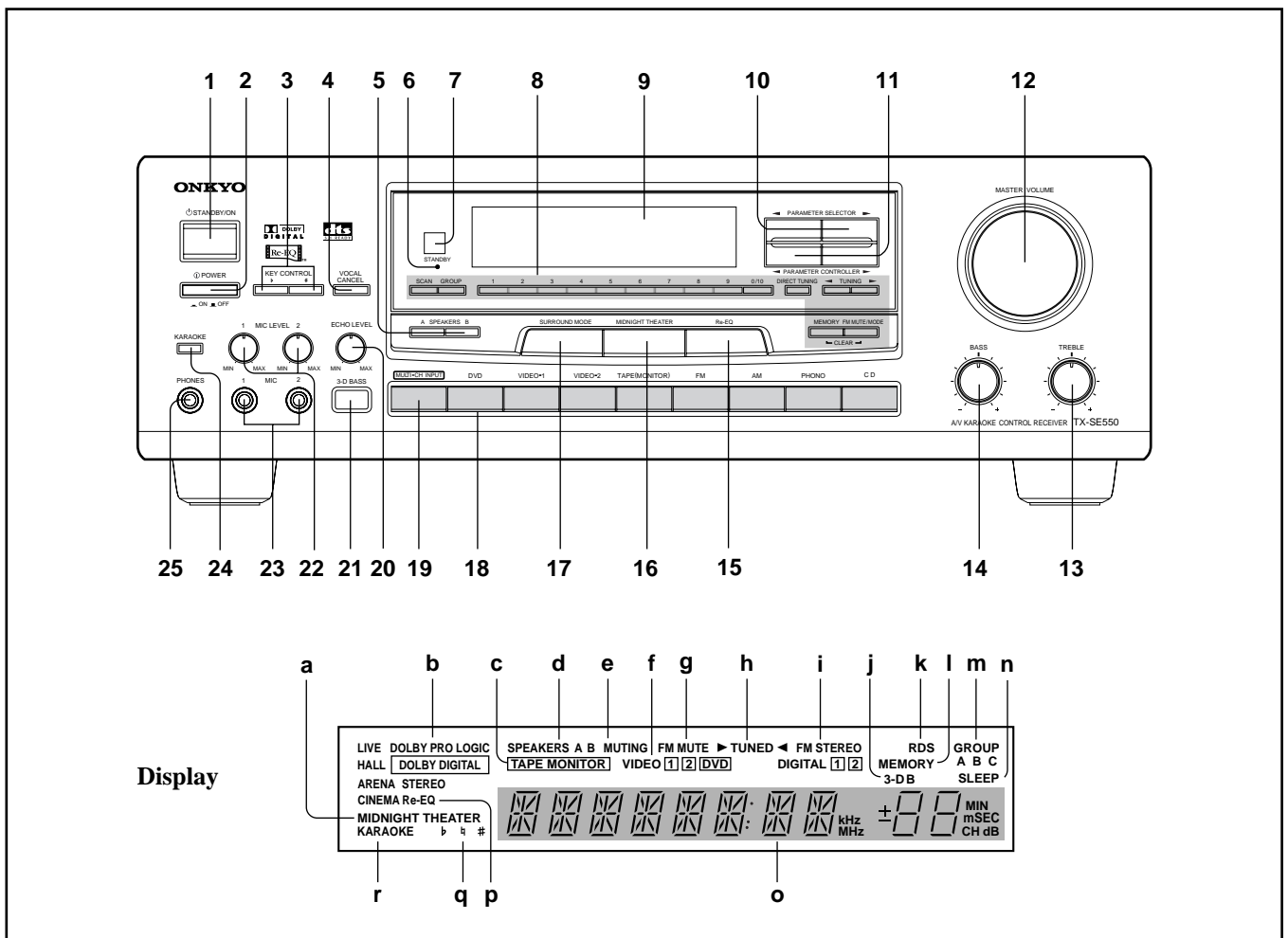

Front panel

For more information about buttons or knobs, refer to the pages listed in the brackets ([]) below.

1. STANDBY/ON button [9, 11]
2. POWER switch [9, 11]
3. Key control buttons [22, 23]
4. Vocal cancel button [22, 23]
5. SPEAKERS A/B button [16, 18]
6. STANDBY indicator [5, 11]
7. Remote control sensor [5]
8. TUNER operation buttons
SCAN button [25]
GROUP button [25]
Number buttons [16, 24, 25]
DIRECT TUNING button [24]
TUNING UP/DOWN buttons [24]
FM MUTE/MODE button [24, 25]
MEMORY button [25]
9. Display (Refer to the "Display" illustration.)
10. PARAMETER SELECTOR buttons [14, 15]
11. PARAMETER CONTROLLER buttons [14, 15]
12. MASTER VOLUME control knob [16, 20]
13. TREBLE control knob [16, 18]
14. BASS control knob [16, 18]
15. Re-EQ button [20, 21]
16. MIDNIGHT THEATER button [20, 21]
17. SURROUND MODE button [20, 21]
18. Input selector buttons [16, 20, 21]
19. MULTI CHANNEL INPUT button [17]
20. Echo level control knob [22, 23]

21. 3-D BASS button [18]
22. MIC level 1/2 knobs [22, 23]
23. MIC input 1/2 jacks [22, 23]
24. Karaoke button [22, 23]
25. PHONES jack [18]

Display

If a protective film on the surface of the screen making it difficult to read the display, remove the film.

- a. MIDNIGHT THEATER indicator
- b. Surround Mode indicators
- c. Tape Monitor indicator
- d. Speakers A/B indicators
- e. Audio Mute indicator
- f. Video input selector indicators
- g. FM Mute On/Off indicator
- h. Tuned indicators
- i. FM Stereo indicator
- j. 3-D Bass indicator
- k. RDS station received indicator (European model only)
- l. Memory indicator
- m. Group indicators
- n. Sleep indicator
- o. Multi function display
(Frequency and Preset station/Input selector/Sleep time/
Volume level)
- p. CINEMA Re-EQ indicator
- q. Key transpose indicators
- r. Karaoke indicator

Remote controller RC-386M

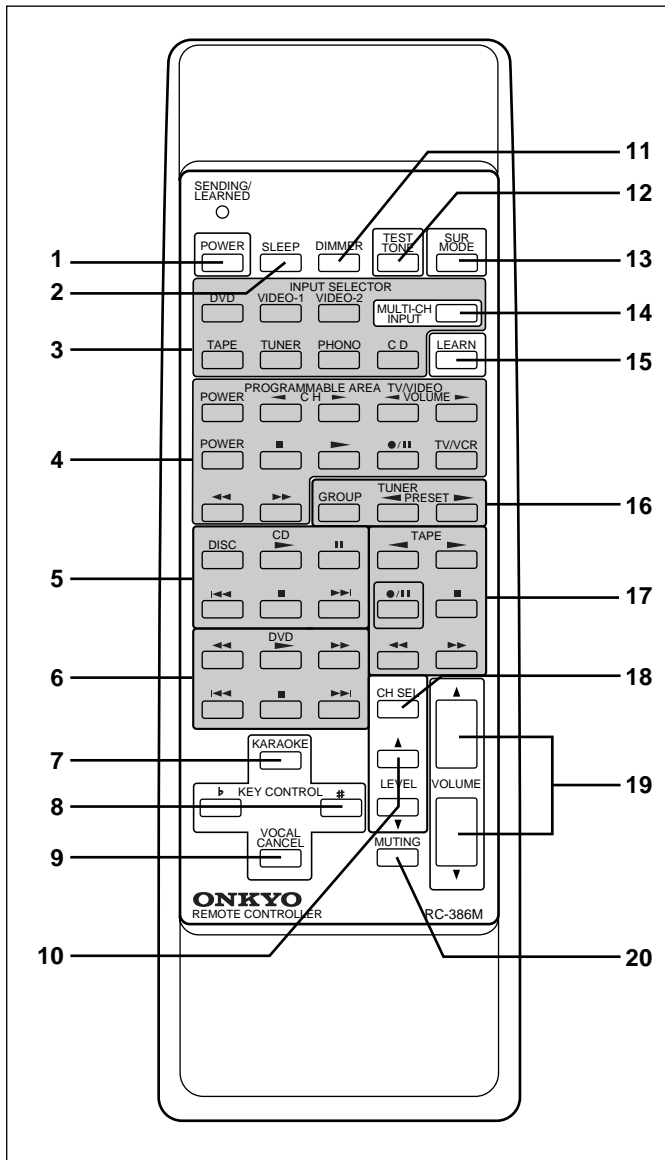

1. Power button (POWER) [11]
2. Sleep button (SLEEP) [16, 19]
3. Input selector buttons [16]
4. PROGRAMMABLE AREA buttons [28, 29]
5. CD operation buttons [34]
6. DVD operation buttons [35]
7. Karaoke button [22, 23]
8. Key control button [22, 23]
 - # : Pitch is raised in semitone steps.
 - b : Pitch is lowered in semitone steps.
9. Vocal cancel [22, 23]
10. Level up/down button (LEVEL ▲/▼) [14~17, 21]
11. DIMMER button (DIMMER) [16]
12. Test tone button (TEST TONE) [14, 15]
13. Surround mode button (SUR MODE) [20]
14. Multi channel input button [17]
15. LEARN button [28, 29]
16. Tuner operation buttons (TUNER) [25, 34]
 - GROUP: — Group selector button
 - ◀PRESET▶: — Preset memory up/down buttons
17. Tape operation buttons [34]
18. Channel selector button (CH SEL) [14~17, 21]
19. Volume buttons (VOLUME ▲/▼) [16]
 - Volume control for the Front, Center, Surround and Sub-woofer speakers.
20. Audio muting button (MUTING) [16, 19]

Using the remote controller

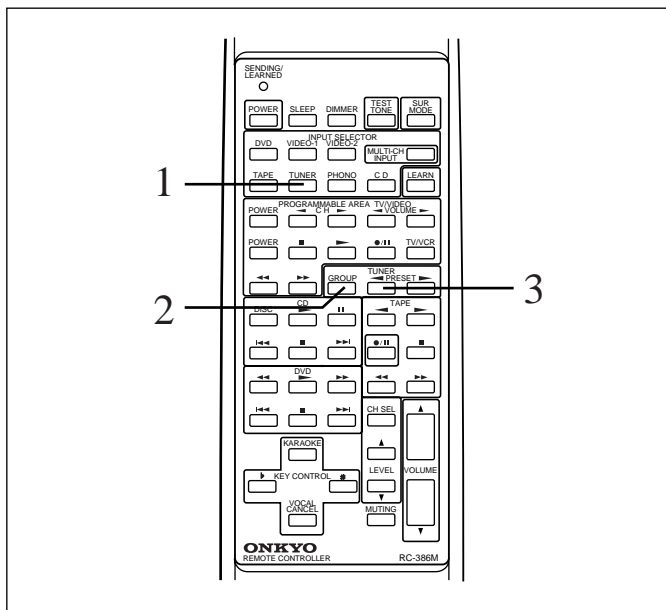

Listening to the radio

1. Press the **TUNER** button.
2. Press the **GROUP** button to select the desired **GROUP**.
3. Use the **PRESET** buttons to select the desired station.

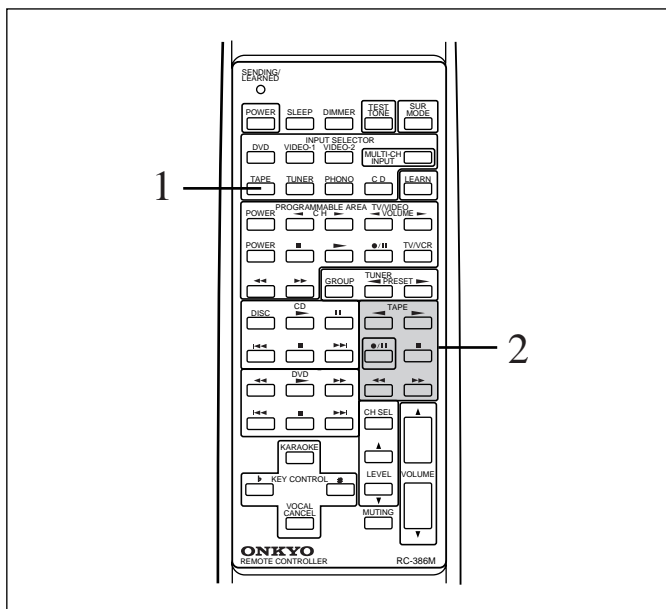

Using an Onkyo tape deck

These buttons enable you to control ONKYO cassette tape decks that can be remotely controlled. (Refer to page 9.)

1. Press the **TAPE** button.
2. Press the **transport buttons**.
 - ◀ Reverse play
 - ▶ Forward play
 - /|| Recording/pause
 - Stop
 - ◀◀ Fast Rewind
 - ▶▶ Fast Forward

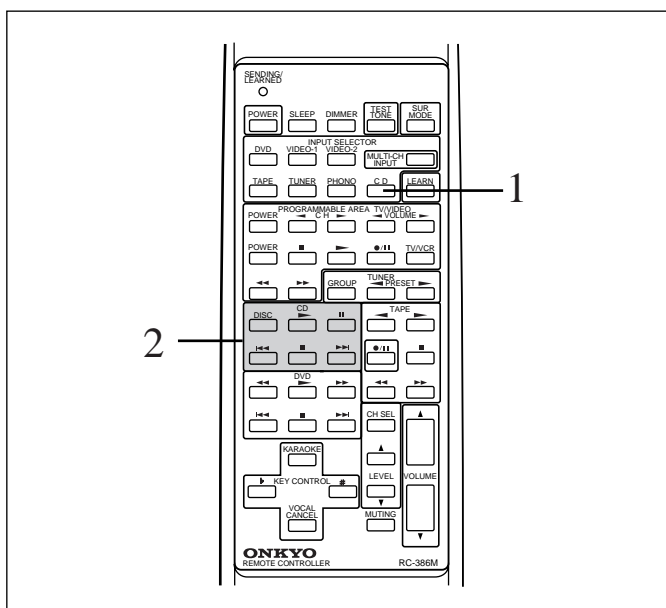

Using an Onkyo CD player

These buttons enables you to control ONKYO CD players that can be remotely controlled. (Refer to page 9.)

1. Press the **CD** button.
2. Press the **transport buttons**.
 - ▶ Play
 - || Pause
 - Stop
 - ◀◀ Down
 - ▶▶ Up
 - DISC Select a CD changer tray.

Using the remote controller

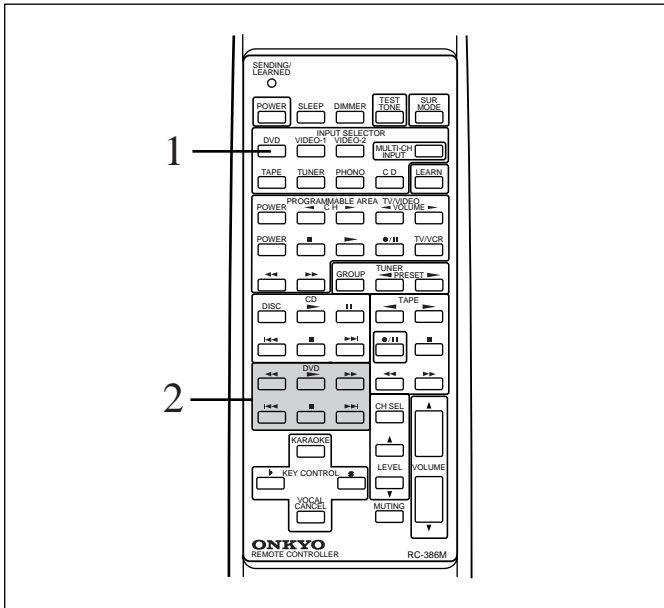

Using an Onkyo DVD player

These buttons enable you to control ONKYO DVD players that can be remotely controlled. (Refer to page 9.)

1. Press the DVD button.
2. Press the transport buttons.

- ▶ Play
- Stop
- ◀◀ Down
- ▶▶ Up
- ◀◀◀ Fast Rewind
- ▶▶▶ Fast Forward

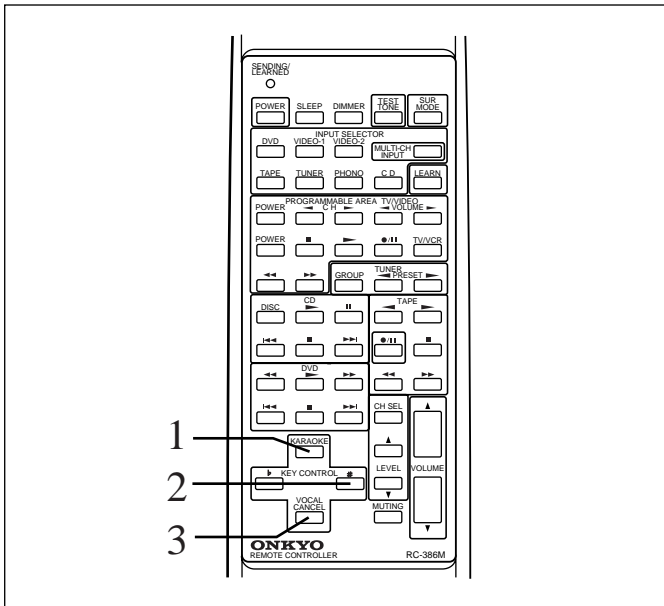

Using the Karaoke function

1. **Karaoke button**
Press this button to turn the Karaoke function ON and OFF.
2. **Key control button**
Adjusts the music in semitone steps (-6 ~ +6)
: Pitch is raised in semitone steps.
b : Pitch is lowered in semitone steps.
3. **Vocal cancel**
Selects VOCAL CANCEL mode.

ONKYO CORPORATION

Sales & Product Planning Div. : 2-1, Nisshin-cho, Neyagawa-shi, OSAKA 572-8540, JAPAN
Tel: 0720-31-8111 Fax: 0720-33-5222

ONKYO U.S.A. CORPORATION

200 Williams Drive, Ramesy, N.J. 07446, U.S.A.
Tel: 201-825-7950 Fax: 201-825-8150 E-mail: onkyo@onkyousa.com

ONKYO EUROPE ELECTRONICS GmbH

Industriestrasse 20, 82110 Germering, GERMANY
Tel: 089 84 93 20 Fax: 089 84 93 226 E-mail: info@onkyo.de

ONKYO EUROPE FRANCE BRANCH

Domaine Technologique de Saclay 4, Rue René Razel, SACLAY-91892
ORSAY CEDEX, FRANCE Tel: (1) 69 33 14 00 Fax: (1) 69 41 35 84

ONKYO CHINA LIMITED

Units 2102-7, Metroplaza Tower I, 223 Hing Fong Road, Kwai Chung,
N.T., HONG KONG Tel: 852 2429 3118 Fax: 852 2428 9039



Free Manuals Download Website

<http://myh66.com>

<http://usermanuals.us>

<http://www.somanuals.com>

<http://www.4manuals.cc>

<http://www.manual-lib.com>

<http://www.404manual.com>

<http://www.luxmanual.com>

<http://aubethermostatmanual.com>

Golf course search by state

<http://golfingnear.com>

Email search by domain

<http://emailbydomain.com>

Auto manuals search

<http://auto.somanuals.com>

TV manuals search

<http://tv.somanuals.com>