

# OPTIMUS®

Cat. No. 40-4081

## PRO SW-200P 200-Watt Powered Subwoofer

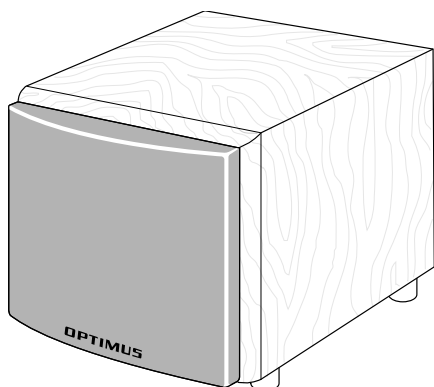

Your Optimus PRO SW-200P 200 Watt Powered Subwoofer is designed to give you the best possible low frequency sound for the ultimate home theater experience. You will be astonished by the realism it adds to movie sound effects and the power it lends to all kinds of music.

The subwoofer combines the power of a built-in 200 watt RMS amplifier with a responsive, 12-inch coated paper cone woofer — all housed in a ported bass-reflex enclosure to produce tight, floor-rumbling powerful bass (down to 36 Hz) that you can feel as well as hear!

The infrared remote control lets you turn the subwoofer on and off and regulate its volume without interrupting your listening. The LED power indicator lets you see at a glance when the subwoofer is operating.

Your subwoofer has an adjustable high cut filter and high and low level inputs so it is easy incorporation into existing systems or it as an integral part of a subwoofer/satellite combination.

It also has these features:

**Auto On/Off** — Automatically switches the PRO SW-200P's amplifier to standby if the subwoofer does not receive a signal for 8–11 minutes.

**Power Indicator** — The red LED on **VOLUME** lights when the amplifier receives an audio signal, and turns off when the amplifier goes into standby mode.

**High Level Input** — Lets you connect the PRO SW-200P to an amplifier's or receiver's speaker outputs.

**Low Level Input** — Lets you connect the PRO SW-200P to an amplifier's or receiver's line out jacks. These inputs automatically sum left and right channel information.

**Volume Control** — Lets you match the PRO SW-200P's output level to your satellite speakers' output (if used). Rotate it clockwise to increase, or counterclockwise to decrease, the subwoofer's output.

© 1998 Tandy Corporation.  
All Rights Reserved.

Optimus, Megacable, and RadioShack are registered trademarks used by Tandy Corporation.

**Frequency Hz** — Controls the high frequency cutoff point. Rotated fully clockwise, it cuts high frequencies over 200 Hz. Rotated fully counterclockwise, it cuts high frequencies over 50 Hz.

**Remote Control** — Lets you control the PRO SW-200P's volume from up to 30 feet away. Just point the remote control at the subwoofer's infrared lens.

**Note:** If you lose your remote control, the subwoofer will still operate. Simply unplug the PRO SW-200P for 10 seconds, then plug it back in. Then use **VOLUME CONTROL** to control the volume. You can order a replacement remote control through your local RadioShack store.

**WARNING:** To reduce the risk of fire or shock hazard, do not expose this product to rain or moisture.



**CAUTION:** TO REDUCE THE RISK OF ELECTRIC SHOCK, DO NOT REMOVE COVER OR BACK. NO USER-SERVICEABLE PARTS INSIDE. REFER SERVICING TO QUALIFIED PERSONNEL.



This symbol is intended to alert you to the presence of uninsulated dangerous voltage within the product's enclosure that might be of sufficient magnitude to constitute a risk of electric shock. Do not open the product's case.



This symbol is intended to inform you that important operating and maintenance instructions are included in the literature accompanying this product.

## SAFETY INSTRUCTIONS

- Never open the cabinet or remove the metal control panel, as this might result in electrical shock or damage to the unit.  
If your PRO SW-200P needs servicing, contact your local RadioShack store.
- To prevent electrical shock, do not use this polarized plug with an extension cord receptacle or other outlet unless the blades can be fully inserted to prevent blade exposure.
- Unplug the PRO SW-200P's power cord from the electrical outlet if it will be left unused for a long time.
- Only connect this unit to a power supply of the type described in the operating instructions or marked on the unit.
- Route the power-supply cord so it is not likely to be walked on or pinched by items placed upon or against it, especially at plugs, convenience receptacles, and the point where it exits from the unit.
- Placing the subwoofer on the same stand or shelf as your turntable can result in low frequency rumble or acoustic feedback.

**Cautions:**

- To prevent fire or shock, do not expose this subwoofer to rain or moisture.
- Do not place the subwoofer with its metal plate against the floor.
- Place the subwoofer away from heat sources such as radiators, stoves, or other appliances that produce heat.

**CHOOSING A LOCATION****Cautions:**

- To prevent the cabinet from warping or discoloring, do not place the subwoofer in a place where it is exposed to direct sunlight or excessive humidity.
- Do not place the subwoofer where it might be knocked over or exposed to falling objects.
- The metal control panel on the back of the PRO SW-200P acts as the heat sink for the subwoofer's internal amplifier. Therefore, place the unit at least 4 inches (10 cm) away from a wall, and do not let anything come into contact with this panel.

Where and how you position your subwoofer greatly affects its bass response. Adjusting the subwoofer's volume control in relation to the left and right speakers and adjusting the subwoofer's high cut filter also affects your speakers' overall sound.

Although low frequencies are non-directional, factors such as room reflections, standing waves, resonance and absorption strongly affect your subwoofer's performance. For maximum bass output, place your subwoofer in a corner. To reduce output, move it away from corners and back walls. Even slightly moving the subwoofer can have a major effect on bass response.

We recommend that you test the subwoofer in different locations to determine where the best balance is between your satellite speakers (if used) and subwoofer. We also recommend that you place the PRO SW-200P at least 4 inches away from the wall, and at least 2–3 feet away from your television or computer's disk drive system so the subwoofer's magnet will not distort the colors of your TV picture or erase your floppy disks.

**CONNECTING TO AN AMPLIFIER**

You can connect your PRO SW-200P to an amplifier/receiver's line out or speaker terminals.

**Note:** You can connect your PRO SW-200P to your television if your television has line out jacks.

**Caution:** To avoid any damage to the subwoofer or amplifier, disconnect power from your components before making any connections.

## Connecting to Line Out Terminals

Your amplifier/receiver's line out jacks might be labeled either REC OUT or PRE OUT.

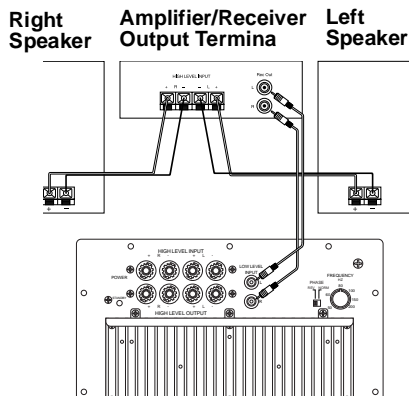

**Note:** We recommend you connect the subwoofer to an amplifier or receiver that has at least two sets of line out jacks. Connecting the subwoofer to an amplifier or receiver with only one set of line out jacks might result in no sound from the satellite speakers. If your amplifier has only one set of line out jacks, follow the instructions under "Connecting to Speaker Terminals" instead.

1. Connect the PRO SW-200P's **LOW LEVEL INPUT** jacks to the amplifier/receiver's (or TV's) line out jacks. Be sure to connect the jacks in phase, with left to left and right to right.
2. Connect your satellite speakers (if any) to the amplifier/receiver's output terminals as they would normally be connected.

**Note:** If you connect your PRO SW-200P to your amplifier/receiver's line out terminals and your amplifier/receiver has a line out selector switch, be sure to switch it to the correct source.

## Connecting to Speaker Terminals

Connect the amplifier/receiver's speaker output terminals to the PRO SW-200P's **HIGH LEVEL INPUT** terminals. Be sure to connect the terminals in phase, connecting positive (+) to positive and negative (-) to negative. Wiring the PRO SW-200P with + to - causes reduces bass performance.

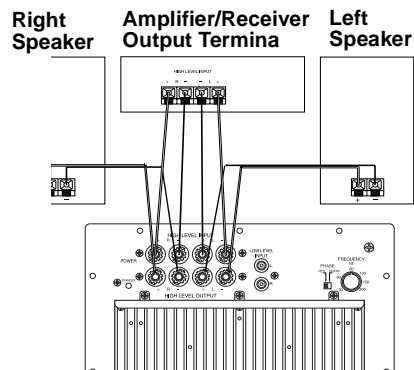

## Connecting Speakers

You can connect your left and right speakers to your amplifier/receiver (as shown in the illustration on Page 4), or to the PRO SW-200P's **HIGH LEVEL INPUT** speaker terminals (as shown above). The connection for the PRO SW-200P remains the same.

If you use MEGACABLE® or any other high quality, low gauge speaker wire, the terminals will be too small to accommodate the wires from both the left (or right) speaker and the PRO SW-200P. You need two pairs of Speaker Pins (RadioShack Unlimited No. 10458503) to make the connection. Follow these steps to connect the wires to each terminal using Speaker Pins.

1. Twist together the ends of the wires from the left speaker's positive terminal and the amplifier/receiver's left positive speaker terminal.

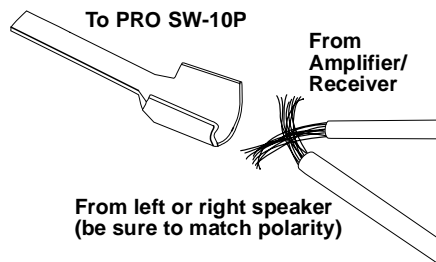

2. Position the twisted wire ends between the open barrel ends of the Speaker Pin.
3. Using a pair of pliers, crimp down the open barrel ends of the Speaker Pin to hold the wire ends in place.
4. Plug the Speaker Pin into the proper terminal on the PRO SW-200P.

## CONNECTING TO POWER

Plug the PRO SW-100P's AC power cord into an AC outlet.

## ADJUSTING THE VOLUME

Once you have made all connections, follow these steps to adjust the volume control.

1. Rotate **VOLUME CONTROL** on the front of the subwoofer to **MIN**.
2. Turn on your amplifier/receiver and another component (such as a radio, cassette player, CD player, or turntable).
3. Begin play of an audio source (such as a CD) and adjust the amplifier/speaker's overall volume to a comfortable level. Rotate **VOLUME CONTROL** clockwise, a little at a time, until you achieve a pleasing balance of bass between the PRO SW-200P and the main speakers (and satellite speakers, if used). Bass output should not overpower the main speakers, but should blend across the entire musical range.

Once you have adjusted **VOLUME CONTROL**, use the amplifier/receiver's volume control to control the speakers' volume.

## ADJUSTING THE HIGH CUT FREQUENCY

**FREQUENCY HZ** adjusts the level (between 50 Hz and 200 Hz) at which the subwoofer begins passing frequencies to other speakers. This control's setting depends on the low frequency capabilities of your satellite speakers (if used), speaker placement, and other factors that affect bass performance.

To adjust the high cut frequency, first rotate **FREQUENCY HZ** clockwise until the music sounds too bass-heavy. Then rotate it counterclockwise until the bass sounds more natural.

If the mid-bass sounds natural but you want more low bass, rotate **FREQUENCY HZ** counterclockwise a little, then rotate **VOLUME CONTROL** clockwise by about the same amount. This increases low bass output without affecting the mid-bass output.

To reduce low bass output without affecting the mid-bass output equally, rotate **FREQUENCY HZ** clockwise and **VOLUME CONTROL** counterclockwise.

**Note:** Set **FREQUENCY HZ** to 200 Hz when using the PRO SW-200P with the Mini Home Theater Satellite Speakers (RadioShack Cat. Nos. 40-4082/4083) and Mini Home Theater Center Speaker (Cat. No. 40-4084).

## CARE AND MAINTENANCE

Your Optimus PRO SW-200P 200-Watt Powered Subwoofer is an example of superior design and craftsmanship. The following suggestions will help you care for your subwoofer so you can enjoy it for years.

- Keep the subwoofer dry. If it gets wet, wipe it dry immediately. Liquids can contain minerals that corrode electronic circuits.
- Use and store the subwoofer only in normal temperature environments. Temperature extremes can shorten the life of electronic devices, and distort or melt plastic parts.
- Handle the subwoofer gently and carefully. Dropping it can damage circuit boards and cases and can cause the subwoofer to work improperly.
- Keep the subwoofer away from dust and dirt, which can cause premature wear of parts.
- Use only fresh batteries of the recommended size and type. Old batteries can leak chemicals that can damage your subwoofer's electronic circuits.

- 
- To maintain the cabinet's finish, do not let it come into contact with water vapor, alcohol, benzene, insecticide, or similar liquids. Do not place a plastic covering on top of the cabinet, as the plastic's color could come off and stick to the finish. Clean the subwoofer cabinet with a soft, dry cloth.
  - Never touch the subwoofer elements with your hands or expose them to excessive shocks. If the subwoofer is dented or bent, the sound is distorted as well.

Modifying or tampering with the subwoofer's internal components can cause a malfunction and invalidate your subwoofer's warranty. If your subwoofer is not performing as it should, take it to your local RadioShack store for assistance.

## SPECIFICATIONS

Amplifier Output .....	200 W RMS (4 Ohms @ 1% THD)
Crossover .....	50 Hz–200 Hz Variable
Frequency Response .....	36 Hz–200 Hz
Power Voltage .....	AC 120 V/60 Hz
Power Consumption .....	120W
Dimensions (HWD) .....	16 × 16 × 16 in. (407 × 407 × 407 mm)
Weight .....	45 lbs (20.412 kg)

Specifications are typical; individual units might vary. Specifications are subject to change and improvement without notice.

### Limited One-Year Warranty

This product is warranted by RadioShack against manufacturing defects in material and workmanship under normal use for one (1) year from the date of purchase from RadioShack company-owned stores and authorized RadioShack franchisees and dealers. EXCEPT AS PROVIDED HEREIN, RadioShack MAKES NO EXPRESS WARRANTIES AND ANY IMPLIED WARRANTIES, INCLUDING THOSE OF MERCHANTABILITY AND FITNESS FOR A PARTICULAR PURPOSE, ARE LIMITED IN DURATION TO THE DURATION OF THE WRITTEN LIMITED WARRANTIES CONTAINED HEREIN. EXCEPT AS PROVIDED HEREIN, RadioShack SHALL HAVE NO LIABILITY OR RESPONSIBILITY TO CUSTOMER OR ANY OTHER PERSON OR ENTITY WITH RESPECT TO ANY LIABILITY, LOSS OR DAMAGE CAUSED DIRECTLY OR INDIRECTLY BY USE OR PERFORMANCE OF THE PRODUCT OR ARISING OUT OF ANY BREACH OF THIS WARRANTY, INCLUDING, BUT NOT LIMITED TO, ANY DAMAGES RESULTING FROM INCONVENIENCE, LOSS OF TIME, DATA, PROPERTY, REVENUE, OR PROFIT OR ANY INDIRECT, SPECIAL, INCIDENTAL, OR CONSEQUENTIAL DAMAGES, EVEN IF RadioShack HAS BEEN ADVISED OF THE POSSIBILITY OF SUCH DAMAGES.

Some states do not allow the limitations on how long an implied warranty lasts or the exclusion of incidental or consequential damages, so the above limitations or exclusions may not apply to you.

In the event of a product defect during the warranty period, take the product and the RadioShack sales receipt as proof of purchase date to any RadioShack store. RadioShack will, at its option, unless otherwise provided by law: (a) correct the defect by product repair without charge for parts and labor; (b) replace the product with one of the same or similar design; or (c) refund the purchase price. All replaced parts and products, and products on which a refund is made, become the property of RadioShack. New or reconditioned parts and products may be used in the performance of warranty service. Repaired or replaced parts and products are warranted for the remainder of the original warranty period. You will be charged for repair or replacement of the product made after the expiration of the warranty period.

This warranty does not cover: (a) damage or failure caused by or attributable to acts of God, abuse, accident, misuse, improper or abnormal usage, failure to follow instructions, improper installation or maintenance, alteration, lightning or other incidence of excess voltage or current; (b) any repairs other than those provided by a RadioShack Authorized Service Facility; (c) consumables such as fuses or batteries; (d) cosmetic damage; (e) transportation, shipping or insurance costs; or (f) costs of product removal, installation, set-up service adjustment or reinstallation.

This warranty gives you specific legal rights, and you may also have other rights which vary from state to state.

RadioShack Customer Relations, Dept. W, 100 Throckmorton St., Suite 600, Fort Worth, TX 76102

*We Service What We Sell*

3/97

**RadioShack**  
**A Division of Tandy Corporation**  
**Fort Worth, Texas 76102**

5A8N

Printed in the USA



## Free Manuals Download Website

<http://myh66.com>

<http://usermanuals.us>

<http://www.somanuals.com>

<http://www.4manuals.cc>

<http://www.manual-lib.com>

<http://www.404manual.com>

<http://www.luxmanual.com>

<http://aubethermostatmanual.com>

Golf course search by state

<http://golfingnear.com>

Email search by domain

<http://emailbydomain.com>

Auto manuals search

<http://auto.somanuals.com>

TV manuals search

<http://tv.somanuals.com>