

OPTIMUS®

*Professional Series*

# Digital Synthesize AM/FM Stereo Receiver STA-3500

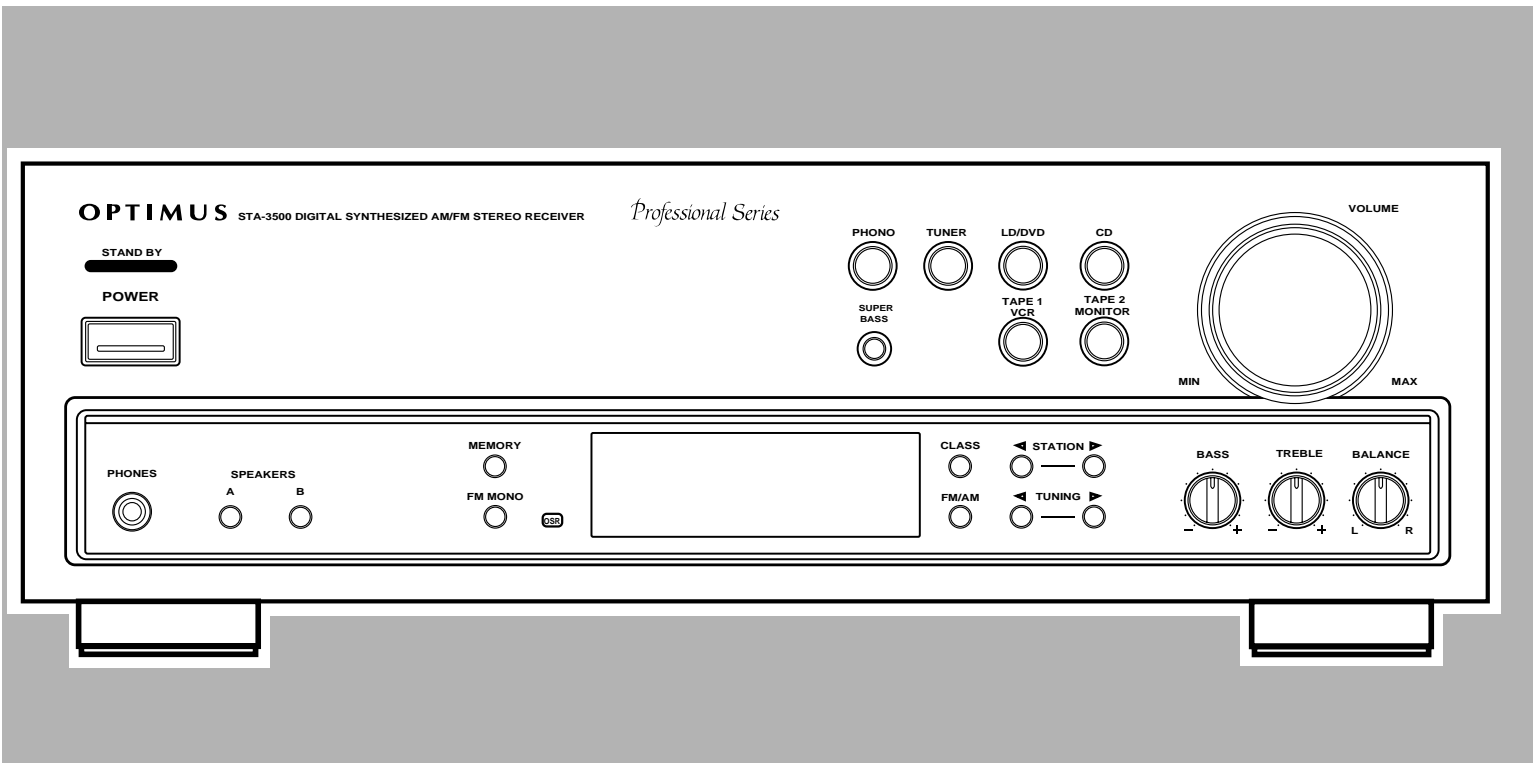

# Introducing the Optimus STA-3500

Your Optimus STA-3500 Digital Synthesized AM/FM Stereo Receiver is the perfect control center for your audio/video system. It combines 100 watts-per-channel of clean power with modern styling. It provides connections for two tape decks, a turntable, a CD player, and one other audio source, such as audio from a digital video disk (DVD) player. You can also connect up to two pairs of speakers (not provided) to your receiver.

Additional features include:

**Digital-Synthesized Tuner** Precisely tunes to AM and FM stations.

**Automatic Tuning** Lets you search for the next available FM station.

**30 Memory Locations** Let you store and recall the frequencies for up to 30 radio stations.

**Tape Monitoring** Lets you listen to the actual recording as you record, if your tape deck has a tape-monitoring feature. Also lets you listen to a tape playing in TAPE 2 while TAPE 1 continues to record the program you selected.

**Built-In Protection Circuits** Turn off the receiver to help prevent damage if a power surge or short circuit occurs.

**Remote Control** Lets you use a single remote control for the receiver and other compatible components connected to the receiver.

We recommend you record the receiver's serial number here. The serial number is on the receiver's back panel.

Serial Number: \_\_\_\_\_

© 1996 Tandy Corporation.  
All Rights Reserved.



Optimus is a registered trademark used by Tandy Corporation.  
RadioShack is a trademark used by Tandy Corporation.

# IMPORTANT SAFETY INSTRUCTIONS

This receiver is made and tested to meet exacting safety standards. It meets both UL and FCC requirements.

**WARNING: TO REDUCE THE RISK OF FIRE OR ELECTRIC SHOCK, DO NOT EXPOSE THIS APPLIANCE TO RAIN OR MOISTURE.**

To prevent fire or shock hazard, do not expose this system to rain or moisture.

	<b>CAUTION</b> RISK OF ELECTRIC SHOCK. DO NOT OPEN.	
<b>CAUTION: TO REDUCE THE RISK OF ELECTRIC SHOCK, DO NOT REMOVE COVER OR BACK. NO USER-SERVICEABLE PARTS INSIDE. REFER SERVICING TO QUALIFIED PERSONNEL.</b>		



This symbol is intended to alert you to the presence of uninsulated dangerous voltage within the system's enclosure that might be of sufficient magnitude to constitute a risk of electric shock. Do not open the system's case.



This symbol is intended to inform you that important operating and maintenance instructions are included in the literature accompanying this system.

## CAUTION

**Power Lines**—Locate an outdoor antenna away from power lines.

**Nonuse Periods**—Unplug the receiver's power cord when you will not use it for extended periods.

**Outdoor Antenna Grounding**—If an outside antenna or cable system is connected to the receiver, ground the antenna or cable system so as to provide some protection against voltage surges and built-up static charges. Article 810 of the National Electrical Code, ANSI/NFPA 80, provides information about proper grounding of the mast and supporting structure, grounding of the lead-in wire to an antenna discharge unit, size of grounding conductors, location of antenna-discharge unit, connection to grounding electrodes, and requirements for the grounding electrode. See the example below.

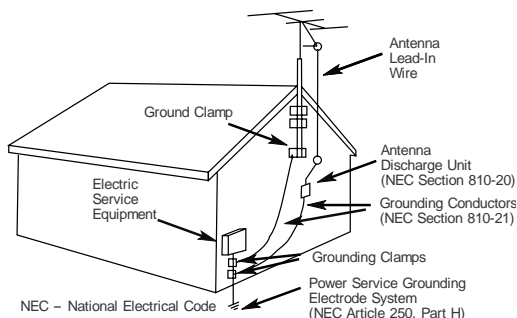

Careful attention is devoted to quality standards in the manufacture of your receiver, and safety is a major factor in its design. However, safety is also your responsibility.

This section lists important information that will help you properly use and enjoy your receiver and accessories. Read all the included safety and operating instructions before using your receiver. Follow them closely, and retain them for future reference.

**Heed Warnings** — Follow all warnings on the product and in the operating instructions.

**Cleaning** — Unplug this product from the wall outlet before cleaning. Use only a damp cloth for cleaning. Do not use liquid or aerosol cleaners.

**Attachments** — Do not use attachments/accessories not recommended by the product manufacturer, as they might create a hazard.

**Water and Moisture** — Do not use this product near water (for example, near a bathtub, washbowl, kitchen sink, or laundry tub; in a wet basement; or near a swimming pool).

**Accessories** — Do not place this product on an unstable cart, stand, tripod, bracket, or table. The product may fall, causing serious injury to a child or adult, and serious damage to the product. Use only with a cart, stand, tripod, bracket, or table recommended by the manufacturer or sold with the product. Follow the manufacturer's instructions for mounting, and use a recommended mounting accessory.



**Carts** — Move the product on a cart carefully. Quick stops, excessive force, and uneven surfaces may cause the product/cart to overturn.

**Ventilation** — Slots and openings in the cabinet provide ventilation, ensure reliable operation, and protect from overheating. Do not block or cover these openings, and do not place the product on a bed, sofa, rug, or other similar surface. Do not place the product in a built-in bookcase or rack unless it provides proper ventilation as specified by the manufacturer.

**Power Sources** — Operate this product using only the power source indicated on its marking label. If you are not sure of your home's power type, consult your product dealer or local power company.

**Polarization** — This product is equipped with a polarized AC line plug (a plug having one blade wider than the other). This plug will fit in the power outlet only one way. This is a safety feature. If you cannot insert the plug fully into the outlet, try reversing the plug. If the plug still doesn't fit, contact your electrician to replace your obsolete outlet. Do not defeat the safety purpose of the polarized plug. If you need an extension, use a polarized cord.

**Power-Cord Protection** — Route power-supply cords so they are not likely to be walked on or pinched by items placed on or against them, paying particular attention to cords at plugs, convenience receptacles, and the point where they exit from the product.

**Lightning** — For added protection for this product during a lightning storm, or when it is left unattended and unused for long periods of time, unplug it from the wall outlet and disconnect the antenna or cable system. This will prevent damage to the product due to lightning and power-line surges.

**Overloading** — Do not overload wall outlets, extension cords, or integral convenience receptacles, as this can result in a risk of fire or electric shock.

**Objects and Liquids** — Never push objects of any kind into this product through openings, as they may touch dangerous voltage points or short out parts that could result in a fire or electric shock. Never spill liquid of any kind on the product.

**Servicing** — Do not attempt to service this product yourself, as opening or removing covers may expose you to dangerous voltage or other hazards. Refer all servicing to qualified service personnel.

**Damage Requiring Service** — Unplug this product from the wall outlet and refer servicing to qualified service personnel under the following conditions:

- When the power-supply cord or plug is damaged.
- If liquid has been spilled or objects have fallen into the product.
- If the product has been exposed to rain or water.
- If the product does not operate normally by following the operating instructions. Adjust only those controls that are covered by the operating instructions, as an improper adjustment of other controls may result in damage and will often require extensive work by a qualified technician to restore the product to normal operation.
- If the product has been dropped or damaged in any way.
- When the product exhibits a distinct change in performance.

**Replacement Parts** — When replacement parts are required, be sure the service technician uses replacement parts specified by the manufacturer or having the same characteristics as the original part. Unauthorized substitutions may result in fire, electric shock, or other hazards.

**Safety Check** — Upon completion of service or repairs to this product, ask the service technician to perform safety checks to determine that the product is in proper operating condition.

**Wall or Ceiling Mount** — The product should be mounted to a wall or ceiling only as recommended by the manufacturer.

**Heat** — The product should be situated away from heat sources such as radiators, heat registers, stoves, or other products (including amplifiers) that produce heat.

# Contents

<b>Preparing Your Receiver</b> .....	<b>5</b>
Positioning Speakers .....	5
Connecting Speakers .....	6
Connecting Program Sources .....	8
Connecting the Antennas .....	9
Using One Remote Control for More Than One Unit .....	11
Installing the Remote Control's Batteries .....	11
Using the AC Power Outlet .....	12
Connecting to AC Power .....	12
<b>Basic Operation</b> .....	<b>13</b>
Tuning the Radio .....	14
Using FM Mono .....	15
Balance Control .....	15
Muting the Receiver .....	15
Using Headphones .....	15
Cassette Deck Features .....	15
<b>Using the Remote Control</b> .....	<b>18</b>
<b>Troubleshooting</b> .....	<b>20</b>
<b>Care and Maintenance</b> .....	<b>21</b>
<b>The FCC Wants You to Know</b> .....	<b>22</b>
<b>Specifications</b> .....	<b>23</b>
<b>Index to Features by Control Name</b> .....	<b>25</b>

# Preparing Your Receiver

**Caution:** Make all the necessary connections before you plug in or turn on the receiver.

## Positioning Speakers

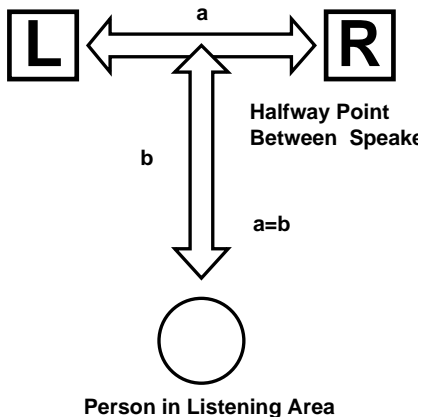

Where you place your speakers can make a noticeable difference in your system's sound. The guidelines in this section will help you choose the best locations. After you use your receiver for a while, you might want to try different locations for your speakers.

Bass response depends largely on speaker location. For strong bass, place the speakers in the corners of the room. If you want even stronger bass, place the speakers directly on the floor. If the bass is too strong, move the speakers slightly away from the corners of the room, or raise them 6 to 18 inches off the floor. You can buy speaker stands at your local RadioShack store.

The distance between the speakers should be about the same as the distance between the normal listening point and the point halfway between the speakers. If you place the speakers too close together, you reduce the stereo separation. If you place them too far apart, you reduce the bass effect and create a *hole* in the middle of the sound.

Most speakers have a tweeter dispersion angle of about 60 degrees. Ideally, your listening position should be just inside the overlap area of the tweeter dispersion. You can angle the speakers toward you for better stereo effect.

## Connecting Speakers

Follow these guidelines when you select and connect speakers.

- Only connect speakers that are rated at between 8 and 16 Ohms.
- Be sure you properly connect all speakers.
- Do not connect two pairs of speakers to a single set of terminals (A or B) at the same time. When you use two pairs of speakers, connect one set to **Speakers A** and one set to **Speakers B**.
- Realistic, Optimus, and other high-quality speakers have color-coded speaker terminals (red for positive polarity and black for negative polarity). Use these color-coded terminals as a guide to help you properly connect the speakers to the receiver.
- Use 16-gauge (or larger) speaker wire for all speaker connections, and consider possible speaker locations before you decide how much speaker wire you need.

## Preparing the Speaker Wires

Speaker wire consists of two conductors (individual wires) encased in insulation and is usually color-coded or marked with a ridge along one side so you can identify each conductor. Use these markings as a guide to help you properly connect the speakers to your receiver.

Follow these steps to prepare the speaker wires.

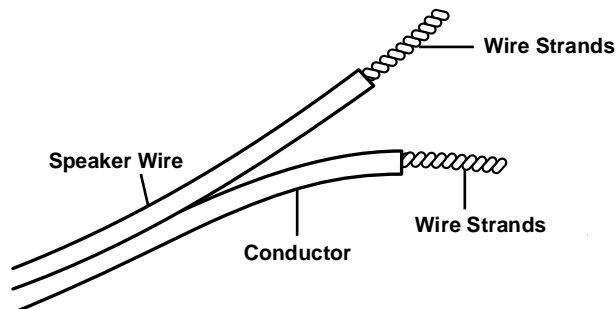

1. Cut the speaker wires to the necessary length.
2. Separate the wires about 4 inches on each end.
3. Using a wire stripper, carefully strip about  $\frac{3}{4}$  inch of insulation from the end of each conductor.
4. Twist the end of each conductor to secure any loose wire strands.

## Notes:

- Be sure you connect the receiver's right and left positive (+) and negative (-) terminals to the speaker's corresponding right and left positive (+) and negative (-) terminals.
- Fully insert the speaker wires to ensure a good connection. Leave extra wire at the back of the receiver so you do not disconnect the wires when you move the receiver.

**Caution:** To prevent a short circuit, twist the end of each conductor to be sure that stray speaker wire strands do not touch other speaker terminals or any other receiver terminals.

## Connecting the A and B Speakers

Follow these steps to connect the right speaker to the receiver's right **A SPEAKERS** terminals.

1. Press the receiver's **A SPEAKERS R (+)** red lever and insert the ridged or color-coded conductor's end into the small hole. Pull back the lever to secure the conductor.

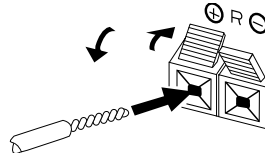

2. Press the receiver's **A SPEAKERS R (-)** black lever and insert the other conductor's end into the small hole. Pull back the lever to secure the conductor.
3. Connect the ridged or color-coded conductor's loose end to the right speaker's positive (+) terminal.
4. Connect the remaining loose conductor to the right speaker's negative (-) terminal.

Repeat Steps 1 through 4 to connect the left speaker to the receiver's **A SPEAKERS L** terminals.

Repeat this entire process to connect a second pair of speakers to the **B SPEAKERS** terminals.

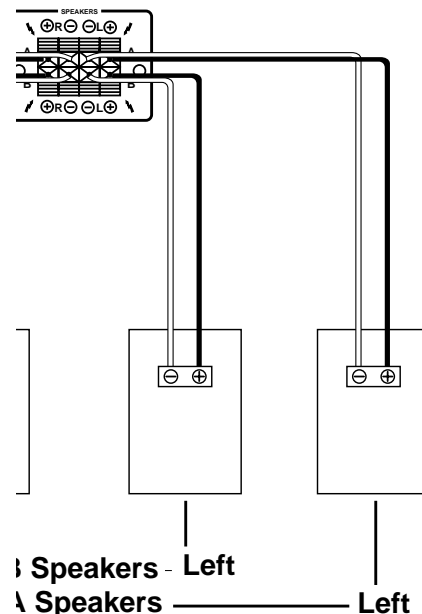

## Preparing Your Receiver

### Connecting Program Sources

You can connect up to five external program sources to your receiver.

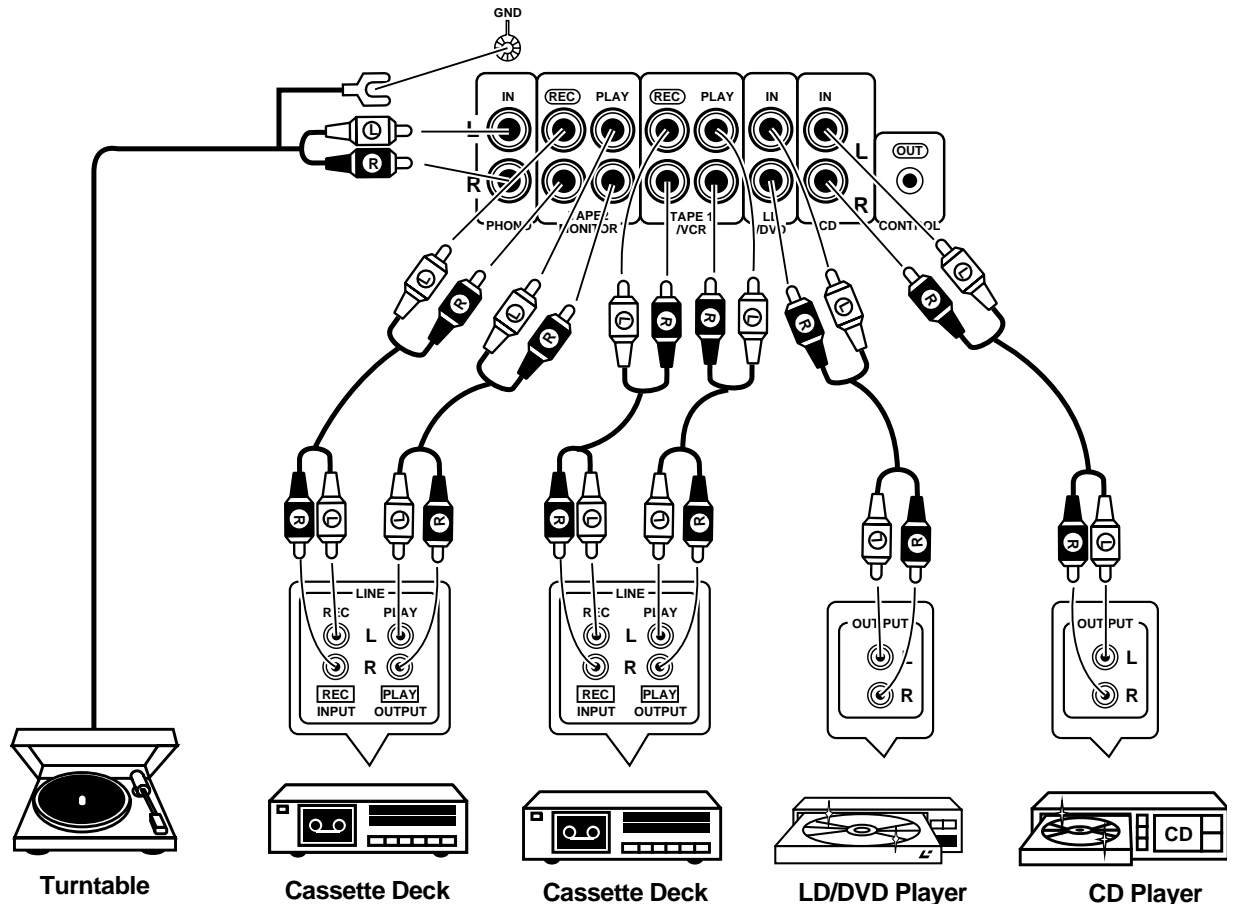

*Note: Use shielded audio cables with phono connectors for all audio connections.*

#### Connecting a Turntable

Connect a turntable with a magnetic cartridge only. Some older turntables use a ceramic-type cartridge that does not work with this system.

Connect the turntable's left and right cables to the receiver's left and right **PHONO** jacks. Then connect the turntable's ground wire to the receiver's **GND** terminal.

#### Connecting Cassette Deck(s)

You can connect cassette decks to the **TAPE 1/VCR** and the **TAPE 2 MONITOR** jacks. Connect the cassette deck's output jacks to the **TAPE 1/VCR PLAY** or **TAPE 2 MONITOR PLAY** jacks, and connect the cassette deck's input jacks to **TAPE 1/VCR REC** (audio) or **TAPE 2 MONITOR REC** jacks.

#### Connecting a CD Player

To connect a CD player to the receiver, connect the CD player's left and right output jacks to the receiver's **L** and **R CD IN** jacks.

#### Connecting Another Audio Source

Connect the audio outputs of another audio source, such as the audio from a laser disc player, TV, VCR, or CD player, to the **LD/DVD IN L** and **R** jacks.



## Connecting the Antennas

**Warning:** To prevent injury, read and follow all cautions and warnings that accompany the outdoor antenna.

In many cities, the supplied indoor AM loop and FM antennas provide adequate reception.

### AM Antennas

Assemble the included antenna's base by swinging the base in the direction of the arrow and inserting the antenna's bottom tabs into the base's slot. Then attach the antenna wires to the **AM LOOP ANTENNA** and **GND** terminals.

Place the antenna on a flat surface and rotate it for the best AM reception.

If the receiver is in a rack or on a shelf and there is no room for the AM loop antenna, use two screws (not supplied) to mount the base on the wall or another location as shown.

#### Notes:

- Keep the AM loop antenna connected even when you use another indoor antenna or an outdoor AM antenna.
- Ensure the antenna does not touch the receiver or other metal objects.
- Do not place the antenna near a CD player, a personal computer, or a TV set
- If the wire between your AM loop antenna and receiver is too short, you can add extra wire, available at your local RadioShack store.

You can also use a RadioShack shortwave antenna kit (Cat. No. 278-758), which makes an excellent outdoor AM antenna.

Connect the outdoor AM antenna wire to the receiver's AM terminal, as shown.

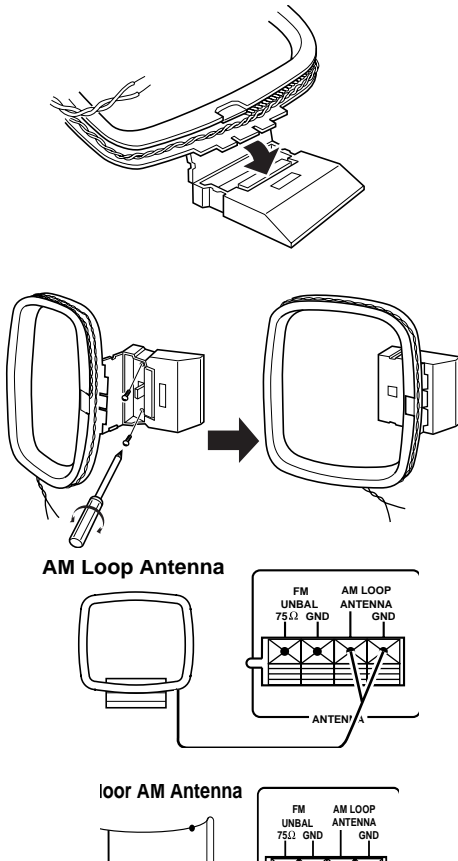

### FM Antennas

Connect the supplied FM antenna to the **FM UNBAL 75Ω** terminal and extend it as shown.

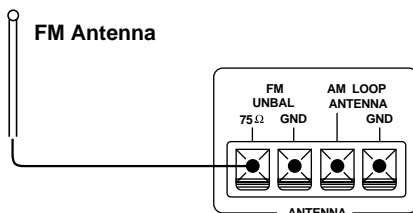

**Note:** For the best results, use 75-ohm coaxial cable to connect an outdoor antenna to the receiver.

For better FM reception, you can also use a rabbit-ear TV antenna (for indoor use only) or an outdoor VHF TV antenna. To connect the TV antenna to the receiver, you need a VHF/UHF/FM splitter (not included). RadioShack stores carry a full line of quality outdoor antennas and antenna connection accessories.

## Preparing Your Receiver

For the best radio reception, use an outdoor antenna. Follow these steps to connect an outdoor FM antenna to the receiver using 75Ω cable.

**Note:** If your antenna has 300Ω twin-lead cable, consult your local RadioShack store for the correct adapter.

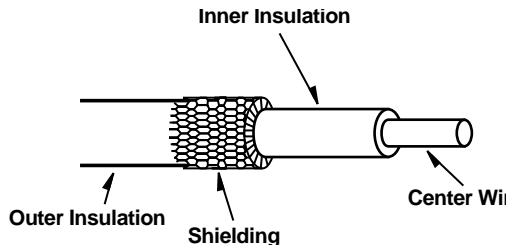

**Caution:** The cable's shielding should only touch the GND terminal.

1. Disconnect the supplied FM antenna from the receiver's **FM UNBAL 75Ω** terminal.
2. With a stripping tool, remove about 1 1/2 inches of the 75Ω cable's outer insulation to expose the cable's shielding.
3. Fold back the insulation from the inner insulation.
4. Remove about 1 inch of the inner insulation from around the center wire.
5. Pull the shielding to one side. Connect the center wire to the receiver's **FM UNBAL 75Ω** terminal. Twist the shielding to secure any loose wire strands, and connect it to the **GND** terminal.

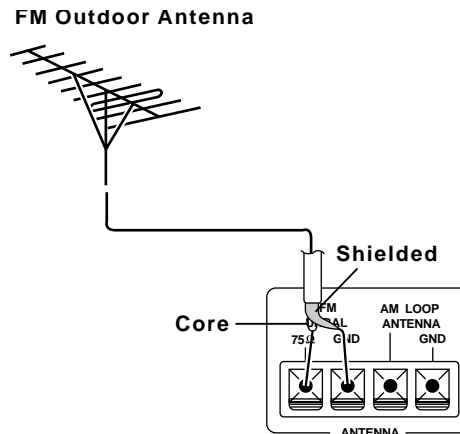

**Note:** Grounding is not necessary for reception, but we recommend it to avoid damage from lightning when you use an outdoor FM antenna and for better FM reception. Use a separate piece of thick polyvinyl insulated wire to connect the **GND** terminal to an earth ground such as a metal cold-water pipe.

**Warning:** Never connect a wire to a gas pipe for grounding since sparks might ignite the gas.

## Using One Remote Control for More than One Unit

**Note:** When you plug the cable into a component's **CONTROL IN** jack, that component's remote sensor does not function.

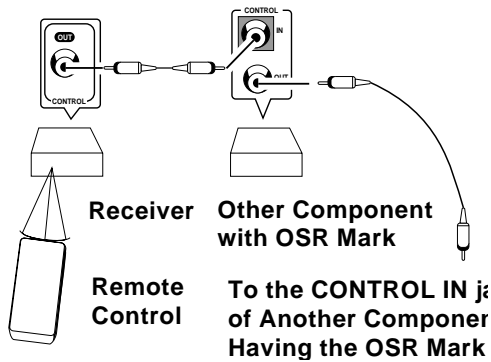

If you also have an Optimus professional series CD player, VCR, or cassette deck with the OSR mark, you can connect its **CONTROL IN** jack to the receiver so you can control all of your equipment with a single remote control. You can also use the other component's remote control by pointing it at the receiver's front panel.

1. Connect each component to the receiver as shown in "Connecting Program Sources."

**Note:** You must connect the audio cables between the receiver and the other audio accessory to use your receiver's remote control to control the accessory.

2. Connect the cable supplied with the CD player, VCR, or cassette deck between the receiver's **CONTROL OUT** jack and the other component's **CONTROL IN** jack.
3. When you want to control more than one other component using the receiver's remote control, daisy-chain the **CONTROL OUT** and **CONTROL IN** connections as shown.

## Installing the Remote Control's Batteries

The remote control uses two AA batteries (not included). For the longest battery life, we recommend alkaline batteries (such as RadioShack Cat. No. 23-557).

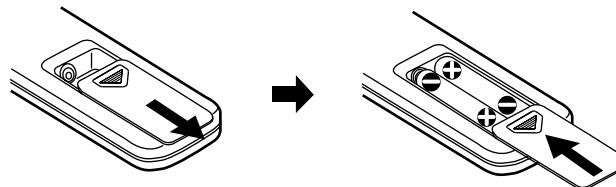

1. Press and remove the battery compartment cover.
2. Place two fresh AA batteries in the compartment as indicated by the polarity symbols (+ and -) marked in the compartment.
3. Replace the battery compartment cover.

### Cautions:

- Use only fresh batteries of the recommended size and type.
- Always remove old or weak batteries. Batteries can leak chemicals that can damage electronic circuits.

**Note:** If the remote's range is reduced, replace the batteries immediately.

## Preparing Your Receiver

### Using the AC Power Outlet

**Caution:** Do not connect appliances with high power consumption, such as a heater, iron, monitor, or TV, to this AC outlet. Doing so can cause a risk of overheating and fire, and could damage the receiver.

Your receiver has an AC power outlet that you can use to power an electronic device, such as a turntable, cassette deck, VCR, and so on. This switched outlet turns on and off with the receiver and provides a maximum of 100 Watts (0.8A max).

### Connecting to AC Power

Before you plug in the receiver's power cord, double check all other connections.

To power the receiver, plug the supplied power cord into a standard AC outlet. The power cord's plug is polarized and fits only one way.

The **STAND BY** indicator lights whenever you supply power to the receiver and turn it off.

**Warning:** To prevent electric shock, do not use this polarized plug with an extension cord, receptacle, or other outlet unless you can fully insert the blades to prevent blade exposure.

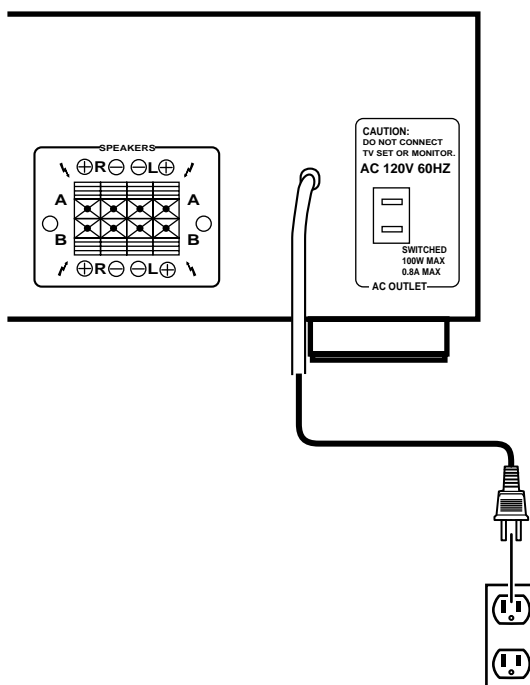

# Basic Operation

**Warning:** To prevent possible hearing loss, turn **VOLUME** to **MIN** before you turn on the receiver or change the program sources. After you turn on the receiver or change the program source, adjust **VOLUME** to a comfortable listening level.

**Note:** If you want to find out what a particular button or control is used for, see Page 18 (for the remote control) or Page 25 (for the front panel) to find the page where the button or control is described.

**Note:** If you select a source while **TAPE 2 MONITOR** is engaged, **TAPE 2** flashes five times on the display, reminding you to disengage the **TAPE 2 MONITOR** function.

**Note:** The controls on the remote control work the same as the buttons on the receiver's front panel.

Follow these steps to use the receiver.

1. Press **POWER** to turn on the receiver's power. It takes about 5 seconds to begin hearing sound.

2. Select the speakers.

**If you connected speakers only to the A (or B) SPEAKERS terminals,** press **SPEAKERS A** (or **B**) to turn on only those speakers. Do not press both **SPEAKERS A** and **B**. Doing so disconnects all speakers.

**If you connected speakers to both the A and B SPEAKERS terminals,** do any of the following:

- Press in **SPEAKERS A** or **B** to turn on either pair of speakers for a two-speaker stereo effect.
- Press in **SPEAKERS A** and **B** to turn on both pairs of speakers for a four-speaker stereo effect.
- Press **SPEAKERS A** and **B** to the *out* position to silence all speakers and listen privately with headphones (see "Using Headphones" on Page 15).

3. Select a program source.

**To tune to a radio station,** see "Tuning the Radio" on Page 15.

**To listen to signals from the component connected to TAPE 2 MONITOR,** press **TAPE 2 MONITOR** so **TAPE 2** appears on the display.

**To listen to a source other than one connected to TAPE 2 MONITOR,** be sure **TAPE 2** does not show on the display. If necessary, press **TAPE 2 MONITOR** so **TAPE 2** disappears.

Then press **TAPE 1/VCR**, **LD/DVD**, **CD**, **TUNER**, or **PHONO**, or repeatedly press **FUNCTION** on the remote control, to display the desired program source.

4. Adjust **VOLUME** clockwise to increase the volume and counterclockwise to decrease it. Or, you can use **VOLUME -/+** on the remote control.
5. Use the **BASS** and **TREBLE** controls to adjust the program's tonal quality.  
To enhance the bass level, press **SUPER BASS**.
6. Adjust **BALANCE** to suit your listening preferences. See "Balance Control" on Page 14.
7. Press **POWER** to turn off the receiver.

### Tuning the Radio

**Note:** For weak signals, we recommend manual tuning.

Your receiver offers three types of electronic tuning—manual, automatic, and memory.

#### Manual and Automatic Tuning

Follow these steps to manually or automatically tune to the stations.

1. Press **TUNER**. Then press **FM/AM** to select the desired band.

The receiver tunes to and displays the frequency last selected in that band.

2. Press **TUNING ►** or **◄** once to move to the next higher or lower frequency. Or, press and hold down **TUNING ►** or **◄** to rapidly change frequencies. Release the button to stop.

To search for the next higher or lower FM station, release **TUNING ►** or **◄** as soon as the frequency starts to change. The receiver searches up or down the FM band until it finds a strong station.

#### Notes:

- **STEREO** appears on the display when FM broadcasts are received in stereo and the receiver is not set to FM mono. **TUNED** appears on the display when you tune to a strong station. To find a weak FM station, press **FM MONO** until **MONO** appears. See “Using FM Mono” on Page 15.
- If you press **TUNING ►** at the top of the frequency range or **TUNING ◄** at the bottom of the frequency range, the display returns to the other end of the range.

#### Memory Tuning

Memory tuning lets you instantly tune to a stored frequency. You can store up to 30 AM or FM frequencies (10 frequencies in each of three classes) in the receiver’s memory.

Follow these steps to store a station.

1. Press **TUNER**. Then press **FM/AM** to select the desired band.
2. Using either manual or automatic tuning, select the frequency you want to store.

If desired, press **FM MONO** for FM monaural sound (see “Using FM Mono” on Page 16). This setting is stored in the memory.

3. Press **MEMORY**. **MEMORY** appears for 5 seconds.
4. While **MEMORY** is on the display, press **CLASS** until the class number you want (1-3) appears on the display. Then press **STATION ►** or **◄** until the station number you want appears on the display.

Repeat these steps to store additional frequencies. Do not enter a frequency while the display flashes.

To tune to a stored frequency, press **CLASS** so the desired class number appears on the display, then press **STATION ◄/►** to select the station.

#### Notes:

- If you store a frequency in a memory that already contains a frequency, you replace the previous frequency.
- If your receiver is disconnected from AC power for several days, it loses all the stored frequencies.

### Using FM Mono

To receive FM stations in stereo, press **FM MONO** until **MONO** disappears from the display. **STEREO** appears on the display when you receive an FM broadcast in stereo.

You can improve the reception of weak FM stations by pressing **FM MONO** until **MONO** appears. This reduces noise while you listen to a weak FM station, but you get monaural instead of stereo sound.

---

### Balance Control

The **BALANCE** control lets you adjust the sound balance between the left and right speakers. If you properly position the speakers and your listening area is centered between them, the center control setting is usually best (see "Positioning Speakers" on Page 5).

For an unusual speaker placement, adjust **BALANCE** as follows:

1. Select **TUNER**. Then press **FM/AM** to select the FM band.
2. Press **FM MONO** until **MONO** appears. The sound is monaural instead of stereo, so each speaker delivers the same output.
3. Turn **BALANCE** until you hear the sound coming equally from each speaker when you are in the listening area.
4. Press **FM MONO** until **MONO** disappears from the display.

---

### Muting the Receiver

To temporarily mute the sound, press **MUTING** on the remote control. **MUTING** appears. Press **MUTING** again to restore the audio level.

---

### Using Headphones

To listen with headphones (not supplied), insert the headphones' 1/4-inch plug into the receiver's front panel **PHONES** jack. To silence the speakers, set **A** and **B SPEAKERS** to the out position.

### Listening Safely

To protect your hearing, note the following when using headphones.

- Set the volume to its lowest setting before you begin listening. After you begin listening, adjust volume to a comfortable level.
- Do not listen at extremely high volume levels. Extended high-volume listening can lead to permanent hearing loss.
- Once you set the volume, do not increase it. Over time, your ears adapt to the volume level, so a volume level that does not cause discomfort might still damage your hearing.

---

### Cassette Deck Features

You can connect two cassette decks to the receiver. Selecting either **TAPE 1/VCR** or **TAPE 2 MONITOR** lets you hear the playback from the cassette deck you connected to the receiver's corresponding (**TAPE 1/VCR**, **TAPE 2 MONITOR**) jacks.

### Using the TAPE 1/VCR Button

Press **TAPE 1/VCR**. **TAPE 1** appears on the display. You hear the playback from the cassette deck or VCR you connected to the receiver's **TAPE 1/VCR** jacks.

### Using the TAPE 2 MONITOR Button

Press **TAPE 2 MONITOR**. **TAPE 2** appears on the display along with the last program source you selected. You can hear playback or monitor a recording from the cassette deck you connected to the receiver's **TAPE 2 MONITOR** jacks.

The **TAPE 2 REC** jacks continue to output the previously selected source when you press **TAPE 2 MONITOR**.

To return to the previous source, press **TAPE 2 MONITOR** again so **TAPE 2** disappears.

#### Notes:

- If you press **TAPE 2 MONITOR** when that cassette deck is neither playing nor recording, the receiver mutes the current audio source. To hear the audio source, press **TAPE 2 MONITOR** until **TAPE 2** disappears from the display.
- Do not press **TAPE 2 MONITOR** while you are recording on the deck connected to **TAPE 2 REC**. If you do, the recording is interrupted for about 1 second.

### Recording a Program Source

The receiver sends the audio program source you select—**TAPE 1/VCR**, **TAPE 2 MONITOR**, **LD/DVD**, **CD**, **TUNER**, **PHONO**—to the **TAPE 1/VCR REC** and **TAPE 2 MONITOR REC** jacks. The **VOLUME** control does not affect the level of the signal going to the tape decks.

When you record a program source using the Tape 2 cassette deck, you hear the program source's signal immediately after you record it onto the tape, if the cassette deck you connected has a three-head monitor function. (Be sure to read the owner's manual for your cassette deck.)

### Simultaneous Recording and Playback

You can record any non-tape program source on the Tape 1 cassette deck while you listen to a cassette tape using **TAPE 2 MONITOR**.

Press the button for the desired program source (**LD/DVD**, **CD**, **TUNER**, **PHONO**), then press the record button on the cassette deck connected to **TAPE 1/VCR**. Tape 1 records the selected program source. Press **TAPE 2 MONITOR**, then start playback on the cassette deck connected to **TAPE 2 MONITOR**. **TAPE 2** appears and you hear Tape 2 play back while Tape 1 continues to record the program source you selected.



### **Dubbing a Cassette Tape**

You can copy, or dub, a cassette tape from one cassette deck to another.

You can use either deck as the playback or recording deck. However, if you want to monitor the cassette deck during dubbing, use the deck connected to the **TAPE 1/VCR** jacks as the source, and the deck you connected to the **TAPE 2 MONITOR** jacks as the recording deck. Then press **TAPE 2 MONITOR** until **TAPE 2** appears on the display. See "Using the TAPE 2 MONITOR Button" on the previous page.

# Using the Remote Control

The remote control works up to a distance of about 23 feet, and within a 30-degree angle on either side of the receiver. Point the control at the receiver's front panel and press the desired button(s).

Many buttons on the remote control work the same as buttons on the receiver's front panel. Use these buttons exactly as you would use the corresponding buttons on the receiver.

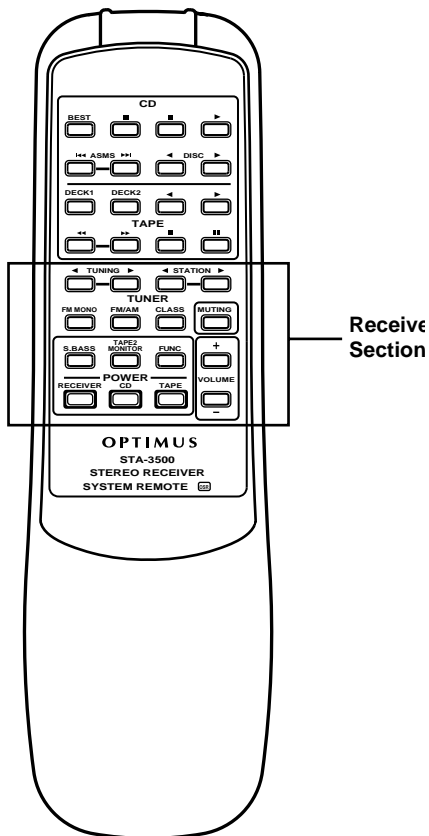

## Receiver/Amplifier Section

### FUNC

Selects a program source (Tape 1/VCR, LD/DVD, CD, tuner, or phono). Repeatedly press **FUNC** until the display shows your desired program source. See Page 13.

### - VOLUME +

Adjusts the system's volume. See Page 13.

### RECEIVER POWER

Turns the receiver on and off. See Page 13.

### TAPE 2 MONITOR

Switches the receiver to monitor the source connected to the **TAPE 2 MONITOR** jacks. See Page 16.

### S. BASS

Press to enhance bass sound.

### MUTING

Silences the receiver. Press again to restore the sound to its previous level. See Page 14.

### ◀ STATION ▶

Press to move the next higher or lower station in memory.

### CLASS

Press to select the class of the station in memory

### FM MONO

Press to disable the FM stereo mode to improve reception of weaker FM stations.

### ◀ TUNING ▶

**Manual Tuning:** Press once to select the next higher or lower frequency. Or, press and hold down to rapidly change frequencies.

**Automatic Tuning (FM Only):** To search for the next lower or higher station, release ◀ **TUNING** ▶ when the frequency starts to change. The receiver searches up or down the band until it finds a strong station.

### FM/AM

Press to switch between AM and FM bands.

## CD Player Section

**Note:** You must connect the CD player both to your receiver's **CONTROL OUT** and audio jacks for these functions to work.

**CD POWER** Turns the CD player on and off (only for CD players having the **CONTROL IN/OUT** feature).

|◀◀ ASMS ▶▶| Returns to the beginning of the current track or advances to the next track.

◀◀ DISC SELECT ▶▶ Selects discs in a multi-play CD changer.

**Note:** Some CD players might function with **DISC SELECT**.

▶ Plays the CD.

■ Stops playback.

▬ Press to temporarily stop play. Press again to resume.

**BEST** With a CD changer that has the BEST track memory function, such as an Optimus Professional Series CD-8200/8300/8400, press to select and play your favorite CD tracks.

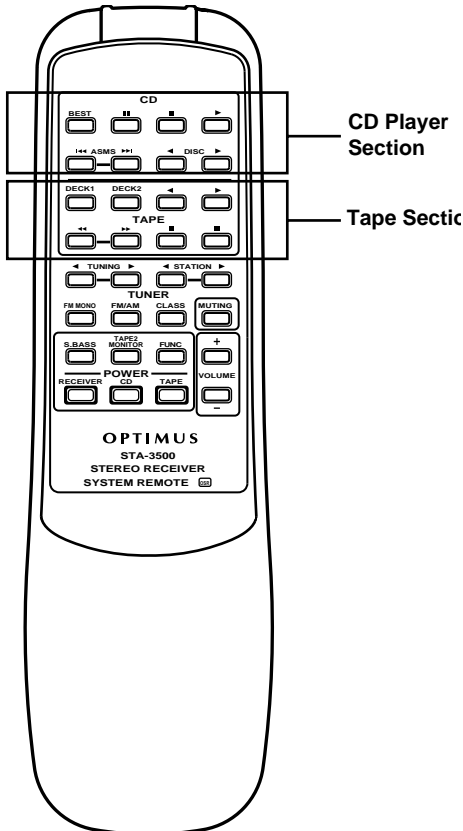

## Cassette Deck Section

Before operation, select **TAPE 2 MONITOR** or **TAPE1/VCR**.

**Note:** You must connect the cassette deck both to your receiver's **CONTROL OUT** and audio jacks for these functions to work.

▶ Press to start normal play.

◀ Press to play the reverse side of an auto-reverse cassette deck.

■ Press to cancel the current function.

▬ Press to temporarily stop playback/recording. Press again to resume.

◀◀ and ▶▶ Lets you quickly locate and play the beginning of recorded material during play.

When the tape is stopped, lets you rapidly search forward or backward to locate a specific section of the tape.

**DECK 1/DECK 2** Selects Deck 1 or Deck 2 when you use a dual cassette deck.

When you use a single cassette deck, press **DECK 2**.

**TAPE POWER** Turns the cassette deck on and off.

**Note:** **TAPE POWER** does not work with all Optimus Professional Series cassette decks.

# Troubleshooting

If the receiver is not working as it should, the following suggestions might help. If you follow the suggestions in this chart and the receiver still does not work properly, contact your local RadioShack store for assistance.

Problem	Cause	Solution
Power does not turn on.	<ul style="list-style-type: none"> <li>Power cord is disconnected.</li> </ul>	<ul style="list-style-type: none"> <li>Plug in the power cord.</li> </ul>
No sound.	<ul style="list-style-type: none"> <li>Incorrect connections.</li> <li>The mute function is activated.</li> <li>The volume is turned down.</li> <li>Speaker wires are disconnected.</li> <li>Neither set of speakers is selected.</li> <li>Both <b>SPEAKERS A</b> and <b>B</b> are pressed when only one set of speakers is connected.</li> <li><b>TAPE 2 MONITOR</b> is selected.</li> </ul>	<ul style="list-style-type: none"> <li>Check and correct the connections.</li> <li>Press <b>MUTING</b>.</li> <li>Turn up the volume.</li> <li>Connect the speaker wires.</li> <li>Press in <b>SPEAKERS A</b> or <b>B</b>.</li> <li>Press <b>SPEAKERS</b> button again for the terminals that have no speakers.</li> <li>Press <b>TAPE 2 MONITOR</b> again.</li> </ul>
Sound is produced from only one speaker.	<ul style="list-style-type: none"> <li>One of the speaker wires or input cord is disconnected.</li> <li><b>BALANCE</b> is set too far to one side.</li> </ul>	<ul style="list-style-type: none"> <li>Check all connections.</li> <li>Set <b>BALANCE</b> to the center position.</li> </ul>
High noise level.	<ul style="list-style-type: none"> <li>Station not correctly tuned.</li> <li>Antenna not connected.</li> <li>FM antenna still coiled or is not pointing in the correct direction.</li> <li>AM loop antenna not pointing in the correct direction.</li> <li>Noise is coming from another electrical appliance.</li> </ul>	<ul style="list-style-type: none"> <li>Tune to a stronger station.</li> <li>Connect the antenna.</li> <li>Stretch both ends of the antenna taut and reposition the antenna.</li> <li>Adjust the AM loop antenna.</li> <li>Try using an AC line noise filter to reduce the noise.</li> </ul>
Tuning does not automatically stop when searching for FM stations.	<ul style="list-style-type: none"> <li>Stations are too weak.</li> </ul>	<ul style="list-style-type: none"> <li>Use a better antenna.</li> </ul>
Remote control does not work.	<ul style="list-style-type: none"> <li>Batteries are dead or missing.</li> <li>Poor angle or too great a distance from the remote sensor window.</li> <li>There is an obstacle between you and the remote sensor window.</li> <li>For CD players and cassette decks, the remote control cord is not connected.</li> <li>A fluorescent light is shining on the remote sensor window.</li> </ul>	<ul style="list-style-type: none"> <li>Install fresh batteries.</li> <li>Use within 23 feet and within a 30-degree angle of the remote sensor window.</li> <li>Change your position or remove the obstacle.</li> <li>Connect the remote control cord.</li> <li>Turn off the light.</li> </ul>
Remote does not control cassette deck or CD player.	<ul style="list-style-type: none"> <li>Cassette deck or CD changer not compatible.</li> <li>Control cable is not plugged in.</li> <li>Audio cables are not plugged in.</li> </ul>	<ul style="list-style-type: none"> <li>The feature only works with Optimus Professional Series components.</li> <li>Properly connect the control cable.</li> <li>Properly connect the audio cables.</li> </ul>

# Care and Maintenance

Your STA-3500 Digital Synthesized AM/FM Stereo Receiver is an example of superior design and craftsmanship. The following suggestions will help you care for the receiver so you can enjoy it for years.



Keep the receiver dry. If it gets wet, wipe it dry immediately. Liquids can contain minerals that can corrode the electronic circuits.



Handle the receiver gently and carefully. Dropping it can damage its circuit boards and can cause the receiver to work improperly.



Use and store the receiver only in normal temperature environments. Temperature extremes can shorten the life of electronic devices, damage batteries, and distort or melt plastic parts.



Keep the receiver away from dust and dirt, which can cause premature wear of parts.



Wipe the receiver with a damp cloth occasionally to keep it looking new. Do not use harsh chemicals, cleaning solvents, or strong detergents to clean the receiver.



Use only fresh batteries of the recommended size and type in the remote control. Always remove old or weak batteries. They can leak chemicals that can destroy electronic circuits.

Modifying or tampering with your receiver's internal components can cause a malfunction and might invalidate the receiver's warranty and void your FCC authorization to operate it. If the receiver is not operating as it should, take it to your local RadioShack store for assistance.

# The FCC Wants You To Know

Your receiver might cause radio or TV interference even when it is operating properly. To determine whether your receiver is causing the interference, turn off your receiver. If the interference goes away, your receiver is causing it. Try to eliminate the interference by:

- Moving your radio or TV away from the receiver
- Connecting your receiver to an outlet that is on a different electrical circuit from the radio or TV
- Contacting your local RadioShack store for help

If you cannot eliminate the interference, the FCC requires that you stop using your receiver.

# Specifications

## Amplifier

Front Channel Average Power Output	100 Watts per Channel into 8 Ohms From 40 to 20,000 Hz, With No More than 0.9% Total Harmonic Distortion Measured Pursuant to the Federal Trade Commission's Trade Regulation Rule on Amplifier Output Power Claims
Input Sensitivity/Impedance	
Phono	2.8 mV/47 kOhms
CD, LD/DVD, TAPE 1/VCR, Tape 2 Monitor	200 mV/47 kOhms
Phono Overload Level (0.1% THD, 1 kHz)	100 mV
Frequency Response	
Phono	20 Hz to 20,000 Hz $\pm$ 0.5 dB
CD, LD/DVD, TAPE 1/VCR, TAPE 2 Monitor	5 Hz to 100,000 Hz +0/-3.0 dB
Signal-to-Noise Ratio (IHF, Short Circuited, A Network)	
Phono	72 dB
CD, LD/DVD, TAPE 1/VCR, Tape 2 Monitor	96 dB
Signal-to-Noise Ratio (EIA, at 1 Watt, 1 kHz)	
Phono	77 dB
CD, LD/DVD, TAPE 1/VCR, Tape 2 Monitor	80 dB

---

## FM Tuner

Frequency Range	87.5 to 108 MHz
Usable Sensitivity	Mono: 11.2 dBf, IHF (1.0 $\mu$ V/75 Ohms)
50 dB Quieting Sensitivity	
Mono	16.8 dBf (1.9 $\mu$ V/75 Ohms)
Stereo	38.6 dBf (23.3 $\mu$ V/75 Ohms)
Signal-to-Noise Ratio	
Mono	76 dB (at 85 dBf)
Stereo	72 dB (at 85 dBf)
Distortion Stereo	0.5% (1 kHz)
Alternate Channel Selectivity	60 dB (400 kHz)
Stereo Separation	40 dB (1 kHz)
Frequency Response	30 Hz to 15 kHz ( $\pm$ 1 dB)
Antenna Input	75 Ohms Unbalanced

---

## AM Tuner

Frequency Range	530 to 1700 kHz
Sensitivity (IHF, Loop Antenna)	350 $\mu$ V/m
Selectivity	25 dB
Signal-to-Noise Ratio	50 dB

## General

Power Requirements .....	120 Volts AC, 60 Hz
Power Consumption .....	190 Watts (UL)
AC Outlet Ratings Switched .....	100 Watts (0.8 Amps) Maximum
Dimensions (HWD) .....	5 1/2 × 16 9/16 × 11 3/4 Inches (140 × 420 × 298mm)
Weight .....	14 lbs, 6oz (6.6 kg)

Specifications are typical; individual units might vary. Specifications are subject to change and improvement without notice.



# Index to Features by Control Name

This table lists the control and indicator names found on the front of your receiver, along with the page number where the control or indicator is discussed. To find a description for the buttons on the remote control, see "Using the Remote Control" on Page 18.

<b>Control</b>	<b>Page</b>
BALANCE	15
BASS	13
CD	13
CLASS	14
FM MONO	15
FM/AM	14
LD/DVD	13
MEMORY	14
MUTING	16
PHONES	16
PHONO	13
POWER	13
SPEAKERS A and B	13
STATION	14
STANDBY	12
SUPER BASS	13
TAPE 1/VCR	13, 16
TAPE 2 MONITOR	13, 16
TREBLE	13
TUNER	13
TUNING	14
VOLUME	13





### **RadioShack Limited Warranty**

This product is warranted against defects for 2 years from date of purchase from RadioShack company-owned stores and authorized RadioShack franchisees and dealers. Within this period, we will repair it without charge for parts and labor. Simply **bring your RadioShack sales slip** as proof of purchase date to any RadioShack store. Warranty does not cover transportation costs. Nor does it cover a product subjected to misuse or accidental damage.

EXCEPT AS PROVIDED HEREIN, RADIOSHACK MAKES NO EXPRESS WARRANTIES AND ANY IMPLIED WARRANTIES ARE LIMITED IN DURATION TO THE DURATION OF THE WRITTEN LIMITED WARRANTIES CONTAINED HEREIN. Some states do not permit limitation or exclusion of implied warranties; therefore, the aforesaid limitation(s) or exclusion(s) may not apply to the purchaser.

This warranty gives you specific legal rights and you may also have other rights which vary from state to state.

*We Service What We Sell*

10/95

**RadioShack**  
**A Division of Tandy Corporation**  
**Fort Worth, Texas 76102**

## Free Manuals Download Website

<http://myh66.com>

<http://usermanuals.us>

<http://www.somanuals.com>

<http://www.4manuals.cc>

<http://www.manual-lib.com>

<http://www.404manual.com>

<http://www.luxmanual.com>

<http://aubethermostatmanual.com>

Golf course search by state

<http://golfingnear.com>

Email search by domain

<http://emailbydomain.com>

Auto manuals search

<http://auto.somanuals.com>

TV manuals search

<http://tv.somanuals.com>