

**This manual contains important warnings and information.  
READ AND KEEP FOR REFERENCE.**

INSTRUCTIONS

*First choice when quality counts.™*

## ULTRA® MAX 695 Airless Paint Sprayer

3000 psi (210 bar, 21 MPa) Maximum Working Pressure

**230 VAC** 

**232918, A**

Hi-boy sprayer with hoses, gun, RAC IV® DripLess™ Tip Guard and SwitchTip™

**240 VAC**

**232914, A**

Hi-boy sprayer with hoses, gun, RAC IV® DripLess™ Tip Guard and SwitchTip™

**232915, A**

Lo-boy sprayer with hoses, gun, RAC IV® DripLess™ Tip Guard and SwitchTip™

**120 VAC** 

**232919, A**

Hi-boy sprayer with hoses, gun, RAC IV® DripLess™ Tip Guard and SwitchTip™

**120 VAC**

**232910 – 232913, A**

232911 Hi-boy & 232913 Lo-boy sprayers with hoses, gun, RAC IV® DripLess™ Tip Guard and SwitchTip™

232910 Hi-boy & 232912 Lo-boy sprayers

**100 VAC**

**232916, A; 232917, A**

Basic Hi-boy sprayer; Basic Lo-boy sprayer

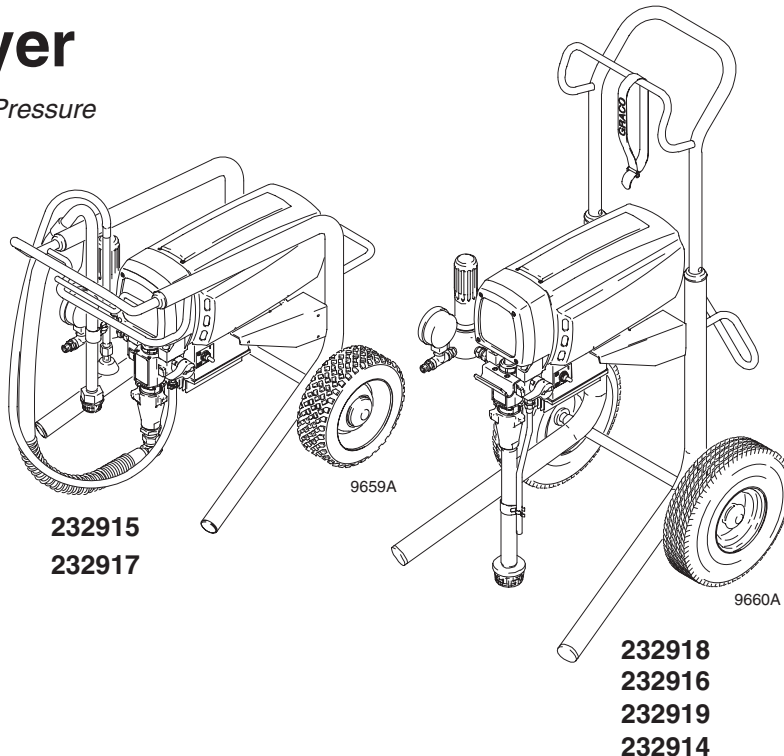

### Related Manuals

Operation .....	309067
Displacement Pump .....	308815
Fluid Filter .....	308249
Spray Gun .....	309091
Spray Tip .....	309055

## Table of Contents

Component Function and Identification .....	2	Drive Housing, Connecting Rod, Crankshaft .....	15
General Repair Information .....	3	Pressure Transducer .....	16
Grounding .....	4	Pressure Transducer Seal .....	16
Troubleshooting .....	4	Drain Valve .....	18
Motor Test .....	9	Technical Data .....	19
Motor Brushes .....	10	Dimensions .....	19
Displacement Pump .....	11	Accessories .....	19
Motor .....	12	Complete Sprayer Parts .....	20
Motor Control Board .....	14	Graco Warranty .....	28
Power Cord .....	14	Phone Number .....	28
On/Off Switch .....	14		
Pressure Adjusting Potentiometer .....	14		

**GRACO INC. P.O. BOX 1441 MINNEAPOLIS, MN 55440-1441**

©COPYRIGHT 1999, GRACO INC.

Graco Inc. is registered to I.S. EN ISO 9001

# Component Function and Identification

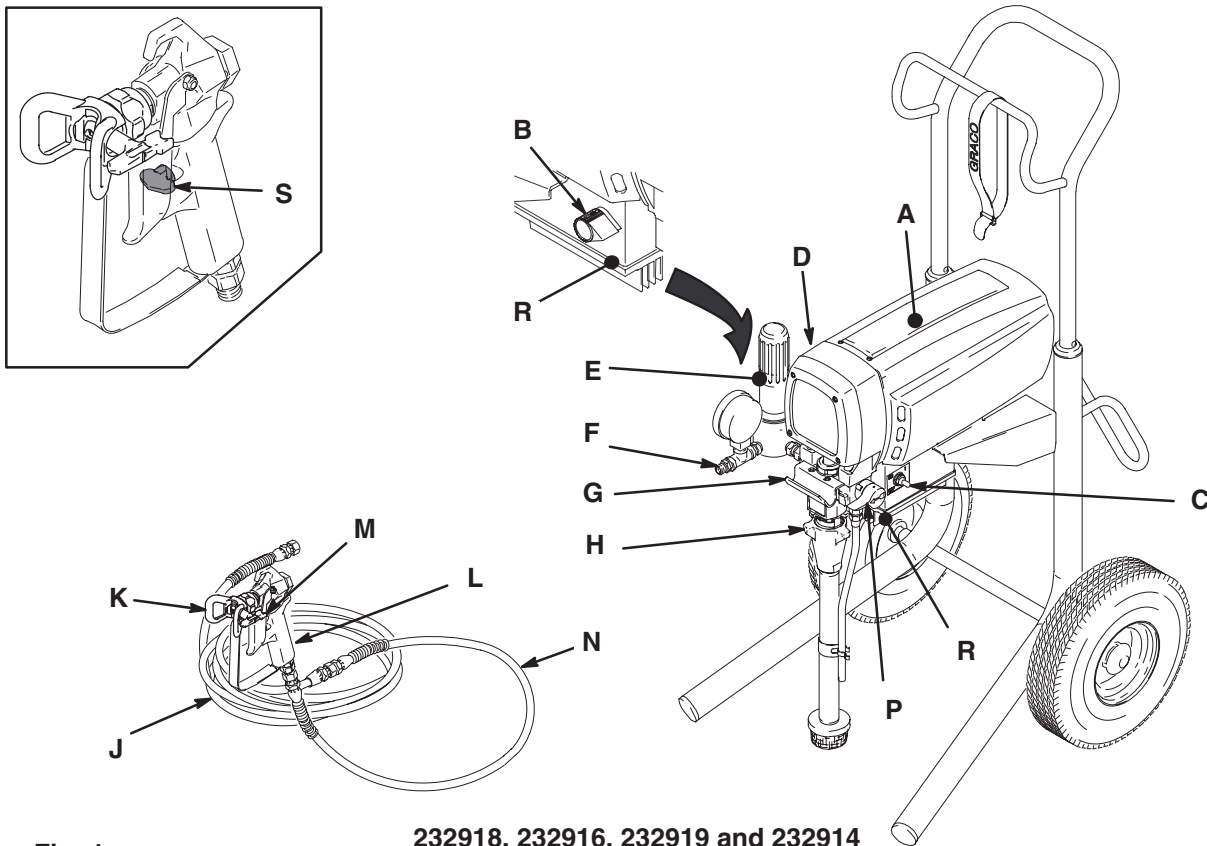

Fig. 1

232918, 232916, 232919 and 232914

9661A

<b>A</b>	Motor (Under shield shown)	DC motor, permanent magnet, totally enclosed, fan cooled
<b>B</b>	Pressure Adjusting Knob	Controls fluid outlet pressure
<b>C</b>	ON/OFF Switch	Power switch that controls VAC main power to sprayer
<b>D</b>	Drive Assembly	Transfers power from DC motor to the displacement pump
<b>E</b>	Fluid Filter	Filter of fluid between source and spray gun
<b>F</b>	Fluid Outlet	Main hose to spray gun is connected here
<b>G</b>	Pail Hanger	Container for fluid to be sprayed may be hung here
<b>H</b>	Displacement Pump	Transfers fluid to be sprayed from source through spray gun
<b>J</b>	50 ft (15 m) Main Hose	1/4 in. ID, grounded, nylon hose with spring guards on both ends
<b>K</b>	RAC IV Tip Guard	Reverse-A-Clean (RAC) tip guard reduces the risk of fluid injection injury
<b>L</b>	Contractor Gun	High pressure spray gun with gun safety latch
<b>M</b>	RAC IV Switch Tip	RAC switch tip uses high pressure fluid to remove clogs from spray tip without removing tip from spray gun
<b>N</b>	3 ft (0.9 m) Hose	3/16 in. ID, grounded, nylon hose used between 50 ft hose and spray gun to allow more flexibility when spraying
<b>P</b>	Pressure Drain Valve	Relieves fluid outlet pressure when open; diverts fluid to drain line
<b>R</b>	Pressure Control	Controls motor speed to maintain fluid outlet pressure at displacement pump outlet. Works with pressure adjusting knob.
<b>S</b>	Spray Gun Safety Latch	Inhibits accidental triggering of spray gun

# General Repair Information

## CAUTION

To reduce risk of pressure control malfunction:

- Use needle nose pliers to disconnect a wire. Never pull on wire, pull on connector.
- Mate wire connectors properly. Center flat blade of insulated male connector in female connector.
- Route wires carefully to avoid interference with other connections of pressure control. Do not pinch wires between cover and control box.

### Tool List

Phillips screwdriver	1/4 in. hex key wrench
Small flat blade screwdriver	3/16 in. hex key wrench
Needle nose pliers	5/8 in. socket wrench
Plastic mallet or 20 oz (max) hammer	3/8 in. open end wrench
12 in. adjustable wrench	1/2 in. open end wrench
Adjustable, open-end wrench	3/4 in. open end wrench
Torque wrench	7/8 in. open end wrench
	High quality motor oil
	Bearing grease

1. **Keep all screws, nuts, washers, gaskets, and electrical fittings** removed during repair procedures. These parts are not normally provided with replacement assemblies.

## WARNING



### ELECTRIC SHOCK HAZARD

To reduce risk of serious injury, including electric shock, do not touch moving or electrical parts with fingers or tools while testing repair. Shut off and unplug sprayer when inspection is complete. Install all covers, gaskets, screws and washers before operating sprayer.

2. **Test repair** after problem is corrected.
3. **If sprayer does not operate properly**, review repair procedure to verify procedure was done correctly. If necessary, see Troubleshooting, page 4, for other possible solutions.

## WARNING



### EXPLOSION HAZARD

Motor and drive housing are very hot during operation and could burn skin if touched. Flammable materials spilled on hot, bare motor could cause fire or explosion. Have motor shield in place during operation to reduce risk of burns, fire or explosion.

## CAUTION

Do not run sprayer dry for more than 30 seconds to avoid damaging pump packings.

4. **Install motor shield before operation** of sprayer and replace if damaged. Motor shield directs cooling air around motor to prevent overheating. It can also reduce risk of burns, fire or explosion; see preceding **WARNING**.

### Pressure Relief Procedure

## WARNING



### INJECTION HAZARD

System pressure must be manually relieved to prevent system from starting or spraying accidentally. Fluid under high pressure can be injected through skin and cause serious injury. To reduce risk of injury from injection, splashing fluid, or moving parts, follow **Pressure Relief Procedure** whenever you:

- are instructed to relieve pressure,
- stop spraying,
- check or service any system equipment,
- or install or clean spray tip.

1. Lock gun safety latch.
2. Turn ON/OFF switch to OFF.
3. Unplug power cord.
4. Unlock gun safety latch. Hold metal part of gun firmly to grounded metal pail. Trigger gun to relieve pressure.
5. Lock gun safety latch.
6. Open pressure drain valve. Leave pressure drain valve open until ready to spray again.

*If suspected that spray tip or hose is completely clogged, or that pressure has not been fully relieved after following steps above, VERY SLOWLY loosen tip guard retaining nut or hose end coupling to relieve pressure gradually, then loosen completely. Now clear tip or hose obstruction.*

# Grounding

## ⚠ WARNING

Improper installation or alteration of grounding plug results in risk of electric shock, fire or explosion that could cause serious injury or death.

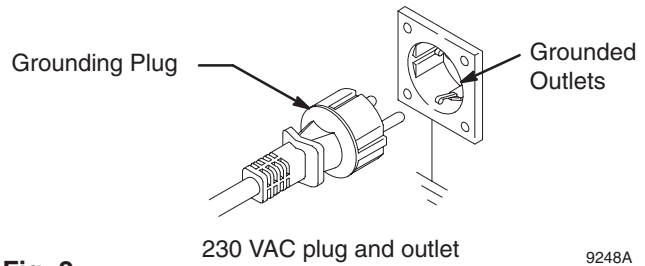

Fig. 2

230 VAC plug and outlet

9248A

- The 232918, 232915, 232914 require a 230 VAC, 50 Hz, 10A circuit with a grounding receptacle. The 232919 requires a 120 VAC, 50/60 Hz, 15A circuit with a grounding receptacle. The 232916, 232917 require a 100 VAC, 50 Hz, 15A circuit with a grounding receptacle. The 232910 – 232913 require 120 VAC, 60 HZ, 15A with a grounding receptacle. See Fig. 2.
- Do not alter ground prong or use adapter.
- A 12 AWG, 3 wires with grounding prong, 300 ft (90 m) extension cord may be used. Long lengths reduce sprayer performance.

# Troubleshooting



Relieve pressure; page 3.

## Basic Problem Solving

TYPE OF PROBLEM	WHAT TO CHECK <i>If check is OK, go to next check</i>	WHAT TO DO <i>When check is not OK, refer to this column</i>
Fluid Pressure	1. Pressure control knob setting. Motor will not run if at minimum setting (fully counterclockwise).	1. Slowly increase pressure setting to see if motor starts.
	2. Clogged spray tip or fluid filter, if used. Refer to separate gun, tip or fluid filter instruction manual.	2. If tip is still clogged, relieve pressure; refer to separate gun or tip instruction manual for tip cleaning. Clean or replace filter element. See manual 308249.
Mechanical	1. Frozen or hardened paint in pump (18). Use a screwdriver and carefully rotate fan at back of motor. See page 12.	1. Thaw sprayer if water or water-based paint has frozen in sprayer. Place sprayer in warm area to thaw. Do not start sprayer until completely thawed. If paint hardened (dried) in sprayer the pump packings and/or pressure transducer must be replaced. See page 11 (pump) or 16 (pressure transducer).
	2. Pump connecting rod pin (14). Pin must be completely pushed into connecting rod (12), and retaining spring (15) must be firmly in connecting rod groove. See Fig. 9, page 11.	2. Push pin into place and secure with spring retainer.
	3. For motor damage. Remove drive housing assembly (2). See page 15. Try to rotate motor fan by hand.	3. Replace motor (85) if fan won't turn. See page 12.
Electrical	1. Electrical supply with volt meter. Meter must read 90–110 VAC for 232916, 232917. Meter must read 105–125 VAC for 232910 – 232913, 232919. Meter must read 210–250 VAC for 232918, 232915, 232914.	1. Reset building circuit breaker; replace building fuse. Try another outlet.
	2. Extension cord for damage. Check extension cord continuity with volt meter.	2. Replace extension cord.
	3. Sprayer power cord (30) for damage such as broken insulation or wires.	3. Replace power cord. See page 14.

# Basic Problem Solving

TYPE OF PROBLEM	WHAT TO CHECK <i>If check is OK, go to next check</i>	WHAT TO DO <i>When check is not OK, refer to this column</i>
Electrical <i>(continued)</i>	<p>4. Motor brushes for the following:</p> <ul style="list-style-type: none"> <li>a. Loose terminal screws.</li> <li>b. Broken or misaligned brush springs.</li> <li>c. Brushes binding in holders.</li> <li>d. Broken leads.</li> <li>e. Worn brushes.</li> <li>f. Brush leads snagged on spring clip.</li> </ul> <p><b>NOTE:</b> Brushes do not wear at same rate on both sides of motor. Check both brushes.</p>	<p>4. Refer to page 10.</p> <ul style="list-style-type: none"> <li>a. Tighten.</li> <li>b. Replace broken spring and/or align spring with brush</li> <li>c. Clean brush holders. Remove carbon with small cleaning brush. Align brush leads with slot in brush holder to assure free vertical brush movement.</li> <li>d. Replace brushes</li> <li>e. Replace brushes if less than 0.5 in. (12.5 mm) long.</li> <li>f. Correctly route wires. See page 10.</li> </ul>
	<p>5. Motor armature commutator for burn spots, gouges and extreme roughness. Remove motor cover and brush inspection plates to check. See page 10.</p>	<p>5. Remove motor and have motor shop resurface commutator if possible. See page 12.</p>
	<p>6. Motor armature for shorts using armature tester (growler) or perform motor test. See page 9.</p>	<p>6. Replace motor. See page 12.</p>
	<p>7. That leads from pressure transducer and motor to motor control board (22a) are securely fastened and properly mated.</p>	<p>7. Replace loose terminals; crimp to leads. Be sure male terminal blades are straight and firmly connected to mating part.</p>
	<p>8. Motor control board (22a) by performing motor control board diagnostics on page 13. If diagnostics indicate, substitute with a good board.</p> <p><b>CAUTION:</b> Do not perform this check until motor armature is determined to be good. A bad motor armature can burn out a good board.</p>	<p>8. Replace board. See page 13.</p>
	<p>9. Power cord (30). 232918, 232915, 232914. Disconnect brown and blue power cord terminals; connect volt meter to these leads. Plug in sprayer. Meter must read 210–250 VAC. 232910 – 232913, 232919. Disconnect brown and blue power cord terminals; connect volt meter to these leads. Plug in sprayer. Meter must read 105–125 VAC. 232916, 232917. Disconnect black and white power cord terminals; connect volt meter to these leads. Plug in sprayer. Meter must read 90–110 VAC. Unplug sprayer.</p>	<p>9. Replace power cord. See page 14.</p>
	<p>10. ON/OFF switch (80). 232918, 232915, 232914. Disconnect brown wire (96) between motor control board (22a) and switch and connect volt meter between exposed terminal switch and power cord blue wire (94). Plug in sprayer and turn <b>ON</b>. Meter must read 210–250 VAC. 232910 – 232913, 232919. Disconnect brown wire (96) between motor control board (22a) and switch and connect volt meter between exposed terminal switch and power cord blue wire (94). Plug in sprayer and turn <b>ON</b>. Meter must read 105–125 VAC. 232916, 232917. Disconnect black wire (96) between motor control board (22a) and switch and connect volt meter between exposed terminal of (96) and power cord white wire. Plug in sprayer and turn <b>ON</b>. Meter must read 90–110 VAC. Turn <b>OFF</b> and unplug sprayer.</p>	<p>10. Replace ON/OFF switch. See page 14.</p>

# Basic Problem Solving

TYPE OF PROBLEM	WHAT TO CHECK <i>If check is OK, go to next check</i>	WHAT TO DO <i>When check is not OK, refer to this column</i>
	11. Motor thermal cutout switch. Connect ohmmeter between motor yellow leads. Meter must read 1 ohm maximum.	11. Allow motor to cool. Correct cause of overheating. If switch remains open after motor cools, replace motor.
	12. Pressure transducer (67) by replacing it with a new one.	12. Replace pressure transducer. See page 16.
	13. Pressure adjustment potentiometer (77) by replacing it with a new one.	13. Replace potentiometer. See page 14.

# Intermediate Problem Solving

TYPE OF PROBLEM	WHAT TO CHECK <i>If check is OK, go to next check</i>	WHAT TO DO <i>When check is not OK refer to this column</i>
Low output	1. For worn spray tip.	1. Follow <b>Pressure Relief Procedure Warning</b> on page 3, then replace tip. See your separate gun or tip manual.
	2. Verify pump does not continue to stroke when gun trigger is released. Plug in and turn on sprayer. Prime with paint. Trigger gun momentarily, then release and engage safety latch. Relieve pressure, turn off and unplug sprayer.	2. Service pump. See page 11.
	3. Release gun trigger. Observe resting position of pump rod (222).	3. If pump consistently comes to rest with rod (222) fully extended, the piston packings and/or piston valve may be worn. Service pump. See page 11.
	4. Electrical supply with volt meter. Meter must read 90–110 VAC for 232916, 232917. Meter must read 105–125 VAC for 232910 – 232913, 232919 Meter must read 210–250 VAC for 232918, 232915, 232914.	4. Reset building circuit breaker; replace building fuse. Repair electrical outlet or try another outlet.
	5. Extension cord size and length; must be at least 12 AWG (1.5 mm <sup>2</sup> ) and no longer than 300 ft (90 m).	5. Replace with a correct, grounded extension cord.
	6. Motor brushes. See Electrical – What To Check, item 4, on page 5.	6. See page 10.
Low output <i>(continued)</i>	7. Motor control board (22a) by substituting with a good board.  <b>CAUTION:</b> Do not perform this check until motor armature is determined to be good. A bad motor armature can burn out a good board.	7. Replace board. See page 13.
	8. Motor armature for shorts by using an armature tester (growler) or perform motor test. See page 9.	8. Replace motor. See page 12

# Intermediate Problem Solving

TYPE OF PROBLEM	WHAT TO CHECK <i>If check is OK, go to next check</i>	WHAT TO DO <i>When check is not OK, refer to this column</i>
Drain valve leaks	1. Drain valve for correct torque and/or worn parts. Check for debris trapped on seat.	1. Tighten to 185 in-lb (21 N-m). Clean valve and replace with new gasket (55) and sealant 110–110. See page 18.
No output: motor runs and pump strokes	1. Paint supply.	1. Refill and reprime pump.
	2. For clogged intake strainer.	2. Remove and clean, then reinstall.
	3. For loose suction tube or fittings.	3. Tighten; use thread sealant on npt threads of adapter fitting (43).
	4. To see if intake valve ball and piston ball are seating properly. See page 11.	4. Remove intake valve and clean. Check ball and seat for nicks; replace as needed. See page 11. Strain paint before using to remove particles that could clog pump.
	5. For leaking around throat packing nut which may indicate worn or damaged packings. See page 11.	5. Replace packings. See page 11. Also check piston valve seat for hardened paint or nicks and replace if necessary. Tighten packing nut.
	6. Release gun trigger. Observe resting position of pump rod (222).	6. If pump consistently comes to rest with rod (222) fully extended, piston packings and/or piston valve may be worn. Service pump. See page 11.
No output: motor runs but pump does not stroke	1. Displacement pump connecting rod pin (14). See Fig. 9, page 11.	1. Replace pin if missing. Be sure retainer spring (15) is fully in groove all around connecting rod.
	2. Connecting rod assembly (12) for damage. See page 15.	2. Replace connecting rod assembly. See page 15.
	3. Be sure crank in drive housing rotates; plug in sprayer and turn on briefly to check. Turn off and unplug sprayer. See page 15.	3. Check drive housing assembly for damage and replace if necessary. See page 15.
Spray pattern variations	1. Spray tip worn beyond sprayer pressure capability.	1. Replace spray tip. <b>NOTE:</b> Smaller size tip provides longer life.
	2. Motor control board (22a) by performing motor control board diagnostics on page 13. If diagnostics indicate, substitute with a good board.  <b>CAUTION:</b> Do not perform this check until motor armature is determined to be good. A bad motor armature can burn out a good board.	2. Replace board. See page 13.

# Intermediate Problem Solving

TYPE OF PROBLEM	WHAT TO CHECK <i>If check is OK, go to next check</i>	WHAT TO DO <i>When check is not OK, refer to this column</i>
Spray pattern variations <i>(continued)</i>	3. Pressure adjustment potentiometer (77) by replacing with a new one. 4. Low Output section, page 6.	3. Replace potentiometer. See page 14..
Motor is hot and runs intermittently	1. Determine if sprayer was operated at high pressure with small tips, which causes excessive heat build up. 2. Be sure ambient temperature where sprayer is located is no more than 90°F (32°C) and sprayer is not located in direct sun. 3. Motor.	1. Decrease pressure setting or increase tip size. 2. Move sprayer to shaded, cooler area if possible. 3. Replace motor. See page 12.
Building circuit breaker opens as soon as sprayer switch is turned on.	1. All electrical wiring for damaged insulation, and all terminals for loose fit or damage. Also check wires between pressure transducer and motor. See page 12. 2. For missing motor brush inspection plate gasket (see page 10), bent terminal forks or other metal to metal contact points which could cause a short. 3. Motor armature for shorts. Use an armature tester (growler) or perform motor test. See page 9. Inspect windings for burns. 4. Motor control board (22a) by performing motor control board diagnostics on page 13. If diagnostics indicate, substitute with a good board.  <b>CAUTION:</b> Do not perform this check until motor armature is determined to be good. A bad motor armature can burn out a good board	1. Repair or replace any damaged wiring or terminals. Securely reconnect all wires. 2. Correct faulty conditions. 3. Replace motor. See page 12. 4. Replace board. See page 13.
Circuit breaker opens after sprayer operates for 5 to 10 minutes.	1. Basic Problems – Electrical' on page 4.	
Building circuit breaker opens as soon as sprayer is plugged into outlet and sprayer is not turned on.	1. ON/OFF switch (80). Be sure sprayer is unplugged! Disconnect wires from switch. Check switch with ohmmeter. The reading should be infinity with ON/OFF switch OFF, and zero with switch ON.  <b>CAUTION:</b> A short in motor circuit can damage switch and or motor control board (22a). 2. For damaged or pinched wires in junction box (20).	1. Replace ON/OFF switch. See page 14. 2. Replace damaged parts.
Unit will not run on generator but does run on AC power	1. Generator "peak" voltage. Sprayer will not run if peak voltage is above 165 or below 75 VAC for 232916, 232917; above 190V or below 100V for 232910 – 232913, 232919 or above 260V or below 180V for 232918, 232915, 232914.	1. Use AC power or a different generator.





# Motor Brushes

**NOTE:** Replace brushes worn to less than 13 mm (0.5 in.). Check both brushes. Use Brush Repair Kit 236967 (243268 for sprayers 232914 and 232915) for motor brush repair.



Relieve pressure; page 3.

1. Unplug sprayer.
2. Remove both inspection covers (A) and their gaskets. See Fig.5.

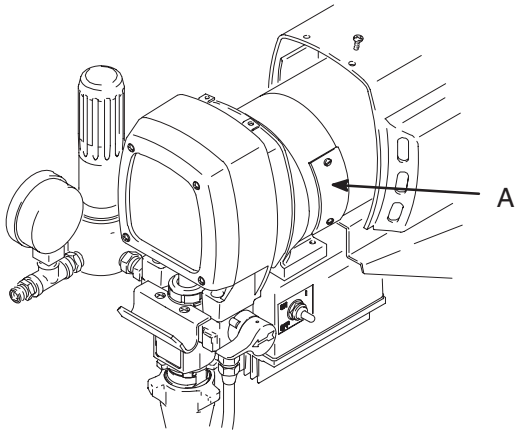

Fig. 5 9662A

3. Push in spring clip (F) and release hooks (G) from brush holder (B). Pull out spring clip. See Fig. 6.
4. Inspect commutator for excessive pitting, burning or gouging. A black color on commutator is normal. Have commutator resurfaced by a qualified motor repair shop if brushes seem to wear too fast or arc excessively. See Step 9.d., also.
5. Repeat for other side.
6. Place a new brush (C) in holder (B) so ramp (H) faces spring. See Fig. 6.
7. Holding spring clip (F) at a slight angle, slide spring clip into brush holder and hook it over end of holder. See Fig. 7. Pull on spring clip to be sure it stays in place. Connect brush lead to blade connector (E).
8. Repeat for other side.
9. **Test brushes.**
  - a. Remove pump connecting rod pin (14).

**⚠ WARNING**

**ELECTRIC SHOCK HAZARD**  
Do not touch the brushes, leads, springs or brush holders while the sprayer is plugged in to reduce the risk of electric shock and serious bodily injury.

- b. With sprayer OFF, turn pressure control knob fully counterclockwise to minimum pressure. Plug in sprayer.
  - c. Turn sprayer ON. Slowly increase pressure until motor is at full speed.
  - d. Inspect brush and commutator contact area for excessive arcing. Arcs must not trail or circle around commutator surface.
10. Install brush inspection covers and gaskets.
  11. Install pump connecting rod pin (14).

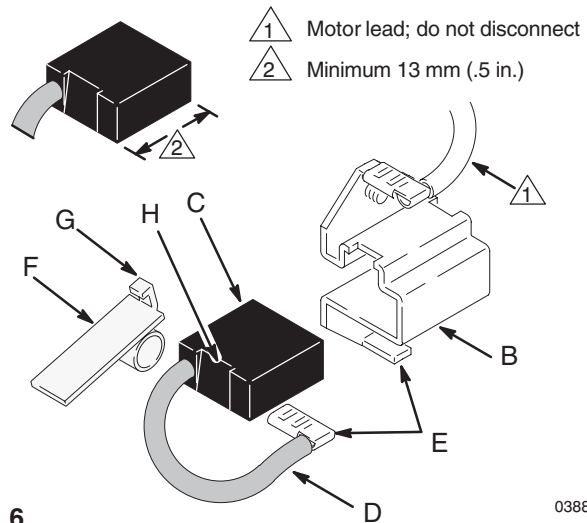

Fig. 6 03881

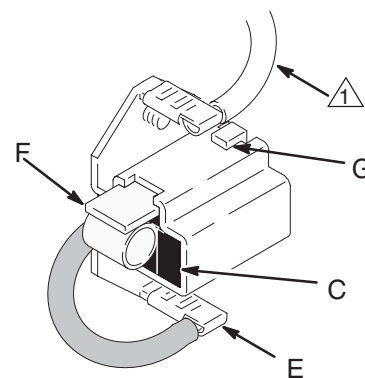
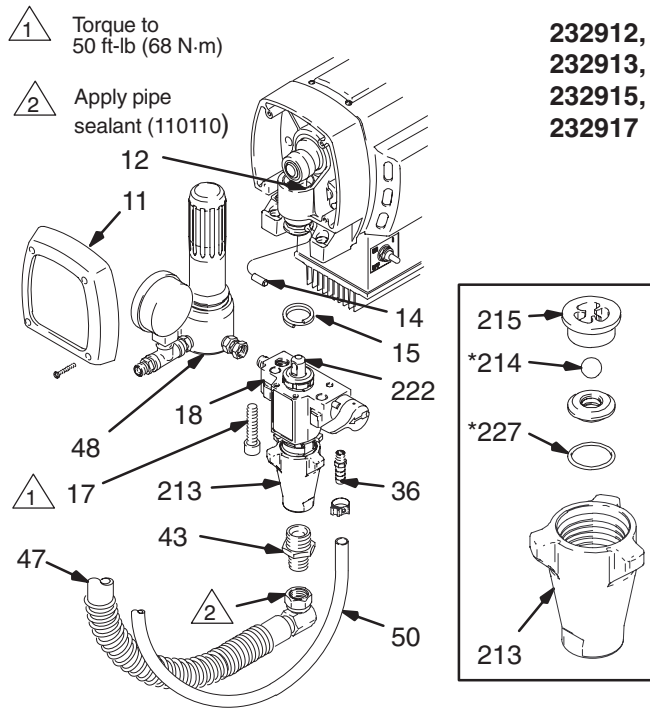

Fig. 7 03881

# Displacement Pump

**NOTE:** Packing Repair Kit 239939 is available. Reference numbers of parts included in the kit are marked with an asterisk, i.e., (223\*).

## Removing pump (See Fig.8)



**Fig. 8** 9663A

1.  Relieve pressure; page 3.
2. Flush pump, if possible. Relieve pressure. Stop pump with piston rod (222) in its lowest position, if possible. To lower piston rod manually, rotate motor fan blades.
3. Remove filter (48).
4. **232912, 232913, 232915, 232917.** Unscrew drain hose from inlet adapter (43). Remove drain hose by unscrewing displacement pump nipple (36).
5. **232910, 232911, 232914, 232916, 232918 and 232919.** Remove suction tube. Remove drain hose by unscrewing displacement pump nipple (36).
6. Use a screwdriver to push retaining spring (15) up and push out pin (14).

7. Loosen screws (17). Remove pump (18).

## Repairing pump

See manual 308815 for displacement pump repair instructions and parts.

## Installing pump (See Fig. 8 and 9)

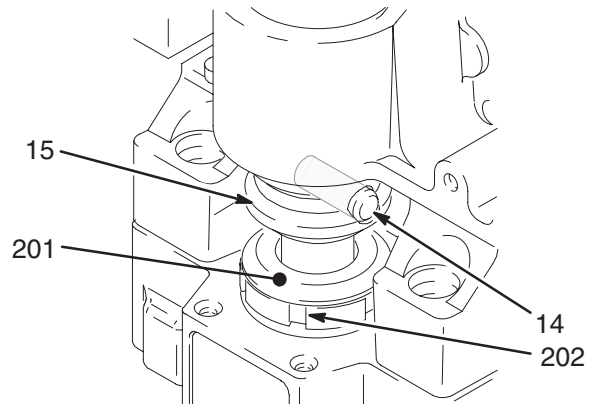

**Fig. 9** 7840A

1. Lightly grease or oil transducer (67). See Fig. 15. Guide pump over alignment pins and pressure transducer. Tap it into position with a soft hammer. Tighten screws (17) to 50 ft-lb (68 N-m).
  2. Align hole in rod (222) with connecting rod assembly (12). Use screwdriver to push retaining spring (15) up and push in pin (14). Push retaining spring into place around connecting rod.
- ⚠ WARNING**

**MOVING PARTS HAZARD**  
Be sure retaining spring (18) is firmly in groove all around, to prevent pin (14) from working loose. See Fig. 9.

If pin works loose, parts (including pump connecting rod or bearing housing) could project into the air and cause serious injury or property damage.
3. Reconnect suction and drain hoses (47, 50). Install front cover (11).
  4. Tighten packing nut (202) enough to stop leakage, but no tighter. Fill packing nut full with Graco TSL. Push plug (201) into packing nut.

# Motor

**NOTE:** See Fig. 12 except where noted.

1. Try to stop pump with piston rod (222) in lowest position. To lower piston rod manually, remove shroud (32) and rotate motor fan blades. Use a screwdriver to push retaining spring (15) up and push out pin (14). See Fig. 10.
2.  Relieve pressure; page 3.
3. Remove motor shield (32).
4. Lift connecting rod. Remove screws (25, 26) and lower heat sink (22) and motor control board (22a). Disconnect motor wires and pressure transducer wire (A) from motor control board. Remove heat sink (22) and motor control board (22a), screws (23), and junction box (20). Refer to Fig. 12 and 4.
5. Remove drive housing cover (11).
6. Turn displacement pump rod (222) so pin hole aligns with bottom drive housing screw (16). See Fig. 11. Remove three drive housing screws and lockwashers (16, 4). See Fig. 11 and 12.
7. Remove two motor screws and lockwashers (3, 4).
8. Tap lower rear of drive housing (2) with a plastic mallet to loosen motor. Pull drive housing straight off motor while guiding pressure transducer wire (A) from motor. Do not allow gear (13) to fall. Read CAUTION on page 15.
9. Remove four screws (75) and lift motor off cart (70).

trolls  
t

10. Align new motor with cart and reinstall screws (75).
11. Assemble drive housing to motor. Follow steps 9 to 15 on page 15. Install junction box.
12. Connect wires to motor control board (22a). Refer to Fig. 4. Install motor control board.
13. Connect piston rod (222) to drive housing; see page 11, **Installing Pump**, Step 2 and WARNING following it.
14. Install shroud (32) and drive housing cover (11).

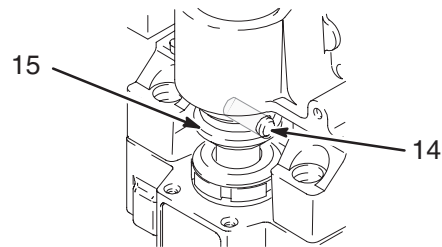

**Fig. 10** 7840A

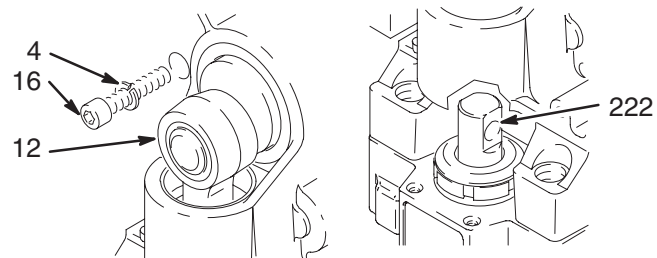

**Fig. 11** 7840A

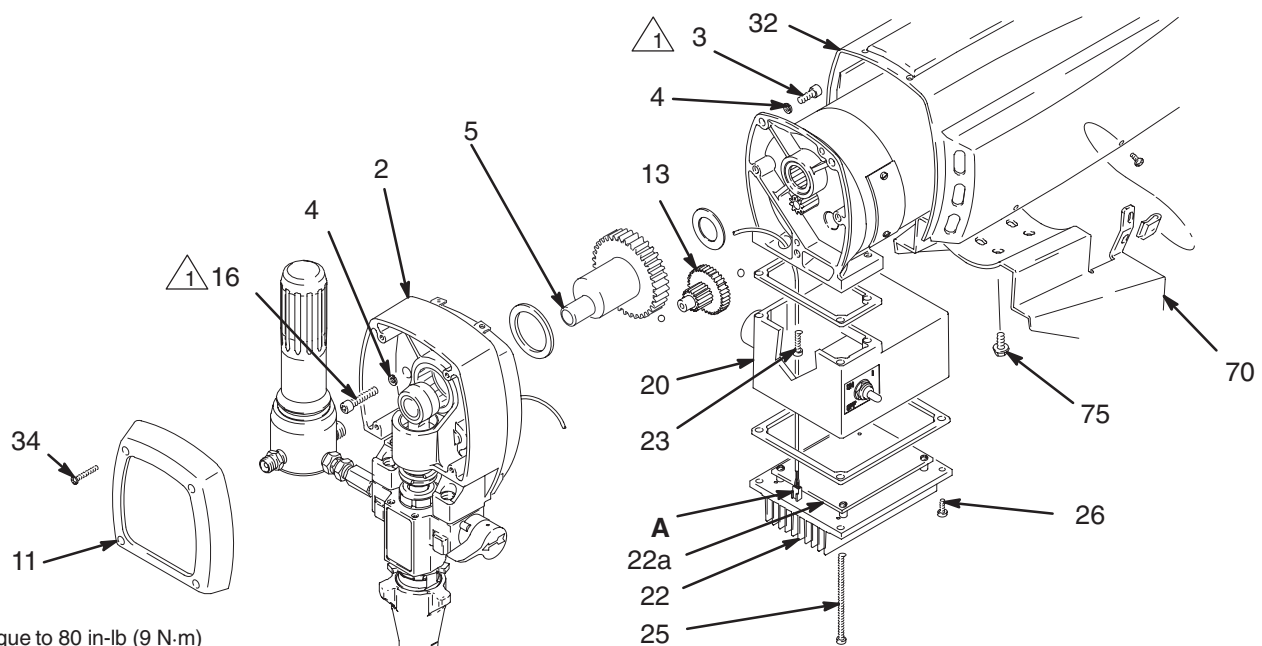

 Torque to 80 in-lb (9 N·m)

**Fig. 12**  
**12 309067**

9664A

# Pressure Control Repair

## Motor control board removal

1.  Relieve pressure; page 3.
2. Remove screws (25, 26) and lower heat sink (22) and motor control board (22a). See Fig. 12.
3. Disconnect wires (C), (D), (96), (E) and 108 from motor control board (22a). See Fig. 4.
4. Disconnect potentiometer (77) and transducer (67) from motor control board (22a).
5. Remove four screws and motor control board (22a).

6. Install new motor control board (22a) with four screws. Reconnect all wires and secure heat sink (22) to junction box (20).

### CAUTION

To reduce the risk of a malfunction:

- Be sure the flat blade of the insulated male connector is centered in the wrap-around blade of the female connector when the connections are made.
- Route all wires carefully to avoid interference with the motor control board or junction box.

## Motor control board diagnostics

1.  Relieve pressure; page 3.
2. Remove screws (25, 26) and lower heat sink (22) and motor control board (22a). See Fig. 12.
3. Turn ON/OFF switch ON.
4. Observe LED operation and reference following table:

LED BLINKS	SPRAYER OPERATION	INDICATES	WHAT TO DO
Once	Sprayer runs	Normal operation	Do nothing
Twice	Sprayer runs	Normal operation	Do nothing
Two times repeatedly	Sprayer shuts down and LED continues to blink two times repeatedly	Run away pressure. Pressure greater than 4500 psi.	Replace motor control board. See preceding Motor control board removal procedure.
Three times repeatedly	Sprayer shuts down and LED continues to blink three times repeatedly	Pressure transducer is faulty or missing	Replace pressure transducer
Four times repeatedly	Sprayer shuts down and LED continues to blink four times repeatedly	Line voltage is too high	Lower line voltage to 230 VAC for 232918, 232915, 232914; to 120 VAC for 232910 – 232913, 232919; and to 100 VAC for 232916, 232917
Five times repeatedly	Sprayer shuts down and LED continues to blink five times repeatedly	Locked rotor. Motor can not turn because of some mechanical condition.	Clear obstruction and replace broken parts preventing motor from turning

# Power Cord

## 232916, 232917, 232910–232913

1.  Relieve pressure; page 3.
2. Remove screws (25, 26) and lower heat sink (22). See Fig. 12.
3. Disconnect power cord leads (30), including green wire to grounding screw (78). See Fig. 4.
4. Loosen strain relief bushing (29). Remove power cord (30).
5. Install new cord (30) in reverse order of disassembly.

6. Install heat sink (22). Be sure no leads are pinched between heat sink and junction box (20).

## 232915, 232918, 232919 and 232914

1.  Relieve pressure; page 3.
2. Loosen screw on power cord retainer (120) and remove power cord (30).
3. Install new power cord (30) and tighten screw on power cord retainer (120).

# On/Off Switch

1.  Relieve pressure; page 3.
2. Remove screws (25, 26) and lower heat sink (22). See Fig. 14.
3. Remove rubber boot (82). See page 20.
4. Disconnect black, white, brown and blue wires from ON/OFF switch (80) and remove switch. See Fig. 4.

5. Install switch so internal tab of anti-rotation ring (81) engages with vertical groove in threads of switch, and external tab engages with slot of junction box. See page 20.
6. Powder inside of rubber boot (82) with talcum, then shake excess out of boot. Install nut and rubber boot and tighten.
7. Reconnect black, white, brown and blue wires to ON/OFF switch (80).
8. Install heat sink (22) with screws (25, 26). See Fig. 14. Be sure no leads are pinched between motor control board or other components.

# Pressure Adjusting Potentiometer

1.  Relieve pressure; page 3.
2. Remove screws (25, 26) and lower heat sink (22). See Fig. 14.
3. Remove potentiometer knob (27).
4. Remove shaft sealing nut (76).

5. Disconnect and remove potentiometer (77).
6. Install and connect new potentiometer (77).
7. Install shaft sealing nut (76).
8. Install potentiometer knob (27).
9. Install heat sink (22) with screws (25, 26). See Fig. 14. Be sure no leads are pinched between motor control board or other components.

# Drive Housing, Connecting Rod, Crankshaft

**NOTE:** Inspect parts as they are removed. Replace parts that are worn or damaged.

1.  Relieve pressure; page 3.

2. Remove displacement pump. See page 11.
3. Remove shroud (32).
4. Lower heat sink (22) and remove pressure transducer (67). See page 16.

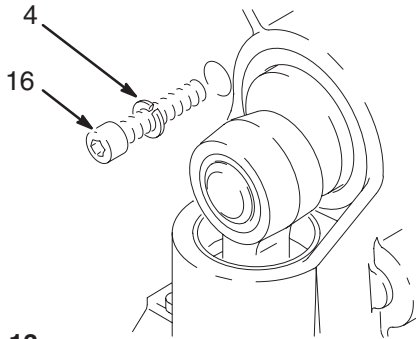

**Fig. 13** 7840A

5. Remove three drive housing screws (16) and lockwashers (4). Also see Fig. 14.
6. Remove two motor screws and lockwashers (3, 4). See Fig. 14.

## CAUTION

Do not allow gear (13) to fall; gear may stay attached to the drive housing or to the motor.

Do not lose the thrust balls (2a or 41) or let them fall between the gears, which will damage the drive housing if not removed. The balls, which are heavily covered with grease, usually stay in the gear recesses, but could be dislodged. If the balls are not in place, the bearings will wear prematurely.

**Note:** Filter & Displacement Pump not shown

 Torque to 80 in-lb (9 N·m)

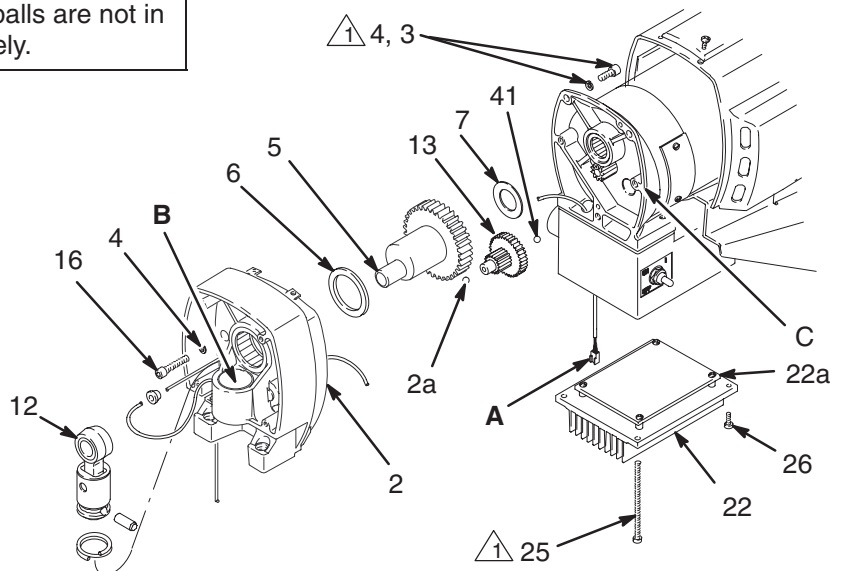

**Fig. 14**

7. Tap lower rear of drive housing (2) with a plastic mallet to loosen motor. Pull drive housing straight off motor.
8. Remove and inspect crankshaft (5) and connecting rod (12). Replace all damaged or worn parts.
9. Install connecting rod.
10. Lubricate inside of connecting rod bearing with SAE non-detergent oil. Pack roller bearing and gears with grease supplied.

**NOTE:** The gears and bearings between the drive housing (2) and motor front end bell (C) should contain a total of 3 fl oz (89 cc) of grease.

11. Place large washer (6) and then small washer (7) on crankshaft (5).
12. Rotate crank to top of stroke and insert crankshaft (5). Align gears and push drive housing (2) straight onto motor and locating pins. Install screws (16, 3) and their lockwashers (4). Torque to 80 in-lb (9 N·m).
13. Plug in pressure transducer. See page 16.
14. Install displacement pump. See page 11.
15. Install front cover (11).
16. Replace shroud (32).
17. Replace heat sink (22).

# Pressure Transducer

**NOTE:** See Fig. 14 and 15 for this procedure.

**NOTE:** The pressure transducer (67) cannot be repaired or adjusted. If it malfunctions, replace it.

## Removal

1.  Relieve pressure; page 3.
2. Remove displacement pump (18). See page 11.
3. Remove front cover (11). Remove screws (25, 26). Lower heat sink (22).
4. Disconnect harness connector from motor control board (22a). Remove grommet (65).
5. Remove retaining ring (66). Pull pressure transducer down and out past drive housing (2).
6. Guide harness (A) through motor and drive housing and remove pressure transducer.
7. Inspect spacer (68) and seal (69) for damage. Replace seal (69) only if it is cut, nicked, or if leakage occurred. See page 16.

## Installation

1. Using a small piece of solid copper or mild steel wire (approximately 12 in.), form a small hook and place it in the passage of bottom of the motor. Guide it up and out the hole in the drive housing.
2. Pass a spacer (68) over harness connector (A) and down into position at bottom of transducer (67).

3. Guide harness up through leg and notch of drive housing (2). Secure guide wire over connector.
4. While pulling guide wire out through bottom of motor, guide harness through drive housing and motor castings.
5. Place grommet (65) over harness and push into position in drive housing hole.
6. Feed excess harness cable through grommet and fully seat transducer body into hole in drive housing leg. Secure it with retaining ring (66).
7. Attach connector to motor control board (22a). Replace cover (11) and heat sink (22). Ensure no wires are pinched between components.

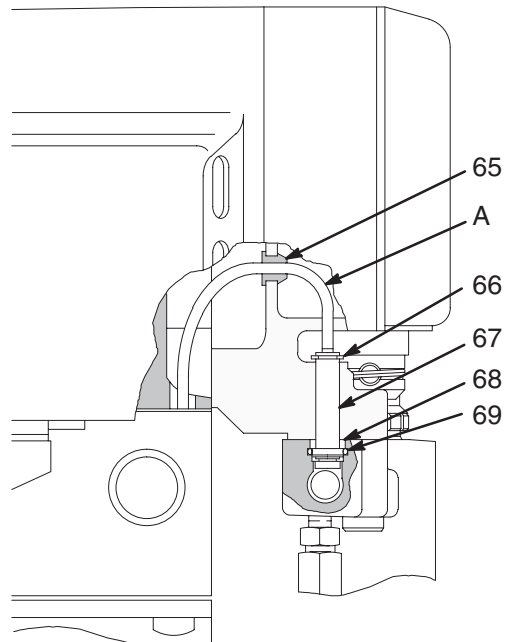

Fig. 15

02996A

# Pressure Transducer Seal

**NOTE:** PTFE seal is unaffected by most solvents and materials. Replace seal only when leakage occurs.

## Removal

1.  Relieve pressure; page 3.

2. Remove displacement pump (18). See page 11.
3. Remove seal (69) from recess in manifold (229).
4. Clean manifold recess with solvent and cloth or cotton swabs. Inspect for nicks or scratches.



# Pressure Transducer Seal

## Installation

1. Lightly coat cleaned packing recess in manifold with a light grease or oil.
2. Heat seal (69) in hot water for several minutes.

### CAUTION

Excess pressure from the probes or fingernails will damage the packing and cause subsequent leakage.

3. Use a blunt wooden or plastic probe and install seal (69) into recess in manifold (229). Be careful not to cause kinks or bends in packing during installation.

4. Lightly grease or oil transducer (67) and install pump (18). See page 11.

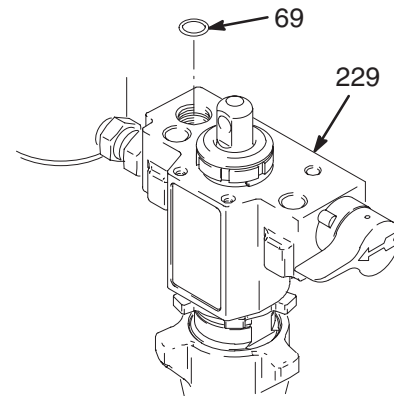

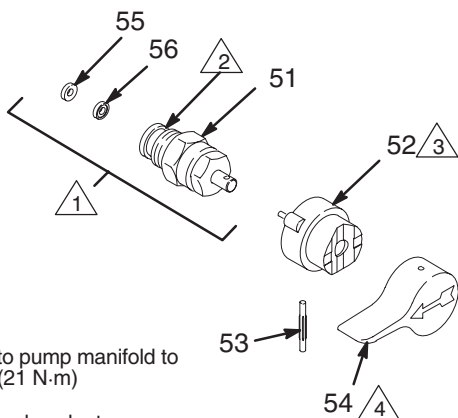

Fig. 16

9666A

# Drain Valve

1.  Relieve pressure; page 3.
2. Turn handle (54) to closed position. Drive out pin (53). Remove handle.
3. Remove base (52).
4. Unscrew drain valve assembly (51). gasket (55) and seat (56) will stay in valve.



- 1 Torque into pump manifold to 185 in-lb (21 N·m)
- 2 Apply thread sealant
- 3 Apply grease to face of base
- 4 Handle shown in closed position

Fig. 17

7839A

## Repair

1. Unscrew spring retainer from valve body. Remove spring, washers and stem/ball. Clean any debris from ball or seat area.
2. If replacing gasket (55) or seat (56), pry out gasket.

**NOTE:** Whenever gasket (55) is removed, replace it with a new one.

3. Place seat (56) in drain valve assembly (51) so lapped side is toward ball. Apply a small amount of grease to new gasket (55) and install it in drain valve assembly.

**NOTE:** The gasket will protrude from the end of the valve until the valve is tightened into pump, which correctly seats the gasket.

## Replacement

1. Apply a small amount of thread sealant (110110) onto drain valve assembly (51) threads. Tighten the valve into the pump manifold (229) to 185 in-lb (21 N·m).
2. Lightly grease face of base (52) and install base. Turn stem so pin hole is vertical.
3. Securely install handle (54) and drive pin (53).

# Technical Data

Power Requirements	
232914, 232915	240 VAC, 50 Hz, 1 phase, 10A minimum
232918	230 VAC, 50 Hz, 1 phase, 10A minimum
232919	120 VAC, 50/60 Hz, 1 phase, 15A minimum
232910 – 232913	120 VAC, 60 Hz, 1 phase, 15A minimum
232916, 232917	100 VAC, 50 Hz, 1 phase, 15A minimum
Generator	3000W minimum
Working Pressure Range	0–3000 psi (0–210 bar, 21 MPa)
Motor	0.9 HP <i>with latex at 2000 psi (138 bar, 13.8 MPa)</i>
Cycles/Gallon (liter)	566 (150)
Maximum Delivery Rating	0.6 gpm (2.3 lpm)
Tip Size	one gun to 0.026 new tip <i>with latex at 2000 psi (138 bar, 13.8 MPa)</i>
Power Cord	14 AWG, 3 wire, 15 ft (4.5 m)

Inlet Paint Strainer	16 mesh (975 micron) Stainless Steel Screen, reusable
Outlet Filter	60 mesh (238 micron)
Pump Inlet Size	3/4 npt(f)
Fluid Outlet Size	1/4 npsm
Sound Data:	
Sound Pressure Level	82dB(A)*
Sound Power Level	91dB(A)*
	*Measured while spraying with a .017 tip per ISO–3744
Wetted Parts:	Zinc-plated carbon steel, Aluminum, Stainless steel, Polyethylene, Delrin®, Leather Tungsten carbide, Chrome plating, Polyurethane
<b>NOTE:</b>	PTFE® and Delrin® are trademarks of the DuPont Company.

## Dimensions

### 232912, 232913, 232915, 232917

Weight (dry w/o packaging)	69 lb (31 kg)
Length (handle collapsed)	27 in. (686 mm)
Width	19.5 in. (495 mm)
Height (handle collapsed)	22 in. (559 mm)

### 232910, 232911, 232914, 232916, 232918, 232919

Weight (dry w/o packaging)	73 lb (33.1 kg)
Length	21 in. (533 mm)
Width	20.5 in. (521 mm)
Height (Handle Down)	28.5 in. (711 mm)

## Accessories

### DANGER LABELS

An English language DANGER label is on your sprayer. If you have painters who do not read English, order one of the following labels to apply to your sprayer. The drawing below shows the best placement of these labels for good visibility.

Order the labels directly from Graco, free of charge:  
1–800–328–0211

<b>French</b>	<b>187784</b>
<b>Spanish</b>	<b>185956</b>
<b>German</b>	<b>185961</b>
<b>Greek</b>	<b>186041</b>
<b>Korean</b>	<b>186045</b>
<b>English</b>	<b>187791</b>

Apply other language here

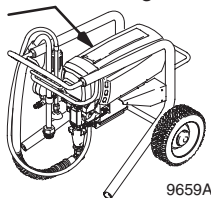

9659A

# Complete Sprayer Parts

232915, A  
232917, A

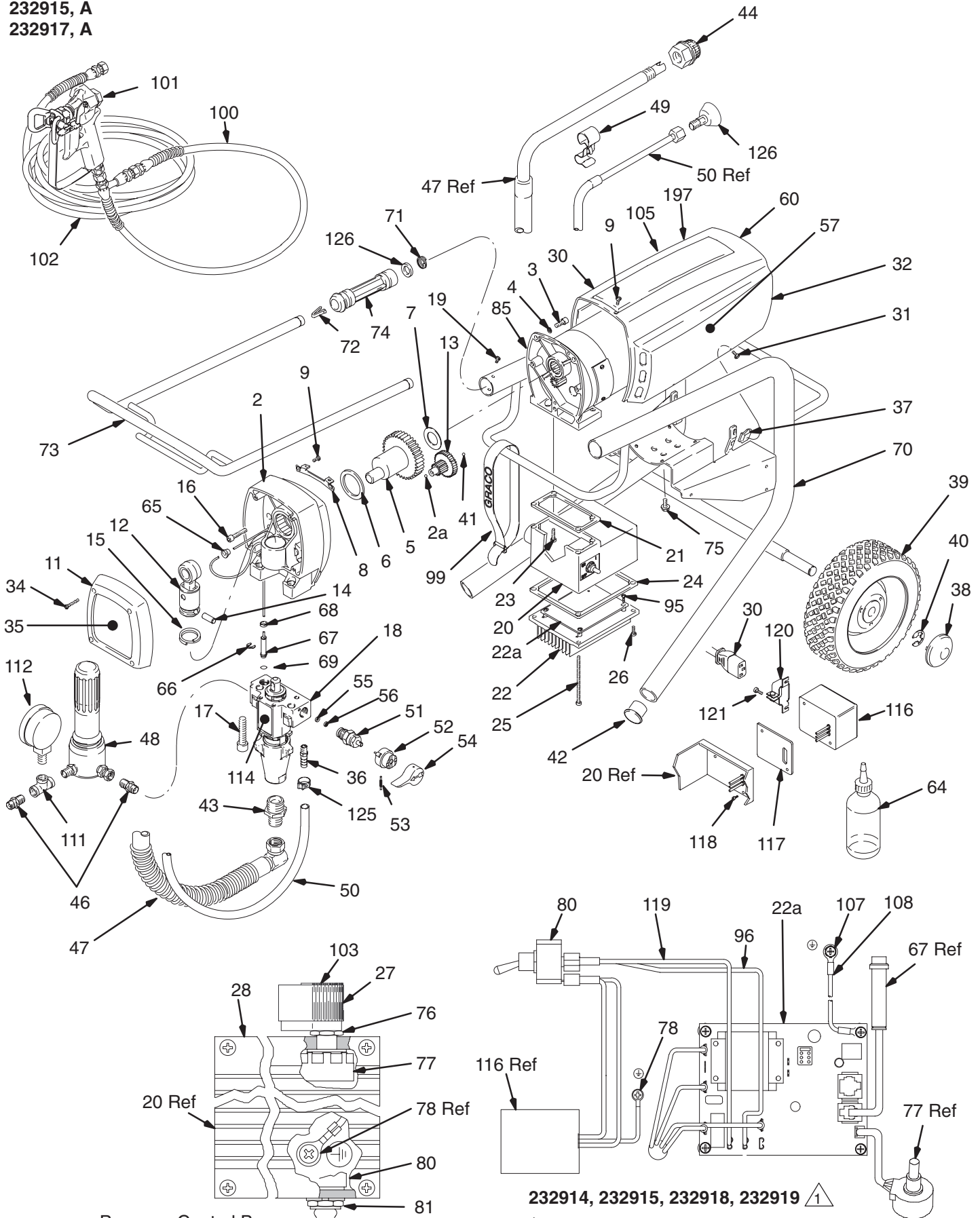

Pressure Control Box  
(Bottom View)

232914, 232915, 232918, 232919 1

1 232917; page 22

9668A

# Complete Sprayer Parts

232915, A; 232917, A

Ref. No.	Part No.	Description	Qty.	Ref. No.	Part No.	Description	Qty.
2	240057	KIT, housing, drive, U-695	1	54	187625	HANDLE, drain valve	1
2a	100069	BALL, thrust	1	55	111699	GASKET, seat valve	1
3	101682	SCREW, sch, 1/4-20 x .625	2	56	187615	SEAT, valve, lapped	1
4	105510	LOCKWASHER, 1/4 hi-collar	2	57▲		LABEL, DANGER, English	2
5	239979	CRANKSHAFT, U-695;	1		187791	232915	2
		232917	1		189702	232917	2
	218242	CRANKSHAFT, U-600; 232915	1	60▲		LABEL, WARNING, elec shock	1
6	180131	BEARING, thrust, front	1		187975	232918	1
7	107434	BEARING, thrust, rear	1		193520	232916	1
8	189270	BRACKET, shield	1	64	206994	LIQUID, throat seal	1
9	108865	SCREW, panh	4	65	114296	GROMMET, cable	1
11	236366	KIT, cover, front, U-695	1	66	112396	RING, external retaining	1
12		CONNECTING, rod assy	1	67	240514	TRANSDUCER, pressure control	1
	218359	232915	1	68	189269	SPACER, transducer	1
	240519	232917	1	69	104319	PACKING, o-ring, PTFE	1
13	218364	GEAR, assy, 2nd stage	1	70	243193	FRAME, cart, U-695	1
14	176818	PIN, straight	1	71	103117	RING, retaining	2
15	176817	SPRING, retaining	1	72	178565	BUTTON, spring	1
16	114811	SCREW, sch, 1/4-20 x 1.12	3	73	243205	HANDLE, cart	1
17	111706	SCREW, mach, sch, 7/16 x 1.75	2	74	195501	SLEEVE, cart	2
18	243189	KIT, pump, displacement	1	75	110997	SCREWS, 1/4-20 x .625	4
		Manual 308815		76	112382	NUT, shaft sealing	1
19	109032	SCREW, 10-32 x 0.25	4	77	236352	POTENTIOMETER, pressure adj	1
20		HOUSING, junction box		78	110037	SCREW, sldt hex hd, 10-24 x .375	1
	194435	232915	1	79	195673	WASHER	2
	189105	232917	1	80		SWITCH, toggle	1
21	112158	GASKET, motor	1		111826	232915	1
22	192844	HEAT SINK, does not include 22a	1		111930	232917	1
22a		KIT, board, control, motor		81	105658	RING, locking	1
		see manual 308816		82	105659	BOOT, toggle	1
	240561	232915	1	85		KIT, motor, electric, DC	
	240168	232917	1		243267	232915	1
23	112379	SCREW, filh, 10-24 x 0.75	2		240035	232917	1
24	112159	GASKET, heatsink	1	95	114420	SCREW	4
25	112381	SCREW, panh, 10-24 x 3.5	2	96		WIRE, electrical, 5", (F), 18 AWG	1
26	114417	SCREW, panh, 8-32 x 0.5	2		241546	232915	1
27	114273	KNOB, potentiometer	1		240495	232917	1
28	193056	LABEL, pressure adjust	1	97	192838	LABEL, warning	2
29†	114284	CLAMP, power cord	1	99	114271	STRAP, hose	1
30		CORD, power set	1	100†	238358	HOSE, whip, 3/16" x 3'	1
	241731	232915	1	101†	220955	SPRAY GUN, contractor	1
	240721	232917	1			manual 307614	
31	114053	SCREW, trusshead, 8-32	2	102†	220794	HOSE, 1/4" x 50'	1
32	240318	KIT, shield, motor, U-695	1	103▲	193072	LABEL, pressure	1
		includes 9, 31, & 37; 33 & 57		105▲	192838	LABEL, WARNING, French	1
33▲†	187784	LABEL, DANGER, French	2	107	114422	SCREW, pnhd	1
34	114406	SCREW, filh, 8-32 x 1.0	4	108	240498	WIRE, ground	1
35	192617	LABEL, cover, front	1	109‡	193521	LABEL, caution (not shown)	1
36	115787	ADAPTER, tube	1	110		LABEL, caution (not shown)	1
37	114052	NUT, self-retaining	2		192839	232915	1
38	104811	CAP, hub	2		189699	232917	1
39	195766	WHEEL, semi-pneumatic	2	111†	104984	TEE	1
40	101242	RING, retaining	2	112†	102814	GAUGE	1
41	100069	BALL, thrust	1	114	192849	LABEL, WARNING	1
42	112759	PLUG, tube	2	116†	241337	FILTER, power inlet	1
43	157191	FITTING, adapter	1	117†	187962	GASKET	1
44	235004	STRAINER, 1/2 npsm	1	118†	111839	SCREW	2
46	193718	NIPPLE, 1/4 npt x 1/4 npsm	1	119†	241545	WIRE, electrical	1
47	241937	HOSE, suction, swivel	1	120†	115098	RETAINER, cord	1
48	240711	FILTER, fluid; manual 308249	1	121†	111840	SCREW	2
49	195186	CLIP, spring	1	125	114974	CLAMP, outlet	1
50	241936	HOSE, drain assy	1	126	241920	DEFLECTOR	1
51	235014	ASSEMBLY, drain valve	1			▲ Extra Warning Labels available free	
		includes 55 and 56				† 232915 only	
52	224807	VALVE, base	1			‡ 232917	
53	111600	PIN, grooved	1				

# Complete Sprayer Parts

232914, A  
 232916, A  
 232918, A  
 232919, A

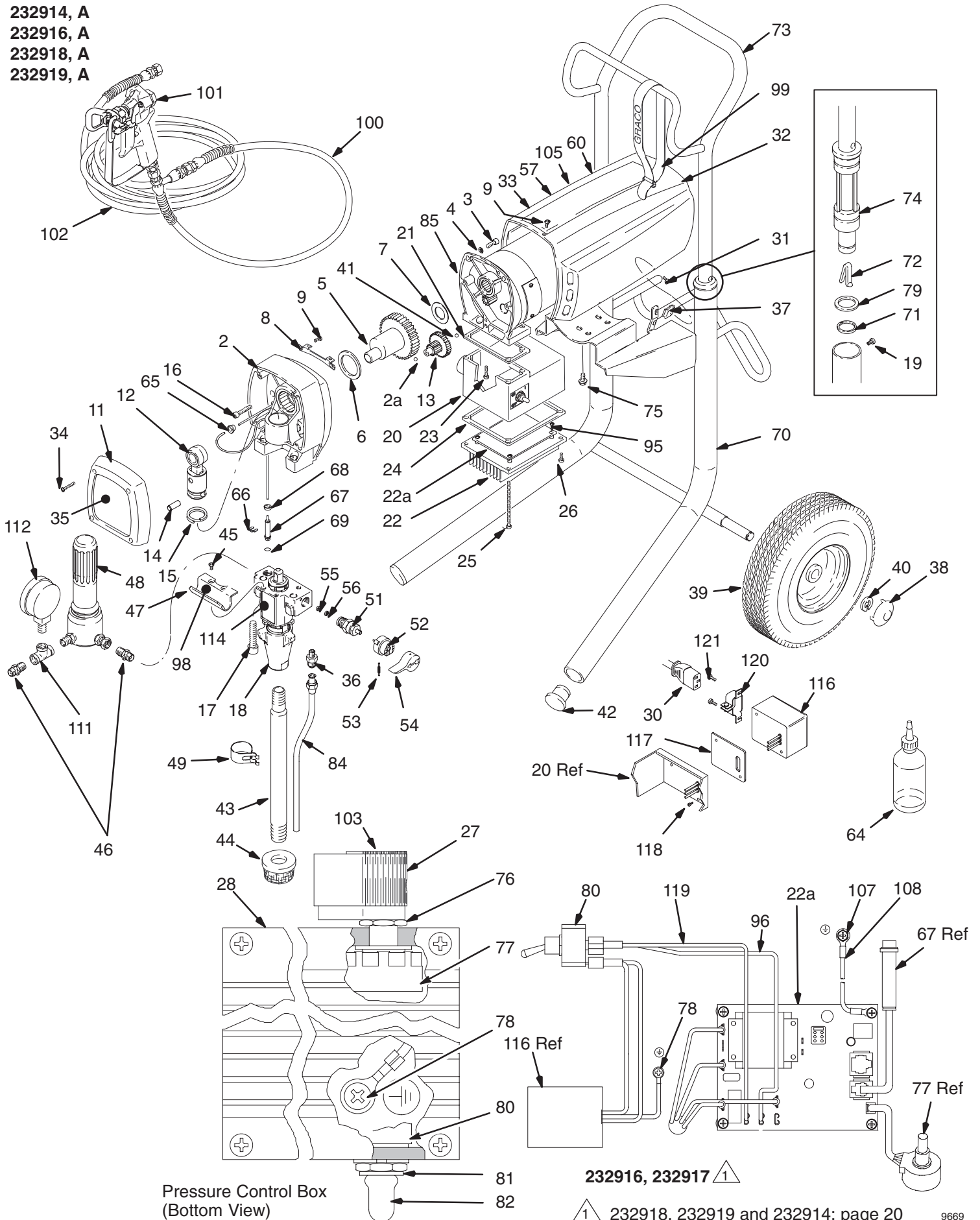

Pressure Control Box  
 (Bottom View)

232916, 232917

232918, 232919 and 232914; page 20

# Complete Sprayer Parts

232918, A; 232916, A; 232919, A; 232914, A

Ref. No.	Part No.	Description	Qty.	Ref. No.	Part No.	Description	Qty.
2	240057	<b>KIT, housing, drive, U-695</b>	1	54	187625	HANDLE, drain valve	1
2a	100069	BALL, thrust	1	55	111699	GASKET, seat valve	1
3	101682	SCREW, sch, 1/4-20 x .625	2	56	187615	SEAT, valve, lapped	1
4	105510	LOCKWASHER, 1/4 hi-collar	2	57▲		LABEL, DANGER, English	
5	239979	<b>CRANKSHAFT, U-695;</b>	1		187791	232918, 232919 and 232914	2
		<b>232916, 232918 and 232919</b>	1		189702	232916	2
	218242	<b>CRANKSHAFT, U-600; 232914</b>	1	60▲		LABEL, WARNING, elec shock	1
6	180131	BEARING, thrust, front	1		187975	232918, 232919 and 232914	1
7	107434	BEARING, thrust, rear	1		193520	232916	1
8	189270	BRACKET, shield	1	64	206994	LIQUID, throat seal	1
9	108865	SCREW, panh	5	65	114296	GROMMET, cable	1
11	236366	KIT, cover, front, U-695	1	66	112396	RING, external retaining	1
12		<b>CONNECTING, rod assy</b>		67	240514	TRANSDUCER, pressure control	1
	240519	<b>232916, 232918 and 232919</b>	1	68	189269	SPACER, transducer	1
	218359	<b>232914</b>	1	69	104319	PACKING, o-ring,PTFE	1
13	218364	GEAR, assy, 2nd stage	1	70	240007	FRAME, cart, U-695	1
14	176818	PIN, straight	1	71	110243	RING, retaining, handle	2
15	176817	SPRING, retaining	1	72	111590	BUTTON, spring	2
16	114811	SCREW, sch, 1/4-20 x 1.12	3	73	239998	HANDLE, cart	1
17	111706	SCREW, mach, sch, 7/16 x 1.75	2	74	192027	SLEEVE, cart	2
18	243189	<b>KIT, pump, displacement;</b>	1	75	110997	SCREWS, 1/4-20 x .625	4
		Manual 308815		76	112382	NUT, shaft sealing	1
19	109032	SCREW, 10-24 x 0.250	4	77	236352	<b>POTENTIOMETER, pressure adj</b>	1
20		HOUSING, junction box		78	110037	SCREW, sltd hex hd, 10-24 x .375	1
	194435	232918, 232919 and 232914	1	79	183350	WASHER, flat	2
	189105	232916	1	80		SWITCH, toggle	
21	112158	GASKET, motor	1		111826	232918, 232919 and 232914	1
22	192844	HEAT SINK, does not include 22a	1		111930	232916	1
22a		<b>KIT, board, control, motor</b>		81	105658	RING, locking	1
		Manual 308816		82	105659	BOOT, toggle	1
	240561	232918 and 232914	1	84	240017	TUBE, drain	1
	240168	232916 and 232919	1	85		<b>KIT, motor, electric, DC</b>	
23	112379	SCREW, filh, 10-24 x 0.75	2		243267	232914	1
24	112159	GASKET, heatsink	1		240511	232918	1
25	112381	SCREW, panh, 10-24 x 3.5	2		240035	232916 and 232919	1
26	114417	SCREW, panh, 8-32 x 0.5	2	95	114420	SCREW	4
27	114273	KNOB, potentiometer	1	96		WIRE, electrical, 5", (F), 18 AWG	
28	193056	LABEL, pressure adjust	1		241546	232918, 232919 and 232914	1
29†	114284	CLAMP, power cord	1		240495	232916	1
30		CORD, power set	1	98▲	192840	LABEL, WARNING, finger pinch	1
	241731	232914	1	99	114271	STRAP, hose	1
	241547	232918	1	100†	238358	HOSE, whip, 3/16" x 3'	1
	240721	232916	1	101†	220955	<b>SPRAY GUN, contractor</b>	1
	238964	232919	1			<b>Manual 307614</b>	
31	114053	SCREW, trusshead, 8-32	2	102†	240794	HOSE, 1/4" x 50'	1
32	240318	<b>KIT, shield, motor, U-695</b>	1	103▲	193072	LABEL, pressure	1
		includes 9, 31, & 37; 33 & 57		105▲	192838	LABEL, WARNING, French	1
33▲	187784	LABEL, DANGER, French	2	107	114422	SCREW, pnhd	1
34	114406	SCREW, filh, 8-32 x 1.0	4	108	240498	WIRE, ground	1
35	192617	LABEL, cover, front	1	109‡	193521	LABEL, caution (not shown)	1
36	111612	ADAPTER, tube	1	110		LABEL, caution (not shown)	
37	114052	NUT, self-retaining	2		192839	232918, 232919 and 232914	1
38	104811	CAP, hub	2		189699	232916	1
39	106062	WHEEL, semi-pneumatic	2	111†	104984	TEE	1
40	101242	RING, retaining, wheel	2	112†	102814	GAUGE	1
41	100069	BALL, thrust	1	114	192849	LABEL, WARNING	1
42	108691	PLUG, tube	2	116†	241337	FILTER, power inlet	1
43	192809	TUBE, suction	1	117†	187962	GASKET	1
44	187190	STRAINER	1	118†	111839	SCREW	2
45	112777	SCREW, 8-32 x 3/8	2	119†	241545	WIRE, electrical, 5 in., 14 AWG	1
46	193718	NIPPLE, 1/4 npt x 1/4 npsm	2	120		RETAINER, cord	1
47	190321	HANGER, pail	1		115098	232918 and 232914	1
48	240711	<b>FILTER, fluid;</b> Manual 308249			115526	232919	1
49	192648	CLIP, spring	1	121†	111840	SCREW	2
51	235014	<b>ASSY, drain valve;</b> includes 55 and 56	1				
52	224807	VALVE, base	1				
53	111600	PIN, grooved	1				

▲Extra Warning Labels available free

† 232918, 232919 and 232914

‡ 232916

# Complete Sprayer Parts

Model 232912 and 232913, Series A

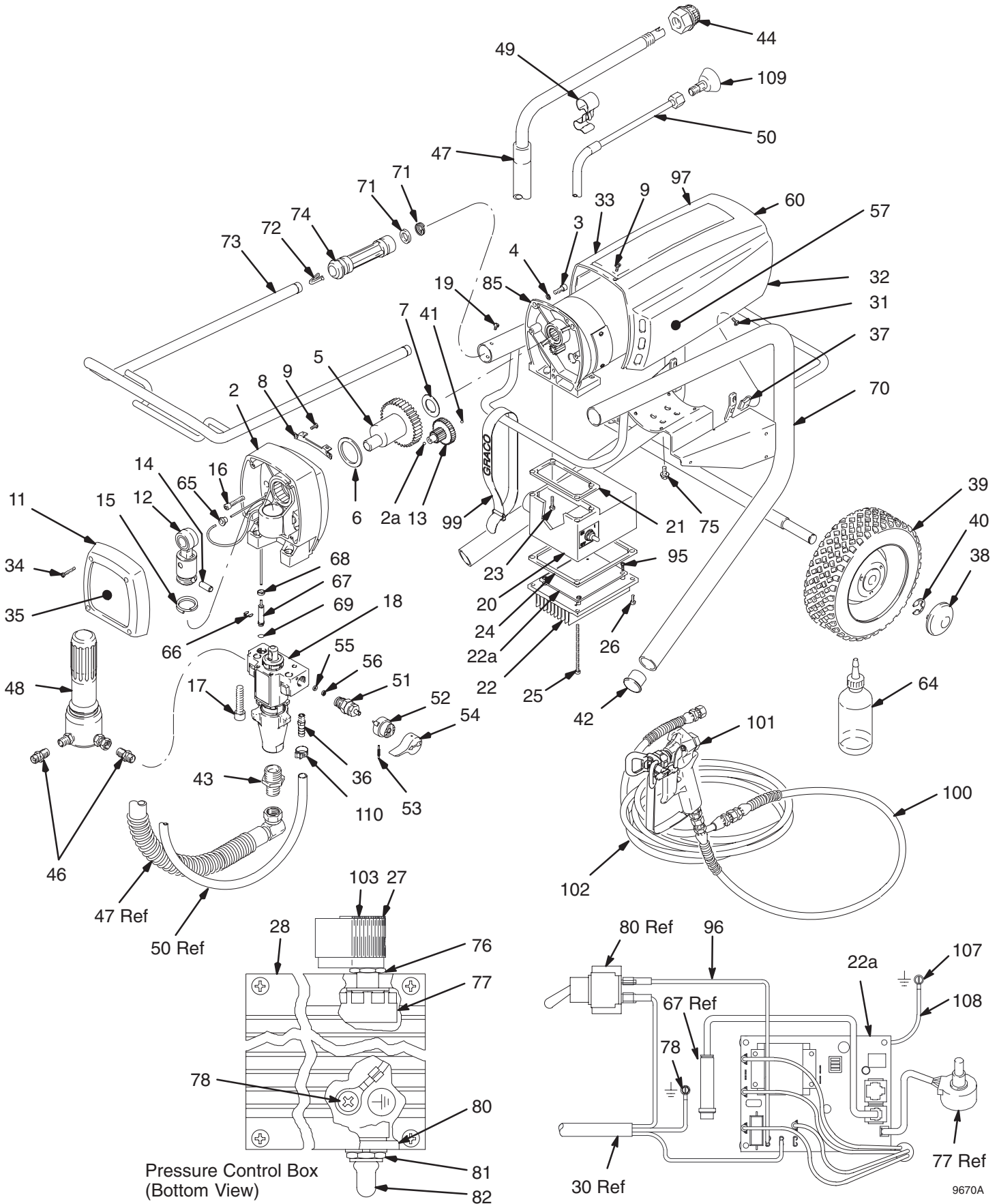

9670A



# Complete Sprayer Parts

Model 232912 and 232913, Series A

Ref. No.	Part No.	Description	Qty.	Ref. No.	Part No.	Description	Qty.
2	240057	<b>KIT, housing, drive, U-695</b>	1	49	195186	CLIP, spring	1
2a	100069	BALL, thrust	1	50	241936	HOSE, drain assy	1
3	101682	SCREW, sch, 1/4-20 x .625	2	51■	<b>235014</b>	<b>ASSEMBLY, drain valve includes 55 and 56</b>	1
4	105510	LOCKWASHER, 1/4 hi-collar	2	52	224807	VALVE, base	1
5	239979	CRANKSHAFT, U-695	1	53	111600	PIN, grooved	1
6	180131	BEARING, thrust, front	1	54	187625	HANDLE, drain valve	1
7	107434	BEARING, thrust, rear	1	55	111699	GASKET, seat valve	1
8	189270	BRACKET, shield	1	56	187615	SEAT, valve, lapped	1
9	108865	SCREW, panh	5	57▲	187791	LABEL, DANGER, English	2
11	236366	KIT, cover, front, U-695	1	60▲	187975	LABEL, WARNING, elec shock	1
12	<b>240519</b>	<b>CONNECTING, rod assy</b>	1	64	206994	LIQUID, throat seal	1
13	218364	GEAR, assy, 2nd stage	1	65	114296	GROMMET, cable	1
14	176818	PIN, straight	1	66	112396	RING, external retaining	1
15	176817	SPRING, retaining	1	67	240514	TRANSDUCER, pressure control	1
16	114811	SCREW, sch, 1/4-20 x 1.12	3	68	189269	SPACER, transducer	1
17	111706	SCREW, mach, sch, 7/16 x 1.75	2	69	104319	PACKING, o-ring, PTFE®	1
18	<b>243189</b>	<b>KIT, pump, displacement see manual 308815</b>	1	70	243193	FRAME, cart, U-695	1
19	109032	SCREW, 10-32 x 0.25	4	71	103117	RING, retaining	2
20	189105	HOUSING, junction box	1	72	178565	BUTTON, spring	1
21	112158	GASKET, motor	1	73	243205	HANDLE, cart	1
22	192844	HEAT SINK, does not include 22a	1	74	195501	SLEEVE, cart	2
22a	<b>240168</b>	<b>KIT, board, control, motor see manual 308816</b>	1	75	110997	SCREWS, 1/4-20 x .625	4
23	112379	SCREW, filh, 10-24 x 0.75	2	76	112382	NUT, shaft sealing	1
24	112159	GASKET, heatsink	1	77	236352	POTENTIOMETER, pressure adj	1
25	112381	SCREW, panh, 10-24 x 3.5	2	78	110037	SCREW, sltd hex hd, 10-24 x .375	1
26	114417	SCREW, panh, 8-32 x 0.5	2	79	195673	WASHER	2
27	114273	KNOB, potentiometer	1	80	111930	SWITCH, toggle	1
28	193056	LABEL, pressure adjust	1	81	105658	RING, locking	1
29	108295	BUSHING, strain relief	1	82	105659	BOOT, toggle	1
30	239995	CORD, power set	1	85	<b>240035</b>	<b>KIT, motor, electric, DC</b>	1
31	114053	SCREW, trusshead, 8-32	2	95	114420	SCREW	4
32	<b>240318</b>	<b>KIT, shield, motor, U-695 includes 9, 31, &amp; 37; 33 &amp; 57</b>	1	96	240495	WIRE, electrical, 5", (F), 18 AWG	1
33▲	187784	LABEL, DANGER, French	2	97	192838	LABEL, warning	2
34	114406	SCREW, filh, 8-32 x 1.0	4	99	114271	STRAP, hose	1
35	192617	LABEL, cover, front	1	100*	214701	HOSE, whip, 3/16" x 3'	1
36	115787	FITTING, outlet	1	101*	<b>220955</b>	<b>SPRAY GUN, contractor Manual 307614</b>	1
37	114052	NUT, self-retaining	2	102*	223541	HOSE, 1/4" x 50'	1
38	104811	CAP, hub	2	103▲	193072	LABEL, pressure	1
39	195766	WHEEL, semi-pneumatic	2	107	114422	SCREW, pnhd	1
40	101242	RING, retaining	2	108	240498	WIRE, ground	1
41	100069	BALL, thrust	1	109	241920	DEFLECTOR	1
42	107310	PLUG, tube	2	110	114974	CLAMP, outlet	1
43	157191	FITTING, adapter	1	<b>*Not supplied with sprayer Model 232912</b>			
44	235004	STRAINER, 1/2 npsm	1	<b>▲Extra Warning Labels available free</b>			
46	193718	NIPPLE, 1/4 npt x 1/4 npt	1	■ Replace o-ring 169110 in Ref. No. 51 assembly 235014 with 112319 if using severe solvents such as lacquer thinner and acetone.			
47	241937	HOSE, suction, swivel	1				
48	<b>240038</b>	<b>FILTER, fluid see manual 308249</b>	1				

# Complete Sprayer Parts

Model 232910 and 232911, Series A

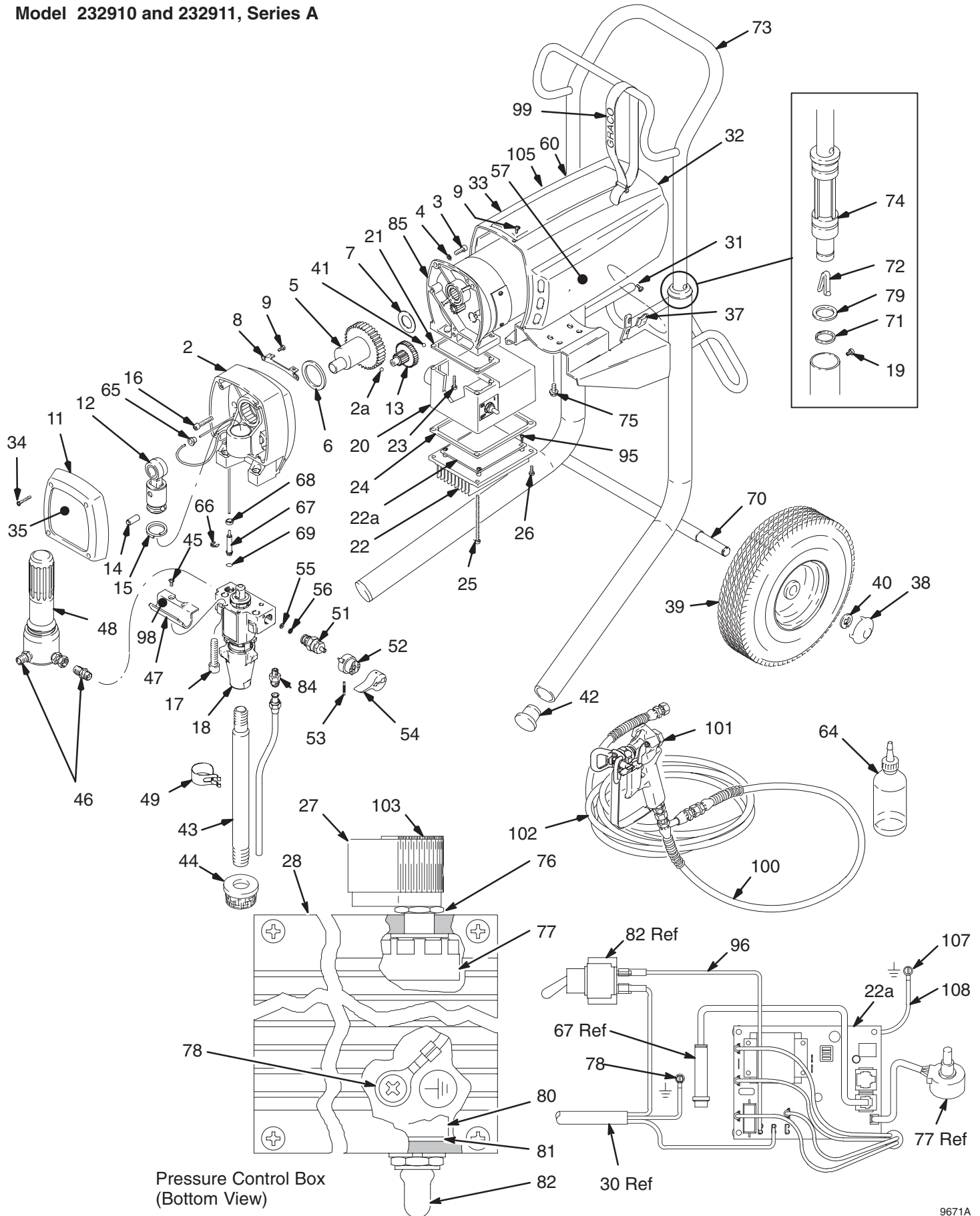

Pressure Control Box  
(Bottom View)

# Complete Sprayer Parts

Model 232910 and 232911, Series A

Ref. No.	Part No.	Description	Qty.	Ref. No.	Part No.	Description	Qty.
2	240057	<b>KIT, housing, drive, U-695</b>	1	49	192648	CLIP, spring	1
2a	100069	BALL, thrust	1	51■	235014	<b>ASSEMBLY, drain valve includes 55 and 56</b>	1
3	101682	SCREW, sch, 1/4-20 x .625	2	52	224807	VALVE, base	1
4	105510	LOCKWASHER, 1/4 hi-collor	2	53	111600	PIN, grooved	1
5	239979	<b>CRANKSHAFT, U-695</b>	1	54	187625	HANDLE, drain valve	1
6	180131	BEARING, thrust, front	1	55	111699	GASKET, seat valve	1
7	107434	BEARING, thrust, rear	1	56	187615	SEAT, valve, lapped	1
8	189270	BRACKET, shield	1	57▲	187791	LABEL, DANGER, English	2
9	108865	SCREW, panh	5	60▲	187975	LABEL, WARNING, elec shock	1
11	236366	KIT, cover, front, U-695	1	64	206994	LIQUID, throat seal	1
12	240519	<b>CONNECTING, rod assy</b>	1	65	114296	GROMMET, cable	1
13	218364	GEAR, assy, 2nd stage	1	66	112396	RING, external retaining	1
14	176818	PIN, straight	1	67	240514	TRANSDUCER, pressure control	1
15	176817	SPRING, retaining	1	68	189269	SPACER, transducer	1
16	114811	SCREW, sch, 1/4-20 x 1.12	3	69	104319	PACKING, o-ring, PTFE®	1
17	111706	SCREW, mach, sch, 7/16 x 1.75	2	70	240007	FRAME, cart, U-695	1
18	243189	<b>KIT, pump, displacement Manual 308815</b>	1	71	110243	RING, retaining, handle	2
19	109032	SCREW, 10-24 x 0.250	4	72	111590	BUTTON, spring	2
20	189105	HOUSING, junction box	1	73	239998	HANDLE, cart	1
21	112158	GASKET, motor	1	74	192027	SLEEVE, cart	2
22	192844	HEAT SINK, does not include 22a	1	75	110997	SCREWS, 1/4-20 x .625	4
22a	240168	<b>KIT, board, control, motor</b>	1	76	112382	NUT, shaft sealing	1
23	112379	SCREW, filh, 10-24 x 0.75	2	77	236352	<b>POTENTIOMETER, pressure adj</b>	1
24	112159	GASKET, heatsink	1	78	110037	SCREW, sltd hex hd, 10-24 x .375	1
25	112381	SCREW, panh, 10-24 x 3.5	2	79	183350	WASHER, flat	2
26	114417	SCREW, panh, 8-32 x 0.5	2	80	111930	SWITCH, toggle	1
27	114273	KNOB, potentiometer	1	81	105658	RING, locking	1
28	193056	LABEL, pressure adjust	1	82	105659	BOOT, toggle	1
29	108295	BUSHING, strain relief	1	84	240017	TUBE, drain	1
30	239995	CORD, power set	1	85	240035	<b>KIT, motor, electric, DC</b>	1
31	114053	SCREW, trusshead, 8-32	2	95	114420	SCREW	4
32	240318	<b>KIT, shield, motor, U-695 includes 9, 31, &amp; 37; 33 &amp; 57</b>	1	96	240495	WIRE, electrical, 5", (F), 18 AWG	1
33▲	187784	LABEL, DANGER, French	2	98▲	192840	LABEL, WARNING, finger pinch	1
34	114406	SCREW, filh, 8-32 x 1.0	4	99	114271	STRAP, hose	1
35	192617	LABEL, cover, front	1	100*	214701	HOSE, whip, 3/16" x 3'	1
37	114052	NUT, self-retaining	2	101*	220955	<b>SPRAY GUN, contractor Manual 307614</b>	1
38	104811	CAP, hub	2	102*	223541	HOSE, 1/4" x 50'	1
39	106062	WHEEL, semi-pneumatic	2	103▲	193072	LABEL, pressure	1
40	101242	RING, retaining, wheel	2	105▲	192838	LABEL, WARNING, French	1
41	100069	BALL, thrust	1	107	114422	SCREW, pnhd	1
42	108691	PLUG, tube	2	108	240498	WIRE, ground	1
43	192809	TUBE, suction	1				
44	187190	STRAINER, 1/2 npsm	1				
45	112777	SCREW, 8-32 x 38	2				
46	193718	NIPPLE, 1/4 npt x 1/4 npsm	2				
47	190321	HANGER, pail	1				
48	240038	<b>FILTER, fluid Manual 308249</b>	1				

\*Not supplied with sprayer Model 232910

▲Extra Warning Labels available free

■ Replace o-ring 168110 in Ref. No. 51 assembly 235014 with 112319 if using severe solvents such as lacquer thinner and acetone.

# Graco Standard Warranty

Graco warrants all equipment referenced in this document which is manufactured by Graco and bearing its name to be free from defects in material and workmanship on the date of sale by an authorized Graco distributor to the original purchaser for use. With the exception of any special, extended, or limited warranty published by Graco, Graco will, for a period of twelve months from the date of sale, repair or replace any part of the equipment determined by Graco to be defective. This warranty applies only when the equipment is installed, operated and maintained in accordance with Graco's written recommendations.

This warranty does not cover, and Graco shall not be liable for general wear and tear, or any malfunction, damage or wear caused by faulty installation, misapplication, abrasion, corrosion, inadequate or improper maintenance, negligence, accident, tampering, or substitution of non-Graco component parts. Nor shall Graco be liable for malfunction, damage or wear caused by the incompatibility of Graco equipment with structures, accessories, equipment or materials not supplied by Graco, or the improper design, manufacture, installation, operation or maintenance of structures, accessories, equipment or materials not supplied by Graco.

This warranty is conditioned upon the prepaid return of the equipment claimed to be defective to an authorized Graco distributor for verification of the claimed defect. If the claimed defect is verified, Graco will repair or replace free of charge any defective parts. The equipment will be returned to the original purchaser transportation prepaid. If inspection of the equipment does not disclose any defect in material or workmanship, repairs will be made at a reasonable charge, which charges may include the costs of parts, labor, and transportation.

**THIS WARRANTY IS EXCLUSIVE, AND IS IN LIEU OF ANY OTHER WARRANTIES, EXPRESS OR IMPLIED, INCLUDING BUT NOT LIMITED TO WARRANTY OF MERCHANTABILITY OR WARRANTY OF FITNESS FOR A PARTICULAR PURPOSE.**

Graco's sole obligation and buyer's sole remedy for any breach of warranty shall be as set forth above. The buyer agrees that no other remedy (including, but not limited to, incidental or consequential damages for lost profits, lost sales, injury to person or property, or any other incidental or consequential loss) shall be available. Any action for breach of warranty must be brought within two (2) years of the date of sale.

**GRACO MAKES NO WARRANTY, AND DISCLAIMS ALL IMPLIED WARRANTIES OF MERCHANTABILITY AND FITNESS FOR A PARTICULAR PURPOSE, IN CONNECTION WITH ACCESSORIES, EQUIPMENT, MATERIALS OR COMPONENTS SOLD BUT NOT MANUFACTURED BY GRACO.** These items sold, but not manufactured by Graco (such as electric motors, switches, hose, etc.), are subject to the warranty, if any, of their manufacturer. Graco will provide purchaser with reasonable assistance in making any claim for breach of these warranties.

In no event will Graco be liable for indirect, incidental, special or consequential damages resulting from Graco supplying equipment hereunder, or the furnishing, performance, or use of any products or other goods sold hereto, whether due to a breach of contract, breach of warranty, the negligence of Graco, or otherwise.

## **FOR GRACO CANADA CUSTOMERS**

The parties acknowledge that they have required that the present document, as well as all documents, notices and legal proceedings entered into, given or instituted pursuant hereto or relating directly or indirectly hereto, be drawn up in English. Les parties reconnaissent avoir convenu que la rédaction du présente document sera en Anglais, ainsi que tous documents, avis et procédures judiciaires exécutés, donnés ou intentés à la suite de ou en rapport, directement ou indirectement, avec les procédures concernées.

## **ADDITIONAL WARRANTY COVERAGE**

Graco does provide extended warranty and wear warranty for products described in the "Graco Contractor Equipment Warranty Program".

# Phone Number

**TO PLACE AN ORDER**, contact your Graco distributor, or call this number to identify the distributor closest to you:  
**1-800-690-2894 Toll Free**

*All written and visual data contained in this document reflects the latest product information available at the time of publication.  
Graco reserves the right to make changes at any time without notice.*

**Sales Offices:** Minneapolis, Detroit  
**Foreign Offices:** Belgium, Korea, Hong Kong, Japan

**GRACO INC. P.O. BOX 1441 MINNEAPOLIS, MN 55440-1441**

**<http://www.graco.com>**

PRINTED IN USA 309067 December 1999

## Free Manuals Download Website

<http://myh66.com>

<http://usermanuals.us>

<http://www.somanuals.com>

<http://www.4manuals.cc>

<http://www.manual-lib.com>

<http://www.404manual.com>

<http://www.luxmanual.com>

<http://aubethermostatmanual.com>

Golf course search by state

<http://golfingnear.com>

Email search by domain

<http://emailbydomain.com>

Auto manuals search

<http://auto.somanuals.com>

TV manuals search

<http://tv.somanuals.com>