

Oricom AM900

Amplified Digital Answering System



Keep this user guide for future reference

Always retain your proof of purchase in case of warranty service and register your product on line at:-
www.oricom.com.au



General Information	2
Location of Controls	4
Getting Started	6
Operation.....	8
Remote Access	13
Warranty.....	16

General Information



It is very important that you read the User Guide carefully as it contains detailed information on setup and operational issues which you will need to be aware of to ensure this product operates properly. Following is a list of **some** of the important issues and important warnings which you need to be aware of.

- The product is designed for indoor use only. Do not install in areas where there is the risk of an explosion, excessive exposure to smoke, dust, vibrations, chemicals, moisture and heat.
- Do not use this product during a thunderstorm as it is possible to get a shock. Refer to information contained in Telstra White pages directory.
- This product has been designed for individuals who are hard of hearing and has a normal playback volume which is louder than a standard product. Use of the boost button feature could cause hearing damage to individuals who are not experiencing hearing loss.
- Do not install in damp locations such as a bathroom or laundry, do not expose the unit to direct sunlight.
- Do not connect this product to an extension of a Digital Telephone system (PBX). Damage to this product or the phone system may occur.

Notes for operation in New Zealand

The grant of a Telepermit for any item of terminal equipment indicates only that Telecom has accepted that the item complies with minimum conditions for connection to its network. It indicates no endorsement of the product by Telecom, nor does it provide any sort of warranty. Above all, it provides no assurance that any item will work correctly in all respects with another item of Telepermitted equipment of a different make or model, nor does it imply that any product is compatible with all of Telecom's network services.

Telepermitted equipment only may be connected to the auxiliary telephone port. The auxiliary telephone port is not specifically designed for 3-wire-connected equipment, 3-wire-connected equipment might not respond to incoming ringing when attached to this port.

REN (RN for New Zealand)

The REN (Ringer Equivalence Number) or (RN) is of significance only if you wish to connect more than 1 telephone to your telephone line. A standard telephone line has a maximum REN capacity of 5 (RN of 5). It is possible to connect 5 devices with a REN of 1 (RN of 1) with no degradation to the product's performance. Exceeding this limit may cause the volume of the ringer in any phone to decrease or not ring at all.

Location of controls

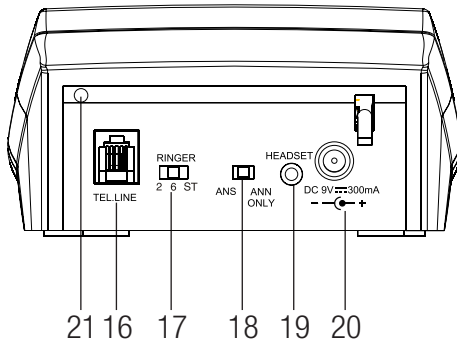
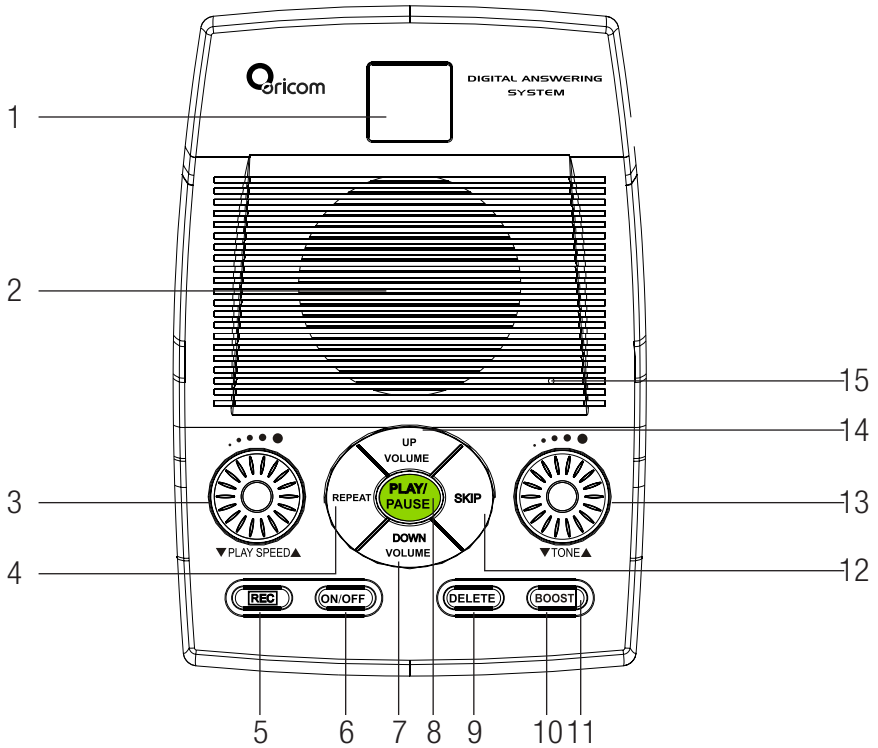

- | | |
|-----------------------|--|
| 1. Message LED | 12. SKIP button |
| 2. Microphone | 13. TONE switch |
| 3. PLAY SPEED Switch | 14. UP VOLUME button |
| 4. REPEAT button | 15. Speaker |
| 5. REC button | 16. Telephone Line Socket |
| 6. ON/OFF button | 17. Ringer 2/6/TS Switch |
| 7. DOWN VOLUME button | 18. ANS/ANS ONLY switch |
| 8. PLAY/PAUSE button | 19. Headset socket
(for headset not supplied) |
| 9. DELETE button | 20. Socket for AC Adaptor |
| 10. BOOST button | 21. Integrated Line cord |
| 11. BOOST Led | |

 **N13134** The A-Tick symbol indicates that this product complies with all current Australian ACMA standards.

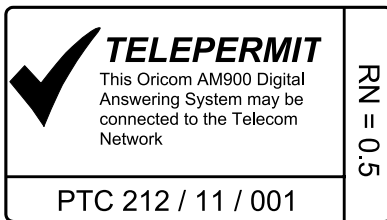

PACK CONTENTS

- 1 A900 Answering System
- 1 Energy efficient AC Adaptor
- 1 Australian Modular Adaptor Plug

Connecting your Oricom AM900

Example of Connecting the System

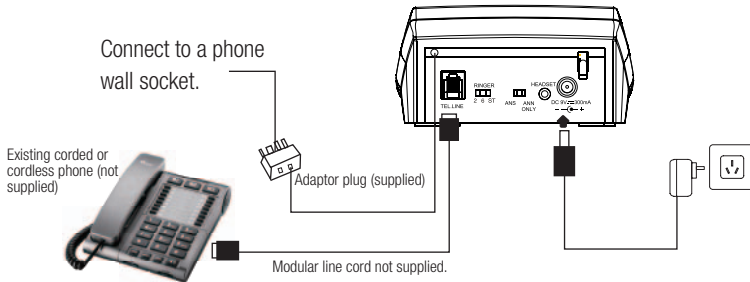

Depending on the type of phone and phone wall socket you have you may need to purchase a different type of telephone line adaptor plug. These are available from electronics stores.

Warning. Use only the AC adaptor supplied with this product. Incorrect adaptor polarity or voltage can seriously damage the AM900 and or be dangerous.

AC adaptor part number #: S005CS0900030, Input: 100-240V, 50/60 Hz, Output: DC9V 300mA

1. Plug the AC adaptor into a power point.
2. Plug the small plug on the AC adaptor into the socket on the rear of the answering system.
3. After initialisation, the display will show **00** on the message counter.

Setting the day, time and Language

The answering system always saves the day of the week and the time of day with each recorded message so that you always know when callers left their messages however the time and day must be set correctly.

If you want to enter the day, time and language for the first time or if you want to change a day and time that has already been set, please proceed as follows:

1. Press and hold the **SKIP** button for 2 seconds. You will hear the day of the week.
2. Press the **SKIP** button repeatedly until you hear the correct day of the week.

3. Press the **REPEAT** button. You will hear an announcement of the hour.
4. Press the **SKIP** button repeatedly until you hear the correct hour announced.
5. Press the **REPEAT** button. You will hear an announcement of the minutes currently set.
6. Press the **SKIP** button repeatedly until you hear the correct minutes announced.
7. Confirm with the **REPEAT** button and the day and time announcement will be repeated.

The day and time can be checked at any time. Simply press the **REPEAT** button and you will hear the day of the week and the current time of day.

NOTE:

If there is a pause of more than 20 seconds while entering the day, time, the programming will be interrupted.

Operation

Recording, changing or deleting the greeting message

For your outgoing greeting message (OGM), you can either use the pre-recorded greeting or you can record your own message. If you do not record a message, the standard greeting will be used automatically.

Before recording your greeting, you should write down the text that you want to record. The length of your own greeting must be at least 5 seconds and must not exceed 5 minutes. The longer your greeting lasts, the less recording time will be available for incoming messages. The maximum recording time is 50 minutes less the length of the Greeting Message.

Example of a greeting message: *“Hello this is Simon. I am sorry but we are not available to take your call at the moment. Please leave a message after the tone.”*

Recording your own greeting

Set the switch on the rear of the machine to ANS. Press and hold down the **REC** button.

start your greeting directly after you hear a tone. The display will show **A1** during the recording. While recording, keep 15 cm from the answering system so that you can speak into the microphone on the upper side.

Release the **REC** button after you have finish your greeting. The greeting will now be repeated. The playback volume can be adjusted by repeatedly pressing the **UP VOLUME** and **DOWN VOLUME** buttons. You can play back your greeting at any time by briefly pressing the **REC** button.

Using the Announcement Only Feature

Announce only feature lets you record an announcement for the caller, then, the system hangs up without letting the caller leave a message. This is ideal for business use where you need to make a service type announcement to callers but do not want to record incoming messages.

Set the switch on the rear of the machine to ANN ONLY.

Press and hold the **REC** button until you hear a tone.

Start recording your greeting (maximum length is 5 minutes) directly after the tone. The display will show **A2** during the recording.

Release the **REC** button after you have finished your recording.

NOTE:

When the system is set to ANN ONLY, you cannot set it to record calls using the remote commands. You can still use remote commands to perform all operations.

Deleting your own greeting and reverting to the pre-recorded greeting

If you have recorded your own greeting, you can delete this to revert back to the pre-recorded greeting.

Press and hold the **REC** button for 2 seconds until you hear a tone. Your own greeting will be deleted and you will hear the pre-recorded greeting in confirmation.

Setting up the answering system

On the rear of the answering system you will find a slide switch with which you can set to select how many times the phone rings before incoming calls are answered.

2 The call will be answered after 2 rings.

6 The call will be answered after 6 rings.

TS In Toll Saver mode incoming calls are answered after six rings until the first new message has been recorded. Once a message has been recorded the answering system will answer.

NOTE:

The Toll Saver function enables the user to check remotely for new messages without incurring a call charge.

General operation

The answering system can be switched off (standby) or on using the **ON/OFF** button. If the answering system is switched off, the display shows the message and no messages will be recorded.

The maximum length for incoming messages is 120 seconds. If the caller speaks for longer, a signal tone sounds and the call will be cut off. If there is a pause of more than 7 seconds during recording, the call is automatically terminated with a signal tone. No more calls will be answered if the memory capacity for new messages is exhausted and the message **FL** will appear in the display.

Listening to incoming messages

The integral speaker makes it possible to listen to incoming calls without speaking to the caller (sometimes called "Call Screening"). If you do not want to listen in to the incoming calls, set the volume right down by repeatedly pressing the ▼ arrow button.

Interrupting the answering system

You can personally intervene at any time while the caller is leaving their message. Simply lift the receiver of a parallel phone or press **ON/OFF** button on the answering machine. The answering system will stop recording and you can speak directly to the caller.

Listening to messages

The display shows the total number of messages recorded.

Listening to messages

Press the **PLAY/PAUSE** button once. Your system will play back the newly recorded messages first. If you have no new messages, all recorded messages will be played back. If no messages have been saved, you will hear several tones.

If you want to stop listening to messages, press the **PLAY/PAUSE** button. Pressing the **PLAY/PAUSE** button again within 7 seconds, will resume playback where you left off. Pressing the **ON/OFF** button will stop message playback. After the last message has been played, the unit responds with two tones. The speaker volume can be boosted up to +40dB max during message playback. Press the **BOOST** button, and the BOOST LED will light. You can then adjust the tone control by turning the tone control wheel. You can turn OFF the **BOOST** by pressing the **BOOST** button at anytime during message playback.

NOTE:

If you do not need this additional amplification you do not need to press the **BOOST** button.

Using the optional headset

You can use a headset with a 3.5mm plug (headset not supplied) to listen to the messages. simply plug in the headset to the socket in the rear of the Answering System.

Repeating previous message

Press and hold the **REPEAT** button until you hear a tone to repeat the previous message.

Repeating current message

Press the **REPEAT** button to repeat the message currently playing.

Skipping to next message

Press the **SKIP** button once to skip the message currently playing. The answering system now starts with the next message.

Fast forward

Press the **SKIP** button several times in succession. In this way, you can rapidly skip several messages.

Adjust the speed of message playback

You can adjust the speed of the message playback by turning the rotary PLAY SPEED wheel.

Deleting a single message

During message playback press and hold down the **DELETE** button until you hear a tone, the message is then deleted.

Save all messages

No input required.

Delete all messages

After the last message has been played, you will hear two tones. Now press the **DELETE** button until you hear a further tone.

Remote access

Remote access authorisation code

Your answering system has 3 digit personal access authorisation (Remote Code) so that only you can listen to incoming messages using the remote access facility. The authorisation code can be found on a label located on the underside of your unit.

Toll Saver

If you choose the Toll Saver option, and there are new messages, the system answers after two rings. Otherwise, the system answers after six rings. This lets you avoid unnecessary charges when calling to check your messages. If you hear more than two rings, you can hang up as the system has no new messages.

Set the slide control to the "TS" position. If you now call your system when you are away, the answering system answers as follows:

- A. If your call is answered after 2 rings, there are new messages on your answering system and you can continue as described under **Remote access facilities**
- B. If no new messages have been recorded, your call will not be answered after 2 rings. Hang up after the third ring. In this way, you can save the call charge.

Remote access facilities

Call your own telephone number and allow the greeting message to play through to the end. Wait until your answering system is ready to record a message. After the tone, enter your personal authorisation code by pressing the appropriate numbers on the phone.

Two tones confirm that the right code has been entered. Now select one of the functions listed below by pressing the appropriate combination of keys. The pause between entering the individual functions must not exceed 20 seconds as, otherwise, the connection will be cut off automatically.

Remote Access

Replay all recorded messages Press 2 and #

Replay newly recorded messages Press 2 and 5

Room monitoring Press 0 and #

While playing back, you have the following options:

Skip next message Press 7 and #

Repeat current message Press 8 and #

Repeat previous message Press 6 and #

Delete current message Press 3 and #

Stop current message Press # and #

After the last message, the system answers with several tones. Now, within the next 20 seconds, you have various possibilities. If you do not make any input within 20 seconds, the connection will be cut off automatically and all messages will remain saved.

Record memo Press 8 and #

Repeat all messages Press 2 and #

Delete all messages Press 3 and #

Switch off answering system Press 9 and #

After this input, the answering system is no longer ready for operation.

Save all messages no input required

Re-record greeting using remote access

1. Call your own telephone number and allow the greeting message to play through to the end. Wait until your answering system is ready to record a message.
2. After the tone, enter your personal authorization code by pressing the appropriate numbers on the telephone. Two tones confirm that the right code has been entered.
3. To re-record the greeting message, press the key combination 7 and #. Dictate your new greeting after the signal tone.
4. Complete the recording with the keys 7 and #. The new greeting will now be repeated.
5. Finish the call by hanging up.

Switching on remotely

Imagine that you have left your office or your house and have forgotten to switch on your answering system. Using the remote access facility, you can switch on the answering system from another telephone.

1. Call your number and let it ring until your call is answered by your answering system (ca. 10 times).
2. After the signal tone, enter your personal authorisation code. Two tones confirm that the right code has been entered.
3. Press the keys 9 and # and your answering system will be switched on.
4. Now hang up the call or make use of further remote access functions.

Remote access with insufficient memory capacity

You can control your answering system at any time using the remote access facility. If, however, there is no memory left for new messages, the answering system will no longer accept calls. In this case, please proceed as follows:

- 1 Call your number.
2. Let it ring 10 times and your answering system will respond with three tones.
3. Now enter your authorisation code. You will hear two tones in confirmation, you now have the possibility of freeing more memory space by deleting messages. To do this, first listen to the messages and then delete individual messages or all messages. See also Item **Remote access facilities**.

Warranty Terms and Conditions (Australia)

Oricom makes no other warranties or conditions, express or implied, including as to acceptable quality and fitness for a particular purpose, except as stated in this Warranty. Any implied warranties that may be imposed by law are limited in duration to the Warranty Period. Oricom warrants that the product is free from defects in materials or workmanship during the Warranty Period. This Warranty does not extend to any product from which the serial number has been removed or was purchased outside of Australia.

This warranty in no way affects your statutory warranty rights under the Competition and Consumer Act 2010 or any other similar legislation.

The Warranty Period will be 1 year from the date of purchase of the product evidenced by your dated sales receipt. You are required to provide proof of purchase as a condition of receiving warranty services. You are entitled to a replacement product or repair of the product according to the terms and conditions of this document if your product is found to be faulty within the Warranty Period. This Warranty extends to the original purchaser only and is not transferable. Batteries or Battery Packs (if supplied) with this product are covered under this warranty for a period of 90 days.

Products distributed by Oricom are manufactured using new materials or new and used materials equivalent to new in performance and reliability. Spare parts may be new or equivalent to new. Spare parts are warranted to be free from defects in material or workmanship for thirty (30) days or for the remainder of the Warranty Period of the Oricom branded product in which they are installed, whichever is longer. During the Warranty Period, Oricom will where possible repair and if not replace the faulty product or part thereof. All component parts removed under this Warranty become the property of Oricom. In the unlikely event that your Oricom product has a recurring failure, Oricom may, subject to the Competition and Consumer Act 2010, at its discretion, elect to provide you with a replacement product of its choosing that is at least equivalent to your product in performance. Oricom does not warrant that the operation of the product will be uninterrupted or error free.

Oricom is not responsible for damage that occurs as a result of your failure to follow the instructions that came with the product. These terms and conditions together with any specific terms and conditions contained in the user guide to the product purchased constitute the complete and exclusive agreement between you and Oricom regarding the product. No change to the conditions of this Warranty is valid unless it is made in writing and signed by an authorised representative of Oricom.

Oricom will not be in breach of a warranty expressly set out in this User Guide or under the Competition and Consumer Act 2010 and excludes any liability for damages or any other remedy arising under any other legislation or the common law if the damage occurs as a result of:

- 1 failure by you to adhere to the warnings and follow the instructions set out in this user guide for the proper installation and use of the product;
- 2 negligence on your part or misuse by you of the product;
- 3 an uncontrollable external cause which results in the product not functioning including but not limited to power failure, lightning or over voltage; and
- 4 modification to the product or services carried out on the production by anyone other than Oricom or Oricom's authorised service provider.

Oricom will not be liable for any damages caused by the product or the failure of the product to perform, including any lost profits or savings or special, incidental or consequential damages. Oricom is not liable for any claim made by a third party or made by you on behalf of a third party. This limitation of liability applies whether damages are sought, or a claim made, under this Warranty or as a tort claim (including negligence and strict product liability), a contract claim or any other claim. However, this limitation of liability will not apply to claims for personal injury. Nothing in this Warranty excludes, restricts or modifies any condition, warranty, right or remedy which pursuant to the Competition and Consumer Act 2010 applies to this Warranty and which may not be so excluded, restricted or modified. For warranties that cannot be excluded, restricted or modified, Oricom limits the remedies available to those specified in the relevant legislation.

Customer Support

If you have any problems setting up or using this product you will find use-full tips and information in the Troubleshooting section of this user guide as well as “Frequently Asked Questions” on our website www.oricom.com.au.

If you have further questions about using the product after reviewing the resources above or would like to purchase replacement parts or accessories please call our Customer Support Team. Our dedicated local support team are more likely to be able to help you than the retailer where you made your purchase.

Please retain your purchase receipt and attach to the back page of this user guide as you will need to produce this if warranty service is required.

Take a few moments to register your product online: www.oricom.com.au

Australia

Oricom International Pty Ltd
Locked Bag 658
South Windsor, NSW 2756
Australia
Email: support@oricom.com.au
Phone: 1800 81 81 81
(Monday to Friday 8am to 6pm AEST)
Web: www.oricom.com.au
Fax: (02) 4574 8898

New Zealand

Email: support@oricom.co.nz
Phone: 0800 674 266
(Monday to Friday 8am to 6pm AEST)
Web: www.oricom.co.nz



Free Manuals Download Website

<http://myh66.com>

<http://usermanuals.us>

<http://www.somanuals.com>

<http://www.4manuals.cc>

<http://www.manual-lib.com>

<http://www.404manual.com>

<http://www.luxmanual.com>

<http://aubethermostatmanual.com>

Golf course search by state

<http://golfingnear.com>

Email search by domain

<http://emailbydomain.com>

Auto manuals search

<http://auto.somanuals.com>

TV manuals search

<http://tv.somanuals.com>