



FW-X240
AUTO TRANSFORMER
Installation Manual



FW-X240 Auto Transformer

About OutBack Power Systems

OutBack Power Systems is a leader in advanced energy conversion technology. Our products include true sine wave inverter/chargers, maximum power point charge controllers, system communication components, as well as breaker panels, breakers, accessories, and assembled systems.

Notice of Copyright

FW-X240 Auto Transformer Installation Manual © 2007 All rights reserved.

Disclaimer

UNLESS SPECIFICALLY AGREED TO IN WRITING, OUTBACK POWER SYSTEMS:

- (a) MAKES NO WARRANTY AS TO THE ACCURACY, SUFFICIENCY OR SUITABILITY OF ANY TECHNICAL OR OTHER INFORMATION PROVIDED IN ITS MANUALS OR OTHER DOCUMENTATION.
- (b) ASSUMES NO RESPONSIBILITY OR LIABILITY FOR LOSS OR DAMAGE, WHETHER DIRECT, INDIRECT, CONSEQUENTIAL OR INCIDENTAL, WHICH MIGHT ARISE OUT OF THE USE OF SUCH INFORMATION. THE USE OF ANY SUCH INFORMATION WILL BE ENTIRELY AT THE USER'S RISK.

Date and Revision - July, 2008

Contact Information:

OutBack Power Systems
19009 62nd Ave. NE
Arlington, WA 98223

Phone: 360.435.6030

Fax: 360.435.6019

www.outbackpower.com

Welcome to the OutBack Power Systems FW-X240 Auto Transformer

The FW-X240 Auto Transformer can be used for step-up, step-down, generator and split phase output balancing or with series-stacked FX or VFX Series Inverter/Chargers for inverter balancing.

OutBack Power Systems does everything possible to assure the components you purchase will function properly and safely when installed as instructed according to local and national electrical codes (NEC). Please read all of the following instructions and the instructions that come with any other OutBack components that make up your power system.

The FW-X240 Auto Transformer Specifications:

- 120 volt/25 amp primary and secondary side
- 120 or 240 VAC 60 Hz systems only
- Allows powering 240 volt items (e.g., a deep well pump) with a single 120 volt AC source
- Step-down feature allows battery charging with both legs of a 240 volt generator through a single 120 volt FX Series Inverter/Charger

Two identical windings:

- Winding one is between leads #1 and #2
- Winding two is between leads #3 and #4
- The start for each winding are on lead #1 and on lead #3

IMPORTANT SAFETY INSTRUCTIONS

SAVE THESE INSTRUCTIONS

Please read all instructions and cautionary markings on the FW-X240 and other system components and their instructional manuals.

To reduce risk of electric shock:

- Disconnect all DC and AC power sources before attempting any maintenance or repair.
- The input side of the AC and DC breakers may be live even though the breakers are off.
- Be sure to test all terminals with a voltmeter before touching or using any tools.
- Always use caution when using metal tools to prevent contact with live parts or terminals.
- All installations must be in compliance with all local and national electrical codes and standards.

Grounding Instructions

- The FW-X240's metal mounting bracket must be connected to a permanently grounded system. System grounding as required by the National Electric Code, ANSI /NFPA 70-1996, is the responsibility of the system installer.
- The FW-X240 hardware kit includes grounding washers to penetrate a powder-coated finish, assuring a proper ground connection to any FLEXware enclosure or mounting plate.
- An installation might call for an optional grounding wire between the FW-X240 and the FLEXware enclosure or mounting plate to which it's attached depending on local code requirements or the nature of the installation itself.

Connections

- No additional terminals or lugs are required for hook-up of the AC wiring.
- AC wiring must be no less than 10 AWG gauge copper wire, rated for 75 degrees C or higher and must be sized appropriately to the circuit breaker.

Hardware Kit

The FW-X240 comes with four M6 X 20 mm screws, four flat washers, and four grounding washers for mounting to a FLEXware Mounting Plate from inside a FLEXware AC enclosure.

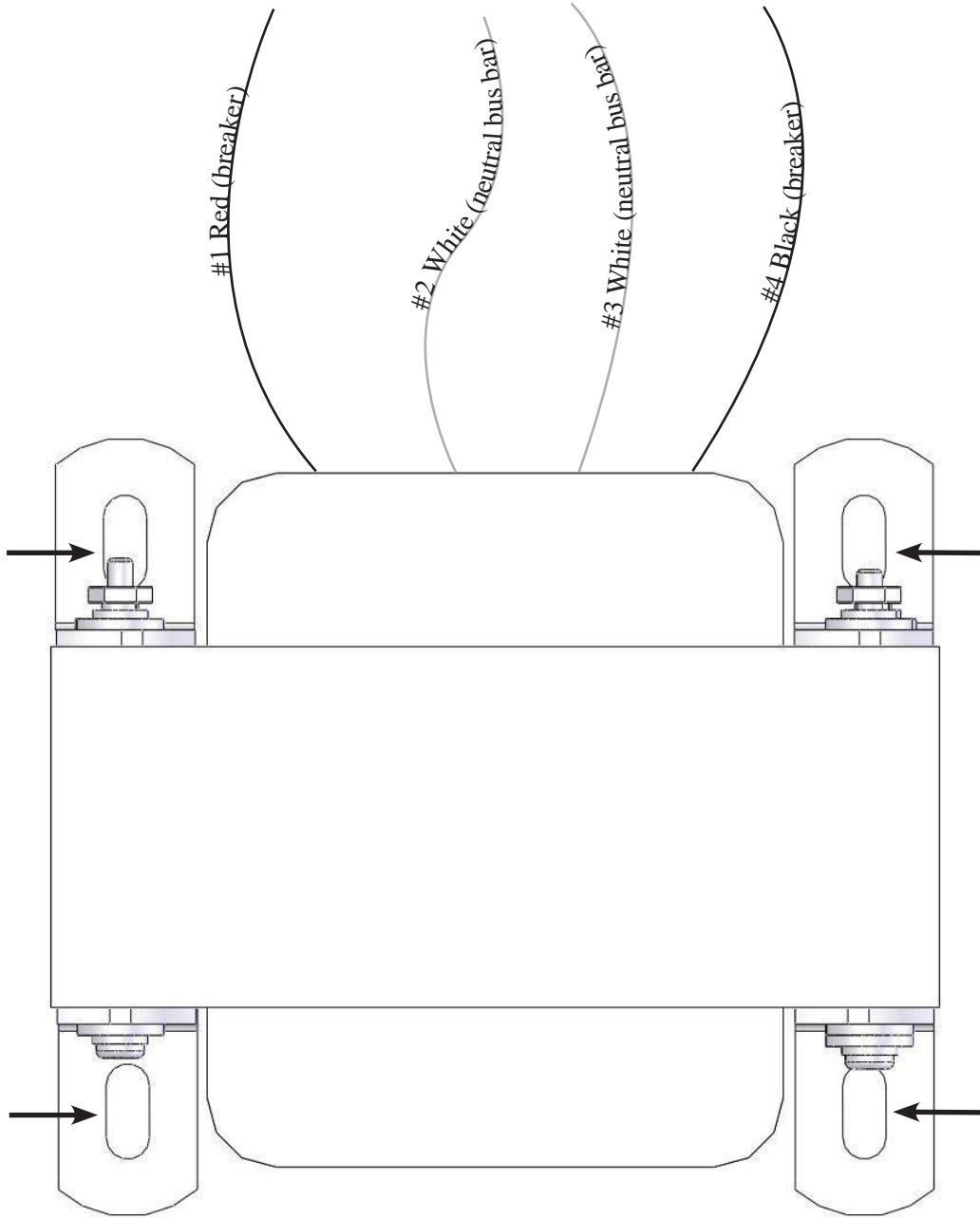

Figure 1: FW-X240 Auto Transformer, top view

→ Mounting Slots ←

The FW-X240 is installed inside a FLEXware enclosure which is designed for attachment to a FLEXware Mounting Plate.

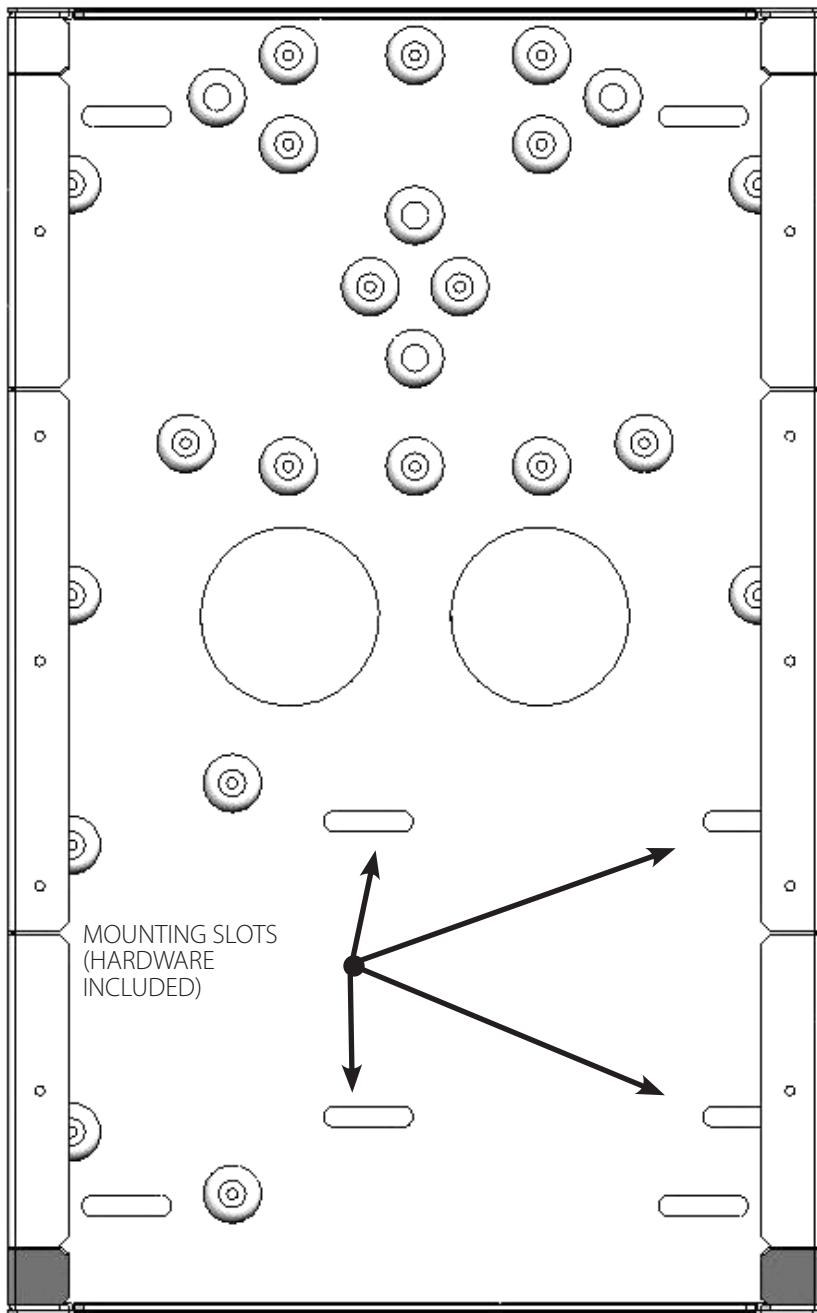
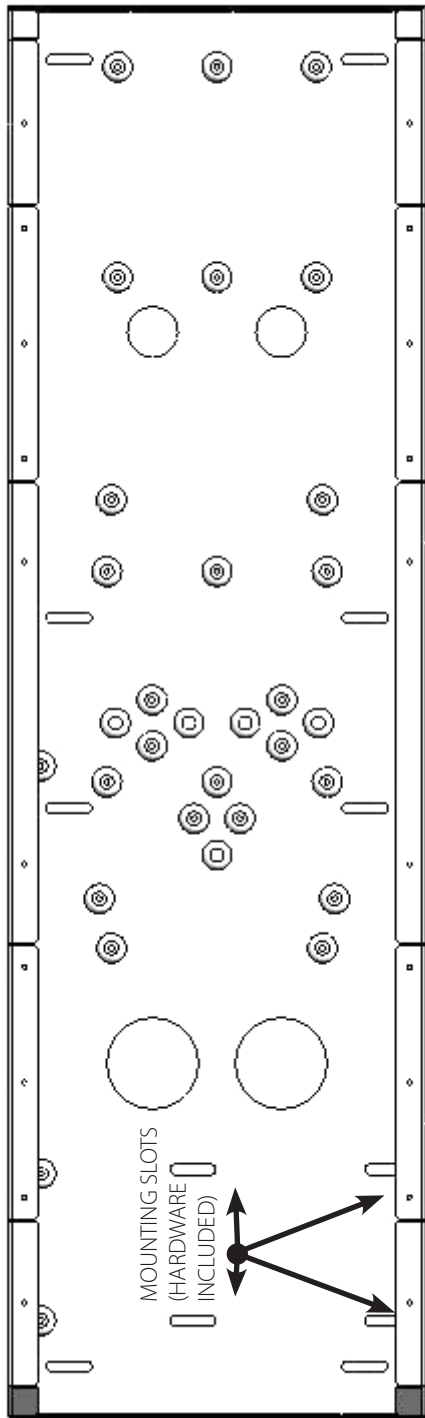

Figure 2: FW500 AC Chassis

Note: The FW-X240 should be installed inside the FW500 after the FW500 is secured to the FLEXware Mounting Plate.



Notes:

- The FW-X240 should be installed inside the FW1000 after the FW1000 is secured to the FLEXware Mounting Plate.
- The FW-X240 can be fastened to other surfaces providing the surface and fasteners used can safely sustain a weight in excess of 25 lbs.

Figure 3 FW1000 AC Chassis

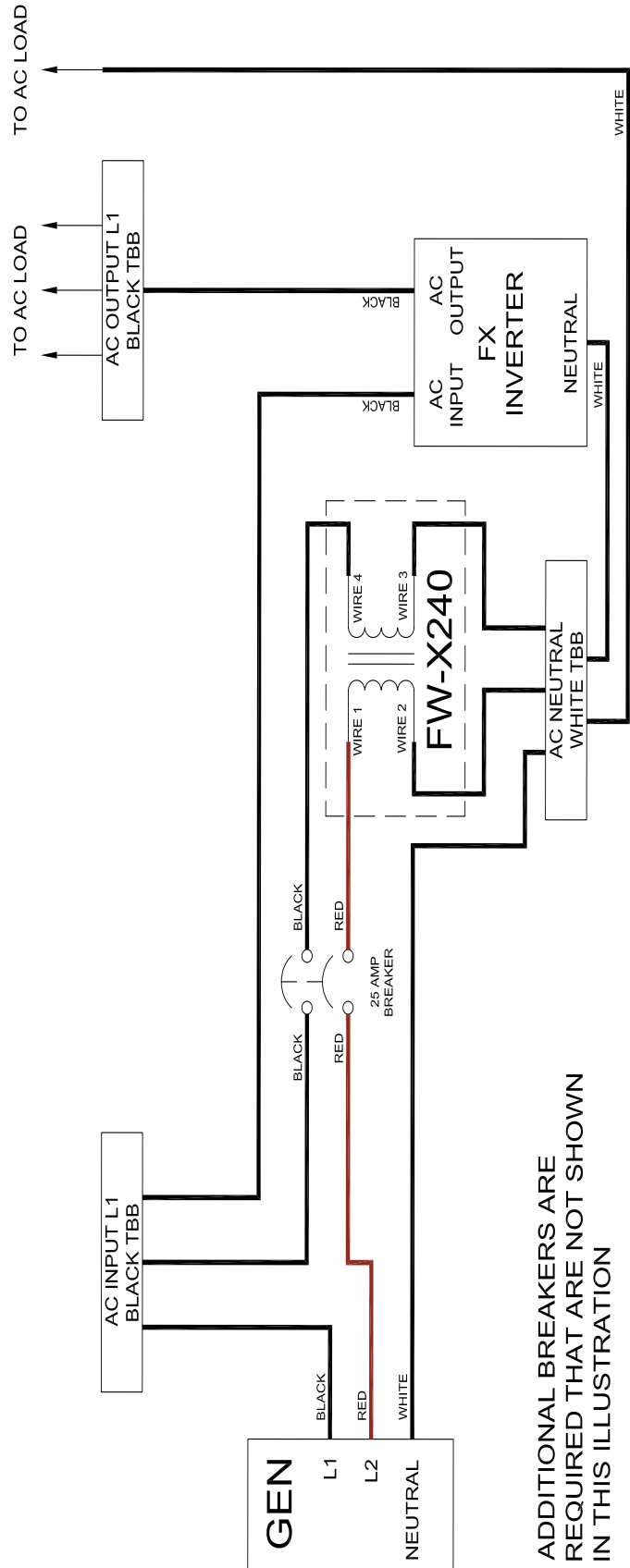

ADDITIONAL BREAKERS ARE
REQUIRED THAT ARE NOT SHOWN
IN THIS ILLUSTRATION

Figure 4: Step-Down Wiring
Diagram

- L1: Black
- L2: Red
- Neutral: White
- TBB: Terminal Bus Bar

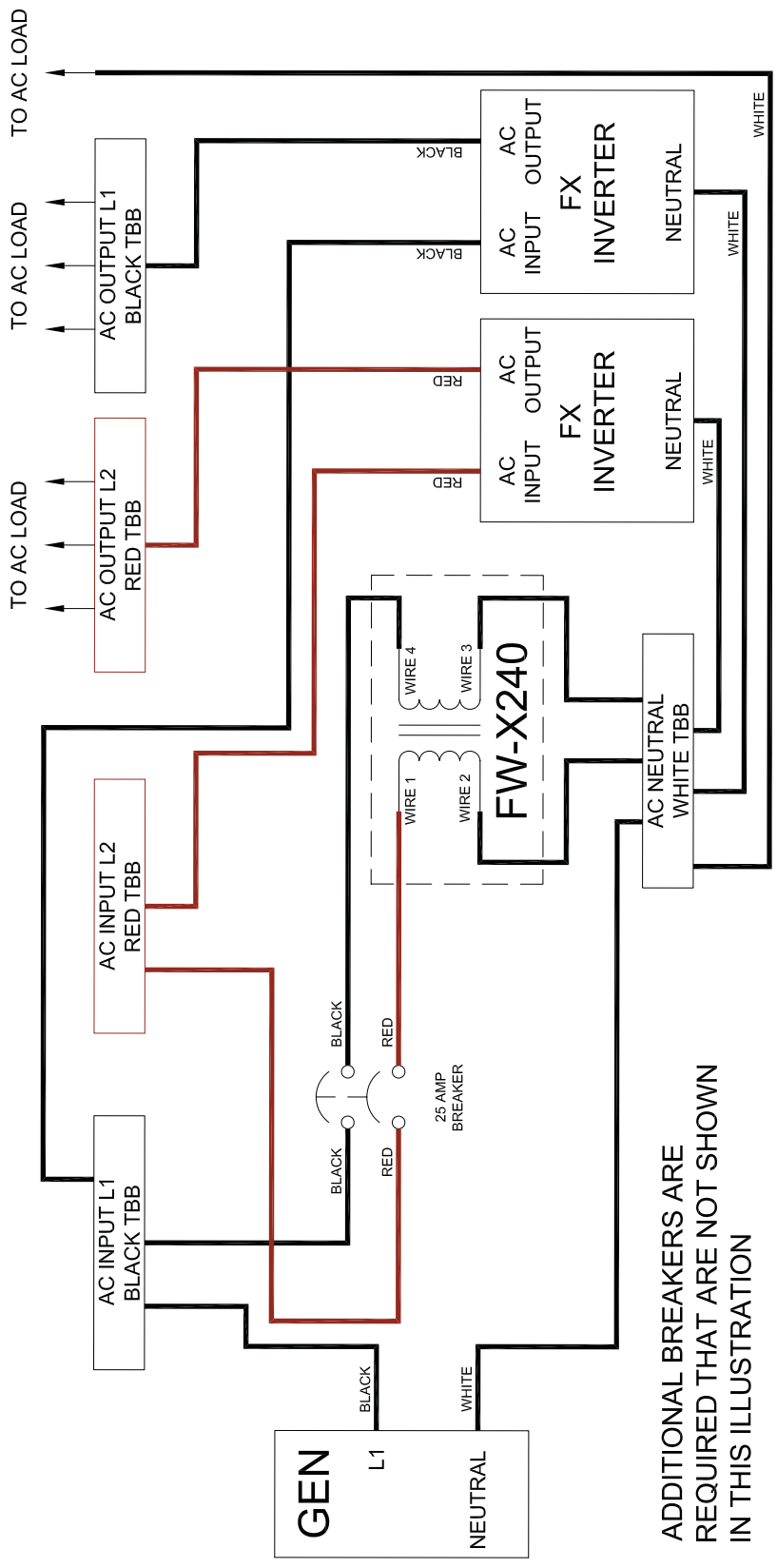

ADDITIONAL BREAKERS ARE
REQUIRED THAT ARE NOT SHOWN
IN THIS ILLUSTRATION

Figure 5: Generator Step-Up Wiring Diagram

- L1: Black
- L2: Red
- Neutral: White
- TBB: Terminal Bus Bar

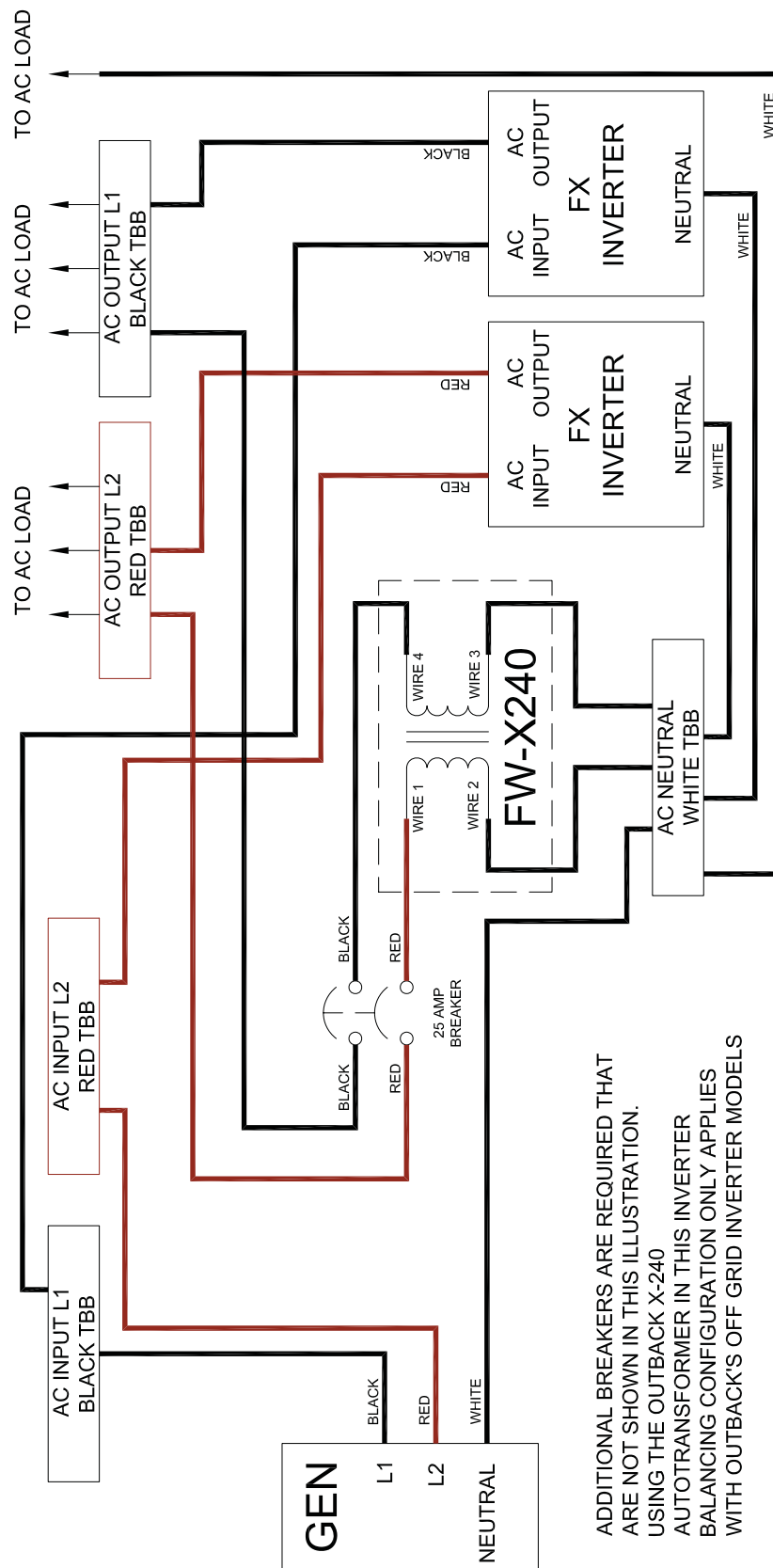

Figure 6: OutBack Stacking Wiring Diagram

- L1: Black
- L2: Red
- Neutral: White
- TBB: Terminal Bus Bar

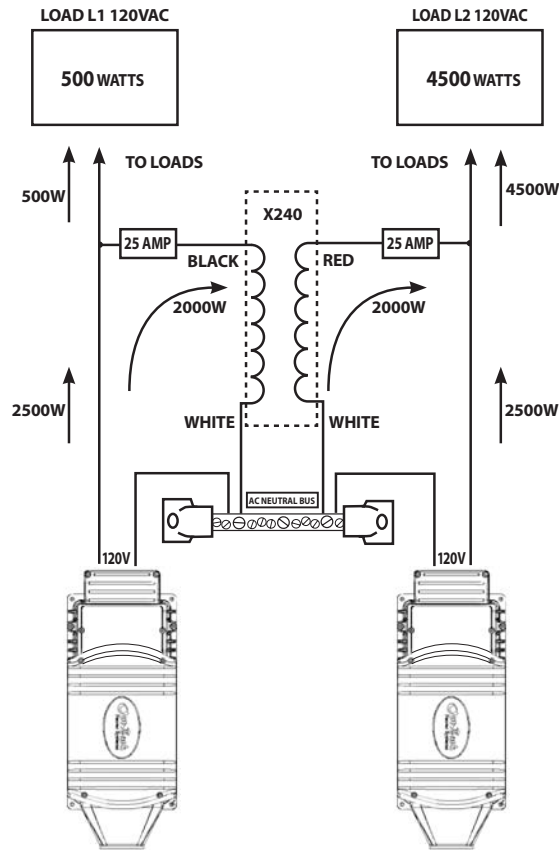

Figure 7: FW-X240 Installation Balancing Two FX Series Inverter/Chargers (OutBack Stacking)*

- * Figure 9 shows current flowing from the L1 FX through the FW-X240 to run in parallel with the L2 FX output. The L1 inverter is producing almost half of the power required to power the load on L2 and at the same time is supplying power to its own L1 load.
- When both FXs are awake and producing power, a 240 Volt load will be powered by both inverters equally.
- If there is less than 1000 watts on L1, then the L2 FX will go to sleep. The FW-X240 is still active and producing 240VAC.
- A small 240VAC load would be powered from the L1 inverter and the FW-X240.
- A large load turning on will wake up the L2 FX. The L2 inverter will go back to sleep as soon as the large load on L2 goes away.

Note: Systems with more than four FXs might require two FW-X240s in parallel and require 35 amp breakers as well.



FLEXware™ Product Registration

Please take a moment to register and provide us with some important information and return it to:
Outback Power Systems Inc.
19009 62nd Ave. NE
Arlington, WA 98223

NOTE: Please complete one form for all installed FLEXware product.

FLEXware Product Registration					
System Owner					
Name: _____	Address: _____				
City, State, Zip Code: _____	Country: _____				
Telephone Number: _____	E-mail: _____				
Installer					
Company: _____	Contractor Number: _____				
Installer Address: _____	Installer City, State, Zip: _____				
Installer E-mail: _____					
System					
System Install/Commission Date: _____					
Sold by: _____	Purchase Date: _____				
Please circle type of application:					
Off-Grid	Grid-Interactive	AC Coupled	Backup	Mobile	
Please circle installed components:					
FLEXware Enclosures and Mounting Components		IOB Kits			
FLEXware 250	FLEXware MP	FW-IOB-S-120VAC	FW-IOB-T-120/208VAC		
FLEXware 500 AC	FLEXware PV 8	FW-IOB-S-230VAC	FW-IOB-T-230/400VAC		
FLEXware 500 DC	FLEXware PV 12	FW-IOB-D-120/240VAC	FW-IOB-Q-120/240VAC		
FLEXware 1000 AC		FW-IOB-D-120VC	FW-IOB-Q-230VAC		
FLEXware 1000 DC		FW-IOB-D-230VAC			
The system is equipped with (circle one):					
FW-X240	PSX-240	PSX-240-Relay			
Please circle the three most important factors affecting your purchase decision:					
• Price	• Product Reputation	• Product Features	• Reputation of OutBack Power Systems	• Value	
I am interested in receiving information concerning OutBack Power Systems products and events (circle one):					
Yes	No				



Corporate Office
19009 62nd Avenue NE
Arlington, WA USA
(+1) 360-435-6030

www.outbackpower.com

European Sales Office
C/ Castelló, 17
08830 - Sant Boi de Llobregat
BARCELONA, España
+34.93.654.9568

900-0076-01-00 REV C

Free Manuals Download Website

<http://myh66.com>

<http://usermanuals.us>

<http://www.somanuals.com>

<http://www.4manuals.cc>

<http://www.manual-lib.com>

<http://www.404manual.com>

<http://www.luxmanual.com>

<http://aubethermostatmanual.com>

Golf course search by state

<http://golfingnear.com>

Email search by domain

<http://emailbydomain.com>

Auto manuals search

<http://auto.somanuals.com>

TV manuals search

<http://tv.somanuals.com>